

Alaris® GP Guardrails® Volumetric Pump

Directions For Use
EN

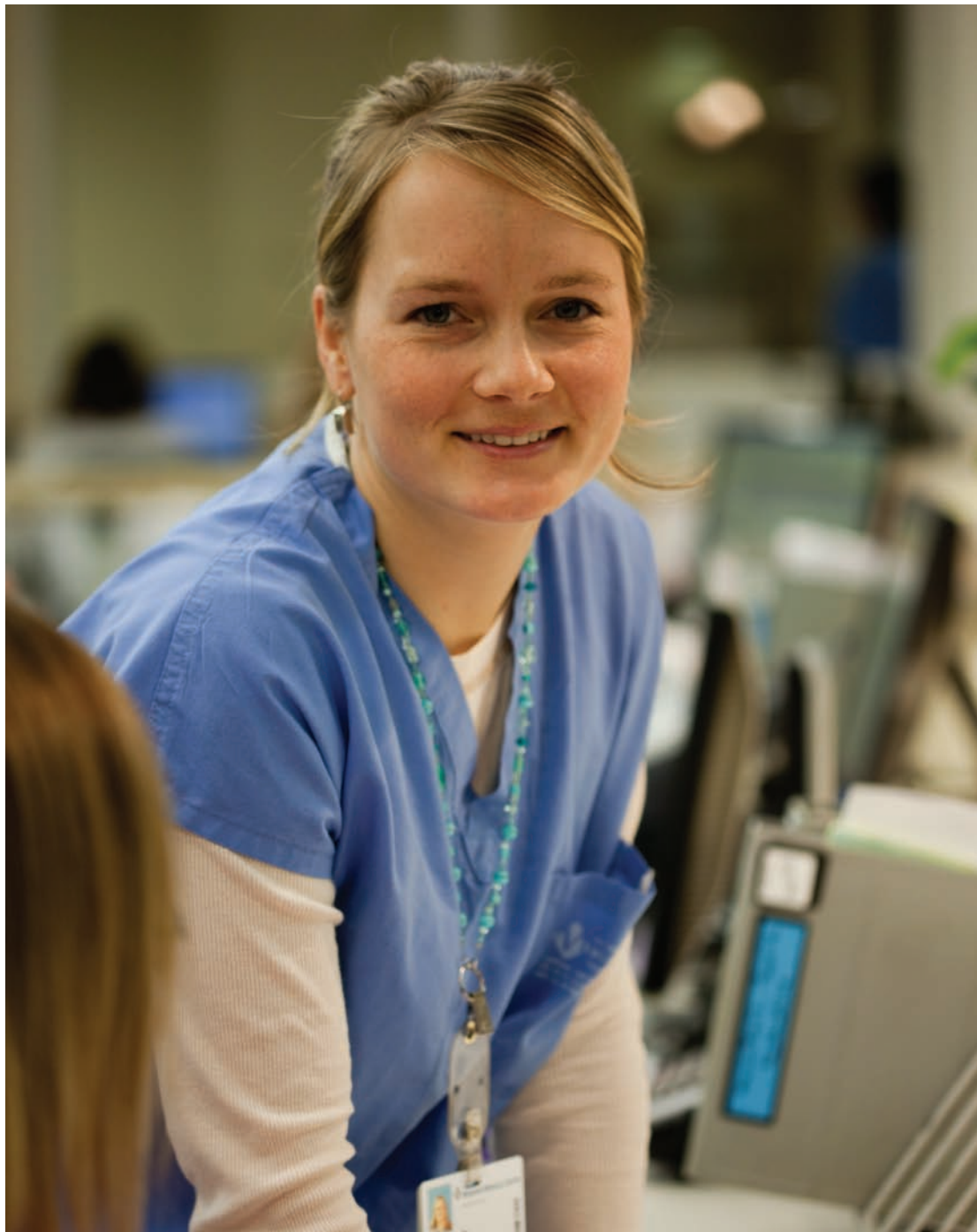

CE
0086

 CareFusion

	<i>Page</i>
• Introduction	2
• About this Manual	2
• Creating a Data Set	3
• Features of the Alaris® GP Guardrails® Volumetric Pump	4
• Controls and Indicators	5
• Symbol Definitions	6
• Main Display Features	7
• Operating Precautions	8
• Getting Started	10
• The Alaris® Safety Clamp	12
• Loading an Infusion Set	13
• Starting the Infusion	14
• Basic Features	15
• Secondary (Piggyback) Infusions	21
• Service Configuration Mode	22
• Pump Configuration available via the Guardrails® Editor Software	23
• Drug List available via the Guardrails® Editor Software	24
• Alarms	25
• Warnings	26
• Prompts and Advisories	27
• Flow Sensor Operation (Optional)	28
• Infusion Sets	29
• Associated Products	33
• Maintenance	34
• Cleaning and Storage	35
• Disposal	35
• Specifications	36
• IrDA, RS232 and Nursecall Specification	37
• Infusion Specifications	38
• Trumpet & Flow Rate Curves	39
• Products and Spare Parts	41
• Service Contacts	42
• Document History	42

Introduction

The Alaris® GP Guardrails® Volumetric Pump (hereinafter referred to as 'Pump') is a small lightweight volumetric infusion pump that provides accurate and reliable infusions over a range of rates.

The Guardrails® Editor software* is a medical device accessory, which allows the hospital to develop a best-practice data set of IV medication dosing guidelines for patient-specific care areas referred to as profiles. Each profile contains a specific library of drugs, as well as an appropriate pump configuration. A profile also contains Guardrails® hard limits that cannot be overridden during infusion programming. Additionally Guardrails® soft limits are available and can be overridden, based on clinical requirements.

The hospital defined data set is developed and approved through pharmacy and clinical input, and then transferred into the Alaris® GP Guardrails® Volumetric Pump by qualified technical personnel.

The Alaris® GP Guardrails® Volumetric Pump with a data set loaded, provides automatic alerts when a dosing limit, bolus limit, concentration limit, or weight limit has been exceeded. These safety alerts are provided without the need for the pump to be connected to a PC or network.

INTENDED USE:

The pump is designed to meet the infusion requirements within the operating environment specified in this Directions For Use (DFU) including general wards, critical and intensive care, operating rooms and accident and emergency rooms.

The clinician is responsible for evaluating whether the pump is appropriate for use in a specified patient care area.

This pump is suitable for use by appropriately trained clinicians or nurses. This pump can be used for Intravenous modes, supporting fluid therapy, drug therapy, blood transfusions and parenteral nutrition.

* Only some parts of the Guardrails® Editor software are classified as medical device accessories.

About this Manual

The user must be thoroughly familiar with the pump described in this manual prior to use.

The Alaris® GP Guardrails® Volumetric Pump has minor functionality differences to the Alaris® GH/CC Guardrails® Syringe Pumps.

All illustrations used in this manual show typical settings and values which may be used in setting up the functions of the pump.

These settings and values are for illustrative use only. The complete range of settings and values are detailed in the specifications section.

Creating a Data Set

To create a data set for the Alaris® GP Guardrails® Volumetric Pump, first the hospital will need to develop, review, approve, upload according to the following process. Refer to the Guardrails® Editor help file for further details and operating precautions.

1. Create care area data set (Using Guardrails® Editor)

<i>Profile</i>	<p>A unique set of configurations and best-practice guidelines for a specific population, patient type or care area.</p> <p>Each profile consists of: Pump Configuration / Drug List</p> <p>Up to 30 profiles can be defined for each Data Set.</p>
<i>Pump Configuration</i>	<p>Pump configuration settings and units for dosing only.</p>
<i>Drug List</i>	<p>Drug names and concentrations for a data set with default value and maximum limits.</p> <p>Up to 100 unique drug names/drug protocol set-ups.</p>

2. Review, approve and export data set (Using Guardrails® Editor)

<i>Review and Approve</i>	<p>Entire data set report to be printed, reviewed and signed as proof of approval by an authorised person, according to hospital protocol. Signed printout to be kept safe by hospital. Data set status to be set to Approved (Password is required).</p>
<i>Export</i>	<p>Export data set for use by the Data Set Transfer Tool, or to back up a data set, or to move the data set to another PC.</p>

3. Upload data set to Alaris® GP Guardrails® Volumetric Pump (Using Data Set Transfer Tool)

4. Verify that the correct data set is loaded into the pump and accept it.

5. Switch the pump off. The pump is now ready to use.

6. Switch the pump on and verify that the software version screen displays the correct data set version.



Data set transfers should only be performed by qualified technical personnel.







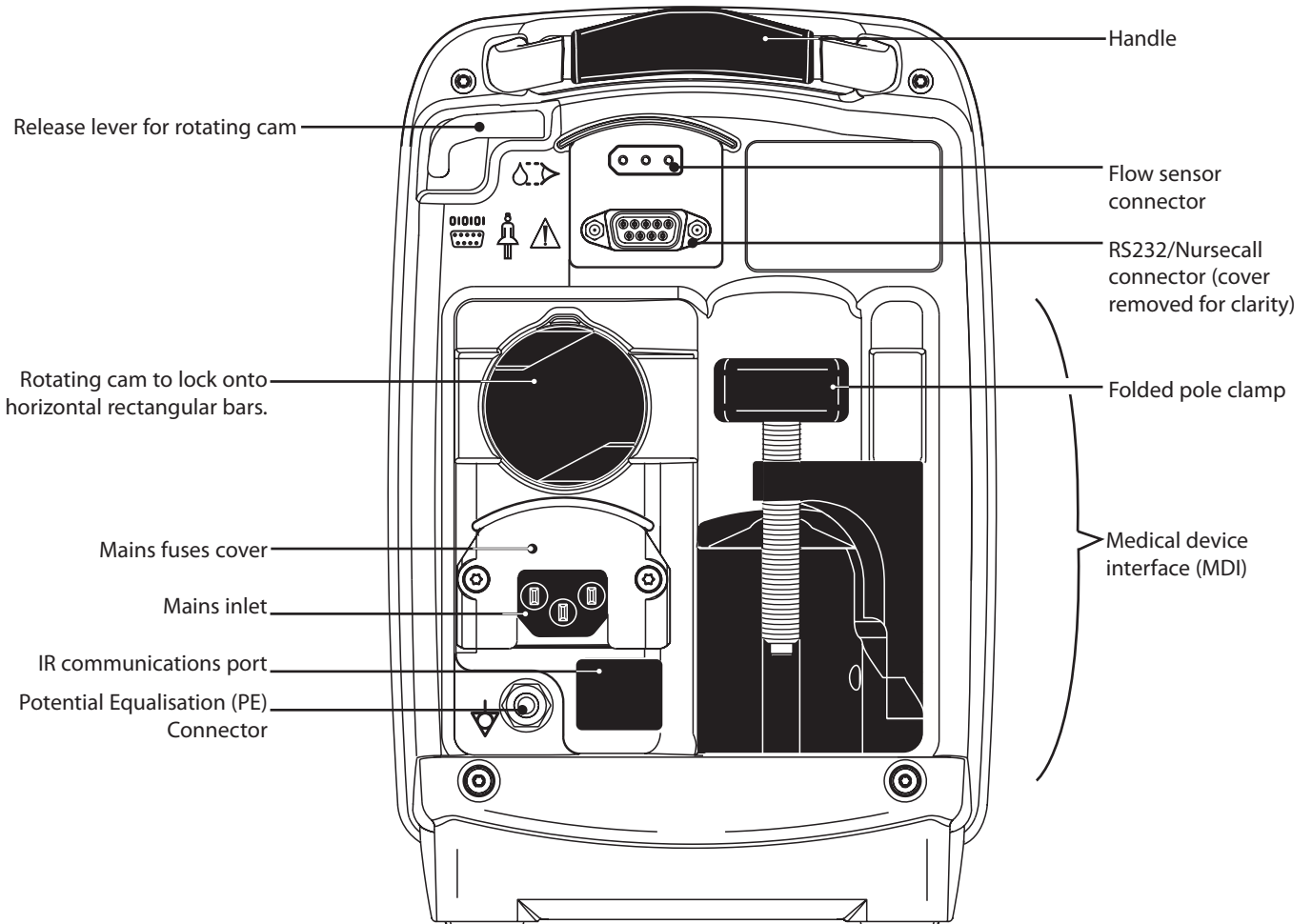
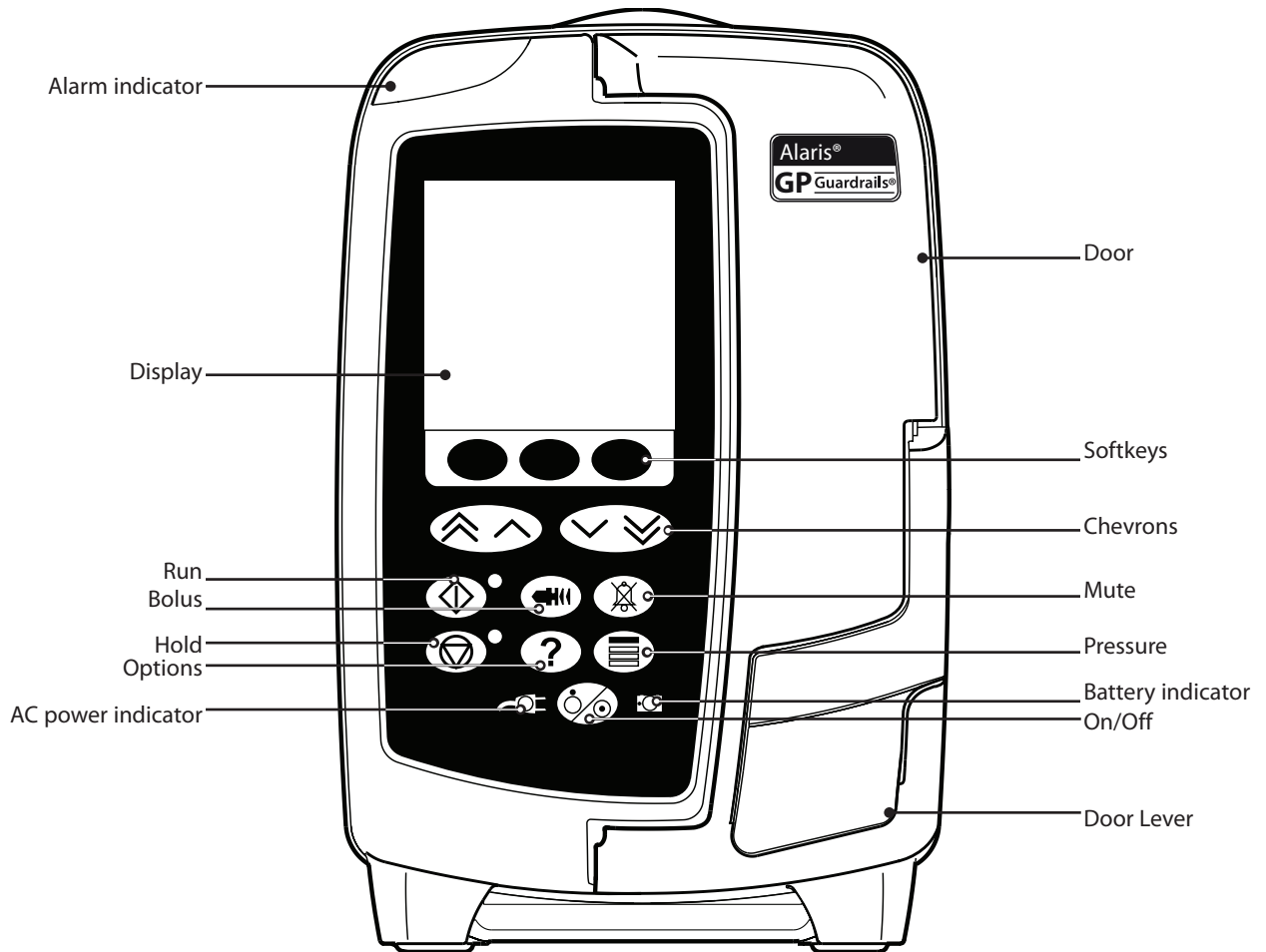

The pump serial number and the hospital name are stored in the event log.

Drug parameters have to be in accordance with local regulation and prescribed information.



Features of the Alaris® GP Guardrails® Volumetric Pump















Controls:

Symbol	Description
	ON/OFF button - Press once to switch the pump ON. Press and hold down for approximately 3 seconds to switch the pump OFF.
	RUN button - Press to start the infusion. The green LED will flash during infusion.
	HOLD button - Press to put the infusion on hold. The amber LED will be lit while on hold.
	MUTE button - Press to silence alarm for (approximately) 2 minutes. The alarm will resound after this time.
	BOLUS button - Press to access BOLUS softkey. Press and hold down softkey to operate. BOLUS - fluid or drug delivered at an accelerated rate. <ul style="list-style-type: none"> • Pump is infusing • Infusion set is connected to patient. • Volume infused (VI) is added to the total volume infused displayed.
	OPTION button - Press to access optional features.
	PRESSURE button - Use this button to display the pumping pressure and adjust the alarm limit.
	CHEVRON keys - Double or single for faster / slower increase / decrease of values shown on display.
	BLANK SOFTKEYS - Use in conjunction with the prompts shown on the display.

Indicators:

Symbol	Description
	AC POWER indicator - When illuminated the pump is connected to an AC power supply and the battery is being charged.
	BATTERY indicator - When illuminated the pump is running on the internal battery. When flashing the battery power is low with less than 30 minutes of use remaining.

Labelling Symbols:

Symbol	Description
	Attention (Consult accompanying document)
	Potential Equalisation (PE) Connector
	RS232/Nursecall Connector.
	Defibrillation-proof type CF applied part. (Degree of protection against electrical shock)
IPX3	Protected against spraying water
	Alternating Current
	Device complies with the requirements of Council Directive 93/42/EEC as amended by 2007/47/EC.
	Date of Manufacture
	Manufacturer
	Connector for Flow Sensor
	Important Information
	Not for Municipal Waste
	Fuse rating
	Authorised representative in the European Community

Main Display - If VTBI has not been set (flow sensor must be used):

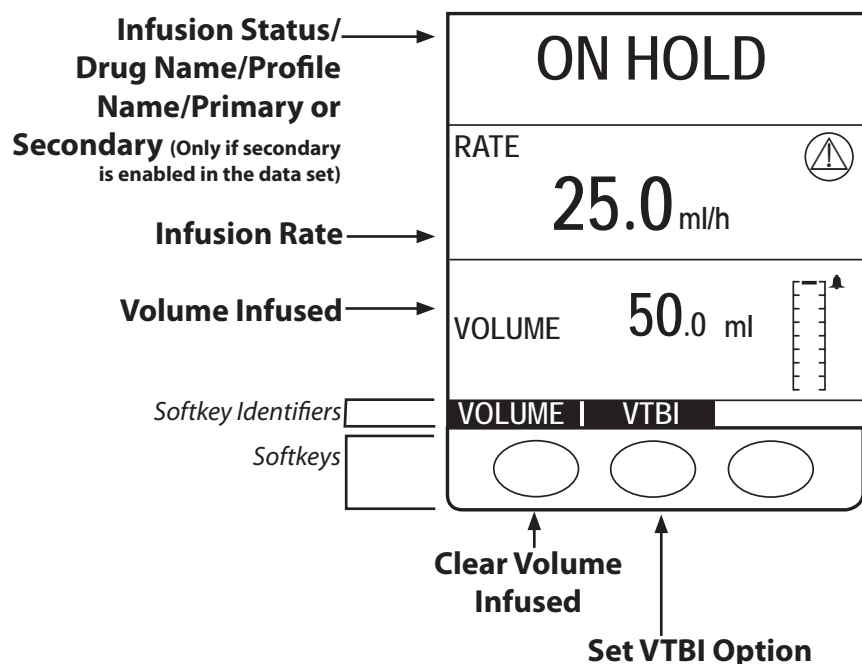

If the rate has not been set and is showing at 0.0ml/h, then message a) will be displayed.



If programmed rate is between 0.0ml/h and 0.1ml/h exclusive in drug protocol message b) will be shown.

Main Display - If VTBI is set:

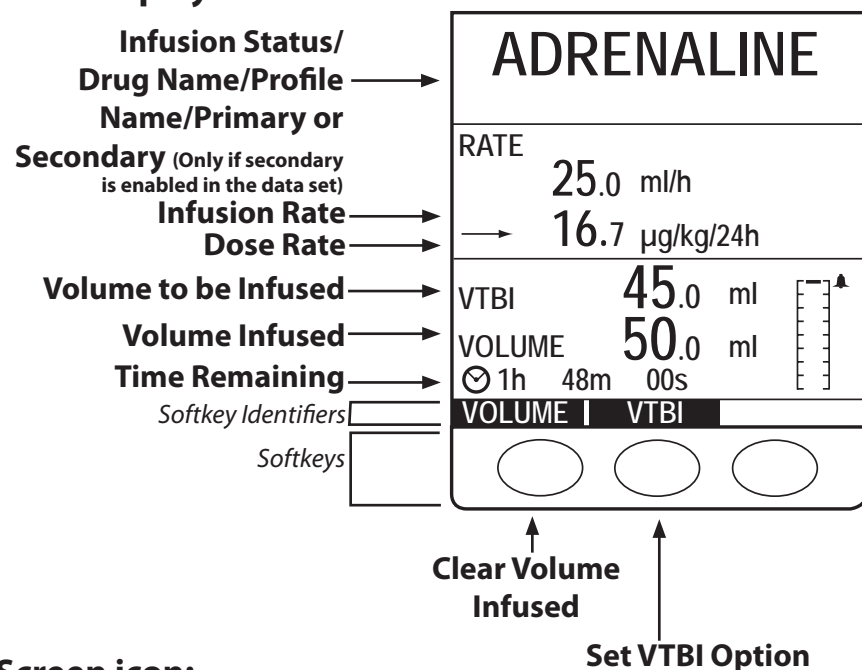

If programmed rate is greater than the **Infusion Rate Max** in drug protocol, message c) will be shown.

Screen icon:

	TIME REMAINING DISPLAY icon - Indicates time remaining before VTBI will be completed. If the time is greater than 24 hours then 24+ will be displayed.
	PRESSURE INFORMATION icon - Shows the pressure from level 0 being the first bar to level 8. Alarm limits: level 2, 5 or 8.
	Indicates that a Guardrails® safety protocol is not in use. CareFusion recommends the use of Guardrails® safety limits when setting infusions as standard practice.
	Indicates that the value entered is outside of the soft limits. The warning can be overridden. (Indicates Guardrails® safety protocol is in use)
	Indicates that the value entered is outside of the hard limits. The warning can NOT be overridden. This symbol is also used to prompt the user to set the rate. (Indicates Guardrails® safety protocol is in use)

Operating Precautions

Infusion Sets

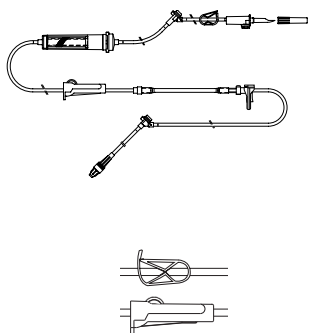

- To ensure correct and accurate operation, only use CareFusion single use infusion sets described in this Directions For Use.
- It is recommended that infusion sets are changed according to the instructions in the 'Changing the Infusion Set' section. Carefully read the Directions For Use supplied with the infusion set prior to use.
- Use of non-specified infusion sets may impair the operation of the pump and the accuracy of the infusion.
- When combining several apparatus and/or instruments with infusion sets and other tubing, for example via a 3-way tap or multiple infusion, the performance of the pump may be affected and should be monitored closely.
- Uncontrolled flow may result if the infusion set is not properly isolated from the patient i.e. closing a tap in the set or activating an in-line clamp / roller clamp.
- The infusion set may be fitted with an in-line clamp, which can be used to occlude tubing in case it is required to stop fluid flow.
- The Alaris® GP Guardrails® Volumetric Pump is a positive pressure pump, which should use infusion sets fitted with Luer lock fittings or equivalent locking connectors.
- To infuse from a burette, close the roller clamp above the burette and open the clamp on the vent on top of the burette.
- Discard infusion set if the packaging is not intact or the protector cap is detached. Ensure sets are not kinked as this may occlude the tubing.

Using Collapsible bags, Glass Bottles & Semi Rigid containers

- It is recommended that the air vent be opened on the Alaris® GP Guardrails® Volumetric Pump set if using glass bottles or semi-rigid containers, to reduce the partial vacuum formed as the fluid is infused from the container. This action will ensure the pump can maintain volumetric accuracy whilst the container empties. The action of opening the air vent for semi-rigid containers should take place after the spiking of the container and priming of the drip chamber.

Steps for the Collapsible bags

Follow steps 1 to 3 as shown for the semi-rigid containers, however **do not** open vent as in step 4, but prime the set as per step 5. Ensure the bag outlet is fully pierced before filling the drip chamber.

Steps for Semi-rigid containers

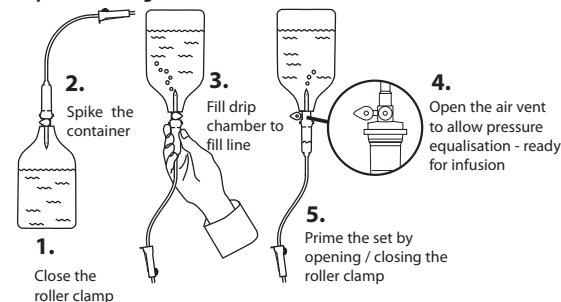

Operating Environment

- When using any infusion pump in conjunction with other pumps or devices requiring vascular access, extra care is advised. Adverse delivery of medication or fluids can be caused by the substantial variation in pressures created within the fluid channels of such pumps. Typical examples of those pumps are used during dialysis, bypass or cardiac assist applications.
- The pump is suitable for use in all establishments, including domestic establishments and those directly connected to the public low voltage power supply network that supplies buildings used for domestic purposes.
- This pump is not intended to be used in the presence of a flammable anaesthetic mixture with air or oxygen or nitrous oxide.

Operating Pressure

- The pumping pressure alarm system is not designed to provide protection against, or detection of extravasation or tissueing, complications which can occur.

Alarm Conditions

- Several alarm conditions detected by this pump will stop the infusion and generate visual and audible alarms. Users must perform regular checks to ensure that the infusion is progressing correctly and no alarms are operating.



Operating Precautions (Continued)



Electromagnetic Compatibility and Interference

- This pump is protected against the effects of external interference, including high energy radio frequency emissions, magnetic fields and electrostatic discharge (for example, as generated by electrosurgical and cauterising equipment, large motors, portable radios, cellular telephones etc.) and is designed to remain safe when unreasonable levels of interference are encountered.
- **Therapeutic Radiation Equipment:** Do not use the pump in the vicinity of any Therapeutic Radiation Equipment. Levels of radiation generated by the radiation therapy equipment such as Linear Accelerator, may severely affect functioning of the pump. Please consult manufacturer's recommendations for safe distance and other precautionary requirements. For further information, please contact your local CareFusion representative.
- **Magnetic Resonance Imaging (MRI):** The pump contains ferromagnetic materials which are susceptible to interference with magnetic field generated by the MRI devices. Therefore, the pump is not considered an MRI compatible pump as such. If use of the pump within an MRI environment is unavoidable, then CareFusion highly recommends securing the pump at a safe distance from the magnetic field outside the identified 'Controlled Access Area' in order to evade any magnetic interference to the pump; or MRI image distortion. This safe distance should be established in accordance with the manufacturers' recommendations regarding electromagnetic interference (EMI). For further information, please refer to the product technical service manual (TSM). Alternatively, contact your local CareFusion representative for further guidance.
- **Accessories:** Do not use any non-recommended accessory with the pump. The pump is tested and compliant with the relevant EMC claims only with the recommended accessories. Use of any accessory, transducer or cable other than those specified by CareFusion may result in increased emissions or decreased pump immunity.
- In some circumstances the pump may be affected by an electrostatic discharge through air at levels close to or above 15kv; or by radio frequency radiation close to or above 10v/m. If the pump is affected by this external interference the pump will remain in a safe mode; the pump will duly stop the infusion and alert the user by generating a combination of visual and audible alarms. Should any encountered alarm condition persist even after user intervention, it is recommended to replace that particular pump and quarantine the pump for the attention of appropriately trained technical personnel.
- This pump is a CISPR 11 Group 1 Class B device and uses RF energy only for its internal function in the normal product offering. Therefore, its RF emissions are very low and are not likely to cause any interference with the nearby electronic equipment. However, this pump emits a certain level of electromagnetic radiation which is within the levels specified by IEC/EN60601-2-24 and IEC/EN60601-1-2. If the pump interacts with other equipment, measures should be taken to minimise the effects, for instance by repositioning or relocation.



Earth Conductor

- The Alaris® GP Guardrails® Volumetric Pump is a Class I device, therefore must be earthed when connected to an AC power supply.
- This pump also has an internal power source.
- When connected to an external power source, a three-wire (Live, Neutral, Earth) supply must be used. If the integrity of the external protective conductor on the AC power cable has been compromised, the pump should be disconnected from the AC power source and operated utilising the internal battery.

Hazards



- An explosion hazard exists if the pump is used in the presence of flammable anaesthetics. Exercise care to locate the pump away from any such hazardous sources.
- **Dangerous Voltage:** An electrical shock hazard exists if the pump's casing is opened or removed. Refer all servicing to qualified service personnel.
- Do not open the RS232/Nurse Call protective covering when not in use. Electrostatic discharge (ESD) precautions are required when connecting RS232/Nurse Call. Touching the pins of the connectors may result in ESD protection failure. It is recommended that all actions must be taken by appropriately trained personnel.
- If this pump is dropped, subjected to excessive moisture, fluid spillage, humidity or high temperature, or otherwise suspected to have been damaged, remove it from service for inspection by a qualified service engineer. When transporting or storing the pump, use original packaging where possible, and adhere to temperature, humidity and pressure ranges stated in the Specifications section and on the outer packaging.
- If this pump behaves abnormally, remove from service and contact a qualified service engineer.
- Care should be taken to ensure power leads and RS232 cables do not present a trip hazard.
- Care should be taken in the placement of power leads and RS232 cables to prevent accidental tugging.

Getting Started



Before operating the pump read this Directions For Use (DFU) manual carefully.

Initial Set Up

1. Check that the pump is complete, undamaged and that the voltage rating specified on the label is compatible with your AC power supply.
2. Items supplied are :
 - **Alaris® GP Guardrails® Volumetric Pump**
 - **Directions For Use (CD)**
 - **AC Power Cable (as requested)**
 - **Protective Packaging**
 - **Guardrails® Editor software and/or Data Set Transfer Tool - per hospital**
3. Connect the pump to the AC power supply for at least 2½ hours to ensure that the internal battery is charged (verify that the  is lit).



The Guardrails® Editor software can be used to create an approved data set that can be uploaded into the pump. However, a default data set is already installed in the pump (See details below).

The pump will automatically operate from its internal battery if the pump is switched on without being connected to the power supply.

Should the pump fail to perform correctly, replace in its original protective packaging, where possible and contact a qualified service engineer for investigation.

Factory Default Data Set

The Alaris® GP Guardrails® Volumetric Pump is supplied with the following factory default data set:

Parameter	Factory Default Setting
AC Fail Warning	Enabled
Alarm Volume	Medium
Alarm Volume Adjustable	Disabled
Occlusion Limit Default	L5
Occlusion Limit Max	L8
Rate Titration	Disabled
Infusion Rate Max	1200ml/h
Rate Lock	Disabled
Bolus Mode	Hands-On Only
Bolus Rate Default	500ml/h
Bolus Rate Max	1200ml/h
Bolus Volume Max	5ml
Weight Default	1kg
Weight Soft Min	1kg
Weight Soft Max	150kg
AIL Limit	100µl
Primary VTBI Max	9999ml
Secondary Infusion	Disabled

Default Units Enabled for Dosing Only:

µg/min
µg/h
mg/h
g/h
U/h
mmol/h
ng/kg/min
µg/kg/min
µg/kg/h
mg/kg/min
mg/kg/h
U/kg/h
mmol/kg/min
mmol/kg/h



Refer to 'Display of Units' section of the DFU for configurable units.

The default data set does not have Guardrails® limits. To set the limits use the Guardrails® Editor software. Care should be taken when specifying the Guardrails® limits.

Getting Started (Continued)

Pole Clamp Installation

A pole clamp is fitted to the rear of the pump and will provide secure fixing to vertical I.V. poles of a diameter between 15 and 40 mm.

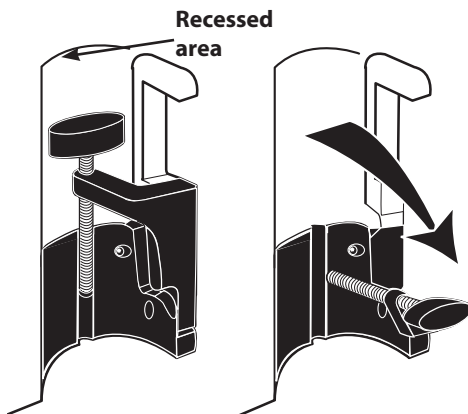

1. Pull the folded pole clamp towards you and unscrew the clamp to leave enough room for the size of the pole.
2. Place pump around pole and tighten screw until the clamp is secured to the pole.



Never mount the pump such that the infusion stand becomes top heavy or unstable.

Ensure pole clamp is folded away and stored within recessed area at the rear of the pump before connecting to a Docking Station/Workstation* or when not in use.

Docking Station/Workstation* or Equipment Rail Installation

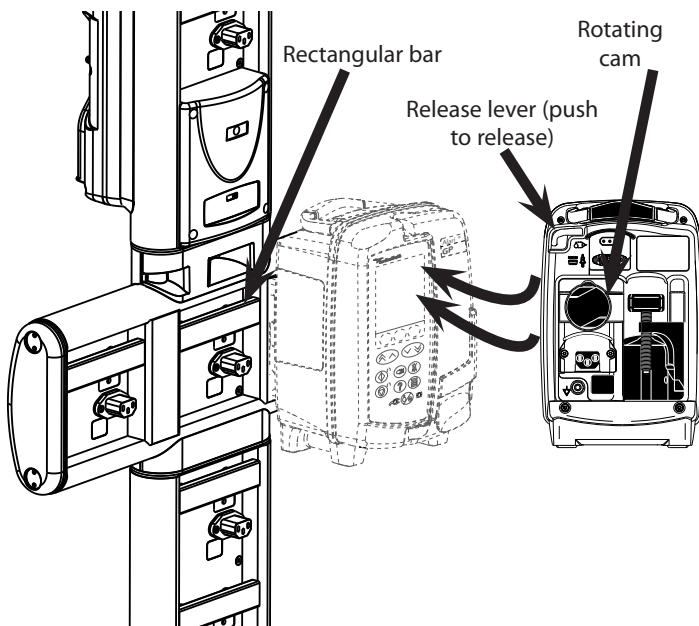

The rotating cam can be fitted to the rectangular bar on the Docking Station/Workstation* or equipment rails measuring 10mm by 25mm.

1. Align the rotating cam on the rear of the pump with the rectangular bar on the Docking Station/Workstation* or the equipment rail.
2. Push the pump firmly onto the rectangular bar or equipment rail.

Ensure that the pump 'clicks' securely into position onto the rail or bar.

3. To release, push the release lever and pull the pump forwards.



It is recommended that infusion bags be located on a hanger directly above the pump with which they are being used. This minimises the potential for confusion of infusion sets when multiple volumetric pumps are used.

*Alaris® DS Docking Station and Alaris® Gateway Workstation.

Pump can only be mounted on the horizontal section of the docking stations listed above.

ALARIS® SAFETY CLAMP:**

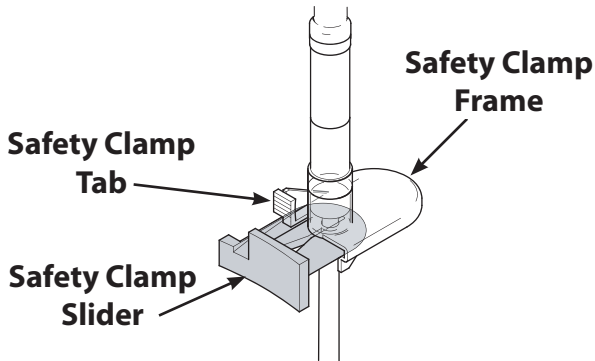

SAFETY CLAMP IN NON OCCLUDED POSITION:

When a new infusion set is removed from packaging the Safety Clamp will be in this position:*

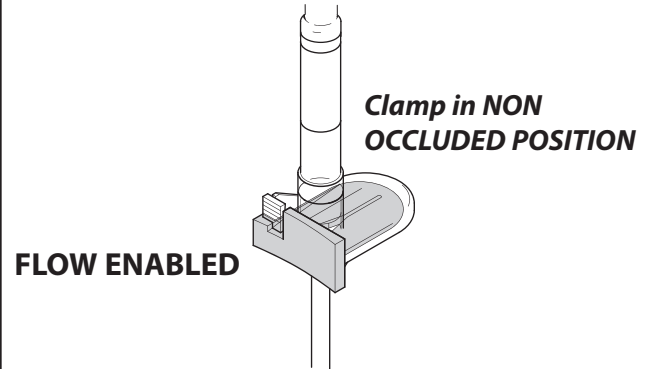

* This is necessary to avoid tube damage during storage and to ensure correct sterilisation and allows immediate priming.

SAFETY CLAMP IN OCCLUDED POSITION:

After infusion set is loaded into the pump, opening the door activates door hooks which will pull the Safety Clamp slider out, as shown:

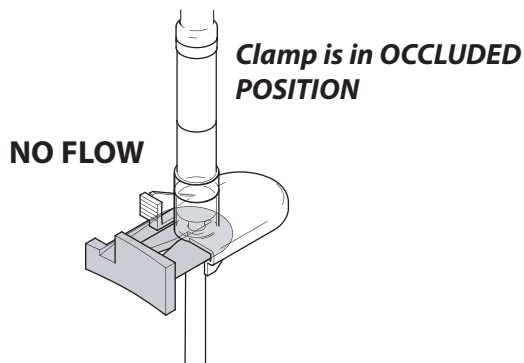

MANUALLY OPERATING THE SAFETY CLAMP

To move the slider into the non occluded position manually, push up Safety Clamp Tab and push Safety Clamp Slider completely into Frame:

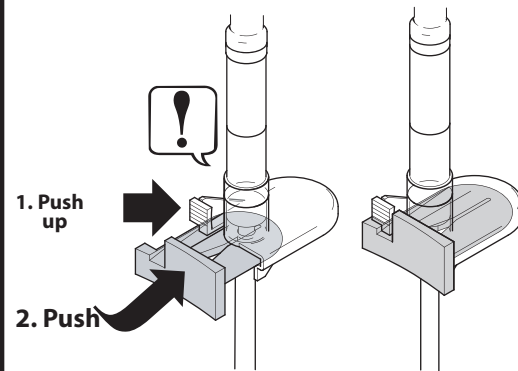

Pushing on the Safety Clamp Slider enables full set flow to the patient. Therefore it is recommended to always close the roller clamp as well.

However, if gravity infusion is required, push up Safety Clamp Tab and push orange Safety Clamp Slider completely into Frame to enable flow. The gravity infusion can be regulated using the roller clamp on the set.

** - Hereinafter referred to as to as 'Safety Clamp'.

Loading an Infusion Set



Ensure the appropriate infusion set for the fluid/drug to be infused has been selected.

Follow the instructions supplied with the individual infusion set.

Only use Alaris® GP Guardrails® Volumetric Pump infusion sets, (Refer to 'Infusion Sets' section of the DFU)

Position the fluid container to avoid spillage onto the pump.

Ensure that the tubing is inserted completely into the top set retainer through to the tubing guide avoiding any slack.

Loading an Infusion Set: Alaris® Safety Clamp in the NON OCCLUDED position - FLOW ENABLED

	<ol style="list-style-type: none"> 1. Remove infusion set from package and close roller clamp.
	<ol style="list-style-type: none"> 2. Insert the bag spike into the fluid container and hang appropriately. At a minimum height of 300 mm above the pump.
	<ol style="list-style-type: none"> 3. Fill the drip chamber to the fill line if shown. (Approximately half full) Refer to operating precaution section 'Using Collapsible bags, Glass Bottles & Semi-Rigid containers'.
	<ol style="list-style-type: none"> 4. Open roller clamp and prime set slowly (to prevent air bubbles) ensuring all air is removed.
	<ol style="list-style-type: none"> 5. Close roller clamp.
	<ol style="list-style-type: none"> 6. Switch the pump on. Open door and load infusion set as follows: <ul style="list-style-type: none"> • Fit blue adaptor of infusion set into blue top set retainer. • Insert orange safety clamp into orange retainer.
	<ol style="list-style-type: none"> 7. Ensure infusion set is fully inserted into tubing guide.
	<ol style="list-style-type: none"> 8. Close door and open roller clamp. Ensure no drops are falling in the drip chamber.
	<ol style="list-style-type: none"> 9. Ensure all air is removed from the set. Connect the infusion set to the patient access device.

Loading an Infusion Set: Alaris® Safety Clamp in the OCCLUDED position - NO FLOW

	<ol style="list-style-type: none"> 1. Follow steps 1 to 4 as above where necessary.
	<ol style="list-style-type: none"> 2. Ensure roller clamp is closed.
	<ol style="list-style-type: none"> 3. Open door and load infusion set as follows: <ul style="list-style-type: none"> • Fit blue adaptor on infusion set into blue top set retainer. • Insert orange safety clamp (leaving slider extended) in the occluded position into orange retainer.
	<div style="border: 1px solid black; padding: 5px; display: flex; align-items: center;"> <p>Pushing on the Safety Clamp Slider may lead to uncontrolled flow to the patient. Therefore, always close the roller clamp before pushing on the safety clamp slider.</p> </div>
	<ol style="list-style-type: none"> 4. Ensure infusion set is fully inserted into tubing guide.
	<ol style="list-style-type: none"> 5. Close door and open roller clamp. Ensure no drops are falling in the drip chamber.
<ol style="list-style-type: none"> 6. Ensure all air is removed from the set. Connect the infusion set to the patient access device. 	

Starting the Infusion



PRIME AND LOAD THE SET (Refer to 'Loading an Infusion Set')

1. Ensure the pump is connected to an AC power supply (also operates from battery).
2. Connect flow sensor, if required. (See 'Flow Sensor Operation' section)
3. Press the key.
The pump will run a short self-test. Check two beeps are activated during this test. Check the displayed date and time are correct. Check display shows the data set name and version number. NOTE: The pump starts up and displays previous settings.
4. Confirm current **PROFILE** -
 - a) Selecting **CHANGE** will display the profile selection screen, select profile using keys and press **OK** softkey to confirm. Profile screen will display again, press **KEEP** softkey and **SELECT** screen will be displayed, go to step 6.
 - b) Selecting **KEEP** go to step 5.**NOTE: Profile screen is only shown if more than one profile is available in the data set.**

- No Drug Name
- ml/h
- Drug Name*

CLEAR SETUP?	
RATE	300 ml/h
VTBI	46.5 ml
VOLUME	3.5 ml
CLEAR	KEEP

- Drug Protocol
- Dosing Only

CLEAR SETUP?	
RATE	150 ml/h 1.50 mg/h
CONC	0.01 mg/ml
VOLUME	1.4 ml
CLEAR	KEEP

- Primary/Secondary
- Drug Names*

CLEAR SETUP?	
RATE	300ml/h
VTBI	50.0ml
VOLUME	0.0ml
FentanYl <small>SECONDARY</small>	
RATE	1.0ml/h
VTBI	1.0ml
CLEAR	KEEP

5. **CLEAR SETUP?** - Selecting **KEEP** will retain all previous rate and volume settings, go to step 7. Selecting **CLEAR** will automatically reset the rate and volume settings to zero and the **SELECT** screen will be displayed (if configured).

SELECT	
ml/h	
DOSING ONLY	
DRUGS	A B C D E F G H I J K L M N O P Q R S T U V W X Y Z
SELECT WITH	
OK	

6. Select either **ml/h**, **DOSING ONLY** or **DRUGS (A-Z)** and press **OK** to confirm. Then follow the prompts as required. (Refer to 'Basic Features -Drugs and Dosing' section)
7. Clear **VOLUME** infused , if required. (Refer to 'Clear Volume Infused' section, this is recommended for a new patient or when a new infusion is set-up.)
8. Enter **VTBI** (if required) by selecting **VTBI** softkey on main display. Set **VTBI** by using the **BAGS** option and/or keys and press **OK** to confirm. (Refer to 'Setting a VTBI' or 'Setting VTBI over Time' section)
9. Enter or adjust the **RATE** (if necessary) using the keys.
10. Press key to start the infusion. **INFUSING** will be displayed.

NOTE: The green run LED will flash to show that the pump is infusing.



If the infusion requires to be stopped immediately, the following actions may be applied:

- by pressing the key (recommended action)
- by closing the roller clamp
- by opening the door

* If a drug name is selected, then '**CLEAR SETUP?**' will alternate with the drug name. If secondary infusions have been enabled in the data set, then '**PRIMARY**' may also alternate.

Basic Features

Drugs and Dosing

The following options enable the pump to be set-up for use with a specific drug name and/or drug protocol. Drugs are pre-configured in the Guardrails® Editor to enable rapid selection of the drug name, dosing units and default rate. For increased security using a configured drug, maximum and minimum safety limits are programmable for concentration and dose rates. (Using the Guardrails® Editor software)



When adjusting an infusion using the dose rate, the display may not show any corresponding changes to the infusion rate in ml/h. This does not affect the accuracy of the infusion.

Selecting the INFUSION SETUP

1. Press the button to first access the options menu.
2. Drugs and dosing set-up options are available by selecting **INFUSION SETUP** from the list using the keys.
3. Select from the list of the options (**ml/h**, **DOSING ONLY** or **DRUGS**) as detailed below and press the **OK** softkey to confirm the selection.

SELECT	
ml/h	
DOSING ONLY	
DRUGS	A B C D E F G H I J K L M N O P Q R S T U V W X Y Z
SELECT WITH	
OK	QUIT

ml/h

1. Select **ml/h** from the list using the keys (if necessary).
2. Press **OK** to confirm.
3. Enter the ml/h rate as prompted on the display in the next screen.

SELECT	
ml/h	
DOSING ONLY	
DRUGS	A B C D E F G H I J K L M N O P Q R S T U V W X Y Z
SELECT WITH	
OK	QUIT

Dosing Only

1. Select **DOSING ONLY** from the list using the keys.
2. Press **OK** to confirm.
3. Select the dosing units from the list using the keys, press **OK** to confirm.
4. Enter **WEIGHT**¹ using the keys, press **OK** to confirm.
5. Use the keys to select the **TOTAL VOLUME**², press **OK** to confirm.
6. Enter **DRUG AMOUNT** using the keys and if units need to be changed, select **UNITS** which will scroll through the units available. Press **OK** to confirm selection.
7. A summary of the **DOSING ONLY** information is displayed, to **CONFIRM?** all details shown press **OK**. The **BACK** softkey may be used at any time to return to the previous screen.

¹ - Only displayed if weight based units are used.

² - Total Volume = Drug Volume + Diluent Volume i.e. Total Volume of fluid in the fluid container after a drug is added.

SELECT	
ml/h	
DOSING ONLY	
DRUGS	A B C D E F G H I J K L M N O P Q R S T U V W X Y Z
SELECT WITH	
OK	QUIT

Drugs

1. Select the required **DRUGS** alphabetical row from the list using the keys.
2. Press **OK** to confirm.
3. Select the drug from the displayed list using the keys, press **OK** to confirm.
4. Enter **WEIGHT**¹ using the keys, press **OK** to confirm.
5. Use the keys to enter the **TOTAL VOLUME**², press **OK** to confirm.
6. Enter **DRUG AMOUNT** using the keys, press **OK** to confirm selection.
7. A summary of the **DRUG** information is displayed, to **CONFIRM?** all details shown press **OK**. The **BACK** softkey may be used at any time to return to the previous screen.

¹ - Only displayed if weight based units are used.

² - Total Volume = Drug Volume + Diluent Volume i.e. Total Volume of fluid in the fluid container after a drug is added.

VOLUME	
VOLUME INFUSED	
374 ml	
CLEAR	QUIT

Clear Volume Infused









This option enables the volume infused to be cleared.

1. Press the **VOLUME** softkey on main display to show the clear **VOLUME INFUSED** option.
2. Press the **CLEAR** softkey to clear the volume infused. Press the **QUIT** softkey to retain the volume.

 **When a new drug or a new concentration has been setup and the previous volume infused has not been cleared, then the message DOSE INFUSED HAS BEEN CLEARED will be displayed.**

VTBI	
↑	1500ml
	1000ml
	500ml
	250ml
	200ml
	100ml
	50ml
	0ml (OFF)
SELECT WITH	⬆ ⬇ ⬅
OK	BACK

Setting a VTBI

1. Using the   keys:
 - a) Press the **VTBI** softkey on main display to enter the volume to be infused screen.
 - b) Enter the volume to be infused using the   keys and press **OK** to confirm.
- OR**
2. Using the **BAGS** softkey:
 - a) Press the **VTBI** softkey on main display to enter the volume to be infused screen.
 - b) Select the **BAGS** softkey, select the required bag volume using the   keys and press **OK** to confirm the selection.
 - c) Press **OK** to confirm again, or adjust the **VTBI** using the   keys.

NOTE: On completion of VTBI pump will continue to infuse at KVO rate.

VTBI DONE	
INFUSING KVO	
CANCEL	

KVO	
RATE	5.0 ml/h
VTBI	0.0 ml
VOLUME	2.0 ml
 0 h 00 m 00 s	
VOLUME	



KVO (Keep Vein Open) Rate

At the end of VTBI, the pump will first display **VTBI DONE/INFUSING KVO**. Press **CANCEL** to display **KVO** screen.

The pump continues to infuse at a very low (Default) rate. KVO is used to keep the patients vein open, in order to prevent blood clots and catheter occlusions.

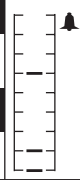

NOTE: If the KVO rate (Default 5ml/h) is greater than the set infusion parameters then the pump will continue to infuse at the set infusion rate. The KVO rate will flash on screen to indicate this is not the usual infusion rate.

The pump will beep every 5 seconds while in KVO mode.

PRESSURE	
PUMPING PRESSURE	
 L1	
ALARM LIMIT	
 L5	
ADJUST WITH	⬆ ⬇ ⬅
OK	

Pressure

To check and adjust the pressure level, press the  button. The display will change to show the current pumping pressure level and the pressure alarm limit. The pressure alarm limit can be set via the Guardrails® Editor.

1. Press the   keys to increase or decrease the alarm limit (L2, L5 or L8). The new limit will be indicated on the display.
2. Press **OK** to exit the screen.

 **The pressure alarm limit is auto adjusted and is fixed at level 8 (L8) for rates above 200ml/h.**

The interpretation of pressure readings and occlusion alarms are the responsibility of the clinician depending on the specific application.

Occlusion levels for the Alaris® GP Guardrails® Volumetric Pump are configured in the Data Set Editor by profile only.

BOLUS	
RATE SET WITH	80 ml/h
VOLUME	0.0 ml
↓ HOLD KEY BELOW	
BOLUS	QUIT

Bolus Infusions

Bolus - Administering a controlled volume of fluid or drug at an increased rate for diagnostic or therapeutic purposes. The pump should always be infusing and always attached to the patient. (Drugs given by an IV bolus could achieve immediate and high drug concentration levels.)

The bolus feature can be configured via the Guardrails® Editor to:

- a) Bolus Mode - Disabled
- b) Bolus Mode - Hands-On Only

Bolus Mode - Disabled

If configured to *Disabled*, pressing the button will have no effect and the pump will continue to infuse at the set rate.



A Bolus cannot be administered if the feature is disabled for the selected data set or specific drug. During BOLUS the pressure limit alarm is temporarily increased to the maximum level (L8).

Bolus Mode - Hands-On Only

Press and hold the (flashing) **BOLUS** softkey to deliver the required bolus. The bolus rate can be adjusted. The bolus volume is limited in the configuration via Guardrails® Editor.

1. During infusion press the button once to display the bolus screen.
2. Use the keys to adjust the bolus rate if required.
NOTE: Rate may be restricted by the **Bolus Rate Max** which is configured in the Guardrails® Editor.
3. To deliver the bolus press and hold the **BOLUS** softkey. During the bolus, the volume being infused is displayed. When the desired bolus volume has been delivered or the bolus volume limit is reached, release the softkey. The bolus volume is added to the total volume infused displayed.



If the volume to be infused (VTBI) is reached during a bolus, the VTBI complete alarm will sound. Press to silence the alarm or CANCEL to acknowledge the alarm. See VTBI section for more details on VTBI operation. When using infusion set 63280NY the maximum infusion rate is 150ml/h.

TITRATE	
PRESS TO CONFIRM	
RATE	25.0 ml/h 16.7 µg/kg/24h
VTBI	45.0 ml
VOLUME	50.0 ml
⌚ 1 h 48 m 00 s	
QUIT	

Rate Titration

If Rate Titration is **enabled** (via the Guardrails® Editor) the infusion rate or dose rate (if available) can be adjusted **while infusing**.

1. Select the new rate using the keys.
The message <TITRATE PRESS TO CONFIRM > will flash on screen and the pump continues to infuse at the original rate.
2. Press the button to confirm the new infusion rate and start infusing at the new rate.

If Rate Titration is **disabled** the rate can only be adjusted **whilst ON HOLD**:

1. Press the button to put the pump **ON HOLD**.
2. Select the new rate using the keys.
3. Press the button to start infusing at the new rate.

Basic Features (continued)

Rate Lock (If Enabled)

If Rate Lock is enabled, when the infusion rate has been set and the infusion started (or following a bolus infusion) the rate lock prompt will appear on the main display.

To select the rate lock function press the **YES** softkey. Press the **NO** softkey if the rate lock is not required.

When rate lock is enabled, the following are unavailable:

- **Changing the infusion rate / titration**
- **Bolus**
- **Switching the pump off**
- **VTBI over time infusions.**
- **Secondary infusions (if enabled)**



To turn rate lock off:

1. Press the  button to access the options menu.
2. Select **UNLOCK RATE** and press the **OK** softkey.

To turn rate lock on:

1. Press the  button to access the options menu.
2. Select **RATE LOCK** and press the **OK** softkey.



Adjusting Existing Dosing or Protocol Infusions - Set By ml/h / Set By Doserate

To set doserate or flowrate in precise increments it may be necessary to switch between the rate adjust options **SET BY DOSERATE** and **SET BY ml/h**. An arrow to the left of the rate display shows the rate changed when the   keys are used to increase/decrease the infusion rate.



To set a doserate precisely the arrow must be pointing to the doserate (for example: mg/kg/h); the flowrate will be calculated from the doserate.

To precisely set a flowrate the arrow must be pointing to flowrate (ml/h); the doserate will be calculated from the flowrate.

Selecting the SET BY ml/h Option

1. Press the  button to access the options menu.
2. Select the **SET BY ml/h** option using the   keys and press the **OK** softkey indicated on the screen. This will select the set by flowrate option, the arrow on the display will automatically select the flowrate, the flowrate can be adjusted if necessary.

Selecting the SET BY DOSERATE Option

1. Press the  button to access the options menu.
2. Select the **SET BY DOSERATE** option using the   keys and press the **OK** softkey indicated on the screen. This will select the set by doserate option, the arrow on the display will automatically select the doserate, the doserate can be adjusted if necessary.

Dosing Summary

To review currently selected dosing information:

1. Press the  button to first access the options menu.
2. Select **DOSING SUMMARY**.
3. Review the information and then press the **QUIT** softkey.

Infusion Setup

To change the Infusion Setup, refer to 'Basic Features - Drugs and Dosing, Selecting the INFUSION SETUP' section.

Drug Name Only







This feature adds a drug name to an existing infusion, when infusing using ml/h or dosing only options.

1. Press the  button to access the options menu.
2. Select **DRUG NAME ONLY**.
3. Press the **OK** softkey to confirm the drug name or press the **QUIT** softkey to exit the option.

Basic Features (continued)



Clear Drug Name

Clearing the drug name is only available if drug name only has been selected:

1. Press  to put the pump **ON HOLD**.
2. Press the  button to access the options menu.
3. Select **DRUG NAME ONLY** using the   keys, press **OK** to confirm.
4. Select **CLEAR DRUG NAME** (displayed if a name only is selected) using the   keys. Press the **OK** softkey to confirm the selection.







Primary Setup

If a secondary infusion has already been setup (see 'Secondary (Piggyback) Infusions' section), then access to the primary infusion setup is as follows:

1. Press  to put the pump **ON HOLD**.
2. Press the  button to access the options menu.
3. Select **PRIMARY SETUP** and press the **OK** softkey to confirm. Make changes to the primary setup as necessary.



Setting VTBI over Time

This option allows a specific VTBI and delivery time to be set. The rate necessary to deliver the required volume within the specified time is calculated and displayed.

1. Stop the infusion. Press  button to access the options menu.
2. Select the **SET VTBI OVER TIME** option using the   keys and press the **OK** softkey.
3. Adjust the volume to be infused using the   keys. (Or select **BAGS** softkey to set the VTBI) When the desired volume has been reached press the **OK** softkey.
4. Enter the time over which the volume is to be infused using the   keys. The infusion rate will automatically be calculated.
5. Press **OK** softkey to enter the value or **BACK** to return to the VTBI.

Adjust Alarm Volume

This option allows adjustment of the volume if enabled.

1. Press the  button to access the options menu.
2. Select **ADJUST ALARM VOLUME**.
3. Select **HIGH**, **MEDIUM** or **LOW** using the   keys.
4. Press **OK** softkey to confirm or **QUIT** to exit screen.

Pump Details

To review pump information:

1. Press the  button to access the options menu.
2. Select **PUMP DETAILS**.
3. Review the information and then press the **QUIT** softkey.

Basic Features (continued)

Changing the Infusion Set

1. Press  to put the pump **ON HOLD**.
2. Close in-line clamp and ensure the access to the patient is isolated.
3. Disconnect the infusion set from the patient.
4. Open pump door and remove infusion set from the pump and discard the set and fluid container according to hospital protocol.
5. Prepare the new infusion set, load infusion set into pump and close the door, see "Loading the Infusion Set".
6. Restart infusion, see "Getting Started".



When changing the infusion set or the fluid container use aseptic technique according to hospital protocol.

It is recommended that infusion sets are changed in accordance with the Directions For Use.

Carefully read the Directions For Use supplied with the infusion set prior to use.

The set change interval is up to 72 hours with the following exceptions;

- **Transfusion (Blood) Sets**
- **60953 Alaris® GP Low Sorbing Infusion Set**
- **60033E Alaris® GP Low Sorbing Infusion Set**
- **60950E Alaris® GP Oncology Infusion Set**

Changing the Fluid Container

1. Press  to put the pump **ON HOLD**.
2. Remove bag spike on infusion set from empty / used container. Discard empty / used container according to hospital protocol.
3. Insert spike into new container.
4. Squeeze the drip chamber approximately half full or up to fill line (if the drip chamber is marked) with fluid.
5. Restart infusion, see "Getting Started".



When changing the infusion set or the fluid container use aseptic technique according to hospital protocol.

It is recommended that infusion sets are changed in accordance with the Directions For Use.

Carefully read the Directions For Use supplied with the infusion set prior to use.

SmartSite® Needle-Free System Instructions

SmartSite® Needle-Free Valve is designed to permit safe gravity flow and automated flow, injection and aspiration of fluids without the use of needles by utilising Luer lock and luer slip connectors.



Precautions:

Discard if packaging is not intact or protector caps are unattached.

If Needle-Free Valve is accessed by a needle in an emergency the valve will be damaged causing leakage. Replace Needle-Free Valve immediately.

Needle-Free Valve contraindicated for blunt cannula system.

DO NOT leave slip luer syringes unattended.

DIRECTIONS - Use Aseptic Technique

1. Prior to every access, swab top of Needle-Free Valve port with 70% Isopropyl alcohol (1-2 seconds) and allow to dry (approximately 30 seconds).

NOTE: Dry time is dependent on temperature, humidity, ventilation of the area.

2. Prime valve port. If applicable, attach syringe to Needle-Free Valve port and aspirate minuscule air bubbles.
3. When used with administration sets always refer to individual set directions for use as change interval may vary according to clinical application (e.g. infusions of blood, blood products, and lipid emulsions).

NOTE: During use of Needle-Free Valve port, fluid may be observed between the housing and blue piston. This fluid does not enter the fluid path and requires no action.

NOTE: For product questions or needle-free valve educational materials, contact your CareFusion representative. Consult facility protocols. Consult other organizations that publish guidelines useful in developing facility protocols.

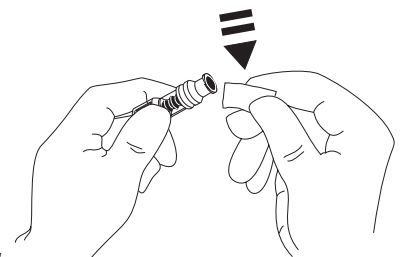

Secondary (Piggyback) Infusions

Secondary (or piggyback) Infusion mode is only available if it has been configured.

The application of secondary infusions should be limited to the intermittent therapy of medications which are not sensitive to the total time required to complete an infusion.



- Typically antibiotics may be infused using a secondary infusion, where the primary infusion is limited to maintenance fluid. If intending to use the secondary infusion facility, the primary infusion should be a maintenance fluid only and is not indicated for drug therapy.
- The application of secondary infusions for delivery of critical drugs, particularly those with a short half life, is NOT indicated for use. These drugs should be administered through a dedicated pump channel.
- Dependent upon factors such as fluid viscosity, the secondary infusion rate, head height between the secondary and primary fluid containers and the use of clamps, flow may occur from the primary fluid container during a secondary infusion. This could result in drug remaining in the container at the end of the secondary infusion, delaying its delivery for a period of time which is dependent upon the primary infusion rate. For example, a secondary infusion of 250ml at 300ml/h could result in approximately 33ml remaining, requiring up to 25 minutes additional time to complete the delivery, assuming a primary infusion rate of 80ml/h (and the use of a 72213N-0006 secondary infusion set and its supplied extension hook). Therefore it is recommended that flow sensors (if used) are disconnected from the pump during secondary infusions.
- Regular monitoring for unexpected primary flow is recommended. If flow from the primary fluid container is not desired during secondary infusion and/or the patient is sensitive to fluid balance, the clamp on the primary infusion set should be closed. Check that no drops fall in the primary drip chamber.
- On completion of the primary infusion the pump will continue at Keep Vein Open rate (KVO) rate.

Setting up a secondary infusion:

1. Ensure Primary infusion has been setup in ml/h (rate > 0ml/h).
2. Press to put the pump ON HOLD.
3. Press to access the **OPTIONS** screen.
4. Select **SECONDARY SETUP**, press **OK** to confirm.
5. Select either **NO DRUG NAME** or **DRUGS A-Z**. Press **OK** to confirm either selection.
6. Enter the secondary **RATE** using the keys.
7. Press **OK** to confirm.
8. Set **VTBI** using the keys. (Refer to 'Setting a VTBI' section)
9. Press **OK** to confirm.
10. Review **PRIMARY/SECONDARY** setup summary.
11. If correct, press **OK** to continue, or **BACK** to adjust **VTBI** or **RATE** of the **SECONDARY** mode.

12. Press to start the infusion in secondary mode.

An **ADVISORY** screen will be displayed - **ENSURE SECONDARY INFUSION SET OPEN**.

13. Press **OK** to start infusing at the displayed rate.

Setting up a subsequent secondary infusion:

On completion of the secondary VTBI, the pump will automatically transition to the primary infusion. (An audible 'BEEP' will be heard)

1. Press to place the primary infusion ON HOLD.
2. Follow instructions 3 to 13 of 'Setting up a secondary infusion'.

Typical Secondary infusions:

IV Pole

Extension Hook (approx.26cm)

Normally included with the secondary Infusion set.
Primary fluid container must hang lower to allow the secondary infusion to run and primary infusion to restart on completion of the secondary infusion.

Primary Fluid Container

Primary Infusion set

e.g. 63420E with an upper Y-Site (SmartSite® Needle-Free Valve).

In-line Clamp

Check Valve

Prevents secondary infusions from flowing back up the primary Infusion set instead of to the patient.

Ensure primary set has a backcheck valve upstream from the Y-site.

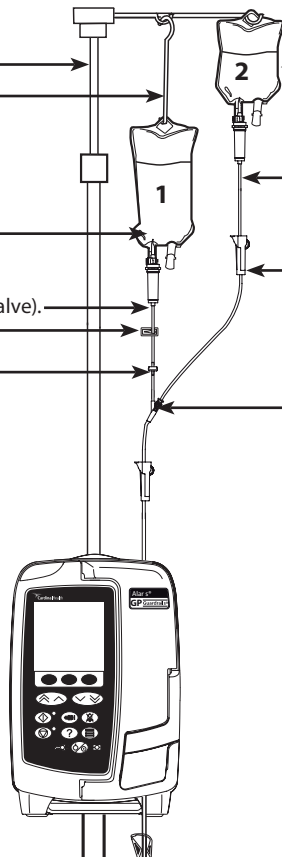

Secondary Fluid Container

Usually a smaller container e.g. 50ml, 100ml, 200ml or 250ml.

Secondary Infusion Set

e.g. 72213N-0006. Usually shorter tubing to reach the Y-site on the primary Infusion set.

In-line Clamp

e.g. roller clamp.

Upper Y-Site (SmartSite® Needle-Free Valve) on Primary Infusion Set.

The secondary set connects to the upper Y-connection on the primary Infusion set.

Service Configuration Mode

This section comprises of a list of options which can be configured. Some can be entered via the pump **SERVICE CONFIGURATION** menu (available in Technician Mode) and others through the Guardrails® Editor Software.

Enter the access code on Alaris® GP Guardrails® Volumetric Pump for **SERVICE** mode, then select **SERVICE CONFIGURATION**, see the Technical Service Manual for details.

Use Guardrails® Editor to configure the *pump configuration, drug list* and *units* enabled for each data set.



Access codes should only be entered by qualified technical personnel.

Date & Time

1. Select **DATE & TIME** from the **SERVICE CONFIGURATION** menu using the keys and press the **OK** softkey.
2. Press the **OK** softkey to confirm.
3. Use the keys to adjust the date displayed, pressing the **NEXT** softkey to access the next field.
4. When the correct date and time are displayed press the **OK** softkey to return to the **SERVICE CONFIGURATION** menu.
5. Press the **QUIT** softkey to return to the **SERVICE** menu and press to exit and power down.

Pump Reference Text

This option is used to add reference text to be shown on the pump start up display.

1. Select **PUMP REFERENCE** from the **SERVICE CONFIGURATION** menu using the keys and press the **OK** softkey.
2. Use the keys to enter the text and **NEXT** to move to the next character.
3. When the desired text has been selected press **OK** softkey to return to the **SERVICE CONFIGURATION** menu.
4. Press **QUIT** to exit back to the main **SERVICE** menu and press to exit and power down.

Language

This option is used to set the language of messages shown on the pump display.

1. Select **LANGUAGE** from the **SERVICE CONFIGURATION** menu using the keys and press the **OK** softkey.
2. Use the keys to select the language.
3. When the desired language has been selected press **OK** softkey to return to the **SERVICE CONFIGURATION** menu.
4. Press **QUIT** to exit back to the main **SERVICE** menu and press to exit and power down.

Backlight & Contrast

This option is used to set the backlight and contrast on the pump display.

1. Select **BACKLIGHT & CONTRAST** from the **SERVICE CONFIGURATION** menu using the keys and press the **OK** softkey.
2. Use the keys to adjust **BACKLIGHT, CONTRAST & DIMMING**. The contrast of the display will change when scrolling through the numbers. (Use **PARAM** to scroll between each option)
3. When the desired value has been reached press the **OK** softkey, then **QUIT** to get back to the **SERVICE** menu and press to exit and power down.

Pump Configuration available via the Guardrails® Editor Software

The following options are only configurable via the Guardrails® Editor Software (PC based), see Guardrails® Editor help files for further details.

GENERAL SETTINGS:

AC Fail Warning	Controls whether, when main power has been disconnected, a warning is generated to inform the user that the pump is operating solely on battery power.
Alarm Volume	Controls the audio volume of the pump used for alarms and warnings.
Alarm Volume Adjustable	Controls whether the user is able to adjust the 'Alarm Volume' setting.

DOWNSTREAM OCCLUSION SETTINGS:

Occlusion Limit Default	The default downstream occlusion limit.
Occlusion Limit Max	The maximum permitted downstream occlusion limit.

RATE SETTINGS:

Rate Titration	Allows the adjustment of the infusion rate while the pump is infusing, without putting the pump on hold.
Infusion Rate Max	The maximum permissible infusion rate.
Rate Lock	Controls whether the Rate Lock feature is available for use.

BOLUS SETTINGS:

Bolus Mode	Controls whether or not the pump allows bolus delivery.
Bolus Rate Max	The maximum permissible bolus rate.
Bolus Rate Default	The default value for bolus rates.
Bolus Volume Max	The maximum permissible bolus volume.

PATIENT SETTINGS:

Weight Default	The default patient weight.
Weight Soft Min	The minimum patient weight for weight-based drug dosing calculations before alerting the user.
Weight Soft Max	The maximum patient weight for weight-based drug dosing calculations before alerting the user.

AIR-IN-LINE SETTINGS:

AIL Limit	The single bubble Air-in-line alarm setting.
------------------	--

VTBI SETTINGS:

Primary VTBI Max	The maximum VTBI for primary infusions.
-------------------------	---

SECONDARY INFUSION SETTINGS:

Secondary Infusion	Allows the use of a secondary infusion (Piggyback) in the same channel.
Sec. VTBI Max	The maximum permissible setting for the Volume To Be Infused for secondary infusions.
Sec. Infusion Rate Max	The maximum permissible infusion rate for secondary infusions.

Drug List available via the Guardrails® Editor Software

The following drug parameters are only configurable via the Guardrails® Editor Software (PC based), see Guardrails® Editor help files for further details.

CONCENTRATION SETTINGS:

Concentration Units	The unit for concentration parameters.
Concentrations	The concentrations defined for this drug. The calculated value of drug amount / total volume.
Units Only	Permits the user to attach a range of concentration limits to a drug name. The concentration can then be defined on the pump by the user, within the min and max limits.
Concentration Min	The weakest permissible concentration for this drug.
Concentration Max	The strongest permissible concentration for this drug.

DOSE RATE SETTINGS:

Weight Based Units	Controls whether dose rate units are weight based or non-weight based.
Dose Rate Default	The default dose rate for infusing this drug.
Dose Rate Soft Max	The maximum permissible dose rate which does not generate an alert on the pump.
Dose Rate Units	The unit for dose rate parameters.
Dose Rate Soft Min	The minimum permissible dose rate which does not generate an alert on the pump.
Dose Rate Hard Max	The maximum permissible dose rate for infusing this drug.

BOLUS SETTINGS:

Bolus Mode	Controls bolus delivery method. These settings override the pump configuration settings in the profile.
Bolus Rate Default	The default value for bolus rate for this drug.
Bolus Dose Hard Max	The maximum permissible bolus dose for this drug.
Bolus Dose Units	The unit for bolus dose parameters.

Display of Units:



Units are selected via the Data Set Editor.

Micrograms can be displayed as mcg or µg depending upon the configuration in the Data Set Editor.

Units can be displayed as U or units depending upon the configuration in the Data Set Editor.

Alarms

Alarms **stop the infusion** and are indicated by a combination of an audible sound, flashing red alarm indicator and a message on the display.

1. Check the display for an alarm message and review table below for cause and action. Press  to silence the sound for 2 minutes, **CANCEL** to clear the message.
2. When the cause of the alarm has been rectified, press the  key to resume the infusion. (Exceptions are **DO NOT USE & BATTERY EMPTY**)

Display	Infusion Status	Cause	Action
AIR IN LINE	Infusion stopped	Single air bubble exceeds alarm limit. Set not fitted correctly into air in line detector.	<ul style="list-style-type: none"> • Assess the amount of air detected by air in line detector. • Opening the door may cause an air bubble to rise in the set. Check set for air. • Remove air according to hospital policy. • Ensure set is fitted correctly in the air in line detector. • Check level of fluid in container. • Check enough fluid left in drip chamber. • Restart infusion.
AIR IN LINE	Infusion stopped	Accumulated air bubbles exceeds alarm limit. (Multiple bubbles smaller than the single bubble alarm limit, which has been detected over a 15 min. window and >1ml.)	<ul style="list-style-type: none"> • Review infusion set for air bubbles and take appropriate action. • Check level of fluid in container. • Check enough fluid left in drip chamber. • Restart infusion.
DOOR OPEN	Infusion stopped	Door was opened during an infusion.	<ul style="list-style-type: none"> • Close door or clamp infusion set using roller clamp. • Restart infusion.
DOWNSTREAM OCCLUSION	Infusion stopped	A blockage has occurred downstream.	<ul style="list-style-type: none"> • Check fluid path between pump and patient for clamps, connectors, kinks or blockages. • Examine access site for signs of complications (redness, swelling, pain, heat).
UPSTREAM OCCLUSION	Infusion stopped	A blockage has occurred upstream. Possible container empty.	<ul style="list-style-type: none"> • Check set above the pump. • Check all clamps above pump. • Check fluid level in container. • Ensure drip chamber is half filled. • Ensure that the bag spike is inserted correctly. • Ensure air vent on drip chamber is open on all glass and semi rigid containers.
NO FLOW	Infusion stopped	Flow sensor detects no flow.	<ul style="list-style-type: none"> • Check flow sensor. • Check fluid level in container. • Ensure all clamps above pump are open. • Ensure drip chamber is half filled. • Ensure that the bag spike is inserted correctly. • Check flow sensor is clean.
FLOW ERROR	Infusion stopped	Gross difference between detected drops and expected amount of drops.	<ul style="list-style-type: none"> • Clamp infusion set using roller clamp. • Check flow sensor. • Check fluid level in drip chamber.
FLOW ERROR (In secondary infusion mode only)	Infusion stopped	Unexpected drops detected.	<ul style="list-style-type: none"> • Hang secondary container above primary. • Check drops are from secondary container when infusing. • Flow sensor disconnection is recommended.
FREE FLOW	Infusion stopped	Uncontrolled flow possible.	<ul style="list-style-type: none"> • Clamp infusion set using roller clamp. • Remove pump from use.
BATTERY EMPTY	Infusion stopped	The internal battery is exhausted. The pump will automatically switch off in the immediate future.	<ul style="list-style-type: none"> • Connect to power supply immediately or switch pump off.
SAFETY CLAMP	Pump on hold	Safety clamp broken or missing.	<ul style="list-style-type: none"> • Clamp infusion set using roller clamp. • Replace infusion set. • Investigate and correct set loading.
SET MISLOAD	Pump on hold	Set loaded incorrectly.	<ul style="list-style-type: none"> • Clamp infusion set using roller clamp. • Investigate and correct set loading.
FLOW SENSOR DISCONNECT	Infusion stopped	Flow sensor unplugged during infusion.	<ul style="list-style-type: none"> • Check / replace flow sensor or set VTBI.

Alarms (Continued)

<i>Display</i>	<i>Infusion Status</i>	<i>Cause</i>	<i>Action</i>
WRONG SET	Pump on hold	Safety clamp not detected.	<ul style="list-style-type: none"> • Clamp infusion set using roller clamp. • Check set and close door. • Replace infusion set. (If necessary)
DOOR CLOSE INCOMPLETE	Pump on hold	Safety clamp in non-occluded position with door open or obstructed.	<ul style="list-style-type: none"> • Clamp infusion set using roller clamp. • Investigate and correct set loading. • Close door.
DO NOT USE	Pump on hold / infusion stopped	Internal error has occurred.	<ul style="list-style-type: none"> • Remove pump from use.
LEVER OPEN	Infusion stopped	Door lever is open	<ul style="list-style-type: none"> • Check door lever. • Check lever hooks. • Check lever is not obstructed, if so, free obstruction.

Warnings

Warnings **alert the user but may not stop the infusion** and are indicated by an audible sound, a flashing amber warning indicator and a message on the display or both.

1. Check the display for a warning message. Press  to silence the sound for 2 minutes, **CANCEL** to clear the message.
2. Rectify the cause of the warning or proceed with caution.

Warnings:

<i>Display</i>	<i>Infusion Status</i>	<i>Cause</i>	<i>Action</i>
BATTERY LOW	Infusion continues	Less than 30 minutes of battery life remaining.	<ul style="list-style-type: none"> • Connect to power supply. • Check power cable.
AC POWER FAIL	Infusion continues*	AC power disconnected or failed.	<ul style="list-style-type: none"> • Reconnect to power supply.
VTBI DONE	Infusing KVO	Intended VTBI completed.	<ul style="list-style-type: none"> • Set new VTBI or clear VTBI.
AIR-IN-LINE	Pump on hold	Air detected in infusion set at the start of infusion. Set not fitted correctly into air in line detector.	<ul style="list-style-type: none"> • Ensure set is fitted correctly in the air in line detector. • Assess air in infusion set. • Check fluid level in drip chamber. • Check level of fluid in container.
SET CLOCK	Pump on hold	Date / time not set.	<ul style="list-style-type: none"> • A qualified service engineer must set date / time. • Press cancel softkey to continue.
TITRATION	Infusion continues	Rate titration not confirmed.	<ul style="list-style-type: none"> • Confirm or cancel new rate.
RATE LOCK	Infusion continues	Rate lock not confirmed.	<ul style="list-style-type: none"> • Select YES or NO as required.
LOG FAILURE	Pump on hold	Unable to update event log.	<ul style="list-style-type: none"> • A qualified service engineer may need to service the pump.
SET SERIAL NUMBER	Pump on hold	Serial number not set.	<ul style="list-style-type: none"> • Contact a qualified service engineer to set the serial number.

* If pump was on hold the alarm will still be activated but this message will not be displayed.

Prompts and Advisories

Prompts **alert the user but may not stop the infusion** and are indicated by an audible sound, a flashing amber warning indicator and a message on the display or both.

1. Check the display for a prompt message. Press  to silence the sound for 2 minutes, **CANCEL** to clear the message.
2. Rectify the cause of the prompt or proceed with caution.

Prompts:

<i>Display</i>	<i>Infusion Status</i>	<i>Cause</i>	<i>Action</i>
ATTENTION	Pump on hold	Pump left on hold for 2 minutes without starting the infusion.	<ul style="list-style-type: none"> • Review pump setup. • Start infusion or turn off pump.
SET VTBI	Pump on hold	No VTBI / flow sensor.	<ul style="list-style-type: none"> • Set VTBI or fit flow sensor.
SET NOT FITTED	Pump on hold	No infusion set fitted.	<ul style="list-style-type: none"> • Fit infusion set.
LOCKED	Infusion continues	Rate change attempted whilst locked.	<ul style="list-style-type: none"> • Unlock rate to adjust infusion settings.

Advisories:

<i>Display</i>	<i>Infusion Status</i>	<i>Cause</i>	<i>Action</i>
DOSE WOULD EXCEED	Pump on hold (If titration is disabled) Infusion continues (If titrating)	Infusion rate set exceeds a Guardrails® soft limit.	<ul style="list-style-type: none"> • Check infusion setting. • To confirm OVERRIDE LIMIT? press YES. • To deny OVERRIDE LIMIT? press NO.
DOSE UNDER	Pump on hold (If titration is disabled) Infusion continues (If titrating)	Infusion rate/dose rate set is under a Guardrails® soft limit.	<ul style="list-style-type: none"> • Check infusion setting. • To confirm OVERRIDE LIMIT? press YES. • To deny OVERRIDE LIMIT? press NO.
DOSE NOT PERMITTED	Pump on hold (If titration is disabled) Infusion continues (If titrating)	Dose rate entered is greater than the dose rate hard maximum set.	<ul style="list-style-type: none"> • Check infusion setting and adjust to appropriate required rate.
RATE NOT PERMITTED	Pump on hold (If titration is disabled) Infusion continues (If titrating)	Infusion rate set exceeds a Guardrails® hard limit.	<ul style="list-style-type: none"> • Check infusion setting and adjust to appropriate required rate.
CONCENTRATION NOT PERMITTED	Pump on hold	Concentration set exceeds hard max limit, or is under hard minimum limit.	<ul style="list-style-type: none"> • Check concentration and adjust to a more appropriate amount.
WEIGHT ABOVE LIMIT	Pump on hold	Patient weight set exceeds a Guardrails® soft limit.	<ul style="list-style-type: none"> • Check weight setting. • To confirm CONFIRM? press YES. • To deny CONFIRM? press NO.
WEIGHT BELOW LIMIT	Pump on hold	Patient weight set is under a Guardrails® soft limit.	<ul style="list-style-type: none"> • Check weight setting. • To confirm CONFIRM? press YES. • To deny CONFIRM? press NO.

Restarting an Infusion following an Air-in-Line Alarm



The pump may be restarted by opening the door, assessing and removing any air from the tubing guide area and in the infusion set on the patient side of the pump (if required) according to hospital policy. Close the door and cancel the air-in-line alarm. Restarting the infusion will reactivate the air-in-line system and will alarm if the preset air-in-line limit is exceeded.

Flow Sensor Operation (Optional)



The flow sensor automatically monitors the infusion flow rate through the drip chamber. The flow sensor will cause the pump to alarm if a significant deviation from the infusion rate occurs. The flow sensor will also be able to detect empty containers. For this reason we recommend use of a flow sensor wherever possible excluding secondary infusions.

IVAC® Model 180 Flow Sensor

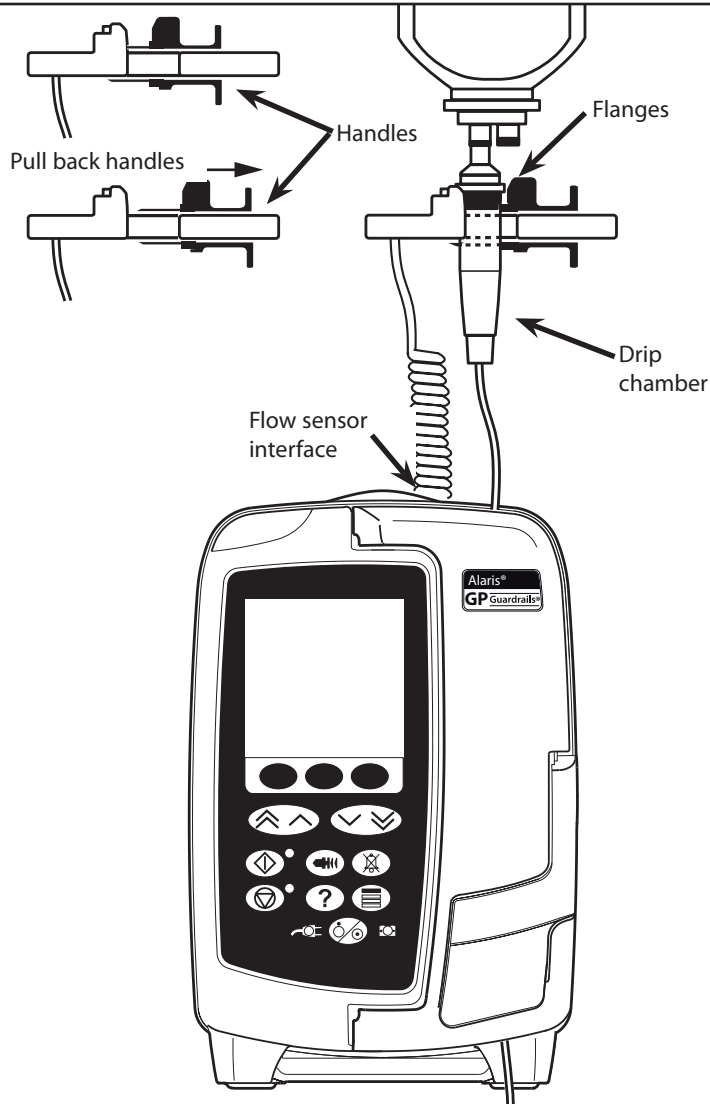

1. Plug the flow sensor into the flow sensor interface located on the top rear part of the pump.
2. Attach the IVAC® Model 180 Flow Sensor to the drip chamber of the infusion set, by pulling back the handles. Refer to the illustration above.
3. Proceed with load, priming, and set-up instructions as described in section "Getting Started".

NOTE: Ensure drip chamber is half full and upright.



*Always attach the flow sensor before you start an infusion .
Avoid using the flow sensor in direct sunlight.
Always ensure lens is clean.*

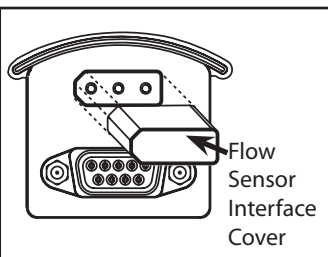



Always replace the flow sensor interface cover when the flow sensor is disconnected.

Infusion Sets

The Alaris® GP Guardrails® Volumetric Pump uses standard, single-use, disposable infusion sets. The user is responsible for verifying the suitability of a product used, if it is not recommended by CareFusion.

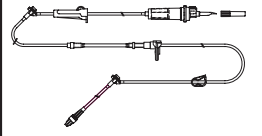
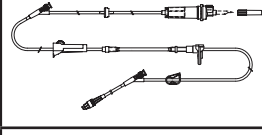
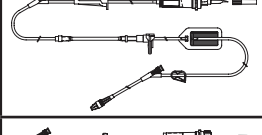
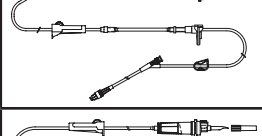
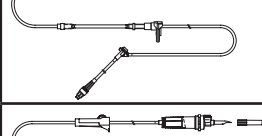
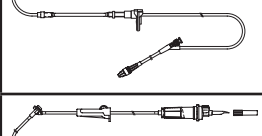
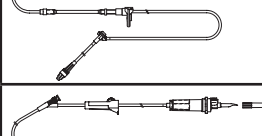
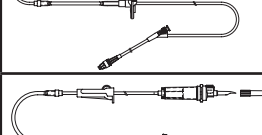
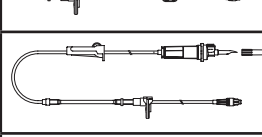
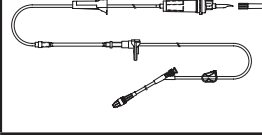
 **New sets are continuously being developed for our customers. Please contact your local CareFusion representative for availability.**

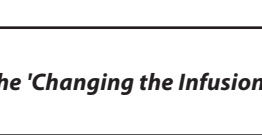
Alaris® GP standard infusion sets		
60073	<ul style="list-style-type: none"> • 2 Injection Ports • No Filter • Length: 260cm 	
60093E	<ul style="list-style-type: none"> • 2 SmartSite® Needle-Free Valve Ports. • 15 Micron Filter • 1 Backcheck Valve • Length: 260cm 	
60123E	<ul style="list-style-type: none"> • 2 SmartSite® Needle-Free Valve Ports. • 1.2 & 15 Micron Filter • Length: 265cm 	
60293E	<ul style="list-style-type: none"> • 2 SmartSite® Needle-Free Valve Ports. • 1 Backcheck Valve • No Filter • Length: 260cm 	
60693	<ul style="list-style-type: none"> • 1 Injection Port • 15 Micron Filter • Length: 255cm 	
60693E	<ul style="list-style-type: none"> • 1 SmartSite® Needle-Free Valve Port. • 15 Micron Filter • Length: 255cm 	
60793	<ul style="list-style-type: none"> • 2 Injection Ports • 15 Micron Filter • Length: 255cm 	
60793E	<ul style="list-style-type: none"> • 2 SmartSite® Needle-Free Valve Ports. • 15 Micron Filter • Length: 255cm 	
60903	<ul style="list-style-type: none"> • 15 Micron Filter • Length: 250cm 	
60593	<ul style="list-style-type: none"> • 15 Micron Filter. • Length: 260cm 	
60173E	<ul style="list-style-type: none"> • 1 SmartSite® Needle-Free Valve Port. • No Filter • Length: 260cm 	
63120V	<ul style="list-style-type: none"> • 1 Split Septum Injection Port • 1 Backcheck Valve • No Filter • Length: 305cm 	





Check infusion set materials and drug compatibility before selecting an infusion set. It is recommended that infusion sets are changed according to the instructions in the 'Changing the Infusion Set' section. Carefully read the Directions For Use supplied with the infusion set prior to use.

Please note these drawings are not to scale

Infusion Sets (Continued)

The Alaris® GP Guardrails® Volumetric Pump uses standard, single-use, disposable infusion sets. The user is responsible for verifying the suitability of a product used, if it is not recommended by CareFusion.

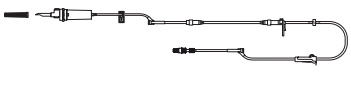
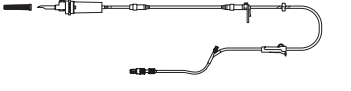
 **New sets are continuously being developed for our customers. Please contact your local CareFusion representative for availability.**

Alaris® GP standard infusion sets		
63200NY	<ul style="list-style-type: none"> • No Filter • Length: 260cm 	
63110V	<ul style="list-style-type: none"> • 2 Split Septum Injection Ports • No Filter • Length: 290cm 	
63401E	<ul style="list-style-type: none"> • 1 SmartSite® Needle-Free Valve Port • No Filter • Length: 275cm 	
63420E	<ul style="list-style-type: none"> • 2 SmartSite® Needle-Free Valve Ports • 1 Backcheck Valve • No Filter • Length: 295cm 	

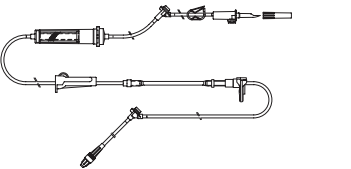
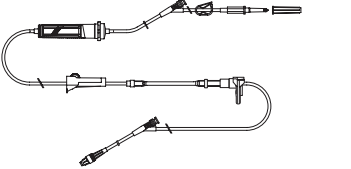
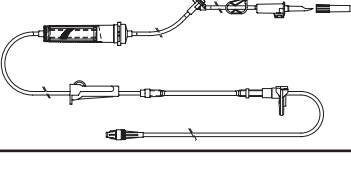
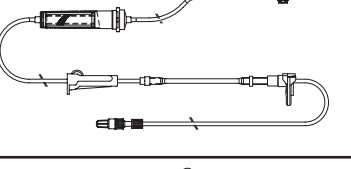
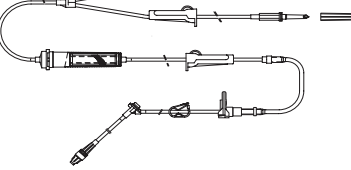
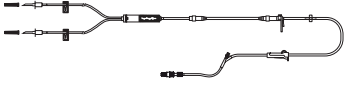
Alaris® GP blood infusion sets		
60393	<ul style="list-style-type: none"> • 2 Injection Ports • 200 Micron Filter. • Length: 270cm 	
60393E	<ul style="list-style-type: none"> • 2 SmartSite® Needle-Free Valve Ports. • 200 Micron Filter. • Length: 270cm 	
60893	<ul style="list-style-type: none"> • 1 Injection Port • 200 Micron Filter. • Length: 255cm 	
60894	<ul style="list-style-type: none"> • 1 Injection Port • 200 Micron Filter. • Length: 255cm 	
60980	<ul style="list-style-type: none"> • Twin Spike • 1 Injection Port • 200 Micron Filter. • Length: 250cm 	
63477E	<ul style="list-style-type: none"> • 2 Non-Vented Spikes. • 180 Micron Filter • Length: 305cm • 1 SmartSite® Needle-Free Valve Port. 	



Check infusion set materials and drug compatibility before selecting an infusion set. It is recommended that infusion sets are changed according to the instructions in the 'Changing the Infusion Set' section. Carefully read the Directions For Use supplied with the infusion set prior to use.



Please note these drawings are not to scale

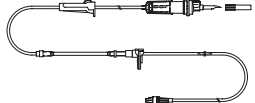

Infusion Sets (Continued)

The Alaris® GP Guardrails® Volumetric Pump uses standard, single-use, disposable infusion sets. The user is responsible for verifying the suitability of a product used, if it is not recommended by CareFusion.

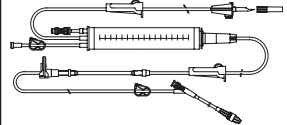
 **New sets are continuously being developed for our customers. Please contact your local CareFusion representative for availability.**

Alaris® GP light resistant infusion sets		
60643	<ul style="list-style-type: none"> • 15 Micron Filter. • PVC tubing • Length: 250cm 	

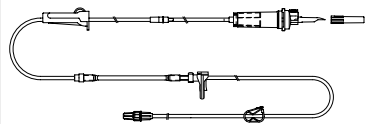
Alaris® GP burette infusion sets		
60103E	<ul style="list-style-type: none"> • 2 SmartSite® Needle-Free Valve Port. • 1 Burette (150ml). • Length: 270cm 	
63441E	<ul style="list-style-type: none"> • 4 SmartSite® Needle-Free Valve Port. • 1 Burette (150ml). • Length: 330cm 	

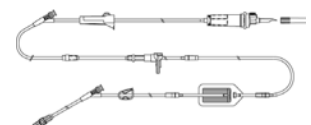
Alaris® GP low sorbing infusion sets		
60953	<ul style="list-style-type: none"> • 15 Micron Filter. • Polyethylene lined PVC tubing • Length: 260cm 	
63260NY	<ul style="list-style-type: none"> • Polyethylene lined PVC tubing • No Filter • Length: 295cm 	
60033E	<ul style="list-style-type: none"> • 2 SmartSite® Needle-Free Valve Ports. • 0.2 Micron Filter. • Length: 265cm 	



Check infusion set materials and drug compatibility before selecting an infusion set. It is recommended that infusion sets are changed according to the instructions in the 'Changing the Infusion Set' section. Carefully read the Directions For Use supplied with the infusion set prior to use.

Please note these drawings are not to scale



Infusion Sets (Continued)

The Alaris® GP Guardrails® Volumetric Pump uses standard, single-use, disposable infusion sets. The user is responsible for verifying the suitability of a product used, if it is not recommended by CareFusion.

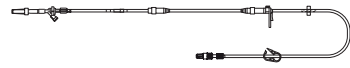
 **New sets are continuously being developed for our customers. Please contact your local CareFusion representative for availability.**

Alaris® GP syringe adapter infusion sets		
63280NY	<ul style="list-style-type: none"> • Length: 270cm  Restricted to maximum infusion rate of 150ml/h	

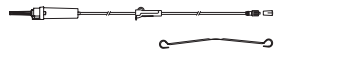
Alaris® GP oncology infusion sets		
60950E	<ul style="list-style-type: none"> • 5 SmartSite® Needle-Free Valve Ports. • 15 Micron Filter. • Length: 260cm 	

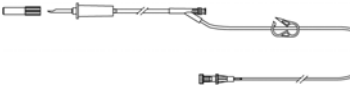
Alaris® GP secondary infusion set		
72213N-0006	<ul style="list-style-type: none"> • Male luer and hanger • Length: 76cm 	
72951NE (For use with 60950E)	<ul style="list-style-type: none"> • 1 SmartSite® Needle-Free Valve Port. • Male luer with Backcheck Valve. • Length: 71cm  Do not use with pump in secondary infusion mode when infusing critical drugs.	

 **Check infusion set materials and drug compatibility before selecting an infusion set. It is recommended that infusion sets are changed according to the instructions in the 'Changing the Infusion Set' section. Carefully read the Directions For Use supplied with the infusion set prior to use.**

Please note these drawings are not to scale

Associated Products

- The Alaris® DS Docking Station
- The Alaris® Gateway Workstation

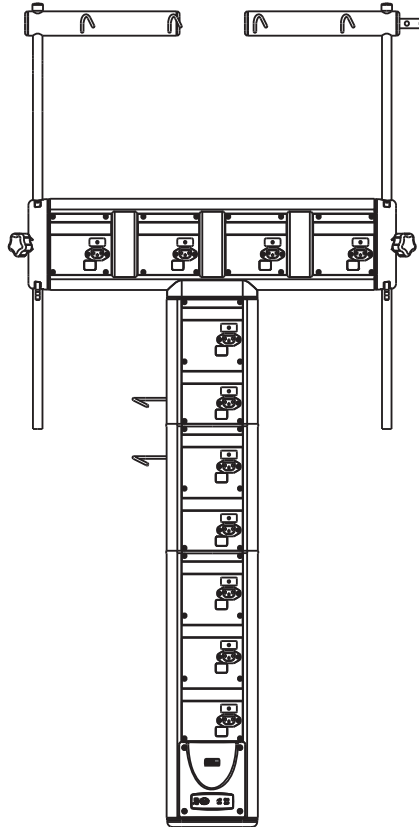
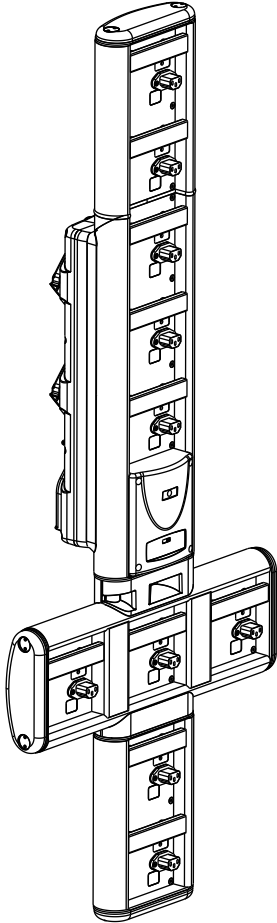

Maintenance

Routine Maintenance Procedures

To ensure that this pump remains in good operating condition, it is important to keep it clean and carry out the routine maintenance procedures described below.

Interval	Routine Maintenance Procedure
As per Hospital Policy	Thoroughly clean external surfaces of the pump before and after prolonged period of storage.
Each usage	<ol style="list-style-type: none">1. Inspect AC power supply plug and cable for damage.2. Inspect case, keypad and mechanism for damage.3. Check Start up self test operation is correct.
Before the transfer of the pump to a new patient and as required	Clean the pump by wiping over with a lint-free cloth lightly dampened with warm water and a standard disinfectant / detergent solution.



If the pump is dropped, damaged, subjected to excessive moisture or high temperature, immediately take it out of service for examination by a qualified service engineer.

All preventative and corrective maintenance and all such activities shall be performed at a compliant work place in accordance with the information supplied. CareFusion will not be responsible should any of these actions be performed outside the instructions or information supplied by CareFusion. For Preventative and Corrective Maintenance instructions please refer to the Technical Service Manual (TSM).

All servicing should only be performed by a qualified service engineer with reference to the TSM.



Please refer to Technical Service Manual for calibration procedures. The units of measurement used in the calibration procedure are standard SI (The International System of Units) units.

Battery Operation

The internal rechargeable battery allows continued operation when the AC power is unavailable, for example during patient transfer or AC power failure. Mean Time To Battery Empty from fully charged is a minimum of 6 hours. When connected to the AC power supply for 4 hours, (whether the pump is in use or not) a new battery pack will be fully charged.

The battery is maintenance free, sealed Nickel Metal Hydride and requires no routine servicing. However, to achieve optimum operation, ensure that the battery is fully recharged after full discharge, before storage, and at regular 3 month intervals during storage.

Charge retention will eventually degrade. Where retention is critical the internal battery should be replaced every 3 years.

It is recommended that only a qualified service engineer replaces the battery. For further information regarding the replacement of batteries refer to the Technical Service Manual.

The battery pack used in this Alaris® Volumetric Pump is manufactured by CareFusion® and includes a proprietary PCB (printed circuit board) designed specifically for the Alaris® Volumetric Pump, and in conjunction with Alaris® Volumetric Pump software, controls battery use, charge and temperature. Any use of battery packs that are not manufactured by CareFusion in the Alaris® Volumetric Pump is at your sole risk, and CareFusion does not provide any warranty for or endorsement on any battery packs that are not manufactured by CareFusion. CareFusion's product warranty shall not apply in the event the Alaris® Volumetric Pump has suffered damage or premature wear, or malfunctions or otherwise operates incorrectly, as a result of use with a battery pack that is not manufactured by CareFusion.

Cleaning and Storage

Cleaning the pump: -

Before the transfer of the pump to a new patient and periodically during the use, clean the pump by wiping over with a lint-free cloth lightly dampened with warm water and a standard disinfectant / detergent solution.



Before cleaning always switch off and disconnect from the AC power supply. Do not allow liquid to enter the casing and avoid excess fluid build up on the pump.

Do not use aggressive cleaning agents as these may damage the exterior surface of the pump. Do not steam autoclave, ethylene oxide sterilise or immerse this pump in any fluid.

Please ensure the membrane covering the pumping mechanism is intact prior to cleaning. If faulty, remove from use and contact a qualified service engineer.

Recommended cleaners are:

Brand	Concentration
Hibiscrub	20% (v/v)
Virkon	1% (w/v)

Do not use the following disinfectant types:

- NaDcc (such as PRESEPT)
- Hypochlorites (such as CHLORASOL)
- Aldehydes (such as CIDEX)
- Cationic Surfactants (such as Benzalkonium Chloride)
- Iodine (such as Betadine)
- Concentrated Isopropyl alcohol based cleaners will degrade plastic parts.

Storing the pump: -

If the pump is to be stored for an extended period it should be first cleaned and the internal battery fully charged. Store in a clean, dry atmosphere at room temperature and, if available, employ the original packaging for protection.

Once every 3 months during storage, carry out functional tests as described in the technical service manual and ensure that the internal battery is fully charged.

Cleaning and storing the infusion set: -

The infusion set is a disposable single use item and should be discarded after use according to hospital protocol.

Cleaning the door: -

Refer to the Technical Service Manual for information for removing the door to facilitate cleaning of the fluid path, the use of a screwdriver (torx) is required and should only be carried out by a qualified service engineer.

Cleaning the Flow Sensor: -

Before the transfer of the flow sensor to a new infusion set and periodically during use, clean the flow sensor by wiping over with a lint-free cloth lightly dampened with warm water and a standard disinfectant / detergent solution. Ensure the connector does not get wet. Dry flow sensor before use.

To aid cleaning of flow sensors which have been heavily soiled, contaminated or if the handle operation is not free moving, then the flow sensor may be immersed and soaked in clean soapy water (see ). The inside of the spring mechanism can be cleaned by activating it whilst submerged in the water.

After cleaning, the sensor should be allowed to dry fully prior to use.



The plug of the flow sensor must not be immersed in water as damage will occur.

Disposal

Information on Disposal for Users of Waste Electrical & Electronic Equipment

This  symbol on the product and/or accompanying documents means that used electrical and electronic products should not be mixed with household waste.

If you wish to discard electrical and electronic equipment, please contact your CareFusion affiliate office or distributor for further information.

Disposing of this product correctly will help to save valuable resources and prevent any potential negative effects on human health and the environment which could otherwise arise from inappropriate waste handling.

Information on Disposal in Countries outside the European Union

This symbol is only valid in the European Union. The product should be disposed of taking environmental factors into consideration. To ensure no risk or hazard, remove the internal rechargeable battery and the Nickel Metal Hydride battery from the control board and dispose of as outlined by the local country regulations. All other components can be safely disposed of as per local regulations.

Specifications

Electrical Protection

Class I, Type CF (Defibrillation-proof)

Electrical/Mechanical Safety

Complies with IEC/EN60601-1 and IEC/EN60601-2-24.

Electro Magnetic Compatibility (EMC)

Complies with IEC/EN60601-1-2 and IEC/EN60601-2-24.

Electrical Safety

Typical earth leakage current 78µA.

Typical Enclosure Leakage Current (Normal Condition) = 0µA

Typical Protective Earth Resistance = 32mOhms

The above measurements are for guidance only, IEC/EN60601-1 limits are defined below:

Earth Leakage Current (Normal Condition) <= 500µA

Enclosure Leakage Current (Normal Condition) <= 100µA

Protective Earth Resistance <= 200mOhms

Classification - Continuous mode of operation, Portable Equipment

AC Power Supply -

100 - 230 VAC, 50 - 60Hz, 60VA (Maximum).

Fuse Type -

2 X T 1.25 A, slow blowing.

Dimensions -

148mm (w) x 225mm (h) x 148mm (d). Weight: approx. 2.5kg (excluding power cable).

Protection against fluid ingress -

IPX3 - Protected against spraying water.

Environmental Specifications

Condition	Operating	Transport & Storage
Temperature	+5°C - +40°C	-20°C - +50°C
Humidity	20% - 90%*	15% - 95%*
Atmospheric Pressure	700hPa - 1060 hPa	500hPa - 1060hPa

*Non condensing.

BATTERY SPECIFICATIONS -

Rechargeable NiMH (Nickel Metal Hydride). Automatically charges when the pump is connected to AC power.

Battery Life - For a 24 hour battery charge time, the pump at 25ml/h will have a Mean Time To Battery Empty of 6 hours.

Battery Charging - 2.5 hours to 95%.

Alarm Conditions -

Warnings	Alarms
AC POWER FAIL VTBI DONE BATTERY LOW AIR-IN-LINE TITRATION SET CLOCK RATE LOCK LOG FAILURE SET SERIAL NUMBER	AIR IN LINE (SINGLE BUBBLE) AIR IN LINE (ACCUMULATED) DOOR OPEN DOWNSTREAM OCCLUSION UPSTREAM OCCLUSION NO FLOW FLOW ERROR FREE FLOW BATTERY EMPTY SAFETY CLAMP
Prompts	SET MISLOAD FLOW SENSOR DISCONNECTED WRONG SET DOOR CLOSE INCOMPLETE DO NOT USE LEVER OPEN
ATTENTION SET VTBI SET NOT FITTED LOCKED	
Advisories	
DOSE WOULD EXCEED DOSE UNDER DOSE NOT PERMITTED RATE NOT PERMITTED WEIGHT ABOVE LIMIT WEIGHT BELOW LIMIT CONCENTRATION NOT PERMITTED	

Memory Retention -

The electronic memory of the pump will be retained for more than 2 years with normal use.

IrDA / RS232 / Nursecall Feature

The IrDA (or RS232 / Nursecall optional feature) is a feature on Alaris® GP Guardrails® Volumetric Pump that allows the pump to be connected to an external device for the purpose of data communication



The nursecall interface provides a remote backup to the internal audible alarm. It should not be relied upon to replace monitoring of the internal alarm. Refer to the Technical Service Manual for further information regarding the RS232 interface. The assessment for the suitability of any software used in the clinical environment to control receive data from the pump lies with the user of the equipment. This software should include detection of the disconnection or other failure of the RS232 cable.

Any connected analogue and digital components are required to meet IEC/EN60950 for data processing and IEC/EN60601 for medical devices. Anyone connecting additional devices to the signal input or output is a system configurator and responsible for meeting the requirements of the system standard IEC/EN60601-1-1. To connect to the RS232 port use spare part 1000SP01183 - RS232 cable.

RS232 / Nursecall Connection Data

Nursecall Specification -

Connector	D Type - 9 Pin
TXD/RXD	EIA RS232-C Standard
Baud Rate	115k Baud
Start Bits	1 Start Bit
Data Bits	8 Data Bits
Parity	No Parity
Stop Bits	1 Stop Bit
Nurse Call Relay Contacts	Pins 1, 8 + 9, 30V dc, 1A rating

Typical Connection Data -

- 1 Nursecall (Relay) Normally Closed
- 2 Transmit Data (TXD) Output
- 3 Received Data (RXD) Input
- 4 DTR → DSR (6)
- 5 Ground (GND)
- 6 DSR → DTR (4)
- 7 Not used
- 8 Nursecall (Relay) Normally Open
- 9 Nursecall (Relay) Common

IrDA

Baud Rate	115k Baud
Start Bits	1 Start Bit
Data Bits	8 Data Bits
Parity	No Parity
Stop Bits	1 Stop Bit

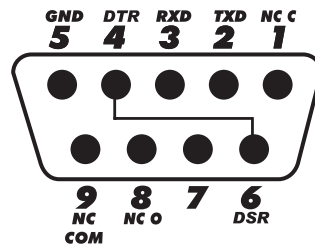

Infusion Specifications

System Accuracy:

Rate Accuracy is $\pm 5\%$, achieved under nominal conditions^{1a,2}

Rate Accuracy is $\pm 10\%$, achieved under low flow conditions^{1b,2}

Occlusion Alarm Limits

Achieved under nominal conditions^{1a,4}

Level	L2 - Low	L5 - Medium	L8 - High ≤ 200 ml/h	L8 - High > 200 ml/h
Pressure (mmHg) approx.	230	460	725	950

Maximum Occlusion Alarm Pressure: 1250 mmHg

Post Occlusion Bolus:

Bolus volume generated at 25 ml/h when the minimum occlusion alarm threshold is reached <0.45 ml

Bolus volume generated at 25 ml/h when the maximum occlusion alarm threshold is reached <0.95 ml

Bolus Volume Accuracy:

Typical: -4.1%, Max: -3.2%, Min: -5.5% 1ml @ 10ml/h

Typical: -1.3%, Max: -0.9%, Min: -1.6% 100ml @ 1200ml/h

Administering a Bolus

Parameter	Range
Bolus Rate	10 - 1200ml/h in steps of 10ml/h
Bolus Volume Displayed	0.0ml - 100.0ml in steps of 0.1ml

Starting the Infusion / Set-up

Infusion Parameter	Range
Infusion Rate	0.1 - 99.9ml/h in steps of 0.1ml/h & 100 - 999ml/h in steps of 1ml/h 1000 - 1200ml/h in steps of 10ml/h
VTBI Primary	(0 - OFF), 1 - 9999ml
VI (Total)	0.1 - 9999ml

Maximum time for activation of occlusion alarm:

At Maximum Pressure, time to alarm at 0.1ml/h is nominally 735 [±50] minutes (Maximum <883 min)

At Minimum Pressure, time to alarm at 0.1ml/h is nominally 234 [±25] minutes (Maximum <309 min)

At Maximum Pressure, time to alarm at 1.0ml/h is nominally 65 [±4] minutes (Maximum <95 min)

At Minimum Pressure, time to alarm at 1.0ml/h is nominally 16 [±2] minutes (Maximum <28 min)

At Maximum Pressure, time to alarm at 25ml/h is nominally 119 [±7] seconds (Maximum <3 min)

At Minimum Pressure, time to alarm at 25ml/h is nominally 29 [±3] seconds (Maximum <50 sec)

Air Sensor:

Integral Ultrasonic Sensor.

Air in line detection:

Single Bubble (configurable): 50µl, 100µl, 250µl & 500µl.

Bubble accumulation: 1ml over a 15 minute window.

Critical Volume

The maximum volume infused following a single fault condition is for rates < 10ml/h: +/- 0.25 ml, rates < 100ml/h: +/- 0.5ml, rates ≥100ml/h: +/- 2 ml

Set based, pump activated Safety Clamp Device to prevent free flow

Notes:

- 1a. Nominal conditions are defined as:
Set Rate: 1 to 1200 ml/h;
Recommended disposable: 60593;
Needle: 18 gauge x 40 mm;
Solution Type: De-ionized & Degassed Water;
Temperature: 23°C ± 2°C
Fluid Head Height: +300 ± 30 mm;
Back Pressure: 0 ± 10 mmHg.
- 1b. Low flow conditions are defined as:
Set Rate: less than 1.0ml/h
Recommended disposable: 60593;
Needle: 18 gauge x 40 mm;
Solution Type: De-ionized & Degassed Water;
Temperature: 23°C ± 2°C
Fluid Head Height: +300 ± 30 mm;
Back Pressure: 0 ± 10 mmHg.
2. The system accuracy will change by the following percentages:³
Temperature: nominally -5.7 (±1.5)% at 5 °C and nominally +0.3 (±1.7)% at 40 °C
Fluid Head Height: nominally -3.4 (±1.3)% at -0.5 m and 0.0 (±1.1)% at +0.5 m
Duration: nominally -1.1 [±0.2] % over 24 hours of continuous use
Back Pressure: nominally +2.0 (±1.3)% at -100 mmHg, -13.4 (±1.8)% at +800 mmHg respectively
Atmospheric pressure: ± 5% at 25ml/h at 700hPa
3. Tested using Distilled water, 20% lipid, 50% glucose, 0.9% Normal Saline and 5% Alcohol solutions.
4. The occlusion pressure accuracy will change by the following:
Temperature: Low setting nominally 7 (±12) mmHg at 5 °C and -24 (±17) mmHg at 40 °C respectively
Normal setting nominally 4 (±16) mmHg at 5 °C and -41 (±18) mmHg at 40 °C respectively
High Pressure nominally 4 (±14) mmHg at 5 °C and -38 (±21) mmHg at 40 °C respectively



The specified accuracy may not be maintained if the above conditions are not met, see notes 1 to 4.

Trumpet & Flow Rate Curves

In this pump, as with all infusion systems, the action of the pumping mechanism and variations cause short-term fluctuations in rate accuracy.

The following curves show typical performance of the system in two ways: 1) the accuracy of fluid delivery over various time periods is measured (trumpet curves), and 2) the delay in onset of fluid flow when infusion commences (start-up curves).

Trumpet curves are named for their characteristic shape. They display discrete data averaged over particular time periods or 'observation windows,' not continuous data versus operating time. Over long observation windows, short term fluctuations have little effect on accuracy as represented by the flat part of the curve. As the observation window is reduced, short term fluctuations have greater effects as represented by the "mouth" of the trumpet.

Knowledge of system accuracy over various observation windows may be of interest when certain drugs are being administered. Short term fluctuations in rate accuracy may have clinical impact depending on the half-life of the drug being infused and the degree of inter vascular integration, the clinical effect cannot be determined from the trumpet curves alone.

The start-up curves represent continuous flow versus operating time for two hours from the start of the infusion. They exhibit the delay in onset of delivery due to mechanical compliance and provide a visual representation of uniformity. Trumpet curves are derived from the second hour of this data. Tests performed per IEC/EN60601-2-24 standard.

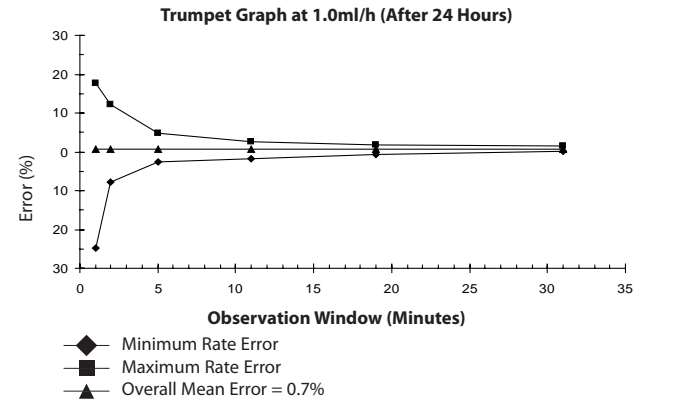
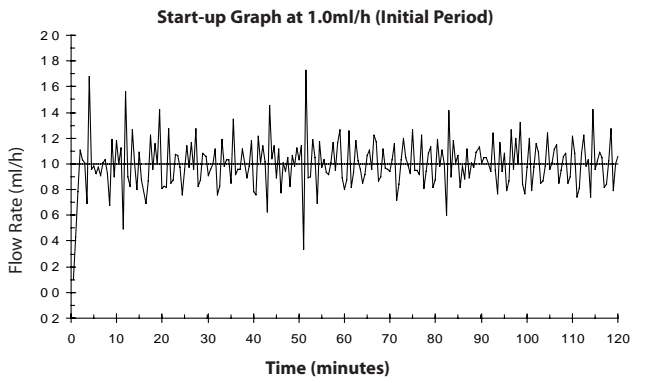
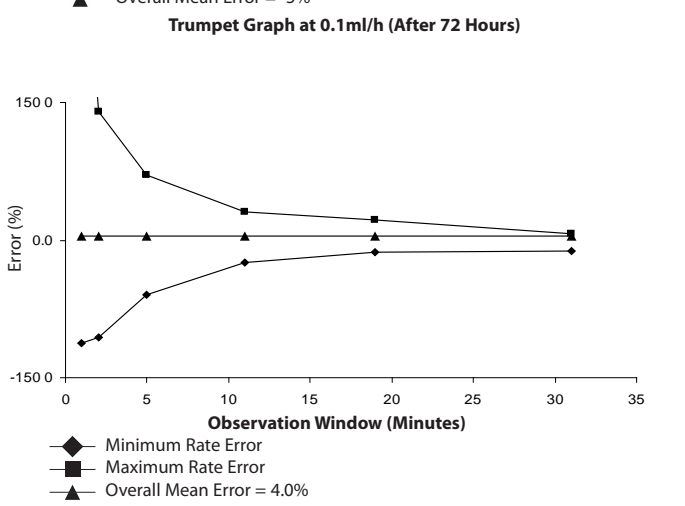
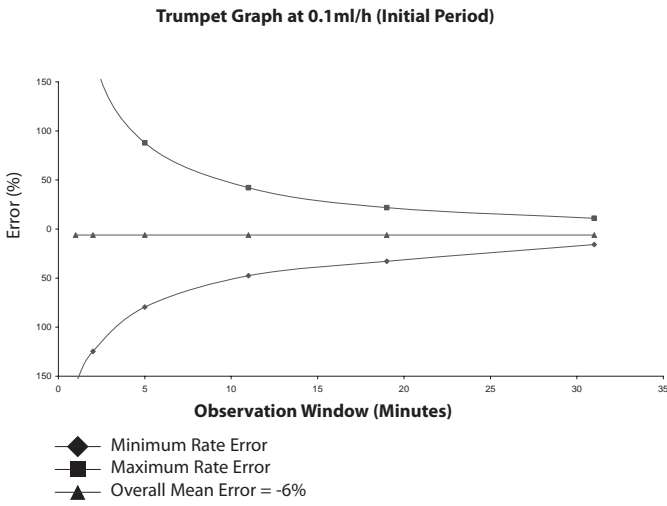
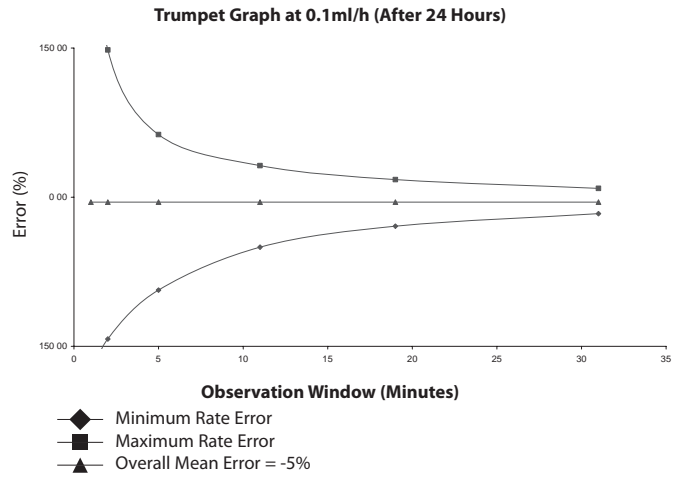
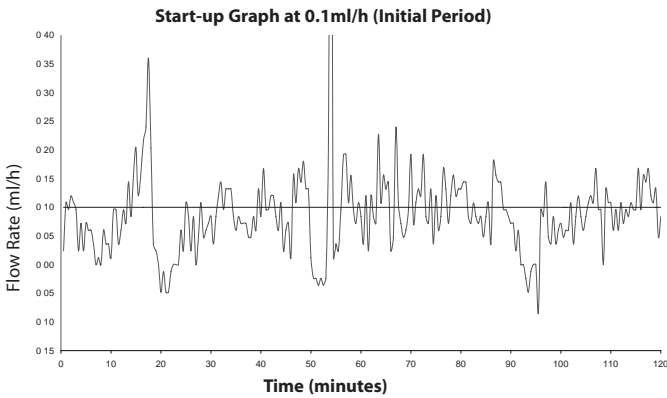

Note: The typical flow rate and trumpet curves are achieved using a recommended infusion set. The plot range has been increased to $\pm 150\%$, to allow visualization of the graph.

Trumpet & Flow Rate Curves (Continued)

Trumpet Graph at 1.0ml/h (Initial Period)

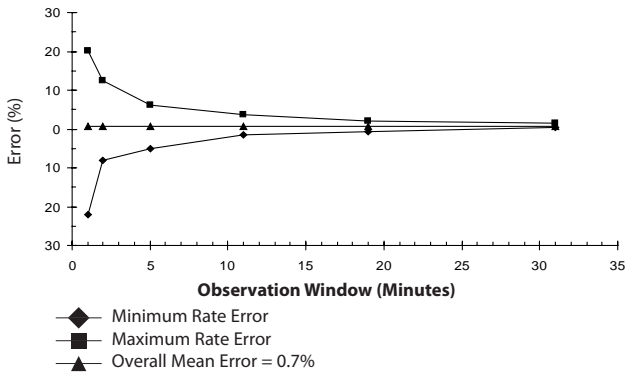

Trumpet Graph at 1.0ml/h (After 72 Hours)

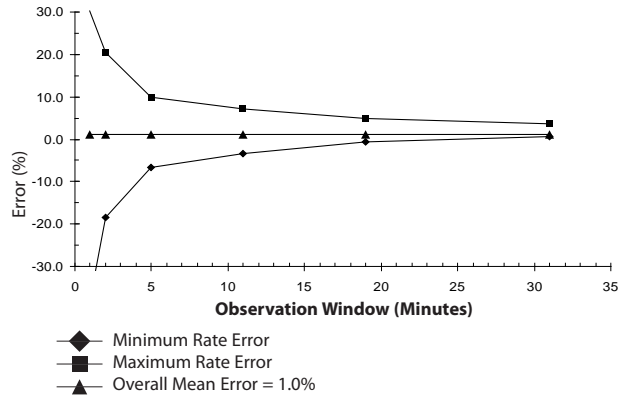

Start-up Graph at 25.0ml/h (Initial Period)

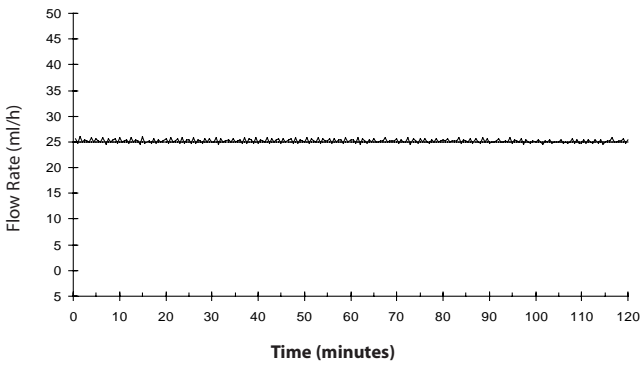

Trumpet Graph at 25.0ml/h (After 24 Hours)

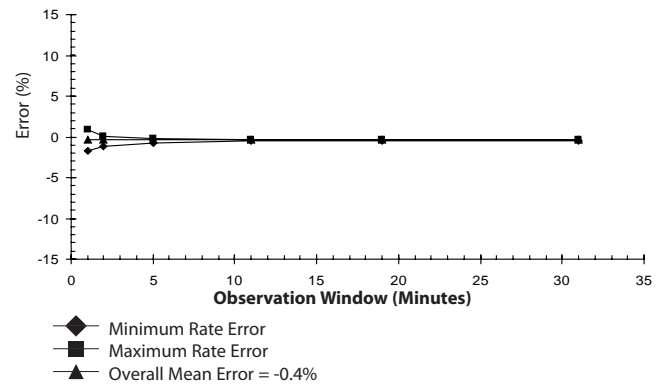

Trumpet Graph at 25.0ml/h (Initial Period)

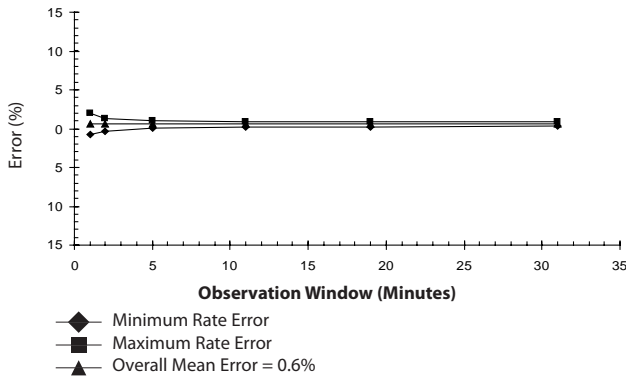

Trumpet Graph at 25ml/h (After 72 Hours)

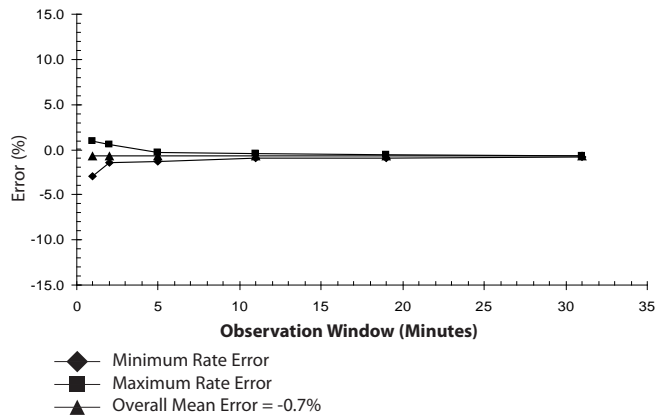

Note: The typical flow rate and trumpet curves are achieved using a recommended infusion set.

Alaris® Infusion System

Range of products in the Alaris® Infusion System product family are:

Part Number	Description
80013UN01	Alaris® GS Syringe Pump
80023UN01	Alaris® GH Syringe Pump
80033UND1	Alaris® CC Syringe Pump
80043UN01	Alaris® TIVA Syringe Pump
80053UN01	Alaris® PK Syringe Pump
80263UN01-G	Alaris® GP Guardrails® Volumetric Pump
80033UND1-G	Alaris® CC Guardrails® Syringe Pump
80023UN01-G	Alaris® GH Guardrails® Syringe Pump
80083UN00-xx*	Alaris® DS Docking Station
80203UNS0x-xx*	Alaris® Gateway Workstation

* For Docking Stations and Workstation contact local customer services representative to obtain configurations availability and part numbers.

Spare Parts

A comprehensive list of spare parts for this pump is included within the Technical Service Manual.

The Technical Service Manual (1000SM00013) is now available in electronic format on the World Wide Web at :-

www.carefusion.com/alaris-intl/

A username and password are required to access our manuals. Please contact a local customer services representative to obtain login details.

Part Number	Description
1000SP00487	Internal Battery Pack
1000SP01183	RS232 Cable
1001FAOPT91	AC Power Lead - UK
1001FAOPT92	AC Power Lead - European

Guardrails® Editor Software

Part Number	Description
1000SP01389	Guardrails® Editor v3.1 - Data Set Editor and Transfer Tool Software Kit
1000SP01390	Guardrails® Editor v3.1 - Transfer Tool Software Kit

Service Contacts

For service contact your local Affiliate Office or Distributor:

AE

CareFusion,
PO Box 5527,
Dubai, United Arab Emirates.

Tel: (971) 4 28 22 842

Fax: (971) 4 28 22 914

AU

CareFusion,
3/167 Prospect Highway,
PO Box 355
Seven Hills, NSW 2147,
Australia.

Tel: (61) 2 9838 0255

Fax: (61) 2 9674 4444

BE

CareFusion,
Leuvensesteenweg 248 D,
1800 Vilvoorde,
Belgium.

Tel: (32) 2 267 38 99

Fax: (32) 2 267 99 21

CA

CareFusion,
235 Shields Court,
Markham,
Ontario L3R 8V2,
Canada.

Tel: (1) 905-752-3333

Fax: (1) 905-752-3343

CH

CareFusion Switzerland 221
Sàrl
Critical Care
A-One Business Centre
Zone d'activités Vers-la-Pièce
n° 10
1180 Rolle / Switzerland

Ph.: 0848 244 433

Fax: 0848 244 100

CN

CareFusion,
Shanghai Representative Office, Suite
A, Floor 24,
Shanghai Times Square Office Building,
No.500 Zhangyang Road,
Shanghai 200122, China.

Tel: (86) 21 58368028

Fax: (86) 21 58368017

DE

CareFusion,
Pascalstr. 2,
52499 Baesweiler,
Deutschland.

Tel: (49) 2401 604 0

Fax: (49) 2401 604 121

DK

CareFusion,
Firskovvej 25 B,
2800 Lyngby,
Danmark.

Tlf. (45)70 20 30 74

Fax: (45)70 20 30 98

ES

CareFusion,
Edificio Veganova,
Avenida de La Vega, nº1,
Bloque 1 - Planta 1,
28108 Alcobendas, Madrid,
España.

Tel: (34) 902 555 660

Fax: (34) 902 555 661

FR

CareFusion,
Parc d'affaire le Val Saint Quentin
2, rue René Caudron
78960 Voisins le Bretonneux
France

Tél: (33) 1 30 05 34 00

Fax: (33) 1 30 05 34 43

GB

CareFusion,
The Crescent, Jays Close,
Basingstoke,
Hampshire, RG22 4BS,
United Kingdom.

Tel: (44) 0800 917 8776

Fax: (44) 1256 330860

HU

CareFusion,
Döbrentei tér 1,
H-1013 Budapest,
Magyarország.

Tel: (36) 14 88 0232

Tel: (36) 14 88 0233

Fax: (36) 12 01 5987

IT

CareFusion,
Via Ticino 4,
50019 Sesto Fiorentino,
Firenze, Italia.

Tél: (39) 055 30 33 93 00

Fax: (39) 055 34 00 24

NL

CareFusion,
De Molen 8-10,
3994 DB Houten,
Nederland.

Tel: (31) 30 228 97 11

Fax: (31) 30 225 86 58

NO

CareFusion,
Solbråveien 10 A,
1383 ASKER,
Norge.

Tel: (47) 66 98 76 00

Fax: (47) 66 98 76 01

NZ

CareFusion,
14B George Bourke Drive,
Mt Wellington 1060,
PO Box 14-518,
Panmure 1741, Auckland,
New Zealand

Tel: 09 270 2420

Freephone: 0508 422734

Fax: 09 270 6285

SE

CareFusion,
Hammarbacken 4B,
191 46 Sollentuna,
Sverige.

Tel: (46) 8 544 43 200

Fax: (46) 8 544 43 225

US

CareFusion,
10020 Pacific Mesa Blvd.,
San Diego, CA 92121,
USA.

Tel: (1) 800 854 7128

Fax: (1) 858 458 6179

ZA

CareFusion,
Unit 2 Oude Molen Business Park,
Oude Molen Road, Ndabeni,
Cape Town 7405, South Africa.

Tel: (27) (0) 860 597 572

Tel: (27) 21 510 7562

Fax: (27) 21 5107567

Document History

Revision	CO Number	Date
1	9685	November 2009

Alaris, Asena, Guardrails, IVAC and SmartSite are registered trademarks of CareFusion Corporation or one of its subsidiaries. All rights reserved. All other trademarks are property of their respective owners.

©2008-2010 CareFusion Corporation or one of its subsidiaries. All rights reserved.

This document contains proprietary information of CareFusion Corporation or one of its subsidiaries, and its receipt or possession does not convey any rights to reproduce its contents, or to manufacture or sell any product described. Reproduction, disclosure, or use other than for the intended purpose without specific written authorization of CareFusion Corporation or one of its subsidiaries is strictly forbidden.



CareFusion Switzerland 317 Sàrl,
CH-1180, Rolle



CareFusion U.K. 305 Ltd., RG22 4BS, UK

1000DF00498 Issue 1