

Agilent 1260 Infinity Quaternary LC VL

System Manual and
Quick Reference



Agilent Technologies

Notices

© Agilent Technologies, Inc. 2010

No part of this manual may be reproduced in any form or by any means (including electronic storage and retrieval or translation into a foreign language) without prior agreement and written consent from Agilent Technologies, Inc. as governed by United States and international copyright laws.

Manual Part Number

G1311-90310

Edition

06/2010

Printed in Germany

Agilent Technologies
Hewlett-Packard-Strasse 8
76337 Waldbronn

This product may be used as a component of an in vitro diagnostic system if the system is registered with the appropriate authorities and complies with the relevant regulations. Otherwise, it is intended only for general laboratory use.

Warranty

The material contained in this document is provided “as is,” and is subject to being changed, without notice, in future editions. Further, to the maximum extent permitted by applicable law, Agilent disclaims all warranties, either express or implied, with regard to this manual and any information contained herein, including but not limited to the implied warranties of merchantability and fitness for a particular purpose. Agilent shall not be liable for errors or for incidental or consequential damages in connection with the furnishing, use, or performance of this document or of any information contained herein. Should Agilent and the user have a separate written agreement with warranty terms covering the material in this document that conflict with these terms, the warranty terms in the separate agreement shall control.

Technology Licenses

The hardware and/or software described in this document are furnished under a license and may be used or copied only in accordance with the terms of such license.

Restricted Rights Legend

If software is for use in the performance of a U.S. Government prime contract or subcontract, Software is delivered and licensed as “Commercial computer software” as defined in DFAR 252.227-7014 (June 1995), or as a “commercial item” as defined in FAR 2.101(a) or as “Restricted computer software” as defined in FAR 52.227-19 (June 1987) or any equivalent agency regulation or contract clause. Use, duplication or disclosure of Software is subject to Agilent Technologies’ standard commercial license terms, and non-DOD Departments and Agencies of the U.S. Government will

receive no greater than Restricted Rights as defined in FAR 52.227-19(c)(1-2) (June 1987). U.S. Government users will receive no greater than Limited Rights as defined in FAR 52.227-14 (June 1987) or DFAR 252.227-7015 (b)(2) (November 1995), as applicable in any technical data.

Safety Notices

CAUTION

A **CAUTION** notice denotes a hazard. It calls attention to an operating procedure, practice, or the like that, if not correctly performed or adhered to, could result in damage to the product or loss of important data. Do not proceed beyond a **CAUTION** notice until the indicated conditions are fully understood and met.

WARNING

A **WARNING** notice denotes a hazard. It calls attention to an operating procedure, practice, or the like that, if not correctly performed or adhered to, could result in personal injury or death. Do not proceed beyond a **WARNING** notice until the indicated conditions are fully understood and met.

In This Book

This book describes the Agilent 1260 Infinity Quaternary LC VL

1 Introduction

This chapter gives an introduction to the Agilent 1260 Infinity Quaternary LC VL, the underlying concepts and the features of the Agilent 1260 Infinity Quaternary LC VL.

2 Specifications

This chapter provides information about specifications for the LC system.

3 Optimization of the Agilent 1260 Infinity Quaternary LC VL

This chapter considers how to apply the theory and use the features of the LC system to develop optimized separations.

4 System Setup and Installation

This chapter includes information on software installation, stack configurations and preparing the system for operation.

5 Quick Start Guide

This chapter provides information on data acquisition and data analysis with the Agilent 1260 Infinity Quaternary LC VL.

6 Appendix

This chapter provides addition information on safety, legal, web and the Edit Entire Method.

Contents

1	Introduction	7
	Introduction to the Agilent 1260 Infinity Quaternary LC VL	8
	Features of the Agilent 1260 Infinity Quaternary LC VL	10
	System Components	11
	Optimizing the Stack Configuration	12
	Quaternary pump	17
	Autosampler	19
	Thermostatted column compartment	24
	Detector	25
2	Specifications	37
	Physical Specifications	38
	Performance Specifications	40
3	Optimization of the Agilent 1260 Infinity Quaternary LC VL	49
	Optimizing the Pump	50
	Optimizing the Autosampler	54
	Optimizing the Thermostatted Column Compartment	61
	Optimizing the Detector Regarding to the System	62
	Optimizing Detection with DAD	63
	Optimizing Detection with VWD	78
4	System Setup and Installation	83
	Installing Software	84
	Installing the Modules	85
5	Quick Start Guide	91
	Preparing the System	92
	Setting Up the Method	97

6 Appendix 99

Safety 100

The Waste Electrical and Electronic Equipment Directive 103

Lithium Batteries Information 104

Radio Interference 105

Sound Emission 106

Solvent Information 107

UV-Radiation 108

Declaration of Conformity for HOX2 Filter 109

Agilent Technologies on Internet 110

Contents

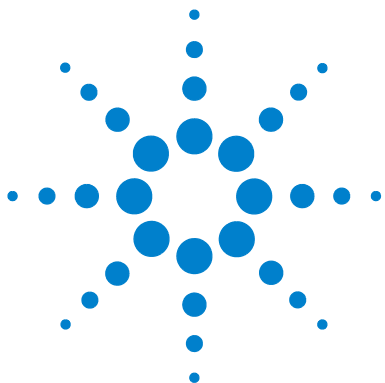

1 Introduction

Introduction to the Agilent 1260 Infinity Quaternary LC VL	8
Concept of the Quaternary LC VL System	8
System Properties	8
Features of the Agilent 1260 Infinity Quaternary LC VL	10
System Components	11
Optimizing the Stack Configuration	12
One Stack Configuration	12
Two Stack Configuration	15
Quaternary pump	17
Hydraulic Path	18
Autosampler	19
Sequences	21
Thermostatted column compartment	24
Detector	25
Diode-Array Detector (DAD)	25
Variable Wavelength Detector (VWD)	30

This chapter gives an introduction to the Agilent 1260 Infinity Quaternary LC VL, the underlying concepts and the features of the Agilent 1260 Infinity Quaternary LC VL.



Introduction to the Agilent 1260 Infinity Quaternary LC VL

Concept of the Quaternary LC VL System

The Agilent 1260 Infinity Quaternary LC VL offers the most flexibility for solvent selection and automation in HPLC method development, research and all HPLC applications requiring continuous access to a wide range of solvent choices. The availability to rapidly switch between methods using different solvents and the capability of using binary, ternary or quaternary solvent gradients make the Agilent 1260 Infinity Quaternary LC VL the most flexible system on the market.

System Properties

The Agilent 1260 Infinity Quaternary LC VL is ideally suited for multi-method, high-throughput workflows. It offers:

- Convenient access to four solvents for isocratic or gradient analysis for rapid method development and speed up preparation of mobile phases and flushing the HPLC system.
- Pressure range up to 400 bar.
- A wide flow range up to 10 mL/min and a delay volume of 800 – 1100 μ L supports narrow-bore, standard and semi-preparative applications.
- Easy programming and control through the Instant Pilot G4208A (requires firmware B.02.08 or above) (p/n G4208-67001) or through an Agilent Data System.
- Included micro vacuum degasser offers high degassing efficiency for trouble-free operation and highest performance and completely eliminates the need for helium sparging.
- Direct front access for quick exchange of maintenance parts.
- Fast problem identification by self-diagnostics, built-in log books and preprogrammed test methods.

- Early maintenance feedback (EMF) that continuously tracks long-term instrument usage and user-defined limits with feedback message when limit is exceeded.
- Upgradeability and expandability with the complete range of Agilent 1200 Infinity Series HPLC modules.
- Agilent Data System helps you manage your lab for best chromatographic quality with intuitive diagnostic and monitor capabilities and alert functions to notify you of problems.

Features of the Agilent 1260 Infinity Quaternary LC VL

The Agilent 1260 Infinity Quaternary LC VL is designed to offer the greatest flexibility for performing analytical liquid chromatography using all types of current and emergent column technologies.

The quaternary system as described in this manual offers:

- Gradients of up to 4 different solvents.
- Pressure range up to 400 bar.
- Sophisticated pump control to deliver very low chromatographic noise and very low acoustic noise for better results and better working environment.
- Degasser and automatic purge valve integrated into pump module.
- Variable volume autosampler with reduced delay volume, reduced carryover and the option to operate as a fixed loop autosampler.
- Thermostated column compartment with a pressure range up to 600 bar
- Choice of detectors (a set of different flow cells is available for different detectors to fit application needs regarding flow ranges (nano scale, micro scale, standard and preparative applications) and pressures):
 - Diode-array detector with greatly enhanced sensitivity and baseline stability using cartridge cell system with optofluidic waveguides (data collection rate up to 80 Hz with full spectral information) or
 - Variable wavelength detector.

System Components

Solvent cabinet

The solvent cabinet is a case to keep four bottles with solvent standing framed and stable, so that they can be connected by solvent tubings to the LC System.

Quaternary pump

The quaternary pump generates gradients by low pressure mixing from four individual solvent channels.

Autosampler with/without thermostat

The autosampler is specifically designed for the Agilent 1200 Infinity Series system for increased analysis speed with sensitivity, resolution, and precision.

Thermostatted column compartment

This stackable temperature-controlled column compartment is used for heating and cooling in order to meet extreme requirements of retention time reproducibility.

Diode array or variable wavelength detector

Signals triggered by UV absorption are sampled to be converted to electrical signals in order for display and software handling.

The Agilent 1260 Infinity Quaternary LC VL are described in more detail in the following sections. All modules are stackable, see [“One Stack Configuration”](#) on page 12 and [“Two Stack Configuration”](#) on page 15.

Optimizing the Stack Configuration

You can ensure optimum performance by installing the system in following configurations. These configurations optimize the system flow path, ensuring minimum delay volume.

One Stack Configuration

Ensure optimum performance by installing the modules of the Agilent 1260 Infinity LC System in the following configuration (see [Figure 1](#) on page 13 and [Figure 2](#) on page 14). This configuration optimizes the flow path for minimum delay volume and minimizes the bench space required.

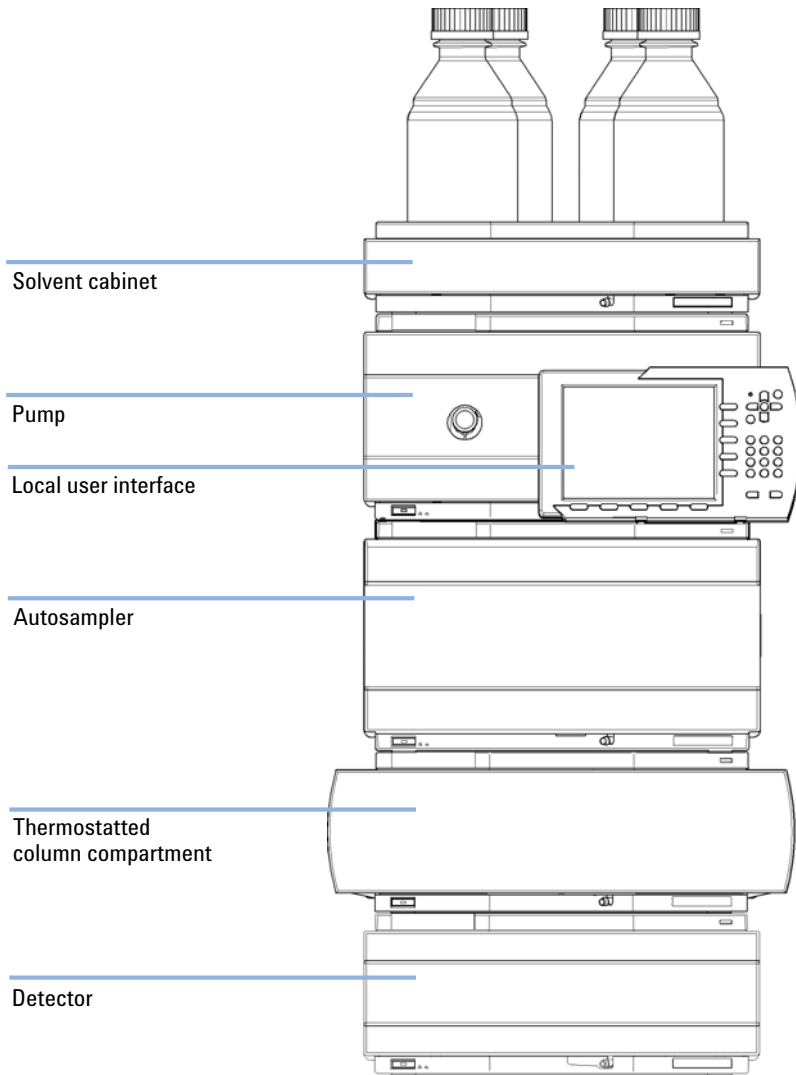

Figure 1 Recommended Stack Configuration (Front View)

1 Introduction

Optimizing the Stack Configuration

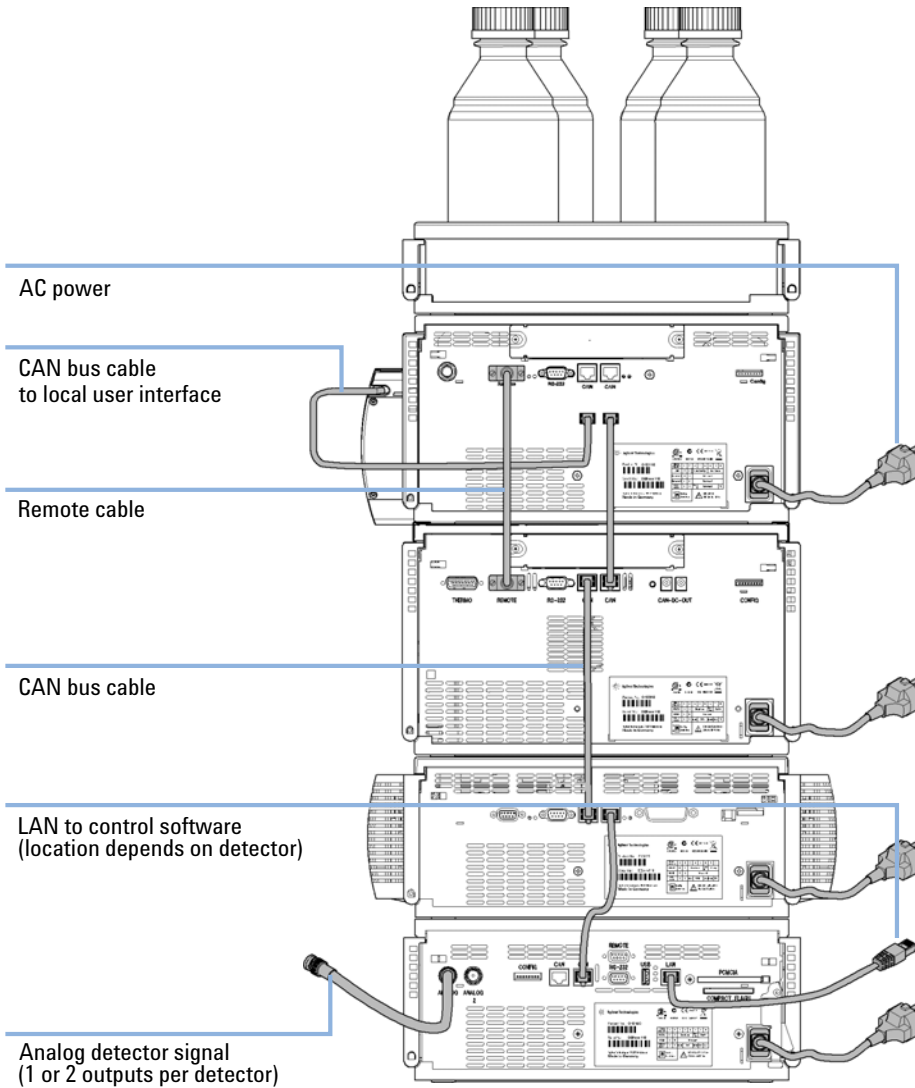

Figure 2 Recommended Stack Configuration (Rear View)

Two Stack Configuration

To avoid excessive height of the stack when the autosampler thermostat is added to the system it is recommended to form two stacks. Some users prefer the lower height of this arrangement even without the autosampler thermostat. A slightly longer capillary is required between the pump and autosampler. See [Figure 3](#) on page 15 and [Figure 4](#) on page 16.

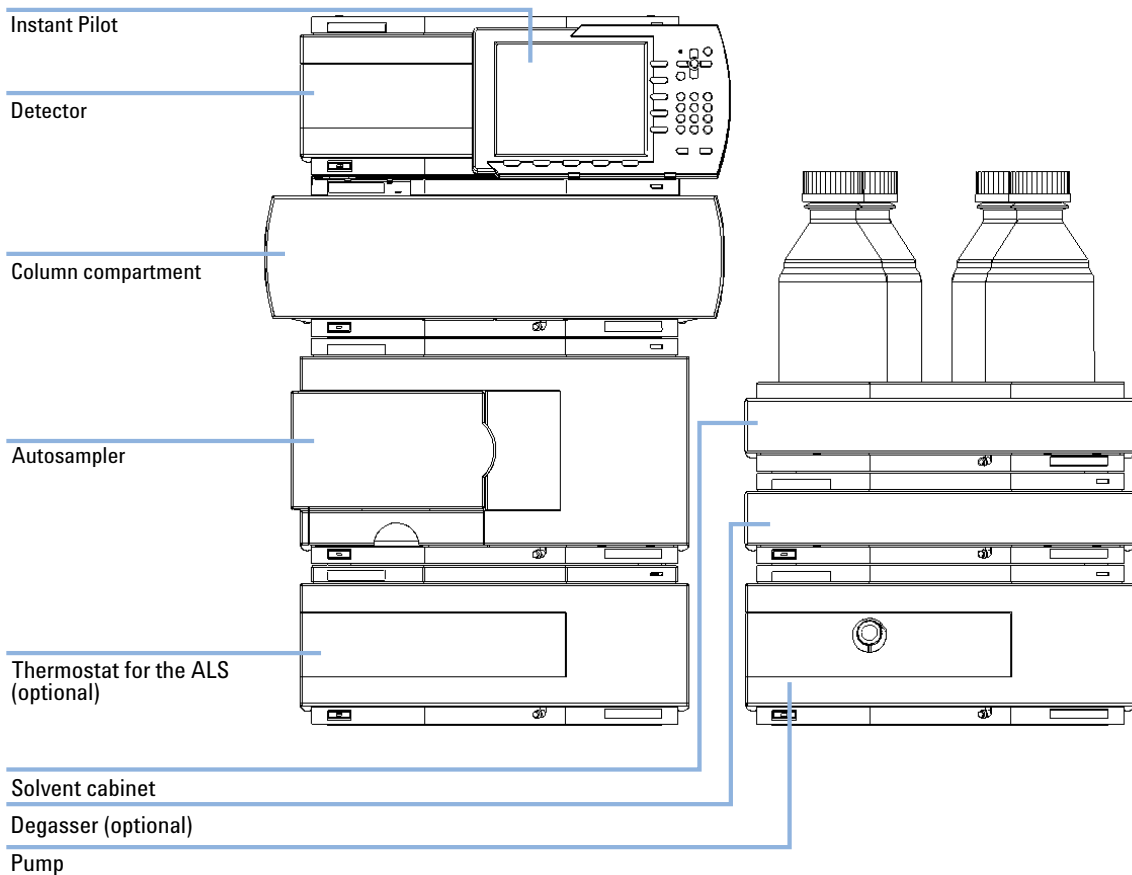

Figure 3 Two stack configuration (front view)

1 Introduction

Optimizing the Stack Configuration

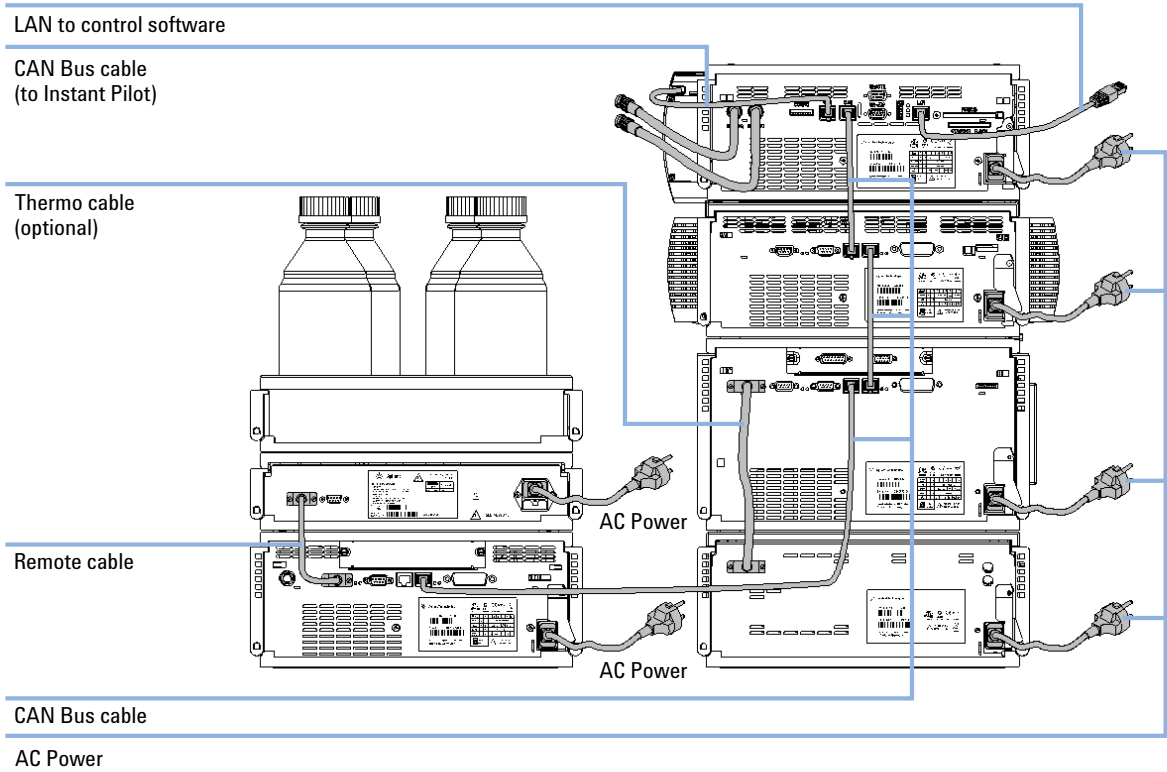

Figure 4 Two stack configuration (rear view)

Quaternary pump

The quaternary pump is based on a two-channel, dual-plunger in-series design which comprises all essential functions that a solvent delivery system has to fulfill. Metering of solvent and delivery to the high-pressure side are performed by one pump assembly which can generate pressure up to 400 bar.

Degassing of the solvents is done in a built-in vacuum degasser. Solvent compositions are generated on the low-pressure side by a high-speed proportioning valve (MCGV).

The pump assembly includes a pump head with a passive inlet valve and an outlet valve. A damping unit is connected between the two plunger chambers. A purge valve including a PTFE frit is fitted at the pump outlet for convenient priming of the pump head.

An active seal wash (optional) is available for applications using concentrated buffers as solvents.

Hydraulic Path

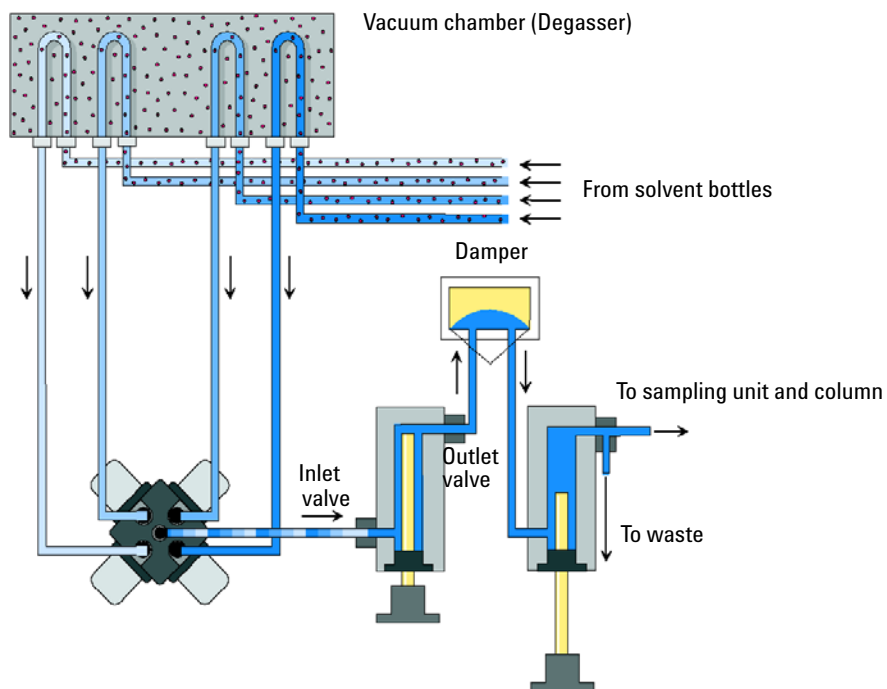

Figure 5 Hydraulic Path of the Quaternary Pump

Autosampler

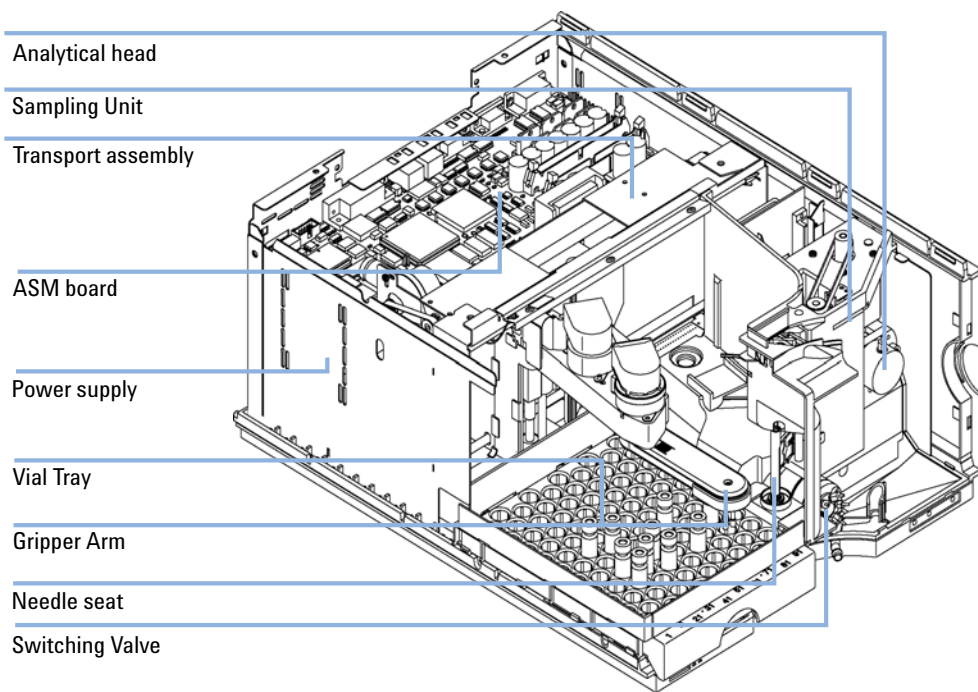

Figure 6 Overview of the Autosampler

The Agilent 1260 Infinity Autosampler is designed to offer the well-established Agilent flow-through design with variable volume injection and to achieve extremely low carryover. The small hydraulic volume of the flow path is suited to fast gradients and the ability to use overlapped injections and automatic delay volume reduction (ADVR) contribute to faster cycle times and even faster gradient delivery to the column. The system draws exactly the set volume of sample solution without waste and achieves high reproducibility across the whole range of possible injection volume. The autosampler is controlled from G4208 A Instant Pilot or from the Agilent Data System.

Three sample-rack sizes are available. The standard full-size rack holds 100 × 1.8 mL vials, while the two half-size racks provide space for 40 × 1.8 mL

vials and 15 × 6 mL vials respectively. Any two half-size rack trays can be installed in the autosamplers simultaneously. A specially designed sample-rack holding 100 × 1.8 mL vials is available for use with thermostatted autosamplers. The half-size racks trays are not designed for an optimal heat transfer when they are used with a thermostatted autosampler.

The autosamplers transport mechanism uses an X-Z-Theta movement to optimize vial pick-up and return. Vials are picked up by the gripper arm, and positioned below the sampling unit. The gripper transport mechanism and sampling unit are driven by motors. Movement is monitored by optical sensors and optical encoders to ensure correct operation. The metering device is always flushed after injection to ensure minimum carry-over.

The module uses an analytical head providing injection volumes from 0.1 to 100 µL for pressures up to 600 bar.

The six-port injection valve unit (only 5 ports are used) is driven by a high-speed hybrid stepper motor. During the sampling sequence, the valve unit bypasses the autosampler, and directly connects the flow from the pump to the column. During injection and analysis, the valve unit directs the flow through the autosampler which ensures that the sample is injected completely into the column, and that any sample residue is removed from the metering unit and needle from before the next sampling sequence begins. Different valves are available.

Control of the vial temperature in the thermostatted autosampler is achieved using the additional Agilent 1260 Infinity ALS thermostat. Details of this module are given in the Agilent 1260 Infinity Autosampler Thermostat manual.

Sequences

Sampling sequence

The movements of the autosampler components during the sampling sequence are monitored continuously by the autosampler processor. The processor defines specific time windows and mechanical ranges for each movement. If a specific step of the sampling sequence can't be completed successfully, an error message is generated.

Solvent is bypassed from the autosamplers by the injection valve during the sampling sequence. The sample vial is selected by a gripper arm from a static sample rack, or from external vial positions. The gripper arm places the sample vial below the injection needle. The required volume of sample is drawn into the sample loop by the metering device. Sample is applied to the column when the injection valve returns to the mainpass position at the end of the sampling sequence.

The sampling sequence occurs in the following order:

- 1 The injection valve switches to the bypass position.
- 2 The plunger of the metering device moves to the initialization position.
- 3 The gripper arm moves from the home position, and selects the vial. At the same time, the needle lifts out of the seat.
- 4 The gripper arm places the vial below the needle.
- 5 The needle lowers into the vial.
- 6 The metering device draws the defined sample volume.
- 7 The needle lifts out of the vial.
- 8 If the automated needle wash is selected (see [“Using the Automated Needle Wash”](#) on page 54), the gripper arm replaces the sample vial, positions the wash vial below the needle, lowers the needle into the vial, then lifts the needle out of the wash vial.
- 9 The gripper arm checks if the safety flap is in position.
- 10 The gripper arm replaces the vial, and returns to the home position. Simultaneously, the needle lowers into the seat.
- 11 The injection valve switches to the mainpass position.

Injection sequence

Before the start of the injection sequence, and during an analysis, the injection valve is in the mainpass position (Figure 7 on page 22). In this position, the mobile phase flows through the autosamplers metering device, sample loop, and needle, ensuring all parts in contact with sample are flushed during the run, thus minimizing carry-over.

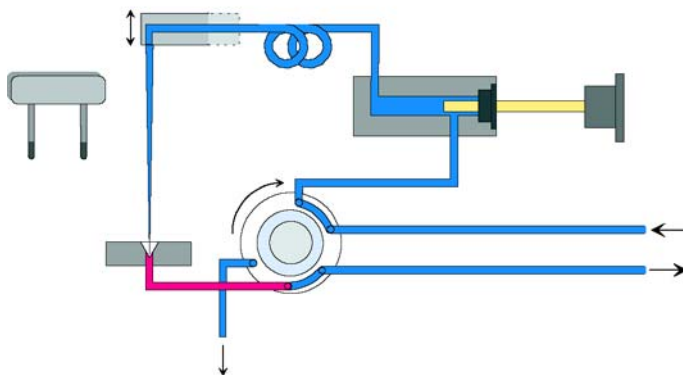

Figure 7 Mainpass Position

When the sample sequence begins, the valve unit switches to the bypass position (Figure 8 on page 22). Solvent from the pump enters the valve unit at port 1, and flows directly to the column through port 6.

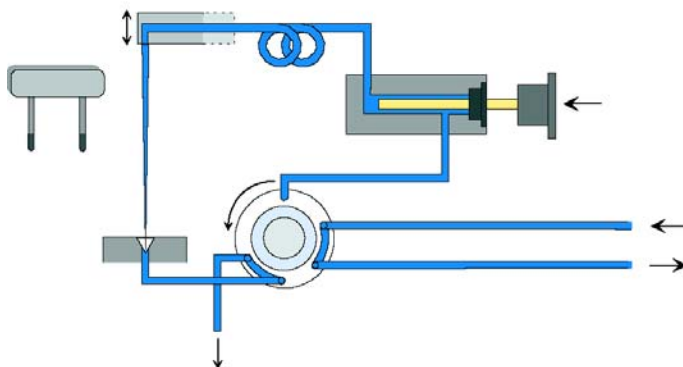

Figure 8 Bypass Position

Next, the needle is raised, and the vial is positioned below the needle. The needle moves down into the vial, and the metering unit draws the sample into the sample loop (Figure 9 on page 23).

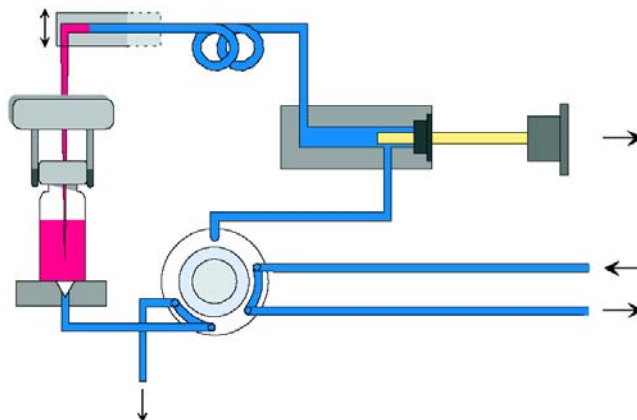

Figure 9 Drawing the Sample

When the metering unit has drawn the required volume of sample into the sample loop, the needle is raised, and the vial is replaced in the sample tray. The needle is lowered into the needle seat, and the injection valve switches back to the mainpass position, flushing the sample onto the column (Figure 10 on page 23).

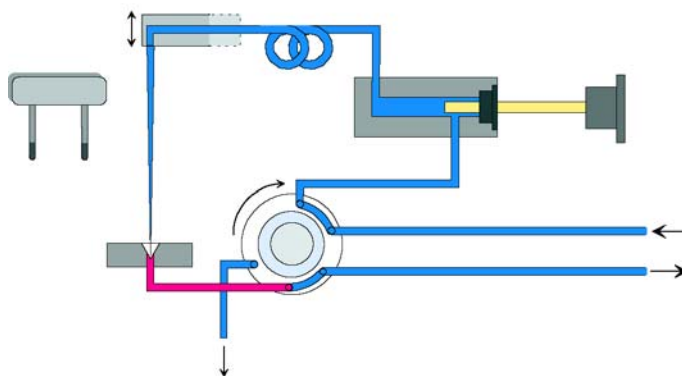

Figure 10 Mainpass Position (Sample Injection)

Thermostatted column compartment

The Agilent 1260 Infinity Thermostatted Column Compartment is a stackable temperature-controlled column compartment for LC. It is used for heating and cooling to meet extreme requirements of retention time reproducibility.

The main features are:

- Peltier heating and cooling from 10 degrees below ambient up to 80 °C with high heating and cooling speeds for maximum application flexibility and stability.
- Holds up to three 30 cm columns and optimized design gives minimum dead volumes and maximum efficiency.
- Two independently programmable heat exchangers contribute volumes of only 3 µL and 6 µL.
- Electronic column-identification module as standard for GLP documentation of column type and major column parameters.
- Optional high-quality Rheodyne® column switching valves with ceramic stator-face assemblies for prolonged lifetime.

For specifications, see [“Performance Specifications \(G1316A\)”](#) on page 41.

Detector

Diode-Array Detector (DAD)

Features (G4212B)

The detector is designed for highest optical performance, GLP compliance and easy maintenance. It includes the following features:

- Maximum of 80 Hz data acquisition rate.
- Higher sensitivity for conventional LC as well as ultra fast applications by using next generation optical design.
- Increased sensitivity with 60 mm Max-Light cartridge flow cell.
- Optimized cell geometry for less peak dispersion for narrow bore applications.
- More reliable and robust peak integration process (automated) due to less baseline noise/drift/refractive index and thermal effects especially under ultra fast gradient conditions.
- RFID tracking technology is used for the UV-lamp and the Max-Light cartridge flow cells.
- Multiple wavelength and full spectral detection at 80 Hz sampling rate, keeping up with the analysis speed of ultra-fast LC.
- Fixed 4 nm slit for rapid optimization of sensitivity, linearity and spectral resolution provides optimum incident light conditions .
- Improved Electronic temperature control (ETC) provides maximum baseline stability and practical sensitivity under fluctuating ambient temperature and humidity conditions.
- Additional diagnostic signals for temperature and lamp voltage monitoring.
- Easy exchange of flow cell by cartridge design.

For specifications, see “[Performance Specifications \(G4212B\)](#)” on page 43.

Optical System

The optical system of the detector is shown in [Figure 11](#) on page 26

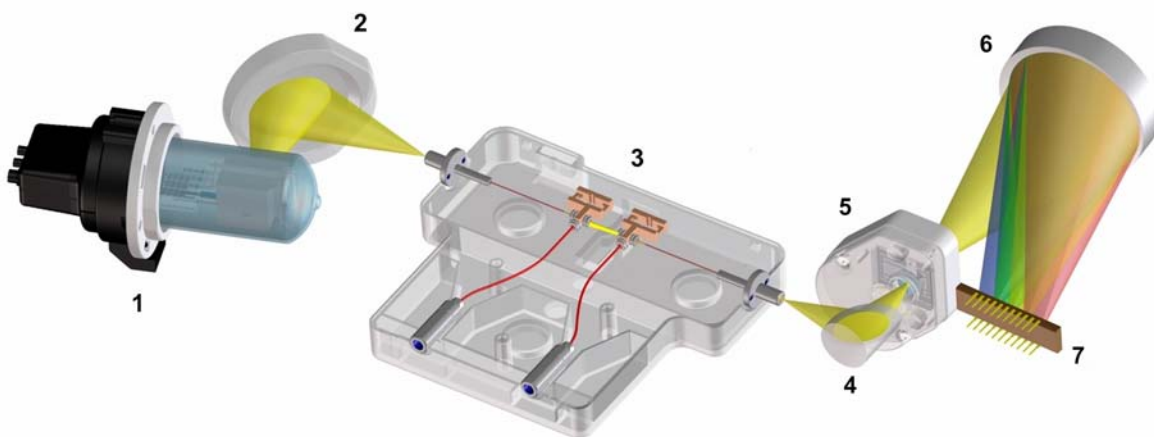

Figure 11 Optical System of the Detector

1	UV-lamp
2	Lamp mirror
3	Flow cell
4	Fold mirror
5	Micro slit
6	Grating
7	Array

The illumination source is a deuterium-arc-discharge lamp [1] for the ultraviolet (UV) wavelength range. Its light is focused by a lamp mirror [2] onto the entrance of the Max-light cartridge flow cell [3] with optofluidic waveguides. The light leaves the Max-light cartridge flow cell at the other side and is focused by the fold mirror [4] through the slit assembly [5] onto a holographic grating [6] light being dispersed onto the diode array [7]. This allows simultaneous access to all wavelength information.

Lamp

The light source for the UV-wavelength range is a long-life UV-lamp with RFID tag. As a result of plasma discharge in low-pressure deuterium gas, the lamp emits light over the 190 nm to approximately 800 nm wavelength range.

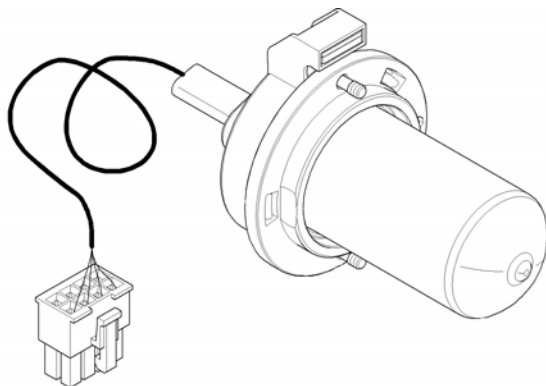

Figure 12 UV-Lamp

Max-Light Cartridge Flow Cell

The detector allows easy access to flow cells via a cartridge. A variety of optional flow cells can be inserted using the same quick, simple mounting system. A Max-Light Cartridge Cell (10 mm, $V(\sigma)$ 1.0 μL) and a Max-Light Cartridge Cell (60 mm, $V(\sigma)$ 4 μL) are available. For testing of the detector, a Max-Light Cartridge Test Cell is available.

The optical principle of the Max-Light Cartridge cell is based on opto-fluidic waveguides. Nearly 100 % light transmission is achieved by utilizing total internal reflection in a non-coated silica fiber. Compromising refractive index and thermal effects are almost completely eliminated, resulting in significantly less baseline drift.

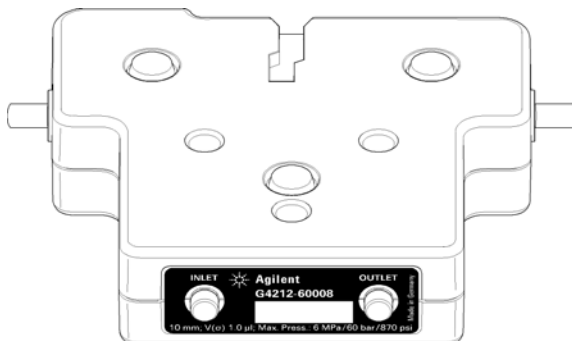

Figure 13 Max-Light Cartridge Flow Cell

Slit

The fixed slit combines the required optical functions - slit and shutter - in a simple and compact component. The slit width is directly controlled by the micro-processor of the instrument and is fixed to 4 nm.

Grating and Diode Array

The combination of dispersion and spectral imaging is accomplished by using a concave holographic grating. The grating separates the light beam into all its component wavelengths and reflects the light onto the photodiode array.

The diode array is a series of 1024 individual photodiodes and control circuits located on a ceramic carrier. It has a wavelength range from 190 – 640 nm and the sampling interval is 0.5 nm.

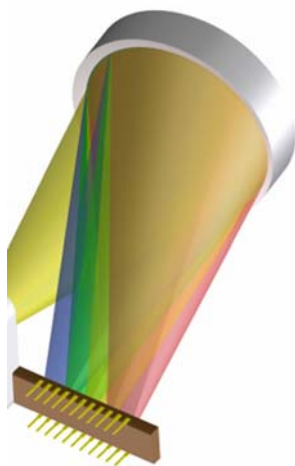

Figure 14 Grating and diode array

Variable Wavelength Detector (VWD)

Features (G1314F)

The Agilent variable wavelength detectors described in this manual is designed for highest optical performance, GLP compliance and easy maintenance with:

- data rate up to 80 Hz for standard-HPLC
- deuterium lamp for highest intensity and lowest detection limit over a wavelength range of 190 to 600 nm,
- optional flow-cell cartridges (standard 10 mm, 14 μ L; high pressure 10 mm, 14 μ L; micro 3 mm, 2 μ L; semi-micro 6 mm, 5 μ L) are available and can be used depending on the application needs (other types may be introduced later),
- easy front access to lamp and flow cell for fast replacement,
- electronic identification of flow cell and lamp with RFID (Radio Frequency Identification) tag for unambiguous identification,
 - lamp information: part number, serial number, production date, ignitions, burn time
 - cell information: part number, serial number, production date, nominal path length, volume, maximum pressure
- built-in electronic temperature control (ETC) for improved baseline stability, and
- built-in holmium oxide filter for fast wavelength accuracy verification.

NOTE

This detectors cannot be operated with a G1323B Control Module. Use the Instant Pilot (G4208A) as local controller.

For specifications refer to [“Performance Specifications \(G1314F\)”](#) on page 44.

Optical System Overview

The optical system of the detector is shown in the figure below. Its radiation source is a deuterium-arc discharge lamp for the ultraviolet (UV) wavelength range from 190 to 600 nm. The light beam from the deuterium lamp passes through a lens, a filter assembly, an entrance slit, a spherical mirror (M1), a grating, a second spherical mirror (M2), a beam splitter, and finally through a flow cell to the sample diode. The beam through the flow cell is absorbed depending on the solutions in the cell, in which UV absorption takes place, and the intensity is converted to an electrical signal by means of the sample photodiode. Part of the light is directed to the reference photodiode by the beam splitter to obtain a reference signal for compensation of intensity fluctuation of the light source. A slit in front of the reference photodiode cuts out light of the sample bandwidth. Wavelength selection is made by rotating the grating, which is driven directly by a stepper motor. This configuration allows fast change of the wavelength. The cutoff filter is moved into the lightpath above 370 nm to reduce higher order light.

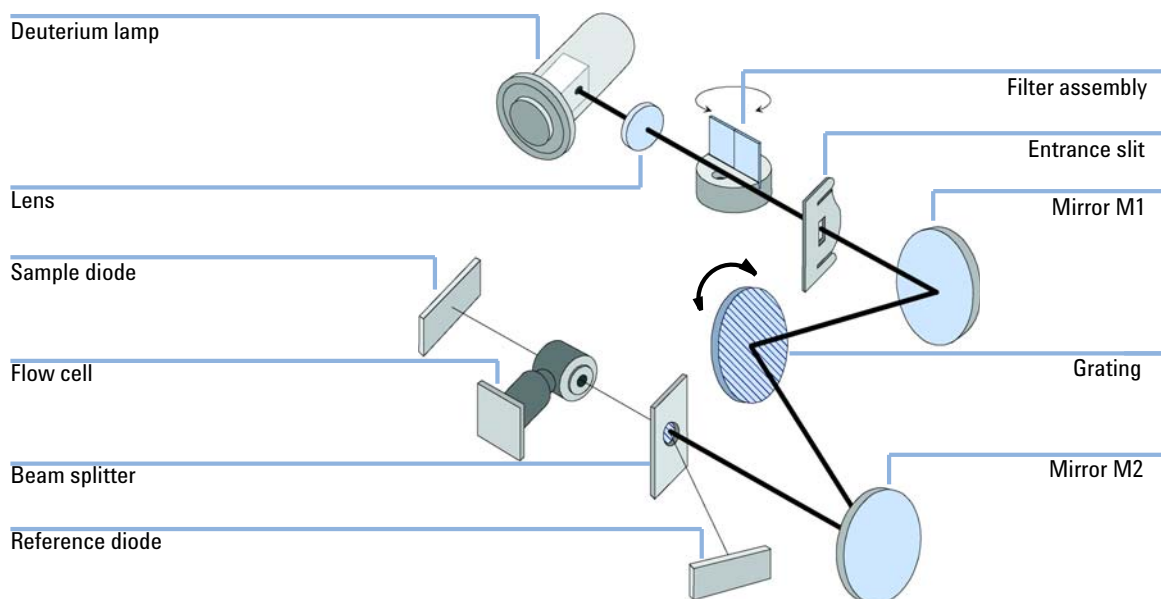

Figure 15 Optical Path of the Variable Wavelength Detector

Flow Cell

A variety of flow-cell cartridges can be inserted using the same quick and simple mounting system.

The flow cells have an integrated RFID tag that contains the flow cell specific information (e.g. part number, cell volume, path length, ...). A RFID tag reader reads out this information and transfers it to the user interface.

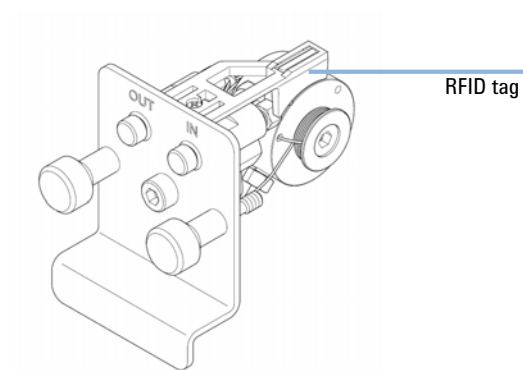

Figure 16 Flow Cell with RFID tag

Table 1 Flow Cell Data

	STD	Semi-micro	Micro	High Pressure	
Maximum pressure	40 (4)	40 (4)	120 (12)	400 (40)	bar
Path length	10 (conical)	6 (conical)	3 (conical)	10 (conical)	mm
Volume	14	5	2	14	μL
Inlet i.d.	0.17	0.17	0.12	0.17	mm
Inlet length	750	750	310	310	mm
Outlet i.d.	0.25	0.25	0.17	0.25	mm
Outlet length	120	120	120	120	mm
Materials in contact with solvent	SST, quartz, PTFE, PEEK	SST, quartz, PTFE	SST, quartz, PTFE	SST, quartz, Kapton	

Lamp

The light source for the UV wavelength range is a deuterium lamp. As a result of plasma discharge in a low pressure deuterium gas, the lamp emits light over the 190 – 600 nm wavelength range.

The lamp has an integrated RFID tag that contains the lamp specific information (e.g. part number, burn time, ...). A RFID tag reader reads out this information and transfers it to the user interface.

Source Lens Assembly

The source lens receives the light from the deuterium lamp and focuses it onto the entrance slit.

Entrance Slit Assembly

The entrance slit assembly has an exchangeable slit. The standard one has a 1-mm slit. For replacement and calibration purposes to optimize the alignment, a slit with a hole is needed.

Filter Assembly

The filter assembly is electromechanically actuated. During wavelength calibrations it moves into the light path.

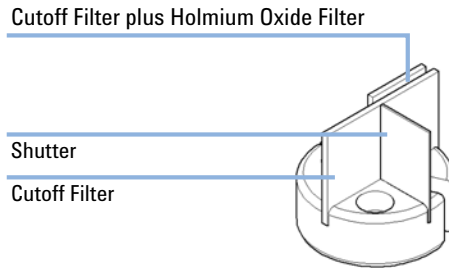

Figure 17 Filter Assembly

The filter assembly has two filters installed and is processor-controlled.

OPEN	nothing in light path at $\lambda < 370$ nm
CUTOFF	cut off filter in light path at $\lambda > 370$ nm
HOLMIUM	holmium oxide filter for wavelength check
SHUTTER	for measurement of dark current of photo diodes

A photo sensor determines the correct position.

Mirror Assemblies M1 and M2

The instrument contains two spherical mirrors (M1 and M2). The beam adjustable is vertically and horizontally. Both mirrors are identical.

Grating Assembly

The grating separates the light beam into all its component wavelengths and reflects the light onto mirror #2.

The stepper motor reference position is determined by a plate fitted onto the motor shaft, interrupting the beam of a photo sensor. The wavelength calibration of the grating is done at the zero order light position and at 656 nm, which is the emission line of the deuterium lamp.

Beam Splitter Assembly

The beam splitter splits the light beam. One part goes directly to the sample diode. The other part of the light beam goes to the reference diode.

Photo Diodes Assemblies

Two photo diode assemblies are installed in the optical unit. The sample diode assembly is located on the left side of the optical unit. The reference diode assembly is located in the front of the optical unit.

Photo Diode ADC (analog-to-digital converter)

The photo diode current is directly converted to digital data direct photo current digitalization. The data is transferred to the detector main board . The photo diode ADC boards are located close to the photo diodes.

1 Introduction

Detector



2 Specifications

Physical Specifications	38
Performance Specifications	40
Specification Conditions	47

This chapter provides information about specifications for the LC system.



Physical Specifications

Table 2 General physical specifications

Type	Specification	Comments
Line voltage	100 – 240 VAC, $\pm 10\%$	Wide-ranging capability
Line frequency	50 or 60 Hz, $\pm 5\%$	
Ambient operating temperature ¹	4 – 55 °C (32 – 131 °F)	See warning “ Hot rear panel ” on page 39
Ambient non-operating temperature	-40 – 70 °C (-4 – 158 °F)	
Humidity	< 95 %, at 25 – 40 °C (77 – 104 °F)	Non condensing
Operating altitude	Up to 2000 m (6562 ft)	
Non-operating altitude	Up to 4600 m (15092 ft)	For storing the module
Safety standards: IEC, CSA, UL, EN		For indoor use only.

¹ This temperature range represents the technical specifications for this instrument. The mentioned temperatures may not be suitable for all applications and all types of solvents.

Table 3 Module specific physical specifications

Module	Weight	Dimension (width x depth x height)	Power consumption
G1311B/C Quaternary pump	11 kg (24 lbs)	140 x 345 x 435 mm (5.5 x 13.5 x 17 inches)	180 VA, 55 W / 188 BTU
G1329B Autosampler	14.2 kg (32 lbs)	200 x 345 x 435 mm (8 x 13.5 x 17 inches)	300 VA, 200 W / 683 BTU
G1330B Thermostat	20.7 kg (46 lbs)	140 x 345 x 435 mm (5.5 x 13.5 x 17 inches)	260 VA, 210 W / 717 BTU
G1316B Thermostatted Column Compartment	11.2 kg (25 lbs)	140 x 345 x 435 mm (5.5 x 13.5 x 17 inches)	320 VA, 150 W / 512 BTU
G4212B DAD	11.5 kg (26 lbs)	140 x 345 x 435 mm (5.5 x 13.5 x 17 inches)	160 VA, 130 W / 444 BTU
G1314F VWD	11 kg (24 lbs)	140 x 345 x 435 mm (5.5 x 13.5 x 17 inches)	220 VA, 85 W / 290 BTU

WARNING

Hot rear panel

Using the autosampler at high environmental temperatures may cause the rear panel to become hot.

- Do not use the autosampler at environmental temperatures higher than 50 °C (122 °F)

Performance Specifications

Performance Specifications (G1311C)

Table 4 Performance Specification Agilent 1260 Infinity Quaternary Pump VL (G1311C)

Type	Specification
Hydraulic system	Dual piston in series pump with proprietary servo-controlled variable stroke drive, floating pistons
Setable flow range	0.001 – 10 mL/min, in 0.001 mL/min increments
Flow range	0.2 – 10.0 mL/min
Flow precision	≤0.07 % RSD, or ≤ 0.02 min SD whatever is greater, based on retention time at constant room temperature
Flow accuracy	± 1 % or 10 µL/min whatever is greater, pumping degassed H ₂ O at 10 MPa
Pressure	Operating range 0 – 40 MPa (0 – 400 bar, 0 – 5880 psi) up to 5 mL/min Operating range 0 – 20 MPa (0 – 200 bar, 0 – 2950 psi) up to 10 mL/min
Pressure pulsation	< 2 % amplitude (typically < 1.0 %), or < 3 bar at 1 mL/min isopropanol, at all pressures > 10 bar (147 psi)
Compressibility compensation	User-selectable, based on mobile phase compressibility
Recommended pH range	1.0 – 12.5, solvents with pH < 2.3 should not contain acids which attack stainless steel
Gradient formation	Low pressure quaternary mixing/gradient capability using proprietary high-speed proportioning valve
Delay volume	600 – 900 µL, dependent on back pressure
Composition range	0 – 95 % or 5 – 100 %, user selectable
Composition precision	< 0.2 % RSD, at 0.2 and 1 mL/min
Control and data evaluation	Agilent control software
Analog output	For pressure monitoring, 2 mV/bar, one output
Communications	Controller-area network (CAN), RS-232C, APG Remote: ready, start, stop and shut-down signals, LAN optional

Performance Specifications (G1316A)

Table 5 Performance Specifications Thermostatted Column Compartment

Type	Specification	Comments
Temperature range	10 degrees below ambient to 80 °C up to 80 °C: flow rates up to 5 mL/min	
Temperature stability	± 0.15 °C	
Temperature accuracy	± 0.8 °C ± 0.5 °C	With calibration
Column capacity	Three 30 cm	
Warm-up/cool-down time	5 minutes from ambient to 40 °C 10 minutes from 40 – 20 °C	
Dead volume	3 µL left heat exchanger 6 µL right heat exchanger	
Communications	Controller-area network (CAN), RS-232C, APG Remote: ready, start, stop and shut-down signals, LAN via other 1260 Infinity module	
Safety and maintenance	Extensive diagnostics, error detection and display (through Instant Pilot and Agilent data system), leak detection, safe leak handling, leak output signal for shutdown of pumping system. Low voltages in major maintenance areas.	
GLP features	Column-identification module for GLP documentation of column type.	
Housing	All materials recyclable	

Performance Specifications (G1329B)

Table 6 Performance Specifications Agilent 1260 Infinity Standard Autosampler (G1329B)

Type	Specification
Pressure	Operating range 0 - 60 MPa (0 - 600 bar, 0 - 8850 psi)
GLP features	Early maintenance feedback (EMF), electronic records of maintenance and errors
Communications	Controller-area network (CAN), GPIB (IEEE-448), RS232C, APG-remote standard, optional four external contact closures and BCD vial number output
Safety features	Leak detection and safe leak handling, low voltages in maintenance areas, error detection and display
Injection range	0.1 - 100 μ L in 0.1 μ L increments (recommended 1 μ L increments) Up to 1500 μ L with multiple draw (hardware modification required)
Replicate injections	1 – 99 from one vial
Precision	Typically < 0.25 % RSD of peak areas from 5 - 100 μ L, Typically < 1 % RSD of peak areas from 1 - 5 μ L,
Minimum sample volume	1 μ L from 5 μ L sample in 100 μ L microvial, or 1 μ L from 10 μ L sample in 300 μ L microvial
Carryover	Typically < 0.1 %, < 0.05 % with external needle cleaning
Sample viscosity range	0.2 – 50 cp
Sample capacity	100 \times 2 mL vials in 1 tray 40 \times 2 mL vials in 1/2 tray 15 \times 6 mL vials in 1/2 tray (Agilent vials only)
Injection cycle time	50 s for draw speed 200 μ L/min, ejection speed 200 μ L/min, injection volume 5 μ L

Performance Specifications (G4212B)

Table 7 Performance Specifications G4212B

Type	Specification	Comments
Detection type	1024-element photodiode array	
Light source	Deuterium lamp	Equipped with RFID tag that holds lamp typical information.
Wavelength range	190 – 640 nm	
Short term noise (ASTM) Single and Multi-Wavelength	$< \pm 3 \times 10^{-6}$ AU at 230 nm/4 nm	see "Specification Conditions" below
Drift	$< 0.5 \times 10^{-3}$ AU/hr at 230 nm	see "Specification Conditions" below
Linear absorbance range	> 2.0 AU (5 %) at 265 nm	see "Specification Conditions" below
Wavelength accuracy	± 1 nm	After recalibration with deuterium lines
Wavelength bunching	2 – 400 nm	Programmable in steps of 1 nm
Slit width	G4212B: 4 nm	Fixed slit
Diode width	~ 0.5 nm	
Signal data rate	80 Hz (G4212B)	
Spectra Data rate	80 Hz (G4212B)	
Flow cells	Max-Light Cartridge Cell (10 mm, V(ϕ) 1.0 µl), 60 bar (870 psi) pressure maximum Max-Light Cartridge Cell (60 mm), V(ϕ) 4.0 µL, 60 bar (870 psi) pressure maximum Max-Light Cartridge Test Cell	pH range 1.0 —12.5 (solvent dependent) Cartridge type, equipped with RFID tags that holds cell typical information.
Control and data evaluation	Data System 1 Agilent ChemStation for LC 2 EZChrom Elite 3 MassHunter	For G4212B: 1 B.04.02 DSP3 or above 2 3.3.2 SP2 or above 3 B.04.00 and B.03.01 SP2 or above
Local Control	Agilent Instant Pilot (G4208A)	B.02.11 or above
Test and diagnostic software	Agilent LabAdvisor	B.01.03 SP4 or above

2 Specifications

Performance Specifications

Table 7 Performance Specifications G4212B

Type	Specification	Comments
Analog outputs	Recorder/integrator: 100 mV or 1 V, output range 0.001 – 2 AU, one output	
Communications	Controller-area network (CAN), RS-232C, APG Remote: ready, start, stop and shut-down signals, LAN	
Safety and maintenance	Extensive diagnostics, error detection and display (through control module and ChemStation), leak detection, safe leak handling, leak output signal for shutdown of pumping system. Low voltages in major maintenance areas.	
GLP features	Early maintenance feedback (EMF) for continuous tracking of instrument usage in terms of lamp burn time with user-settable limits and feedback messages. Electronic records of maintenance and errors. Verification of wavelength accuracy with the emission lines of the deuterium lamp.	
Housing	All materials recyclable.	

Performance Specifications (G1314F)

Table 8 Performance Specifications G1314F

Type	Specification	Comments
Detection type	Double-beam photometer	
Light source	Deuterium lamp	
Wavelength range	190 – 600 nm	The UV-lamp is equipped with RFID tag that holds lamp typical information.
Short term noise	$\pm 0.25 \cdot 10^{-5}$ AU at 230 nm (G1314F)	Under specified conditions. See “ Specification Conditions (VWD) ” on page 48 below the table.

Table 8 Performance Specifications G1314F

Type	Specification	Comments
Drift	< $1 \cdot 10^{-4}$ AU/h at 230 nm	Under specified conditions. See “ Specification Conditions (VWD) ” on page 48 below the table.
Linearity	> 2.5 AU (5 %) at 265 nm	Under specified conditions. See “ Specification Conditions (VWD) ” on page 48 below the table.
Wavelength accuracy	± 1 nm	Self-calibration with deuterium lines, verification with holmium oxide filter
Maximum sampling rate	80 Hz (G1314F)	
Band width	6.5 nm typical	
Flow cells	Standard: 14 µL volume, 10 mm cell path length and 40 bar (588 psi) pressure maximum High pressure: 14 µL volume, cell path length and 400 bar (5880 psi) pressure maximum Micro: 2 µL volume, 3 mm cell path length and 120 bar (1760 psi) pressure maximum Semi-micro: 5 µL volume, 6 mm cell path length and 40 bar (588 psi) pressure maximum	All flow cells have RFID tags for unambiguous identification. Can be repaired on component level
Electronic Temperature Control (ETC)	For improved baseline stability in instable environment.	
Control and data evaluation	Agilent ChemStation B.04.02 SP2 or above (G1314F) Instant Pilot (G4208A) with firmware B.02.11 or above (G1314F)	Control and data evaluation Control only
Time programmable	Wavelength, Reference and Sample scan, balance, steps, lamp on/off	
Spectral tools	Stop-flow wavelength scan	
Analog outputs	Recorder/integrator: 100 mV or 1 V, output range 0.001 – 2 AU, one output	

2 Specifications

Performance Specifications

Table 8 Performance Specifications G1314F

Type	Specification	Comments
Communications	LAN card integrated on main board, Controller-area network (CAN), RS-232C, APG Remote: ready, start, stop and shut-down signals	
Safety and maintenance	Extensive diagnostics, error detection and display (through Instant Pilot and Data System), leak detection, safe leak handling, leak output signal for shutdown of pumping system. Low voltages in major maintenance areas.	
GLP features	Early maintenance feedback (EMF) for continuous tracking of instrument usage in terms of lamp burn time with user-settable limits and feedback messages. Electronic records of maintenance and errors. Verification of wavelength accuracy with built-in holmium oxide filter. RFID for electronics records of flow cell and UV lamp conditions (path length, volume, product number, serial number, test passed, usage)	
Housing	All materials recyclable.	

Specification Conditions

Specification Conditions (DAD)

ASTM: “Standard Practice for Variable Wavelength Photometric Detectors Used in Liquid Chromatography”.

Reference conditions:

- Wavelength: 230 nm/4 nm with Reference Wavelength 360 nm/100 nm, Slitwidth 4 nm, TC 2 s, (or with RT = 2.2 * TC), ASTM
- Max-Light Cartridge Cell (10 mm, V(σ) 1.0 μl) with flow of 0.5 ml/min LC grade water or Max-Light Cartridge Test Cell

Linearity:

Linearity is measured with caffeine at 265 nm/4 nm with slit width 4 nm and TC 1 s (or with RT 2 s) with Max-Light Cartridge Cell (10 mm, V(σ) 1 μl) > 2.0 AU (5 %) [typical 2.5 AU (5 %)] .

NOTE

The specifications are based on the standard RFID tag lamp (5190-0917) and may be not achieved when other lamp types or aged lamps are used.

ASTM drift tests require a temperature change below 2 °C/hour (3.6 F/hour) over one hour period. Our published drift specification is based on these conditions. Larger ambient temperature changes will result in larger drift.

Better drift performance depends on better control of the temperature fluctuations. To realize the highest performance, minimize the frequency and the amplitude of the temperature changes to below 1 °C/hour (1.8 F/hour). Turbulences around one minute or less can be ignored.

Performance tests should be done with a completely warmed up optical unit (> two hours). ASTM measurements require that the detector should be turned on at least 24 h before start of testing.

Specification Conditions (VWD)

ASTM: “Standard Practice for Variable Wavelength Photometric Detectors Used in Liquid Chromatography”.

Reference conditions: Standard flow cell, path length 10 mm, flow 1 mL/min LC-grade methanol.

Noise:

$\pm 0.15 \cdot 10^{-5}$ AU (G1314E/D), $\pm 0.25 \cdot 10^{-5}$ AU (G1314F) at 230 nm, TC 2 s

RT = 2.2 * TC

Linearity:

Linearity is measured with caffeine at 265 nm.

NOTE

The specification are based on the the standard RFID tag lamp (G1314-60101) and may be not achieved when other lamp types or aged lamps are used.

ASTM drift tests require a temperature change below 2°C/hour (3.6°F/hour) over one hour period. Our published drift specification is based on these conditions. Larger ambient temperature changes will result in larger drift.

Better drift performance depends on better control of the temperature fluctuations. To realize the highest performance, minimize the frequency and the amplitude of the temperature changes to below 1°C/hour (1.8°F/hour). Turbulences around one minute or less can be ignored.

Performance tests should be done with a completely warmed up optical unit (> one hour). ASTM measurements require that the detector should be turned on at least 24 hours before start of testing.

Time Constant versus Response Time

According to ASTM E1657-98 „Standard Practice of Testing Variable-Wavelength Photometric Detectors Used in Liquid Chromatography” the time constant is converted to response time by multiplying by the factor 2.2.



3 Optimization of the Agilent 1260 Infinity Quaternary LC VL

Optimizing the Pump	50
Operational Hints for the Vacuum Degasser	50
Operational Hints for the Multi Channel Gradient Valve (MCGV)	50
When to Use the Seal Wash Option	51
Choosing the Right Pump Seals	52
Optimize the Compressibility Compensation Setting	52
Optimizing the Autosampler	54
Optimization for Lowest Carry-over	54
Fast Injection Cycle and Low Delay Volume	57
Precise Injection Volume	58
Choice of Rotor Seal	60
Optimizing the Thermostatted Column Compartment	61
Optimizing the Detector Regarding to the System	62
Delay Volume and Extra-Column Volume	62
Optimizing Detection with DAD	63
Introduction	63
Optimization Overview	64
Optimizing for Sensitivity, Selectivity, Linearity and Dispersion	65
Optimizing Selectivity	73
Warm up of the Detector	76
Optimizing Detection with VWD	78
Optimizing the Detector Performance	78
Match the Flow Cell to the Column	78
Set the Detector Parameters (VWD)	81

This chapter considers how to apply the theory and use the features of the LC system to develop optimized separations.



Optimizing the Pump

Operational Hints for the Vacuum Degasser

Operational Hints for the Vacuum Degasser

If you are using the vacuum degasser for the first time, if the vacuum degasser was switched off for any length of time (for example, overnight), or if the vacuum degasser lines are empty, you should prime the vacuum degasser before running an analysis.

The vacuum degasser can be primed either by drawing solvent through the degasser with a syringe or by pumping with the quaternary pump.

Priming the degasser with a syringe is recommended, when:

- vacuum degasser is used for the first time, or vacuum tubes are empty, or
- changing to solvents that are immiscible with the solvent currently in the vacuum tubes.

Priming the vacuum degasser by using the quaternary pump at high flow rate is recommended, when:

- quaternary pump was turned off for a length of time (for example, during night) and volatile solvent mixtures are used, or
- solvents have been changed.

For more information see the *Service Manual* for the Agilent 1200 Series vacuum degasser.

Operational Hints for the Multi Channel Gradient Valve (MCGV)

In a mixture of salt solutions and organic solvent the salt solution might be well dissolved in the organic solvent without showing precipitations. However in the mixing point of the gradient valve, at the boundary between the two solvents, micro precipitation is possible. Gravity forces the salt particles to fall down. Normally the A channel of the valve is used for the aqueous/salt solution and the B channel of the pump is used for the organic solvent. If used

in this configuration the salt will fall back into the salt solution and will be dissolved. When using the pump in a different configuration (e.g., D - salt solution, A - organic solvent) the salt can fall into the port of the organic solvent and may lead to performance problems.

NOTE

When using salt solutions and organic solvents it is recommended to connect the salt solution to one of the bottom ports of the MCGV and the organic solvent to one of the upper gradient valve ports. It is best to have the organic channel directly above the salt solution channel. Regular flushing with water of all MCGV channels is recommended to remove all possible salt deposits in the valve ports.

When to Use the Seal Wash Option

Highly concentrated buffer solutions will reduce the lifetime of the seals and pistons in your pump. The seal wash option allows to maintain the seal lifetime by flushing the back side of the seal with a wash solvent.

The seal wash option is strongly recommended when buffer concentrations of 0.1 M or higher will be used for long time periods in the pump.

The active seal wash upgrade can be ordered as G1398A.

The seal wash option comprises a support ring, secondary seal, gasket and seal holder for both piston sides. A wash bottle filled with water /isopropanol (90/10) is placed above the pump in the solvent cabinet and the peristaltic pump moves a flow through the pump head removing all possible buffer crystals from the back of the pump seal.

NOTE

Running dry is the worst case for a wash seal and drastically reduces its lifetime.

The seal will build up sticky layers on the surface of the piston. These sticky layers will also reduce the lifetime of the pump seal. Therefore the tubes of the wash option should always be filled with solvent to prolong the lifetime of the wash seal. Always use a mixture of LC grade water (90 %) and isopropanol (10 %) as wash solvent. This mixture prevents growth of algae or bacteria in the wash bottle and reduces the surface tension of the water.

Choosing the Right Pump Seals

The standard seal for the pump can be used for most applications. However applications that use normal phase solvents (for example, hexane) are not suited for the standard seal and require a different seal when used for a longer time in the pump.

For applications that use normal phase solvents (for example, hexane) we recommend using polyethylene pump seals (PE seals (pack of 2) (p/n 0905-1420)) and Wash Seal PE (p/n 0905-1718). These seals have less abrasion compared to the standard seals.

NOTE

Polyethylene seals have a limited pressure range of 0 – 200 bar. When used above 200 bar their lifetime is reduced significantly. *DO NOT* apply the seal wear-in procedure performed with new standard seals at 400 bar.

Optimize the Compressibility Compensation Setting

The compressibility compensation default setting is 100×10^{-6} /bar for the pump. This setting represents an average value. Under normal conditions the default setting reduces the pressure pulsation to values (below 1% of system pressure) that will be sufficient for most applications and for all gradient analyses. For applications using sensitive detectors, the compressibility settings can be optimized by using the values for the various solvents described in [Table 9](#) on page 53. If the solvent in use is not listed in the compressibility tables, when using isocratic mixtures of solvents and if the default settings are not sufficient for your application the following procedure can be used to optimize the compressibility settings.

NOTE

When using mixtures of solvents it is not possible to calculate the compressibility of the mixture by interpolating the compressibility values of the pure solvents used in that mixture or by applying any other calculation. In these cases the following empirical procedure has to be applied to optimize your compressibility setting.

- 1 Start the pump with the required flow rate.
- 2 Before starting the optimization procedure, the flow must be stable. Check the tightness of the system with the pressure test.

- 3** Your pump must be connected to a data system or Instant Pilot with which the pressure and %-ripple can be monitored, otherwise connect a signal cable between the pressure output of the pump and a recording device (for example, 339X integrator) and set parameters.

Zero 50 %

Att 2^3 Chart

Speed 10 cm/min

- 4** Start the recording device with the plot mode.
- 5** Starting with a compressibility setting of 10×10^{-6} /bar increase the value in steps of 10. Re-zero the integrator as required. The compressibility compensation setting that generates the smallest pressure ripple is the optimum value for your solvent composition.

Table 9 Solvent Compressibility

Solvent (pure)	Compressibility (10^{-6} /bar)
Acetone	126
Acetonitrile	115
Benzene	95
Carbon tetrachloride	110
Chloroform	100
Cyclohexane	118
Ethanol	114
Ethyl acetate	104
Heptane	120
Hexane	150
Isobutanol	100
Isopropanol	100
Methanol	120
1-Propanol	100
Toluene	87
Water	46

Optimizing the Autosampler

Optimization for Lowest Carry-over

Several parts of an injection system can contribute to carry-over:

- needle outside
- needle inside
- needle seat
- sample loop
- seat capillary
- injection valve

The autosampler continuous flow-through design ensures that sample loop, needle inside, seat capillary, and the mainpass of the injection valve is always in the flow line. These parts are continuously flushed during an isocratic and also during a gradient analysis. The residual amount of sample remaining on the outside of the needle after injection may contribute to carry-over in some instances. When using small injection volumes or when injecting samples of low concentration immediately after samples of high concentration, carry-over may become noticeable. Using the automated needle wash enables the carry-over to be minimized and prevents also contamination of the needle seat.

Using the Automated Needle Wash

The automated needle wash can be programmed either as “injection with needle wash” or the needle wash can be included into the injector program. When the automated needle wash is used, the needle is moved into a wash vial after the sample is drawn. By washing the needle after drawing a sample, the sample is removed from the surface of the needle immediately.

Uncapped Wash Vial

For best results, the wash vial should contain solvent in which the sample components are soluble, and the vial should *not* be capped. If the wash vial is capped, small amounts of sample remain on the surface of the septum, which may be carried on the needle to the next sample.

Injector Program with Needle Wash

The injector program includes the command NEEDLE WASH. When this command is included in the injector program, the needle is lowered once into the specified wash vial before injection.

For example:

```
1 DRAW 5 µl  
2 NEEDLE WASH vial 7  
3 INJECT
```

Line 1 draws 5 µl from the current sample vial. Line 2 moves the needle to vial 7. Line 3 injects the sample (valve switches to main pass).

Using an Injector Program

The process is based on a program that switches the bypass groove of the injection valve into the flow line for cleaning. This switching event is performed at the end of the equilibration time to ensure that the bypass groove is filled with the start concentration of the mobile phase. Otherwise the separation could be influenced, especially if microbore columns are used.

3 Optimization of the Agilent 1260 Infinity Quaternary LC VL Optimizing the Autosampler

For example:

Outside wash of needle in vial 7 before injection

Injector program:

Draw x.x (y) μ l from sample

NEEDLE WASH vial 7

Inject

Wait (equilibration time - see text above)

Valve bypass

Wait 0.2 min

Valve mainpass

Valve bypass

Valve mainpass

NOTE

Overlapped injection together with additional injection valve switching is not possible.

General Recommendation to Lowest Carry-over

- For samples where needle outside cannot be cleaned sufficiently with water or alcohol use wash vials with an appropriate solvent. Using an injector program and several wash vials can be used for cleaning.

In case the needle seat has got contaminated and carry-over is significantly higher than expected, the following procedure can be used to clean the needle seat:

- Go to **MORE INJECTOR** and set needle to home position.
- Pipette an appropriate solvent on to the needle seat. The solvent should be able to dissolve the contamination. If this is not known use 2 or 3 solvents of different polarity. Use several milliliters to clean the seat.
- Clean the needle seat with a tissue and remove all liquid from it.
- **RESET** the injector.

Fast Injection Cycle and Low Delay Volume

Short injection cycle times for high sample throughput is one of the most important requirements in analytical laboratories. In order to shorten cycle times, you can:

- shorten the column length
- use high flow rates
- apply a steep gradient

Having optimized these parameters, further reduction of cycle times can be obtained using the overlapped injection mode.

Overlapped Injection Mode

In this process, as soon as the sample has reached the column, the injection valve is switched back to bypass and the next injection cycle starts but waits with switching to mainpass until the actual run is finished. You gain the sample preparation time when using this process.

Switching the valve into the bypass position reduces the system delay volume, the mobile phase is directed to the column without passing sample loop, needle and needle seat capillary. This can help to have faster cycle times especially if low flow rates have to be used like it is mandatory in narrow bore and micro bore HPLC.

NOTE

Having the valve in bypass position can increase the carry-over in the system.

The injection cycle times also depend on the injection volume. In identically standard condition, injecting 100 μl instead of 1 μl , increase the injection time by approximately 8 sec. In this case and if the viscosity of the sample allows it, the draw and eject speed of the injection system has to be increased.

NOTE

For the last injection of the sequence with overlapped injections it has to be considered that for this run the injection valve is not switched as for the previous runs and consequently the injector delay volume is not bypassed. This means the retention times are prolonged for the last run. Especially at low flow rates this can lead to retention time changes which are too big for the actual calibration table. To overcome this it is recommended to add an additional "blank" injection as last injection to the sequence.

General Recommendations for Fast Injection Cycle Times

As described in this section, the first step to provide short cycle times are optimizing the chromatographic conditions. If this is done the autosampler parameter should be set to:

- Overlapped injection mode
- Increase of draw and eject speed for large injection volumes
- Add at last run a blank, if overlapped injection is used

To reduce the injection time, the detector balance has to be set to OFF.

Precise Injection Volume

Injection Volumes Less Than 2 μL

When the injection valve switches to the BYPASS position, the mobile phase in the sample loop is depressurized. When the syringe begins drawing sample, the pressure of the mobile phase is decreased further. If the mobile phase is not degassed adequately, small gas bubbles may form in the sample loop during the injection sequence. When using injection volumes $< 2 \mu\text{L}$, these gas bubbles may affect the injection-volume precision. For best injection-volume precision with injection volumes $< 2 \mu\text{L}$, use of an Agilent 1260 Infinity degasser is recommended to ensure the mobile phase is adequately degassed. Also, using the automated needle wash (see [“Optimization for Lowest Carry-over”](#) on page 54) between injections reduces carry-over to a minimum, further improving the injection volume precision.

Draw and Eject Speed

Draw Speed

The speed at which the metering unit draws sample out of the vial may have an influence on the injection volume precision when using viscous samples. If the draw speed is too high, air bubbles may form in the sample plug, affecting precision. The default draw speed is 200 $\mu\text{L}/\text{min}$. This speed is suitable for the majority of applications, however, when using viscous samples, set the draw speed to lower speed for optimum results. A DRAW statement in an injector

program also uses the draw speed setting which is configured for the autosampler.

Eject Speed

The default eject speed setting is 200 $\mu\text{L}/\text{min}$. When using large injection volumes, setting the eject speed to a higher value speeds up the injection cycle by shortening the time the metering unit requires to eject solvent at the beginning of the injection cycle (when the plunger returns to the home position).

An EJECT statement in an injector program also uses the eject speed setting which is configured for the autosampler. A faster eject speed shortens the time required to run the injector program. When using viscous samples, a high eject speed should be avoided.

Choice of Rotor Seal

Vespe^l™ Seal (for standard valves only)

The standard seal has sealing material made of Vespe^l. Vespe^l is suitable for applications using mobile phases within the pH range of 2.3 to 9.5, which is suitable for the majority of applications. However, for applications using mobile phases with pH below 2.3 or above 9.5, the Vespe^l seal may degrade faster, leading to reduced seal lifetime.

Tefze^l™ Seal (for standard valves only)

For mobile phases with pH below 2.3 or above 9.5, or for conditions where the lifetime of the Vespe^l seal is drastically reduced, a seal made of Tefze^l is available. Tefze^l is more resistant than Vespe^l to extremes of pH, however, is a slightly *softer* material. Under normal conditions, the expected lifetime of the Tefze^l seal is shorter than the Vespe^l seal, however, Tefze^l may have the longer lifetime under more extreme mobile phase conditions.

PEEK Seal (for preparative injection valve only)

The preparative injection valve has a sealing material made of PEEK. This material has high chemical resistance and versatility. It is suitable for application using mobile phases within a pH between 1 and 14.

NOTE

Strong oxidizing acids such as concentrated nitric and sulfuric acids are not compatible with PEEK.

Optimizing the Thermostatted Column Compartment

For best performance results of the column compartment:

- Use short connection capillaries and place them close to the heat exchanger. This will reduce heat dissipation and external band-broadening.
- Use the left heat exchanger for small volume columns, for example, 2 – 3 mm i.d. columns at flow rates of less than 200 $\mu\text{L}/\text{min}$.
- For even lower band-broadening, the heat exchanger can be by-passed and the column is placed well between the heat exchanger fins.
- Keep the left and right heat exchanger temperature the same unless you do specific applications.
- Assure that the front cover is always closed.

Optimizing the Detector Regarding to the System

Delay Volume and Extra-Column Volume

The *delay volume* is defined as the system volume between the point of mixing in the pump and the top of the column.

The *extra-column volume* is defined as the volume between the injection point and the detection point, excluding the volume in the column.

Extra-Column Volume

Extra-column volume is a source of peak dispersion that will reduce the resolution of the separation and so should be minimized. Smaller diameter columns require proportionally smaller extra-column volumes to keep peak dispersion at a minimum.

In a liquid chromatograph the extra-column volume will depend on the connection tubing between the autosampler, column and detector; and on the volume of the flow cell in the detector. The extra-column volume is minimized with the Agilent 1290 Infinity/Agilent 1260 Infinity LC System due to the narrow-bore (0.12 mm i.d.) tubing, the low-volume heat exchangers in the column compartment and the Max-Light cartridge cell in the detector.

Optimizing Detection with DAD

Introduction

The detector has a variety of parameters that can be used to optimize performance. Depending on whether signal or spectral data need to be optimized, different settings are recommended. The following sections describe optimization for:

- signal sensitivity, selectivity and linearity,
- spectral sensitivity and resolution (DAD only), and
- disk space required for storing data.

NOTE

The information in this chapter should be seen as a basic introduction to diode array detector techniques. Some of these techniques may not be available in the instrument software controlling the detector.

How to Get the Best Detector Performance

The information below will guide you on how to get the best detector performance. Follow these rules as a start for new applications. It gives rules-of-thumb for optimizing detector parameters.

Optimization Overview

Table 10 Optimization Overview

Parameter	Impact
1 Selection of flow cell <ul style="list-style-type: none"> Choose flow cell according to used column, see "Choosing a Flow Cell" on page 65. 	<ul style="list-style-type: none"> peak resolution versus sensitivity
2 Connection of flow cell <ul style="list-style-type: none"> For flow rates from 0.5 ml/min connect column using the zero-dead-volume fittings of the detector. For small column i.d. (e.g 1 mm) the inlet capillary of the micro flow cell can be connected directly to the column. 	<ul style="list-style-type: none"> chromatographic resolution
3 Setting the peak width (response time) <ul style="list-style-type: none"> Use peak width according "Choosing a Flow Cell" on page 65 as starting point. Set the peak-width close to the width of a narrow peak of interest in your chromatogram. 	<ul style="list-style-type: none"> peak resolution versus sensitivity versus disk space
4 Setting wavelength and bandwidth <ul style="list-style-type: none"> Sample wavelength: <ul style="list-style-type: none"> Never miss a peak by the use of a browser wavelength like 250 nm with 100 nm bandwidth. Select specific wavelength with reduced bandwidth if you need selectivity, e.g. 250,10 nm and 360,100 nm as reference wavelength. Set the sample wavelength to a peak or valley in the spectrum to get best linearity for high concentrations. Reference wavelength: <ul style="list-style-type: none"> Select the reference wavelength with broad bandwidth (30...100 nm) wavelength range where your analytes have little or no absorbance (e.g. sample at 254 nm, reference at 320 nm). 	<ul style="list-style-type: none"> sensitivity versus selectivity sensitivity versus linearity baseline drift due to RI effects.

Choosing a Flow Cell

The Max-Light Cartridge Cell with path length 10 mm and volume (σ) 1.0 μ l covers a wide range of applications:

- all column diameter down to at least 2.1 mm ID or even less
- applications with peak dispersion (Peakwidth x flow) down to ~ 2 μ l
 [example: pw = 0.04 min at flow = 0.1 ml/min gives peak dispersion of
 0.04 min x 0.1 ml/min = 0.004 ml = 4 μ l]

If higher sensitivity is necessary, the Max-Light Cartridge Cell with path length 60 mm and volume (σ) 4 μ L can be used. This cell enhances the detector by lowering the limit of detection (LOD) by a factor of about 3 (depending on the application).

Optimizing for Sensitivity, Selectivity, Linearity and Dispersion

Flow Cell Path Length

Lambert-Beer's law shows a linear relationship between the flow cell path length and absorbance.

$$\text{Absorbance} = -\log T = \log \frac{I_0}{I} = \epsilon \times C \times d$$

where

T is the transmission, defined as the quotient of the intensity of the transmitted light I divided by the intensity of the incident light, I_0 ,

ϵ is the extinction coefficient, which is a characteristic of a given substance under a precisely-defined set of conditions of wavelength, solvent, temperature and other parameters,

C [mol/L] is the concentration of the absorbing species, and

d [cm] is the path length of the cell used for the measurement.

The detector can now output the signal in two forms:

- 1 In Absorbance divide by the path length AU/cm, that is then similar to [$\epsilon \times C$]. Advantage: samples with same concentration have same peak height also at cells with different path lengths.

3 Optimization of the Agilent 1260 Infinity Quaternary LC VL Optimizing Detection with DAD

The upper limit of concentration: the linearity limit of the detector is then seen at about 2 AU/path length, so for the 6 cm Max-Light Cartridge Cell the linearity limit is 333 mAU/cm].

- 2 In AU that is equal to $\epsilon \times C \times d$ like normal done in the past: now for recalculation to your concentration C the path length must be considered.

Therefore, flow cells with longer path lengths yield higher signals. Although noise usually increases little with increasing path length, there is a gain in signal-to-noise ratio.

When increasing the path length, the cell volume could increase. Depending on the peak volume, this could cause more peak dispersion.

As a rule-of-thumb the flow cell volume should be about 1/3 of the peak volume at half height. To determine the volume of your peaks, take the peak width as reported in the integration results multiply it by the flow rate and divide it by 3).

NOTE

This may result in problems when the used peak width is set to large and all peaks are filtered accordingly.

Traditionally LC analysis with UV detectors is based on comparing measurements with internal or external standards. To check photometric accuracy of the Agilent detector it is necessary to have more precise information on path lengths of the detector flow cells.

Part Number	Path Length	Cell Volume (σ)
G4213-60008	1.0 cm	1.0 μ L
G4213-60007	6.0 cm	4.0 μ L

Peak width (response time)

Response time describes how fast the detector signal follows a sudden change of absorbance in the flow cell. The detector uses digital filters to adapt response time to the width of the peaks in your chromatogram. These filters do not affect peak area nor peak symmetry. When set correctly, such filters reduce baseline noise significantly ([Figure 18](#) on page 67), but reduce peak height only slightly. In addition, these filters reduce the data rate to allow

optimum integration and display of your peaks and to minimize disk space required to store chromatograms and spectra.

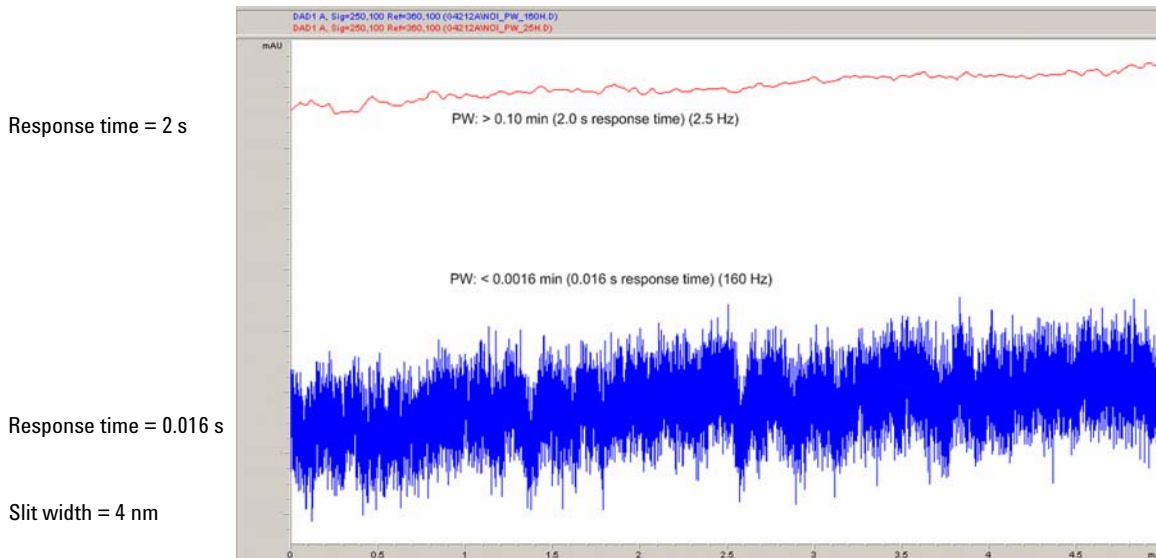

Figure 18 Influence of Response Time on Signal and Noise

Table 11 on page 68 lists the filter choices of the detector. To get optimum results, set peak width as close as possible to a narrow peak of interest in your chromatogram. Response time will be approximately 1/3 of the peak width, resulting in less than 5 % peak-height reduction and less than 5 % additional peak dispersion. Decreasing the peak width setting in the detector will result in less than 5 % gain in peak height but baseline noise will increase by a factor of 1.4 for a factor of 2 response-time reduction. Increasing peak width (response time) by factor of two from the recommended setting (over-filtering) will reduce peak height by about 20 % and reduce baseline noise by a factor of 1.4. This gives you the best possible signal-to-noise ratio, but may affect peak resolution.

3 Optimization of the Agilent 1260 Infinity Quaternary LC VL Optimizing Detection with DAD

Table 11 Peak Width — Response Time — Data Rate

Peak width at half height [min] ¹	Response [s]	Signal data rate [Hz]	Scan data rate [HZ] ≤126 pts/scan	Scan data rate [HZ] ≤251 pts/scan	Scan data rate [HZ] ≤501 pts/scan	Scan data rate [HZ] >501 pts/scan
< 0.0016	0.016	160 ²	160 ²	80	40	20
> 0.0016	0.03	160 ²	160 ²	80	40	20
> 0.003	0.062	80	80	80	80	40
> 0.006	0.12	40	40	40	40	40
> 0.012	0.25	20	20	20	20	20
> 0.025	0.5	10	10	10	10	10
> 0.05	1.0	5	5	5	5	5
> 0.10	2.0	2.5	2.5	2.5	2.5	2.5
> 0.20	4.0	1.25	1.25	1.25	1.25	1.25
> 0.40	8.0	0.625	0.62	0.625	0.625	0.625
> 0.85	16.0	0.3125	0.31	0.3125	0.3125	0.3125

¹ Values in the User Interface may be rounded.

² G4212A only

NOTE

The maximum spectra scan rate depends on the data points per scan, see [Table 11](#) on page 68. Running at 160 Hz, the spectra scan data rate is reduced automatically if the spectra scan data rate is more than 251 points/scan.

Sample and Reference Wavelength and Bandwidth

The detector measures absorbance simultaneously at wavelengths from 190 to 640 nm. A UV-lamp provides good sensitivity over the whole wavelength range.

If you know little about the analytes in your sample, store all spectra over the full wavelength range. This provides full information but fills up your disk space rather quickly. Spectra can be used to check a peak's purity and identity. Spectral information is also useful to optimize wavelength settings for your chromatographic signal.

The detector can compute and store at run time up to 8 signals with these properties:

- sample wavelength, the center of a wavelength band with the width of sample bandwidth (BW), and optionally
- reference wavelength, the center of a wavelength band with the width of reference bandwidth.

The signals comprises a series of data points over time, with the average absorbance in the sample wavelength band minus the average absorbance of the reference wavelength band.

Signal A in the detector default method is set to sample 254.0/4, reference 360.0/100, that is, the average absorbance from 252 – 256 nm minus the average absorbance from 310 – 410 nm. As all analytes show higher absorbance at 252 – 256 nm than at 310 – 410 nm, this signal will show you virtually every compound which can be detected by UV absorbance.

Many compounds show absorbance bands in the spectrum. [Figure 19](#) on page 70 shows the spectrum of anisic acid as an example. To optimize for lowest possible detectable concentrations of anisic acid, set the sample wavelength to the peak of the absorbance band (that is, 252 nm) and the sample bandwidth to the width of the absorbance band (that is, 30 nm). A reference of 360,100 is adequate. Anisic acid does not absorb in this range.

If you work with high concentrations, you may get better linearity above 1.5 AU by setting the sample wavelength to a valley in the spectrum, like 225 nm for anisic acid.

3 Optimization of the Agilent 1260 Infinity Quaternary LC VL Optimizing Detection with DAD

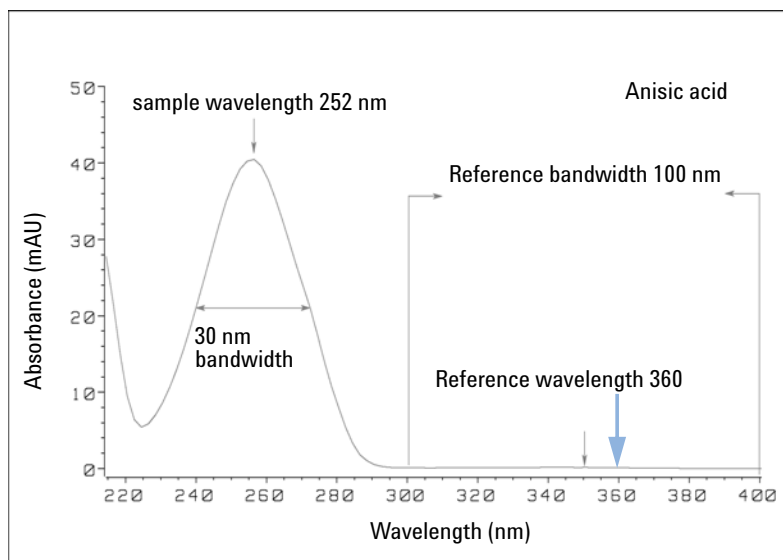

Figure 19 Optimization of Wavelength Setting

A wide bandwidth has the advantage of reducing noise by averaging over a wavelength range – compared to a 4 nm bandwidth, the baseline noise is reduced by a factor of approximately 2.5, whereas the signal is about 75 % of a 4 nm wide band. The signal-to-noise ratio for a 30 nm bandwidth is twice that for a 4 nm bandwidth in our example.

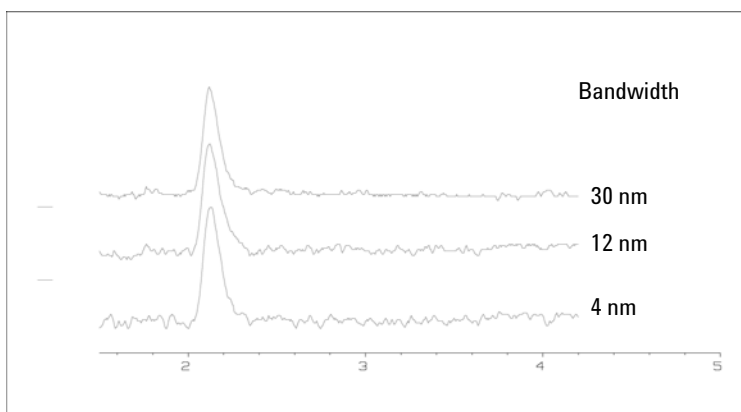

Figure 20 Influence of Bandwidth on Signal and Noise

Because the detector averages absorbance values that are calculated for each wavelength, using a wide bandwidth does not negatively impact linearity.

The use of a reference wavelength is highly recommended to further reduce baseline drift and wander induced by room temperature fluctuations or refractive index changes during a gradient.

An example of the reduction of baseline drifts is shown in [Figure 21](#) on page 71 for PTH-amino acids. Without a reference wavelength, the chromatogram drifts downwards due to refractive index changes induced by the gradient. This is almost completely eliminated by using a reference wavelength. With this technique, PTH-amino acids can be quantified in the low picomole range even in a gradient analysis.

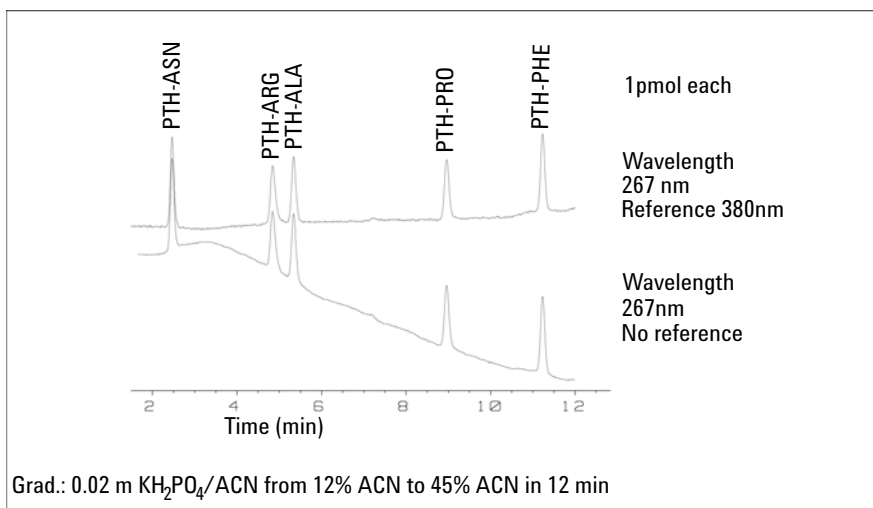

Figure 21 Gradient Analysis of PTH-Amino Acids (1 pmol each), with and without Reference

Optimizing Spectral Acquisition (DAD only)

Storage of all spectra consumes a lot of disk space. It is very useful to have all spectra available during optimization of a method or when analyzing unique samples. However when running many samples of the same type, the large size of data files with all spectra may become a burden. The detector provides functions to reduce the amount of data, yet retaining the relevant spectral information.

Range

Only the wavelength range where the compounds in your sample absorb contains information that is useful for purity checks and library searches. Reducing the spectrum storage range saves disk space.

Step

Most substances have broad absorbance bands. Display of spectra, peak purity and library search works best if a spectrum contains 5 to 10 data points per width of the absorbance bands. For anisic acid (the example used before) a step of 4 nm would be sufficient. However a step of 2 nm gives a more optimal display of the spectrum.

Threshold

Sets the peak detector. Only spectra from peaks higher than threshold will be stored when a peak-controlled storage mode is selected.

Margin for Negative Absorbance

The detector adjusts its gain during *balance* such that the baseline may drift slightly negative (about -100 mAU). In some special case, for example, when gradient with absorbing solvents are used, the baseline may drift to more negative values.

Only for such cases, increase the margin for negative absorbance to avoid overflow of the analog-to-digital converter.

Optimizing Selectivity

Quantifying Coeluting Peaks by Peak Suppression

In chromatography, two compounds may often elute together. A conventional dual-signal detector can only detect and quantify both compounds independently from each other if their spectra do not overlap. However, in most cases this is highly unlikely.

With a dual-channel detector based on diode-array technology, quantifying two compounds is possible even when both compounds absorb over the whole wavelength range. The procedure is called peak suppression or signal subtraction. As an example, the analysis of hydrochlorothiazide in the presence of caffeine is described. If hydrochlorothiazide is analyzed in biological samples, there is always a risk that caffeine is present which might interfere chromatographically with hydrochlorothiazide. As the spectra in [Figure 22](#) on page 73 shows, hydrochlorothiazide is best detected at 222 nm, where caffeine also shows significant absorbance. It would therefore be impossible, with a conventional variable wavelength detector, to detect hydrochlorothiazide quantitatively when caffeine is present.

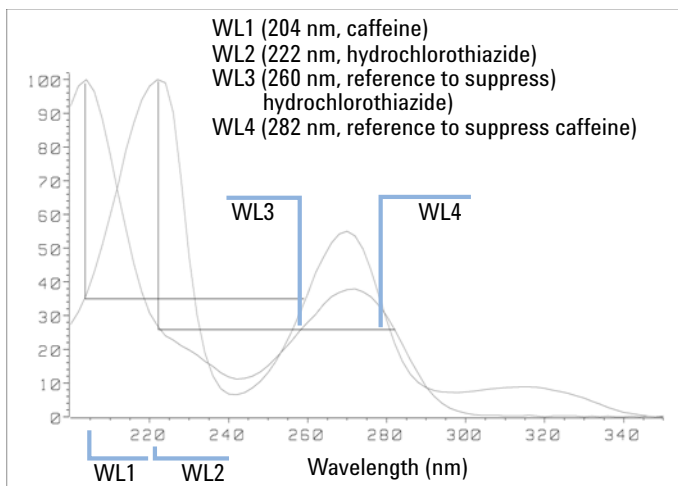

Figure 22 Wavelength Selection for Peak Suppression

With a UV-visible detector based on a diode array and the correct choice of a reference wavelength setting, quantitative detection is possible. To suppress

caffeine, the reference wavelength must be set to 282 nm. At this wavelength, caffeine shows exactly the same absorbance as at 222 nm. When the absorbance values are subtracted from each other, any indication of the presence of caffeine is eliminated. In the same way, hydrochlorothiazide can be suppressed if caffeine is to be quantified. In this case the wavelength is set to 204 nm and the reference wavelength to 260 nm. [Figure 23](#) on page 74 shows the chromatographic results of the peak suppression technique.

The trade-off for this procedure is a loss in sensitivity. The sample signal decreases by the absorbance at the reference wavelength relative to the signal wavelength. Sensitivity may be decreased by as much as 10–30 %.

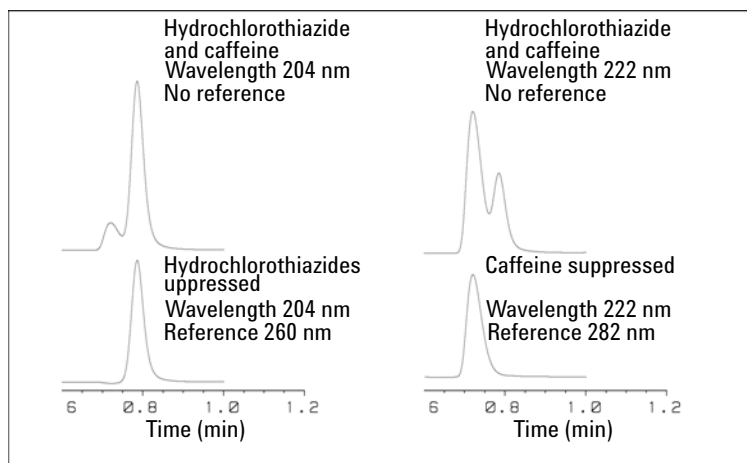

Figure 23 Peak Suppression Using Reference Wavelength

Ratio Qualifiers for Selective Detection of Compound Classes

Ratio qualifiers can be used where, in a complex sample, only one particular class needs to be analyzed – a parent drug and its metabolites in a biological sample, for example. Another example is the selective analysis of derivatives after pre- or post-column derivatization. Specifying a signal ratio that is typical for the sample class is one way of selectively plotting only those peaks that are of interest. The signal output remains at zero so long as the ratio is out of the user-specified ratio range. When the ratio falls within the range, the signal output corresponds to the normal absorbance, giving single, clear peaks on a flat baseline. An example is shown in [Figure 24](#) on page 75 and [Figure 25](#) on page 75.

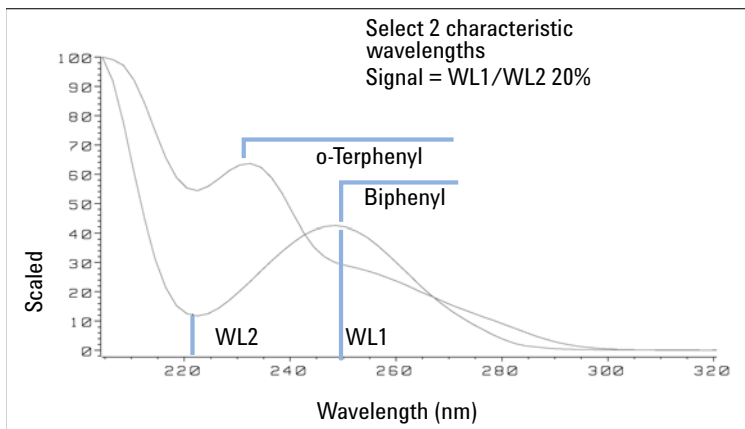

Figure 24 Wavelength Selection for Ratio Qualifiers

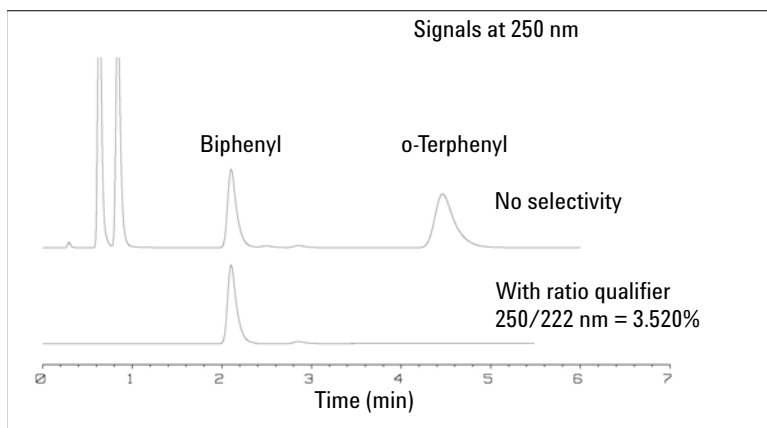

Figure 25 Selectivity by Ratio Qualifiers

In a four-component mixture, only biphenyl was recorded. The other three peaks were suppressed because they did not meet the ratio-qualifier criterion and therefore the output was set to zero. The characteristic wavelengths 249 nm (λ_1) and 224 nm (λ_2) were found from the spectra shown in [Figure 24](#) on page 75. The ratio range was set at 2 – 2.4 ($2.2 \pm 10\%$). Only when the ratio between 249 and 224 nm was within this range, is the signal plotted. Of all four peaks, only the third fulfilled the criterion ([Figure 25](#) on page 75). The others were not plotted.

Warm up of the Detector

Give the optical unit enough time to warm-up and stabilize (> 60 minutes). The detector is temperature controlled. After turn-on of the detector, it goes through a cycle of different states:

- 0 to 0.5 minutes the heater control is OFF and the heater element runs at 0 % duty cycle.
- 0.5 to 1 minutes the heater control is OFF and the heater element runs at 66% duty cycle. This first minute is used as self-test of the heater functionality.
- 1 to 30 minutes the heater control is OFF and the heater element runs at 40% duty cycle.
- After 30 minutes the heater control is ON and is working with optimized parameters to get the optical unit into the optimal temperature window stabilized.

This cycle starts

- when the detector is turned off/on
- when the lamp is turned off/on

to ensure that the temperature control operates in a defined control range.

NOTE

The times to stabilize the baseline may vary from instrument to instrument and depends on the environment. The example below was done under stable environmental conditions.

The figures below show the first two hours of a detector warm-up phase. The lamp was turned on immediately after turn on of the detector.

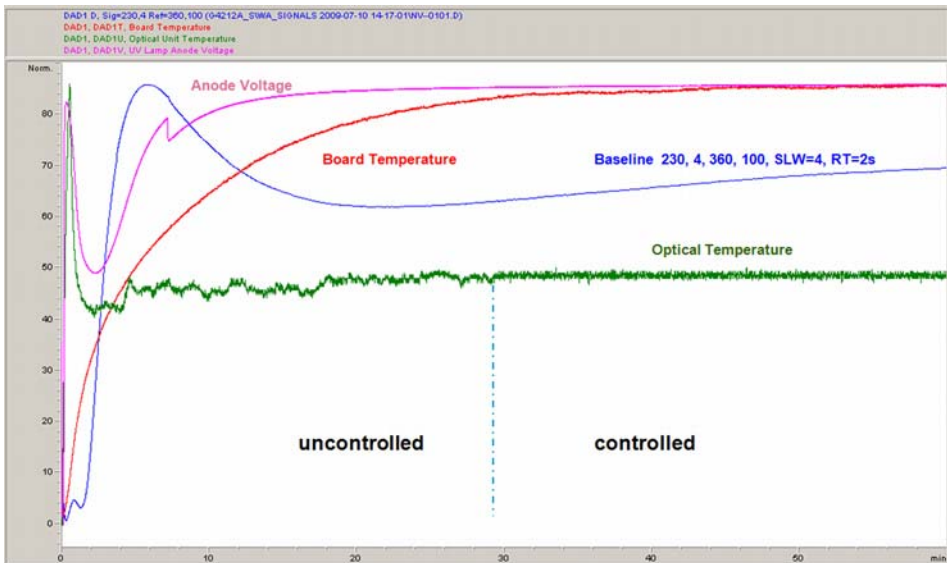

Figure 26 Detector Warm-up – 1st hour

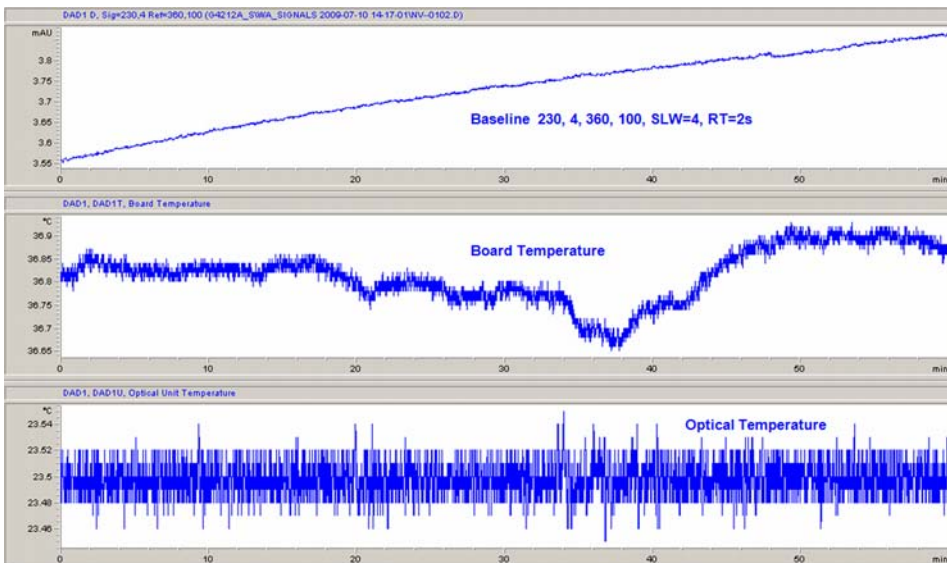

Figure 27 Detector Warm-up – 2nd hour

Optimizing Detection with VWD

Optimizing the Detector Performance

The detector has a variety of parameters that can be used to optimize performance.

The information below will guide you on how to get the best detector performance. Follow these rules as a start for new applications. It gives a rule-of-thumb for optimizing the detector parameters.

Match the Flow Cell to the Column

Standard HPLC Applications

Column length	Typical peak width	Recommended flow cell				
<= 5 cm	0.025 min	Micro flow cell	Semimicro flow cell		High Pressure flow cell	
10 cm	0.05 min		Standard flow cell		High Pressure flow cell	
20 cm	0.1 min		Standard flow cell		High Pressure flow cell	
>= 40 cm	0.2 min		Standard flow cell		High Pressure flow cell	
	Typical flow rate	0.05-0.2 ml/min	0.2- 0.4 ml/min	0.4- 0.8 ml/min	1-2 ml/min	0.01- 5 ml/min
	Internal column diameter	1.0 mm	2.1mm	3.0 mm	4.6 mm	

Figure 28 Choosing a Flow Cell (Standard HPLC Applications)

Flow Cell Path Length

Lambert-Beer's law shows a linear relationship between the flow cell path length and absorbance.

$$\text{Absorbance} = -\log T = \log \frac{I_0}{I} = \epsilon \times C \times d$$

where

T	is the transmission, defined as the quotient of the intensity of the transmitted light I divided by the intensity of the incident light, I ₀ .
e	is the extinction coefficient, which is a characteristic of a given substance under a precisely-defined set of conditions of wavelength, solvent, temperature and other parameters,
C [mol/L]	is the concentration of the absorbing species,
d [cm]	is the path length of the cell used for the measurement.

Therefore, flow cells with longer path lengths yield higher signals. Although noise usually increases little with increasing path length, there is a gain in signal-to-noise ratio. For example, in [Figure 29](#) on page 80 the noise increased by less than 10 % but a 70 % increase in signal intensity was achieved by increasing the path length from 6 mm [Figure 29](#) on page 80 to 10 mm.

When increasing the path length, the cell volume usually increases – in the example from 5 – 13 µL. Typically, this causes more peak dispersion. As demonstrated, this did not affect the resolution in the gradient separation in the example shown below.

As a rule-of-thumb the flow cell volume should be about 1/3 of the peak volume at half height. To determine the volume of your peaks, take the peak width as reported in the integration results multiply it by the flow rate and divide it by 3).

3 Optimization of the Agilent 1260 Infinity Quaternary LC VL Optimizing Detection with VWD

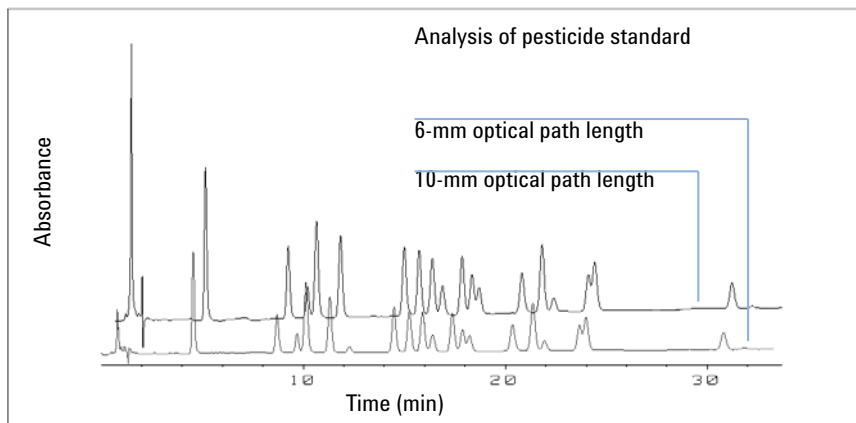

Figure 29 Influence of Cell Path Length on Signal Height

Traditionally LC analysis with UV detectors is based on comparing measurements with internal or external standards. To check photometric accuracy of the Agilent 1200 Series Infinity Variable Wavelength Detector it is necessary to have more precise information on path lengths of the VWD flow cells.

The correct response is:

expected response * correction factor

Please find below the details of the Agilent 1200 Infinity Series Variable Wavelength Detector flow cells:

Table 12 Correction factors for Agilent VWD flow cells

Part number	Path length (actual)	Correction factor
Standard flow cell 10 mm, 14 μ L (p/n G1314-60186)	10.15 \pm 0.19 mm	10/10.15
Semi-micro flow cell 6 mm, 5 μ L (p/n G1314-60183)	6.10 \pm 0.19 mm	6/6.10
Micro flow cell 3 mm, 2 μ L (p/n G1314-60187)	2.80 \pm 0.19 mm	3/2.8
High pressure flow cell 10 mm, 14 μ L (p/n G1314-60182)	10.00 \pm 0.19 mm	6/5.75

NOTE

However you have to be aware that there are additional tolerance of gasket thickness and its compression ratio which is supposed to be very small in comparison with the machining tolerance.

Set the Detector Parameters (VWD)

- 1 Set peakwidth as close as possible to the width (at half height) of a narrow peak of interest.
- 2 Choose the sample wavelength.
 - at a longer wavelength than the cut-off wavelength of the mobile phase,
 - at a wavelength where the analytes have strong absorptivity if you want to get the lowest possible detection limit,
 - at a wavelength with moderate absorptivity if you work with high concentrations, and
 - preferably where the spectrum is flat for better linearity.
- 3 Consider to use time-programming to further optimization.

3 Optimization of the Agilent 1260 Infinity Quaternary LC VL **Optimizing Detection with VWD**



4 System Setup and Installation

Installing Software	84
Installing the Modules	85
Priming the System	86
Integration Into the Network	90

This chapter includes information on software installation, stack configurations and preparing the system for operation.



Installing Software

Installing the Software Controller and Data System

For details of installation procedures for the software, refer to the detector manual and the software manuals.

Installing the Agilent Lab Advisor Software

For details of installation procedures for the Agilent Lab Advisor software, refer to the software documentation on the Lab Advisor DVD.

Agilent Lab Advisor replaces and extends upon the diagnostic functions that were formerly only in the ChemStation software.

Agilent Lab Advisor is a Windows®-based application that continuously monitors instruments in the lab in real time and increases productivity through automatic notification of maintenance and service needs with the use of advanced counters. This allows a problem to be fixed before it impacts results. The software includes an extensive suite of user information and documentation, a set of calculators and tools to help set up, calibrate, and maintain your instrument, and tests and diagnostic routines to verify proper performance. Agilent Lab Advisor also provides feedback and solutions for any instrument errors that may arise. The software will work with or without Agilent data systems.

The software monitors:

- LC module status
- Early Maintenance Feedback (to determine the need for upgrade or replacement)

In addition, the software:

- Automates useful tests,
- Attempts to identify supported LAN-based instruments that are powered on and connected to your PC or lab's network,
- Automatically suggests replacements parts and troubleshooting tasks for some common instrument problems.

Installing the Modules

Installing the System Modules

For details of installation procedures for the modules, refer to the individual module manuals. These manuals also contain information on specifications, maintenance and parts.

Stack Configuration

You can ensure optimum performance by installing the system in one stack and two stack configurations (“[One Stack Configuration](#)” on page 12 and “[Two Stack Configuration](#)” on page 15). These configurations optimize the system flow path, ensuring minimum delay volume.

Priming the System

Initial Priming

When Before a new degasser or new solvent tubing can be used, it is necessary to prime the system. Isopropanol (IPA) is recommended as priming solvent due to its miscibility with nearly all HPLC solvents and its excellent wetting properties.

Parts required

#	Description
1	Isopropanol

Preparations Connect all modules hydraulically as described in the respective module manuals.
Fill each solvent bottle with 100 mL isopropanol
Switch the system on

WARNING

When opening capillary or tube fittings solvents may leak out.

The handling of toxic and hazardous solvents and reagents can bear health risks.

→ Please observe appropriate safety procedures (for example, goggles, safety gloves and protective clothing) as described in the material handling and safety data sheet supplied by the solvent vendor, especially when toxic or hazardous solvents are used.

NOTE

The purge tool of the LabAdvisor or Instrument Utilities can be used for automatically purging the pump.

NOTE

If the pump is not able to aspirate the solvent from the bottles, a syringe can be used to draw the solvent manually through tubing and degasser.

NOTE

When priming the vacuum degasser with a syringe, the solvent is drawn through the degasser tubes very quickly. The solvent at the degasser outlet will therefore not be fully degassed. Pump for approximately 10 minutes at your desired flow rate before starting an analysis. This will allow the vacuum degasser to properly degas the solvent in the degasser tubes.

- 1** Open the purge valve of the pump
- 2** Set the flow rate to 5 mL/min.
- 3** Select channel A1
- 4** Turn the flow on
- 5** Observe if the solvent in the tubing of channel A1 is advancing towards the pump. If it isn't, disconnect the solvent tubing from the solvent selection valve, attach a syringe with a syringe adapter and pull the liquid through the degasser. Reattach the tubing to the solvent selection valve.
- 6** Pump 30 mL isopropanol to remove residual air bubbles.
- 7** Switch to the next solvent channel and repeat steps 5 and 6 until all channels have been purged.
- 8** Turn the flow off and close the purge valve.

4 System Setup and Installation

Installing the Modules

Regular Priming

When When the pumping system has been turned off for a certain time (for example, overnight) air will rediffuse into the solvent channel between the vacuum degasser and the pump. Solvents containing volatile ingredients will slightly lose these if left in the degasser without flow for a prolonged period of time.

Preparations Switch the system on

NOTE

The purge tool of the LabAdvisor or Instrument Utilities can be used for automatically purging the pump.

- 1 Open the purge valve of your pump by turning it counterclockwise and set the flow rate to 5 mL/min.
- 2 Flush the vacuum degasser and all tubes with at least 10 mL of solvent.
- 3 Repeat step 1 and 2 for the other channel(s) of the pump.
- 4 Set the required composition and flow rate for your application and close the purge valve.
- 5 Pump for approximately 10 minutes before starting your application.

Changing Solvents

When When the solvent of a channel is to be replaced by another solvent that is not compatible (solvents are immiscible or one solvent contains a buffer) it is necessary to follow the procedure below to prevent clogging of the pump by salt precipitation or residual liquid droplets in parts of the system.

Parts required

#	Description
1	Purging solvent(s), see Table 13 on page 90

Preparations Remove the column and replace it by a ZDV fitting.
Prepare bottles with appropriate intermediate solvents (see [Table 13](#) on page 90)

- 1 If the channel is not filled with a buffer, proceed to step 4.
- 2 Place the solvent intake filter into a bottle of water.
- 3 Flush the channel at a flow rate suitable for the installed tubing (typically 3-5 mL/min) for 10 min.
- 4 Modify the flow path of your system as required for your application. For delay volume optimization see the Rapid Resolution System manual.

CAUTION

Buffer salt of aqueous buffers may precipitate in residual isopropanol.

Capillaries and filter may be clogged by precipitating salt.

→ Don't perform steps 5 to 7 for channels run with aqueous buffer as solvent.

- 5 Replace the solvent bottle by a bottle of isopropanol.
- 6 Flush the channel at a flow rate suitable for the installed tubing (typically 3-5 mL/min) for 5 min.
- 7 Swap the bottle of isopropanol with a bottle of solvent for your application.
- 8 Repeat steps 1 to 7 for the other channel(s) of the pump.
- 9 Install the desired column, set the required composition and flow rate for your application and equilibrate the system for approx. 10 minutes prior to starting a run.

4 System Setup and Installation

Installing the Modules

Table 13 Choice of Priming Solvents for Different Purposes

Activity	Solvent	Comments
After an installation	Isopropanol	Best solvent to flush air out of the system
When switching between reverse phase and normal phase (both times)	Isopropanol	Miscible with almost all solvents
After an installation	Ethanol or methanol	Alternative to isopropanol (second choice) if no isopropanol is available
To clean the system when using buffers	HPLC grade water	Best solvent to re-dissolve buffer crystals
After changing aqueous solvents	HPLC grade water	Best solvent to re-dissolve buffer crystals
After the installation of normal phase seals (P/N 0905-1420)	Hexane + 5% isopropanol	Good wetting properties

Integration Into the Network

For network integration of your system refer to user manuals of your modules (chapter *LAN Configuration*).

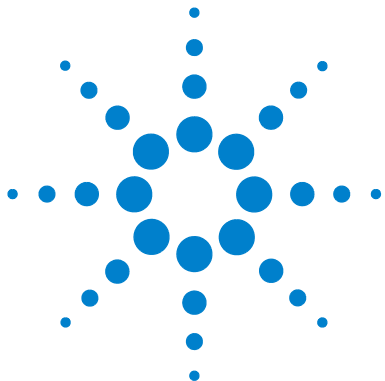

5 Quick Start Guide

Preparing the System	92
Turning the System ON	92
Loading the Default Method	93
Configuring the Online Plot	94
Purging the Pump	96
Setting Up the Method	97

This chapter provides information on data acquisition and data analysis with the Agilent 1260 Infinity Quaternary LC VL.



Preparing the System

Turning the System ON

If the system is not already fully on with the software showing Ready status, follow these steps:

- 1 Turn on the computer system and wait for the Windows desktop to appear.
- 2 Turn on the electrical power to the LC modules using the button at the lower left of each module.

A green power on light will be visible in the center of the button.

- 3 Start the control software on the computer by clicking the icon (if configured). Alternatively, you can select **Start > All Programs > Agilent ChemStation > Agilent ChemStation Instrument 1 Online**. As more than one instrument system may be connected to the computer, the number (1, 2, ...) indicates the system number.

The ChemStation software opens in the **Method and Run Control** view. The modules are initially in Standby mode and Not Ready status, except for the autosampler which immediately initializes and becomes Ready.

- 4 To switch on each module individually, right-click the relevant icon and select **Switch [module name] on** from the context menu.

Alternatively, you can turn on all modules simultaneously in the system by clicking the **System On/Off** button in the bottom right of the system diagram. The system status changes from *Not Ready* (yellow indication) to *Ready* (green indication) after a short delay as the setpoints are attained.

Loading the Default Method

The ChemStation has a default method named **DEF_LC.M** which is loaded at first execution or whenever a new blank method template is required. It contains default settings for all modules.

With this procedure, you load the method **DEF_LC.M**. You can use it to set all parameters to default settings, or to get a blank method template before setting up a new method.

- 1 Go to **Method and Run Control** view of the ChemStation.
- 2 On the menu bar, select **Method > New Method...**, and select **DEF_LC.M** from the context menu.

Alternatively, you can use the **Load Method** icon  under the menu bar, or double-click the method name **DEF_LC.M** in the **Methods** tab of the Navigation Pane.

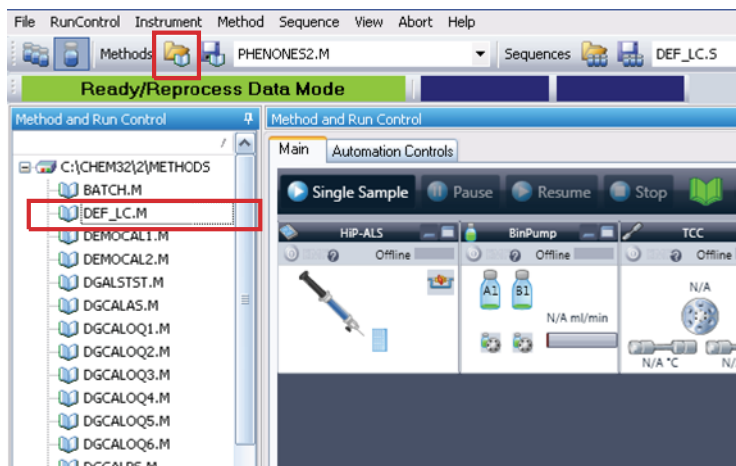

The default method (**DEF_LC.M**) has a set of default parameters which can then be modified to create a new method. For instance, the flow rate is set to zero, and the **Method Information** and **Method History** are blank.

NOTE

Note that this method can never be overwritten with new parameters. Hence clicking on **Save** will re-direct you into the **Save As...** function, so that you must enter a different method name.

Configuring the Online Plot

- 1 If the **Online Plot** window is not visible: Click **View > Online Signals > Signal Window 1** to display the window.

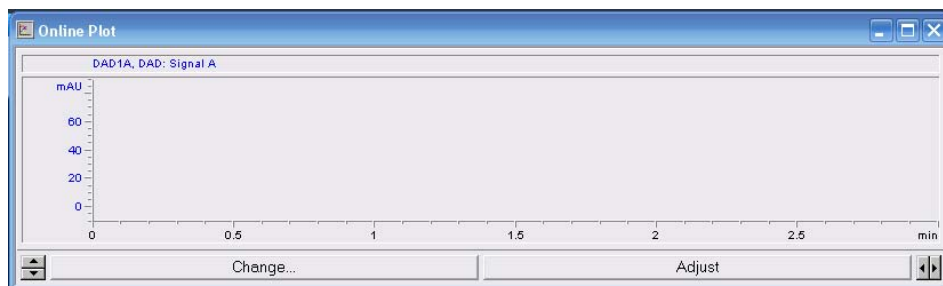

- 2 To configure the desired signal(s) in the **Online Plot** window, click **Change....**
The **Edit Signal Plot** setup page opens.

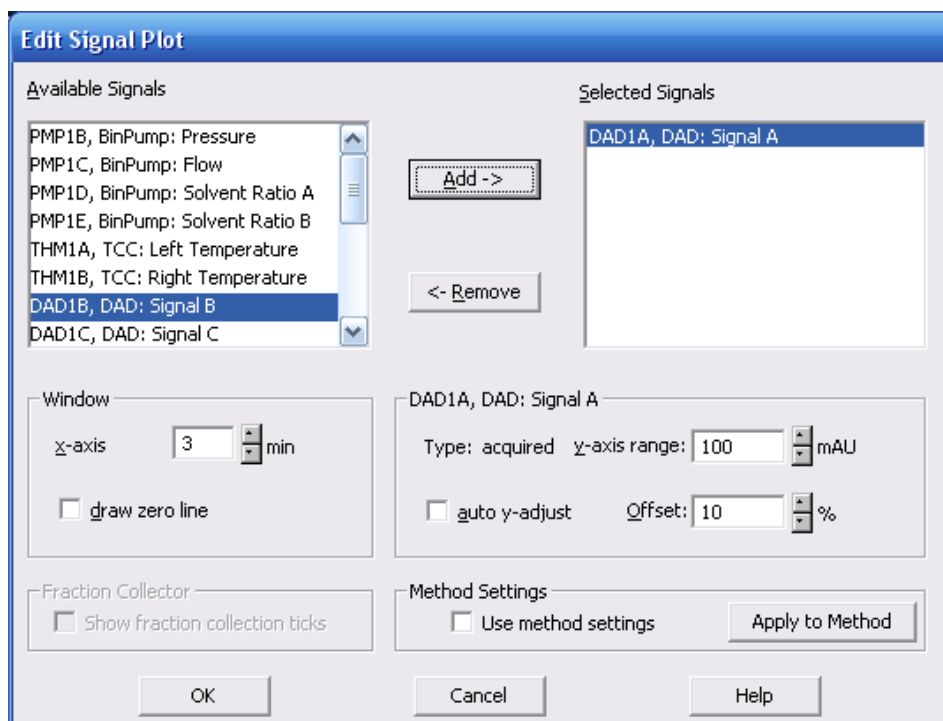

- 3 In the **Available Signals** box, highlight the required signal(s), and click **Add** to move them to the **Selected Signals** box.

- 4 To configure the individual settings for each signal, highlight the signal in the **Selected Signal** box and set the required values in the lower half of the page.

NOTE

In addition to the detector signals, parameter traces such as temperature and pressure can also be plotted. With **Apply to Method**, the settings in this page can be stored into the method.

The **Online Plot** window behaves like electronic chart paper, continuously recording the output from the detector(s) and other output parameters. The signals are drawn at the right of the window and move away to the left. Up to 90 min of past data is accessible. This is useful for checking the baseline and looking at previous injections. The X and Y-axis scales can be adjusted directly with the up/down buttons on each axis.

The **Adjust** button in the **Online Plot** window moves the current point on the selected signal to the zero line. The selected signal is indicated by the color of the Y-axis labels. A particular signal may be selected by clicking on the signal or by clicking on the relevant signal description at the top of the plot.

The **Balance** button zeroes all detectors when pressed.

NOTE

Changes made in the **Online Plot** page do not in any way affect the data stored into the individual data files.

Purging the Pump

Purge the pump, if ...

- The pump has been primed for the first time.
- The pump is to be purged with fresh solvent before using the system, or when the solvent is to be exchanged for another.
- The pump has been idle for a few hours or more (air may have diffused into the solvent lines and purging is recommended).
- The solvent reservoirs are refilled, and the pump requires purging to fill the system with fresh solvent. If different solvents are to be used, ensure that the new solvent is miscible with the previous solvent and if necessary use an intermediate step with a co-miscible solvent (isopropanol is often a good choice, check with a solvent miscibility table).

For details on the purging procedure, refer to [“Priming the System”](#) on page 86.

Setting Up the Method

This section shows how to quickly set the method conditions for an analysis.

The default method **DEF_LC.M** has been loaded ready to prepare the new method. Now the key parameters can be edited to create the new method.

- 1 To quickly access the **Method** page for each module, right-click in the system diagram for the module and select **Method...** from the context menu.

Each of the modules will be set up in this way.

- 2 Right-click the pump area, and select **Method...** in the context menu.
 - a In the **Method** page for the **1260 Infinity Quaternary Pump**, enter the following parameters:
 - Flow rate: 1.5 ml/min
 - Solvent A: Select **Water** from the compressibility drop-down list.
 - Solvent B: Select the check box to make Solvent B active.
 - %B: Initial value 65 %
 - Stop Time: 6 min
 - Max Pressure Limit: 400 bar
 - b Click the + sign to open the **Timetable**.
 - c Add a line, select **Change Solvent Composition**, and set %B to 80 %
 - d Other parameters can remain at default settings. Click **OK** to exit the window.

The changes are sent to the pump module.

- 3 Right-click the autosampler area, and select **Method...** in the context menu.
 - a In the **Method** page for the **1260 Infinity Autosampler**, enter the following parameters:
 - Injection volume: 1.0 µl
 - Injection with Needle Wash
 - Mode Flush Port, Time: 6 s
 - b Other parameters can remain at default settings. Click **OK** to exit the window.

The changes are sent to the autosampler module.

- 4** Right-click the Thermostatted Column Compartment (TCC) area, and select **Method...** in the context menu.
 - a** In the **Method** page for the **1260 Infinity TCC**, enter the following parameters:
 - Left Temperature 40 °C
 - Right Temperature Combined
 - b** Other parameters can remain at default settings. Click **OK** to exit the window.

The changes are sent to the TCC module.
- 5** Right-click the Diode-Array Detector area, and select **Method...** in the context menu.
 - a** In the **Method** page for the **1260 Infinity DAD**, enter the following parameters:
 - **Use Signal:** Turn all signals except **Signal A** off by clearing the check boxes.
 - Signal A: 250 nm, bw 100 nm, ref 360 nm, bw 100 nm
 - Peak width: 0.012 min (0.25 s Response, 20 Hz)
 - b** In the **Advanced** section, set **Spectrum Store** to **All**.
 - c** Other parameters can remain at default settings. Click **OK** to exit the window.

The changes are sent to the DAD module.
- 6** All the required module parameters have now been entered. Select **Method > Save Method As...ISO-1.M** to save the method with a new name.

The ChemStation will not allow the method to be saved as **DEF_LC.M**, so that the default method template is not altered.
- 7** Allow the system to equilibrate for at least 10 min, and check that the baseline in the **Online Plot** is stable before starting the analysis.



6 Appendix

Safety	100
The Waste Electrical and Electronic Equipment Directive	103
Lithium Batteries Information	104
Radio Interference	105
Sound Emission	106
Solvent Information	107
UV-Radiation	108
Declaration of Conformity for HOX2 Filter	109
Agilent Technologies on Internet	110





This chapter provides addition information on safety, legal, web and the Edit Entire Method.



Safety

Safety Symbols

Table 14 Safety Symbols

Symbol	Description
	The apparatus is marked with this symbol when the user should refer to the instruction manual in order to protect risk of harm to the operator and to protect the apparatus against damage.
	Indicates dangerous voltages.
	Indicates a protected ground terminal.
	Indicates eye damage may result from directly viewing the light produced by the deuterium lamp used in this product.
	The apparatus is marked with this symbol when hot surfaces are available and the user should not touch it when heated up.

WARNING

A WARNING

alerts you to situations that could cause physical injury or death.

- Do not proceed beyond a warning until you have fully understood and met the indicated conditions.

CAUTION

A CAUTION

alerts you to situations that could cause loss of data, or damage of equipment.

- Do not proceed beyond a caution until you have fully understood and met the indicated conditions.

General Safety Information

The following general safety precautions must be observed during all phases of operation, service, and repair of this instrument. Failure to comply with these precautions or with specific warnings elsewhere in this manual violates safety standards of design, manufacture, and intended use of the instrument. Agilent Technologies assumes no liability for the customer's failure to comply with these requirements.

WARNING

Ensure the proper usage of the equipment.

The protection provided by the equipment may be impaired.

→ The operator of this instrument is advised to use the equipment in a manner as specified in this manual.

Safety Standards

This is a Safety Class I instrument (provided with terminal for protective earthing) and has been manufactured and tested according to international safety standards.

Operation

Before applying power, comply with the installation section. Additionally the following must be observed.

Do not remove instrument covers when operating. Before the instrument is switched on, all protective earth terminals, extension cords, auto-transformers, and devices connected to it must be connected to a protective earth via a ground socket. Any interruption of the protective earth grounding will cause a potential shock hazard that could result in serious personal injury. Whenever it is likely that the protection has been impaired, the instrument must be made inoperative and be secured against any intended operation.

Make sure that only fuses with the required rated current and of the specified type (normal blow, time delay, and so on) are used for replacement. The use of repaired fuses and the short-circuiting of fuse holders must be avoided.

Some adjustments described in the manual, are made with power supplied to the instrument, and protective covers removed. Energy available at many points may, if contacted, result in personal injury.

Any adjustment, maintenance, and repair of the opened instrument under voltage should be avoided whenever possible. When inevitable, this has to be carried out by a skilled person who is aware of the hazard involved. Do not attempt internal service or adjustment unless another person, capable of rendering first aid and resuscitation, is present. Do not replace components with power cable connected.

Do not operate the instrument in the presence of flammable gases or fumes. Operation of any electrical instrument in such an environment constitutes a definite safety hazard.

Do not install substitute parts or make any unauthorized modification to the instrument.

Capacitors inside the instrument may still be charged, even though the instrument has been disconnected from its source of supply. Dangerous voltages, capable of causing serious personal injury, are present in this instrument. Use extreme caution when handling, testing and adjusting.

When working with solvents please observe appropriate safety procedures (e.g. goggles, safety gloves and protective clothing) as described in the material handling and safety data sheet by the solvent vendor, especially when toxic or hazardous solvents are used.

The Waste Electrical and Electronic Equipment Directive

Abstract

The Waste Electrical and Electronic Equipment (WEEE) Directive (2002/96/EC), adopted by EU Commission on 13 February 2003, is introducing producer responsibility on all electric and electronic appliances starting with 13 August 2005.

NOTE

This product complies with the WEEE Directive (2002/96/EC) marking requirements. The affixed label indicates that you must not discard this electrical/electronic product in domestic household waste.

Product Category:

With reference to the equipment types in the WEEE Directive Annex I, this product is classed as a Monitoring and Control Instrumentation product.



NOTE

Do not dispose off in domestic household waste

To return unwanted products, contact your local Agilent office, or see www.agilent.com for more information.

Lithium Batteries Information

WARNING

Lithium batteries may not be disposed-off into the domestic waste. Transportation of discharged Lithium batteries through carriers regulated by IATA/ICAO, ADR, RID, IMDG is not allowed.

Danger of explosion if battery is incorrectly replaced.

- Discharged Lithium batteries shall be disposed off locally according to national waste disposal regulations for batteries.
 - Replace only with the same or equivalent type recommended by the equipment manufacturer.
-



WARNING

Lithiumbatteri - Eksplosionsfare ved fejlagtig håndtering.

Udskiftning må kun ske med batteri af samme fabrikat og type.

- Lever det brugte batteri tilbage til leverandøren.
-

WARNING

Lithiumbatteri - Eksplosionsfare.

Ved udskiftning benyttes kun batteri som anbefalt av apparatfabrikanten.

- Brukt batteri returneres apparatleverandøren.
-

NOTE

Bij dit apparaat zijn batterijen geleverd. Wanneer deze leeg zijn, moet u ze niet weggooien maar inleveren als KCA.

Radio Interference

Cables supplied by Agilent Technologies are screened to provide optimized protection against radio interference. All cables are in compliance with safety or EMC regulations.

Test and Measurement

If test and measurement equipment is operated with unscreened cables, or used for measurements on open set-ups, the user has to assure that under operating conditions the radio interference limits are still met within the premises.

Sound Emission

Manufacturer's Declaration

This statement is provided to comply with the requirements of the German Sound Emission Directive of 18 January 1991.

This product has a sound pressure emission (at the operator position) < 70 dB.

- Sound Pressure $L_p < 70$ dB (A)
- At Operator Position
- Normal Operation
- According to ISO 7779:1988/EN 27779/1991 (Type Test)

Solvent Information

Flow Cell

To protect optimal functionality of your flow-cell:

- Avoid the use of alkaline solutions (pH > 9.5) which can attack quartz and thus impair the optical properties of the flow cell.

Use of Solvents

Observe the following recommendations on the use of solvents.

- Brown glass ware can avoid growth of algae.
- Avoid the use of the following steel-corrosive solvents:
 - Solutions of alkali halides and their respective acids (for example, lithium iodide, potassium chloride, and so on),
 - High concentrations of inorganic acids like sulfuric acid and nitric acid, especially at higher temperatures (if your chromatography method allows, replace by phosphoric acid or phosphate buffer which are less corrosive against stainless steel),
 - Halogenated solvents or mixtures which form radicals and/or acids, for example:

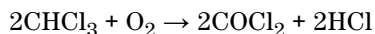

This reaction, in which stainless steel probably acts as a catalyst, occurs quickly with dried chloroform if the drying process removes the stabilizing alcohol,

- Chromatographic grade ethers, which can contain peroxides (for example, THF, dioxane, di-isopropylether) such ethers should be filtered through dry aluminium oxide which adsorbs the peroxides,
- Solvents containing strong complexing agents (e.g. EDTA),
- Mixtures of carbon tetrachloride with 2-propanol or THF.

UV-Radiation

Emissions of ultraviolet radiation (200-315 nm) from this product is limited such that radiant exposure incident upon the unprotected skin or eye of operator or service personnel is limited to the following TLVs (Threshold Limit Values) according to the American Conference of Governmental Industrial Hygienists:

Table 15 UV-Radiation Limits



Exposure/day	Effective Irradiance
8 hours	0.1 $\mu\text{W}/\text{cm}^2$
10 minutes	5.0 $\mu\text{W}/\text{cm}^2$

Typically the radiation values are much smaller than these limits:

Table 16 UV-Radiation Typical Values

Position	Effective Irradiance
Lamp installed, 50-cm distance	average 0.016 $\mu\text{W}/\text{cm}^2$
Lamp installed, 50-cm distance	maximum 0.14 $\mu\text{W}/\text{cm}^2$

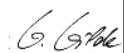
Declaration of Conformity for HOX2 Filter

Declaration of Conformity				
We herewith inform you that the				
Holmium Oxide Glass Filter				
used in Agilent's absorbance detectors listed in the table below meets the requirements of National Institute of Standards and Technology (NIST) to be applied as certified wavelength standard.				
According to the publication of NIST in J. Res. Natl. Inst. Stand. Technol. 112, 303-306 (2007) the holmium oxide glass filters are inherently stable with respect to the wavelength scale and need no recertification. The expanded uncertainty of the certified wavelength values is 0.2 nm.				
Agilent Technologies guarantees, as required by NIST, that the material of the filters is holmium oxide glass representing the inherently existent holmium oxide absorption bands.				
Test wavelengths:				
Product Number	Series	Measured Wavelength *	Wavelength Accuracy	Optical Bandwidth
79883A	1090	361.0 nm	+/- 1 nm	2 nm
79854A	1050	418.9 nm		
G1306A	1050	453.7 nm		
G1315A, G1365A	1100	536.7 nm		
G1315B/C, G1365B/C	1100 / 1200 / 1260			
G1600A, G7100A	CE			
79853C	1050	360.8nm 418.5nm 536.4nm	+/- 2 nm	6 nm
G1314A/B/C	1100 / 1200 / 1260	360.8nm 418.5nm	+/- 1 nm	6 nm
G1314D/E/F		418.5nm		
G4286..... 90A/B/C	1120 / 1220	536.4nm		
*) The variation in Measured Wavelength depends on the different Optical Bandwidth.				
May 19, 2010				
----- (Date)				
 ----- (R&D Manager)		 ----- (Quality Manager)		
P/N 89550-90501 		Revision: H Effective by: May 19, 2010		

Agilent Technologies on Internet

For the latest information on products and services visit our worldwide web site on the Internet at:

<http://www.agilent.com>

Select Products/Chemical Analysis

It will provide also the latest firmware of the modules for download.

Index

- configuration
 - one stack 12
- A**
- absorbance
 - Beer-Lambert 79
- active seal wash 51
- Agilent 1260 Infinity Quaternary LC VL
 - features 10
- Agilent
 - on internet 110
- algae 107
- alternative seal material 52
- analog out
 - put 45
- analog signal output 44
- analog output 40
- array
 - diode 29
- B**
- band width 6.5 nm 45
- battery
 - safety information 104
- beam splitter 35
- Beer-Lambert (law) 65
- Beer-Lambert
 - absorbance 79
- boards
 - photodiode boards (ADC) 35
- bypass 22
- C**
- choice of vials and caps 58
- communications 46
- composition precision 40
- composition range 40
- compressibility compensation 40, 52
- Configuration
 - two stack 15
- configuring
 - online plot 94
- control and data evaluation 43, 45
- cool-down time 41
- correction factors for flow cells 66, 80
- cutoff filter 34
- D**
- data evaluation and control 43
- data rate
 - sampling rate 45
- dead volume 41
- declaration of conformity 109
- delay volume 40, 62
- detection type 44
- detection
 - compound classes 74
- detector warm up 76
- dimension 39
- diode
 - width 43
- draw speed 58, 58
- DRAW 58
- drift (ASTM) and noise 43
- drift 45
- dual-piston in-series design 17
- E**
- eject speed 58, 58
- EJECT 58
- electronic waste 103
- entrance slit assembly 33
- extra-column volume
 - description 62
- F**
- features
 - GLP 41, 46
 - safety and maintenance 41, 46
 - safety and maintenance 44
- flow cell
 - max -light cartridge 28
 - solvent information 107
- flow accuracy 40
- flow cell
 - correction factors 66, 80
 - specifications 43
 - types and data 45
 - with RFID tag 32
- flow precision 40
- flow range 40
- G**
- GLP features 44
- gradient formation 40
- grating
 - assembly 35

Index

H

- holmium oxide
 - declaration of conformity 109
 - filter 34
- hydraulic system 40

I

- information
 - on UV-radiation 108
- injection volume precision 58
- injection volumes less than 2 µl 58
- injection sequence 22
- injection valve 19
- injection volumes 58
- Instant Pilot G4208A 30
- internet 110
- introduction to the autosampler 19
- introduction 30
 - to optical system 31

L

- lamp
 - type 44
 - uv 27
 - with RFID tag 33
- linear range 43
- linearity 45
 - specifications 47
- line
 - voltage and frequency 38
- lithium batteries 104
- loading
 - default 93
- low volume injections 58

M

- mainpass 22
- max-light cartridge

- flow cell 28
- metering device 58
- method
 - setting up 97
- mirror
 - assemblies 34
- multi-draw option 19

N

- negative absorbance 72
- network integration 90
- noise and drift (ASTM) 43
- Noise and Linearity
 - specifications 47, 48
- noise, short term 44

O

- online plot
 - configuring 94
- operating temperature 38
- operational hints, vacuum degasser 50
- operational pressure range 40
- optical unit
 - flow cell 32
- optical unit
 - beam splitter assembly 35
 - entrance slit assembly 33
 - filter assembly 34
 - filter 34
 - grating assembly 35
 - lamp 33
 - mirrors 34
 - photodiode assemblies 35
 - photodiode boards 35
 - source lens assembly 33
 - stepper motor 35
- optical 26
- optimization
 - detector performance 78

- detector performance 63
 - for sensitivity, selectivity, linearity, dispersion 65
 - how to get the best performance 63
 - margins for negative absorbance 72
 - of selectivity 73
 - overview 64
 - peak width 66
 - sample and reference
 - wavelength 68
 - spectra acquisition 72
 - stack configuration 12, 85
- optimizing the performance 61
- optimizing performance
 - automated needle wash 58
 - delay volume 58
 - delay-volume adjustment 58
 - inject-valve seal 58
 - low-volume capillary kit 58
 - maintenance 58
- optimizing
 - flow cell 65
- overview, pump 17
- overview
 - optical path 31
 - optical system 31
 - system overview 31

P

- peak width (response time) 66
- performance specifications
 - autosampler 42
- performance
 - optimization 63, 78
 - optimizing 61
 - specifications 43, 44
- pH range 40
- photodiode
 - assemblies 35
 - boards 35

Index

- photometric accuracy 66, 80
 - physical specifications
 - humidity 38
 - line voltage and frequency 38
 - operating temperature 38
 - safety information 38
 - piston chamber 17
 - power consumption 39
 - pressure pulsation 40, 52
 - pressure range 52
 - pressure, operating range 40
 - priming
 - with a syringe 50
 - with a pump 88
 - with the pump 50
 - programmable slit width 43
 - proportioning valve, high-speed 17
- ## R
- Radio Frequency Identification
 - flow cell and lamp 30
 - radio interference 105
 - recommended pH range 40
 - recyclable material 44
 - response time (peak width) 66
 - response time versus time constant 48
 - RFID
 - Radio Frequency Identification 30
- ## S
- safety class I 101
 - safety information
 - lithium batteries 104
 - safety
 - general information 101
 - symbols 100
 - sample and reference wavelength 68
 - sampling rate
 - data rate 45
 - sampling sequence 21
 - seal wash 17, 51
 - when to use 51
 - seal, alternative material 52
 - selectivity optimization 73
 - setable flow range 40
 - slit width 43
 - slit
 - fix 28
 - solvents 107
 - sound emission 106
 - source lens assembly 33
 - specifications
 - analog signal output 44
 - communications 44
 - control and data evaluation 43
 - diode width 43
 - flow cell 43
 - GLP features 44
 - linear range 43
 - noise and drift (ASTM) 43
 - noise and linearity 47, 48
 - performance 44
 - programmable slit width 43
 - safety and maintenance 44
 - signal data rate 43
 - spectra data rate 43
 - wavelength accuracy 43
 - wavelength bunching 43
 - wavelength range 43
 - spectra
 - acquisition 72
 - tools 45
 - standards 38
 - stepper motor 35
 - suppression
 - quantifying 73
 - system setup and installation
 - network Integration 90
 - optimizing stack configuration 12, 85
 - system 26
 - turning on 92
- ## T
- temperature control 45
 - temperature
 - range 41
 - time constant versus response time 48
 - transport mechanism 19
- ## U
- UV-radiation 108
- ## V
- vial racks 19
 - vials 19
 - viscous samples 58, 58
- ## W
- warm up of detector 76
 - warm-up time 41
 - waste
 - electrical and electronic equipment 103
 - wavelength
 - accuracy 43, 45
 - bunching 43
 - range 190-600 nm 44
 - range 43
 - WEEE directive 103
 - weight 39

www.agilent.com

In This Book

This manual contains technical reference information about the Agilent 1260 Infinity Quaternary LC VL.

The manual describes the following:

- introduction,
- product description,
- system optimization,
- setup and installation,
- quick start guide.

© Agilent Technologies 2010

Printed in Germany
06/2010



G1311-90310



Agilent Technologies