



# GENUINE PARTS

## INSTALLATION INSTRUCTIONS

<b>DESCRIPTION:</b>	Moonroof Wind Deflector
<b>APPLICATION:</b>	Rogue
<b>PART NUMBER:</b>	999D4 G2000

### KIT CONTENTS:

Item	Qty.	Part Description
A	1	Moonroof Deflector
B	4	Screw
C	4	Nylon Washer
D	4	Nylon Nut
E	8	Nylon Fastener
F	2	Side Bracket
G	2	Center Bracket
H	4	Protective Tape
I	1	Installation Instructions Replacement Template

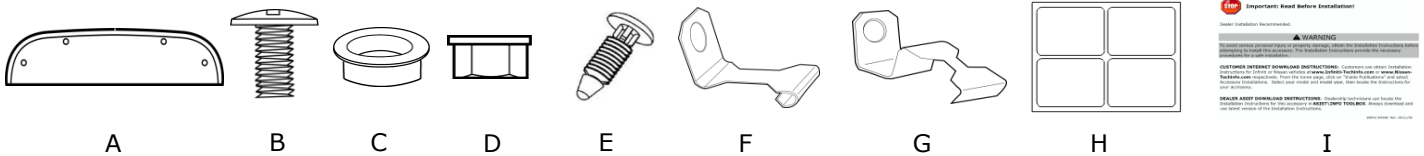

### TOOLS REQUIRED:

- Rubbing Alcohol (90% or greater)
- #2 Phillips Head Screw Driver
- Car Wash Supplies
- Measuring Tape or Scale
- Pen
- Masking Tape
- Towels
- 10mm Wrench

### PRE-INSTALLATION WARNINGS, CAUTIONS, CRITICAL STEPS, and NOTES:

- Dealer Installation Recommended. Instructions may refer to Service Manual.
- Clean moonroof deflector with a mild dishwashing soap and water solution and a soft cloth or chamois.
- To avoid surface damage, never use ammonia-based solutions to clean your moonroof deflector.
- To remove fine scratches and restore the original luster, use a high quality plastic cleaner.

### **WARNING**

- **Some plastic surfaces may become damaged by alcohol solution. If alcohol does come into contact with plastic surface immediately wash surface with water.**
- **Failure to clean mounting surface properly may cause tape to have poor adhesion to vehicle.**
- **If vehicle has been recently painted, allow paint to dry and age 24 hours before installing deflector.**
- **Install deflector when ambient temperature is above 15 C (60 F).**
- **Do not wash or expose vehicle to a wet environment for 24 hrs. after installing deflector.**
- **Please use proper pressure of 103kpa (15psi) applied with a dry, soft, clean rag to adhere deflector tape.**

## INSTALLATION PROCEDURE:

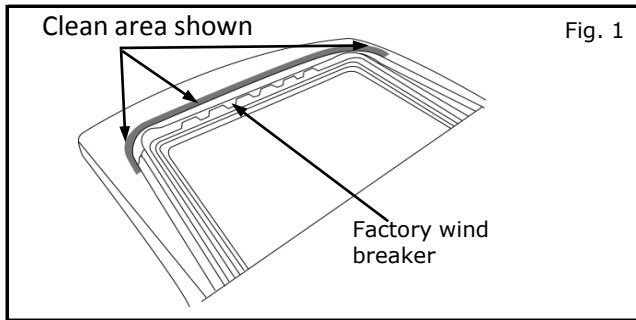

- 1) Open moonroof.
- 2) Clean roof installation area. (use automotive safe soap)
- 3) Clean inner edge (flange) of moonroof opening using rubbing alcohol and towel.

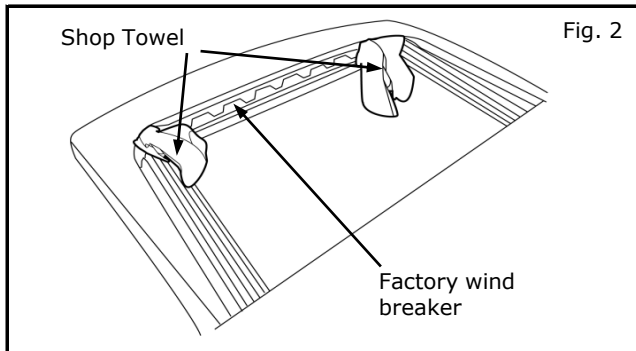

- 4) Push factory wind breaker down and insert towels to hold it in place.

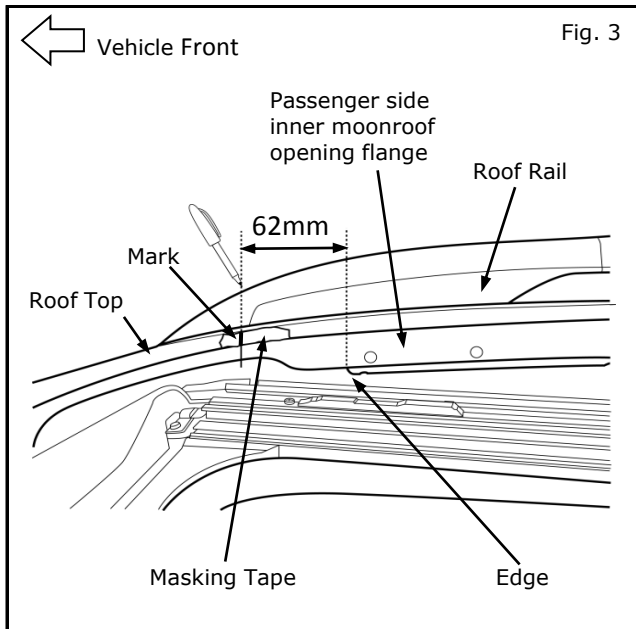

- 5) Place masking tape on vehicle roof top as shown.
- 6) Measure 62mm forward from edge shown on passenger side inner moonroof opening flange and mark a line on masking tape with pen.
- 7) Repeat steps 5 and 6 for driver side.

**INSTALLATION PROCEDURE:**

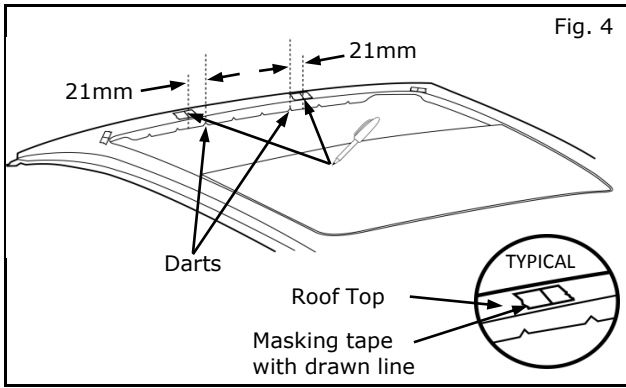

- 8) Place masking tape on vehicle roof top as shown.
- 9) Referenceing the 3rd and 6th darts, measure outboard 21mm from each and draw a line on masking tape using pen.

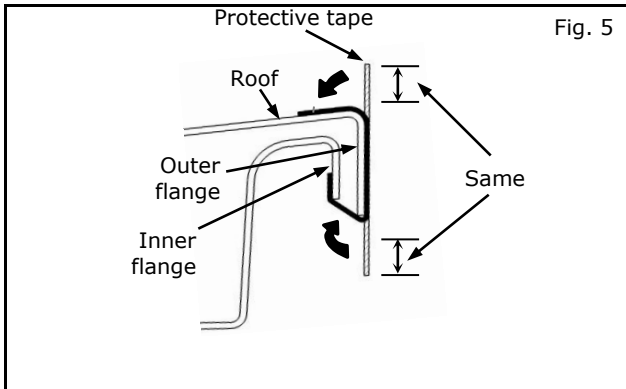

- 10) Peel protective tape from backing and locate evenly spaced as shown at final (4) locations.
- 11) Remove masking tape.
- 12) Wrap protective tape under lip and on top surface of roof.

**NOTE:**  
**Make sure protective tape is smooth and free of wrinkles.**

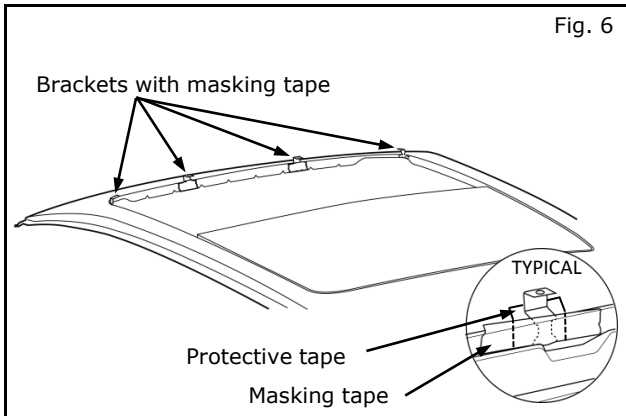

- 13) Center brackets on protective tape and secure in place with masking tape.

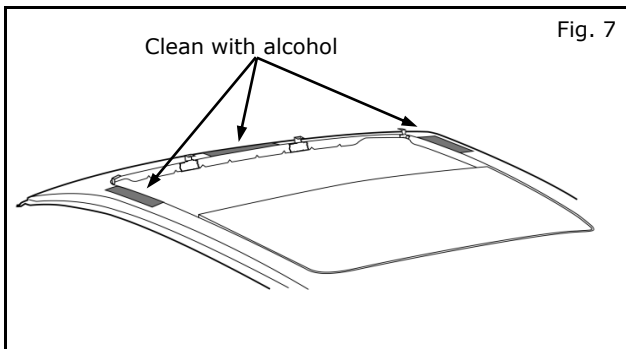

- 14) Clean areas shown using rubbing alcohol (90% or greater).  
**NOTE:**  
**Allow enough time for alcohol to evaporate.**

## INSTALLATION PROCEDURE:

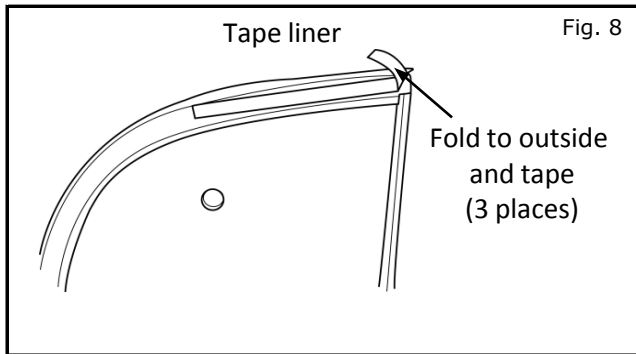

- 15) Fold tape liner pull tabs to outside of deflector and tape in place using masking tape.

**NOTE:**

**Ensure that adhesive tape under liner is not yet exposed.**

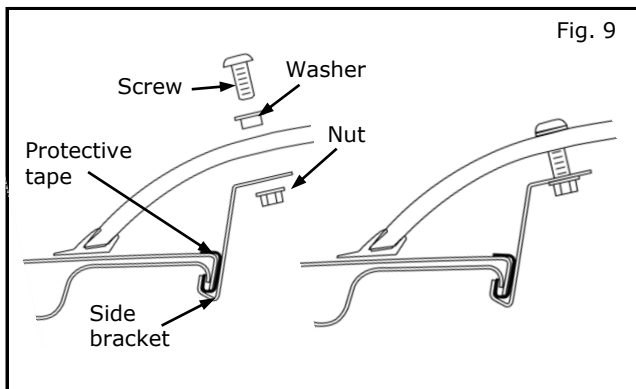

- 16) Set deflector on roof and align deflector holes with bracket holes.

- 17) Starting with side brackets, install washer and screw through deflector and bracket. Gently push down on deflector and loosely install nut.

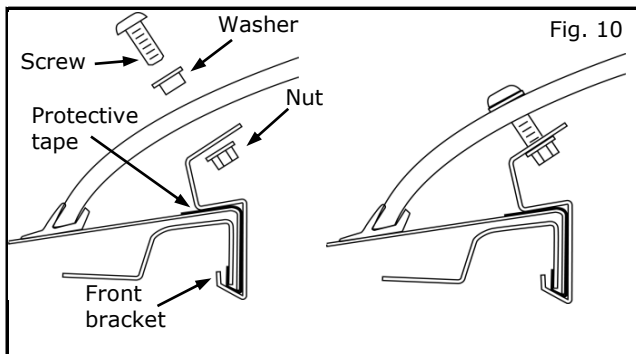

- 18) Repeat step 16 for center brackets.

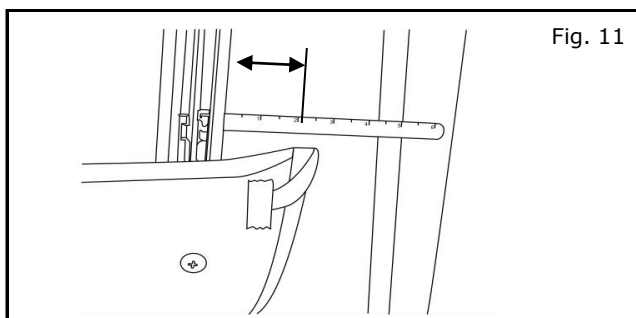

- 19) Remove masking tape from brackets and discard.

- 20) Verify with scale that deflector is located evenly on both sides of opening.

**NOTE:**

**Ensure both sides are evenly spaced.**

## INSTALLATION PROCEDURE:

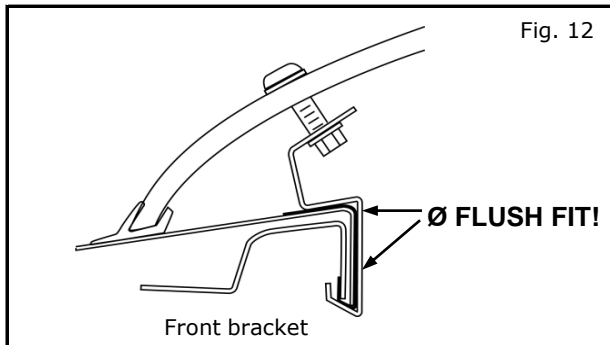

- 21) Push forward to eliminate any gap between bracket and flange.

### **⚠ CAUTION**

**Leaving air gap between brackets and flange can cause wind noise issues. Confirm there is no gap between brackets and flange. If there is any gap, adjust deflector and side brackets forward to eliminate gap.**

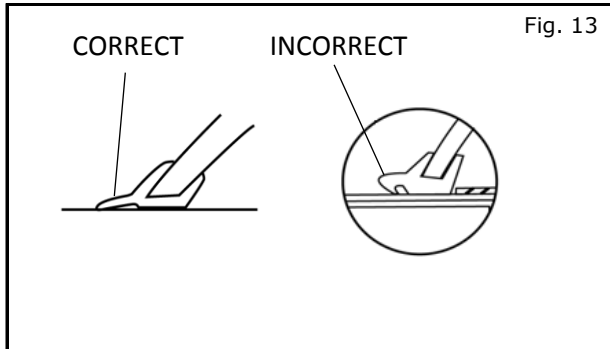

- 22) Check that rubber seal is not twisted or rolled under deflector. If necessary, slide a credit card under rubber seal to seat it correctly against roof.

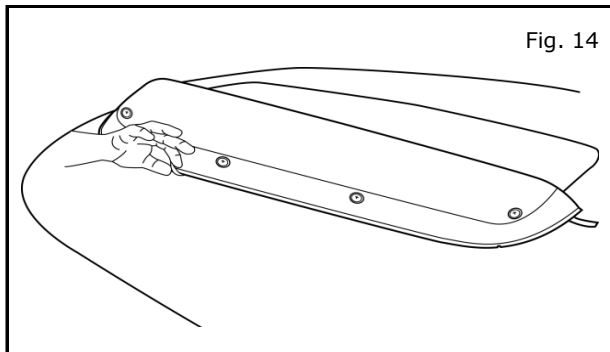

- 23) Pull tape liner of center tape.

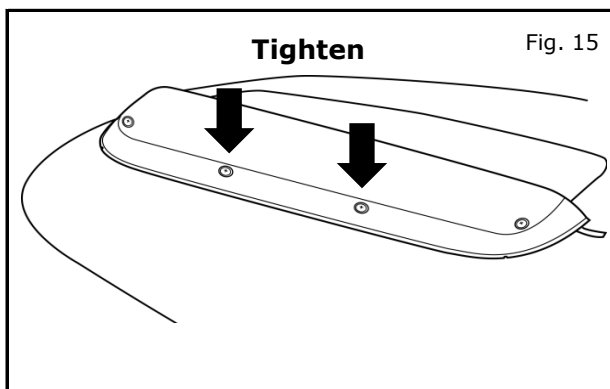

- 24) Fully tighten front bracket screws.

**NOTE:**

**To prevent damage to nylon nuts, do not overtighten.**

## INSTALLATION PROCEDURE:

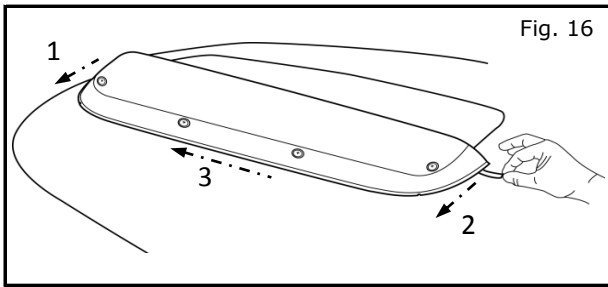

- 25) Carefully lift rear of moonroof deflector and pull out tape liners at both sides.

**NOTE:**

**Take care not to cause any gaps between brackets and roof flange.**

- 26) Using micro fiber cloth, apply 15lbs of pressure on deflector to adhere deflector to roof. Pressure must be applied to sides and front of deflector where tape liner was removed in locations 1, 2 and 3 as shown.

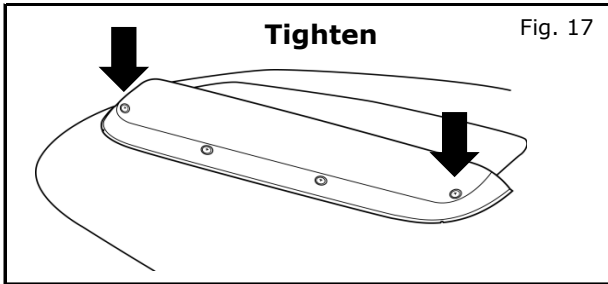

- 27) Fully tighten side bracket screws.

**NOTE:**

**To prevent damage to nylon nuts, do not overtighten.**

- 28) Remove towels holding factory wind breaker down and close moonroof.

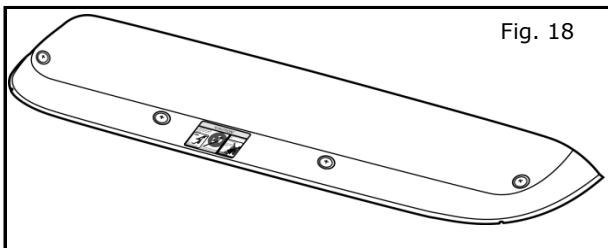

- 29) Peel off and discard "Caution Label" attached to top surface of deflector.

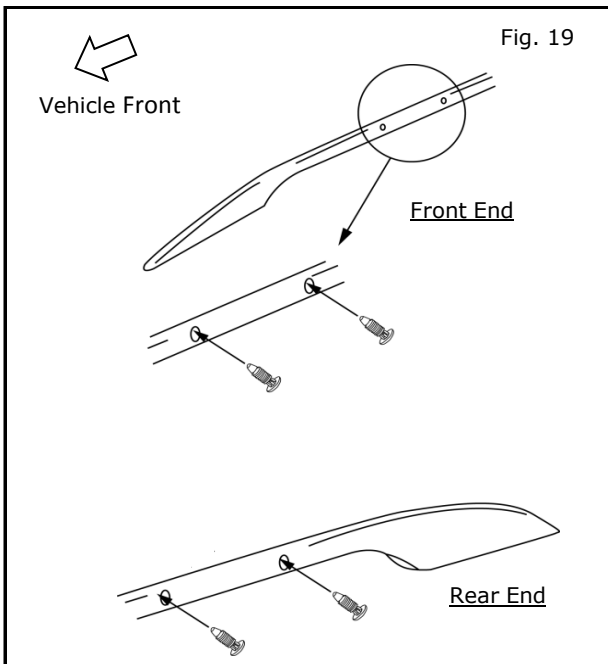

- 30) Install (8) Nylon Fasteners into roof rail holes (passenger side shown). Ensure fastener is flush to roof rail surface.

**NOTE:**

**If vehicle has cross bars installed, discard Nylon Fasteners or keep for future use if cross bars will be removed.**

**INSTALLATION PROCEDURE:**

**FINAL INSPECTION:**

Verify rubber seal is not rolled under deflector.

Verify moonroof closes normally.