

“A” & “A-2” Plug-In Motor Start Relay 12-862203-000

Packaging

- (1) 12-862203-000 Plug-In Motor Start Relay Package, contains:
 - (1) 11-696644-000 Relay
 - (1) 11-696645-000 Relay Base
 - (2) 11-696684-000 Relay Clips
 - (2) #6-32 x 5/8” Pan Head Screw
 - (2) 11-176005-001 Keps Nut
- (10) Fork Terminals

Instructions for “A” Pinsetter



WARNING! Remove power to the pinsetter by turning off the circuit breaker and unplugging the main power cord to the electrical box.

Please refer to the wiring schematic in the *Automatic Pinsetter Service Manual* P/N 12-900900-000, (Figures 53-54) for wire locations to the original motor start relay. Additionally attached is a simplified wiring diagram to assist with installation.

The original motor start relay shown on the wiring diagram in the service manual will be labeled with contact locations A,B,C,D,E,F and two coil wire locations. The new Motor Start Relay base will be labeled 1,2,3,4,5,6,7,8,9,10,11.

1. Remove the relay (P/N 11-696644-000) from the relay base (P/N 11-696645-000). Refer to *Figure 1*.

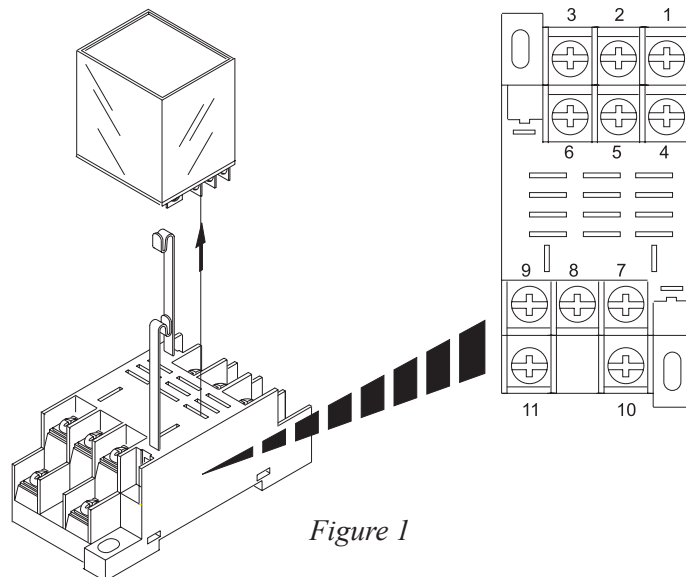

Figure 1

2. In the electrical box, remove the screw from the bottom of the box that is securing the original motor start relay. Do not remove any of the wires that are soldered to the relay at this time.
3. On page 2, match the appropriate wiring chart with electrical box. Follow the steps provided in the chart to transfer the wires from the existing relay to the new relay base. See page 3 for simplified wiring diagram.

"A" Wire Transfer Guide

i **NOTE:** When removing wires from the original motor start relay, verify wires have enough length to connect to the new relay base. Remove the wire from the old relay terminal and prepare the end to be fitted with the crimp-on fork terminals provided in the kit. Due to previous maintenance in the electrical box it is common for the wires to vary in length from the original equipment. If the existing wires are not long enough, lengthen by splicing in a suitable extension of stranded 18 gauge machine tool wire, connected with any common insulated crimp-on 18 gauge splice connector.

"A" Standard Electrical Box with Allen Bradley or Federal Pacific Motor Contactor

Start	Remove Wire	Wire ID	Old Relay RL2 Terminals	New Relay Base Terminals	Other End of Wire
Step 1:	Remove Wire	n/a	from A	install on 9	the other end of the wire should be at TS2-1 Low Voltage Terminal Strip
Step 2:	Remove Wire	n/a	from B	install on 6	the other end of the wire should be at TS2-6 Low Voltage Terminal Strip
Step 3:	Remove Wire	n/a	from C	install on 8	the other end of the wire should be at n/a One of Two Motor Contactor Coil Terminals
Step 4:	Remove Wire	n/a	from D	install on 5	the other end of the wire should be at TS1-B High Voltage Terminal Strip
Step 5:	Remove Wire	n/a	from E	install on 7	the other end of the wire should be at n/a Two of Two Motor Contactor Coil Terminals
Step 6:	Remove Wire	n/a	from F	install on 4	the other end of the wire should be at TS1-H High Voltage Terminal Strip
Step 7:	Remove Wire	n/a	from Coil	install on 10	the other end of the wire should be at C Manager Control Cannon Plug
Step 8:	Remove Wire	n/a	from Coil	install on 11	the other end of the wire should be at TS2-9 Low Voltage Terminal Strip

"A" Standard Electrical Box with Deltrol Motor Contactor

Start	Remove Wire	Wire ID	Old Relay RL2 Terminals	New Relay Base Terminals	Other End of Wire
Step 1:	Remove Wire	n/a	from A	install on 9	the other end of the wire should be at TS2-1 Low Voltage Terminal Strip
Step 2:	Remove Wire	n/a	from B	install on 6	the other end of the wire should be at TS2-6 Low Voltage Terminal Strip
Step 3:	Remove Wire	n/a	from C	install on 8	the other end of the wire should be at n/a One of Two Motor Contactor Coil Terminals
Step 4:	Remove Wire	n/a	from D	install on 5	the other end of the wire should be at TS1-B High Voltage Terminal Strip
Step 5:	Remove Wire	n/a	from Coil	install on 10	the other end of the wire should be at C Manager Control Cannon Plug
Step 6:	Remove Wire	n/a	from Coil	install on 11	the other end of the wire should be at TS2-9 Low Voltage Terminal Strip

**“A” STANDARD ELECTRICAL BOX WITH ALLEN
BRADLEY OR FEDERAL PACIFIC MOTOR
CONTACTOR DIAGRAM**

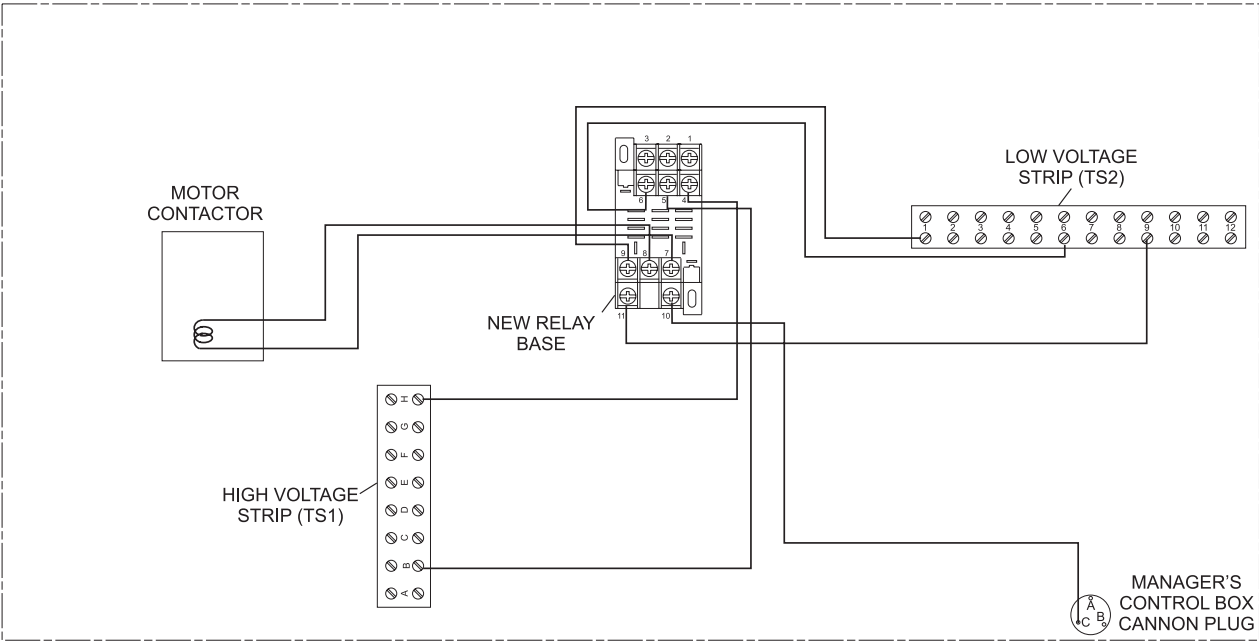

**“A” STANDARD ELECTRICAL BOX WITH DELTROL MOTOR
CONTACTOR DIAGRAM**

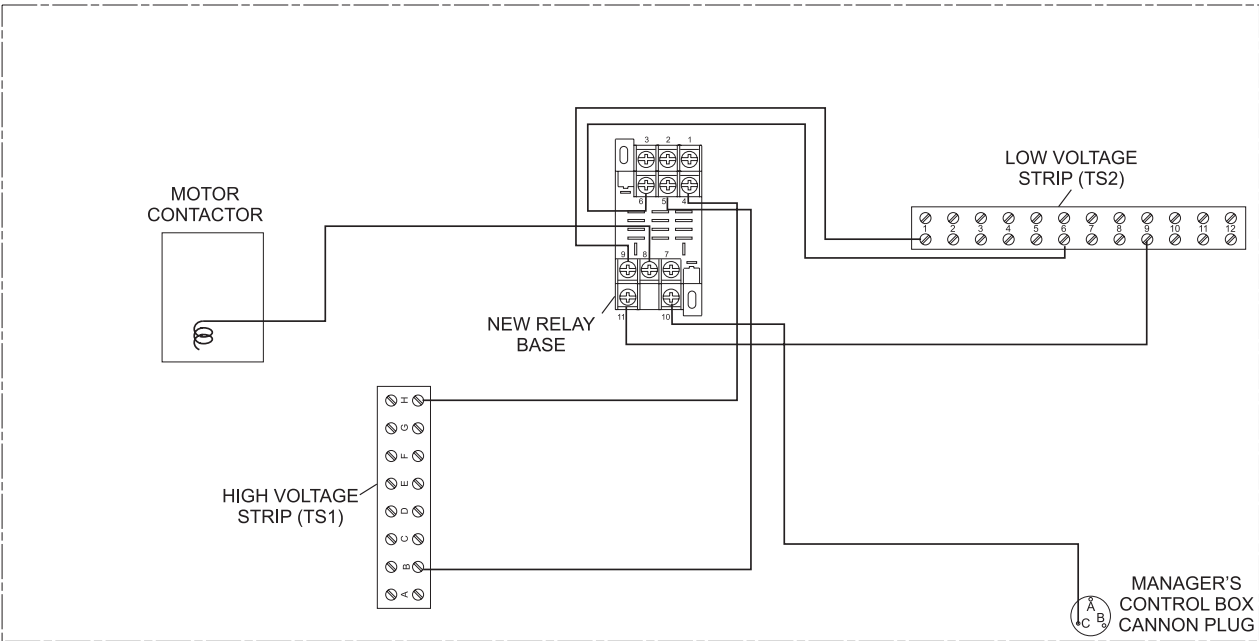

- Determine a suitable location for the new relay base (P/N 11-696645-000) in the electrical box. Electrical components can vary in location within each box, it is important the base and wires do not interfere with other components, and the location allows for easy access to the new relay. Refer to *Figure 2* for optional location.

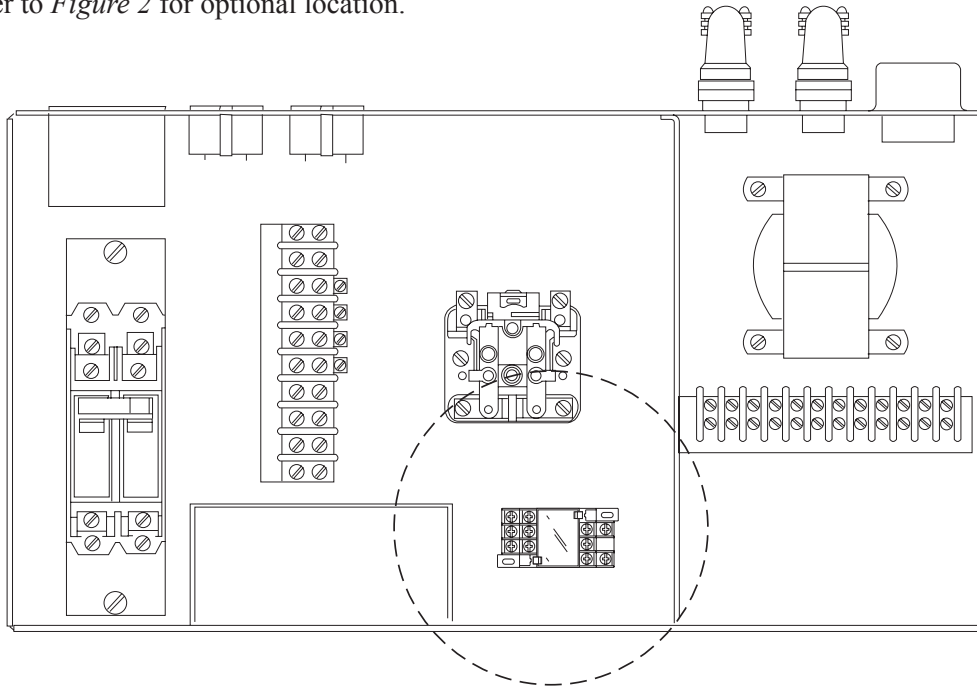

Figure 2.

- Once a suitable location is determined, mark the screw holes onto the box. Drill the holes for the #6-32 x 5/8 pan head screws. Install the base into the box utilizing the (2) #6-32 x 5/8 pan head screws and (2) 11-176005-001 keps nuts.
- Insert 11-696644-000 relay into base and secure the clips over the top of the relay. Refer to *Figure 3*.

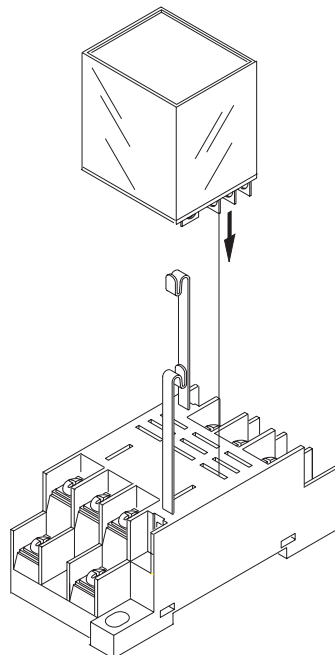

Figure 3

Instructions for “A-2” Pinsetter



WARNING! Remove power to the pinsetter by turning off the circuit breaker and unplugging the main power cord to the electrical box.

Please refer to the wiring schematics in the *Automatic Pinsetter Service Manual* P/N 12-752828-000, (Figures I-85 through I-91) for wire locations to the original motor start relay. Additionally attached is a simplified wiring diagram to assist with installation.

The original motor start relay will be labeled with contact locations A,B, E,F and two coil wire locations G and H. The new Motor Start Relay base will be labeled with contact locations 1,2,3,4,5,6,7,8,9,10,11.

1. Remove the relay (P/N 11-696644-000) from the relay base (P/N 11-696645-000). Refer to *Figure 4*.

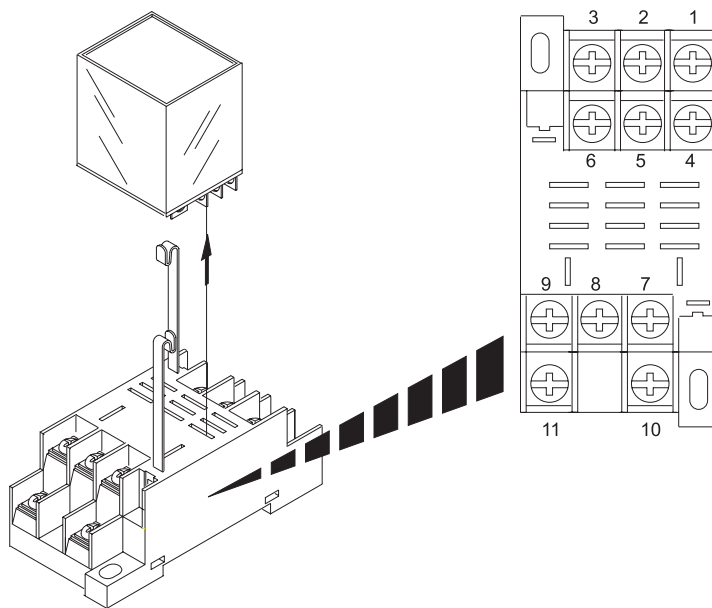

Figure 4

2. In the electrical box, remove the screw from the bottom of the box that is securing the original motor start relay. Do not remove any of the wires that are soldered to the relay at this time.
3. On page 6, match the appropriate wiring chart with electrical box. Follow the steps provided in the chart to transfer the wires from the existing relay to the new relay base. See page 7 for simplified wiring diagram.

"A-2" Wire Transfer Guide

i **NOTE:** When removing wires from the original motor start relay, verify wires have enough length to connect to the new relay base. Remove the wire from the old relay terminal and prepare the end to be fitted with the crimp-on fork terminals provided in the kit. Due to previous maintenance in the electrical box it is common for the wires to vary in length from the original equipment. If the existing wires are not long enough, lengthen by splicing in a suitable extension of stranded 18 gauge machine tool wire, connected with any common insulated crimp-on 18 gauge splice connector.

"A-2" Standard Electrical Box

Start	Wire ID	Wire ID	Old Relay RL2 Terminals	New Relay Base Terminals	Other End of Wire
Step 1:	Remove Wire	41	from A	install on 6	the other end of the wire should be at TS2-1 Low Voltage Terminal Strip
Step 2:	Remove Wire	16	from B	install on 9	the other end of the wire should be at TS2-9 Low Voltage Terminal Strip
Step 3:	Remove Wire	33	from E	install on 7	the other end of the wire should be at RL3-6 Motor Contactor Coil
Step 4:	Remove Wire	7	from F	install on 4	the other end of the wire should be at TS1-H High Voltage Terminal Strip
Step 5:	Remove Wire	18	from G coil	install on 10	the other end of the wire should be at CN3-C Manager Control Cannon Plug
Step 6:	Remove Wire	35	from G coil	install on 10	the other end of the wire should be at CN1-B Ball Lift Cannon Plug
Step 7:	Remove Wire	12	from H coil	install on 11	the other end of the wire should be at TS2-9 Low Voltage Terminal Strip
Step 8	Remove Wire	54	from H coil	install on 11	the other end of the wire should be at TD1-14 Terminal 14 of Time Delay

"A-2" Universal Electrical Box

Start	Wire ID	Wire ID	Old Relay RL2 Terminals	New Relay Base Terminals	Other End of Wire
Step 1:	Remove Wire	41	from A	install on 6	the other end of the wire should be at TS2-1 Low Voltage Terminal Strip
Step 2:	Remove Wire	16	from B	install on 9	the other end of the wire should be at TS2-9 Low Voltage Terminal Strip
Step 3:	Remove Wire	33	from E	install on 7	the other end of the wire should be at RL3-6 Motor Contactor Coil
Step 4:	Remove Wire	7	from F	install on 4	the other end of the wire should be at TS1-E High Voltage Terminal Strip
Step 5:	Remove Wire	19	from G coil	install on 10	the other end of the wire should be at SW1-2 On/Off Switch
Step 6:	Remove Wire	36	from G coil	install on 10	the other end of the wire should be at CN1-A Ball Lift Cannon Plug
Step 7:	Remove Wire	12	from H coil	install on 11	the other end of the wire should be at TS2-9 Low Voltage Terminal Strip
Step 8	Remove Wire	54	from H coil	install on 11	the other end of the wire should be at TD1-14 Terminal 14 of Time Delay

"A2" STANDARD ELECTRICAL BOX DIAGRAM

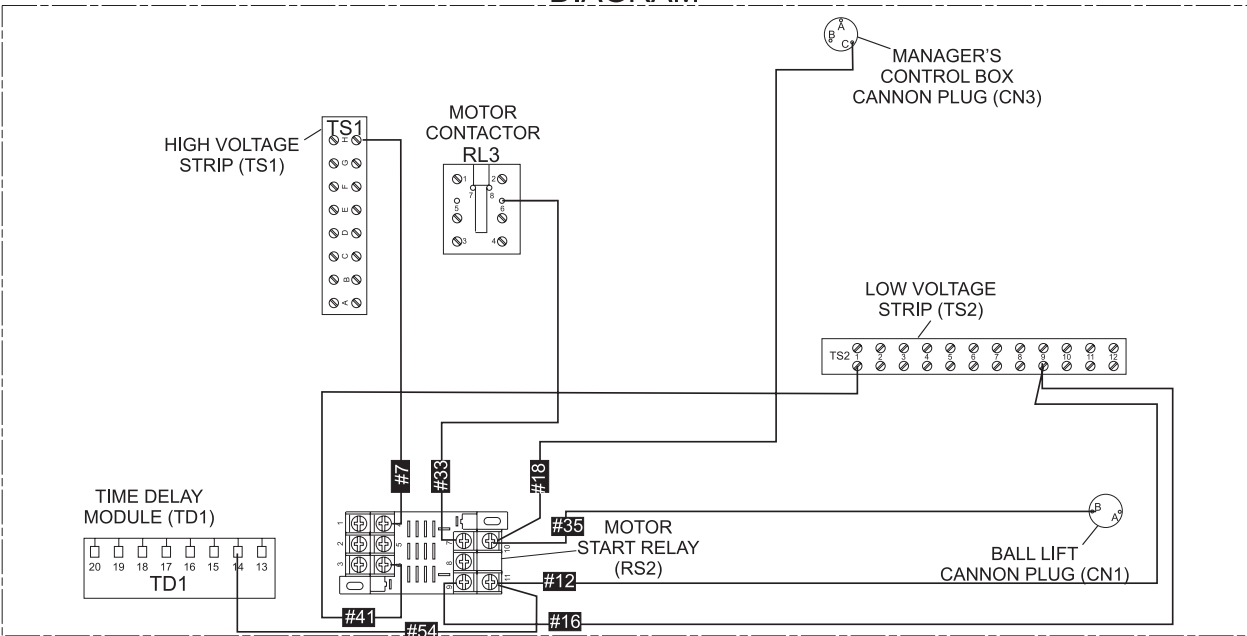

"A2" UNIVERSAL ELECTRICAL BOX DIAGRAM

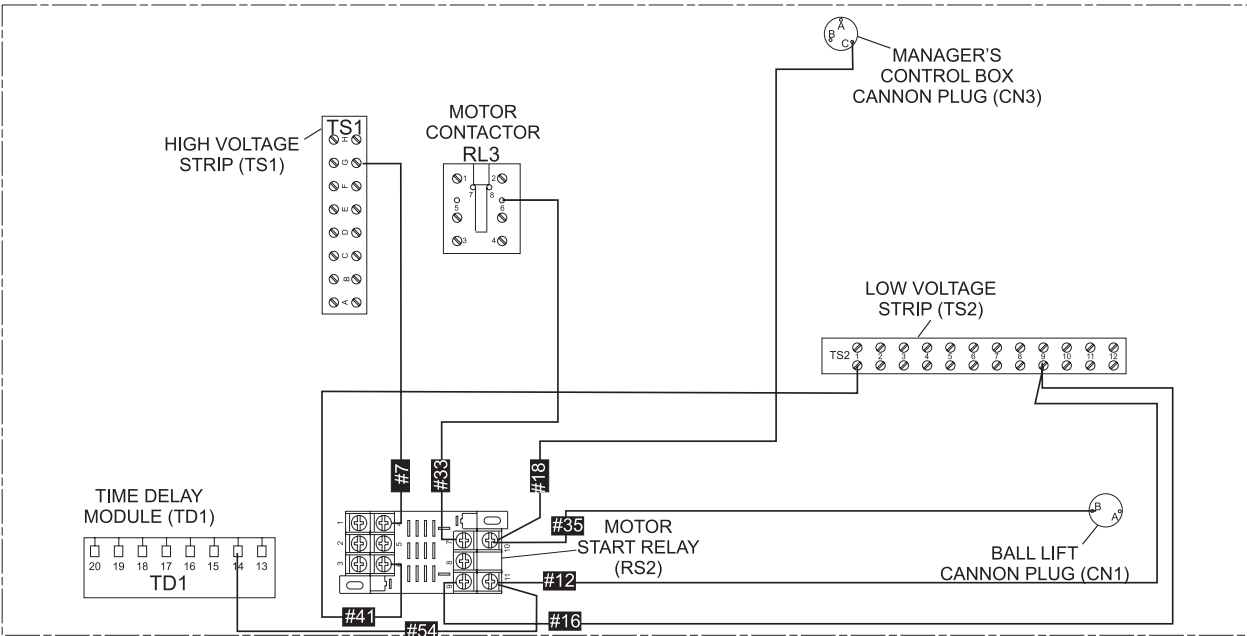

- Determine a suitable location for relay base in the electrical box. Electrical components will vary in location within each box, it is important the base and wires do not interfere with other components, and the location allows for easy access to the new relay. Refer to *Figure 5* for optional location.

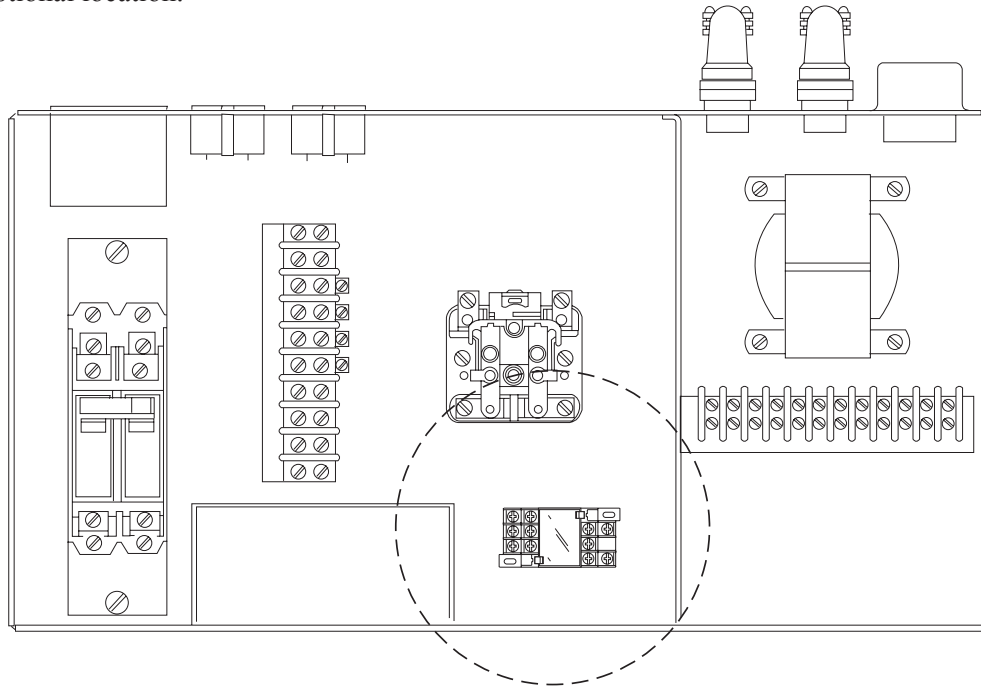

Figure 5

- Once a suitable location is determined, mark the screw holes onto the box. Drill the holes for the #6-32 x 5/8 pan head screws. Install the base into the box utilizing the (2) #6-32 x 5/8 pan head screws and (2) 11-176005-001 keps nuts.
- Insert 11-696644-000 relay into base and secure the clips over the top of the relay. Refer to *Figure 6*.

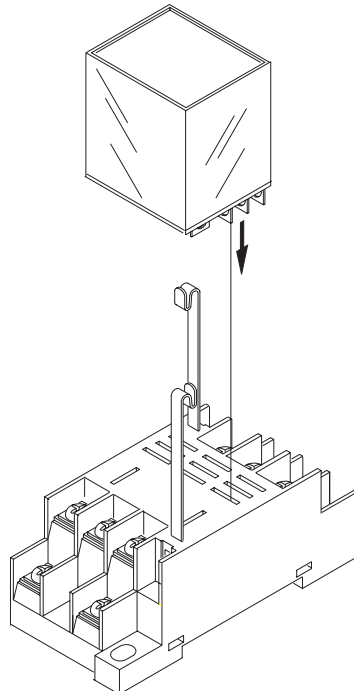

Figure 6