

TCA090/150 SERIES

The TCA 7.5, 8.5 and 10 ton cooling package units are available in standard efficiency (090S, 102S, 120S) and high efficiency (090H, 102H, 120H). The TCA 12.5 ton unit is available in standard efficiency only (150S). The TCA 090/150 series uses one cabinet size with cooling capacities of 93,000 to 140,000 Btuh (27.2 to 41 kW).

Optional electric heat is factory-or field-installed in TCA units. Electric heat operates in single or multiple stages depending on the kW input size. 7.5 kW to 45 kW heat sections are available for the TCA090 and 102 and 15 kW to 60 kW heat sections are available for the TCA120 and 150.

All units utilize two scroll compressors and are designed to accept any of several different energy management thermostat control systems with minimum field wiring. Factory or field provided control options connect to the unit with jack plugs. When "plugged in" the controls become an integral part of the unit wiring.

Information contained in this manual is intended for use by qualified service technicians only. All specifications are subject to change. Procedures outlined in this manual are presented as a recommendation only and do not supersede or replace local or state codes.

If the unit must be lifted for service, rig unit by attaching four cables to the holes located in the unit base rail (two holes at each corner). Refer to the installation instructions for the proper rigging technique.

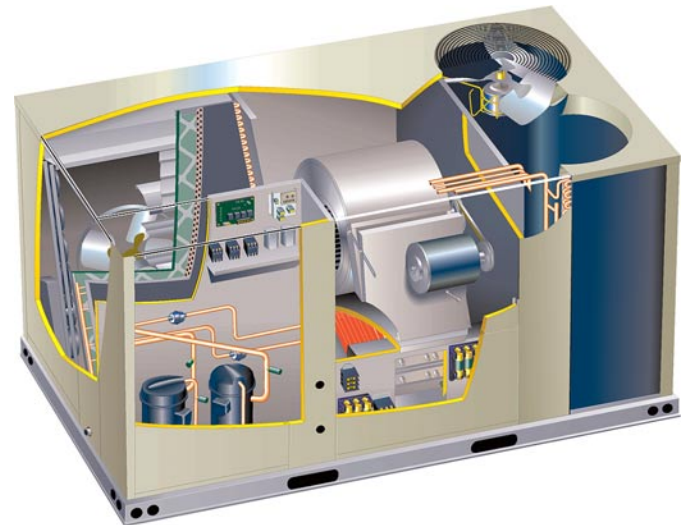

**ELECTROSTATIC DISCHARGE (ESD)
Precautions and Procedures**

⚠ CAUTION

Electrostatic discharge can affect electronic components. Take precautions during unit installation and service to protect the unit's electronic controls. Precautions will help to avoid control exposure to electrostatic discharge by putting the unit, the control and the technician at the same electrostatic potential. Neutralize electrostatic charge by touching hand and all tools on an unpainted unit surface before performing any service procedure.

⚠ WARNING

Improper installation, adjustment, alteration, service or maintenance can cause property damage, personal injury or loss of life. Installation and service must be performed by a qualified installer or service agency.

⚠ WARNING

Refrigerant can be harmful if it is inhaled. Refrigerant must be used and recovered responsibly. Failure to follow this warning may result in personal injury or death.

Table of Contents

Specifications	2
Options	4
Electrical Data	6
Blower Data	8
I Unit Components	12
II Placement and Installation	24
III Start Up Operation	24
IV Charging	24
V Maintenance	26
VI Accessories	27
VII Wiring and Operating Sequence	33

SPECIFICATIONS

General Data		Nominal Tonnage	7.5 Ton	8.5 Ton	10 Ton	12.5 Ton
	Model No.		TCA090S2B	TCA102S2B	TCA120S2B	TCA150S2B
	Efficiency Type		Standard	Standard	Standard	Standard
Cooling Performance	Gross Cooling Capacity - Btuh (kW)		93,000 (27.2)	104,000 (30.5)	126,000 (36.6)	145,000 (42.5)
	¹ Net Cooling Capacity - Btuh (kW)		90,000 (26.4)	100,000 (29.3)	120,000 (35.2)	138,000 (40.4)
	ARI Rated Airflow - cfm (L/s)		3000 (1415)	3400 (1605)	3800 (1795)	4250 (2005)
	Total Unit Power (kW)		8.9	9.9	11.8	14.5
	¹ EER (Btuh/Watt)		10.1	10.1	10.1	9.5
	² Integrated Part Load Value (Btuh/Watt)		10.5	10.5	10.5	9.2
Refrigerant Charge Furnished (HCFC-22)	Circuit 1	7 lbs. 0 oz. (3.18 kg)	7 lbs. 8 oz. (3.140 kg)	10 lbs. 0 oz. (4.53 kg)	13 lbs. 0 oz. (5.90 kg)	
	Circuit 2	6 lbs. 8 oz. (2.95 kg)	7 lbs. 0 oz. (3.18 kg)	10 lbs. 0 oz. (4.53 kg)	12 lbs. 0 oz. (5.44 kg)	
³ Sound Rating Number (dB)			88	88	88	88
Compressor - Number & Type			(2) Scroll	(2) Scroll	(2) Scroll	(2) Scroll
Condenser Coil	Net face area - sq. ft. (m ²)	29.3 (2.72) total	29.3 (2.72) total	29.3 (2.72) total	26.6 (2.47) total	
	Tube diameter - in. (mm)	3/8 (9.5)	3/8 (9.5)	3/8 (9.5)	3/8 (9.5)	
	Number of rows	1	1	2	3	
	Fins per inch (m)	20 (787)	20 (787)	20 (787)	20 (787)	
Condenser Fans	Motor horsepower (W)	(2) 1/3 (249)	(2) 1/3 (249)	(2) 1/3 (249)	(2) 1/2 (372)	
	Motor rpm	1075	1075	1075	1075	
	Total Motor watts	700	700	700	1150	
	Diameter - in. (mm) - no. of blades	(2) 24 (610) - 3	(2) 24 (610) - 3	(2) 24 (610) - 3	(2) 24 (610) - 3	
	Total air volume - cfm (L/s)	8,000 (3775)	8,000 (3775)	8,000 (3775)	9,000 (4245)	
Evaporator Coil	Net face area - sq. ft. (m ²)	10.5 (0.98) total	10.5 (0.98) total	10.5 (0.98) total	10.5 (0.98) total	
	Tube diameter - in. (mm)	3/8 (9.5)	3/8 (9.5)	3/8 (9.5)	3/8 (9.5)	
	Number of rows	3	3	4	4	
	Fins per inch (m)	14 (551)	14 (551)	14 (551)	14 (551)	
	Drain Connection - no. & size	(1) 1 in. NPT coupling	(1) 1 in. NPT coupling	(1) 1 in. NPT coupling	(1) 1 in. NPT coupling	
	Expansion device type	Balanced Port Thermostatic Expansion Valve, removable power head				
Standard Indoor Blower and Drive	⁴ Belt Drive - Nominal motor output	2 hp (1.5 kW)	2 hp (1.5 kW)	3 hp (2.2 kW)	5 hp (3.7 kW)	
	Maximum usable output (US Only)	2.3 hp (1.7 kW)	2.3 hp (1.7 kW)	3.45 hp (2.6 kW)	5.75 hp (4.3 kW)	
	Drive kit	kit #1 - 680 - 925 rpm	kit #1 - 680 - 925 rpm	kit #3 - 895 - 1120 rpm	kit #6 - 1100- 1395 rpm	
	Wheel nominal diameter x width - in. (mm)	(1) 15 x 15 (381 x 381)	(1) 15 x 15 (381 x 381)	(1) 15 x 15 (381 x 381)	(1) 15 x 15 (381 x 381)	
Filters	Type of filter	Disposable, pleated MERV 7 (standard) or MERV 11 (optional)				
	Number and size - in. (mm)	(4) 18 x 24 x 2 (457 x 610 x 51)	(4) 18 x 24 x 2 (457 x 610 x 51)	(4) 18 x 24 x 2 (457 x 610 x 51)	(4) 18 x 24 x 2 (457 x 610 x 51)	
Electrical characteristics		208/230V, 460V or 575V - 60 hertz - 3 phase				

NOTE - Net capacity includes evaporator blower motor heat deduction. Gross capacity does not include evaporator blower motor heat deduction.

¹ Certified in accordance with the ULE certification program, which is based on ARI Standard 340/360, 95°F (35°C) outdoor air temperature and 80°F (27°C) db/67°F (19°C) wb entering evaporator air; minimum external duct static pressure.

² Integrated Part Load Value rated at 80°F (27°C) outdoor air temperature, 80°F (27°C) db/67°F (19°C) wb indoor air temperature.

³ Sound Rating Number rated in accordance with test conditions included in ARI Standard 270.

⁴ Maximum usable output of motors furnished by Lennox are shown. In Canada, nominal motor output is also maximum usable motor output. If motors of comparable output are used, be sure to keep within the service factor limitations outlined on the motor nameplate.

SPECIFICATIONS

General Data		Nominal Tonnage Model No.	7.5 Ton TCA090H2B	8.5 Ton TCA102H2B	10 Ton TCA120H2B
Cooling Performance	Gross Cooling Capacity - Btuh (kW)		93,000 (27.2)	106,000 (31.0)	126,000 (36.9)
	¹ Net Cooling Capacity - Btuh (kW)		90,000 (26.4)	103,000 (30.2)	120,000 (35.2)
	ARI Rated Airflow - cfm (L/s)		3000 (1415)	3400 (1605)	3800 (1795)
	Total Unit Power (kW)		8.0	9.2	10.9
	¹ EER (Btuh/Watt)		11.0	11.0	11.0
	² Integrated Part Load Value (Btuh/Watt)		11.4	11.4	11.4
Refrigerant Charge Furnished (HCFC-22)	Circuit 1		8 lbs. 8 oz. (3.86 kg)	8 lbs. 8 oz. (3.86 kg)	10 lbs. 0 oz. (4.54 kg)
	Circuit 2		8 lbs. 8 oz. (3.86 kg)	8 lbs. 8 oz. (3.86 kg)	10 lbs. 0 oz. (4.54 kg)
³ Sound Rating Number (dB)			88	88	88
Compressor - Number and Type			(2) Scroll	(2) Scroll	(2) Scroll
Condenser Coil	Net face area - sq. ft. (m ²)		29.3 (2.72) total	29.3 (2.72) total	29.3 (2.72) total
	Tube diameter - in. (mm)		3/8 (9.5)	3/8 (9.5)	3/8 (9.5)
	Number of rows		2	2	2
	Fins per inch (m)		20 (787)	20 (787)	20 (787)
Condenser Fans	Motor horsepower (W)		(2) 1/3 (249)	(2) 1/3 (249)	(2) 1/3 (249)
	Motor rpm		1075	1075	1075
	Total Motor watts		700	700	700
	Diameter - in. (mm) - no. of blades		(2) 24 (610) - 3	(2) 24 (610) - 3	(2) 24 (610) - 3
	Total air volume - cfm (L/s)		8,000 (3775)	8,000 (3775)	8,000 (3775)
Evaporator Coil	Net face area - sq. ft. (m ²)		10.5 (0.98) total	10.5 (0.98) total	10.5 (0.98) total
	Tube diameter - in. (mm)		3/8 (9.5)	3/8 (9.5)	3/8 (9.5)
	Number of rows		3	3	4
	Fins per inch (m)		14 (551)	14 (551)	14 (551)
	Drain Connection - no. & size		(1) 1 in. NPT coupling	(1) 1 in. NPT coupling	(1) 1 in. NPT coupling
	Expansion device type		Balanced Port Thermostatic Expansion Valve, removable power head		
Standard Indoor Blower and Drive	⁴ Belt Drive - Nominal motor output		2 hp (1.5 kW)	2 hp (1.5 kW)	3 hp (2.2 kW)
	Maximum usable output (US Only)		2.3 hp (1.7 kW)	2.3 hp (1.7 kW)	3.45 hp (2.6 kW)
	Motor - Drive kit		kit #1 - 680 - 925 rpm	kit #1 - 680 - 925 rpm	kit #3 - 895 - 1120 rpm
	Wheel nominal diameter x width - in. (mm)		(1) 15 x 15 (381 x 381)	(1) 15 x 15 (381 x 381)	(1) 15 x 15 (381 x 381)
Filters	Type of filter		Disposable, pleated MERV 7 (standard) or MERV 11 (optional)		
	Number and size - in. (mm)		(4) 18 x 24 x 2 (457 x 610 x 51)	(4) 18 x 24 x 2 (457 x 610 x 51)	(4) 18 x 24 x 2 (457 x 610 x 51)
Electrical characteristics			208/230V, 460V or 575V - 60 hertz - 3 phase		

NOTE - Net capacity includes evaporator blower motor heat deduction. Gross capacity does not include evaporator blower motor heat deduction.

¹ Certified in accordance with the ULE certification program, which is based on ARI Standard 340/360, 95°F (35°C) outdoor air temperature and 80°F (27°C) db/67°F (19°C) wb entering evaporator air; minimum external duct static pressure.

² Integrated Part Load Value rated at 80°F (27°C) outdoor air temperature, 80°F (27°C) db/67°F (19°C) wb indoor air temperature.

³ Sound Rating Number rated in accordance with test conditions included in ARI Standard 270.

⁴ Maximum usable output of motors furnished by Lennox are shown. In Canada, nominal motor output is also maximum usable motor output. If motors of comparable output are used, be sure to keep within the service factor limitations outlined on the motor nameplate.

OPTIONAL FIELD INSTALLED ACCESSORIES

Item	7.5 ton 090	8.5 ton 102	10 ton 120	12.5 ton 150
Cabinet Accessories	Coil Guards	TACGKGC10/15		
	Hail Guards	TAHGKGC10/15		
	Horizontal Discharge Conversion Kit	LTHSDKGC10/15		
Ceiling Diffusers	Step-Down - Net Weight	RTD11-95 88 lbs. (40 kg)	RTD11-135 205 lbs. (93 kg)	RTD11-185 392 lbs. (178 kg)
	Flush - Net Weight	FD11-95 75 lbs. (34 kg)	FD11-135 174 lbs. (79 kg)	FD11-185 289 lbs. (131 kg)
	Transitions (Supply and Return) - Net Weight	LASRT08/10 30 lbs (14 kg)	LASRT10/12 32 lbs (15 kg)	LASRT15 36 lbs. (16 kg)
Controls	Blower Proving Switch	LTABPSK		
	Dirty Filter Switch	LTADFSK		
	L Connection® Network	See Engineering Handbook		
	Smoke Detector - Supply	LTASASDK10/36		
	Smoke Detector - Return	LTRASDK-10/30		
Cooling Accessories	PVC Condensate Drain Trap	LTACDKP03/36		
	Copper Condensate Drain Trap	LTACDKC03/36		
	High Pressure Switch	TAHPK10/15		
	Compressor Crankcase Heater	TACCHK10/15		
	Low Ambient Kit	TALAK10/15		
Economizer	Economizer - Net Weight	TAREMD10/15 - 47 lbs. (21 kg)		
	Economizer Outdoor Air Hood - Net Weight Number and Size of Filters	LAOAH10/15 - 11 lbs. (5 kg) (2) 16 x 25 x 1 in. (406 x 635 x 25 mm)		
	Economizer Enthalpy Control - Differential	LTADEK03/36		
	Economizer Enthalpy Control - Outdoor	LTASEK03/36		
Barometric Relief	Down-Flow Barometric Relief Dampers - Net Weight	LAGED10/15 - 8 lbs. (4 kg)		
	Hood for Down-Flow LAGED	LAGEH09/15		
	Horizontal Barometric Relief Dampers - Net Weight	LAGEDH03/15 - 8 lbs. (4 kg)		
Outdoor Air Dampers	Damper Section (down-flow) - Automatic - Net Weight	TAOADM10/15 - 31 lbs. (14 kg)		
	Damper Section (down-flow) - Manual - Net Weight	LAOAD10/15 - 26 lbs. (12 kg)		
	Outdoor Air Hood (down-flow) Net Weight Number and Size of Filters	LAOAH10/15 - 11 lbs. (5 kg) (2) 16 x 25 x 1 in. (406 x 635 x 25 mm)		
Power Exhaust	Power Exhaust Fan - Net Weight	LAPEF10/15 - 28 lbs. (13 kg)		
Electrical Accessories	HACR Circuit Breaker	TAHBK10/15-* (indicate size)		
	Disconnect Switch	TADK10/15-80 (80A) TADK10/15-150 (150A)		
	GFI Service Outlets	LTAGFIK10/15		
Filters	MERV 11 High Efficiency	AFK-11 (18 x 24 x 2 specify four per unit)		
Indoor Air Quality (CO₂) Sensors	CO ₂ Sensor Duct Mounting Kit	LTIAQSDMK03/36		
	Sensor - white case CO ₂ display	LTAIAQSWDK03/36		
	Sensor - white case no display	LTAIAQSWN03/36		
	Sensor - black case CO ₂ display	LTAIAQSND03/36		
	Sensor - duct mount, black, no display	LTAIAQSDMBN03/36		
	Aspiration Box for duct mounting	LTIAQABD03/36		
	Handheld CO ₂ Monitor	LTAIAQSHM03/36		
Standard Roof Curbs	14 in. (356 mm) height - Net Weight	LARMF10/15-14 - 126 lbs. (57 kg)		
	24 in. (610 mm) height - Net Weight	LARMF10/15-24 - 174 lbs. (79 kg)		
Cliplock 1000 Roof Curbs	14 in. (356 mm) height - Net Weight	LARMF10/15S-14 - 126 lbs. (57 kg)		
	18 in. (457 mm) height	LARMF10/15S-18		
	24 in. (610 mm) height - Net Weight	LARMF10/15S-24 - 174 lbs. (79 kg)		

OPTIONAL ELECTRIC HEAT ACCESSORIES

UNIT FUSE BLOCKS WITH ELECTRIC HEAT										
Unit Model No. Blower Motor Size			TCA090S	TCA090H	TCA102S	TCA102H	TCA120S	TCA120H	TCA150S	
Electric Heat			2 hp (1.5 kW)	2 hp (1.5 kW)	2 hp (1.5 kW)	2 hp (1.5 kW)	3 hp (2.2 kW)	3 hp (2.2 kW)	5 hp (3.7 kW)	
Model No.			EHA (see Electric Heat Data tables for additional information)							
kW Input Range			7.5-15-22.5-30-45				15-22.5-30-45-60			
Unit Fuse Block (3 phase)	With Power Exhaust Fans	208/230V	56K93	56K93	56K94	56K94	56K94	56K95	56K96	
		460V	56K52	56K52	25K08	25K08	25K08	25K09	25K10	
		575V	56K51	56K51	56K51	56K51	56K52	56K52	25K08	
	Without Power Exhaust Fans	208/230V	56K93	56K93	56K94	56K94	56K94	56K95	56K96	
		460V	56K52	56K52	56K52	56K52	25K08	25K09	25K09	
		575V	56K51	56K51	56K51	56K51	56K52	56K52	25K08	

LTB2 ELECTRIC HEAT TERMINAL BLOCK - LTB2-175 (30K75) 175 amps, LTB2-335 (30K76) 335 amps (Required For Units Without Disconnect/Circuit Breaker But With Single Point Power Source)											
LTB2 Terminal Block	7.5 kW	All hp	208/230V	30K75	30K75	30K75	30K75	30K75	30K75	30K75	30K75
	15 kW	All hp	208/230V	30K75	30K75	30K75	30K75	30K75	30K75	30K75	30K75
	22.5 kW	All hp	208/230V	30K75	30K75	30K75	30K75	30K75	30K75	30K75	30K75
	30 kW	All hp	208/230V	30K75	30K75	30K75	30K75	30K75	30K75	30K75	30K75
	45 kW	All hp	208/230V	30K75	30K75	30K75	30K75	30K75	30K75	30K75	30K75
	60 kW	All hp	208/230V	---	---	---	---	30K76	30K76	30K76	30K76

NOTE - All 460V and 575V models use 30K75 terminal block.

NOTE - Terminal Block is factory installed in units with factory installed electric heat without disconnect/circuit breaker but with single point power source.

ELECTRICAL DATA

7.5 TON STANDARD / HIGH EFFICIENCY													
Model No.		TCA090S						TCA090H					
Line voltage data - 60 Hz - 3 phase		208/230V		460V		575V		208/230V		460V		575V	
Compressors (2)	Rated load amps - each (total)	12.8 (25.6)		6.4 (12.8)		5.1 (10.2)		12.4 (24.9)		6.4 (12.8)		4.8 (9.6)	
	Locked rotor amps - each (total)	91 (182)		46 (92)		37 (74)		88 (176)		44 (88)		34 (68)	
Condenser Fan Motor	Number of motors	2		2		2		2		2		2	
	Full load amps - each (total)	2.4 (4.8)		1.3 (2.6)		1.0 (2.0)		2.4 (4.8)		1.3 (2.6)		1.0 (2.0)	
	Locked rotor amps - each (total)	4.7 (9.4)		2.4 (4.8)		1.9 (3.8)		4.7 (9.4)		2.4 (4.8)		1.9 (3.8)	
Evaporator Blower Motor	Motor Output - hp	2	3	2	3	2	3	2	3	2	3	2	3
	kW	1.5	2.2	1.5	2.2	1.5	2.2	1.5	2.2	1.5	2.2	1.5	2.2
	Full load amps	7.5	10.6	3.4	4.8	2.7	3.9	7.5	10.6	3.4	4.8	2.7	3.9
	Locked rotor amps	46.9	66	20.4	26.8	16.2	23.4	46.9	66	20.4	26.8	16.2	23.4
1 Maximum Overcurrent Protection (amps)	With Exhaust Fan	50	50	25	25	20	20	50	50	25	25	20	20
	Less Exhaust Fan	50	50	25	25	20	20	50	50	25	25	20	20
2 Minimum Circuit Ampacity	With Exhaust Fan	44	47	22	24	18	19	43	46	22	24	17	18
	Less Exhaust Fan	42	45	21	22	17	18	41	44	21	22	16	17
Optional Power Exhaust Fan	(Number) Horsepower (W)	(1) 1/3 (249)		(1) 1/3 (249)		(1) 1/3 (249)		(1) 1/3 (249)		(1) 1/3 (249)		(1) 1/3 (249)	
	Full load amps	2.4		1.3		1.0		2.4		1.3		1.0	
	Locked rotor amps	4.7		2.4		1.9		4.7		2.4		1.9	
Service Outlet (2) 115 volt GFCI (amp rating)		15		15		15		15		15		15	

NOTE - Extremes of operating range are plus and minus 10% of line voltage.

1 HACR type breaker or fuse.

2 Refer to National or Canadian Electrical Code manual to determine wire, fuse and disconnect size requirements.

8.5 TON STANDARD / HIGH EFFICIENCY													
Model No.		TCA102S						TCA102H					
Line voltage data - 60 Hz - 3 phase		208/230V		460V		575V		208/230V		460V		575V	
Compressors (2)	Rated load amps - each (total)	14.7 (29.4)		7.1 (14.2)		5.8 (11.6)		14.7 (29.4)		7.1 (14.2)		5.1 (10.2)	
	Locked rotor amps - each (total)	91 (182)		50 (100)		37 (74)		91 (182)		46 (92)		37 (74)	
Condenser Fan Motors (2)	Full load amps - each (total)	2.4 (4.8)		1.3 (2.6)		1.0 (2.0)		2.4 (4.8)		1.3 (2.6)		1.0 (2.0)	
	Locked rotor amps - each (total)	4.7 (9.4)		2.4 (4.8)		1.9 (3.8)		4.7 (9.4)		2.4 (4.8)		1.9 (3.8)	
Evaporator Blower Motor	Motor Output - hp	2	3	2	3	2	3	2	3	2	3	2	3
	kW	1.5	2.2	1.5	2.2	1.5	2.2	1.5	2.2	1.5	2.2	1.5	2.2
	Full load amps	7.5	10.6	3.4	4.8	2.7	3.9	7.5	10.6	3.4	4.8	2.7	3.9
	Locked rotor amps	46.9	66	20.4	26.8	16.2	23.4	46.9	66	20.4	26.8	16.2	23.4
1 Maximum Overcurrent Protection (amps)	With Exhaust Fan	60	60	30	30	20	25	60	60	30	30	20	20
	Less Exhaust Fan	60	60	25	30	20	20	60	60	25	30	20	20
2 Minimum Circuit Ampacity	With Exhaust Fan	48	51	24	25	19	20	48	51	24	25	18	19
	Less Exhaust Fan	46	49	22	27	18	19	46	49	22	24	17	18
Optional Power Exhaust Fan	(Number) Horsepower (W)	(1) 1/3 (249)		(1) 1/3 (249)		(1) 1/3 (249)		(1) 1/3 (249)		(1) 1/3 (249)		(1) 1/3 (249)	
	Full load amps	2.4		1.3		1.0		2.4		1.3		1.0	
	Locked rotor amps	4.7		2.4		1.9		4.7		2.4		1.9	
Service Outlet (2) 115 volt GFCI (amp rating)		15		15		15		15		15		15	

NOTE - Extremes of operating range are plus and minus 10 % of line voltage.

1 HACR type breaker or fuse.

2 Refer to National or Canadian Electrical Code manual to determine wire, fuse and disconnect size requirements.

ELECTRICAL DATA

10 TON STANDARD / HIGH EFFICIENCY																			
Model No.		TCA120S									TCA120H								
Line voltage data - 60 Hz - 3 phase		208/230V			460V			575V			208/230V			460V			575V		
Compressors (2)	Rated load amps - each (total)	15.4 (30.8)			7.4 (14.8)			5.9 (11.8)			17.3 (34.6)			9.0 (18.0)			7.1 (14.2)		
	Locked rotor amps - each (total)	124 (248)			59.6 (119.2)			49.4 (98.8)			123 (246)			62 (124)			50 (100)		
Condenser Fan Motors (2)	Full load amps - each (total)	2.4 (4.8)			1.3 (2.6)			1.0 (2.0)			2.4 (4.8)			1.3 (2.6)			1.0 (2.0)		
	Locked rotor amps - each (total)	4.7 (9.4)			2.4 (4.8)			1.9 (3.8)			4.9 (9.4)			2.4 (4.8)			1.9 (3.8)		
Evaporator Blower Motor	Motor Output - hp	2	3	5	2	3	5	2	3	5	2	3	5	2	3	5	2	3	5
	kW	1.5	2.2	3.7	1.5	2.2	3.7	1.5	2.2	3.7	1.5	2.2	3.7	1.5	2.2	3.7	1.5	2.2	3.7
	Full load amps	7.5	10.6	16.7	3.4	4.8	7.6	2.7	3.9	6.1	7.5	10.6	16.7	3.4	4.8	7.6	2.7	3.9	6.1
	Locked rotor amps	46.9	66	105	20.4	26.8	45.6	16.2	23.4	36.6	46.9	66	105	20.4	26.8	45.6	16.2	23.4	36.6
¹ Maximum Overcurrent Protection (amps)	With Exhaust Fan	60	60	70	30	30	35	20	25	25	70	70	80	35	35	40	25	30	30
	Less Exhaust Fan	60	60	70	30	30	30	20	25	25	60	70	70	35	35	35	25	25	30
² Minimum Circuit Ampacity	With Exhaust Fan	50	53	59	24	26	29	19	21	23	54	57	63	28	29	32	22	23	26
	Less Exhaust Fan	47	51	57	23	25	27	18	20	22	52	55	61	27	28	31	21	22	25
Optional Power Exhaust Fan	(Number) Horsepower (W)	(1) 1/3 (249)			(1) 1/3 (249)			(1) 1/3 (249)			(1) 1/3 (249)			(1) 1/3 (249)			(1) 1/3 (249)		
	Full load amps	2.4			1.3			1.0			2.4			1.3			1.0		
	Locked rotor amps	4.7			2.4			1.9			4.7			2.4			1.9		
Service Outlet (2) 115 volt GFCI (amp rating)		15			15			15			15			15			15		

NOTE - Extremes of operating range are plus and minus 10 % of line voltage.

1 HACR type breaker or fuse.

2 Refer to National or Canadian Electrical Code manual to determine wire, fuse and disconnect size requirements.

12.5 TON STANDARD EFFICIENCY									
Model No.		TCA150S							
Line voltage data - 60 Hz - 3 phase		208/230V			460V			575V	
Compressors (2)	Rated load amps - each (total)	18.6 (37.2)			9 (18)			7.4 (14.8)	
	Locked rotor amps - each (total)	156 (312)			75 (150)			54 (108)	
Condenser Fan Motors (2)	Full load amps - each (total)	3.0 (6.0)			1.5 (3.0)			1.2 (2.4)	
	Locked rotor amps - each (total)	6.0 (12.0)			3.0 (6.0)			2.9 (5.8)	
Evaporator Blower Motor	Motor Output - hp	3		5		3		5	
	kW	2.2		3.7		2.2		3.7	
	Full load amps	10.6		16.7		4.8		7.6	
	Locked rotor amps	66		105		26.8		45.6	
¹ Maximum Overcurrent Protection (amps)	With Exhaust Fan	70		80		35		40	
	Less Exhaust Fan	70		80		35		35	
² Minimum Circuit Ampacity	With Exhaust Fan	61		67		30		33	
	Less Exhaust Fan	59		65		29		31	
Optional Power Exhaust Fan	(Number) Horsepower (W)	(1) 1/3 (249)			(1) 1/3 (249)			(1) 1/3 (249)	
	Full load amps	2.4			1.3			1.0	
	Locked rotor amps	4.7			2.4			1.9	
Service Outlet (2) 115 volt GFCI (amp rating)		15			15			15	

NOTE - Extremes of operating range are plus and minus 10 % of line voltage.

1 HACR type breaker or fuse.

2 Refer to National or Canadian Electrical Code manual to determine wire, fuse and disconnect size requirements.

BLOWER DATA 090, 102, 120, 150

BELT DRIVE BLOWER - BASE UNIT

BLOWER TABLE INCLUDES RESISTANCE FOR BASE UNIT ONLY (NO HEAT SECTION) WITH DRY INDOOR COIL AND AIR FILTERS IN PLACE. FOR ALL UNITS ADD:

1 - Wet indoor coil air resistance of selected unit.

2 - Any factory installed options air resistance (heat section, economizer, etc.)

3 - Any field installed accessories air resistance (duct resistance, diffuser, etc.)

Then determine from blower table blower motor output and drive required.

BOLD INDICATES FIELD FURNISHED DRIVE.

Air Volume cfm (L/s)	Total Static Pressure - in. w.g. (Pa)																												
	.20 (50)		.40 (100)		.60 (150)		.80 (200)		1.00 (250)		1.20 (300)		1.40 (350)		1.60 (400)		1.80 (450)		2.00 (495)		2.20 (545)		2.40 (595)		2.60 (645)				
	RPM	BHP (kW)	RPM	BHP (kW)	RPM	BHP (kW)	RPM	BHP (kW)	RPM	BHP (kW)	RPM	BHP (kW)	RPM	BHP (kW)	RPM	BHP (kW)	RPM	BHP (kW)	RPM	BHP (kW)	RPM	BHP (kW)	RPM	BHP (kW)	RPM	BHP (kW)	RPM	BHP (kW)	RPM
2250 (1060)	455	0.30 (0.22)	555	0.45 (0.34)	640	0.60 (0.45)	720	0.80 (0.60)	790	1.00 (0.75)	855	1.20 (0.90)	915	1.40 (1.04)	975	1.60 (1.19)	1030	1.85 (1.38)	1080	2.05 (1.53)	1130	2.30 (1.72)	1175	2.55 (1.90)	1220	2.80 (2.09)			
2500 (1180)	475	0.40 (0.30)	575	0.55 (0.41)	660	0.70 (0.52)	735	0.90 (0.67)	805	1.10 (0.82)	870	1.30 (0.97)	930	1.55 (1.16)	985	1.75 (1.31)	1040	2.00 (1.49)	1090	2.25 (1.68)	1140	2.50 (1.87)	1185	2.75 (2.05)	1230	3.00 (2.24)			
2750 (1300)	495	0.45 (0.34)	595	0.65 (0.48)	675	0.85 (0.63)	750	1.05 (0.78)	820	1.25 (0.93)	885	1.45 (1.08)	940	1.70 (1.27)	995	1.90 (1.42)	1050	2.20 (1.64)	1100	2.45 (1.83)	1145	2.65 (1.98)	1195	2.95 (2.20)	1240	3.25 (2.42)			
3000 (1415)	525	0.55 (0.41)	615	0.75 (0.56)	695	0.95 (0.71)	770	1.20 (0.90)	835	1.40 (1.04)	895	1.60 (1.19)	955	1.85 (1.38)	1010	2.10 (1.57)	1060	2.35 (1.75)	1110	2.65 (1.98)	1160	2.90 (2.16)	1205	3.20 (2.39)	1250	3.45 (2.57)			
3250 (1535)	550	0.65 (0.48)	640	0.90 (0.67)	715	1.10 (0.82)	790	1.35 (1.01)	855	1.60 (1.19)	915	1.80 (1.34)	970	2.05 (1.53)	1025	2.35 (1.75)	1075	2.60 (1.94)	1125	2.85 (2.13)	1170	3.15 (2.35)	1215	3.40 (2.54)	1260	3.70 (2.76)			
3500 (1650)	580	0.80 (0.60)	665	1.05 (0.78)	740	1.25 (0.93)	810	1.50 (1.12)	870	1.75 (1.31)	930	2.00 (1.49)	985	2.25 (1.68)	1040	2.55 (1.90)	1090	2.85 (2.13)	1135	3.10 (2.31)	1185	3.40 (2.54)	1230	3.70 (2.76)	1270	4.00 (2.98)			
3750 (1770)	605	0.95 (0.71)	690	1.20 (0.90)	760	1.45 (1.08)	830	1.70 (1.27)	890	1.95 (1.45)	950	2.25 (1.68)	1005	2.50 (1.87)	1055	2.80 (2.09)	1105	3.10 (2.31)	1150	3.35 (2.50)	1195	3.65 (2.72)	1240	3.95 (2.95)	1285	4.30 (3.21)			
4000 (1890)	635	1.10 (0.82)	715	1.40 (1.04)	785	1.65 (1.23)	850	1.90 (1.42)	910	2.20 (1.64)	965	2.45 (1.83)	1020	2.75 (2.05)	1070	3.05 (2.28)	1120	3.35 (2.50)	1165	3.65 (2.72)	1210	3.95 (2.95)	1255	4.30 (3.21)	1295	4.60 (3.43)			
4250 (2005)	665	1.30 (0.97)	740	1.60 (1.19)	810	1.85 (1.38)	870	2.15 (1.60)	930	2.45 (1.83)	985	2.75 (2.05)	1040	3.05 (2.28)	1090	3.35 (2.50)	1135	3.65 (2.72)	1185	4.00 (2.98)	1225	4.30 (3.21)	1270	4.65 (3.47)	1310	4.95 (3.69)			
4500 (2125)	695	1.50 (1.12)	770	1.80 (1.34)	835	2.10 (1.57)	895	2.40 (1.79)	955	2.70 (2.01)	1005	3.00 (2.24)	1060	3.35 (2.50)	1105	3.65 (2.72)	1155	4.00 (2.98)	1200	4.30 (3.21)	1245	4.65 (3.47)	1285	5.00 (3.73)	1325	5.30 (3.95)			
4750 (2240)	725	1.75 (1.31)	795	2.05 (1.53)	860	2.40 (1.79)	920	2.70 (2.01)	975	3.00 (2.24)	1030	3.35 (2.50)	1080	3.65 (2.72)	1125	3.95 (2.95)	1175	4.35 (3.25)	1215	4.65 (3.47)	1260	5.00 (3.73)	1300	5.35 (3.99)	1340	5.70 (4.25)			
5000 (2360)	760	2.05 (1.53)	825	2.35 (1.75)	885	2.65 (1.98)	945	3.00 (2.24)	1000	3.35 (2.50)	1050	3.65 (2.72)	1100	4.00 (2.98)	1145	4.35 (3.25)	1190	4.70 (3.51)	1235	5.05 (3.77)	1280	5.45 (4.07)	---	---					
5250 (2475)	790	2.30 (1.72)	855	2.65 (1.98)	910	2.95 (2.20)	970	3.35 (2.50)	1020	3.65 (2.72)	1070	4.00 (2.98)	1120	4.35 (3.25)	1165	4.70 (3.51)	1210	5.10 (3.80)	1255	5.45 (4.07)	---	---	---	---					
5500 (2595)	820	2.60 (1.94)	880	2.95 (2.20)	940	3.30 (2.46)	995	3.70 (2.76)	1045	4.05 (3.02)	1095	4.40 (3.28)	1145	4.80 (3.58)	1190	5.15 (3.84)	1230	5.50 (4.10)	---	---	---	---	---	---					
5750 (2715)	850	2.95 (2.20)	910	3.30 (2.46)	965	3.70 (2.76)	1020	4.05 (3.02)	1070	4.45 (3.32)	1120	4.80 (3.58)	1165	5.20 (3.88)	1210	5.60 (4.18)	---	---	---	---	---	---	---	---					
6000 (2830)	885	3.35 (2.50)	940	3.70 (2.76)	995	4.10 (3.06)	1045	4.45 (3.32)	1095	4.85 (3.62)	1145	5.25 (3.92)	1190	5.65 (4.21)	---	---	---	---	---	---	---	---	---	---					

BLOWER DATA

DRIVE KIT SPECIFICATIONS								
Motor Outputs				RPM Range				
Nominal hp	Maximum hp	Nominal kW	Maximum kW	Drive 1	Drive 3	Drive 4	Drive 5	Drive 6
2	2.3	1.5	1.7	680 - 925	895 - 1120	---	---	---
3	3.45	2.2	2.6	680 - 925	895 - 1120	---	1110 - 1395	---
5	5.75	3.7	4.3	---	---	895 - 1120	---	1110 - 1395

NOTE - Using total air volume and system static pressure requirements determine from blower performance tables rpm and motor output required. Maximum usable output of motors furnished by Lennox are shown. In Canada, nominal motor output is also maximum usable motor output. If motors of comparable output are used, be sure to keep within the service factor limitations outlined on the motor nameplate.

CEILING DIFFUSER AIR THROW DATA						
Model No.	Air Volume		¹ Effective Throw Range			
			RTD11 Step-Down		FD11 Flush	
	cfm	L/s	ft.	m	ft.	m
090	2600	1225	24 - 29	7 - 9	19 - 24	6 - 7
	2800	1320	25 - 30	8 - 9	20 - 28	6 - 9
	3000	1415	27 - 33	8 - 10	21 - 29	6 - 9
	3200	1510	28 - 35	9 - 11	22 - 29	7 - 9
	3400	1605	30 - 37	9 - 11	22 - 30	7 - 9
102 120	3600	1700	25 - 33	8 - 10	22 - 29	7 - 9
	3800	1795	27 - 35	8 - 11	22 - 30	7 - 9
	4000	1885	29 - 37	9 - 11	24 - 33	7 - 10
	4200	1980	32 - 40	10 - 12	26 - 35	8 - 11
	4400	2075	34 - 42	10 - 13	28 - 37	9 - 11
150	5600	2645	39 - 49	12 - 15	28 - 37	9 - 11
	5800	2740	42 - 51	13 - 16	29 - 38	9 - 12
	6000	2830	44 - 54	13 - 17	40 - 50	12 - 15
	6200	2925	45 - 55	14 - 17	42 - 51	13 - 16
	6400	3020	46 - 55	14 - 17	43 - 52	13 - 16
	6600	3115	47 - 56	14 - 17	45 - 56	14 - 17

POWER EXHAUST FANS PERFORMANCE			
Return Air System Static Pressure		Air Volume Exhausted	
in. w.g.	Pa	cfm	L/s
0	0	4200	1980
0.05	12	3970	1875
0.10	25	3750	1770
0.15	37	3520	1660
0.20	50	3300	1560
0.25	62	3080	1455
0.30	75	2860	1350
0.35	87	2640	1245

¹ Throw is the horizontal or vertical distance an air stream travels on leaving the outlet or diffuser before the maximum velocity is reduced to 50 ft. (15 m) per minute. Four sides open.

BLOWER DATA

ACCESSORY AIR RESISTANCE											
Air Volume		Wet Indoor Coil				Electric Heat		Economizer		MERV 11 Filter	
		090, 102		120S, 120H, 150S		in. w.g.	Pa	in. w.g.	Pa	in. w.g.	Pa
cfm	L/s	in. w.g.	Pa	in. w.g.	Pa						
2250	1060	.06	15	.10	25	.01	2	.035	9	.01	2
2500	1180	.08	20	.12	30	.01	2	.04	10	.01	2
2750	1325	.09	22	.14	35	.01	2	.045	11	.02	5
3000	1420	.10	25	.16	40	.02	5	.05	12	.02	5
3250	1535	.11	27	.19	47	.02	5	.06	15	.02	5
3500	1650	.13	32	.21	52	.03	7	.07	17	.03	7
3750	1770	.14	35	.23	57	.03	7	.075	19	.03	7
4000	1890	.16	40	.26	65	.04	10	.08	20	.04	10
4250	2005	.17	42	.28	70	.04	10	.09	22	.04	10
4500	2125	.18	45	.31	77	.05	12	.10	25	.04	10
4750	2240	.20	50	.33	82	.05	12	.11	27	.05	12
5000	2360	.22	55	.36	90	.06	15	.12	30	.06	15
5250	2475	.24	60	.39	97	.06	15	.13	32	.06	15
5500	2595	.26	65	.42	104	.07	17	.14	35	.07	17
5750	2715	.28	70	.45	112	.07	17	.15	37	.07	17
6000	2830	.30	75	.48	119	.08	20	.16	40	.08	20

AIR RESISTANCE - CEILING DIFFUSERS										
Unit Size	Air Volume		RTD11 Step-Down Diffuser						FD11 Flush Diffuser	
			2 Ends Open		1 Side, 2 Ends Open		All Ends & Sides Open			
	cfm	L/s	in. w.g.	Pa	in. w.g.	Pa	in. w.g.	Pa	in. w.g.	Pa
090 Models	2400	1135	0.21	52	0.18	45	0.15	37	0.14	35
	2600	1225	0.24	60	0.21	52	0.18	45	0.17	42
	2800	1320	0.27	67	0.24	60	0.21	52	0.20	50
	3000	1415	0.32	80	0.29	72	0.25	62	0.25	62
	3200	1510	0.41	102	0.37	92	0.32	80	0.31	77
	3400	1605	0.50	124	0.45	112	0.39	97	0.37	92
	3600	1700	0.61	152	0.54	134	0.48	119	0.44	109
	3800	1795	0.73	182	0.63	157	0.57	142	0.51	127
102 & 120 Models	3600	1700	0.36	90	0.28	70	0.23	57	0.15	37
	3800	1795	0.40	99	0.32	80	0.26	65	0.18	45
	4000	1890	0.44	109	0.36	90	0.29	72	0.21	52
	4200	1980	0.49	122	0.40	99	0.33	82	0.24	60
	4400	2075	0.54	134	0.44	109	0.37	92	0.27	67
	4600	2170	0.60	149	0.49	122	0.42	104	0.31	77
	4800	2265	0.65	162	0.53	132	0.46	114	0.35	87
	5000	2360	0.69	172	0.58	144	0.50	124	0.39	97
5200	2455	0.75	186	0.62	154	0.54	134	0.43	107	
150 Models	4200	1980	0.22	55	0.19	47	0.16	40	0.10	25
	4400	2075	0.28	70	0.24	60	0.20	50	0.12	30
	4600	2170	0.34	85	0.29	72	0.24	60	0.15	37
	4800	2265	0.40	99	0.34	85	0.29	72	0.19	47
	5000	2360	0.46	114	0.39	97	0.34	85	0.23	57
	5200	2455	0.52	129	0.44	109	0.39	97	0.27	67
	5400	2550	0.58	144	0.49	122	0.43	107	0.31	77
	5600	2645	0.64	159	0.54	134	0.47	117	0.35	87
5800	2735	0.70	174	0.59	147	0.51	127	0.39	97	

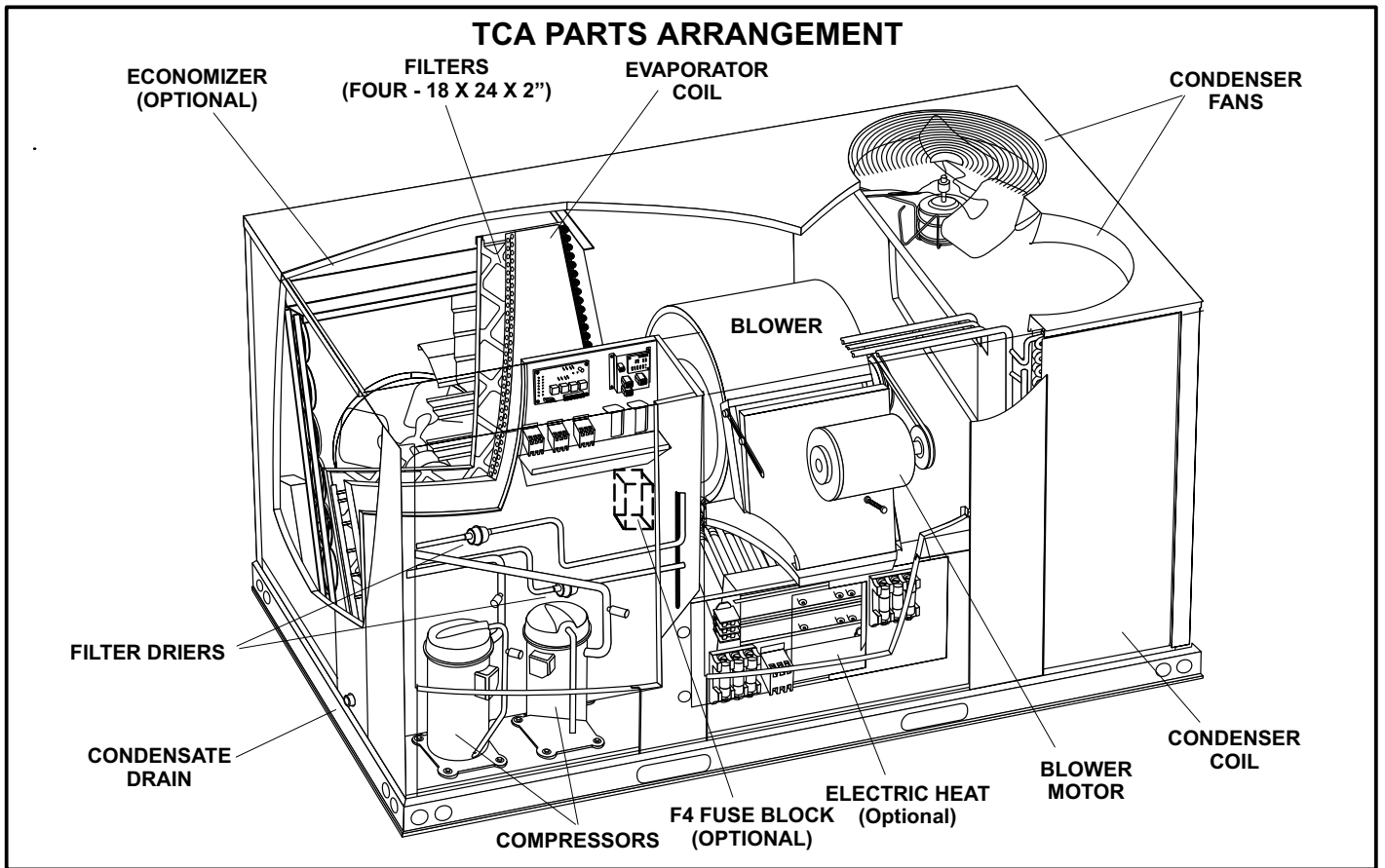

FIGURE 1

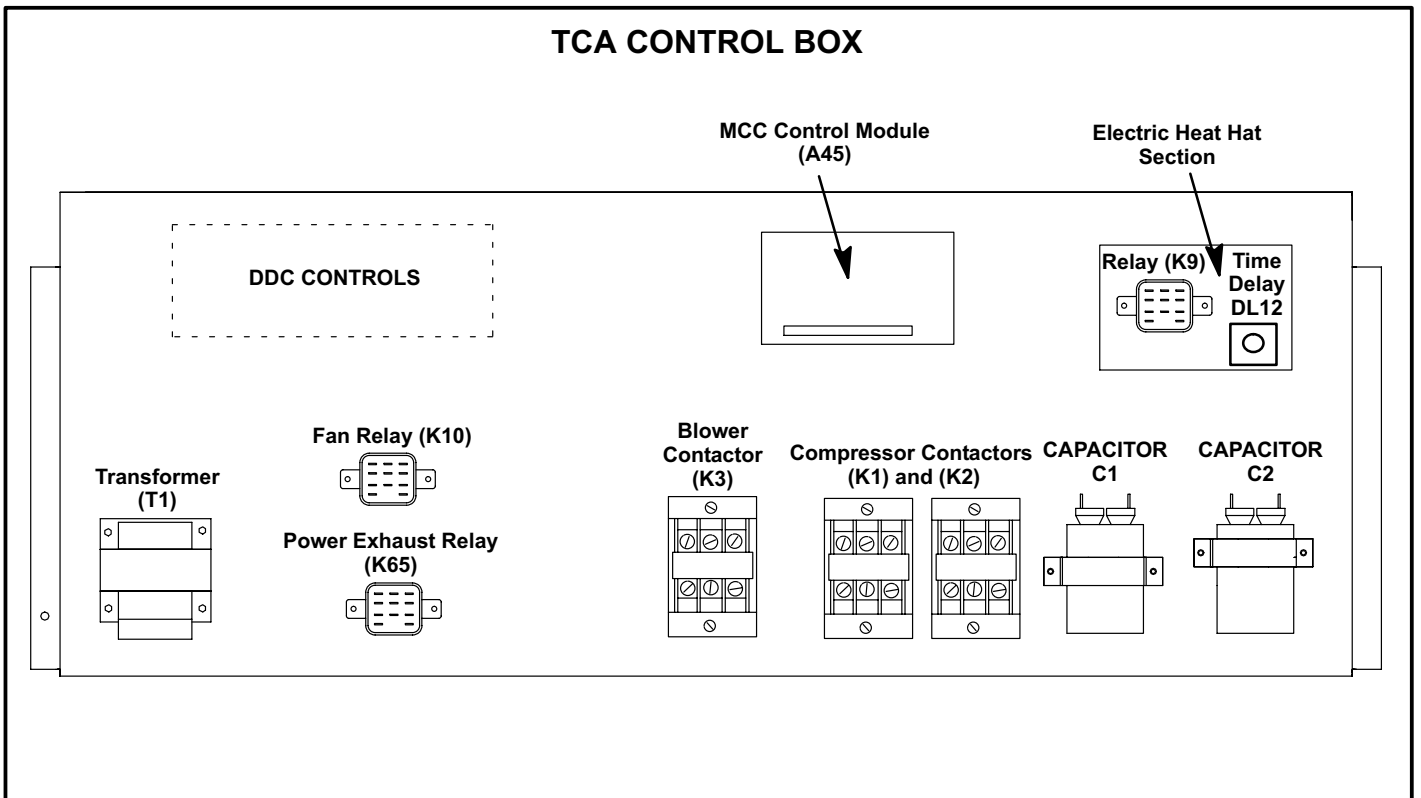



FIGURE 2

I-UNIT COMPONENTS

⚠ WARNING



Electric shock hazard. Can cause injury or death. Before attempting to perform any service or maintenance, turn the electrical power to unit OFF at disconnect switch(es). Unit may have multiple power supplies.

The TCA unit components are shown in figure 1. All units come standard with removable panels. All L1, L2, and L3 wiring is color coded; L1 is red, L2 is yellow, and L3 is blue.

A-Control Box Components

TCA control box components are shown in figure 2. The control box is located in the upper left portion of the compressor compartment.

1-Disconnect Switch S48 (Optional all units)

All units may be equipped with an optional disconnect switch S48 or circuit breaker CB10. S48 and CB10 are toggle switches, which can be used by the service technician to disconnect power to the unit.

2-Control Transformer T1 (all units)

All use a single line voltage to 24VAC transformer mounted in the control box. Transformer supplies power to control circuits in the unit. The transformer is rated at 70VA and is protected by a 3.5 amp circuit breaker (CB8). The 208/230 (Y) voltage transformers use two primary voltage taps as shown in figure 3, while 460 (G) and 575 (J) voltage transformers use a single primary voltage tap.

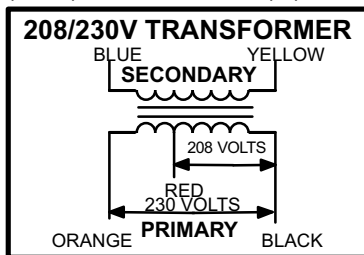

FIGURE 3

3-Terminal Strip TB1

All indoor thermostat connections will be to TB1 located on the MCC board A45. For thermostats without “occupied” and “unoccupied” modes, a factory installed jumper across terminals A1 and A2 found on the MCC board should be in place.

4-Terminal Strip TB14

Terminal strip TB14 located on the MCC board distributes 24V power from the indoor thermostat to the control box. Units not equipped with smoke detectors A17 or A64, will have a factory installed jumper across terminals 24VAC and R.

5-Condenser Fan Capacitors C1 & C2

Fan capacitors C1 and C2 are 370V / 10 MFD capacitors used to assist in the start up of condenser fans B4 and B5. Ratings are on side of capacitor or condenser fan motor nameplate.

6-Compressor Contactor K1 & K2

All compressor contactors are three-pole-double-break contactors with 24VAC coils. In all TCA090/150 units, K1 and K2 (energized by MCC board A45) energize compressors B1 and B2 in response to thermostat demand. K2 also serves as the line voltage terminal block for L1, L2 and L3.

7-Blower Contactor K3 (all units)

Blower contactor K3, used in all units, is a three-pole-double-break contactor with a 24VAC coil used to energize the indoor blower motor B3 in response to blower demand. K3 is energized by the MCC board A45.

8-Condenser Fan Relay K10

Condenser fan relay K10 is a DPDT relay with a 24VAC coil. K10 energizes condenser fans B4 and B5.

9-Power Exhaust Relay K65 (PED units)

Power exhaust relay K65 is a DPDT relay with a 24VAC coil. K65 is used in all TCA units equipped with the optional power exhaust dampers. K65 is energized by the economizer enthalpy control A6, after the economizer dampers reach 50% open (adjustable) When K65 closes, exhaust fan B10 is energized.

10-MCC Control A45

The main control module A45 (figure 5) controls all cooling operation and serves as a staging point for all internal inputs to the appropriate components of the TCA unit. The MCC control receives and sends out 24 volts to the components located in the TCA control box, economizer and supply/return compartments. The control communicates to compressors contactors K1, K2, condenser fan relay K10 and indoor blower contactor K3. Thermostat hook ups (TB1) and accessory low voltage hook ups (TB14) are located on the board. See tables 2 and 3 for terminal designations. Tables 4, 5 and 6 show pin terminal designations.

Features

The MCC A45 is equipped with a green LED for board status. See table 1 for LED flash codes. While in the cooling mode the board will incorporate AUTO-STAGING. If the board receives a Y3 demand (if applicable) the board will energize Y1, Y2 and Y3 in successive order. In the same manner a Y2, will be interpreted as a Y1/Y2. The MCC control also incorporates a minimum run time of 4 minutes for up to 2 independent cooling stages. This 4 minute run time can be interrupted by pushing SW1 located on the board. If pressed for 3 seconds or more, the control goes into TEST mode disabling AUTO-STAGING. The MCC control board is used for all T series units. A dip switch, factory set, is provided to configure to unit type (TGA gas, TCA cooling/electric heat, THA heat pump) See figure 4.

TABLE 1

LED Status	Indicates	Action
Off	No power to board.	Check field wiring. If problem persists refer to service manual.
On	Processor error.	Press MCC pushbutton and hold for three seconds to reset processor.*
Flashes Slowly	Normal.	None.
Flashes Rapidly	Invalid unit DIP switch selected.	Make sure switches are set correctly. Refer to figure 4.
Flashes Rapidly	Simultaneous heat and cool demands.	Check thermostat and wiring.

*Press pushbutton and immediately release to override the 4-minute compressor minimum run time.

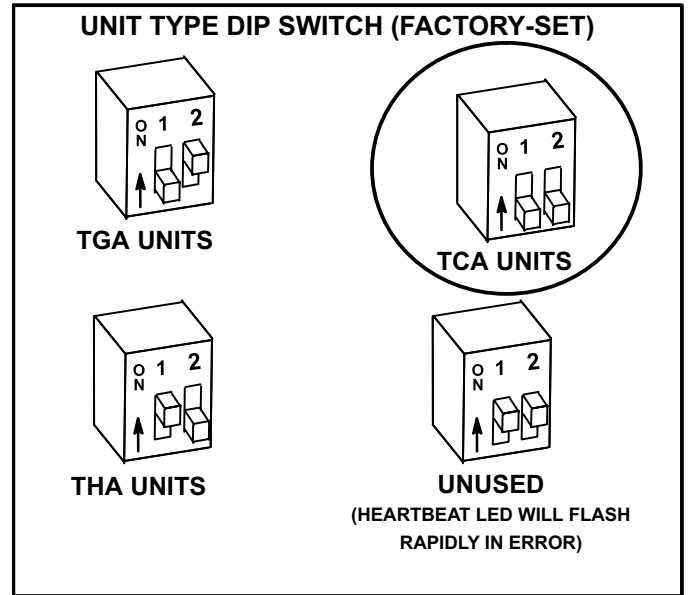

MCC CONTROL BOARD (A45)

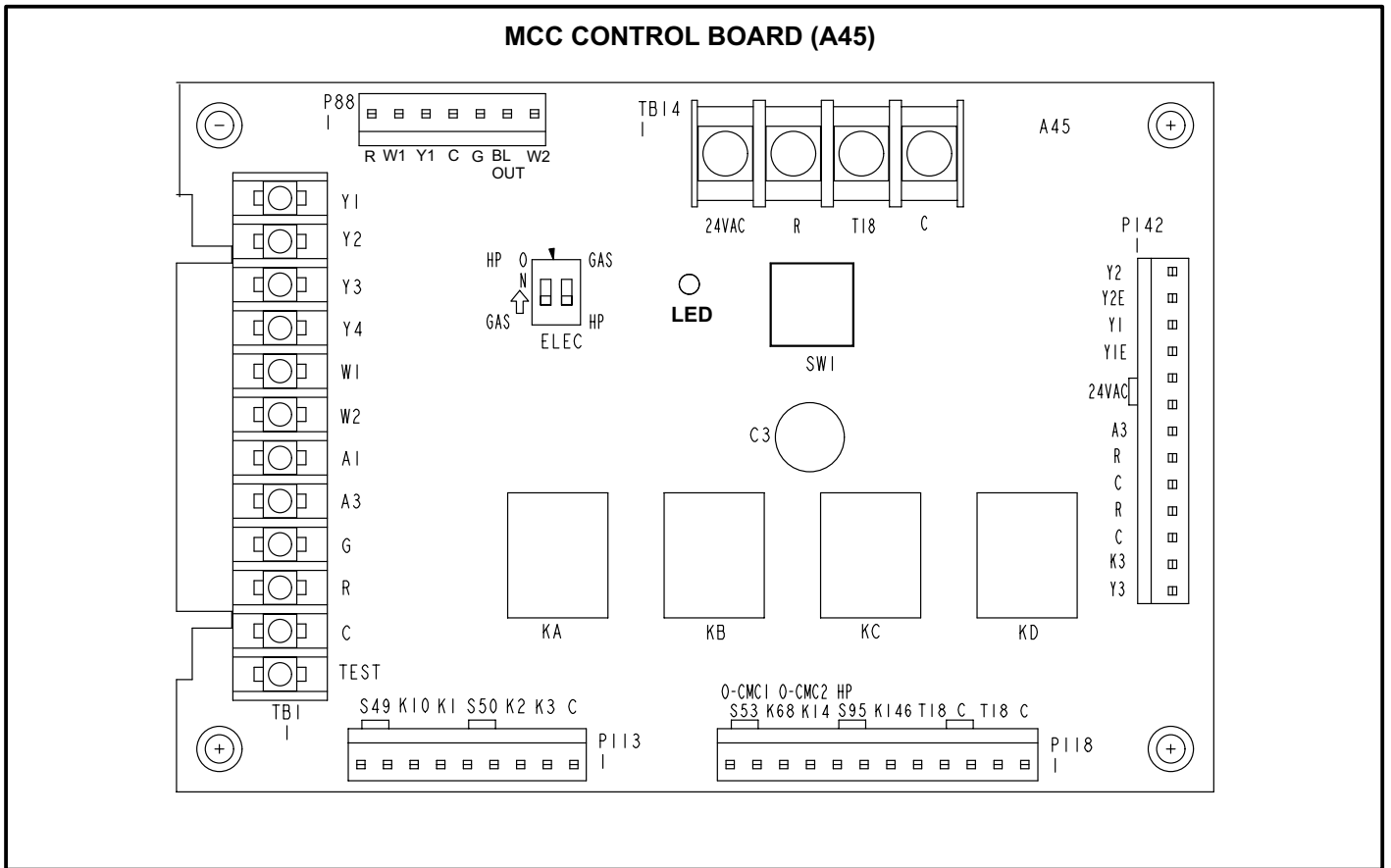

TABLE 2

TB1 TERMINAL DESIGNATIONS	
Y1	Cool Stage 1
Y2	Cool Stage 2
Y3	Cool Stage 3 (N/A)
Y4	Cool Stage 4 (N/A)
W1	Heat Stage 1
W2	Heat Stage 2
A1	Occupied Loop
A2	Occupied Loop
G	Indoor Blower
R	24V To Thermostat
C	Ground
TEST	Test Terminal (Disable Min Run Time)

TABLE 3

TB14 24VAC TERMINAL DESIGNATIONS	
24VAC	Uninterrupted 24 Volt Power
R	24 Volt Accessories (from T1 transformer)
T18	24 Volts (from T18 transformer)
C	Ground

TABLE 4

P142 TERMINAL DESIGNATIONS	
Terminal	Function
Y2	From Economizer (cool2)
Y2E	To Processor (micro chip)
Y1	From Economizer
Y1E	To Processor (micro chip)
24V	To Smoke Detector
24V	From T1 Transformer
A1	Occupied Loop from Thermostat
24V	To Economizer
GND	Ground to Economizer
24V	From Transformer T1
GND	Ground
24V	From Transformer T18
Y3	To Processor (micro chip)

TABLE 5

P113 TERMINAL DESIGNATIONS	
Terminal	Function
S49	Relay KA To Freeze Stat
S49	From Freeze Stat
K10	Relay KA To Outdoor Fan Contactor
K1	Freeze Stat to Compressor Contactor
S50	Relay KB To Freeze Stat
S50	From Freeze Stat
K2	Freeze Stat To Compressor Contactor
K3	KD To Fan Relay
C	Ground To Cooling Component

TABLE 6

P88 TERMINAL DESIGNATIONS	
Terminal	Function
R	24V To A3
W1	Heat Stage 1 to A3
Y1	Cooling Stage to A3
C	Ground to A3
G	Blower Demand to A3
BL OUT	Blower Out from A3
W2	Heat Stage 2 to A3

TCA PLUMBING, COMPRESSOR AND REFRIGERANT CIRCUITS DETAIL

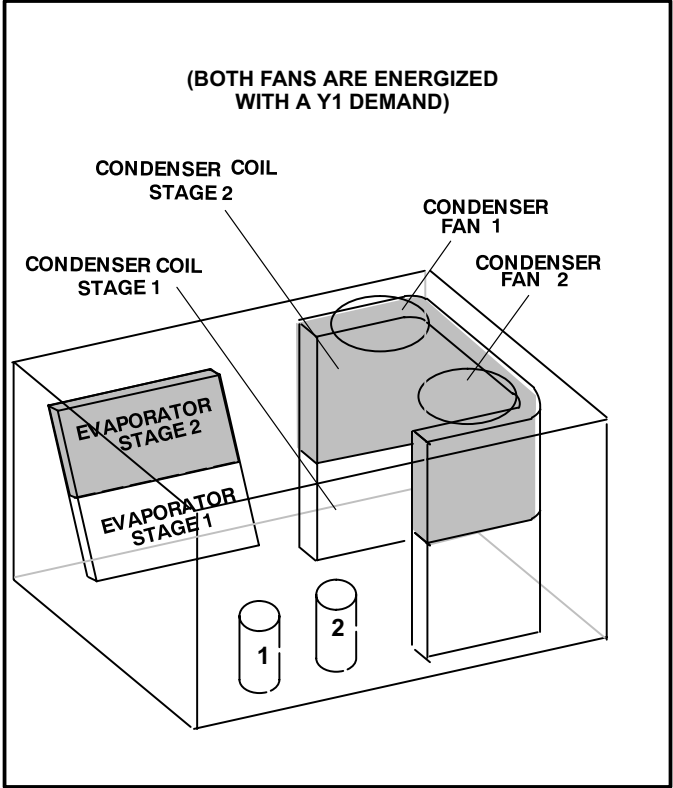
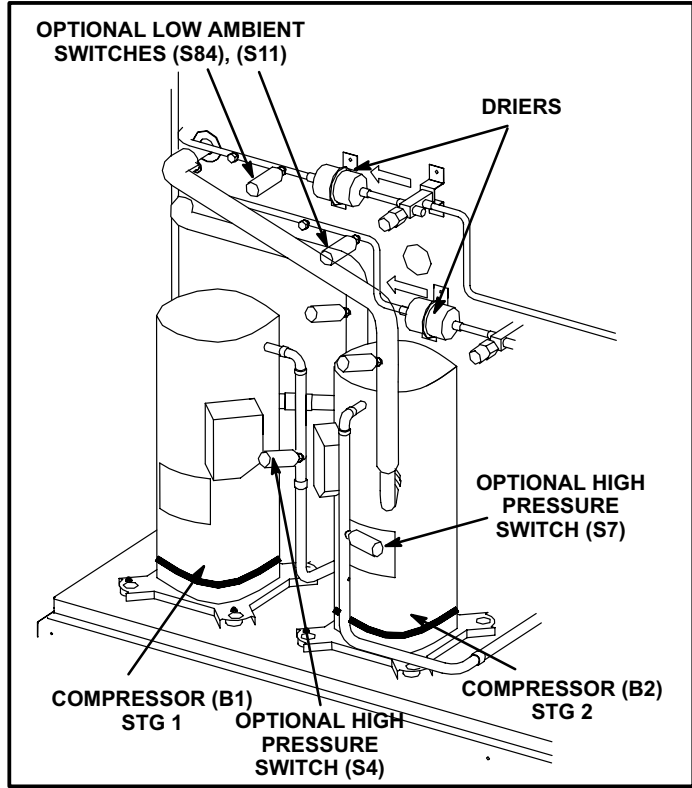
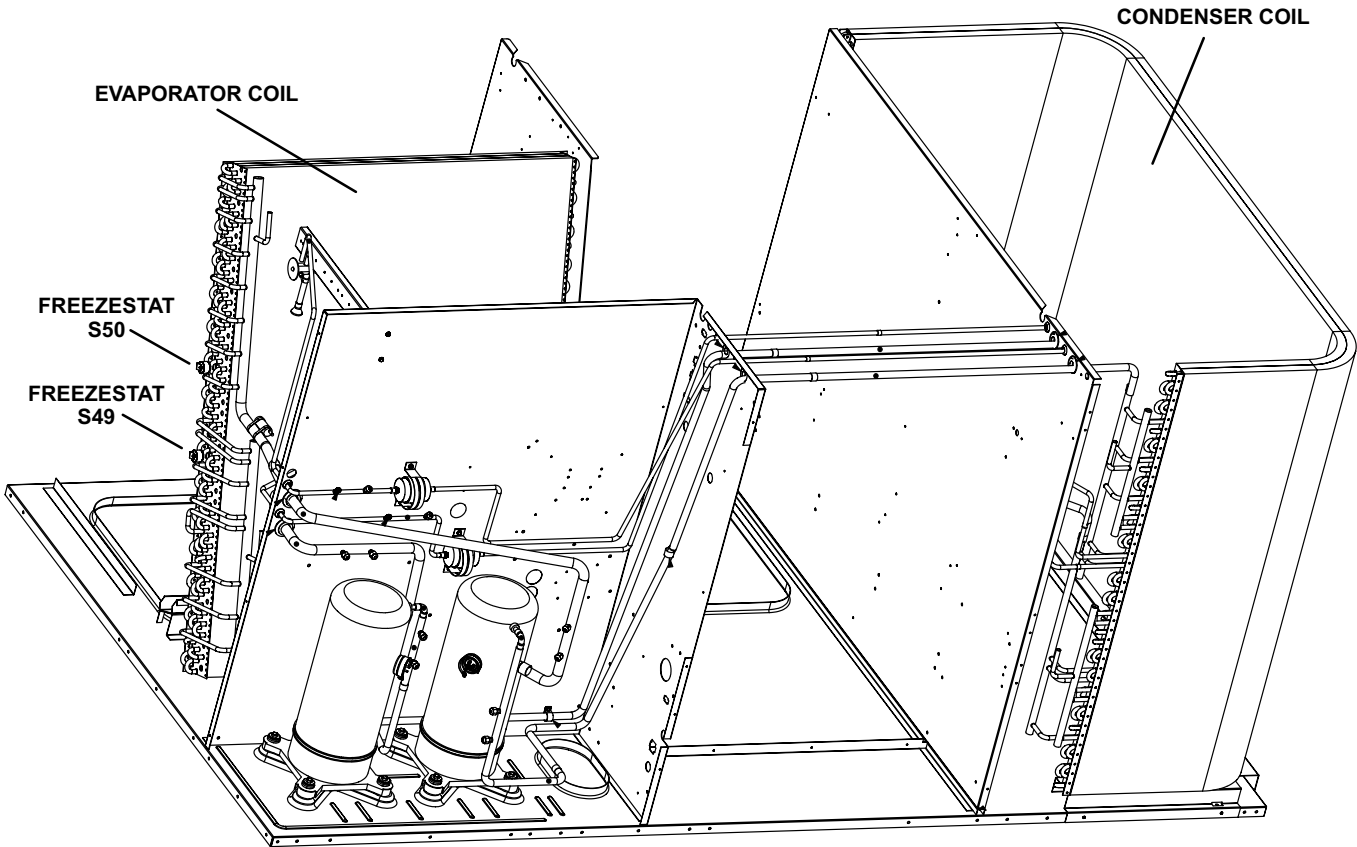

FIGURE 6

B-Cooling Components

All units use independent cooling circuits consisting of separate compressors, condenser coils and evaporator coils. See figure 6. Two draw-through type condenser fans are used in TCA090/150 units. All units are equipped with belt-drive blowers which draw air across the evaporator during unit operation.

Cooling may be supplemented by a factory- or field-installed economizer. The evaporators are slab type and are stacked. Each evaporator uses a thermostatic expansion valve as the refrigerant metering device. Each evaporator is also equipped with enhanced fins and rifled tubing. In all units each compressor is protected by a freezestat (on each evaporator). Low ambient switches (S11, S84) and high pressure switches (S4, S7) are available as an option for additional compressor protection.

1-Compressors B1 and B2

All TCA090/150 units use two scroll compressors. Compressor capacity may vary from stage to stage. In all cases, the capacity of each compressor is added to reach the total capacity of the unit. See "SPECIFICATIONS" and "ELECTRICAL DATA" (table of contents) or compressor nameplate for compressor specifications.

WARNING

Electrical shock hazard. Compressor must be grounded. Do not operate without protective cover over terminals. Disconnect power before removing protective cover. Discharge capacitors before servicing unit. Failure to follow these precautions could cause electrical shock resulting in injury or death.

Each compressor is energized by a corresponding compressor contactor.

NOTE-Refer to the wiring diagram section for specific unit operation.

2-Freezestats S49 and S50

Each unit is equipped with a low temperature switch (freezestat) located on a return bend of each evaporator coil. S49 (first circuit) and S50 (second circuit) are located on the corresponding evaporator coils.

Each freezestat is wired to the main control module A45. Each freezestat is a SPST N.C. auto-reset switch which opens at $29^{\circ}\text{F} \pm 3^{\circ}\text{F}$ ($-1.7^{\circ}\text{C} \pm 1.7^{\circ}\text{C}$) on a temperature drop and closes at $58^{\circ}\text{F} \pm 4^{\circ}\text{F}$ ($14.4^{\circ}\text{C} \pm 2.2^{\circ}\text{C}$) on a temperature rise. To prevent coil icing, freezestats open during compressor operation to temporarily disable the respective compressor until the coil temperature rises.

If the freezestats are tripping frequently due to coil icing, check the air flow / filters, economizer position and unit charge before allowing unit back in operation. Make sure to eliminate conditions which might promote evaporator ice buildup.

3-High Pressure Switches S4 and S7 (optional)

The high pressure switch is a manual-reset SPST N.C. switch which opens on a pressure rise. Each switch is located in the compressor discharge line and is wired in series with the compressor contactor coil.

When discharge pressure rises to 450 ± 10 psig (3103 ± 69 kPa) (indicating a problem in the system) the switch opens and the respective compressor is de-energized (the economizer can continue to operate).

4-Low Ambient Switches S11 & S84 (optional)

The low ambient switch is an auto-reset SPST N.O. pressure switch which allows for mechanical cooling operation at low outdoor temperatures. In all models a switch is located in each liquid line prior to the indoor coil section.

In the TCA090/150, S11 and S84 are wired in parallel with outdoor fan relay K10 (compressor one).

When liquid pressure rises to 275 ± 10 psig (1896 ± 69 kPa), the switch closes and the condenser fans are energized. When discharge pressure in both refrigerant circuits drops to 150 ± 10 psig (1034 ± 69 kPa), the switches open and the condenser fans are de-energized. This intermittent fan operation results in higher evaporating temperature allowing the system to operate without icing the evaporator coil and losing capacity.

C-Blower Compartment

The blower compartment in all TCA090/150S units is located between the evaporator coil and the condenser coil section. The blower assembly is accessed by disconnecting the blower motor. See *Blower Access* in the Operation / Adjustment section. The blower pulls out as shown in figure 8.

1-Blower Wheels

All TCA090/150 units have one 15 in. x 15 in. (381 mm x 381 mm) blower wheel.

2-Indoor Blower Motor B3

All units use three-phase single-speed blower motors. CFM adjustments are made by adjusting the motor pulley (sheave). Motors are equipped with sealed ball bearings. All motor specifications are listed in the SPECIFICATIONS (table of contents) in the front of this manual. Units may be equipped with motors manufactured by various manufacturers, therefore electrical FLA and LRA specifications will vary. See unit rating plate for information specific to your unit.

OPERATION / ADJUSTMENT

Blower Operation

Initiate blower demand at thermostat according to instructions provided with thermostat. Unit will cycle on thermostat demand. The following steps apply to applications using a typical electro-mechanical thermostat.

- 1- Blower operation is manually set at the thermostat sub-base fan switch. With fan switch in **ON** position, blowers will operate continuously.
- 2- With fan switch in **AUTO** position, the blowers will cycle with demand. Blowers and entire unit will be off when system switch is in **OFF** position.

Blower Access

The blower assembly is secured to a sliding base which allows the entire assembly to be pulled out of the unit. See figure 8.

- 1- Turn off power from unit. Remove the clamp which secures the blower wiring to the blower motor base.
- 2- Remove and retain screws on either side of sliding base. Pull base toward outside of unit.
- 3- Slide base back into original position when finished servicing. Replace the clamp and blower wiring in the previous location on the blower motor base.

Determining Unit CFM

- 1- The following measurements must be made with a dry indoor coil. Run blower without a cooling demand. Measure the indoor blower shaft RPM. Air filters must be in place when measurements are taken.
- 2- With all access panels in place, measure static pressure external to unit (from supply to return). *Measure static in duct below roof curb if roof curb is used.*
- 3- Refer to blower tables in BLOWER DATA (table of contents) in the front of this manual. Use static pressure and RPM readings to determine unit air volume.
- 4- The blower RPM can be adjusted at the motor pulley. Loosen Allen screw and turn adjustable pulley clockwise to increase CFM. Turn counterclockwise to decrease CFM. See figure 8. Do not exceed minimum and maximum number of pulley turns as shown in table 7.

**TABLE 7
MINIMUM AND MAXIMUM PULLEY ADJUSTMENT**

Belt	Minimum Turns Open	Maximum Turns Open
A Section	No minimum	5
B Section	1*	6

*No minimum number of turns open when B belt is used on pulleys 6" O.D. or larger.

Blower Belt Adjustment

Maximum life and wear can be obtained from belts only if proper pulley alignment and belt tension are maintained. Tension new belts after a 24-48 hour period of operation. This will allow belt to stretch and seat grooves. Make sure blower and motor pulley are aligned as shown in figure 7.

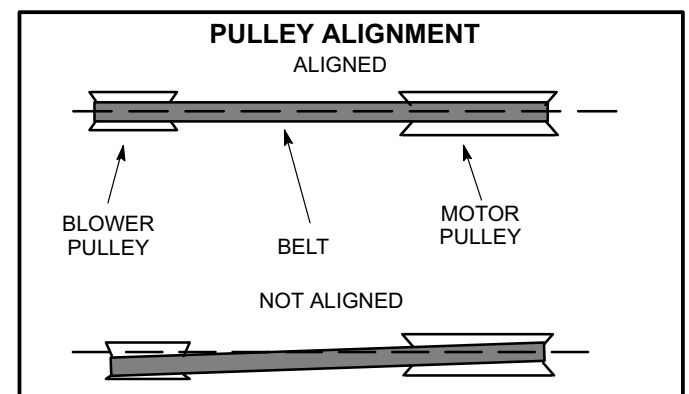

FIGURE 7

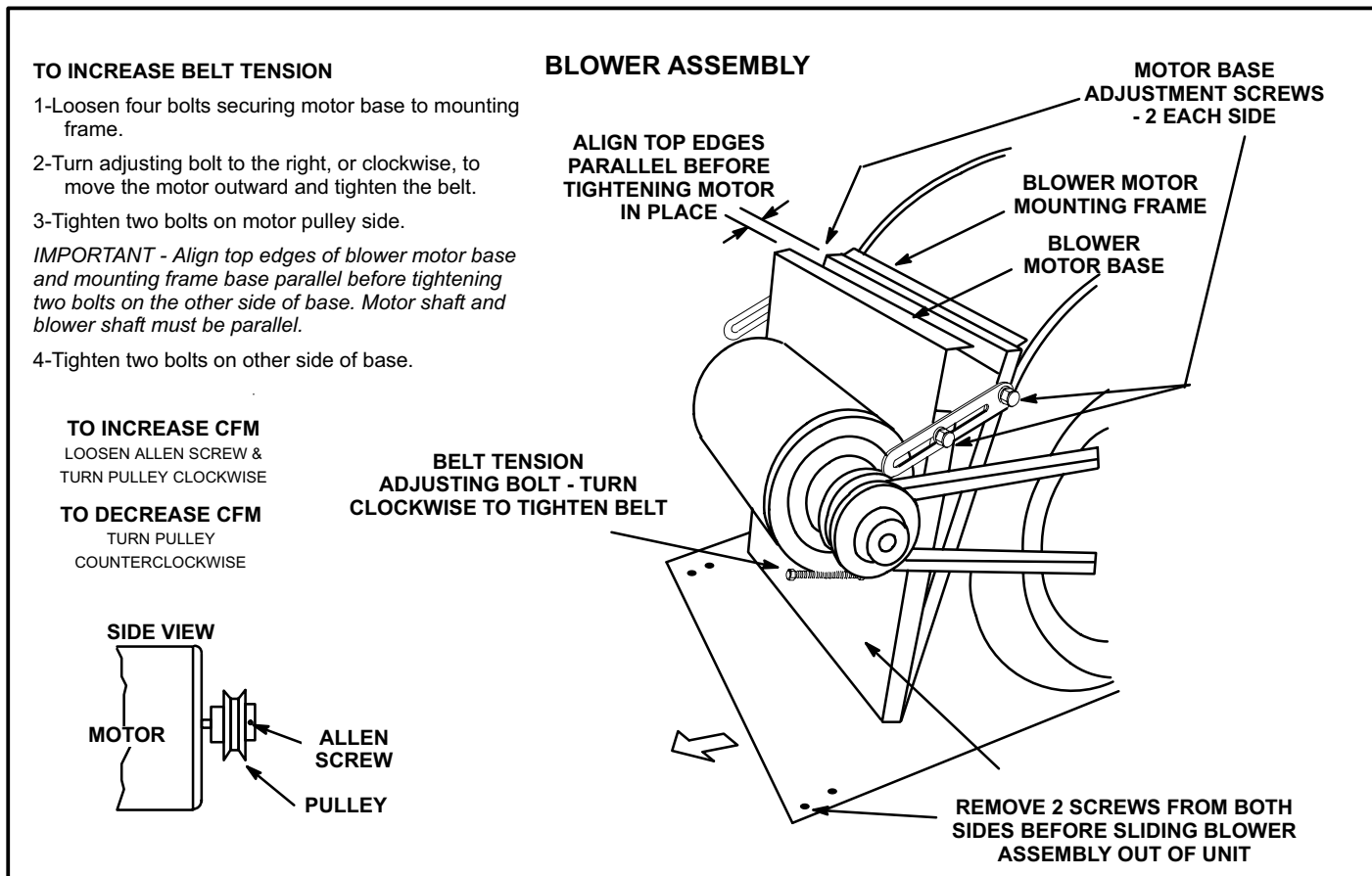

FIGURE 8

1- Loosen four bolts securing motor base to mounting frame. See figure 8.

2- *To increase belt tension -*

Turn adjusting bolt to the right, or clockwise, to move the motor outward and tighten the belt. This increases the distance between the blower motor and the blower housing.

To loosen belt tension -

Turn the adjusting bolt to the left, or counterclockwise to loosen belt tension.

3- Tighten two bolts on motor pulley side.

IMPORTANT - Align top edges of blower motor base and mounting frame base parallel before tightening two bolts on the other side of base. Motor shaft and blower shaft must be parallel.

4- Tighten two bolts on other side of base.

Check Belt Tension

Overtensioning belts shortens belt and bearing life. Check belt tension as follows:

1- Measure span length X. See figure 9.

2- Apply perpendicular force to center of span (X) with enough pressure to deflect belt 1/64" for every inch of span length or 1.5mm per 100mm of span length.

Example: Deflection distance of a 40" span would be 40/64" or 5/8".

Example: Deflection distance of a 400mm span would be 6mm.

3- Measure belt deflection force. For a used belt, the deflection force should be 5 lbs. (35kPa). A new belt deflection force should be 7 lbs. (48kPa).

A force below these values indicates an undertensioned belt. A force above these values indicates an overtensioned belt.

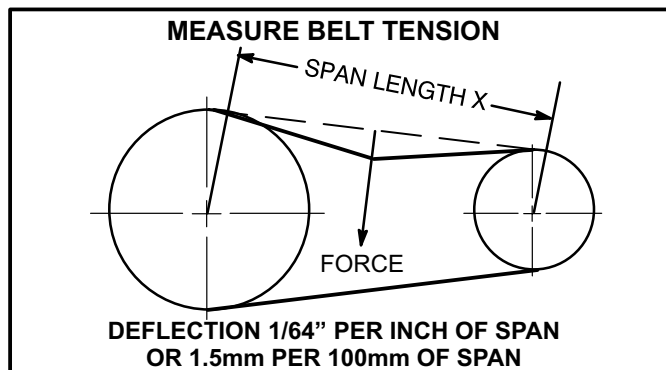

FIGURE 9

D-Optional Electric Heat Components

Tables 9 and 10 show all possible TCA to EHA matchups and electrical ratings.

All electric heat sections consist of electric heating elements exposed directly to the airstream. See figure 10. EHA parts arrangement is shown in figures 11 and 12. Multiple-stage elements are sequenced on and off in response to thermostat demand.

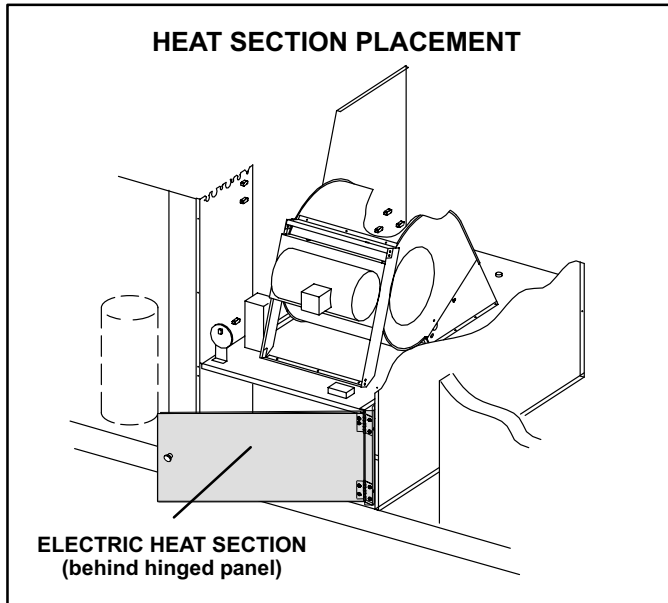

FIGURE 10

1-Electric Heat Relay K9

Electric heat relay K9 is a N.O. SPST pilot relay located on the main control panel (figure 2). K9 electrically isolates the unit's 24V circuit from the electric heat 24V circuit 9 is energized by main control A45 which in turn energizes timer DL2.

2-Time Delay DL2

DL2 is a factory installed solid state timer used in 22.5 to 60 kW electric heat units. DL2 is located on the main control panel (figure 2). DL2 allows staging by providing a timed-interval between the first and second heating elements. When the timer is energized, the contacts are delayed for 30 seconds before closing. When the timer is de-energized, the contacts are delayed 1 second before opening.

3-Contactors K15, K16

Contactors K15 and K16 are three-pole double-break contactors located on the electric heat vestibule. All contactors are equipped with a 24VAC coil. The coils in the K15 and K16 contactors are energized by the main panel A45. Contactor K15 energizes the first stage heating elements, while K16 energizes the second stage heating elements.

4-High Temperature Limits S15 (Primary)

S15 is a SPST N.C. auto-reset thermostat located on the back panel of the electric heat section below the heating elements. S15 is the high temperature limit for the electric heat section. When S15 opens, indicating a problem in

the system, contactor K15 is de-energized. When K15 is de-energized, first stage and all subsequent stages of heat are de-energized. For EHA102/150 units, the high temperature limit is factory set to open at $170^{\circ}\text{F} \pm 5^{\circ}\text{F}$ ($76^{\circ}\text{C} \pm 2.8^{\circ}\text{C}$) on a temperature rise and automatically reset at $130^{\circ}\text{F} \pm 6^{\circ}\text{F}$ ($54.4^{\circ}\text{C} \pm 3.3^{\circ}\text{C}$) on a temperature fall. For EHA100 units, the limit is factory set to open at $160^{\circ}\text{F} \pm 5^{\circ}\text{F}$ ($71.0^{\circ}\text{C} \pm 2.8^{\circ}\text{C}$) on a temperature rise and automatically reset at $120^{\circ}\text{F} \pm 6^{\circ}\text{F}$ ($49.0^{\circ}\text{C} \pm 3.3^{\circ}\text{C}$) on a temperature fall. The limit is not adjustable.

5-High Temperature Limit S20 (Secondary)

S20 is a SPST N.C. manual-reset thermostat. Like the primary temperature limit, S20 is wired in series with the first stage contactor coil (K15) and second stage contactor coil (K16). When S20 opens, contactors (K15, K16) are de-energized. When the contactors are de-energized, first stage and all subsequent stages of heat are de-energized. The limit is factory set to open at $220^{\circ}\text{F} \pm 6^{\circ}\text{F}$ ($104^{\circ}\text{C} \pm 3.3^{\circ}\text{C}$) on a temperature rise and can be manually reset when temperature falls below 160°F (71.0°C).

6-Terminal Strip TB3

Electric heat line voltage connections are made to terminal strip TB3 (or a fuse block on some models) located in the upper left corner of the electric heat vestibule.

7-Heating Elements HE1, HE2, HE6 and HE7

Heating elements are composed of helix wound bare nichrome wire exposed directly to the airstream. Three elements are connected in a three-phase arrangement. The elements in 208/230V units are connected in a "Delta" arrangement. Elements in 460 and 575V units are connected in "Wye" arrangement. Each stage is energized independently by the corresponding contactors located on the electric heat vestibule panel. Once energized, heat transfer is instantaneous. High temperature protection is provided by primary and redundant high temperature limits and overcurrent protection is provided by fuses.

8-Fuse F3

Fuse F3 are housed in a fuse block which holds three fuses. Each F3 fuse is connected in series with each leg of electric heat. Figure 11 and table 8 show the fuses used with each electric heat section. For simplicity, the service manual labels the fuses F3 - 1 through F3 - 4.

9-Fuse F4

Fuse F4 is used only with single point power along with TB2. F4 gives over amperage protection to the compressor and other cooling components while F3 protects the electrical heat component. The F 4 fuse block is located inside a sheetmetal enclosure (figure 1).

TABLE 8

TCA ELECTRIC HEAT SECTION FUSE RATING					
EHA QUANTITY & SIZE	VOLTAGES	FUSE (3 each)			
		F3 - 1	F3 - 2	F3 - 3	F3 - 4
EHA100-7.5	208/230V	25 Amp 250V	----	----	----
	460V	15 Amp 600V	----	----	----
	575V	10 Amp 600V	----	----	----
EHA100-15	208/230V	50 Amp 250V	----	----	----
	460V	25 Amp 600V	----	----	----
	575V	20 Amp 600V	----	----	----
EHA100-22.5	208/230V	50 Amp 250V	----	----	25 Amp 250V
	460V	25 Amp 600V	----	----	15 Amp 600V
	575V	20 Amp 600V	----	----	10 Amp 600V
EHA100-30	208/230V	50 Amp 250V	----	----	50 Amp 250V
	460V	25 Amp 600V	----	----	25 Amp 600V
	575V	20 Amp 600V	----	----	20 Amp 600V
EHA100-45	208/230V	50 Amp 250V	----	60 Amp 250V	60 Amp 250V
	460V	25 Amp 600V	----	----	50 Amp 600V
	575V	20 Amp 600V	----	----	40 Amp 600V
EHA102-7.5	208/230V	25 Amp 250V	----	----	----
	460V	15 Amp 600V	----	----	----
	575V	10 Amp 600V	----	----	----
EHA150-15	208/230V	50 Amp 250V	----	----	----
	460V	25 Amp 600V	----	----	----
	575V	20 Amp 600V	----	----	----
EHA360-22.5	208/230V	50 Amp 250V	----	----	25 Amp 250V
	460V	25 Amp 600V	----	----	15 Amp 600V
	575V	20 Amp 600V	----	----	10 Amp 600V
EHA150-30	208/230V	50 Amp 250V	----	----	50 Amp 250V
	460V	25 Amp 600V	----	----	25 Amp 600V
	575V	20 Amp 600V	----	----	20 Amp 600V
EHA150-45	208/230V	50 Amp 250V	----	60 Amp 250V	60 Amp 250V
	460V	25 Amp 600V	----	----	50 Amp 600V
	575V	20 Amp 600V	----	----	40 Amp 600V
EHA150-60	208/230V	60 Amp 250V	60 Amp 250V	60 Amp 250V	60 Amp 250V
	460V	50 Amp 600V	----	----	50 Amp 600V
	575V	40 Amp 600V	----	----	40 Amp 600V

**EHA 7.5, 15, 22.5, 30, 45, 60KW
ELECTRIC HEAT SECTION PARTS ARRANGEMENT**

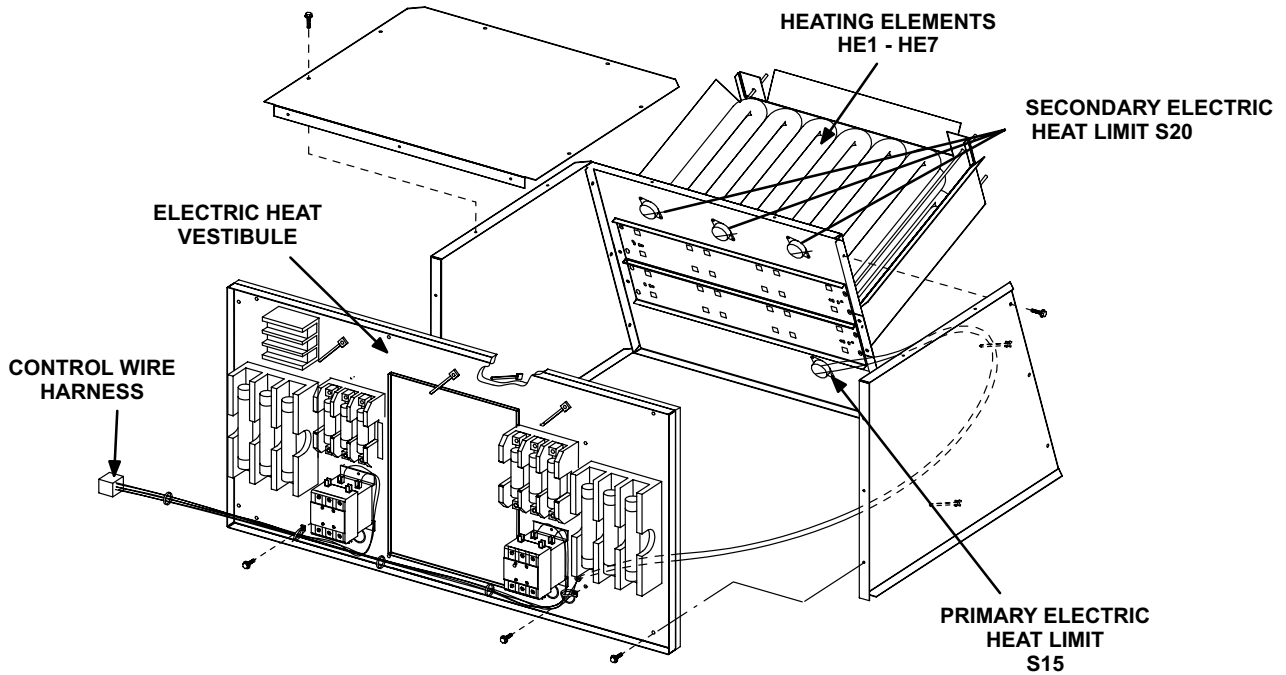

FIGURE 11

ELECTRIC HEAT VESTIBULE PARTS ARRANGEMENT

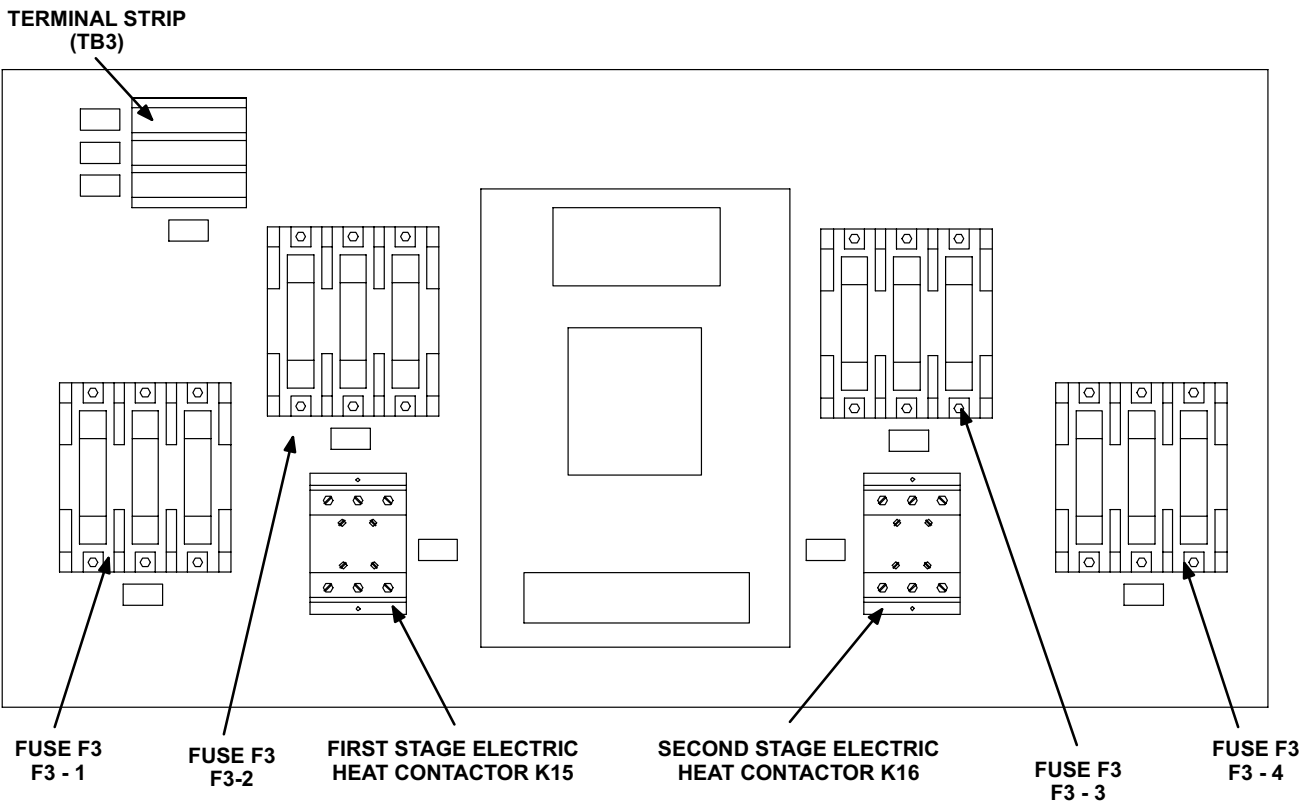

FIGURE 12

TABLE 9

7.5 TON STANDARD / HIGH EFFICIENCY - TCA090

8.5 TON STANDARD / HIGH EFFICIENCY - TCA102

REQUIRES UNIT FUSE BLOCK, TERMINAL BLOCK AND ¹ HEATER CONTROL MODULE

¹ Electric Heat Model No. & Net Weight	No. of Steps	Volts Input	kW Input	Btuh Output	² Minimum Circuit Ampacity Total Unit + Electric Heat (with Power Exhaust Fan)		³ Maximum Overcurrent Protection Total Unit + Electric Heat (with Power Exhaust Fans)	
					TCA090	TCA102	TCA090	TCA102
7.5 kW EHA102-7.5 208/230V 99J01 460V 99J02 575V 99J03 31 lbs. (14 kg)	1	208	5.6	19,100	090H - 43 090S - 44	48	50	60
	1	220	6.3	21,500				
	1	230	6.9	23,600				
	1	240	7.5	25,600				
	1	440	6.3	21,500	22	24	25	30
	1	460	6.9	23,600				
	1	480	7.5	25,600				
	1	550	6.3	21,500	090H - 17 090S - 18	102H - 18 102S - 19	20	20
1	575	6.9	23,600					
1	600	7.5	25,600					
15 kW EHA150-15 208/230V 99J04 460V 99J05 575V 99J06 31 lbs. (14 kg)	1	208	11.3	38,600	58	58	60	60
	1	220	12.6	43,000				
	1	230	13.8	47,100				
	1	240	15.0	51,200				
	1	440	12.6	43,000	29	29	30	30
	1	460	13.8	47,100				
	1	480	15.0	51,200				
	1	550	12.6	43,000	23	23	25	25
1	575	13.8	47,100					
1	600	15.0	51,200					
22.5 kW EHA360-22.5 208/230V 99J28 460V 99J29 575V 99J30 38 lbs. (17 kg)	² 2	208	16.9	57,700	80	80	80	80
	² 2	220	18.9	64,500				
	² 2	230	20.6	70,700				
	² 2	240	22.5	76,800				
	² 2	440	18.9	64,500	40	40	40	40
	² 2	460	20.7	70,700				
	² 2	480	22.5	76,800				
	² 2	550	19.0	64,500	32	32	35	35
² 2	575	20.7	70,700					
² 2	600	22.5	76,800					
30 kW EHA150-30 208/230V 99J07 460V 99J08 575V 99J09 38 lbs. (17 kg)	² 2	208	22.5	76,800	103	103	110	110
	² 2	220	25.2	86,000				
	² 2	230	27.6	93,900				
	² 2	240	30.0	102,400				
	² 2	440	25.2	86,000	51	51	60	60
	² 2	460	27.6	93,900				
	² 2	480	30.0	102,400				
	² 2	550	25.2	86,000	41	41	45	45
² 2	575	27.6	93,900					
² 2	600	30.0	102,400					
45 kW EHA150-45 208/230V 99J10 460V 99J11 575V 99J12 42 lbs. (19 kg)	² 2	208	33.8	115,300	148	148	150	150
	² 2	220	37.8	129,000				
	² 2	230	41.3	141,000				
	² 2	240	45.0	153,600				
	² 2	440	37.8	129,000	74	74	80	80
	² 2	460	41.3	141,000				
	² 2	480	45.0	153,600				
	² 2	550	37.8	129,000	59	59	60	60
² 2	575	41.3	141,000					
² 2	600	45.0	153,600					

¹ Fuse block must be ordered extra. Factory installed heaters will have the fuse block factory installed. Fuse block must be installed in field installed heaters. Also requires LTB2 Terminal Block. See Optional Electric Heat Accessories tables.

² Refer to National or Canadian Electrical Code manual to determine wire, fuse and disconnect size requirements. Use wires suitable for at least 167°F (75°C).

³ HACR type breaker or fuse.

⁴ Can be used with two stage control.

TABLE 10

10 TON STANDARD / HIGH EFFICIENCY - TCA120

12.5 TON STANDARD EFFICIENCY - TCA150

REQUIRES UNIT FUSE BLOCK, TERMINAL BLOCK AND ¹ HEATER CONTROL MODULE

¹ Electric Heat Model No. & Net Weight	No. of Steps	Volts Input	kW Input	Btuh Output	² Minimum Circuit Ampacity Total Unit + Electric Heat (with Power Exhaust Fan)		³ Maximum Overcurrent Protection Total Unit + Electric Heat (with Power Exhaust Fans)		
					TCA120	TCA150	TCA120	TCA150	
15 kW EHA150-15 208/230V 99J04 460V 99J05 575V 99J06 31 lbs. (14 kg)	1	208	11.3	38,600	62	69	120H - 70 120S - 60	80	
	1	220	12.6	43,000					
	1	230	13.8	47,100					
	1	240	15.0	51,200					
	1	440	12.6	43,000	31	34	120H - 35 120S - 30	40	
	1	460	13.8	47,100					
	1	480	15.0	51,200					
	1	550	12.6	43,000					
1	575	13.8	47,100	25	27	25	30		
1	600	15.0	51,200						
22.5 kW EHA360-22.5 208/230V 99J28 460V 99J29 575V 99J30 38 lbs. (17 kg)	² 2	208	16.9	57,700	84	92	90	100	
	² 2	220	18.9	64,500					
	² 2	230	20.7	70,700					
	² 2	240	22.5	76,800					
	² 2	440	18.9	64,500	42	45	45	45	
	² 2	460	20.7	70,700					
	² 2	480	22.5	76,800					
	² 2	550	18.9	64,500					
	² 2	575	20.7	70,700	34	36	35	40	
	² 2	600	22.5	76,800					
	30 kW EHA150-30 208/230V 99J07 460V 99J08 575V 99J09 38 lbs. (17 kg)	² 2	208	22.5	76,800	107	115	110	125
		² 2	220	25.2	86,000				
² 2		230	27.5	93,900					
² 2		240	30.0	102,400					
² 2		440	25.2	86,000	53	57	60	60	
² 2		460	27.5	93,900					
² 2		480	30.0	102,400					
² 2		550	25.2	86,000					
² 2		575	27.5	93,900	43	45	45	45	
² 2		600	30.0	102,400					
45 kW EHA150-45 208/230V 99J10 460V 99J11 575V 99J12 42 lbs. (19 kg)		² 2	208	33.8	115,300	152	160	175	175
		² 2	220	37.8	129,000				
	² 2	230	41.3	141,000					
	² 2	240	45.0	153,600					
	² 2	440	37.8	129,000	76	79	80	80	
	² 2	460	41.3	141,000					
	² 2	480	45.0	153,600					
	² 2	550	37.8	129,000					
	² 2	575	41.3	141,000	61	63	70	70	
	² 2	600	45.0	153,600					
	60 kW EHA150-60 208/230V 99J13 460V 99J14 575V 99J15 49 lbs. (22 kg)	² 2	208	45.0	153,600	161	169	175	175
		² 2	220	50.4	172,000				
² 2		230	55.1	188,000					
² 2		240	60.0	204,800					
² 2		440	50.4	172,000	80	84	80	90	
² 2		460	55.1	188,000					
² 2		480	60.0	204,800					
² 2		550	50.4	172,000					
² 2		575	55.1	188,000	64	67	70	70	
² 2		600	60.0	204,800					

¹ Fuse block must be ordered extra. Factory installed heaters will have the fuse block factory installed. Fuse block must be installed in field installed heaters. Also requires LTB2 Terminal Block. See Optional Electric Heat Accessories tables.

² Refer to National or Canadian Electrical Code manual to determine wire, fuse and disconnect size requirements. Use wires suitable for at least 167°F (75°C).

³ HACR type breaker or fuse.

⁴ Can be used with two stage control.

II-PLACEMENT AND INSTALLATION

Make sure the unit is installed in accordance with the installation instructions and all applicable codes. See accessories section for conditions requiring use of the optional roof mounting frame (LARMF18/36 or LARMFH18/24).

III-Start Up - Operation

A-Preliminary and Seasonal Checks

- 1- Make sure the unit is installed in accordance with the installation instructions and applicable codes.
- 2- Inspect all electrical wiring, both field and factory installed for loose connections. Tighten as required. Refer to unit diagram located on inside of compressor access panel.
- 3- Check to ensure that refrigerant lines are in good condition and do not rub against the cabinet or other refrigerant lines.
- 4- Check voltage at the disconnect switch. Voltage must be within the range listed on the nameplate. If not, consult the power company and have the voltage corrected before starting the unit.
- 5- Recheck voltage and amp draw with unit running. If voltage is not within range listed on unit nameplate, stop unit and consult power company. Refer to unit nameplate for maximum rated load amps.
- 6- Inspect and adjust blower belt (see section on Blower Compartment - Blower Belt Adjustment).

B-Operation

- 1- Initiate first and second stage cooling demands according to instructions provided with thermostat.
- 2- First-stage thermostat demand will energize compressor 1. Second-stage thermostat demand will energize compressor 2. On units with an economizer, when outdoor air is acceptable, a first-stage demand will energize the economizer; a second-stage demand will energize compressor 1.
- 3- Units contain two refrigerant circuits or stages. See figure 13.

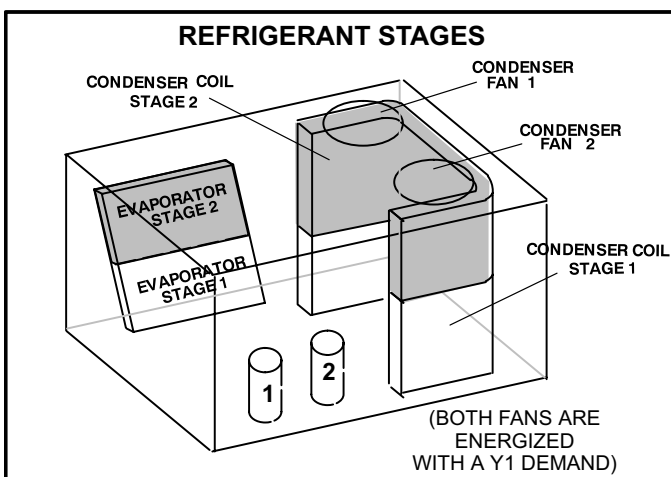

FIGURE 13

- 4- Each refrigerant circuit is separately charged with HCFC-22 refrigerant. See unit rating plate for correct amount of charge.
- 5- Refer to IV-Charging for proper method to check refrigerant charge.

Three Phase Scroll Compressor Voltage Phasing

Three phase power supplied to the unit disconnect switch must be phased sequentially to ensure the scroll compressor and indoor blower rotate in the correct direction. Compressor and blower are wired in phase at the factory. Power wires are color-coded as follows: line 1-red, line 2-yellow, line 3-blue.

- 1- Observe suction and discharge pressures and blower rotation on unit start-up.
- 2- Suction pressure must drop, discharge pressure must rise, and blower rotation must match rotation marking.

If pressure differential is not observed or blower rotation is not correct:

- 3- Disconnect all remote electrical power supplies.
- 4- Reverse any two field-installed wires connected to the line side of K2 contactor. Do not reverse wires at blower contactor.
- 5- Make sure the connections are tight.

Discharge and suction pressures should operate at their normal start-up ranges.

IV-Charging

WARNING-Do not exceed nameplate charge under any condition.

This unit is factory charged and should require no further adjustment. If the system requires charge, reclaim the charge, evacuate the system, and add required nameplate charge.

*NOTE - System charging is not recommended below 60°F (15°C). In temperatures below 60°F (15°C), the charge **must** be weighed into the system.*

If weighing facilities are not available, or to check the charge, use the following procedure:

- 1- Attach gauge manifolds and operate unit in cooling mode until system stabilizes (approximately five minutes). Make sure outdoor air dampers are closed.
- 2- Check each system separately with all stages operating.
- 3- Use a thermometer to accurately measure the outdoor ambient temperature.
- 4- Apply the outdoor temperature to tables 11 through 17 to determine normal operating pressures.
- 5- Compare the normal operating pressures to the pressures obtained from the gauges. Minor variations in these pressures may be expected due to differences in installations. Significant differences could mean that the system is not properly charged or that a problem exists with some component in the system. **Correct any system problems before proceeding.**

6- If discharge pressure is high, remove refrigerant from the system. If discharge pressure is low, add refrigerant to the system.

- Add or remove charge in increments.
- Allow the system to stabilize each time refrigerant is added or removed.

7- Use the following approach method along with the normal operating pressures to confirm readings.

**TABLE 11
TCA090S NORMAL OPERATING PRESSURES**

Outdoor Coil Entering Air Temp	CIRCUIT 1		CIRCUIT 2	
	Dis. ±10 psig	Suct. ±5 psig	Dis. ±10 psig	Suc. ±5 psig
65°F	175	74	180	73
75°F	200	76	206	73
85°F	228	77	236	74
95°F	260	79	269	75
105°F	292	80	303	77
115°F	329	82	343	80

**TABLE 12
TCA090H NORMAL OPERATING PRESSURES**

Outdoor Coil Entering Air Temp	CIRCUIT 1		CIRCUIT 2	
	Dis. ±10 psig	Suct. ±5 psig	Dis. ±10 psig	Suc. ±5 psig
65°F	152	74	156	76
75°F	175	77	181	78
85°F	202	79	209	80
95°F	231	81	239	81
105°F	262	81	274	83
115°F	295	82	310	85

**TABLE 13
TCA102S NORMAL OPERATING PRESSURES**

Outdoor Coil Entering Air Temp	CIRCUIT 1		CIRCUIT 2	
	Dis. ±10 psig	Suct. ±5 psig	Dis. ±10 psig	Suc. ±5 psig
65°F	170	74	178	73
75°F	196	75	204	73
85°F	227	77	237	74
95°F	260	79	272	76
105°F	298	81	313	77
115°F	341	83	360	79

**TABLE 14
TCA102H NORMAL OPERATING PRESSURES**

Outdoor Coil Entering Air Temp	CIRCUIT 1		CIRCUIT 2	
	Dis. ±10 psig	Suct. ±5 psig	Dis. ±10 psig	Suc. ±5 psig
65°F	156	72	160	75
75°F	181	75	186	77
85°F	207	76	213	79
95°F	234	77	243	81
105°F	266	78	277	82
115°F	300	80	313	84

**TABLE 15
TCA120S NORMAL OPERATING PRESSURES**

Outdoor Coil Entering Air Temp	CIRCUIT 1		CIRCUIT 2	
	Dis. ±10 psig	Suct. ±5 psig	Dis. ±10 psig	Suc. ±5 psig
65°F	169	74	176	77
75°F	195	77	203	79
85°F	222	79	233	81
95°F	252	81	264	82
105°F	283	82	300	83
115°F	319	84	340	84

**TABLE 16
TCA120H NORMAL OPERATING PRESSURES**

Outdoor Coil Entering Air Temp	CIRCUIT 1		CIRCUIT 2	
	Dis. ±10 psig	Suct. ±5 psig	Dis. ±10 psig	Suc. ±5 psig
65°F	163	72	168	76
75°F	188	76	193	78
85°F	214	78	221	80
95°F	244	80	252	81
105°F	275	81	286	83
115°F	309	83	322	84

**TABLE 17
TCA150S NORMAL OPERATING PRESSURES**

Outdoor Coil Entering Air Temp	CIRCUIT 1		CIRCUIT 2	
	Dis. ±10 psig	Suct. ±5 psig	Dis. ±10 psig	Suc. ±5 psig
65°F	179	67	176	70
75°F	205	70	200	72
85°F	231	72	227	73
95°F	260	74	257	74
105°F	293	75	291	76
115°F	324	77	325	77

Charge Verification - Approach Method

- 1- Using the same thermometer, compare liquid temperature to outdoor ambient temperature.

Approach Temperature = Liquid temperature minus ambient temperature.

- 2- Approach temperature should be 7°F ± 1 (3.8°C ± 0.5). An approach temperature greater than this value indicates an undercharge. An approach temperature less than this value indicates an overcharge.
- 3- Do not use the approach method if system pressures do not match pressures in tables 11 through 17. The approach method is not valid for grossly over or undercharged systems.

V-MAINTENANCE

The unit should be inspected once a year by a qualified service technician.

⚠ WARNING



Electric shock hazard. Can cause injury or death. Before attempting to perform any service or maintenance, turn the electrical power to unit OFF at disconnect switch(es). Unit may have multiple power supplies.

⚠ CAUTION

Label all wires prior to disconnection when servicing controls. Wiring errors can cause improper and dangerous operation. Verify proper operation after servicing.

⚠ WARNING

Product contains fiberglass wool. Disturbing the insulation in this product during installation, maintenance, or repair will expose you to fiberglass wool. Breathing this may cause lung cancer. (Fiberglass wool is known to the State of California to cause cancer.) Fiberglass wool may also cause respiratory, skin, and eye irritation. To reduce exposure to this substance or for further information, consult material safety data sheets available from address shown on unit nameplate or contact your supervisor.

A-Filters

Units are equipped with four 18 X 24 X 2" filters. Filters should be checked and replaced when necessary with filters of like kind and size. Take note of air flow direction marking on filter frame when reinstalling filters. See figure 14.

B-Lubrication

All motors are lubricated at the factory. No further lubrication is required.

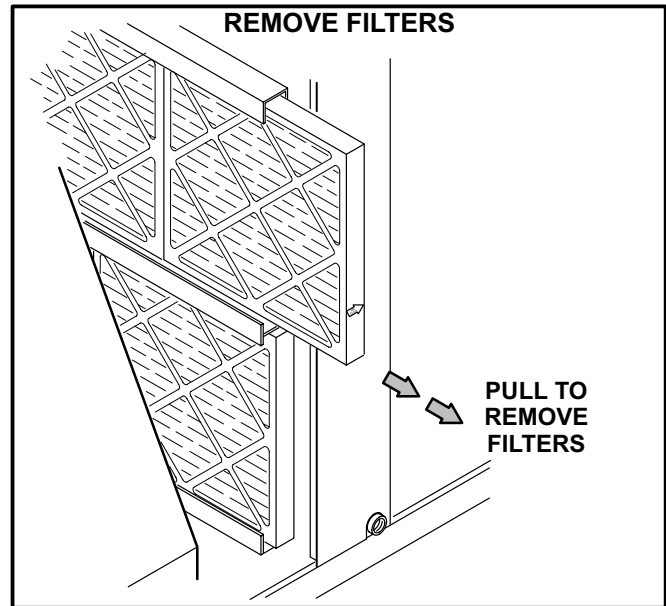

FIGURE 14

NOTE-Filters must be U.L.C. certified or equivalent for use in Canada.

C-Evaporator Coil

Inspect and clean coil at beginning of each cooling season. Clean using mild detergent or commercial coil cleanser. Flush coil and condensate drain with water taking care not to get insulation, filters and return air ducts wet.

D-Condenser Coil

Clean condenser coil annually with detergent or commercial coil cleaner and inspect monthly during the cooling season.

Condenser coils are made of one, two, and three formed slabs. Dirt and debris may become trapped between the slabs. To clean between slabs, carefully separate coil slabs and wash them thoroughly. See figure 15. Flush coils with water following cleaning.

Note - Remove all screws and gaskets prior to cleaning procedure and replace upon completion.

E-Supply Blower Wheel

Annually inspect supply air blower wheel for accumulated dirt or dust. Turn off power before attempting to remove access panel or to clean blower wheel.

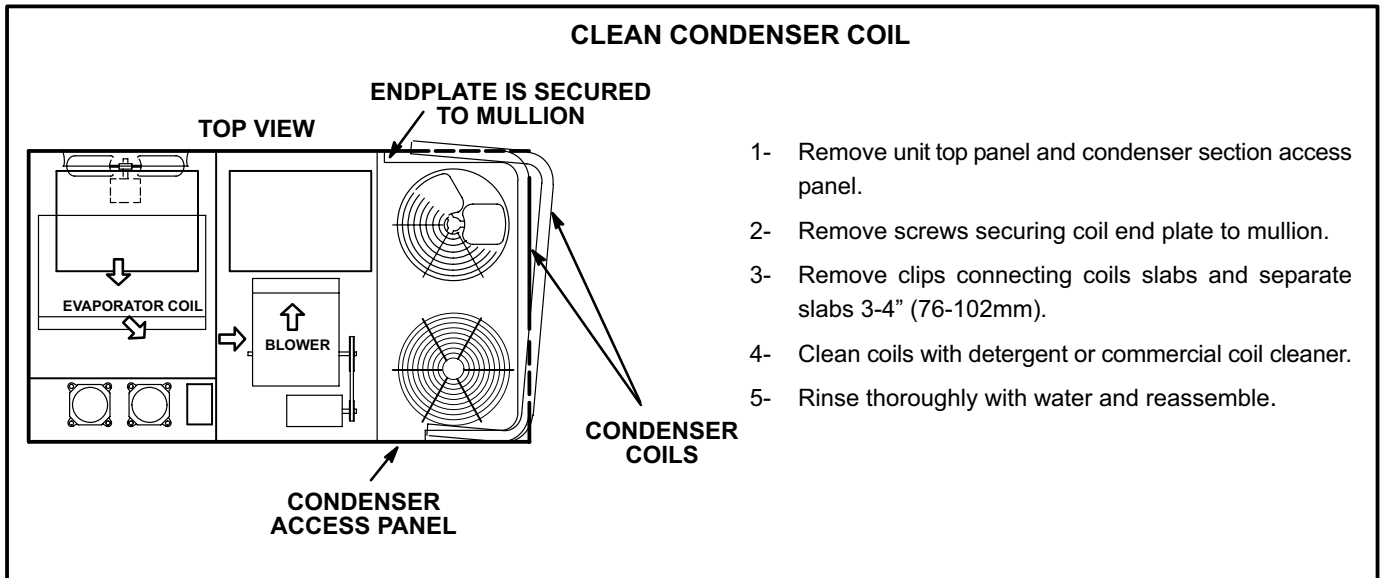

FIGURE 15

VI-ACCESSORIES

The accessories section describes the application of most of the optional accessories which can be factory or field installed to the TCA units.

A-LARMF and LARMFH Mounting Frames

TCA090/150

When installing either the TCA units on a combustible surface for downflow discharge applications, the Lennox LARMF10/15 14-inch or 24-inch (356 mm or 610mm) height roof mounting frame is used. The roof mounting frames are recommended in all other applications but not required. If the TCA units are not mounted on a flat (roof) surface, they **MUST** be supported under all edges and under the middle of the unit to prevent sagging. The units **MUST** be mounted level within 1/16" per linear foot or 5mm per meter in any direction.

The assembled LARMF mounting frame is shown in figure 16. Refer to the roof mounting frame installation instructions for details of proper assembly and mounting. The roof mounting frame **MUST** be squared to the roof and level before mounting. Plenum system **MUST** be installed before the unit is set on the mounting frame. Typical roof curbing and flashing is shown in figure 17. Refer to the roof mounting frame installation instructions for proper plenum construction and attachment.

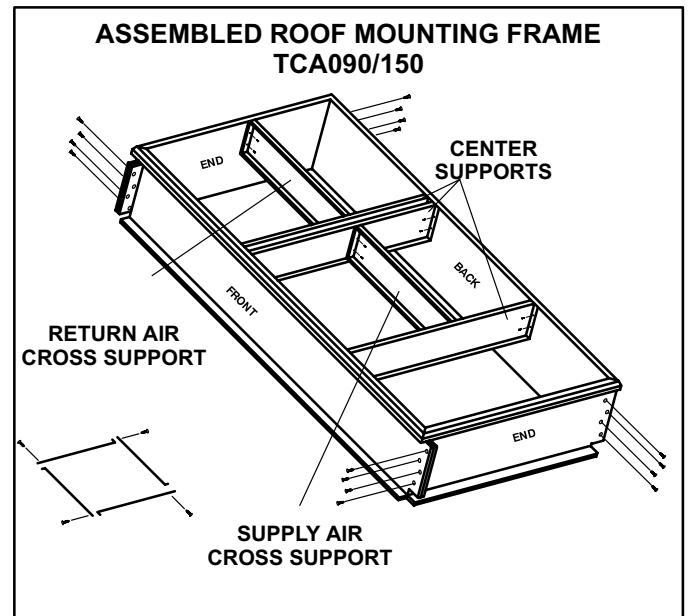

FIGURE 16

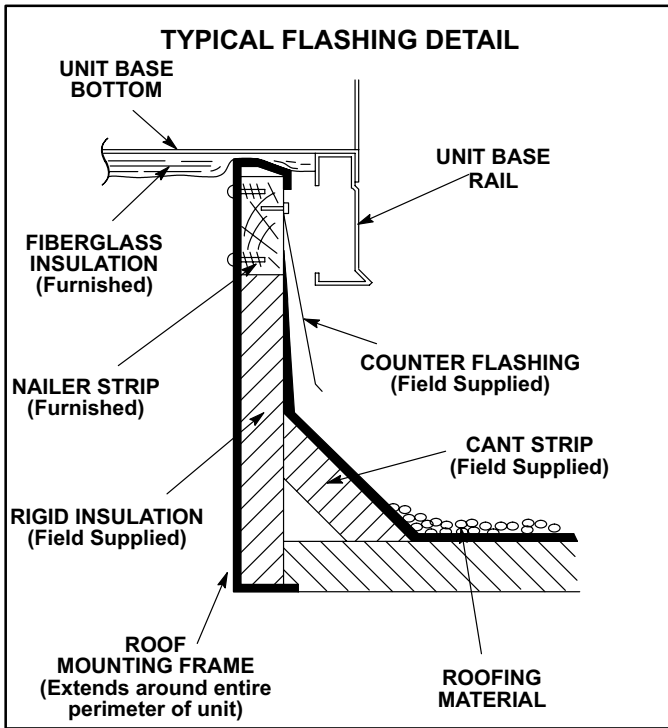

FIGURE 17

B-Transitions

Optional supply/return transitions LASRT08/10 is available for use with the TCA 7.5 ton units and LASRT10/12 is available for the 7.5 and 10 ton units, utilizing optional LARMF10/15 roof mounting frames. TCA 12.5 ton units will use LASRT15 with LARMF10/15 roof mounting frame. Transition must be installed in the LARMF mounting frame before mounting the unit to the frame. Refer to the manufacturer's instructions included with the transition for detailed installation procedures.

C-LAOAD(M) Outdoor Air Dampers

LAOAD(M)10/15 used on TCA090S/150 units consists of a set of dampers which may be manually or motor (M) operated to allow up to 25 percent outside air into the system at all times (see figure 18). Either air damper can be installed in TCA units. Washable filter supplied with the outdoor air dampers can be cleaned with water and a mild detergent. It should be sprayed with Filter Handicoater when dry prior to reinstallation. Filter Handicoater is R.P. Products coating no. 418 and is available as Lennox Part No. P-8-5069.

D-Supply and Return Diffusers (all units)

Optional flush mount diffuser/return FD11 and extended mount diffuser/return RTD11 are available for use with all TCA units. Refer to manufacturer's instructions included with transition for detailed installation procedures.

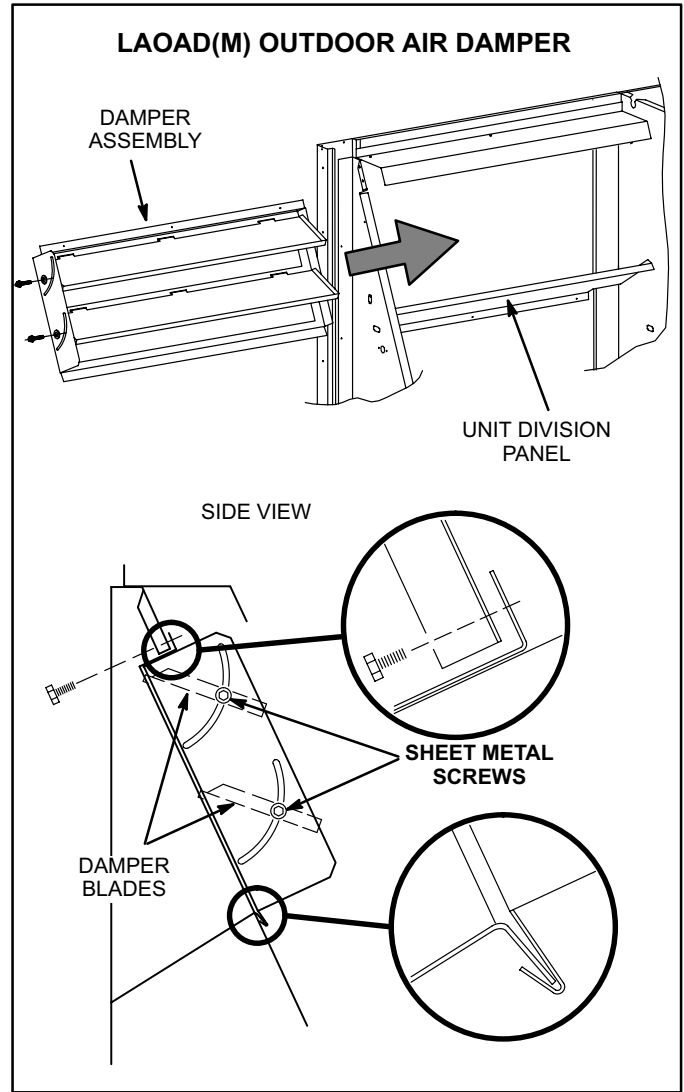

FIGURE 18

E-TAREMD Economizer (Field or Factory Installed)

Unit may contain an optional factory-installed three-position economizer equipped with an A6 enthalpy control and an A7 outdoor enthalpy sensor. The three-position economizer opens fully to use outdoor air for free cooling when temperature is suitable and opens to minimum position during the occupied time period.

The A6 enthalpy control is located in the economizer access area. See figure 19. The A7 enthalpy sensor is located on the division panel between horizontal supply and return air sections.

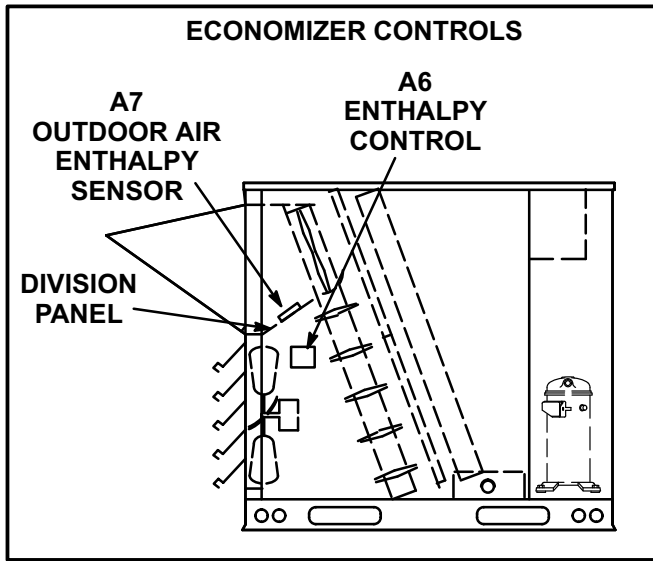

FIGURE 19

Optional Sensors

An optional differential sensor (A62) may be used with the A7 outdoor sensor to compare outdoor air temperature to return air temperature. When the outdoor air temperature is below the return air temperature, outdoor air is used for free cooling.

An optional mixed air sensor (R1) may be used to modulate dampers to 55°F (13°C) discharge air.

An optional IAQ sensor (A63) may be used to lower operating costs by controlling outdoor air based on CO₂ level or room occupancy (also called demand control ventilation or DCV). Damper minimum position can be set lower than traditional minimum air requirements; dampers open to traditional ventilation requirements when CO₂ level reaches DCV (IAQ) setpoint.

Refer to instructions provided with sensors for installation.

A6 Enthalpy Control LED's

A steady green Free Cool LED indicates that outdoor air is suitable for free cooling.

When an optional IAQ sensor is installed, a steady green DCV LED indicates that the IAQ reading is higher than setpoint requiring more fresh air. See figure 20.

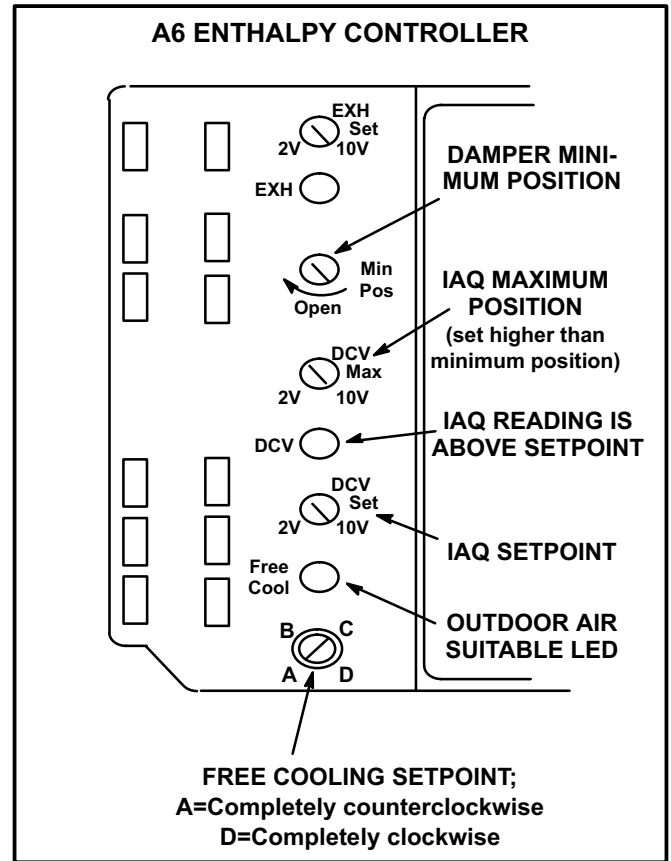

FIGURE 20

Free Cooling Setpoint

Outdoor air is considered suitable when temperature and humidity are less than the free cooling setpoints shown in table 18. Setting A is recommended. See figure 20. At setting A, free cooling will be energized when outdoor air is approximately 73°F (23°C) and 50% relative humidity. If indoor air is too warm or humid, lower the setpoint to B. At setting B, free cooling will be energized at 70°F (21°C) and 50% relative humidity.

When an optional A62 differential sensor is installed, turn A6 enthalpy control free cooling setpoint potentiometer completely clockwise to position "D".

**TABLE 18
ENTHALPY CONTROL SETPOINTS**

Control Setting	Free Cooling Setpoint At 50% RH
A	73° F (23° C)
B	70° F (21° C)
C	67° F (19° C)
D	63° F (17° C)

Damper Minimum Position

NOTE - A jumper is factory-installed between TB1 A1 and A2 terminals to maintain occupied status (allowing minimum fresh air). When using an electronic thermostat or energy management system with an occupied/unoccupied feature, remove jumper.

- 1- Set thermostat to occupied mode if the feature is available. Make sure jumper is in place between A45 control board TB1 terminals A1 and A2 if using a thermostat which does not have the feature.
- 2- Rotate MIN POS SET potentiometer to approximate desired fresh air percentage.

Note - Damper minimum position can be set lower than traditional minimum air requirements when an IAQ sensor is specified. Dampers will open to DCV MAX setting (if CO2 is above setpoint) to meet traditional ventilation requirements.

- 3- Measure outdoor air temperature. Mark the point on the bottom line of chart 1 and label the point "A" (40°F, 4°C shown).
- 4- Measure return air temperature. Mark that point on the top line of chart 1 and label the point "B" (74°F, 23°C shown).
- 5- Measure mixed air (outdoor and return air) temperature. Mark that point on the top line of chart 1 and label point "C" (70°F, 21°C shown).
- 6- Draw a straight line between points A and B.
- 7- Draw a vertical line through point C.

- 8- Draw a horizontal line where the two lines meet. Read the percent of fresh air intake on the side.
- 9- If fresh air percentage is less than desired, adjust MIN POS SET potentiometer higher. If fresh air percentage is more than desired, adjust MIN POS SET potentiometer lower. Repeat steps 3 through 8 until calculation reads desired fresh air percentage.

DCV Set and Max Settings

Adjust settings when an optional IAQ sensor is installed.

The DCV SET potentiometer is factory-set at approximately 50% of the potentiometer range. Using a standard 1-2000ppm CO₂ sensor, dampers will start to open when the IAQ sensor reads approximately 1000ppm. Adjust the DCV SET potentiometer to the approximate setting specified by the controls contractor. Refer to figure 20.

The DCV MAX potentiometer is factory-set at approximately 50% of the potentiometer range or 6VDC. Dampers will open approximately half way when CO₂ rises above setpoint. Adjust the DCV MAX potentiometer to the approximate setting specified by the controls contractor. Refer to figure 20.

Note - DCV Max must be set higher than economizer minimum position setting for proper demand control ventilation.

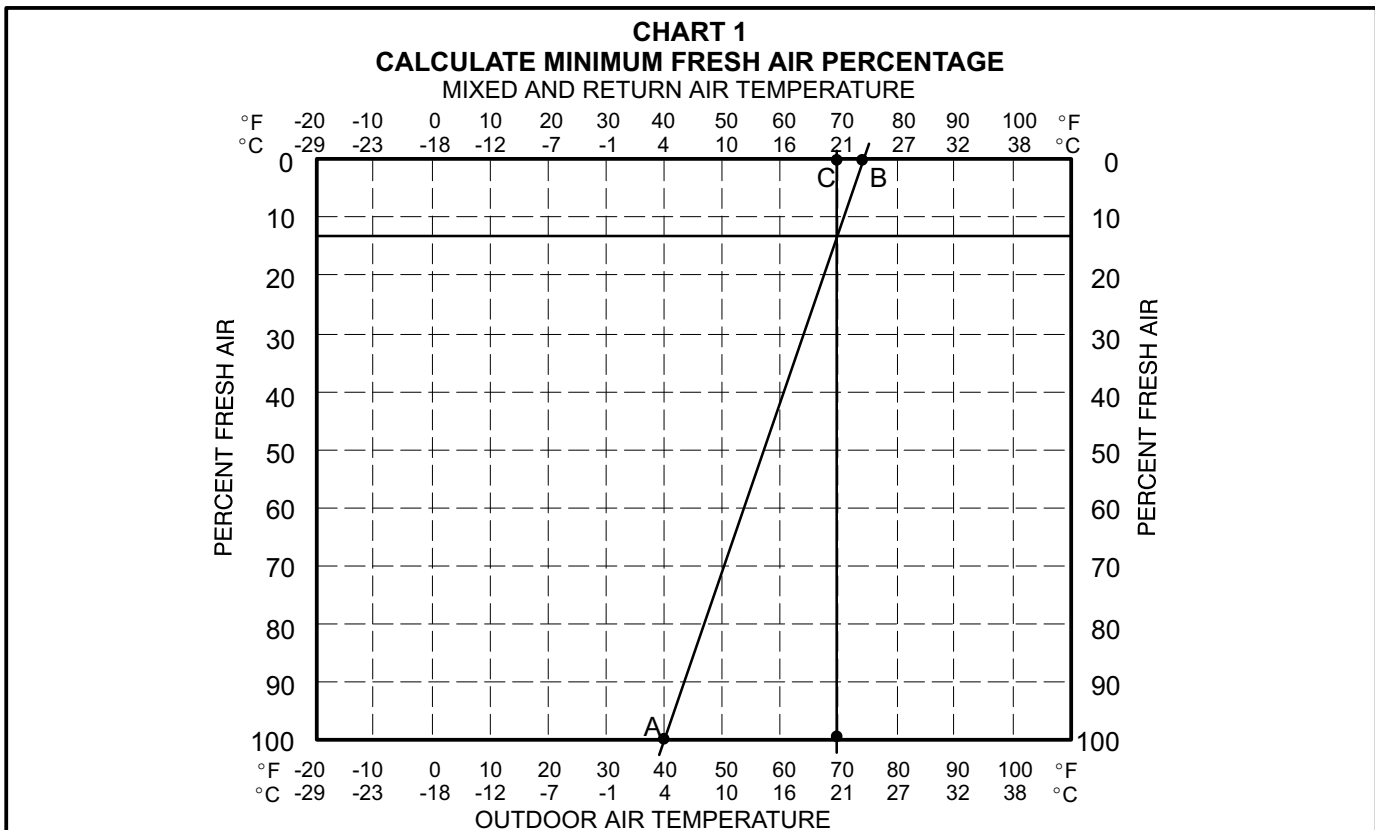

Economizer Operation

The occupied time period is determined by the thermostat or energy management system.

Outdoor Air Not Suitable:

During the unoccupied time period dampers are closed. During the occupied time period a cooling demand will open dampers to minimum position and mechanical cooling functions normally.

During the occupied time period dampers will open to DCV MAX when IAQ reading is above setpoint (regardless of thermostat demand or outdoor air suitability).

Outdoor Air Suitable:

See table 19 for economizer operation with a standard two-stage thermostat.

During the occupied period, dampers will open to DCV MAX when IAQ reading is above setpoint (regardless of thermostat demand or outdoor air suitability). DCV MAX will NOT override damper full-open position. When an R1 mixed air sensor for modulating dampers is installed, DCV MAX may override damper free cooling position when occupancy is high and outdoor air temperatures are low. If R1 senses discharge air temperature below 45°F (7°C), dampers will move to minimum position until discharge air temperature rises to 48°F (9°C).

B-Outdoor Air Dampers

Optional manual and motorized outdoor air dampers provide fresh outdoor air. The motorized damper assembly opens to minimum position during the occupied time period and remains closed during the unoccupied period. Manual damper assembly is set at installation and remains in that position. See figure 21.

Set damper minimum position in the same manner as economizer minimum position. Adjust motorized damper position using the thumbwheel on the damper motor. See figure 22. Manual damper fresh air intake percentage can be determined in the same manner.

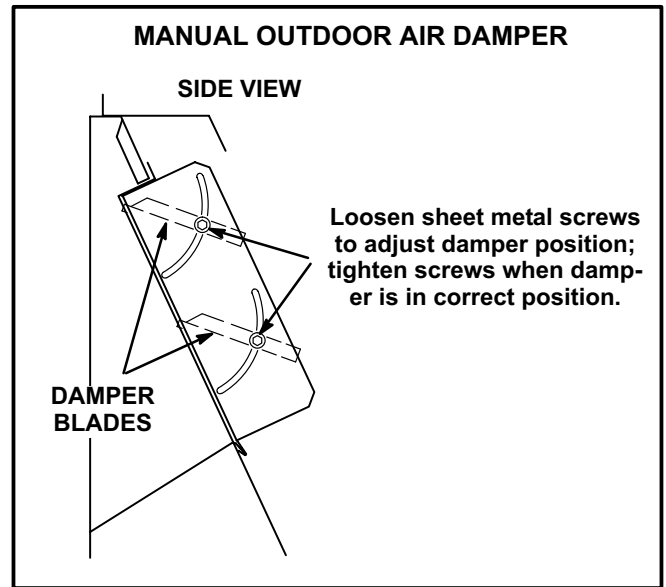

FIGURE 21

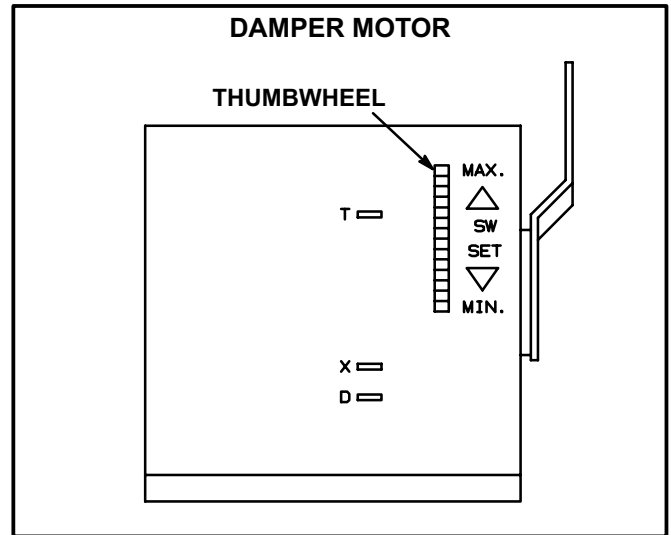

FIGURE 22

**TABLE 19
ECONOMIZER OPERATION
OUTDOOR AIR IS SUITABLE FOR FREE COOLING – FREE COOL LED “ON”**

THERMOSTAT DEMAND	DAMPER POSITION		MECHANICAL COOLING
	UNOCCUPIED	OCCUPIED	
OFF	CLOSED	CLOSED	NO
G	CLOSED	MINIMUM	NO
Y1	OPEN*	OPEN*	NO
Y2	OPEN*	OPEN*	STAGE 1

*Dampers will modulate to maintain 55°F (13°C) supply air when an R1 mixed air sensor is installed.

F-LAGED(H) Gravity Exhaust Dampers

LAGED(H)10/15 dampers (figure 23) available for TCA090/150 units are used in downflow and LAGEDH are used in horizontal air discharge applications. LAGED(H) gravity exhaust dampers are installed in the return air plenum. The dampers must be used any time an economizer or power exhaust fans are applied to TCA series units.

Gravity exhaust dampers allow exhaust air to be discharged from the system when an economizer and/or power exhaust is operating. Gravity exhaust dampers also prevent outdoor air infiltration during unit off cycle. See installation instructions for more detail.

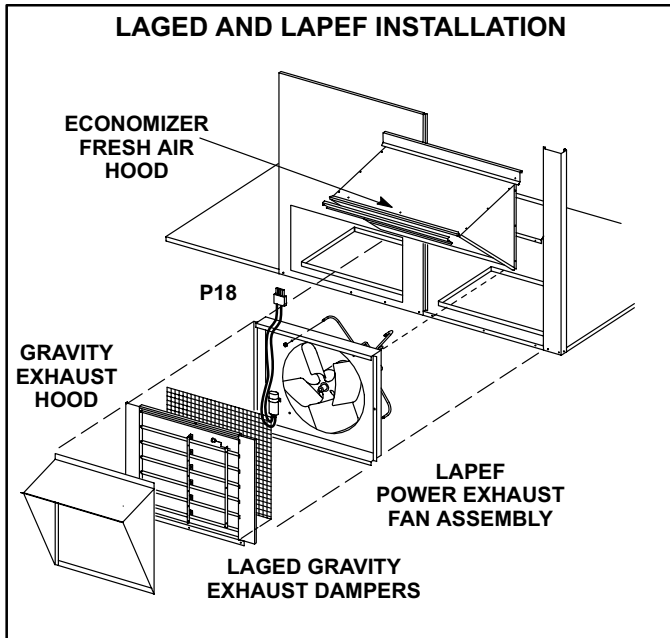

FIGURE 23

G-LAPEF Power Exhaust Fans (all units)

LAPEF10/15 available for TCA090/150 units are power exhaust fans used in downflow applications only. LAPEF fans require optional down-flow gravity exhaust dampers and LA-REMD economizers. Power exhaust fans provide exhaust air pressure relief and also run when return air dampers are closed and supply air blowers are operating. Figure 23 shows location of the LAPEF. See installation instructions for more detail.

H-Control Systems

Three different types of control systems may be used with the TCA series units. All thermostat wiring is connected to terminal block TB1 located in the control box of the unit. Each thermostat has additional control options available. See thermostat installation instructions for more detail.

1- Electro-mechanical thermostat (13F06)

The electro-mechanical thermostat is a two stage heat / two stage cool thermostat with dual temperature levers. A non-switching or manual system switch subbase may be used.

2- Electronic thermostat (see price book)

Any two stage heat / two stage cool electronic thermostat may be used.

3- Honeywell T7300 thermostat (60L59)

The Honeywell T7300 thermostat is a programmable, internal or optional remote temperature sensing thermostat. The T7300 provides occupied and unoccupied changeover control.

I-Smoke Detectors A17 and A64

Photoelectric smoke detectors are a factory installed option. The smoke detectors can be installed in the supply air section (A64), return air section (A17), or in both the supply and return air section.

J-Blower Proving Switch S52

The blower proving switch monitors blower operation and locks out the unit in case of blower failure. The switch is N.O. and closes at .14" W.C. (34.9 Pa) The switch is mounted on the upper left hand corner of the blower deck.

K-Dirty Filter Switch S27

The dirty filter switch senses static pressure increase indicating a dirty filter condition. The switch is N.O. and closes at 1" W.C. (248.6 Pa) The switch is mounted on the top filter channel corner.

VII-Wiring Diagrams and Sequence of Operation

TCA090/150 UNIT DIAGRAM

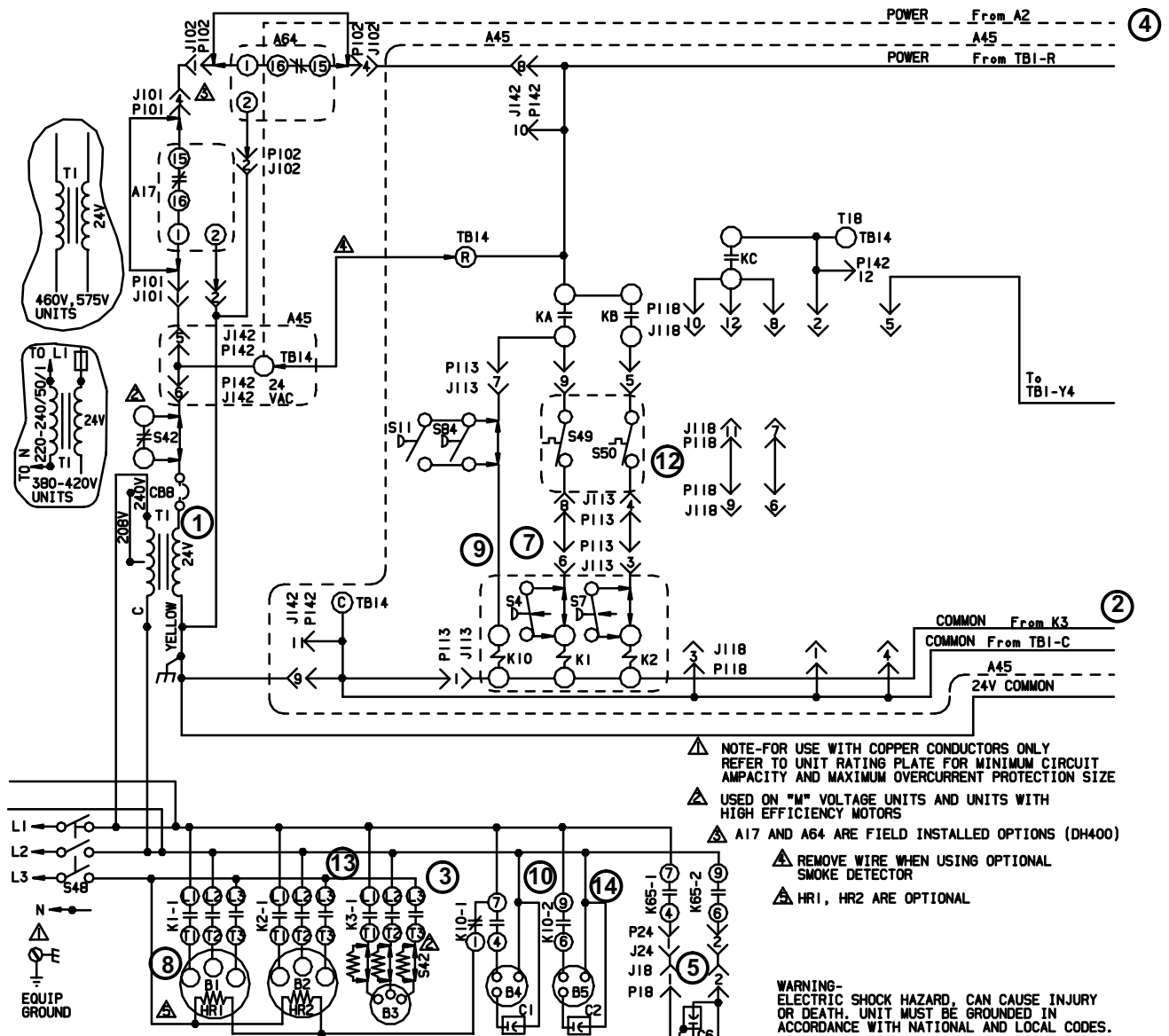

KEY	DESCRIPTION	COMPONENT	KEY	DESCRIPTION	COMPONENT
A17	DETECTOR-SMOKE		K1-1	CONTACTOR-COMPRESSOR 1	
A45	CONTROL-MODULE		K2-1	CONTACTOR-COMPRESSOR 2	
A64	DETECTOR-SMOKE,SUPPLY AIR		K3-1	RELAY/CONTACTOR-BLOWER	
B1	COMPRESSOR 1		K10-1	RELAY-OUTDOOR FAN 1	
B2	COMPRESSOR 2		K65-1,2	RELAY-EXHAUST FAN	
B3	MOTOR-BLOWER		P18	PLUG-EXHAUST FAN COMPT	
B4	MOTOR-OUTDOOR FAN 1		P24	PLUG-EXHAUST FAN	
B5	MOTOR-OUTDOOR FAN 2		P101	PLUG-SMOKE DETECTOR,RETURN AIR	
B10	MOTOR-EXHAUST FAN 1		P102	PLUG-SMOKE DETECTOR,SUPPLY AIR	
C1	CAPACITOR-OUTDOOR FAN 1		P113	PLUG-BLOWER COOL 1 CONTROL	
C2	CAPACITOR-OUTDOOR FAN 2		P118	PLUG-COMPRESSOR 3 & 4 CONTROL	
C6	CAPACITOR-EXHAUST FAN 1		P132	PLUG-B10 EXHAUST FAN MOTOR	
CB9	CIRCUIT BREAKER-TRANS T1		P142	PLUG-ECONOMIZER HARNESS	
HRI	HEATER-COMPRESSOR 1		S4	SWITCH-LIMIT,HI PRESS,COMP 1	
HR2	HEATER-COMPRESSOR 2		S7	SWITCH-LIMIT,HI PRESS,COMP 2	
J18	JACK-EXHAUST FAN COMPT		S11	SWITCH-LOW PRESS,LOW AMB KIT	
J24	JACK-EXHAUST FAN		S42	OVERLOAD-RELAY,BLOWER MOTOR	
J101	JACK-SMOKE DETECTOR,RETURN AIR		S48	SWITCH-DISCONNECT	
J102	JACK-SMOKE DETECTOR,SUPPLY AIR		S49	SWITCH-FREEZESTAT,COMPRESSOR 1	
J113	JACK-BLOWER & COOL 1 CONT		S50	SWITCH-FREEZESTAT,COMPRESSOR 2	
J118	JACK-COMPRESSOR 3 & 4 CONTROL		S84	SWITCH-LOW PRESS,LOW AMB,COMP 2	
J132	JACK-BLOWER,EXHAUST FAN MTR		T1	TRANSFORMER-CONTROL	
J142	JACK-ECONOMIZER HARNESS		TB14	TERMINAL STRIP-CLASS II VOLTAGE	

DISCONNECT ALL POWER BEFORE SERVICING
 ————— DESIGNATES OPTIONAL WIRING
 - - - - - CLASS II FIELD WIRING

WIRING DIAGRAM		1/04
COMBINATION PACKAGED/ROOFTOP		
TCA, TGA-090, 102, 120, 150-G, J, M, Y		
HEAT/COOL SECTION B1		
Supersedes Form No.	New Form No.	
	534, 476W	
© 2004	Litho U.S.A.	

TCA090/150 SEQUENCE OF OPERATION

Power:

1. Line voltage from unit disconnect energizes transformer T1. T1 provides 24VAC power to terminal strip TB1. TB1 provides 24VAC to the unit cooling, heating and blower controls.

Blower Operation:

2. The main control module receives a demand from thermostat terminal G. A45 energizes blower contactor K3 with 24VAC.
3. N.O. K3-1 closes, energizing blower B3.

Economizer Operation:

4. The economizer control module receives a demand and energizes exhaust fan relay K65 with 24VAC at 50% outside air damper open (adjustable).
5. N.O. K65-1 and N.O. K65-2 both close, energizing exhaust fan motor B10.

1st Stage Cooling (compressor B1)

6. First stage cooling demand Y1 and G is energized by the thermostat. G energizes blower.
7. 24VAC is routed through TB1 on main control module A45. A45 proves N.C. freeze stat S49, and optional N.C. high pressure switch S4. Compressor contactor K1 is energized.
8. N.O. contacts K1-1 close energizing compressor B1.
9. Optional N.O. low ambient switch S11 closes to energize condenser fan relay K10.
10. N.O. contacts K10-1 close energizing condenser fan B4 .

2nd Stage Cooling (compressor B2 is energized)

11. Second stage cooling demand energizes Y2.
12. 24VAC is routed through TB1 on module A45. A45 proves N.C. freeze stat S50 and optional N.C. high pressure switch S7. Compressor contactor K2 is energized.
13. N.O. K2-1 closes energizing compressor B2.
14. Optional N.O. low ambient switch S84 closes energizing contacts K10-2. K10-2 close energizing condenser fan B5.

EHA-7.5, 15, 22.5, 30, 45 60kW G, J, M VOLTAGE

KEY	DESCRIPTION
DL2	DELAY-ELECTRIC HEAT
F3	FUSE-ELECTRIC HEAT
F4	FUSE-UNIT
HE1	ELEMENT-ELECT HEAT 1
HE2	ELEMENT-ELECT HEAT 2
HE3	ELEMENT-ELECTRIC HEAT 3
HE4	ELEMENT-ELECTRIC HEAT 4
J2	JACK-ELECTRIC HEAT
J7	JACK-ELECT HT SUR-BASE KIT
J14	JACK-WARM UP ADAPTOR
J88	JACK-CONTROL MODULE
K9-1	RELAY-HEAT
K15-1	CONTACTOR-ELECTRIC HT 1
K16-1	CONTACTOR-ELECTRIC HT 2
P2	PLUG-ELECTRIC HEAT
P7	PLUG-ELECT HT SUR-BASE KIT
P12	PLUG
P14	PLUG
S15	SWITCH-LIMIT, PRIMARY, ELECT HT
S20	SWITCH-LIMIT, SECONDARY ELECT HT
TB2	TERMINAL STRIP-UNIT
TB3	TERMINAL STRIP-ELECTRIC HEAT

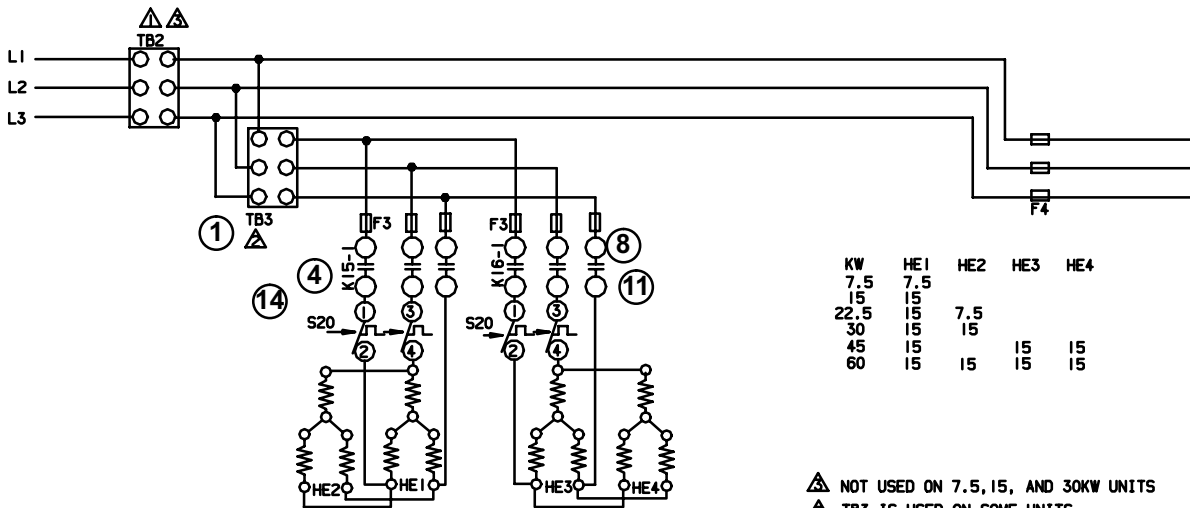
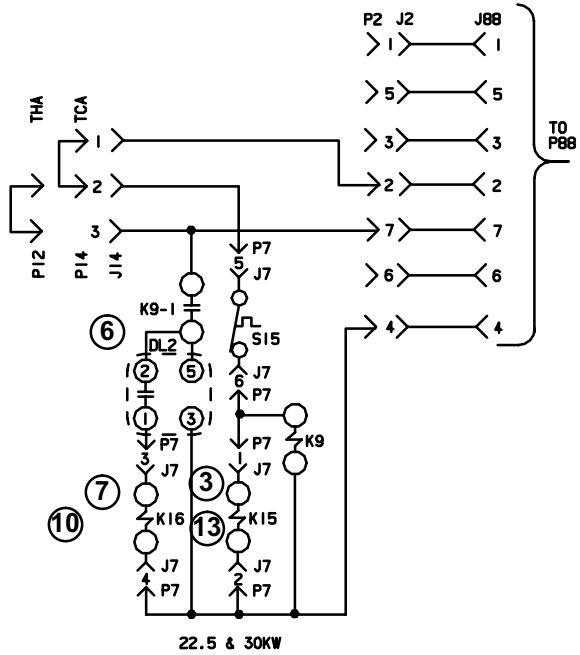

KW	HE1	HE2	HE3	HE4
7.5	7.5			
15	15			
22.5	15	7.5		
30	15	15		
45	15	15	15	15
60	15	15	15	15

- ⚠ NOT USED ON 7.5, 15, AND 30KW UNITS
- ⚠ TB3 IS USED ON SOME UNITS
- ⚠ TB2, S48 OR CB10 MAY BE USED

WIRING DIAGRAM		2/04
HEATING-ELECTRIC		
EHA-7.5, 15, 22.5, 30, 45, 60-1, 2-G, J, M FOR USE WITH TCA UNITS		
HEATING SECTION-A4		
Supersedes Form No. 534,472W	New Form No. 534,648W	

© 2004

Litko U.S.A.

Sequence of Operation -EHA 7.5, 15, 22.5, 30, 45, 60 kW - Y and G, J, M

NOTE: This sequence of operation is for all Electric Heat kW ratings Y through J voltages. Each step of operation is numbered and can be followed in sequence on the diagrams. Operation for G, J, and M voltages will be the same.

HEATING ELEMENTS:

- 1 - Terminal Strip TB3 is energized when the unit disconnect closes. TB3 supplies line voltage to electric heat elements HE1 through HE7. Each element is protected by fuse F3.

FIRST STAGE HEAT:

- 2 - Heating demand initiates at W1 in thermostat.
- 3 - 24VAC is routed through from main control module A45. After A45 proves N.C. primary limit S15 and secondary limit S20, the electric heat contactor K15 is energized.
- 4 - N.O. contacts K15-1 close allowing the first bank of elements to be energized.

SECOND STAGE HEAT:

- 5 - With the first stage heat operating, an additional heating demand initiates at W2 in the thermostat.
- 6 - Relay K9 is energized. N.O. contacts K9-1 close energizing timer DL2.
- 7 - After a 30 second delay, DL2 closes energizing contactor K16.
- 8 - N.O. contacts K16-1 close allowing the second bank of elements to be energized.

END OF SECOND STAGE HEAT:

- 9 - Heating demand is satisfied. Terminal W2 in the thermostat is de-energized.
- 10 - Electric heat contactor K16 is de-energized.
- 11 - The second set of electric heat elements are de-energized.

END OF FIRST STAGE HEAT:

- 12 - Heating demand is satisfied. Terminal W1 in the thermostat is de-energized.
- 13 - Electric heat contactor K15 is de-energized.
- 14 - The first set of electric heat elements are de-energized.

ELECTRONIC OR ELECTROMECHANICAL THERMOSTAT

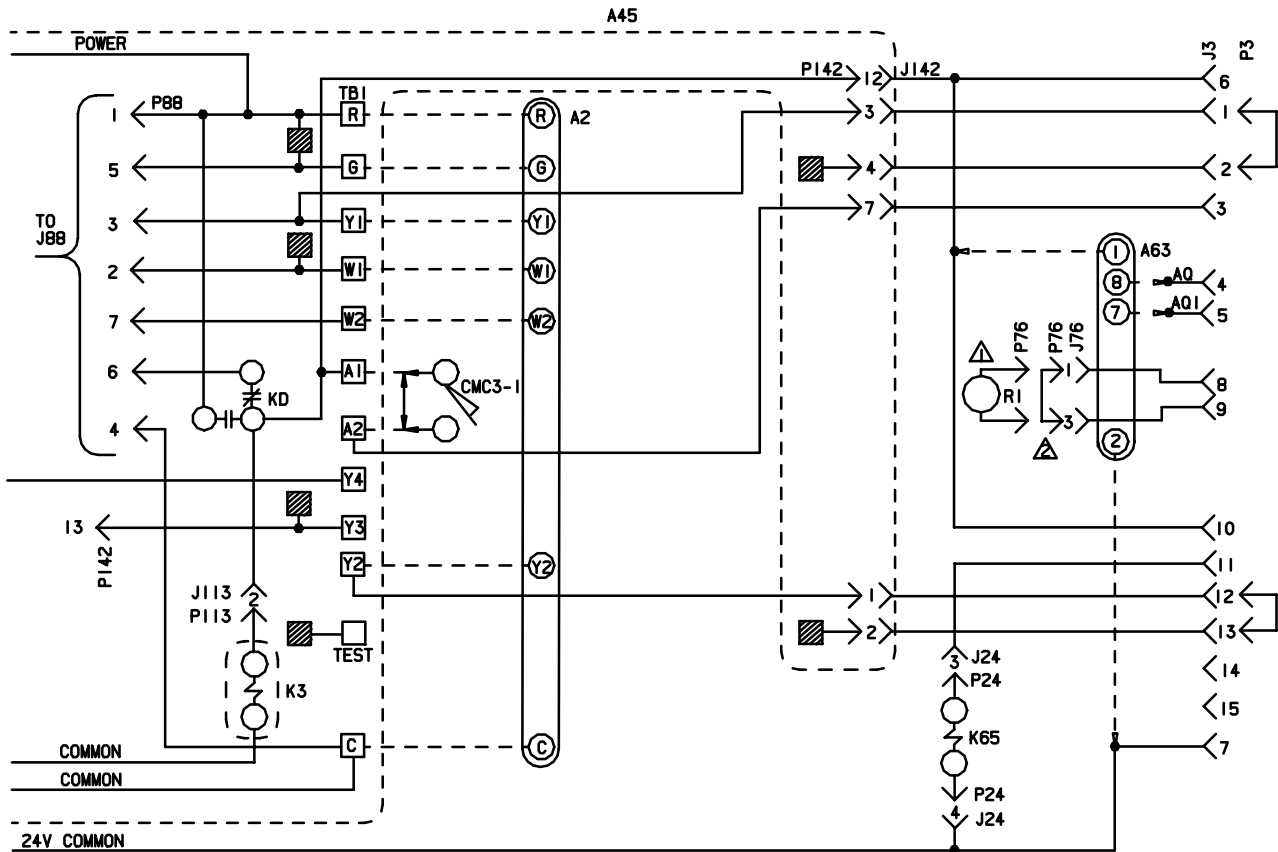

KEY	DESCRIPTION
	COMPONENT
A2	SENSOR-ELECTRONIC
A45	CONTROL-MODULE
A63	SENSOR-CO2
CMC3-1	CLOCK-TIME
J3	JACK-UNIT, ECONOMIZER
J24	JACK-EXHAUST FAN
J76	JACK-SENSOR, ECONOMIZER
J113	JACK-BLOWER & COOL I CONTROL
J142	JACK-ECONOMIZER HARNESS
K3	RELAY/CONTACTOR-BLOWER
K65	RELAY-EXHAUST FAN
P3	PLUG-LESS ECONOMIZER
P24	PLUG-EXHAUST FAN
P76	PLUG-SENSOR, ECONOMIZER
P88	PLUG-HEAT CONTROL
P113	PLUG-BLOWER & COOL I CONTROL
P142	PLUG-ECONOMIZER HARNESS
R1	SENSOR-MIXED OR SUPPLY AIR
TB1	TERMINAL STRIP-24V CLASS II

△ R1 IS USED WITH OPTIONAL MODULATING ECONOMIZER FIELD KIT

△ REMOVE JUMPER WHEN R1 IS USED

THERMOSTAT HEAT ANTICIPATION SETTING 0.1 AMP

▨ INDICATES MICRO PROCESSOR
 ——— DESIGNATES OPTIONAL WIRING
 - - - - - CLASS II FIELD WIRING

WIRING DIAGRAM	12/03
ACCESSORIES	
ELECTROMECHANICAL OR ELECTRONIC THERMOSTAT FOR TCA/TGA UNITS	
TEMPERATURE CONTROL SECTION CI	
Supersedes Form No.	New Form No. 534,484W

© 2003

Litho U.S.A.

POWER:

- Terminal strip TB1 found on the main control module A45 energize thermostat components with 24VAC.

OPERATION:

- The main control module A45 receives data from the electronic thermostat A2 (Y1, Y2, W1, W2, G, OCP) A45 energizes the appropriate components for heat or cool demand.

"T" SERIES ECONOMIZER

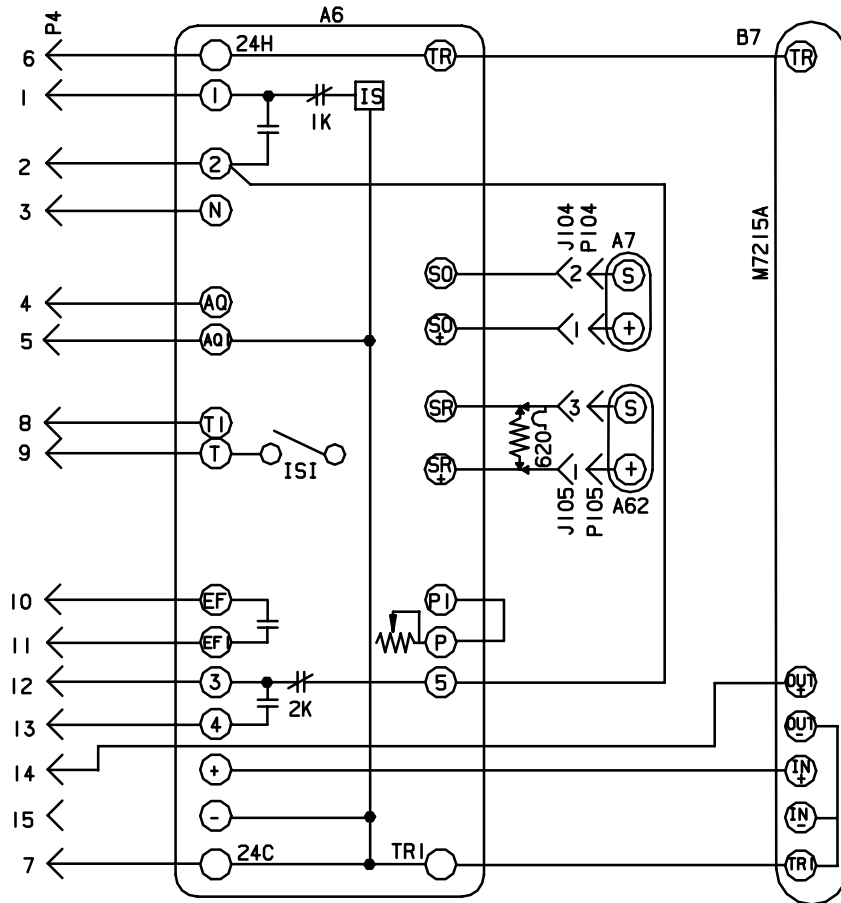

DESIGNATES OPTIONAL WIRING
 CLASS II FIELD WIRING

KEY	DESCRIPTION
	COMPONENT
A6	CONTROL-SOLID STATE ENTHALPY
A7	SENSOR-SOLID STATE ENTHALPY
A62	SENSOR-ENTHALPY, INDOOR
B7	MOTOR-DAMPER, ECONOMIZER
J104	JACK-SENSOR, OUTDOOR ENTHALPY
J105	JACK-SENSOR, RETURN AIR ENTHALPY
P4	PLUG-ECONOMIZER
P104	PLUG-SENSOR, OUTDOOR ENTHALPY
P105	PLUG-SENSOR, RETURN AIR ENTHALPY

WIRING DIAGRAM	11/03
ACCESSORIES	
ECONOMIZER FOR TCA/TGA UNITS	
ECONOMIZER SECTION D1	
Supersedes Form No.	New Form No.
	534,485W

© 2003

Litho U.S.A.

SEQUENCE OF OPERATION

POWER:

1. Terminal strip TB1 found on main control module A45 energizes the economizer components with 24VAC.

OPERATION:

2. Enthalpy sensor A7 and A62 (if differential enthalpy is used) communicates to the economizer control module A6 when to power the damper motor B7.
3. Economizer control module A6 supplies B7 with 0 - 10 VDC to control the positioning of economizer.
4. The damper actuator provides 2 to 10 VDC position feedback.