

INSTALLATION, OPERATING AND SERVICE INSTRUCTIONS CGS-A™ SERIES GAS BOILER

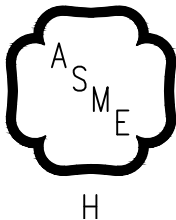

BEFORE INSTALLATION: READ THIS MANUAL

SAVE THESE INSTRUCTIONS

Installing contractor and homeowner should read and be informed as to the proper installation and operation of this boiler. The manufacturer will not be responsible for improper installation or operation. This manual and all associated instruction material should be conspicuously posted near the boiler.

For service or repairs to boiler, call your heating contractor. When seeking information on boiler, provide Boiler Model Number and Serial Number as shown on Rating Label.

Boiler Model Number CGS_0A	Boiler Serial Number	Installation Date
Heating Contractor		Phone Number
Address		



New Yorker[®]
RESIDENTIAL HEATING BOILERS

The City of New York requires a Licensed Master Plumber supervise the installation of this product.

The Massachusetts Board of Plumbers and Gas Fitters has approved the Classic CGS-A™ Series boiler. See the Massachusetts Board of Plumbers and Gas Fitters website, http://license.reg.state.ma.us/pubLic/pl_products/pb_pre_form.asp for the latest Approval Code or ask your local Sales Representative.

The Commonwealth of Massachusetts requires this product to be installed by a Licensed Plumber or Gas Fitter.

The following terms are used throughout this manual to bring attention to the presence of hazards of various risk levels, or to important information concerning product life.

DANGER

Indicates an imminently hazardous situation which, if not avoided, will result in death, serious injury or substantial property damage.

CAUTION

Indicates a potentially hazardous situation which, if not avoided, may result in moderate or minor injury or property damage.

WARNING

Indicates a potentially hazardous situation which, if not avoided, could result in death, serious injury or substantial property damage.

NOTICE

Indicates special instructions on installation, operation, or maintenance which are important but not related to personal injury hazards.

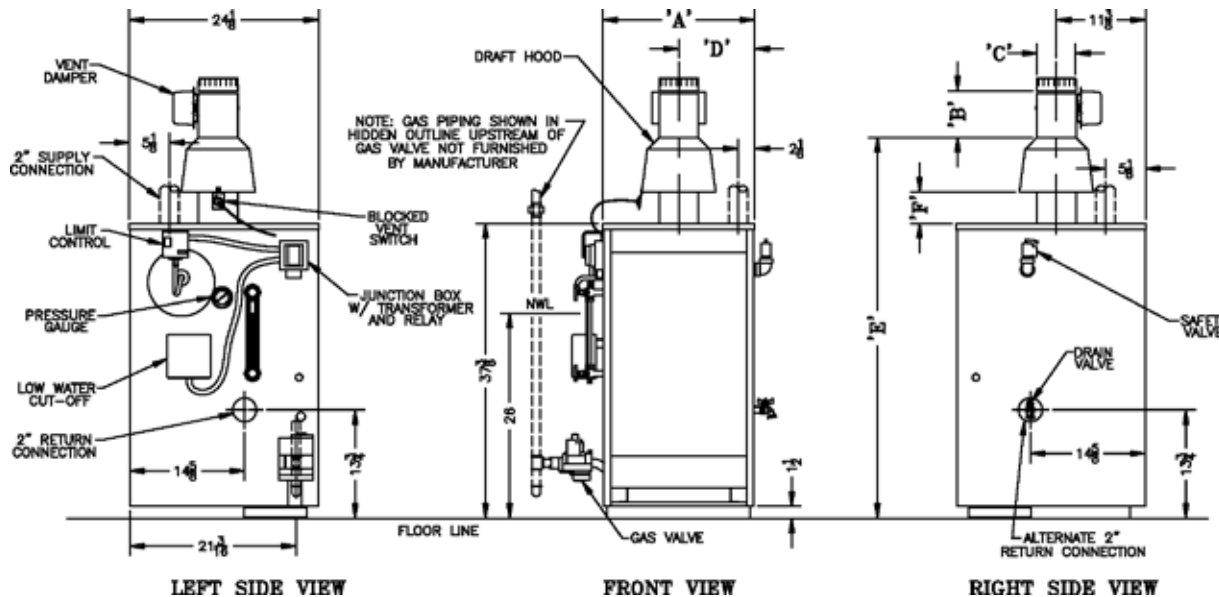

Figure 1: Dimensional Drawing

Table 1: Dimensional Data

Boiler Size	Dimensions (in inches)								Recommended Chimney *		Gas Connection (NPT)	Approx. Shipping Weight
	'A'	'B'	'C'	'D'	'E'		'F'		Round	Square		
					Nat	LP	Nat	LP				
CGS30A	12-3/16	4-3/4	4	6-1/8	53-1/8	53-1/8	9-3/4	9-3/4	4" Dia. x 15 ft.	8" x 8" x 15 ft.	3/4	305 LB
CGS40A	15-3/4	4-3/4	5	7-7/8	50-1/4	50-1/4	6	6	5" Dia. x 15 ft.	8" x 8" x 15 ft.	3/4	370 LB
CGS50A	19-3/8	5-1/4	6	9-3/4	52-1/8	55-1/8	7-1/4	10-1/4	6" Dia. x 15 ft.	8" x 8" x 15 ft.	3/4	440 LB
CGS60A	22-7/8	5-1/4	6	11-1/2	53-3/8	56-3/8	8-1/2	11-1/2	6" Dia. x 15 ft.	8" x 8" x 15 ft.	3/4	502 LB
CGS70A	26-1/2	7-1/2	7	13-1/4	55-7/8	58-7/8	9-3/4	12-3/4	7" Dia. x 15 ft.	8" x 8" x 15 ft.	3/4	566 LB
CGS80A	30	7-1/2	7	15	57-1/8	60-3/4	11	14-1/2	7" Dia. x 15 ft.	8" x 8" x 15 ft.	3/4	650 LB

* 15 Ft. Chimney height is from bottom of Draft Hood opening to top of chimney

Maximum Working Pressure: 15 PSIG, Steam
30 PSIG, Water

Table of Contents

I. Pre-Installation.....	3	VI. Electrical.....	13
II. Unpack Boiler	5	VII. System Start-up	16
III. Steam Piping and Trim	5	VIII. Service	21
IV. Gas Piping.....	8	IX. Repair Parts.....	28
V. Venting	10	Warranty	Back Cover

I. Pre-Installation

WARNING

Carefully read all instructions before installing boiler. Failure to follow all instructions in proper order can cause personal injury or death.

- A. **Inspect shipment** carefully for any signs of damage. All equipment is carefully manufactured, inspected and packed. Our responsibility ceases upon delivery of boiler to carrier in good condition. Any claim for damage or shortage in shipment must be filed immediately against carrier by consignee. No claims for variances or shortages will be allowed by Boiler Manufacturer, unless presented within sixty (60) days after receipt of equipment.
- B. **Installation must conform** to the requirements of the authority having jurisdiction. In the absence of such requirements, installation must conform to *National Fuel Gas Code*, ANSI Z223.1/NFPA 54. Where required by the authority having jurisdiction, the installation must conform to the *Standard for Controls and Safety Devices for Automatically Fired Boilers*, ANSI/ASME CSD-1.
- C. **Boiler is design certified for installation on noncombustible flooring only.** For installation on combustible flooring only when installed on special base listed in Table 2. The boiler must not be installed on carpeting.
- D. **Provide clearance** between boiler jacket and combustible material in accordance with local fire ordinance. Refer to Figure 2 for minimum clearance from combustible material for alcove installation.

Table 2: Special Base for Installation on Combustible Flooring

Boiler Model	Special Base Part Number
CGS30A	61812036
CGS40A	61812046
CGS50A	61812056
CGS60A	61812066
CGS70A	61812076
CGS80A	61812086

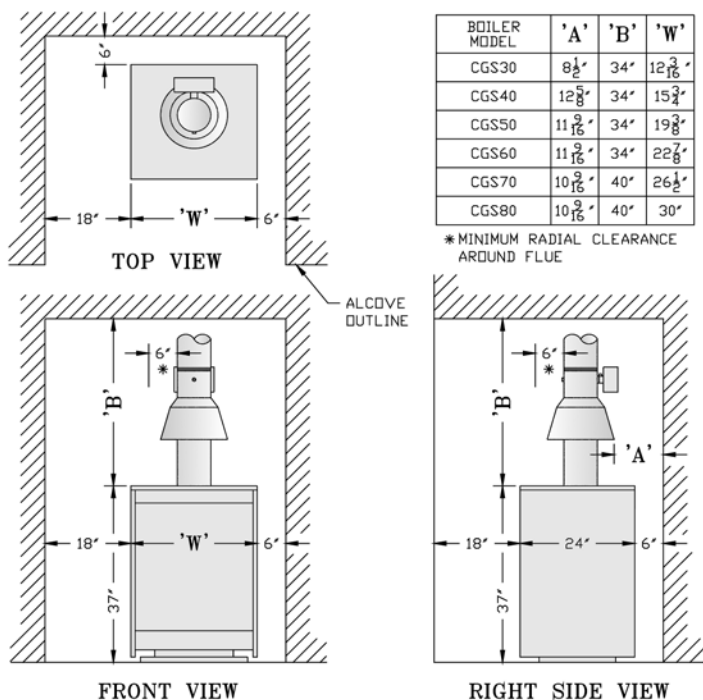

Figure 2: Minimum Clearances to Combustible Construction for Alcove Installation

I. Pre-Installation (continued)

Recommended service clearance is 24 inches from left side, right side and front. Service clearances may be reduced to minimum clearances to combustible materials.

- E. Install on level floor.** For basement installation provide concrete base if floor is not level or if water may be encountered on floor around boiler.
- F. Protect gas ignition system components** from water (dripping, spraying, rain, etc.) during boiler operation and service (circulator replacement, condensate trap, control replacement, etc.).
- G. Provide combustion and ventilation air** in accordance with applicable provisions of local building codes, or "Air for Combustion and Ventilation", of the *National Fuel Gas Code*, ANSI Z223.1/NFPA 54.

WARNING

Adequate combustion and ventilation air must be provided to assure proper combustion.

The following guideline is based on the *National Fuel Gas Code*, ANSI Z223.1/NFPA 54.

1. Determine volume of space (boiler room). Rooms communicating directly with space (through openings not furnished with doors) are considered part of space.
$$\text{Volume [ft}^3\text{]} = \text{Length [ft]} \times \text{Width [ft]} \times \text{Height [ft]}$$
2. Determine Total Input of all appliances in space. Round result to nearest 1,000 Btu per hour (Btuh).
3. Determine type of space. Divide Volume by Total Input.
 - a. If result is greater than or equal to 50 ft³ per 1,000 Btuh, space is considered an *unconfined space*.
 - b. If result is less than 50 ft³ per 1,000 Btuh, space is considered a *confined space*.
4. Determine building type. A building of *unusually tight construction* has the following characteristics:
 - a. Walls and ceiling exposed to outside atmosphere have a continuous water vapor retarder with a rating of 1 perm or less with openings gasketed and sealed, and;
 - b. Weather-stripping has been added on openable windows and doors, and;
 - c. Caulking or sealants applied in joints around window and door frames, between sole plates and floors, between wall-ceiling joints, between wall panels, at plumbing and electrical penetrations, and at other openings.

5. For boiler located in an *unconfined space in a building of other than unusually tight construction*, adequate combustion and ventilation air is normally provided by fresh air infiltration through cracks around windows and doors.
6. For boiler located within *unconfined space in building of unusually tight construction* or within *confined space*, provide outdoor air through two permanent openings which communicate directly or by duct with the outdoors or spaces (crawl or attic) freely communicating with the outdoors. Locate one opening within 12 inches of top of space. Locate remaining opening within 12 inches of bottom of space. Minimum dimension of air opening is 3 inches. Size each opening per following:
 - a. Direct communication with outdoors. Minimum free area of 1 square inch per 4,000 Btu per hour input of all equipment in space.
 - b. Vertical ducts. Minimum free area of 1 square inch per 4,000 Btu per hour input of all equipment in space. Duct cross-sectional area shall be same as opening free area.
 - c. Horizontal ducts. Minimum free area of 1 square inch per 2,000 Btu per hour input of all equipment in space. Duct cross-sectional area shall be same as opening free area.
7. Ventilation Duct Louvers and Grilles. Equip outside openings with louvers to prevent entrance of rain and snow, and screens to prevent entrance of insects and rodents. Louvers and grilles must be fixed in open position or interlocked with equipment to open automatically before burner operation. Screens must not be smaller than ¼ inch mesh.

Alternate method for boiler located within confined space. Use indoor air if two permanent openings communicate directly with additional space(s) of sufficient volume such that combined volume of all spaces meet criteria for unconfined space. Size each opening for minimum free area of 1 square inch per 1,000 Btu per hour input of all equipment in spaces, but not less than 100 square inches.

Consider the blocking effect of louvers, grilles and screens when calculating the opening size to provide the required free area. If free area of louver or grille is not known, assume wood louvers have 20-25 percent free area and metal louvers and grilles have 60-75 percent free area.

- H. Do not install boiler where gasoline** or other flammable vapors or liquids, or sources of hydrocarbons (i.e. bleaches, cleaners, chemicals, sprays, paint removers, fabric softeners, etc.) are used or stored.

II. Unpack Boiler

CAUTION

Do not drop boiler. Do not bump boiler jacket against floor.

- A.** Move boiler to approximate installed position.
- B.** Remove crate.
1. Remove nails and staples from crate.
 2. Remove four carriage bolts holding boiler to skid.
 3. Remove boiler from skid using $\frac{3}{4}$ inch pipe rollers.
 - a. Roll boiler to rear of skid. Handle boiler jacket carefully to avoid damage.
 - b. Lower rear of boiler to floor.
 - c. Tilt boiler, remove skid at front of boiler, and lower front of boiler to floor. Do not drop boiler.
- C.** Move boiler to permanent location. When using special base for installation on combustible floor:

1. Place base on floor with insulated surface facing upward and part number facing forward.
2. Position base to provide minimum clearances to combustible walls. See Figure 3. Secure in place.
3. Place boiler on base. Center boiler on base to provide minimum clearances to combustible walls and ceiling. See Figure 2.

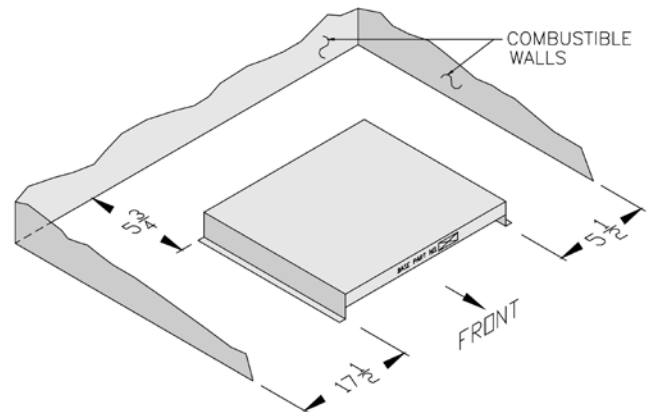

Figure 3: Special Base Installation

III. Steam Piping and Trim

NOTICE

Before using copper for steam piping, consider the following characteristics of copper piping:

- 1) **High coefficient of thermal expansion can induce mechanical stresses and cause expansion/contraction noises if not accounted for in the piping system design and installation,**
- 2) **High heat transfer rate (heat loss) of uninsulated copper piping must be included in the normal piping and pickup factors used to size the boiler,**
- 3) **Soldering or brazing pastes and fluxes that end up in the system can cause poor heat transfer, surging, an unsteady water line and wet steam if not thoroughly removed during boil out procedure and,**
- 4) **Galvanic corrosion of the adjoining metal may occur due to dissimilar metals in certain water chemistries if dielectric unions are not used.**

WARNING

Failure to properly pipe boiler may result in improper operation and damage to boiler or structure.

- A. Design and install boiler and system piping** to prevent oxygen contamination of boiler water.
- Oxygen contamination sources are system leaks requiring addition of makeup water, fittings, and oxygen permeable materials in distribution system. Eliminate oxygen contamination by repairing system leaks, repairing fittings, and using nonpermeable materials in distribution system.

- B. Boiler equipped with McDonnell & Miller 67 Low Water Cutoff Only.** Assemble gauge glass and low water cutoff as shown in Figure 5. Follow instructions packed with low water cutoff.

1. Affix Blow-Down Card to Jacket Left Side Panel adjacent to low water cutoff.
2. Provide blow-down discharge piping.

- C. Remove Jacket Front Panel.** Remove parts bag from vestibule area.

- D. Install Safety Valve** in Tapping 'E'. See Figure 4. Use $\frac{3}{4}$ NPT x 3" nipple and $\frac{3}{4}$ elbow provided. **Safety Valve must be installed with spindle in vertical position.**

III. Steam Piping and Trim (continued)

WARNING

Safety valve discharge piping must be piped near floor to eliminate potential of severe burns. Do not pipe in any area where freezing could occur. Do not install any shut-off valves.

Table 3: Purpose of Tappings

Tapping	Size	Purpose
A	2"	30 - 70: Plugged, Optional Second Supply 80: Second Supply
B	3/4"	Pressure Gauge (bushed to 1/4")
C	1/2"	Gauge Glass / Float LWCO
D	2"	Return (Standard)
E	3/4"	Safety Valve
F	2"	Drain Valve Return (Alternate)
G	2"	Supply
H	3/4"	Limit
K	3/4"	Probe Low Water Cutoff (Plugged with McDonnell & Miller 67 LWCO)

E. Install Drain Valve in Tapping 'F'. See Figure 4.

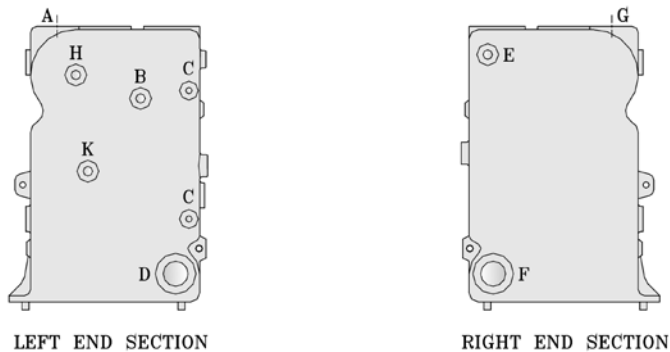

Figure 4: Purpose of Tappings

F. Connect system supply and return piping to boiler.

- See Figure 6. Also consult Residential Hydronic Heating Installation and Design I=B=R Guide. Maintain minimum 1/2 inch clearance from piping to combustible materials.

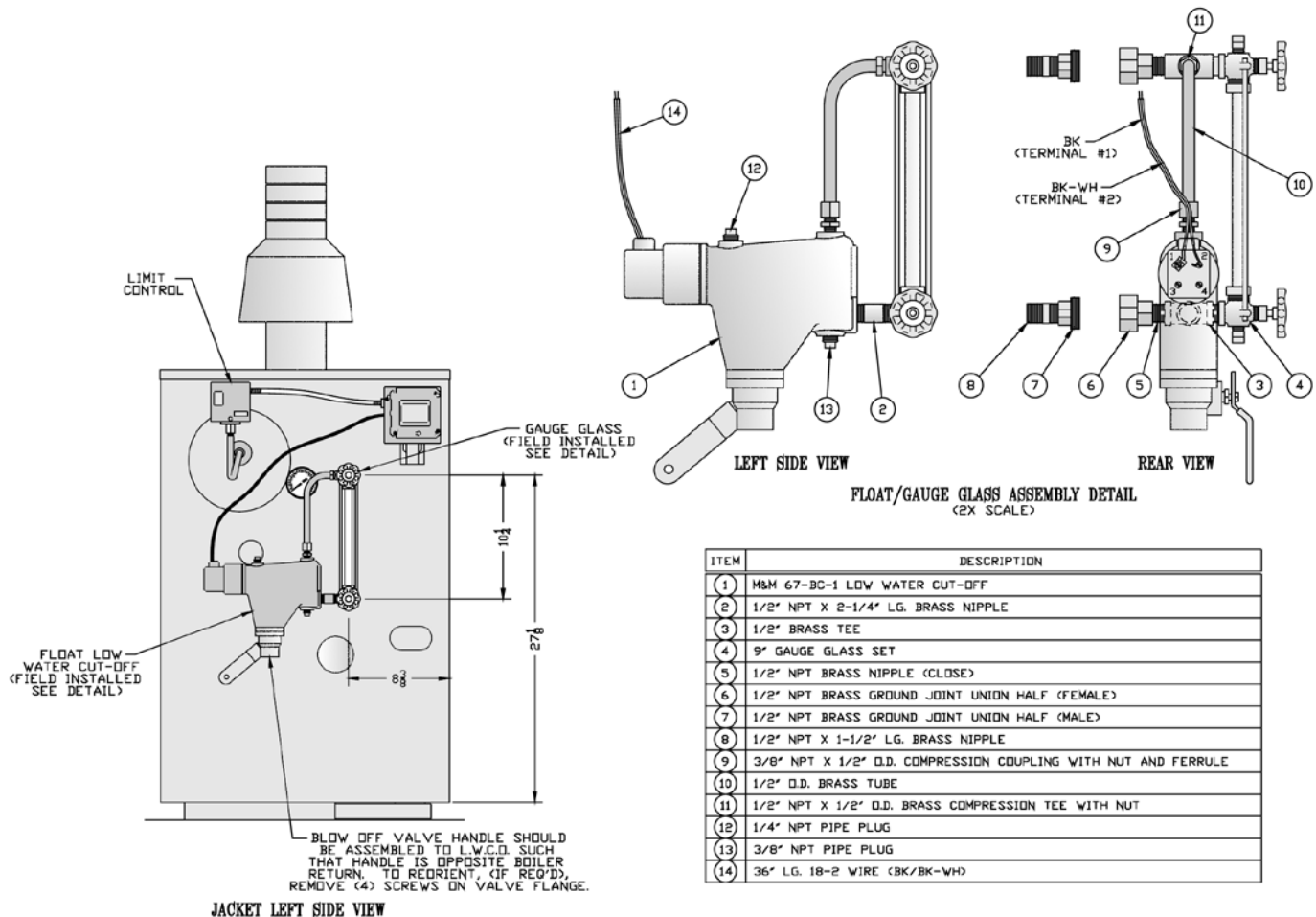

Figure 5: Assembly Diagram for McDonnell & Miller 67 Low Water Cutoff

III. Steam Piping and Trim (continued)

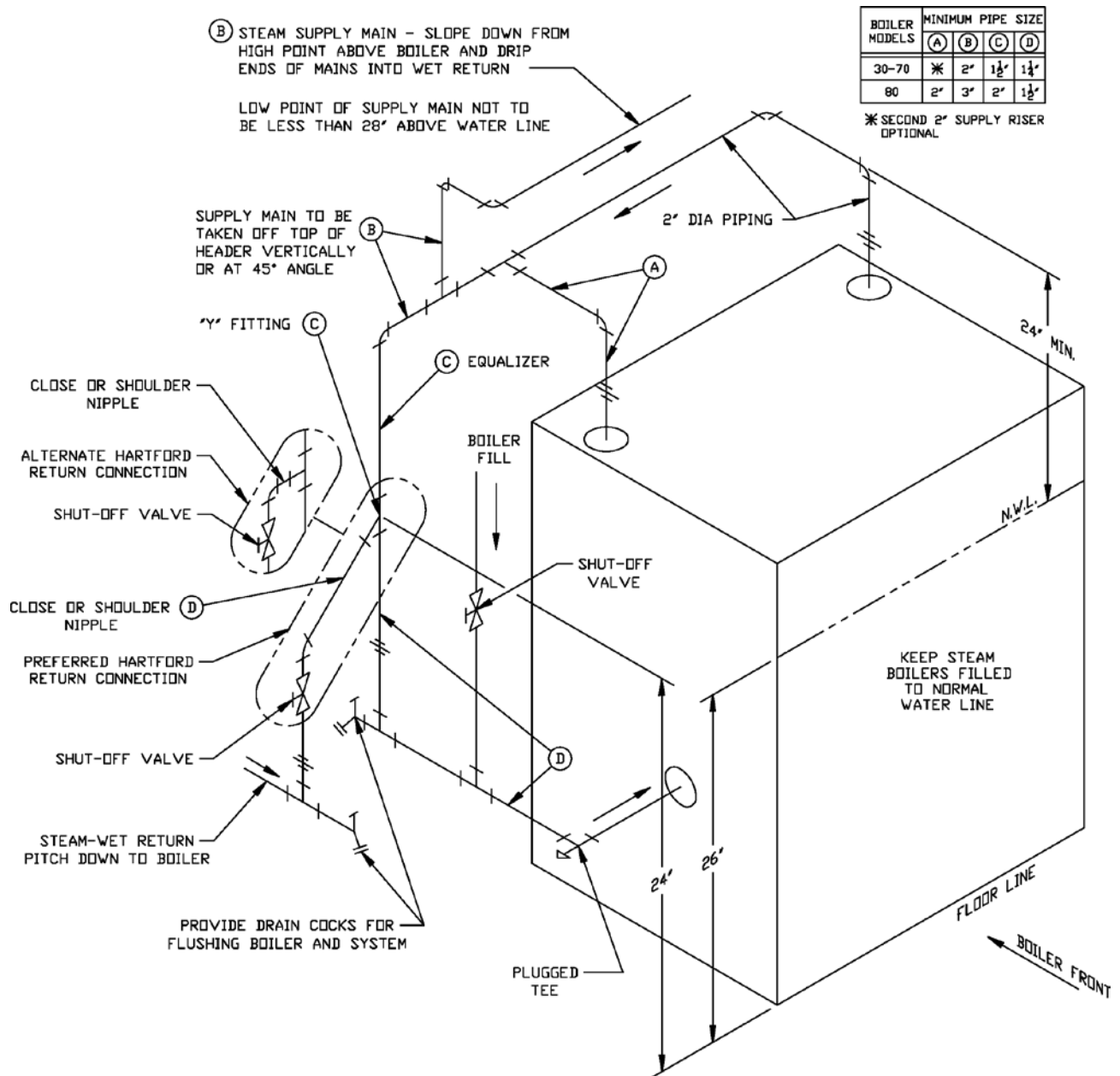

Figure 6: Recommended Boiler Piping for Gravity Return

- If boiler is used in connection with refrigeration systems, boiler must be installed with chilled medium piped in parallel with heating boiler using appropriate valves to prevent the chilled medium from entering the boiler. See Figure 7. Also consult I=B=R, "Residential Hydronic Heating Installation and Design Guide".
- Boiler piping system of hot water boiler connected to heating coils located in air handling units where they may be exposed to refrigerated air circulation must be equipped with flow control valves or other automatic means to prevent gravity circulation of boiler water during cooling cycle.

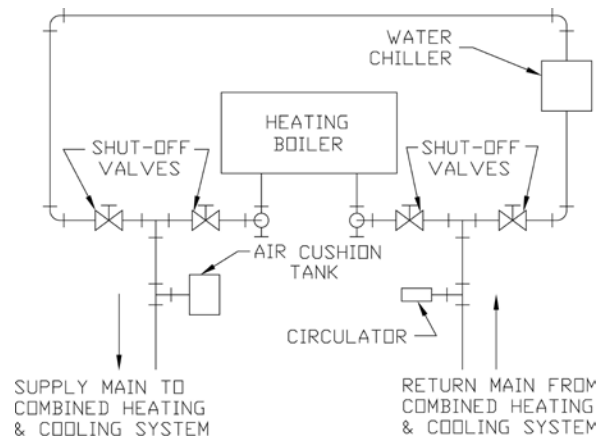

Figure 7: Recommended Piping for Combination Heating and Cooling (Refrigeration) Systems

IV. Gas Piping

A. Size gas piping. Design system to provide adequate gas supply to boiler. Consider these factors:

1. Allowable pressure drop from point of delivery to boiler. Maximum allowable system pressure is $\frac{1}{2}$ psig. Actual point of delivery pressure may be less; contact gas supplier for additional information. Minimum gas valve inlet pressure is listed on rating label.
2. Maximum gas demand. Table 4 lists boiler input rate. Also consider existing and expected future gas utilization equipment (i.e. water heater, cooking equipment).
3. Length of piping and number of fittings. Refer to Table 5 for maximum capacity of Schedule 40 pipe. Table 6 lists equivalent pipe length for standard fittings.
4. Corrections for the specific gravity of natural gas can be found in Table 7.

Table 4: Rated Input

Boiler Model Number	Input Rate [cubic feet per hour]		Gas Connection Size
	Natural	LP/Propane	
CGS30S	70	28	$\frac{3}{4}$
CGS40A	105	42	$\frac{3}{4}$
CGS50A	140	56	$\frac{3}{4}$
CGS60A	175	70	$\frac{3}{4}$
CGS70A	210	84	$\frac{3}{4}$
CGS80A	245	98	$\frac{3}{4}$

For materials or conditions other than those listed above, refer to *National Fuel Gas Code*, ANSI Z223.1/NFPA 54, or size system using standard engineering methods acceptable to authority having jurisdiction.

B. Connect boiler gas valve to gas supply system.

1. Use methods and materials in accordance with local plumbing codes and requirements of gas supplier. In absence of such requirements, follow *National Fuel Gas Code*, ANSI Z223.1/NFPA 54.
2. Use thread (joint) compounds (pipe dope) resistant to action of liquefied petroleum gas.
3. Install sediment trap, ground-joint union and manual shut-off valve upstream of boiler gas control valve. See Figure 8.

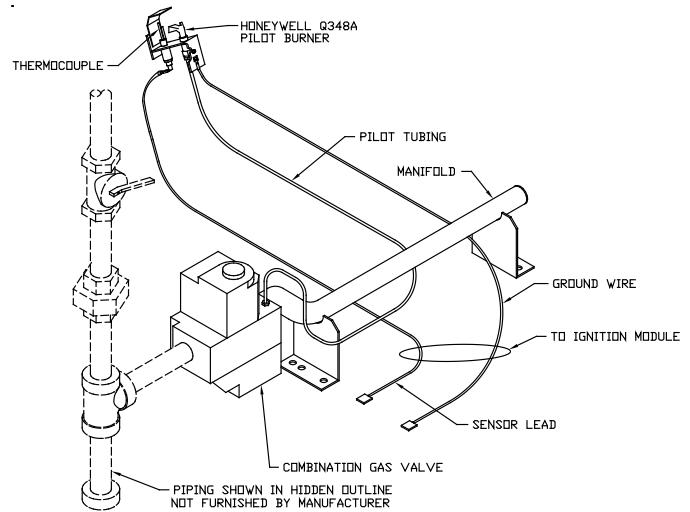

Figure 8: Pilot and Gas Piping,

Table 5: Maximum Capacity of Schedule 40 Pipe in CFH For Natural Gas Pressures of 0.5 psig or Less

Length\ [Feet]	0.3 inch w.c. Pressure Drop				0.5 inch w.c. Pressure Drop			
	$\frac{1}{2}$	$\frac{3}{4}$	1	$1\frac{1}{4}$	$\frac{1}{2}$	$\frac{3}{4}$	1	$1\frac{1}{4}$
10	132	278	520	1,050	175	360	680	1,400
20	92	190	350	730	120	250	465	950
30	73	152	285	590	97	200	375	770
40	63	130	245	500	82	170	320	660
50	56	115	215	440	73	151	285	580
60	50	105	195	400	66	138	260	530
70	46	96	180	370	61	125	240	490
80	43	90	170	350	57	118	220	460
90	40	84	160	320	53	110	205	430
100	38	79	150	305	50	103	195	400

IV. Gas Piping (continued)

Table 6: Fitting Equivalent Lengths

Fitting	Nominal Pipe Size			
	½	¾	1	1¼
45° Ell	0.7	1.0	1.2	1.6
90° Ell	1.6	2.1	2.6	3.5
Tee (As Elbow)	3.1	4.1	5.2	6.9

- All above ground gas piping upstream from manual shut-off valve must be electrically continuous and bonded to a grounding electrode. Do not use gas piping as grounding electrode. Refer to *National Electrical Code*, ANSI/NFPA 70.

C. Pressure test. The boiler and its gas connection must be leak tested before placing boiler in operation.

- Protect boiler gas control valve. For all testing over ½ psig, boiler and its individual shutoff valve must be disconnected from gas supply piping. For testing at ½ psig or less, isolate boiler from gas supply piping by closing boiler's individual manual shutoff valve.

Table 7: Specific Gravity Correction Factors for Natural Gas

Specific Gravity	Correction Factor	Specific Gravity	Correction Factor
0.50	1.10	1.30	1.07
0.55	1.04	1.40	1.04
0.60	1.00	1.50	1.00
0.65	0.96	1.60	0.97
0.70	0.93	1.70	0.94
0.75	0.90		
0.80	0.87		

- Locate leaks using approved combustible gas detector, soap and water, or similar nonflammable solution. Do not use matches, candles, open flames, or other ignition source.

V. Venting

A. Install vent system in accordance with local building codes; or local authority having jurisdiction; or *National Fuel Gas Code*, ANSI Z223.1/NFPA 54, Part 7, Venting of Equipment. Install any of the following for this Classic CGS-A Series Category I, draft hood equipped appliance:

1. Type B or Type L gas vent. Install in accordance with listing and manufacturer's instructions.
2. Masonry or metal chimney. Build and install in accordance with local building codes; or local authority having jurisdiction; or *Standard for Chimneys, Fireplaces, Vents, and Solid Fuel Burning Appliances*, ANSI/NFPA 211.
Masonry chimney must be lined with approved clay flue lining or listed chimney lining system.
3. Single wall metal vent. Allowed by ANSI Z223.1/NFPA 54 under very restrictive conditions.
4. Do not use cellular core PVC (ASTM F891), cellular core CPVC, or Radel® (polyphenolsulfone).
5. Do not cover non-metallic vent pipe and fittings with thermal insulation. Note: Non-metallic vent cannot be used with this boiler.

B. Inspect chimney and remove any obstructions or restrictions. Clean chimney if previously used for solid or liquid fuel-burning appliances or fireplaces.

DANGER

Inspect existing chimney before installing boiler. Failure to clean or replace perforated pipe or tile lining will cause severe injury or death.

C. Install Draft Hood without modification on outlet of flue collector. See Figure 1. Secure with sheet metal screws.

WARNING

Do not alter boiler draft hood or place any obstruction or non-approved damper in the breeching or vent system. Flue gas spillage can occur. ETL certification will become void.

D. Install Blocked Vent Switch. The Blocked Vent Switch Assembly shipped taped to top of boiler includes power cord and switch attached to mounting bracket.

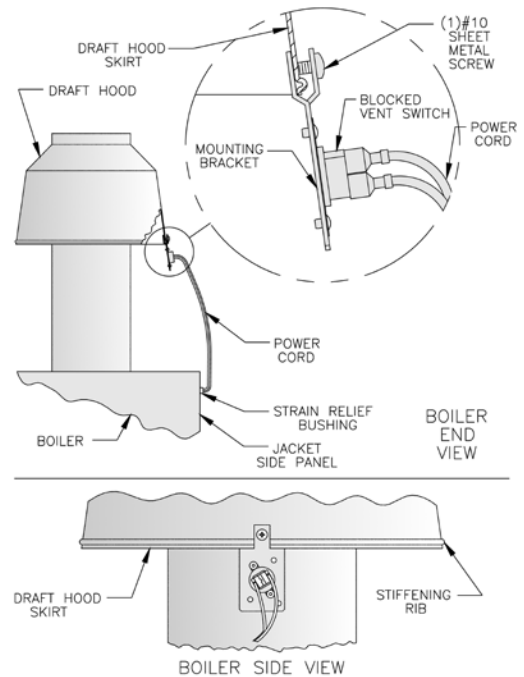

Figure 9: Blocked Vent Switch Installation

1. Untape Blocked Vent Switch Assembly from top of boiler. Uncoil power cord.
2. Pinch black strain relief bushing installed in Jacket Right Side Panel to dislodge bushing from jacket. Pull out enough power cord so Blocked Vent Switch Assembly reaches near side of Draft Hood skirt. Do not pull out more power cord than necessary.
3. Position mounting bracket onto lower edge of Draft Hood skirt. Locate center tooth (with #10 sheet metal screw) on outside and other two teeth inside Draft Hood skirt. See Figure 9.
4. Slide mounting bracket tight against lower edge of Draft Hood skirt. Position #10 sheet metal screw above skirt's stiffening rib.
5. Secure bracket in position by tightening #10 sheet metal screw against outer surface of Draft Hood skirt.
6. Insert excess power cord through Jacket Right Side Panel hole. Remove slack.
7. Position strain relief bushing around power cord. Pinch bushing's two halves together and snap back into hole in Jacket Right Side Panel.
8. Verify power cord, mounting bracket and Blocked Vent Switch are secure and located as shown in Figure 9.

V. Venting (continued)

WARNING

Failure to properly install and use this Blocked Vent Switch may result in property damage, personal injury or loss of life.

E. Install Vent Damper. See Figure 10.

1. Open Vent Damper Carton and remove Installation Instructions. Read Installation Instructions thoroughly before proceeding.

NOTICE

Please refer to the specifications, installation instructions and troubleshooting guide packed in the vent damper carton for complete detailed installation instructions.

2. Vent damper should be same size as draft hood outlet. See Figure 1. Unpack vent damper carefully - **DO NOT FORCE CLOSED!** Forcing vent damper may damage gear train and void warranty.

Vent damper assembly includes pre-wired connection harness with polarized plug for use on all EI control systems.

3. Mount vent damper assembly on draft hood without modification to either. Refer to instructions packed with vent damper for specific instructions. Vent damper position indicator to be visible to users.

CAUTION

Provide adequate clearance for servicing - provide 6" minimum clearance between damper and combustible construction.

CAUTION

Do not use one vent damper to control two heating appliances.

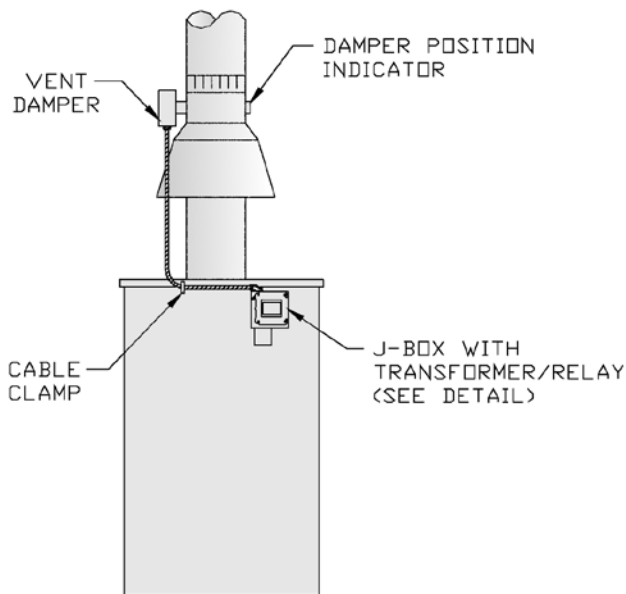

LEFT SIDE VIEW

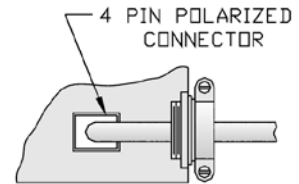

DAMPER WIRING DETAIL

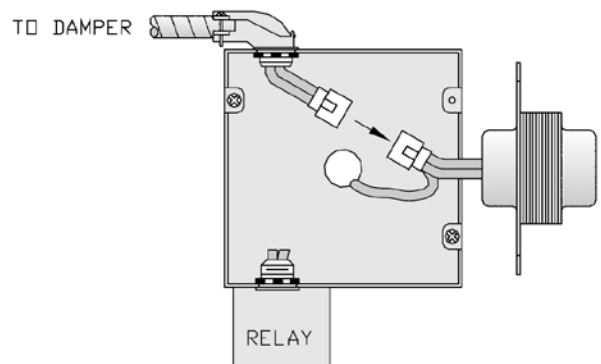

J-BOX CONNECTION DETAIL

Figure 10: Vent Damper Installation

V. Venting (continued)

F. Install Vent Connector from vent damper to chimney or gas vent. See Figure 11.

1. Do not connect into same leg of chimney serving an open fireplace.
2. Vent connector must not be smaller than vent damper outlet. Type B is recommended, but single-wall vent pipe may be used. Arrange venting system so only the boiler is served by vent damper device.
3. Do not connect vent connectors serving appliances vented by natural draft into any portion of mechanical draft system operating under positive pressure.
4. Where two or more appliances vent into a common vent, the area of the common vent should be at least equal to the area of the largest vent plus 50% of the area in the additional vent(s).
5. Vent connector should have greatest possible initial rise above vent damper consistent with headroom available and required clearance from adjacent combustible building structure.
6. Slope horizontal portions of vent pipe upwards not less than 1/4 in/ft from boiler to vent terminal.
7. Support horizontal portions of venting system to prevent sagging. Use pipe straps, brackets or hangers spaced 4 ft. or less.
8. Vent connector should be installed above bottom of chimney to prevent blockage. Inserted into but not beyond inside wall of chimney liner. Seal tight between vent connector and chimney.

G. If an Existing Boiler is Removed:

When an existing boiler is removed from a common venting system, the common venting system is likely to be too large for proper venting of the appliances remaining connected to it.

At the time of removal of an existing boiler, the following steps shall be followed with each appliance remaining connected to the common venting system placed in operation, while the other appliances remaining connected to the common venting system are not in operation:

- a. Seal any unused openings in the common venting system.
- b. Visually inspect the venting system for proper size and horizontal pitch and determine there is no blockage or restriction, leakage, corrosion, and other deficiencies which could cause an unsafe condition.
- c. Insofar as is practical, close all building doors and windows and all doors between the space in which the appliances remaining connected to the common

venting system are located and other spaces of the building. Turn on clothes dryers and any appliance not connected to the common venting system. Turn on any exhaust fans, such as range hoods and bathroom exhausts, so they will operate at maximum speed. Do not operate a summer exhaust fan. Close fireplace dampers.

- d. Place in operation the appliance being inspected. Follow the Lighting Instructions. Adjust thermostat so appliance will operate continuously.
- e. Test for spillage at the draft hood relief opening after 5 minutes of main burner operation. Use the flame of a match or candle, or smoke from a cigarette, cigar or pipe.
- f. After it has been determined that each appliance remaining connected to the common venting system properly vents when tested as outlined above, return doors, windows, exhaust fans, fireplace dampers and any other gas-burning appliance to their previous condition of use.
- g. Any improper operation of the common venting system should be corrected so the installation conforms with the *National Fuel Gas Code*, ANSI Z223.1/NFPA 54. When resizing any portion of the common venting system, the common venting system should be resized to approach the minimum size as determined using the appropriate tables in Chapter 13 of the *National Fuel Gas Code*, ANSI Z223.1/NFPA 54.

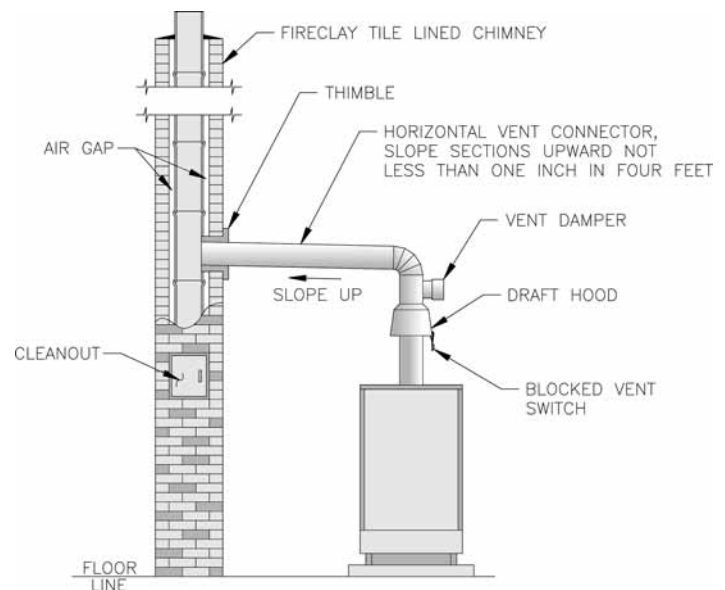

Figure 11: Typical Vent System Installation

VI. Electrical

- A. General.** Install wiring and electrically bond boiler to ground in accordance with requirements of authority having jurisdiction, or in absence of such requirements, the *National Electrical Code*, ANSI/NFPA 70.
- B. Connect Vent Damper.** See Figure 10.
- Carefully remove Transformer from Junction Box.
 - Remove 7/8" knockout from top of Junction Box.
 - Attach Vent Damper wiring harness into top of Junction Box.
 - Connect Vent Damper Wiring Harness to Vent Damper Receptacle.
- C. Wire Low Water Cutoff** (McDonnell & Miller 67 Only). Attach Black wire to Terminal '1'. Attach Black-White wire to Terminal '2'.
- D. Install thermostat.** Locate on inside wall approximately 4 feet above floor. Do not install on outside wall, near fireplace, or where influenced by drafts or restricted air flow, hot or cold water pipes, lighting fixtures, television, or sunlight. Allow free air movement by avoiding placement of furniture near thermostat.
- E. Wire thermostat.** Provide Class II circuit between thermostat and boiler. Connect to Blue transformer lead and Brown relay lead. Set thermostat heat anticipator to 0.4 amps. If system tends to overheat above thermostat's temperature setting, reduce heat anticipator setting by 0.1 or 0.2 amps. If system tends to shortcycle without reaching desired room temperature, increase heat anticipator setting by 0.1 or 0.2 amps.

Table 8: Wiring Diagrams

Low Water Cutoff	Ignition System	Figure No.
	Intermittent (EI)	
24V Probe	X	13
Float	X	14

- F. Wire boiler.** Boiler is rated for 120 VAC, 60 hertz, less than 12 amperes. Provide individual branch circuit with fused disconnect. Connect to black and white wires and green ground screw. Install Transformer on Junction Box.
- G. Vent Damper Sequence of Operation.** See Figure 12.
- Vent Damper continuously powered at Terminal 1.
 - Call for heat energizes Vent Damper through Terminal 5.
 - Vent Damper reaches fully open position. Power is sent back to gas control circuit through Terminal 2.
 - Call for heat ends. Vent Damper closes.
- Note: After Vent Damper is installed and operated through one cycle, the control circuit will operate only when Vent Damper is connected in control circuit.

CAUTION

This boiler contains controls which may cause the boiler to shut down and not restart without service. If damage due to frozen pipes is a possibility, the heating system should not be left unattended in cold weather; or appropriate safeguards and alarms should be installed on the heating system to prevent damage if the boiler is inoperative.

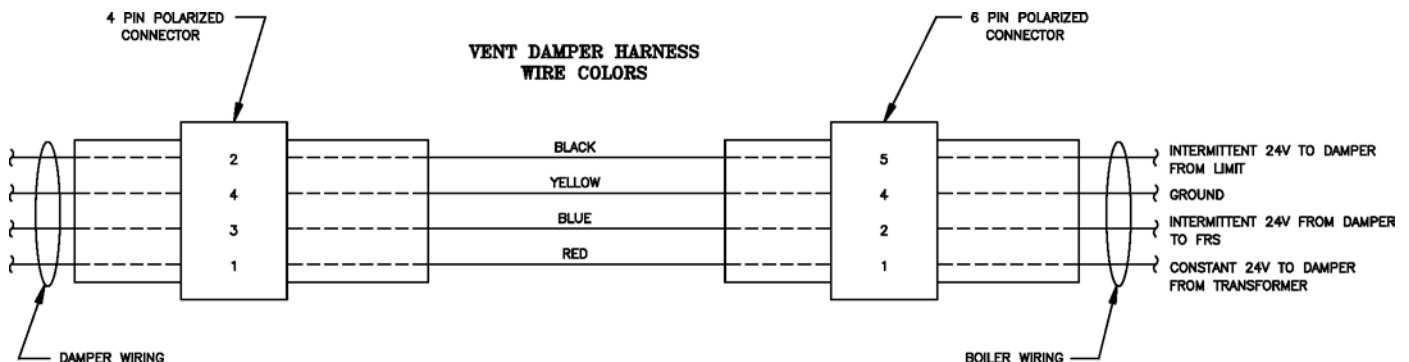

Figure 12: Vent Damper Schematic Wiring Diagram

VI. Electrical (continued)

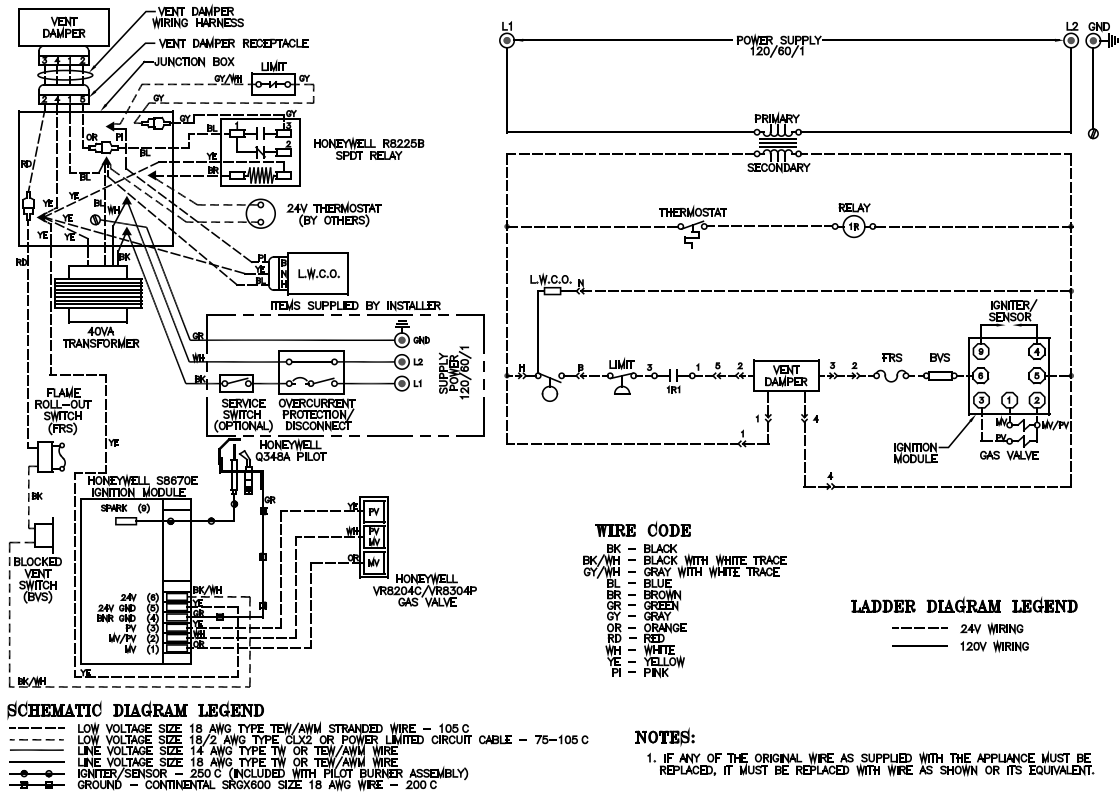

Figure 13: Wiring Diagram, Intermittent Ignition (EI) and Hydrolevel Model 400 or McDonnell & Miller PS-802-24 Low Water Cutoff

I. Sequence of Operation with Intermittent Ignition (EI).

1. Normal Operation

- Thermostat calls for heat. Vent Damper opens. Vent damper must be in open position when appliance main burners are operating.
- Ignition Module energized. Pilot Valve opens. Igniter energized to ignite Pilot Burner.
- Sensor proves presence of pilot flame. Main Valve opens and ignites Main Burners.
- Call for heat ends. Ignition Module is de-energized. Main Valve and Pilot Valve close, extinguishing pilot and main burners. Vent Damper closes.

2. Safety Shutdown

- Low Water Cutoff. Automatically interrupts main burner operation when surface of boiler water falls to lowest permissible operating level. Vent damper closes. Normal operation resumes when water returns to normal level.
- Limit: Automatically interrupts main burner operation when steam pressure exceeds set point. Maximum allowable pressure is 15 psi. Vent Damper closes. Normal operation resumes when steam pressure falls below set point.
- Blocked Vent Switch. Automatically interrupts main burner operation when excessive vent system blockage occurs. Vent Damper remains open with call for heat. If blocked vent switch is activated

do not attempt to place boiler in operation. The source of blockage must be corrected by trained and skilled personnel from a qualified service agency before resetting switch.

- Flame Roll-out Switch. Automatically interrupts boiler operation when flames or excessive heat are present in vestibule. Vent Damper remains open with call for heat. Control is single use device. If flame roll-out switch is activated do not attempt to place boiler in operation. The source of blockage must be corrected and the flame roll-out switch replaced by trained and skilled personnel from a qualified service agency.

- Sensor: senses pilot flame and causes ignition module to turn off main burner and pilot burner gas flow should pilot burner flame extinguish. Ignition module will try to relight pilot for approximately 85 seconds after pilot burner flame is extinguished. If pilot burner flame can not be reestablished, Ignition Module will shutdown.

Five to six minutes after shutdown, Ignition Module automatically restarts ignition sequence. Sequence continues until pilot burner flame is reestablished or call for heat ends. Ignition Module can be manually reset by adjusting thermostat to end call for heat for one minute.

Vent Damper remains open with call for heat.

For Electronic Ignition Troubleshooting Guide, see Figure 21.

VI. Electrical (continued)

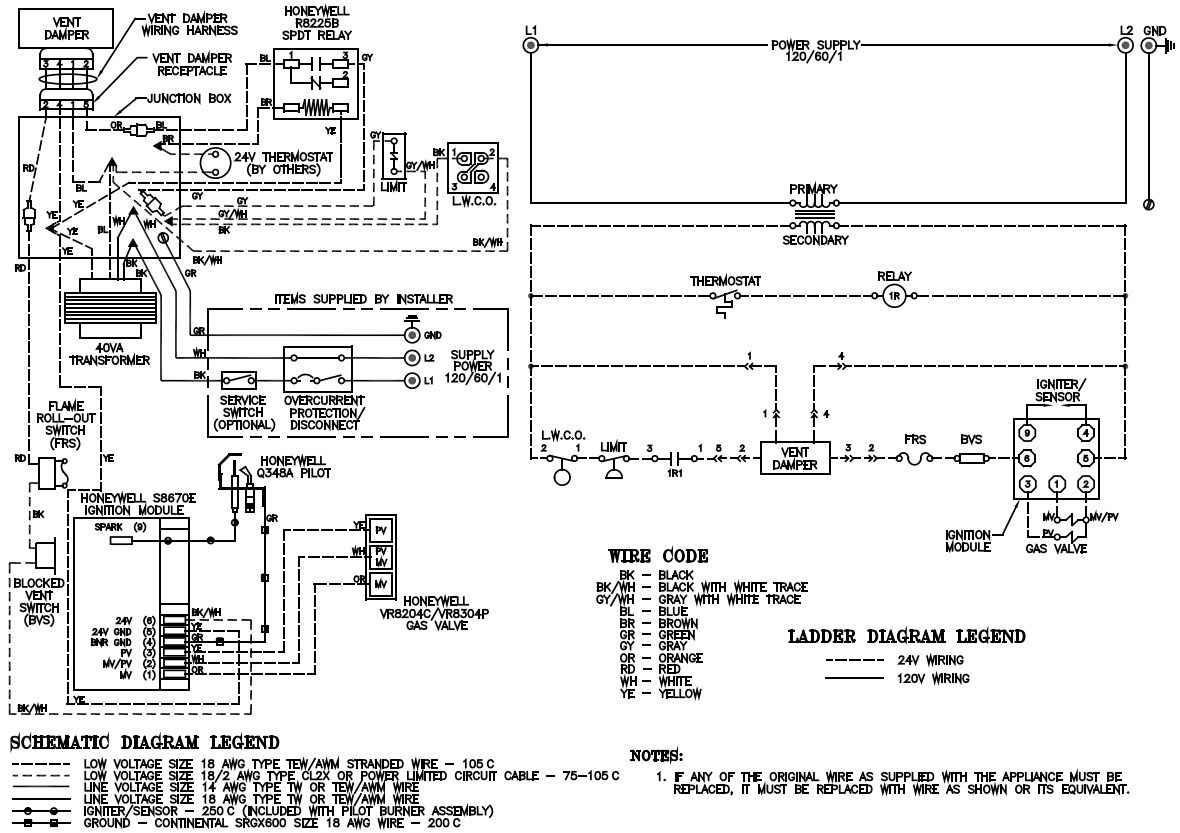

Figure 14: Wiring Diagram, Intermittent Ignition (EI) and McDonnell & Miller 67 Low Water Cutoff

K. Sequence of Operation with Intermittent Ignition (EI).

1. Normal Operation

- a. Thermostat calls for heat. Vent Damper opens. Vent damper must be in open position when appliance main burners are operating.
- b. Ignition Module energized. Pilot Valve opens. Igniter energized to ignite Pilot Burner.
- c. Sensor proves presence of pilot flame. Main Valve opens and ignites Main Burners.
- d. Call for heat ends. Ignition Module is de-energized. Main Valve and Pilot Valve close, extinguishing pilot and main burners. Vent Damper closes.

2. Safety Shutdown

- a. Low Water Cutoff. Automatically interrupts main burner operation when surface of boiler water falls to lowest permissible operating level. Vent damper closes. Normal operation resumes when water returns to normal level.
- b. Limit: Automatically interrupts main burner operation when steam pressure exceeds set point. Maximum allowable pressure is 15 psi. Vent Damper closes. Normal operation resumes when steam pressure falls below set point.
- c. Blocked Vent Switch. Automatically interrupts main burner operation when excessive vent system blockage occurs. Vent Damper remains open with call for heat. If blocked vent switch is activated do

not attempt to place boiler in operation. The source of blockage must be corrected by trained and skilled personnel from a qualified service agency before resetting switch.

- d. Flame Roll-out Switch. Automatically interrupts boiler operation when flames or excessive heat are present in vestibule. Vent Damper remains open with call for heat. Control is single use device. If flame roll-out switch is activated do not attempt to place boiler in operation. The source of blockage must be corrected and the flame rollout switch replaced by trained and skilled personnel from a qualified service agency.

- e. Sensor: senses pilot flame and causes ignition module to turn off main burner and pilot burner gas flow should pilot burner flame extinguish. Ignition module will try to relight pilot for approximately 85 seconds after pilot burner flame is extinguished. If pilot burner flame can not be reestablished, Ignition Module will shutdown.

Five to six minutes after shutdown, Ignition Module automatically restarts ignition sequence. Sequence continues until pilot burner flame is reestablished or call for heat ends. Ignition Module can be manually reset by adjusting thermostat to end call for heat for one minute.

Vent Damper remains open with call for heat.

For Electronic Ignition Troubleshooting Guide, see Figure 21.

VII. System Start-up

- A. Safe operation** and other performance criteria were met with gas manifold and control assembly provided on boiler when boiler underwent tests specified in *American National Standard for Gas-Fired Low-Pressure Steam and Hot Water Boilers, ANSI Z21.13.*
- B. Check main burners.** Rear of burner must be in vertical slot in rear of burner tray. Front of burner must be seated on orifice.
- C. Fill boiler** with water to normal water line.
- D. Prepare to check operation.**
1. Obtain gas heating value (in Btu per cubic foot) from gas supplier.
 2. Adjust limit. Adjust cut-in pressure for 2 psi and differential for 1 psi.
 3. Connect manometer to outlet pressure tap on gas valve.
 4. For natural gas-fired boiler, temporarily turn off all other gas-fired appliances.
- E. Follow Operating Instructions** to place boiler in operation. See Figure 17.
- F. Sequence of Operation** is located under wiring diagram. See Table 8. If boiler fails to operate properly, see Figure 21 for Troubleshooting Guide.
- G. Test gas piping and connections** between Gas Valve and Manifold, orifices, and pilot tubing while boiler is operating. Locate leaks using approved combustible gas detector, soap and water, or similar nonflammable solution. Do not use matches, candles, open flames, or other ignition source.
- H. Check pilot burner flame.** See Figure 15. Pilot produces three (3) flames. Center flame should be steady, medium hard blue enveloping $\frac{3}{8}$ to $\frac{1}{2}$ inch of sensing probe.
- I. Check main burner flame.** See Figure 16. Flame should have clearly defined inner cone with no yellow tipping. Orange-yellow streaks should not be confused with true yellow tipping.
- J. Check thermostat operation.** Raise and lower temperature setting to start and stop boiler operation.
- K. Check ignition system shutoff.** Disconnect Ignition/sensor cable from Terminal 9 (Spark). Gas valve should close and pilot and main burners should extinguish.
- L. Low Water Cutoff.**
1. Adjust thermostat to highest setting.
 2. With boiler operating, open drain valve and slowly drain boiler.

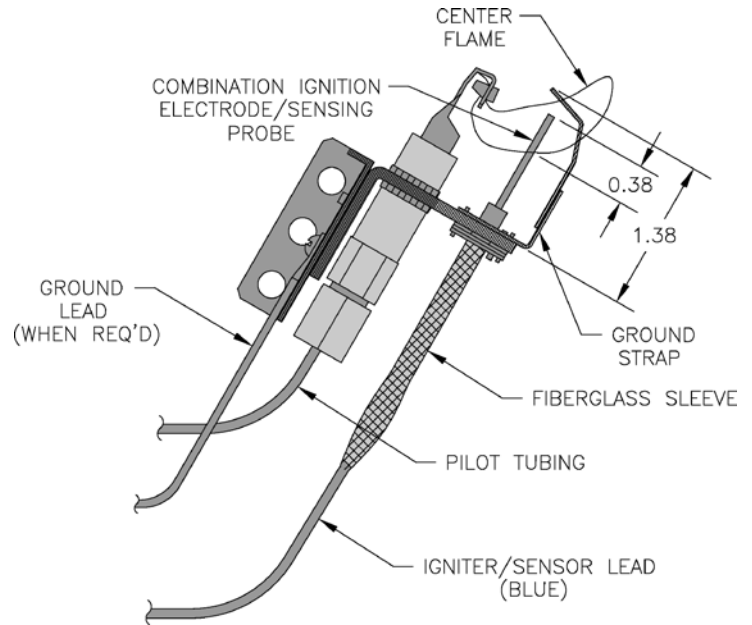

Figure 15: Pilot Burner Flame, Intermittent Ignition

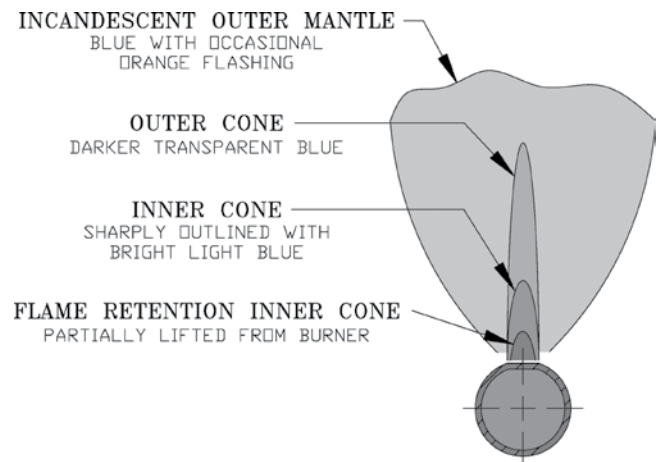

Figure 16: Main Burner Flame

CAUTION

Do not drain below gauge glass.

3. Main burners and pilot burner will extinguish when water level falls below low water cutoff (water should still be visible in gauge glass). Verify limit, thermostat or other controls have not shut off boiler.

CAUTION

Avoid operating this boiler in an environment where saw dust, loose insulation fibers, dry wall dust, etc. are present. If boiler is operated under these conditions, the burner interior and ports must be cleaned and inspected daily to insure proper operation.

VII. System Start-up (continued)

- Adjust thermostat to lowest setting. Refill boiler to normal water line.

M. Check limit.

- Adjust thermostat to highest setting.
- Observe pressure gauge. When pressure is indicated, adjust limit to setting below observed pressure. Main burners should extinguish.
- Adjust limit to setting above observed pressure. Ignition sequence should begin.
- Adjust thermostat to lowest setting. Adjust limit to desired setting.

N. Check Vent Damper Operation.

Vent Damper must be in open position when main burners are ignited.

O. Adjust gas input rate to boiler (Natural Gas).

- Adjust thermostat to highest setting.
- Check manifold gas pressure. Manifold pressure is listed on rating label. Adjust gas valve pressure regulator as necessary (turn adjustment screw counterclockwise to decrease manifold pressure, or clockwise to increase manifold pressure). If pressure can not be attained, check gas valve inlet pressure. If less than minimum gas supply pressure listed on rating label, contact gas supplier for assistance.
- Clock gas meter for at least 30 seconds. Use Table 9 to determine gas flow rate in Cubic Feet per Hour.
- Determine Input Rate. Multiply gas flow rate by gas heating value.
- Compare measured input rate to input rate listed on rating label.
 - Boiler must not be overfired. Reduce input rate by decreasing manifold pressure. Do not reduce more than 0.3 inch w.c. If boiler is still overfired, contact New Yorker Boiler Company for replacement Gas Orifices.
 - Increase input rate if less than 98% of rating label input. Increase manifold gas pressure no more than 0.3 inch w.c. If measured input rate is still less than 98% of rated input:
 - Remove Main Burners per procedure in Section VIII. Service.
 - Remove gas orifices. Drill one (1) drill size larger (drill size is stamped on orifice, or see Section IX. Repair Parts).
 - Reinstall gas orifices and main burners. Measure input rate.
- Recheck Main Burner Flame.
- Follow instructions to TURN OFF GAS TO APPLIANCE. See Figure 17. Remove manometer.

NOTICE

CGS-A boilers built for installation at altitudes greater than 2,000 feet above sea level have been specially orificed to reduce gas input rate 4 percent per 1,000 feet above sea level per the National Fuel Gas Code, ANSI Z223.1/NFPA 54, Section 8.1.2 and Appendix F. High altitude boiler models are identifiable by the third digit in the model number suffix on the rating label:

**CGS_OA__ - __ 2: less than 2000 ft. elevation
CGS_OA__ - __ 5: 2000 to 5000 ft. elevation**

Table 9: Gas Flow Rate in Cubic Feet per Hour

Seconds for One Revolution	Size of Gas Meter Dial			
	One-Half Cu. Ft.	One Cu. Ft.	Two Cu. Ft.	Five Cu. Ft.
30	60	120	240	600
32	56	113	225	563
34	53	106	212	529
36	50	100	200	500
38	47	95	189	474
40	45	90	180	450
42	43	86	172	430
44	41	82	164	410
46	39	78	157	391
48	37	75	150	375
50	36	72	144	360
52	35	69	138	346
54	33	67	133	333
56	32	64	129	321
58	31	62	124	310
60	30	60	120	300
62	29	58	116	290
64	29	56	112	281
66	29	54	109	273
68	28	53	106	265
70	26	51	103	257
72	25	50	100	250
74	24	48	97	243
76	24	47	95	237
78	23	46	92	231
80	22	45	90	225

VII. System Start-up (continued)

FOR YOUR SAFETY READ BEFORE OPERATING

WARNING: If you do not follow these instructions exactly, a fire or explosion may result causing property damage, personal injury, or loss of life.

A. This appliance is equipped with an ignition device which automatically lights the pilot. Do not try to light the pilot by hand.

B. BEFORE OPERATING smell all around the appliance area for gas. Be sure to smell next to the floor because some gas is heavier than air and will settle on the floor.

WHAT TO DO IF YOU SMELL GAS

- ▶ Do not try to light any appliance.
- ▶ Do not touch any electric switch; do not use any phone in your building.
- ▶ Immediately call your gas supplier from a neighbor's phone. Follow the gas supplier's instructions.

▶ If you cannot reach your gas supplier, call the fire department.

C. Use only your hand to push in or turn the gas control knob. Never use tools. If the knob will not push in or turn by hand, don't try to repair it, call a qualified service technician. Force or attempted repair may result in a fire or explosion.

D. Do not use this appliance if any part has been under water. Immediately call a qualified service technician to inspect the appliance and to replace any part of the control system and any gas control which has been under water.

OPERATING INSTRUCTIONS

1. STOP! Read the safety information above on this label.
2. Set the thermostat to lowest setting.
3. Turn off all electric power to the appliance.
4. This appliance is equipped with an ignition device which automatically lights the pilot. Do not try to light the pilot by hand.
5. Locate the gas control valve at the end of the gas supply pipe going into the boiler. The gas control knob is the brown or blue plastic knob located on top of the gas control valve.
6. Rotate gas control knob clockwise from "ON" position to "OFF". Make sure knob rests against stop.
7. Wait five (5) minutes to clear out any gas. Then smell for gas, including near the floor. If you smell gas, STOP! Follow "B" in the safety information above on this label. If you do not smell gas, go to the next step.
8. Rotate gas control knob counterclockwise from "OFF" to "ON". Make sure knob rest against stop. Do not force.
9. Turn on all electric power to the appliance.
10. Set thermostat to desired setting.
11. If the appliance will not operate, follow the instructions "TO TURN OFF GAS TO APPLIANCE" and call your service technician or gas supplier.

GAS INLET

GAS CONTROL KNOB

POSITION INDICATOR

TO TURN OFF GAS TO APPLIANCE

1. Set the thermostat to lowest setting.
2. Turn off all electric power to the appliance if service is to be performed.
3. Rotate gas control knob clockwise from "ON" position to "OFF". Make sure knob rests against stop.

Figure 17: Operating Instructions

8. Follow Operating Instructions to place boiler in operation. See Figure 17. Adjust thermostat to normal setting.
9. Return other gas-fired appliances to previous conditions of use.

P. Adjust gas input rate to boiler (LP/Propane).

1. Adjust thermostat to highest setting.
2. Check manifold pressure. Adjust gas valve pressure regulator to obtain 10 inches w.c. manifold pressure. Adjust gas valve pressure regulator as necessary (turn adjustment screw counterclockwise to decrease manifold pressure, or clockwise to increase manifold pressure). If pressure can not be attained, check gas valve inlet pressure. If less than minimum gas supply pressure listed on rating label, contact gas supplier for assistance.

3. Recheck Main Burner Flame
4. Follow instructions to TURN OFF GAS TO APPLIANCE. See Figure 17. Remove manometer.
5. Follow Operating Instructions to place boiler in operation. See Figure 17. Adjust thermostat to normal setting.

Q. Clean Heating System. Oil from new piping connections and sediment in existing piping must be removed from the system to prevent unsteady water line and carry-over of entrained water into supply main.

1. Fill boiler to normal waterline.
2. Follow Operating Instructions to place boiler in operation. See Figure 17.
3. Operate the boiler with steam in the entire system for several days to bring system oil and dirt back to the boiler.

VII. System Start-up (continued)

4. Drain condensate from drain valve in wet return. Operate boiler until condensate runs clean.

R. Boil-out boiler.

1. Follow instructions TO TURN OFF GAS TO APPLIANCE. See Figure 17.
2. Drain boiler until 1" of water is visible in gauge glass.
3. Run temporary hose or piping from boiler drain valve to an open drain or some other location where hot water may be discharged safely. Do not install valve in this line.
4. Drain about 5 gallons of hot water from boiler into a container and dissolve into it an appropriate amount of recommended boil out compound. Remove safety valve and add solution to boiler water through exposed tapping using a funnel.

NOTICE

Check with local authorities or consult local water treatment services for acceptable chemical cleaning compounds.

5. Run temporary hose or piping from boiler tapping "E" to an open drain or some other location where hot water may be discharged safely. Do not install valve in this line (See Figure 4).
6. Follow Operating Instructions to place boiler in operation. See Figure 17.
7. Operate sufficiently to boil the water without producing steam pressure. Boil for about 5 hours. Open boiler fill valve sufficiently to permit a steady trickle of water from the pipe. Continue this slow boiling and trickle of overflow for several hours until the water coming from the overflow is clear.
8. Follow instructions TO TURN OFF GAS TO APPLIANCE. See Figure 17.
9. Drain boiler in a manner and to a location that hot water can be discharged with safety.
10. Refill boiler to normal water line. If water in gauge glass does not appear to be clear, repeat steps (1 thru 3) and boil out the boiler for a longer time.

S. Second Boilout for Stubborn Cases. If unsteady water line, foaming or priming persist, proceed as follows:

1. Connect hoses from boiler and return main drain valves to floor drain. Close shut off valve in Hartford Loop and open drain valve in return main. Fill boiler to normal water level.
2. Follow Operating Instructions to place boiler in operation. See Figure 17.

3. Operate boiler at this water level for at least 30 minutes after the condensate begins to run hot.
4. Follow instructions TO TURN OFF GAS TO APPLIANCE. See Figure 17.
5. Close all radiator valves. Remove all supply main air valves and plug the openings in supply main.
6. Draw about 5 gallons of hot water from boiler into a container and dissolve into it the appropriate amount of a recommended boilout compound. Remove safety valve from boiler and pour this solution into boiler, then reinstall safety valve.
7. Follow Operating Instructions to place boiler in operation. See Figure 17.
8. Keep operating boiler while feeding water to boiler slowly. This will raise water level in boiler slowly so that water will be boiling hot and will rise slowly into supply main and back through return main, flowing from drain hose at about 180°F. Continue until water runs clear from drain hose for at least 30 minutes.
9. Stop feeding water to boiler but continue operating boiler until excess water in boiler flows out through supply main and water lowers (by steaming) until it reaches normal level in boiler.
10. Follow instructions to TURN OFF GAS TO APPLIANCE. See Figure 17.
11. Drain boiler. Open all radiator valves. Reinstall all supply main air valves. Open shut off valve in Hartford Loop.
12. When boiler has cooled down sufficiently (iron sections are not too hot to touch), close the drain valves at boiler and in return main and feed water slowly up to normal level in boiler.
13. Follow Operating Instructions to place boiler in operation. See Figure 17.
14. Allow boiler to steam for 10 minutes.
15. Follow instructions to TURN OFF GAS TO APPLIANCE. See Figure 17.
16. Draw off one quart of water from bottom gauge glass fitting and discard. Draw off another quart sample and if this sample is not clear, repeat the cycle of draining the boiler and return main and refilling the boiler until sample is clear.

If the boiler water becomes dirty again at a later date due to additional sediment loosened up in the piping:

1. Follow instruction to TURN OFF GAS TO APPLIANCE. See Figure 17.
2. Close shut off valve in Hartford Loop and open drain valve in return main.

VII. System Start-up (continued)

3. Follow Operating Instructions to place boiler in operation. See Figure 17.
4. Allow condensate to flow to drain until it has run clear for at least 30 minutes while feeding water to boiler so as to maintain normal water level.
5. Follow instructions to TURN OFF GAS TO APPLIANCE. See Figure 17.
6. Drain boiler, open shut off valve in Hartford Loop, then repeat step R. above.

T. Add Boiler Water Treatment.

1. Low pressure steam boilers such as this CGS-A Series should be maintained with appropriate water treatment compounds. Add suitable water treatment compounds as recommended by your qualified water treatment company.
2. Remove temporary drain valve and overflow piping and reinstall safety valve. Boil or bring water temperature to 180°F promptly in order to drive off the dissolved gases in the fresh water.
3. Make pH or Alkalinity Test.

After boiler and system have been cleaned and refilled as previously described, test the pH of the water in the system. This can easily be done by drawing a small sample of boiler water and testing with hydrion dispenser gives the reading in pH. Hydrion paper is inexpensive and obtainable from any chemical supply house or through your local druggist. The pH should be higher than 7, but lower than 11. Add some of the washout chemical, if necessary, to bring the pH within the specified range.

4. Boiler is now ready to be put into service.

U. Combustion Chamber Burn-off

1. The mineral wool combustion chamber panels contain a cornstarch based binder that must be burned out a installation to prevent odors during subsequent boiler operation.
2. Ventilate the boiler room, set the high limit to its maximum setting, set the thermostat to call for heat. Allow the boiler to fire for at least an hour or until the odor from the cornstarch has dissipated.
3. Return the high limit and thermostat to their desired settings.

V. Review User's Information Manual and system operation with owner or operator.

W. Post instructions near boiler for reference by owner and service personnel. Maintain instructions in legible condition.

Important Product Safety Information **Refractory Ceramic Fiber Product**

Warning:

The Repair Parts list designates parts that contain refractory ceramic fibers (RCF). RCF has been classified as a possible human carcinogen. When exposed to temperatures about 1805°F, such as during direct flame contact, RCF changes into crystalline silica, a known carcinogen. When disturbed as a result of servicing or repair, these substances become airborne and, if inhaled, may be hazardous to your health.

AVOID Breathing Fiber Particulates and Dust

Precautionary Measures:

Do not remove or replace RCF parts or attempt any service or repair work involving RCF without wearing the following protective gear:

1. A National Institute for Occupational Safety and Health (NIOSH) approved respirator
 2. Long sleeved, loose fitting clothing
 3. Gloves
 4. Eye Protection
- Take steps to assure adequate ventilation.
 - Wash all exposed body areas gently with soap and water after contact.
 - Wash work clothes separately from other laundry and rinse washing machine after use to avoid contaminating other clothes.
 - Discard used RCF components by sealing in an airtight plastic bag. RCF and crystalline silica are not classified as hazardous wastes in the United States and Canada.

First Aid Procedures:

- If contact with eyes: Flush with water for at least 15 minutes. Seek immediate medical attention if irritation persists.
- If contact with skin: Wash affected area gently with soap and water. Seek immediate medical attention if irritation persists.
- If breathing difficulty develops: Leave the area and move to a location with clean fresh air. Seek immediate medical attention if breathing difficulties persist.
- Ingestion: Do not induce vomiting. Drink plenty of water. Seek immediate medical attention.

VIII. Service (continued)

WARNING

Service on this boiler should be undertaken only by trained and skilled personnel from a qualified service agency. Inspections should be performed at intervals specified in this manual. Maintain manual in a legible condition.

Keep boiler area clear and free of combustible materials, gasoline and other flammable vapors and liquids.

Do not place any obstructions in boiler room that will hinder flow of combustion and ventilation air.

A. General. Inspection and service should be conducted annually, except as noted. Turn off electrical power and gas supply while conducting service or maintenance. Follow instructions TO TURN OFF GAS TO APPLIANCE. See Figure 17.

CAUTION

Label all wires prior to disconnection when servicing controls. Wiring errors can cause improper and dangerous operation. Verify proper operation after servicing.

B. Flame Current Measurement Procedure.

See Figure 18 “Measuring pilot flame current with micro-ammeter”.

Table 10 cross-references the ignition module terminal designations to the ignition terminal numbers in the wiring ladder diagrams. Table 11 provides green LED status codes and recommended service action where applicable.

1. Pilot flame current in micro amps can be measured using any standard micro-ammeter by inserting the meter probes into the module holes labeled FLAME CURRENT as shown in Figure 18.
2. Flame current **must be measured with pilot valve open/pilot lit but the main valve closed.**
3. Disconnect MV lead wire from the module before measuring flame current. Trying to measure the pilot flame current in series with the wiring will not yield the accurate reading.
4. The **minimum steady pilot flame signal must be 1 μ Amp** (microampere) DC (direct current).

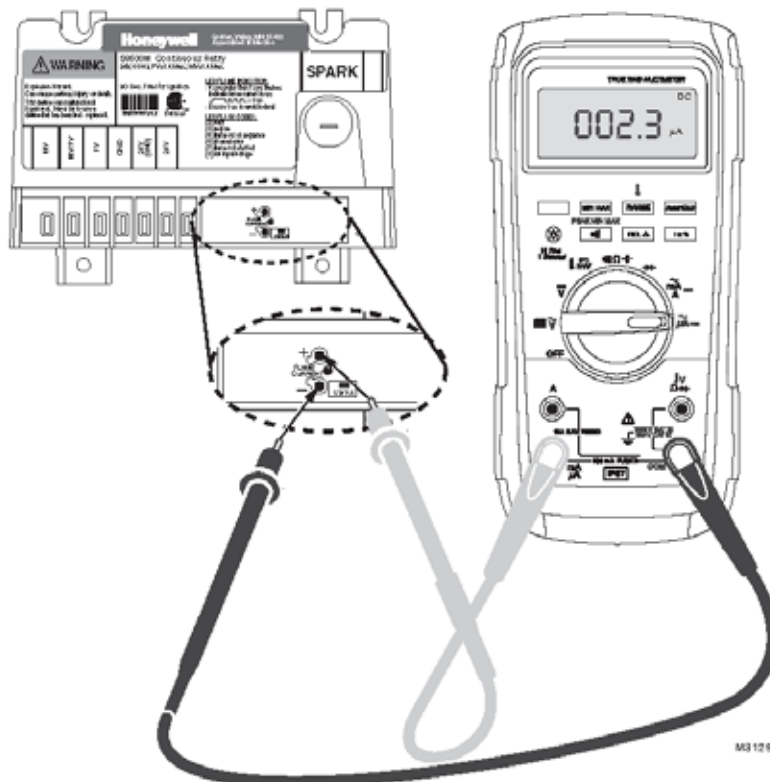

Figure 18: Measuring Pilot Flame Current with Micro-ammeter

VIII. Service (continued)

Table 10: Ignition Module Terminal Cross-Reference

Ignition Module Terminal Designation	Wiring Ladder Diagram Terminal Number
MV	1
MV/PV	2
PV	3
GND	4
24V (GND)	5
24V	6
SPARK	9

Table 11: Green LED Status Codes

Green LED Flash Code ^a	Indicates	Next System Action	Recommended Service Action
OFF	No "Call for Heat"	N/A	None
Flash Fast	Power up - internal check	N/A	None
Heartbeat	Normal startup - ignition sequence started (including prepurge)	N/A	None
4 Seconds ON then "x" flashes	Device in run mode. "x" = flame current to the nearest μ A.	N/A	None
2	5 minute Retry Delay - Pilot flame not detected during trial for ignition	Initiate new trial for ignition after retry delay completed.	If system fails to light on next trial for ignition check gas supply, pilot burner, spark and flame sense wiring, flame rod contamination or out of position, burner ground connection.
3	Recycle - Flame failed during run	Initiate new trial for ignition. Flash code will remain through the ignition trial until flame is proved.	If system fails to light on next trial for ignition, check gas supply, pilot burner, flame sense wiring, contamination of flame rod, burner ground connection.
4	Flame sensed out of sequence	If situation self corrects within 10 seconds, control returns to normal sequence. If flame out of sequence remains longer than 10 seconds, control will resume normal operation 1 hour after error is corrected.	Check for pilot flame. Replace gas valve if pilot flame present. If no pilot flame, cycle "Call for Heat." If error repeats, replace control.
6	Control Internal Error	Control remains in wait mode. When the fault corrects, control resumes normal operation.	Cycle "Call for Heat". If error repeats, replace control.
7	Flame rod shorted to ground	Control remains in wait mode. When the fault corrects, control resumes normal operation.	Check flame sense lead wire for damage or shorting. Check that flame rod is in proper position. Check flame rod ceramic for cracks, damage or tracking.
8	Low secondary voltage supply- (below 15.5 Vac)	Control remains in wait mode. When the fault corrects, control resumes normal operation.	Check transformer and AC line for proper input voltage to the control. Check with full system load on the transformer.

^aFlash Code Descriptions:

- Flash Fast: rapid blinking
- Heartbeat: Constant 1/2 second bright, 1/2 second dim cycles.
- 4 second solid on pulse followed by "x" 1 second flashes indicates flame current to the nearest μ A. This is only available in run mode.
- A single flash code number signifies that the LED flashes X times at 2Hz, remains off for two seconds, and then repeats the sequence.

5. **For reliable operation** the flame current should be **2 μ Amp or greater.**
6. To ensure **adequate flame current:**
 - a. Turn off boiler power at circuit breaker or fuse box.
 - b. Clean the flame rod with emery cloth if required
 - c. Make sure electrical connections are clean and tight, and wiring not damaged, repair/replace as needed.
 - d. Check for igniter/sensor cracked ceramic insulator, replace if needed.
 - e. Check the pilot flame. It must be blue, steady and envelop the flame sensing rod 3/8" to 1/2".

VIII. Service (continued)

- f. If needed, adjust pilot flame by turning the gas valve pilot adjustment screw clockwise to decrease or counterclockwise to increase pilot flame. Always reinstall pilot adjustment screw cover and tighten securely upon completion to assure proper gas valve operation.
7. Reconnect MV lead wire to the module upon satisfactory completion of pilot flame current measurement.
8. Check the pilot burner operation/ignition sequence during ignition cycle:
 - a. Restore boiler power at circuit breaker or fuse box.
 - b. Set thermostat to call for heat.
 - c. Watch ignition sequence at burner.
 - d. If spark does not stop after pilot lights, replace ignition module.
 - e. If main burners do not light or if main burners light but system locks out, check the module ground wire and gas control as described in Figure 21 “Honeywell Electronic Ignition Troubleshooting Guide”.

C. 24 Volt Probe Low Water Cutoff. Hydrolevel Model 400 and McDonnell & Miller PS-802-24 Only.

1. Drain boiler to point below Tapping 'K'.
2. Disconnect wire(s) connecting control and probe.
3. Remove control from probe.
4. Unscrew probe from Tapping 'K'. Inspect for scale and sediment buildup.
5. Remove light deposits with damp cloth soaked with vinegar.
6. Remove stubborn deposits using diluted phosphoric acid (H_2PO_4) solution, 3 parts water to 1 part phosphoric acid. Normal operation will occur with up to 0.2 inch of contamination. If scale or contamination exceeds 0.2 inches clean probe more frequently.
7. Clean Tapping 'K' to remove old pipe dope and other foreign matter.
8. Apply moderate amount of good quality pipe dope to probe threads, leaving two end threads bare. Install probe in Tapping 'K'. Mount control on probe. Attach wire(s) between control and probe.
9. Fill boiler to normal waterline. Add water treatment as needed.

D. Float Low Water Cutoff. McDonnell & Miller 67 Only.

1. Weekly (or more frequently if necessary). Open blow-off valve to flush sediment chamber. Follow instructions on Blow-Down Card affixed to Jacket adjacent to low water cutoff.
2. Annual. Dismantle to extent necessary to remove obstructions and insure proper function of working parts.
 - a. Inspect connecting lines to boiler for accumulation of mud and scale. Clean as necessary.
 - b. Examine wiring for brittle or worn insulation and clean electrical contact.
 - c. Inspect solder joints on bellows and float. Check float for evidence of collapse. Check mercury bulb (where applicable) for mercury separation or discoloration. *Do not attempt to repair mechanisms in field.* Complete replacement mechanisms, including gaskets and instructions, are available from low water cutoff manufacturer.
3. Five (5) Years or 100,000 switch cycles. Replace switch and float mechanisms.

E. Water Feeder and Additional Low Water Cut-Off. Refer to manufacturer's instructions.

F. Inspect Vent System. See Figure 11.

1. Remove obstructions in vent pipe and chimney.
2. Remove soot accumulations with wire brush and vacuum.
3. Repair or replace deteriorated vent pipe and vent accessories.
4. Provide proper support. Repair sags, particularly in horizontal sections.
5. Repair leaking joints.

G. Inspect Boiler Flue Passages for blockage or soot accumulation. See Figures 19 and 20.

1. Remove Jacket Vestibule Panel.
2. Remove Draffhood.
3. Inspect flueways for blockage or soot accumulation through flue outlet of canopy.
4. If cleaning is required, remove canopy from cast iron heat exchanger. Boiler cement should be scraped from canopy and heat exchanger.
5. Thoroughly clean flueways with flue brush.
6. Clean heating surface accessible from combustion chamber using straight handle wire brush.

VIII. Service (continued)

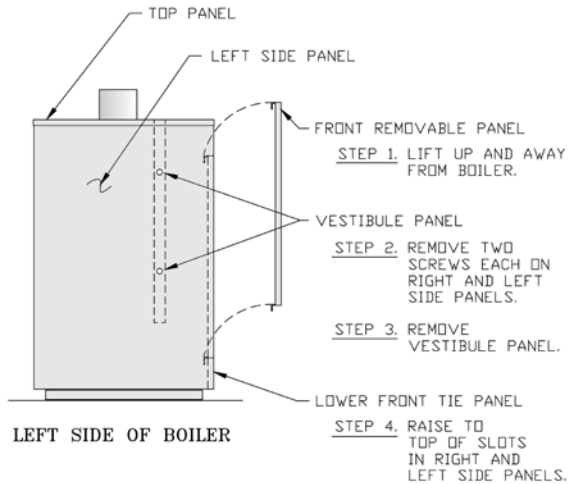

Figure 19: Jacket Front Panel and Vestibule Panel Removal

7. Install canopy
 - a. Verify that sealing surfaces between canopy and heat exchanger are clean.
 - b. Secure canopy to heat exchanger with carriage bolts, nuts, and washers.
 - c. Seal gap between canopy and heat exchanger with high temperature boiler cement or Dow Corning Silastic 732 RTV, Dow Corning Silastic 736 RTV, Polybac #500 RTV, or Sil-bond RTV 4500 (Acetoxy). Do not use other adhesives or sealants.
8. Install Main Burners per Paragraph H. Install Jacket Vestibule Panel.

H. Clean Main Burners and Firebox.

1. To remove burners for cleaning, changing orifices, or repairs:
 - a. Disconnect pilot tubing at the gas valve.
 - b. Disconnect igniter cable, sensor cable and ground wire at Ignition Module.
 - c. Disconnect Flame Rollout Switch wires.
 - d. Remove Burner Access Panel.
 - e. Lift front of burner to clear orifice and lift burner out. Burner which holds pilot can only be removed by lifting at a 45° angle after burner adjacent to its right is removed.
2. Brush top of burners with a soft bristle brush. See Figure 20. Vacuum burners.
3. Check orifices. Drilled passageways must be free of lint or dirt.
4. Vacuum tip of Pilot Burner.

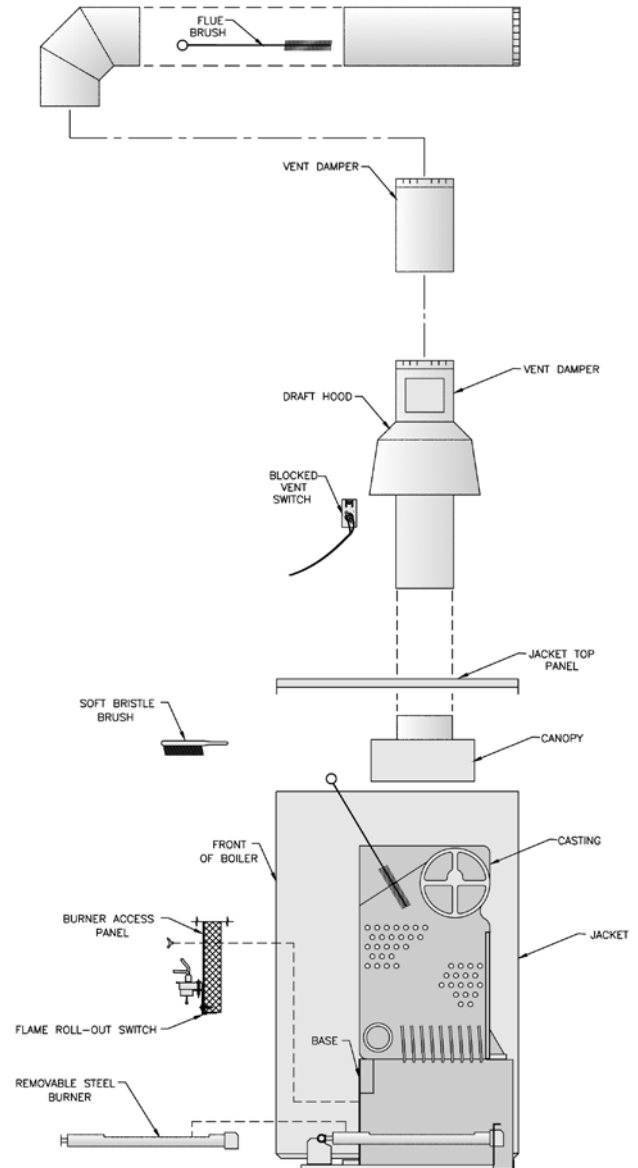

Figure 20: Flueway Cleaning

5. Clean firebox by vacuuming. Exercise care not to damage base insulation.
6. Install burners by reversing procedure used to remove burners. Burner with pilot assembly must be in same location as original installation. See Table 12. Burners must be properly located on support bracket at rear of burner. Front of burner must be seated on orifice and secured with hitch pin clips.
7. Reconnect pilot tubing at the gas valve.
8. Connect igniter/sensor cable, and ground wire at Ignition Module.
9. Install Burner Access Panel. Connect Flame Rollout Switch wires.

VIII. Service (continued)

Table 12: Pilot Burner Location

Boiler Model	Main Burner with Pilot Bracket *	Pilot Burner Located Between Main Burners *
CGS30A	2	2 & 3
CGS40A	2	2 & 3
CGS50A	4	4 & 5
CGS60A	6	6 & 7
CGS70A	7	7 & 8
CGS80A	9	9 & 10

* Main burners numbered left to right as viewed from front of boiler.

- I. Check operation.** Follow steps D through P from Section VII: System Start-up.
- J. Lubrication.** There are no parts requiring lubrication by service technician or owner.

VIII. Service (continued)

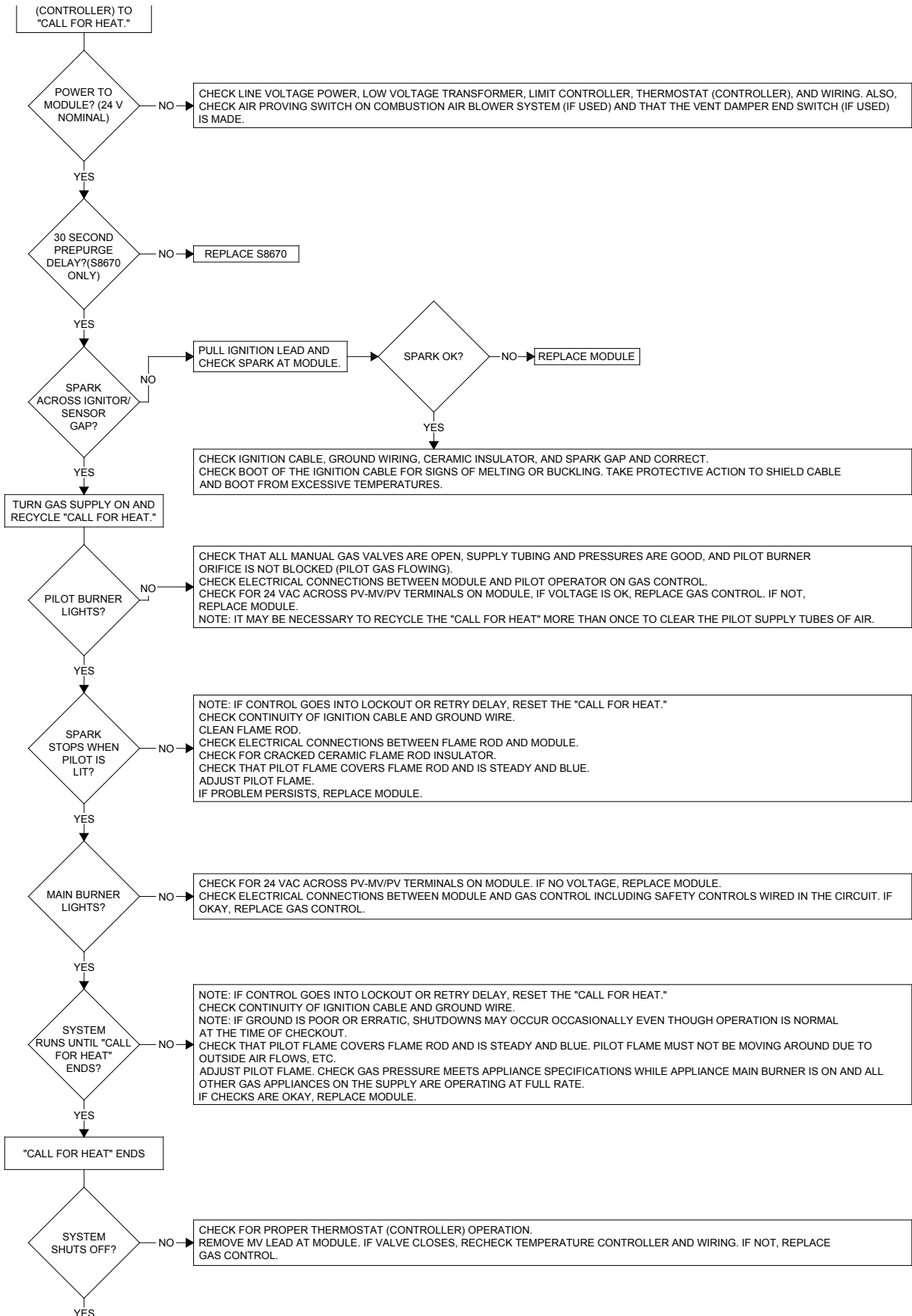

Figure 21: Honeywell Electronic Ignition Troubleshooting Guide

IX. Repair Parts

All CGS-A™ Series repair parts may be obtained through your local New Yorker Boiler Co., Inc. authorized distributor. Should you require assistance in locating a New Yorker distributor in your area, or have questions regarding the availability of New Yorker products or repair parts, please contact New Yorker's main office:

New Yorker Boiler Co., Inc.
P.O. Box 10
Hatfield, PA 19440-0010
Phone: (215) 855-8055
Attn: Customer Service Department

Description	Part No.	Quantity					
		30	40	50	60	70	80
Cast Iron Section Assembly (Complete)	61760301	1	---	---	---	---	---
	61760401	---	1	---	---	---	---
	61760501	---	---	1	---	---	---
	61760601	---	---	---	1	---	---
	61760701	---	---	---	---	1	---
	61760801	---	---	---	---	---	1
Canopy	6111203	1	---	---	---	---	---
	6111204	---	1	---	---	---	---
	6111205	---	---	1	---	---	---
	6111206	---	---	---	1	---	---
	6111207	---	---	---	---	1	---
	6111208	---	---	---	---	---	1
Cerafelt Sealing Strip 1/2" x 2" x 88" (Section Assembly to Base)	72017071	1	1	1	1	1	1
Main Burner w/Slotted Orifice Bracket	8236119	3	4	6	9	11	14
Main Burner with 60° Pilot Bracket - Intermittent Ignition (EI) Only	8236118	1	1	1	1	1	1
Manifold	82260035	1	---	---	---	---	---
	82260045	---	1	---	---	---	---
	82260055	---	---	1	---	---	---
	82260065	---	---	---	1	---	---
	82260075	---	---	---	---	1	---
	82260085	---	---	---	---	---	1

IX. Repair Parts (continued)

Description	Part No.	Quantity					
		30	40	50	60	70	80
Main Burner Orifice, #45 (Pink) (Natural Gas)	822711	---	5	7	---	---	---
Main Burner Orifice, #48 (Natural Gas)	822726	4	---	---	10	12	---
Main Burner Orifice, #49 (Yellow) (Natural Gas)	822709	---	---	---	---	---	15
Main Burner Orifice, 1.25 mm (Purple) (LP)	822705	---	---	7	---	---	---
Main Burner Orifice, #55 (Green) (LP)	822708	---	5	---	---	---	---
Main Burner Orifice, #56 (LP)	822707	---	---	---	---	---	15
Main Burner Orifice, 3/64" (Blue) (LP)	822704	4	---	---	10	12	---
Pilot Tubing, 1/4" OD x 30" Lg. Aluminum	8236122	1	1	1	---	---	---
Pilot Tubing, 1/4" OD x 40" Lg. Aluminum	8236123	---	---	---	1	1	1
Intermittent Ignition (EI)							
Pilot Burner, Honeywell Q3481B1206 (Natural Gas)	103704-01	1	1	1	1	1	1
Pilot Burner, Honeywell Q3481B1420 (LP/Propane)	103705-01						
Ground Wire Assembly, 36" Lg.	6136054	1	1	1	1	1	1
Gas Valve, Honeywell VR8204C6000 (Natural Gas)	81660145	1	1	1	1	---	---
Gas Valve, Honeywell VR8304P4298 (Natural Gas)	81660161	---	---	---	---	1	1
Gas Valve, Honeywell VR8204C6018 (LP/Propane)	81660146	1	1	1	1	---	---
Gas Valve, Honeywell VR8304P4280 (LP/Propane)	81660160	---	---	---	---	1	1
Ignition Module, Honeywell S8610M	100958-01	1	1	1	1	1	1

IX. Repair Parts (continued)

Description	Part No.	Quantity					
		30	40	50	60	70	80
Safety Valve, 15 psi, 3/4 NPT, Conbraco 13-511-08	81660530	1	1	1	1	1	1
Gauge Glass Set, Conbraco 20-104-10 (with 9" Gauge Glass)	8056020	1	1	1	1	1	1
Limit, Honeywell PA404A1009	80160300	1	1	1	1	1	1
Syphon	806603006	1	1	1	1	1	1
Pressure Gauge	100325-01	1	1	1	1	1	1
Drain Valve, Conbraco 35-302-03	806603061	1	1	1	1	1	1
Transformer, 40VA, Honeywell AT140D1012 or Honeywell AT72D1188	80160039	1	1	1	1	1	1
R8225B Relay Assembly	61319040	1	1	1	1	1	1
Transformer-Junction Box Adapter Plate	70110011	1	1	1	1	1	1
Flame Rollout Switch	80160044	1	1	1	1	1	1
Blocked Vent Switch Replacement Assembly	6016066	1	1	1	1	1	1
Low Water Cutoff, Hydrolevel 45-400 (Probe and Control)	80160625	1	1	1	1	1	1
Low Water Cutoff, McDonnell & Miller PS-802 (Probe and Control)	80160720	1	1	1	1	1	1
Low Water Cutoff, McDonnell & Miller 67	80160517	1	1	1	1	1	1
Draft Hood (Natural Gas)	8111928	1	---	---	---	---	---
	8111919	---	1	---	---	---	---
	8111920	---	---	1	---	---	---
	8111922	---	---	---	1	---	---
	8111924	---	---	---	---	1	---
	8111926	---	---	---	---	---	1
Draft Hood (LP/Propane)	8111928	1	---	---	---	---	---
	8111919	---	1	---	---	---	---
	8111921	---	---	1	---	---	---
	8111923	---	---	---	1	---	---
	8111925	---	---	---	---	1	---
	8111927	---	---	---	---	---	1
Vent Damper							
Effikal RVGP-4"	8116321	1	---	---	---	---	---
Effikal RVGP-5"	8116322	---	1	---	---	---	---
Effikal RVGP-6"	8116323	---	---	1	1	---	---
Effikal RVGP-7"	8116324	---	---	---	---	1	1

NEW YORKER BOILER CO., INC.

Limited Warranties

For Residential Cast Iron and Steel Boilers

By this Warranty Statement New Yorker Boiler Co., Inc. ("New Yorker"), issues limited warranties subject to the terms and conditions stated below. These limited warranties apply to residential cast iron and steel water boilers labeled with the New Yorker® brand which are sold on or after March 1, 2004.

ONE YEAR LIMITED WARRANTY

One Year Limited Warranty for Residential Water Boilers New Yorker warrants to the original consumer purchaser at the original installation address that its residential cast iron and steel water boilers will be free from defects in material and workmanship under normal usage for a period of one year from the date of original installation. In the event that any defect in material or workmanship is found during the one year period following the date of installation, New Yorker will, at its option, repair the defective part or provide a replacement free of charge, F.O.B. its factory.

WC BOILER FIVE YEAR LIMITED WARRANTY

Five Year Pressure Vessel Limited Warranty for WC™ Residential Water Boilers New Yorker warrants to the original consumer purchaser at the original installation address that the pressure vessel of the boiler will be free of defects in material and workmanship under normal usage for a period of five years following the date of installation. In the event that any defect in material or workmanship is found during the five year period following the date of installation, New Yorker will, at its option, repair the defective pressure vessel or provide a replacement free of charge, F.O.B. its factory.

LIFETIME LIMITED WARRANTY

For all gas/oil-fired residential boilers, New Yorker warrants to the original consumer purchaser at the original installation address that the heat exchanger of the boiler will be free of defects in material and workmanship under normal usage for the lifetime of the original consumer purchaser. In the event that any defect in material or workmanship is found during the ten year period following the date of installation, New Yorker will, at its option, repair the defective pressure vessel or provide a replacement free of charge, F.O.B. its factory. In the event that any defect in material or workmanship is found after the tenth year following the date of installation, New Yorker will provide a replacement pressure vessel upon payment by the original consumer purchaser of an amount equal to a percentage of the then current retail price of the model boiler involved (or, in the event that such model is not then in production, the most comparable model then in production), as follows:

		Service Charge as a % of Retail Price																			
Years in Service	1-5	6	7	8	9	10	11	12	13	14	15	16	17	18	19	20	21	22	23	24	25+
WC Boilers	N/C	100																			
Water Boilers	No Charge	5	10	15	20	25	30	35	40	45	50	55	60	65	70	75					
Steam Boilers	No Charge	100																			

EXCEPTIONS AND EXCLUSIONS

- Components Manufactured by Others** - following the expiration of the foregoing one year limited warranty, all component parts of a boiler which are manufactured by others (such as burners, burner controls, circulator, tankless water heater, and New Yorker Link) shall be subject only to the manufacturer's warranty, if any.
- Removal and Replacement Costs** - these warranties do not cover expenses of removal or reinstallation. The consumer purchaser will be responsible for the cost of removing and replacing any defective part and all labor and related materials connected therewith. Replacement parts will be invoiced to the distributor in the usual manner and will be subject to adjustment upon proof of defect.
- Proper Installation** - these warranties are conditioned upon the installation of the boiler in strict compliance with New Yorker's Installation, Operating and Service Instructions. New Yorker specifically disclaims any liability of any kind which arises from or relates to improper installation.
- Improper Use or Maintenance** - these warranties will not be applicable if the boiler is used or operated over its rated capacity, is installed for uses other than home heating, or is not maintained in accordance with New Yorker's Installation, Operating and Service Instructions and hydronics industry standards.
- Improper Operation** - these warranties will not be applicable if the boiler has been damaged as a result of being improperly serviced or operated, including but not limited to the following:

operated with insufficient water; allowed to freeze; subjected to flood conditions; or operated with water conditions and/or fuels or additives which cause unusual deposits or corrosion or on the pressure vessel or associated controls.

- Geographic Limitations** - these warranties apply only to boilers installed within the 48 contiguous United States.
- Installation Requirements** - in order for these warranties to be effective:
 - The boiler must be installed in a single or two-family residential dwelling. This warranty does not apply to boilers installed in apartments for commercial or industrial applications.
 - The boiler must be installed in strict compliance with New Yorker's Installation, Operating and Service Instructions by an installer regularly engaged in boiler installations.
 - Boiler sections must not have been damaged during shipment or installation.
 - The boiler must be vented in accordance with chimney recommendations set forth in New Yorker's Installation, Operating and Service Instructions.
- Exclusive Remedy** - New Yorker's obligation in the event of any breach of these warranties is expressly limited to the repair or replacement of any part found to be defective under conditions of normal use.
- Limitation of Damages Under no circumstances will New Yorker be liable for incidental, indirect, special or consequential damages of any kind under these warranties, including, without limitation, injury or damage to persons or property and damages for loss of use, inconvenience or loss of time.** New Yorker's liability under these warranties shall under no circumstances exceed the purchase price paid for the boiler involved. Some states do not allow the exclusion or limitation of incidental or consequential damages, so the above limitation or exclusion may not apply to you.
- Limitation of Warranty** - these limited warranties are given in lieu of all other express warranties and set forth the entire obligation of New Yorker with respect to any defect in a residential water boiler. New Yorker shall have no express obligations, responsibilities or liabilities of any kind, other than those set forth herein.

ALL APPLICABLE IMPLIED WARRANTIES, IF ANY, INCLUDING ANY WARRANTY OF MERCHANT ABILITY OR FITNESS FOR A PARTICULAR PURPOSE, ARE EXPRESSLY LIMITED DURATION TO A PERIOD OF ONE YEAR, EXCEPT THAT IMPLIED WARRANTIES, IF ANY, APPLICABLE TO THE PRESSURE VESSEL OF A RESIDENTIAL WATER BOILER SHALL BE LIMITED IN DURATION TO THE LESSER OF THE DURATION OF SUCH IMPLIED WARRANTY OR A PERIOD EQUAL TO THE TERM OF THE APPLICABLE EXPRESS WARRANTY

Some states do not allow limitations on how long an implied warranty lasts, so the above limitation may not apply to you.

PROCEDURE FOR OBTAINING WARRANTY SERVICE

Upon discovery of a condition believed to be related to a defect in material or workmanship covered by these warranties, the original consumer purchaser should notify the installer, who will in turn notify the distributor. If this action is not possible or does not produce a prompt response, the original consumer purchaser should write to New Yorker Boiler Co., Inc. at P.O. Box 10, Hatfield, PA 19440-0010, giving full particulars in support of the claim.

The original consumer purchaser is required to make available for inspection by New Yorker or its representatives the parts claimed to be defective and, if requested by New Yorker, to ship those parts prepaid to New Yorker at the above address for inspection or repair. In addition, the original consumer purchaser agrees to make all reasonable efforts to settle any disagreement arising in connection with any warranty claim before resorting to legal remedies in the courts.

THIS WARRANTY GIVES YOU SPECIFIC LEGAL RIGHTS AND YOU MAY ALSO HAVE OTHER RIGHTS WHICH VARY FROM STATE TO STATE.



New Yorker
RESIDENTIAL HEATING BOILERS