

# SAFETY.CAT.COM™

## **SAFETY**

Operation and Maintenance  
Manual Excerpt

# Operation and Maintenance Manual

---

## **304.5 Mini Hydraulic Excavator**

---

WAK1-Up (Machine)  
ANR1-Up (Machine)

## Important Safety Information

Most accidents that involve product operation, maintenance and repair are caused by failure to observe basic safety rules or precautions. An accident can often be avoided by recognizing potentially hazardous situations before an accident occurs. A person must be alert to potential hazards. This person should also have the necessary training, skills and tools to perform these functions properly.

**Improper operation, lubrication, maintenance or repair of this product can be dangerous and could result in injury or death.**

**Do not operate or perform any lubrication, maintenance or repair on this product, until you have read and understood the operation, lubrication, maintenance and repair information.**

Safety precautions and warnings are provided in this manual and on the product. If these hazard warnings are not heeded, bodily injury or death could occur to you or to other persons.

The hazards are identified by the "Safety Alert Symbol" and followed by a "Signal Word" such as "DANGER", "WARNING" or "CAUTION". The Safety Alert "WARNING" label is shown below.



The meaning of this safety alert symbol is as follows:

**Attention! Become Alert! Your Safety is Involved.**

The message that appears under the warning explains the hazard and can be either written or pictorially presented.

Operations that may cause product damage are identified by "NOTICE" labels on the product and in this publication.

**Caterpillar cannot anticipate every possible circumstance that might involve a potential hazard. The warnings in this publication and on the product are, therefore, not all inclusive. If a tool, procedure, work method or operating technique that is not specifically recommended by Caterpillar is used, you must satisfy yourself that it is safe for you and for others. You should also ensure that the product will not be damaged or be made unsafe by the operation, lubrication, maintenance or repair procedures that you choose.**

The information, specifications, and illustrations in this publication are on the basis of information that was available at the time that the publication was written. The specifications, torques, pressures, measurements, adjustments, illustrations, and other items can change at any time. These changes can affect the service that is given to the product. Obtain the complete and most current information before you start any job. Caterpillar dealers have the most current information available.



**When replacement parts are required for this product Caterpillar recommends using Caterpillar replacement parts or parts with equivalent specifications including, but not limited to, physical dimensions, type, strength and material.**

**Failure to heed this warning can lead to premature failures, product damage, personal injury or death.**

---

# Safety Section

i01605659

## Operation Warnings

SMCS Code: 7000

**⚠ WARNING**

Failure to follow these instructions can result in serious operator or bystander injury or death.

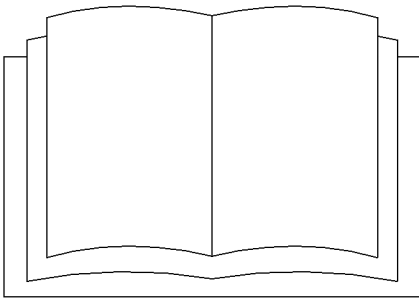

Illustration 2

g00668509

The instructions and the warnings that are given in the Operation and Maintenance Manual must be read, understood, and obeyed before you operate the machine.

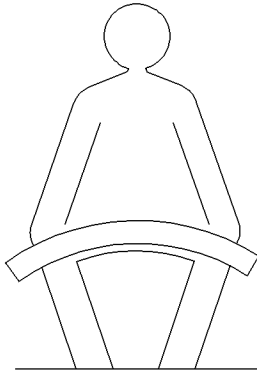

Illustration 3

g00668513

Only operate the controls while you are sitting on the seat in the operator station. The seat belt must be securely fastened.

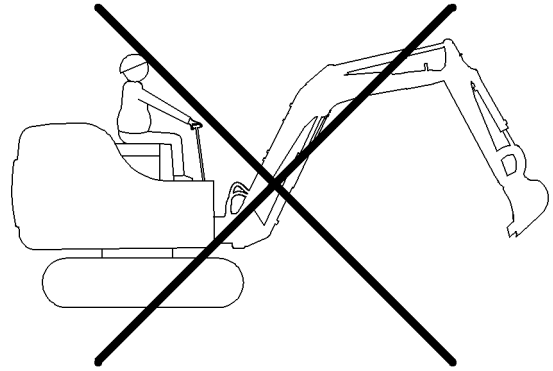

Illustration 4

g00668514

Never operate the machine if any of the following items are removed or disabled: the Falling Object Protective Structure (FOPS), the Tip Over Protective Structure (TOPS), the guards, and the safety devices.

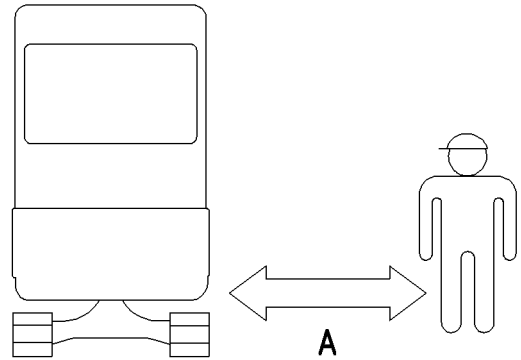

Illustration 5

g00668515

Keep all personnel at a minimum distance (A) of 10 m (33 ft) away from the machine while you are operating the machine. Never carry riders or passengers.

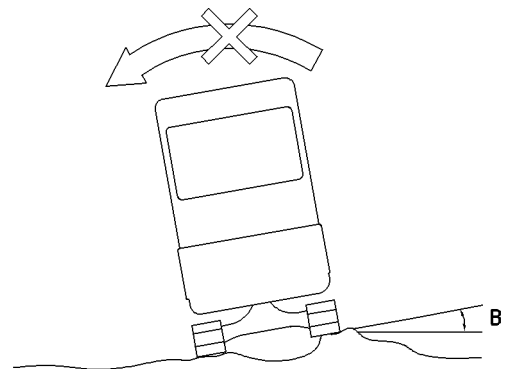

Illustration 6

g00668516

Never travel with the machine when side angle (B) is more than 35 degrees. Moving the machine at a greater angle than 35 degrees may cause the machine to become unstable. Slopes, bumps, and soft ground can increase the side angle. Only operate the joystick controls while the machine is stationary on flat, solid ground. Only operate the foot pedal while the machine is stationary on flat, solid ground. Contact your Caterpillar dealer for information concerning the recommended angles for travel with this machine.

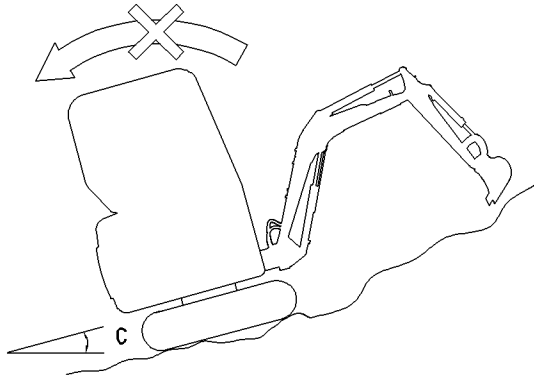

Illustration 7 g00668517

Never travel up grades or back down grades when angle (C) is more than 50 degrees. Moving the machine at a greater angle than 50 degrees may cause the machine to become unstable. Slopes, bumps, and soft ground can increase the angle of the surface. Travel up grades and back down grades with the front linkage extended uphill. The work tool should be no more than 20 cm (8 inches) above the ground. The blade for the dozer must be facing uphill. Contact your Caterpillar dealer for the information concerning the recommended angles for travel with this machine.

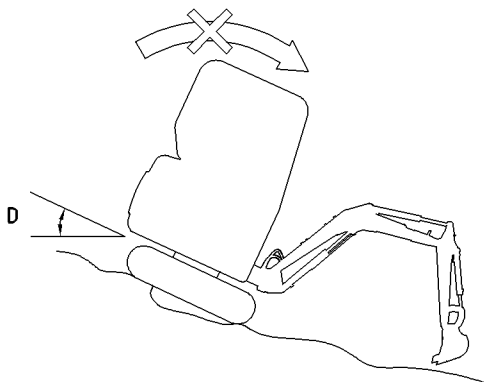

Illustration 8 g00668518

Never travel down grades or back up grades when angle (D) is more than 32 degrees. Moving the machine at a greater angle than 32 degrees may cause the machine to become unstable. Slopes, bumps, and soft ground can increase the angle of the surface. Travel down grades and back up grades with the front linkage extended downhill. The work tool should be no more than 20 cm (8 inches) above the ground. The blade for the dozer must be facing uphill. Contact your Caterpillar dealer for the information concerning the recommended angles for travel with this machine.

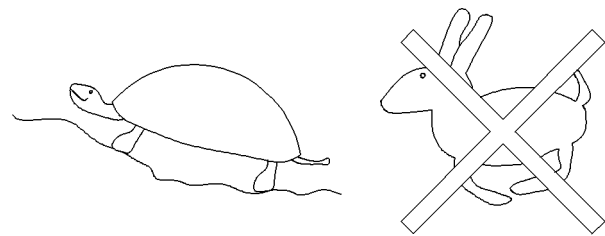

Illustration 9 g00668519

Slowly travel on slopes and over bumps in slow speed. Do not change direction when you travel on slopes. Do not swing the upper structure or the boom while you are moving the machine.

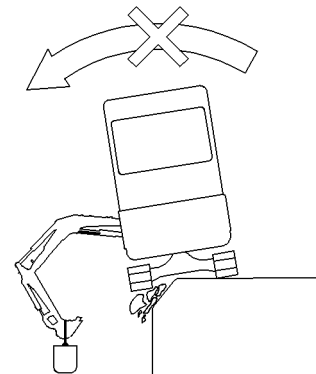

Illustration 10 g00668520

Never operate the machine while the tracks are parallel to a trench or to an edge. Never operate the machine on ground that could compress or collapse. This can cause the machine to tip. Never swing a load over the side of the tracks.

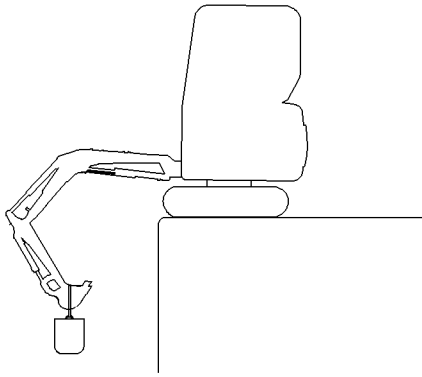

Illustration 11

g00668523

Operate the machine while the tracks are perpendicular to a trench or to an edge. Lift loads and dig only with the boom and the operator's station in line with the tracks. Move the joystick controls slowly.

Use caution when you swing the boom. It may be possible for the work tool to contact the operator's station.

i01683649

## Safety Signs and Labels

**SMCS Code:** 7000; 7405

There are several specific safety signs on this machine. The exact location of the hazards and the description of the hazards are reviewed in this section. Please become familiar with all safety signs.

Make sure that all of the safety signs are legible. Clean the safety signs or replace the safety signs if you cannot read the words. Clean the safety signs or replace the safety signs if the illustrations are not legible. When you clean the safety signs, use a cloth, water and soap. Do not use solvent, gasoline, or other harsh chemicals to clean the safety signs. Solvents, gasoline, or harsh chemicals could loosen the adhesive that secures the safety sign. Loose adhesive will allow the safety sign to detach from the machine.

Replace any safety sign that is damaged, or missing. If a safety sign is attached to a part that is replaced, install a safety sign on the replacement part. Any Caterpillar dealer can provide new safety signs.

## Do Not Operate

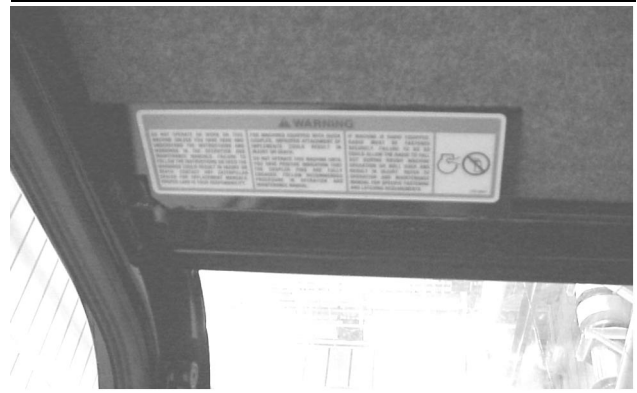

Illustration 12

g00645287

This warning label is located inside the top front of the cab or of the canopy.

### **WARNING**

**Do not operate or work on this machine unless you have read and understand the instructions and warnings in the Operation and Maintenance Manuals. Failure to follow the instructions or heed the warnings could result in injury or death. Contact any Caterpillar dealer for replacement manuals. Proper care is your responsibility.**

**For machines equipped with quick coupler, improper attachment of work tools could result in injury or death.**

**Do not operate this machine until you have positive indication that the coupler pins are fully engaged. Follow recommended procedure in Operation and Maintenance Manual.**

**Securely fasten radio (if equipped) and all loose items such as lunch boxes or tools. Failure to do so could allow items to shift position during rough machine operation or tip over and result in injury. Refer to the Operation and Maintenance Manual for specific fastening and latching requirements.**

## Stay Clear

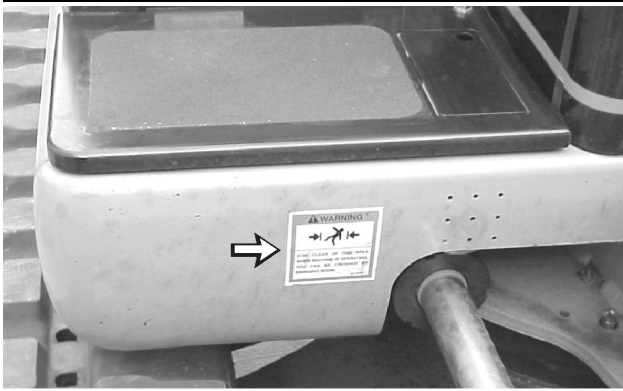

Illustration 13

g00692206

This warning label is located on the frame on both sides of the boom.

### **WARNING**

**Stay clear of this area when machine is operating. You can be crushed by swinging boom.**

## Pressurized System

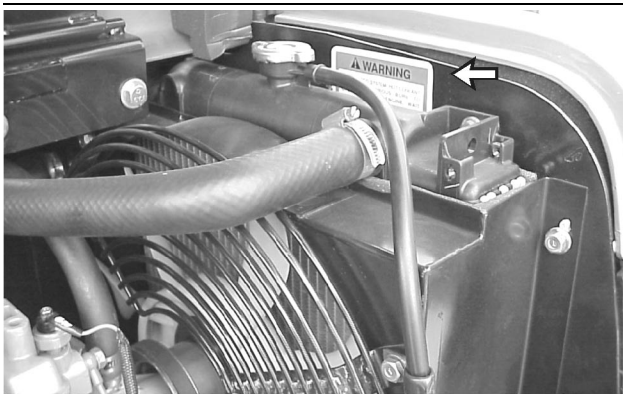

Illustration 14

g00692164

This warning label is located on the inside of the hood above the cooling system filler cap.

### **WARNING**

**Pressurized system: Hot coolant can cause serious burn. To open cap, stop engine, wait until radiator is cool. Then loosen cap slowly to relieve the pressure.**

## Battery



Illustration 15

g00652837

This danger label is located on the top of the battery.

### **DANGER**

#### **Danger/Poison**

**Shield eyes, Explosive gases. Can cause blindness or injury.**

**No sparks, flames or smoking.**

**Sulfuric Acid can cause blindness or severe burns.**

**FLUSH EYES IMMEDIATELY WITH WATER. Seek medical attention immediately.**

**Keep out of reach of children. Contains sulfuric acid. For medical emergency in USA or Canada contact: 800-458-5924, other countries contact: 303-893-1322.**

## Starting with Jump Start Cables

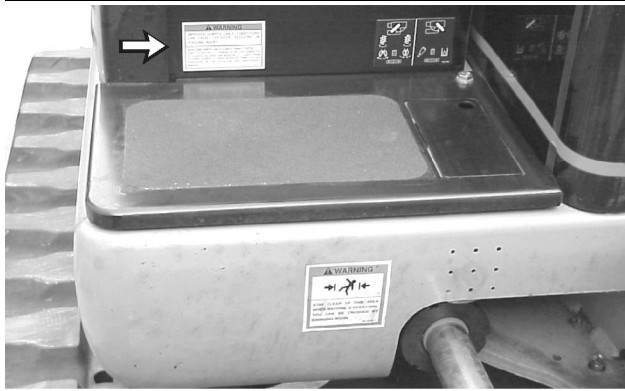

Illustration 16

g00692194

This warning label is located on the panel above the battery.

### **WARNING**

Improper jumper cable connections can cause explosion resulting in personal injury.

When using jumper cables, always connect positive(+) cable to positive(+) terminal of battery connected to starter solenoid and negative(-) cable from external source to engine block or frame. Follow procedure in the Operation and Maintenance Manual.

## High Pressure Cylinder



Illustration 17

g00517418

This warning label is located on the inside surface of the access plate for the track adjuster.

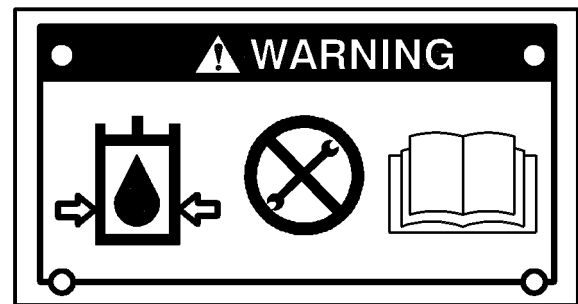

g00100742

### **WARNING**

**High Pressure Cylinder. Do not remove any parts from the cylinder until all of the pressure has been relieved. This will prevent possible personal injury or death.**

Refer to Operation and Maintenance Manual, "Track Adjustment-Inspect/Adjust" for the proper service procedure.



## Height and Reach of Machine



Illustration 18

g00517420

This warning label is located on the left console.

### **WARNING**

**Know the maximum height and reach of your machine. Serious injury or death by electrocution can occur if machine, work tools, or attachments are not kept a safe distance from electrical power lines. Keep distance at least 3 m (10 ft) Plus additional 10 mm (.4 inch) for each 1,000 volts over 50,000 volts.**

## TOPS and FOPS

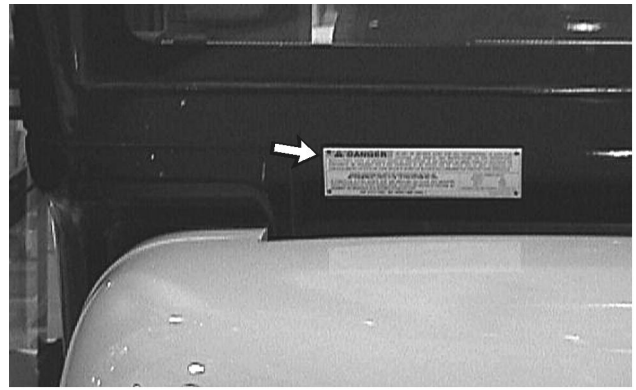

Illustration 19

g00509016

This warning label is located on the rear of the cab or on the canopy above the hood.

### **WARNING**

**Structural damage, an overturn, modification, alteration, or improper repair can impair this structure's protection capability thereby voiding this certification. Do not weld on or drill holes in the structure. Consult a Caterpillar dealer to determine this structure's limitations without voiding its certification.**

## Joystick Control Selector (If Equipped)



Illustration 20 g00868003

This warning label is located inside the top front of the cab or of the canopy.



**Check if control pattern 1 (Standard) or control pattern 2 (Alternate) is selected before operating the machine.**

**Refer to Operation and Maintenance Manual.**

**Failure to understand control functions could result in injury or death.**

## Accumulator Pressure

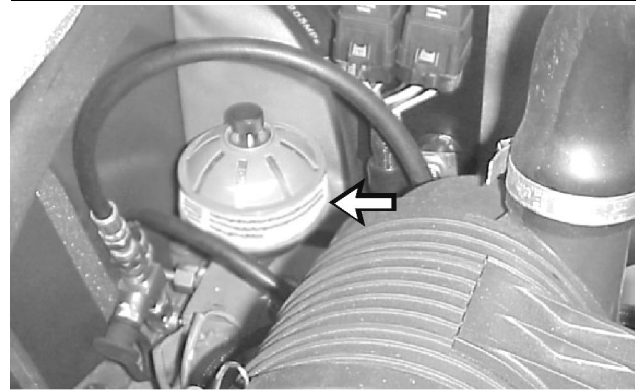

Illustration 21 g00697193

This warning label is located on the Accumulator.



**Contains High Pressure Gas. To avoid explosion and personal injury, do not expose to fire, do not weld, do not drill. Relieve pressure before disassembly. Contact your Caterpillar dealer for proper service procedures.**

## Accumulator Pressure

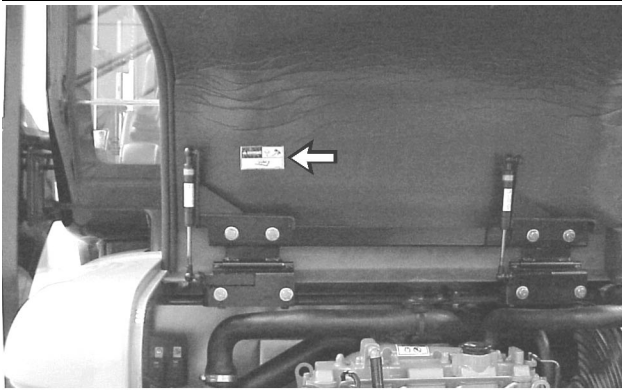
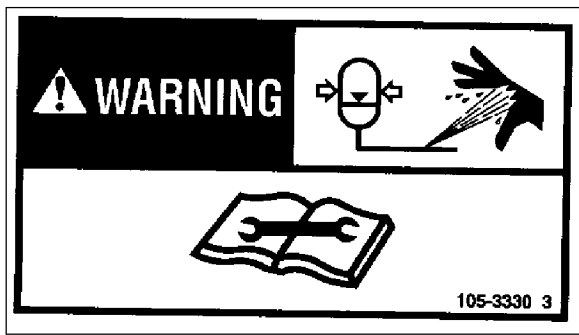

Illustration 22

g00703184

This warning label is located on the left side of the engine access door.



g00659138

### **WARNING**

Accumulator may contain high pressure oil. Do not service the accumulator or any hydraulic lines until all of the pressure has been relieved. See the Service Manual for proper procedures. Failure to heed this warning could result in injury or death.

## Lifting and Tying Down the Machine



Illustration 23

g00868016

This caution is located next to the plate for the machine pin. This caution is used on machines that are delivered into the European Union.

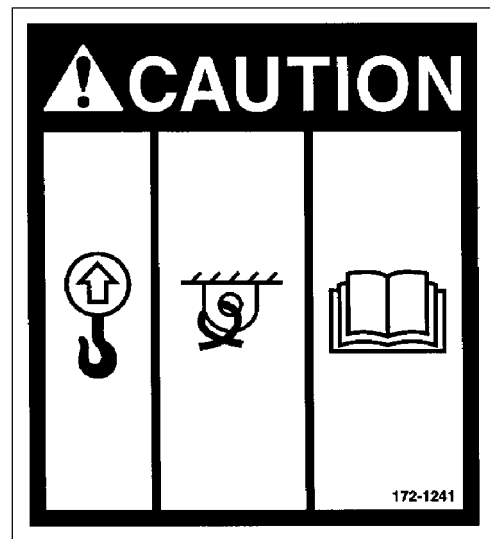

g00868016

### **CAUTION**

Before lifting or tying down this machine, consult Operation and Maintenance Manual, "Transportation Information" for instructions and for calculation of machine mass. Do not use the mass that is stamped on the CE plate for lifting or tying down purposes. Failure to heed this caution could result in injury or property damage.

## Aerosol Starting Aid

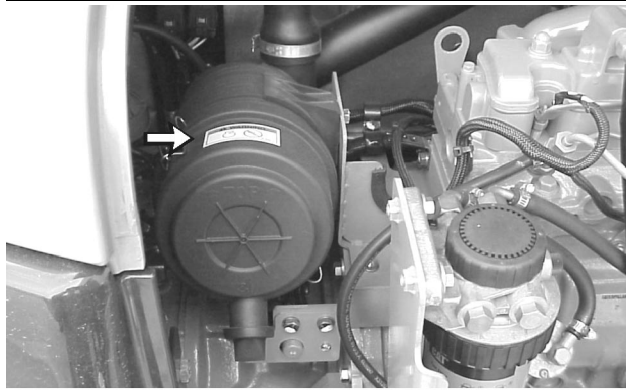

Illustration 24

g00692213

This warning label is located on the air cleaner housing.



g00103679

### **WARNING**

**Do not use aerosol types of starting aids such as ether. Such use could result in an explosion and personal injury.**

i01281391

## General Hazard Information

**SMCS Code:** 7000

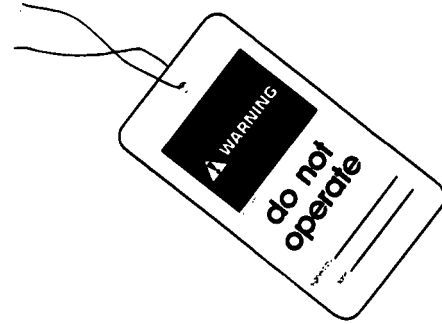

Illustration 25

g00102517

Attach a “Do Not Operate” warning tag or a similar warning tag to the start switch or to the controls before you service the machine or before you repair the machine. These warning tags (Special Instruction, SEHS7332) are available from your Caterpillar dealer.

Know the width of your equipment in order to maintain proper clearance when you operate the machine near fences or near other obstacles.

Wear a hard hat, protective glasses, and other protective equipment, as required.

Do not wear loose clothing or jewelry that can snag on controls or on other parts of the machine.

Make sure that all protective guards and all covers are secured in place on the machine.

Keep the machine free from foreign material. Remove debris, oil, tools, and other items from the cab, from walkways, and from steps.

Secure all loose items such as lunch boxes, tools, and other items that are not a part of the machine.

Know the appropriate work site hand signals and the personnel that are authorized to give the hand signals. Accept hand signals from one person only.

Never put maintenance fluids into glass containers. Drain all liquids into a suitable container.

Obey all local regulations for the disposal of liquids.

Use all cleaning solutions with care. Report all necessary repairs.

Do not allow unauthorized personnel on the machine.

Unless you are instructed otherwise, perform the maintenance under the following conditions:

- The machine is parked on level ground.
- The equipment is lowered to the ground.
- The equipment control levers are in the HOLD position or the STOP position.
- The hydraulic control console is in the RAISED position.
- The engine is stopped.
- The engine start switch key is turned off and the engine start switch key is removed.

## Pressurized Air

Pressurized air can cause personal injury. When pressurized air is used for cleaning, wear a protective face shield, protective clothing, and protective shoes.

The maximum air pressure for cleaning purposes must be below 205 kPa (30 psi).

## Fluid Penetration

Pressure can be maintained in the hydraulic circuit long after the engine has been stopped. The pressure can cause hydraulic fluid or items such as pipe plugs to escape rapidly if the pressure is not relieved correctly.

Do not remove any hydraulic components or parts until pressure has been relieved or personal injury may occur. Do not disassemble any hydraulic components or parts until pressure has been relieved or personal injury may occur.

Perform the following procedures in order to relieve pressure:

1. With the operator in the seat, move the hydraulic control console to the LOWERED position.
2. Ensure that all work tools are lowered to the ground. If the work tools are not on the ground, start the engine and lower the work tools to the ground. Then, stop the engine.
3. Turn the engine start switch key to the ON position.

4. Actuate each control lever about ten times in order to dissipate the pressure in the hydraulic circuit.

5. Turn the engine start switch key to the OFF position. Remove the engine start switch key.

Always use a board or cardboard when you check for a leak. Fluid penetration can cause serious injury and possible death. A pin hole leak can cause severe injury. If fluid is injected into your skin, you must get treatment immediately. Seek treatment from a doctor that is familiar with this type of injury.

The grease that is in the track adjuster is under high pressure. Grease that is under pressure may escape from the relief valve. Grease that escapes can penetrate the skin. Fluid penetration can cause serious injury and possible death.

Do not watch the relief valve while you are adjusting the track. Watch the track or track adjustment cylinder in order to observe if the track is being loosened. Do not loosen the relief valve more than one turn.

## Containing Fluid Spillage

Use care during inspection, maintenance, testing, adjusting and repair of machine in order to ensure that fluids are contained. Obtain a suitable container for fluid before opening any compartment or disassembling any component containing fluids.

Refer to Special Publication, NENG2500, "Tools and Shop Products Guide" for the following items:

- Tools that are suitable for collecting fluids and equipment that is suitable for collecting fluids
- Tools that are suitable for containing fluids and equipment that is suitable for containing fluids

Obey all local regulations for the disposal of liquids.

## Asbestos Information

Caterpillar equipment and replacement parts that are shipped from Caterpillar are asbestos free. Caterpillar recommends the use of only genuine Caterpillar replacement parts. Use the following guidelines when you handle any replacement parts that contain asbestos or when you handle asbestos debris.

Use caution. Avoid inhaling dust that might be generated when you handle components that contain asbestos fibers. Inhaling this dust can be hazardous to your health. The components that may contain asbestos fibers are brake pads, brake bands, lining material, clutch plates, and some gaskets. The asbestos that is used in these components is usually bound in a resin or sealed in some way. The handling of asbestos is not hazardous, unless airborne dust that contains asbestos is generated.

If dust which may contain asbestos is present, there are several guidelines that should be followed.

Never use compressed air for cleaning. Avoid the brushing of materials that contains asbestos or the grinding of materials that contain asbestos. Use a wet method to clean up asbestos debris. A vacuum cleaner that is equipped with a high efficiency particulate air filter (HEPA) can also be used.

Use exhaust ventilation on permanent machining jobs.

Wear an approved respirator if there is no other way to control the dust.

Comply with applicable rules and regulations for the work place. In the USA, use Occupational Safety and Health Administration requirements. These OSHA requirements can be found in "29 CFR 1910.1001".

Obey environmental regulations for disposal of asbestos.

Stay away from areas that might have asbestos particles in the air.

i01270561

## Crushing Prevention and Cutting Prevention

**SMCS Code:** 7000

Support the equipment properly when you work beneath the equipment. Do not depend on the hydraulic cylinders to hold up the equipment. The front linkage can fall if a control is moved, or if a hydraulic line breaks.

Unless you are instructed otherwise, never attempt adjustments while the machine is moving. Also, never attempt adjustments while the engine is running.

Whenever there are work tool linkages, the clearance in the linkage area will increase or the clearance in the linkage area will decrease with movement of the work tool.

Stay clear of all rotating parts. Stay clear of all moving parts.

Keep objects away from moving fan blades. The fan blade will throw objects or cut objects.

Do not use a kinked wire rope cable or a frayed wire rope cable. Wear gloves when you handle wire rope cable.

Make sure that the area is clear of people when you strike a retainer pin. When you strike a retainer pin with force, the retainer pin can fly out. The flying retainer pin can injure personnel.

In order to avoid injury to your eyes, wear protective glasses when you strike a retainer pin.

Chips or other debris can fly off objects when you strike the objects. Make sure that no one can be injured by flying debris before you strike any object.

### Tip Over Protective Structure (TOPS) or Falling Object Protective Structure (FOPS)

Never operate the machine unless the TOPS and the FOPS are properly installed.

These guards are located above the operator's compartment and these guards are secured to the machine.

To avoid the possible weakening of the TOPS or FOPS, consult a Caterpillar dealer before you alter the guards. Do not alter the structure by welding, cutting, adding weight, or drilling holes into the structure.

Any alteration that is not specifically authorized by Caterpillar invalidates the Caterpillar certification for the TOPS and the FOPS. The protection that is offered by the TOPS or by the FOPS will be impaired if the TOPS or the FOPS has structural damage. Damage to the structure can be caused by a tip over, falling objects, etc.

Do not mount fire extinguishers, first aid kits, lights, or other items to the TOPS or to the FOPS. Welding brackets or drilling holes in the TOPS or in the FOPS can weaken the structures. See your Caterpillar dealer for mounting guidelines.

Use caution when you swing the boom. It may be possible for the work tool to contact the operator's station.

## Flying Object Guard (If Equipped)

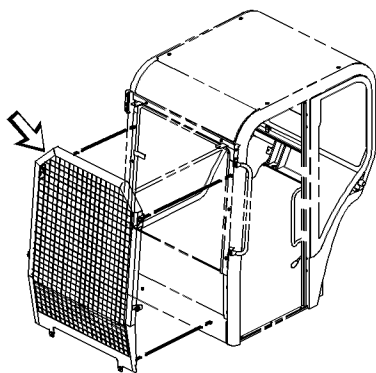

Illustration 26

g00555263

The flying object guard can be mounted on the front of the machine. Use a mesh guard that is approved by Caterpillar on machines that are equipped with a cab. The front window should be down even if a flying object guard is used. Use a mesh guard or use a solid guard that is approved by Caterpillar on machines that are equipped with a canopy. The flying object guard should be installed when a work tool that may create flying objects is used. Always remember to wear your safety glasses, even if the flying object guard is in place.

Consult your work tool Owner's Manual or your work tool Operation and Maintenance Manual in order to determine if using a work tool will require the flying object guard.

i01329099

## Burn Prevention

**SMCS Code:** 7000

Do not touch any part of an operating engine. Allow the engine to cool before any maintenance is performed on the engine. Relieve all pressure in the air system, in the oil system, in the lubrication system, in the fuel system, or in the cooling system before any lines, fittings or related items are disconnected.

### Coolant

When the engine is at operating temperature, the engine coolant is hot. The coolant is also under pressure. The radiator and all lines to the heaters or to the engine contain hot coolant.

Any contact with hot coolant or with steam can cause severe burns. Allow cooling system components to cool before the cooling system is drained.

Check the coolant level only after the engine has been stopped.

Ensure that the filler cap is cool before removing the filler cap. The filler cap must be cool enough to touch with a bare hand. Remove the filler cap slowly in order to relieve pressure.

Cooling system conditioner contains alkali. Alkali can cause personal injury. Do not allow alkali to contact the skin, the eyes, or the mouth.

### Oils

Hot oil and hot components can cause personal injury. Do not allow hot oil to contact the skin. Also, do not allow hot components to contact the skin.

Remove the hydraulic tank filler cap only after the engine has been stopped. The filler cap must be cool enough to touch with a bare hand. Follow the standard procedure in this manual in order to remove the hydraulic tank filler cap.

### Batteries

Electrolyte is an acid. Electrolyte can cause personal injury. Do not allow electrolyte to contact the skin or the eyes. Always wear protective glasses for servicing batteries. Wash hands after touching the batteries and connectors. Use of gloves is recommended.

i01270792

## Fire Prevention and Explosion Prevention

**SMCS Code:** 7000

All fuels, most lubricants, and some coolant mixtures are flammable.

Fuel that is leaking, fuel that is spilled onto hot surfaces, and fuel that is spilled onto electrical components can cause a fire.

Do not smoke while you refuel or while you are in a refueling area.

Do not smoke in battery charging areas or in areas that are used to store flammable material.

Batteries can be installed in separate compartments. When you use jump start cables, always connect the positive “+” cable to the positive “+” terminal of the battery that is connected to the starter solenoid. Connect the negative “-” cable that is from the external source to the negative “-” terminal of the starter or frame.

**Note:** If the starter is not equipped with a negative “-” terminal, connect the cable to the engine block.

See the Operation Section of this manual for specific starting instructions.

Clean all electrical connections and tighten all electrical connections. Check the electrical wires daily for loose wires or for frayed wires. Tighten all loose wires before you operate the machine. Repair all frayed wires before you operate the machine.

Store all fuels and lubricants in properly marked containers and away from all unauthorized persons.

Store all oily rags or other flammable material in a protective container.

Do not weld pipes that contain flammable fluids or tubes that contain flammable fluids. Do not flame cut pipes that contain flammable fluids or tubes that contain flammable fluids. Clean the pipes or tubes thoroughly with nonflammable solvent before you weld the pipes or tubes or when you flame cut the pipes or tubes.

Remove all flammable materials (fuel, oil, debris, etc) before the flammable materials accumulate on the machine.

Do not expose the machine to flames or to brush that is burning.

Shields protect hot exhaust components from oil spray or fuel spray. Make sure that the shields are installed correctly in case a line, a tube, or a seal fails.

## Ether

Do not spray ether into an engine when you use thermal starting aid to start the engine.

Ether is poisonous and flammable. Inhaling ether vapors can cause personal injury. Do not allow ether to contact your skin repeatedly. Use ether only in well ventilated areas. Do not smoke while you replace ether cylinders. Use ether carefully to avoid fires. Do not store ether cylinders in living areas or in the operator’s compartment.

Do not store ether cylinders in direct sunlight or at temperatures above 49 °C (120 °F). Discard ether cylinders in an approved place. Do not puncture ether cylinders. Do not burn ether cylinders. Keep ether cylinders out of the reach of unauthorized personnel.

## Lines, Tubes and Hoses

Do not bend high pressure lines. Do not strike high pressure lines. Do not install bent lines, bent tubes, or bent hoses. Do not install damaged lines, damaged tubes, or damaged hoses.

Repair loose lines, loose tubes, and loose hoses. Repair damaged lines, damaged tubes, and damaged hoses. Leaks can cause fires. See your Caterpillar dealer for repair or for replacement parts.

Check lines, tubes and hoses carefully. Do not use your bare hand to check for leaks. Use a board or cardboard to check for leaks. See Operation and Maintenance Manual, “General Hazard Information” for more details. Tighten all connections to the recommended torque.

Replace the lines, tubes or hoses if any of the following conditions are present:

- End fittings that are damaged or leaking
- Outer coverings that are chafed or cut
- Wire shields that are exposed
- Outer coverings that are ballooning
- Flexible part of the hoses that are kinked
- Outer covers that have embedded armoring
- End fittings that are displaced

Make sure that all clamps, guards, and heat shields are installed correctly. This will help prevent vibration, rubbing against other parts, and excessive heat during machine operation.

i01263627

## Fire Extinguisher Location

**SMCS Code:** 7000; 7419

Make sure that a fire extinguisher is available. Be familiar with the operation of the fire extinguisher and service the fire extinguisher regularly. Obey the recommendations on the instruction plate.



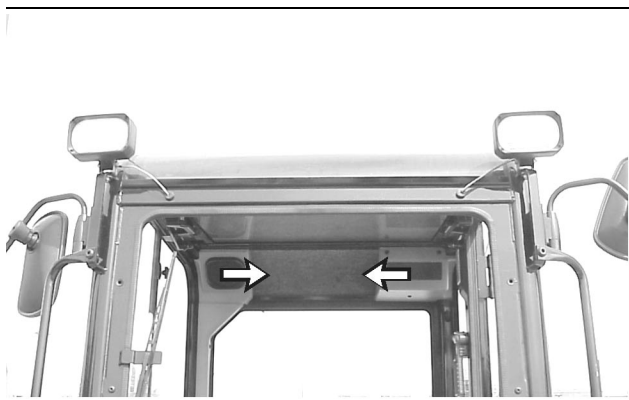

Illustration 27

g00645409

A fire extinguisher can be installed above the back of the operator seat.

Consult your Caterpillar dealer for the installation of the fire extinguisher.

i01329108

## Track Information

**SMCS Code:** 4170; 7000

Track adjusting systems use either grease or oil under high pressure to keep the track under tension.

Grease or oil under high pressure coming out of the relief valve can penetrate the body causing injury or death. Do not watch the relief valve to see if grease or oil is escaping. Watch the track or track adjustment cylinder to see if the track is being loosened.

The pins and bushings in a dry track pin joint can become very hot. It is possible to burn the fingers if there is more than brief contact with these components.

i01122596

## Electrical Storm Injury Prevention

**SMCS Code:** 7000

When lightning is striking in the vicinity of the machine, the operator should never attempt the following procedures:

- Mount the machine.
- Dismount the machine.

If you are in the operator's station during an electrical storm, stay in the operator's station. If you are on the ground during an electrical storm, stay away from the vicinity of the machine.

i01328074

## Mounting and Dismounting

**SMCS Code:** 7000

- Get on the machine only at locations that are equipped with steps and/or handholds. Get off the machine only at locations that are equipped with steps and/or handholds.
- Before you get on the machine, clean the floor of the operator station and the handholds. Inspect the handholds. Make all necessary repairs.



Illustration 28

g00037367

- Face the machine whenever you mount the machine and whenever you dismount the machine.
- Maintain a three-point contact with the steps and the handholds.

**Note:** Three-point contact can be two feet and one hand. Three-point contact can also be one foot and two hands.

- Do not mount a moving machine. Do not dismount a moving machine.
- Never jump off the machine.
- Do not try to mount the machine if you are carrying tools or supplies. Do not try to dismount the machine if you are carrying tools or supplies. Use a hand line to pull equipment onto the platform.
- Do not use any controls as handholds when you enter the operator's compartment or when you exit the operator's compartment.

- Before you dismount the machine, move the hydraulic console and the seat to the rearmost position.

## Alternate Exit

Machines that are equipped with cabs have alternate exits. For additional information, see Operation and Maintenance Manual, "Alternate Exit".

i01186721

## Before Starting Engine

**SMCS Code:** 1000; 7000

Start the engine only from the operator's compartment. Do not short across the battery terminals and do not short across the battery. Bypassing the engine neutral start system can damage the electrical system.

Inspect the condition of the seat belt and the condition of the mounting hardware. Replace any damaged parts or worn parts. Regardless of appearance, replace the seat belt after three years of use. Do not use an extension for a seat belt on a retractable seat belt.

Adjust the seat so that full pedal travel can be achieved. Adjust the seat so that full lever travel can be achieved. Make sure that your back is against the back of the seat.

Make sure that the machine is equipped with a lighting system that is adequate for the job conditions. Make sure that all lights are working properly.

Make sure that the hydraulic control console is in the RAISED position. When the hydraulic control console is in the RAISED position, the hydraulic controls will be deactivated.

### **WARNING**

**Deactivation of the hydraulic controls does not prevent the blade, boom swing, or auxiliary circuit functions from moving under gravity or other external forces. Gravity or other external forces can move the blade, boom swing, or auxiliary circuit functions suddenly if a hydraulic control lever is moved.**

**Personal injury or death may occur from sudden machine movement.**

Put the cover on the control pedal for the swinging boom. Put the cover on the auxiliary hydraulic control.

Before you start the engine and before you move the machine, make sure that no personnel are underneath the machine, around the machine, or on the machine. Make sure that the area is free of personnel.

i01009165

## Engine Starting

**SMCS Code:** 1000; 7000

If a warning tag is attached to the start switch or to the controls, do not start the engine. Also, do not move any controls.

Move all hydraulic controls to the HOLD position or to the STOP position before you start the engine.



Illustration 29

g00517433

Put the hydraulic control console in the RAISED position.

Diesel engine exhaust contains products of combustion which can be harmful to your health. Always start the engine in a well ventilated area. Always operate the engine in a well ventilated area. If you are in an enclosed area, vent the exhaust to the outside.

i01591861

## Before Operation

**SMCS Code:** 7000

A video tape is available in English for this machine. This video tape is in a North American format. Contact your Caterpillar dealer in order to obtain a copy of Mini Excavator Safety and Operating Tips, AENV4291. The video tape should be viewed by every person before operating the machine.

Only use Caterpillar approved work tools on this machine. Refer to Operation and Maintenance Manual, "Caterpillar Approved Work Tools" for a list of Caterpillar approved work tools for this machine.

Clear all personnel from the machine and from the area.

Clear all obstacles from the path of the machine. Beware of hazards such as wires, ditches, etc.

Make sure that all windows are clean. Secure the doors in the open position or in the shut position. Secure the windows in the open position or in the shut position.

For the best vision of the area that is close to the machine, adjust the rear view mirrors (if equipped).

Make sure that the machine horn, the travel alarm (if equipped) and all other warning devices are working properly.

Fasten the seat belt securely.

i01328101

## Work Tools

**SMCS Code:** 6700

Only use work tools that are approved by Caterpillar for use on Caterpillar machines. Refer to the Operation and Maintenance Manual, "Caterpillar Approved Work Tools".

If you are in doubt about the compatibility of a particular work tool with your machine, consult your Caterpillar dealer.

Make sure that all necessary guarding is in place on the host machine and on the work tool.

Keep all windows and doors closed on the host machine. Always wear protective glasses. Always wear the protective equipment that is recommended in the work tool's operation manual. Wear any other protective equipment that is required for the operating environment.

To prevent personnel from being struck by flying objects, ensure that all personnel are out of the work area.

While you are performing any maintenance, any testing, or any adjustments to the work tool stay clear of the following areas: cutting edges, pinching surfaces, and crushing surfaces.

Use caution when you swing the boom. It may be possible for the work tool to contact the operator's station.

i01591871

## Operation

**SMCS Code:** 7000

Only operate the machine while you are in a seat. The seat belt must be fastened while you operate the machine. Only operate the controls while the engine is running.

While you operate the machine slowly in an open area, check for proper operation of all controls and all protective devices.

Before you move the machine, you must be certain that no one will be endangered.

Do not allow riders on the machine.

Note any needed repairs during machine operation. Report any needed repairs.

Carry work tools approximately 400 mm (16 inch) above ground level. Do not go close to the edge of a cliff, an excavation, or an overhang.

If the machine begins to sideslip downward on a grade, immediately remove the load and turn the machine downhill.

Avoid any conditions that can lead to tipping the machine. The machine can tip when you work on hills, on banks and on slopes. Also, the machine can tip when you cross ditches, ridges or other obstacles.

Avoid operating the machine across the slope. When possible, operate the machine up the slopes and down the slopes.

Maintain control of the machine. Do not overload the machine beyond the machine capacity.

Be sure that the hitches and the towing devices are adequate.

Only connect the trailing equipment to a drawbar or to a hitch.

Never straddle a wire cable. Never allow other personnel to straddle a wire cable.

Before you connect the machine to trailing equipment, make sure that no personnel are between the machine and the trailing equipment. Block up the hitch of the trailing equipment in order to align the hitch with the drawbar. Connect the machine to the trailing equipment.

Know the maximum dimensions of your machine.

Always keep the Tip Over Protection Structure (TOPS) installed during machine operation.

This machine is designed to operate in the ambient temperature range of  $-20\text{ }^{\circ}\text{C}$  ( $-4\text{ }^{\circ}\text{F}$ ) to  $41\text{ }^{\circ}\text{C}$  ( $106\text{ }^{\circ}\text{F}$ ).

i01591879

## Lifting Objects

**SMCS Code:** 7000

There may be some local regulations and/or government regulations that govern the use of excavators which lift heavy objects. Obey those regulations.

i01591878

## Parking

**SMCS Code:** 7000

When an accumulator has a charge, the hydraulic equipment is active. The accumulator may have a charge even if the engine is not running. When the accumulator is used to activate the hydraulic circuit, the charge should bleed off in less than one minute. Movement can occur under the following conditions:

- The ignition key is in the ON position.
- The hydraulic control console is in the LOWERED position.
- The work tool is not positioned on the ground.

### **WARNING**

**Deactivation of the hydraulic controls does not prevent the blade, boom swing, or auxiliary circuit functions from moving under gravity or other external forces. Gravity or other external forces can move the blade, boom swing, or auxiliary circuit functions suddenly if a hydraulic control lever is moved.**

**Personal injury or death may occur from sudden machine movement.**

1. Park on a level surface. If it is necessary to park on a grade, chock the tracks.



Illustration 30

g00696298

2. Lower the work tools and the blade to the ground.
3. Move the governor control lever to the LOW idle position and operate the engine at low idle for five minutes in order to allow the engine to cool down.
4. Turn the engine start switch to the OFF position.
5. When the engine has stopped, turn the engine start switch key to the ON position.
6. Move the hydraulic control levers back and forth in order to relieve hydraulic pressure.

**Note:** The hydraulic control console must be lowered in order for the hydraulic circuit to be activated.

7. Turn the engine start switch to the OFF position and remove the key.



Illustration 31

g00517433

8. Place the hydraulic control console in the RAISED position.

i01271415

## Equipment Lowering with Engine Stopped

SMCS Code: 7000-II

### WARNING

Personal injury or death can result from boom lowering.

The boom can drop when lowering it with the engine stopped.

Keep all personnel away from the boom drop area when lowering the boom with the engine stopped.

Be sure no one is under or near the front linkage before manually lowering the boom.

## Lowering the Equipment with the Accumulator Charged

If electrical power is available and the accumulator is charged, the boom can be lowered from the operator station with the joystick.

1. Turn the engine start switch key to the ON position.
2. Lower the hydraulic control console.
3. Slowly, move the joystick to the BOOM LOWER position in order to lower the boom slowly.

If the boom does not lower, the accumulator is not charged. It is possible to recharge the accumulator by cranking the engine for a period of fifteen to twenty seconds. Repeat step 3.

If there is no electrical power the boom must be lowered manually. See Operation and Maintenance Manual, "Lowering the Equipment with the Accumulator Discharged" for more details.

## Lowering the Equipment with the Accumulator Discharged

### WARNING

Personal injury can result from oil under high pressure.

DO NOT allow high pressure oil to contact skin.

Wear appropriate protective equipment while working with high pressure oil systems.

If there is no electrical power or the accumulator is not charged, the boom cannot be lowered with the joystick. The boom must be lowered manually.

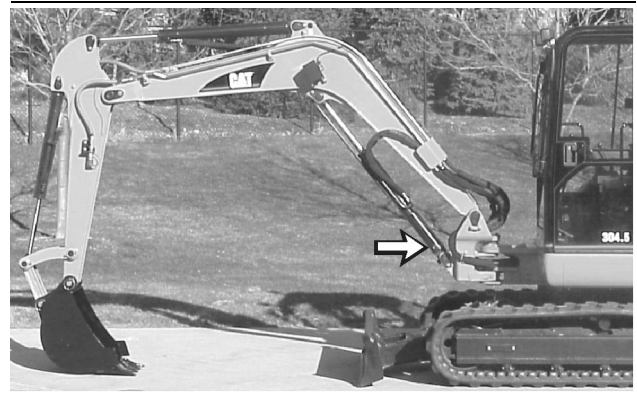

Illustration 32

g00696304

**Note:** Refer to Operation and Maintenance Manual, "General Hazard Information" for information on Containing Fluid Spillage.

1. Connect a hose to the boom manual lowering valve on the boom cylinder.
2. Slowly open the boom manual lowering valve in order to lower the boom. Drain hydraulic oil into a suitable container.
3. Close the boom manual lowering valve when the boom is lowered to the ground.
4. Make the necessary repairs before you operate the machine.
5. Check the level of the hydraulic fluid. Refer to Operation and Maintenance Manual, "Hydraulic System Oil Level-Check".

## Sound Information and Vibration Information

**SMCS Code:** 7000

### Sound Information and Vibration Information for Machines Offered in European Union Countries

The operator sound pressure level for machines with a cab is 82 dB(A). The sound levels are measured using dynamic test procedures and conditions specified in "ISO 6396" or "95/27/EC".

The operator sound pressure level for machines with a canopy is 80 dB(A). The sound levels are measured according to dynamic test procedures and conditions specified in "ISO 6396" or "95/27/EC".

As manufactured by Caterpillar, this machine's exterior sound power level meets the criteria specified in the European Directives noted on the certificate of conformance and the accompanying labels.

### Vibration Level

The hands and arms are exposed to a weighted root mean square acceleration that is less than 2.5 m/sec<sup>2</sup>.

The whole body is exposed to a weighted root mean square acceleration that is 0.5 m/s<sup>2</sup>.

Measurements are obtained on a representative machine using the procedures in the following standards:

- "ISO 2631/1"
- "ISO 5349"
- "SAE J1166"

## Operator Station

**SMCS Code:** 7300; 7301; 7325

Any modifications to the inside of the operator station should not project into the operator space. The addition of a radio, fire extinguisher, and other equipment must be installed so that the defined operator space is maintained. Any item that is brought into the cab should not project into the defined operator space. A lunch box or other loose items must be secured. Objects must not pose an impact hazard in rough terrain or in the event of a rollover.

## Guards (Operator Protection)

**SMCS Code:** 7000; 7150

There are different types of guards that are used to protect the operator. The machine and the machine application determines the type of guard that should be used.

A daily inspection of the guards is required in order to check for structures that are bent, cracked or loose. Never operate a machine with a damaged structure.

The operator becomes exposed to a hazardous situation if the machine is used improperly or if poor operating techniques are used. This situation can occur even though a machine is equipped with an appropriate protective guard. Follow the established operating procedures that are described in the Operation and Maintenance Manual, "Operating Techniques" information.

---

## **Rollover Protective Structure (ROPS), Falling Object Protective Structure (FOPS) or Tip Over Protection Structure (TOPS)**

The ROPS/FOPS Structure (if equipped) on your machine is specifically designed, tested and certified for that machine. Excavators are not equipped with ROPS structures. Any alteration or any modification to the ROPS/FOPS Structure could weaken the structure. This places the operator into an unprotected environment. Modifications or attachments that cause the machine to exceed the weight that is stamped on the certification plate also place the operator into an unprotected environment. Excessive weight may inhibit the brake performance, the steering performance and the ROPS. The protection that is offered by the ROPS/FOPS Structure will be impaired if the ROPS/FOPS Structure has structural damage. Damage to the structure can be caused by an overturn, a falling object, a collision, etc.

Do not mount items (fire extinguishers, first aid kits, work lights, etc) by welding brackets to the ROPS/FOPS Structure or by drilling holes in the ROPS/FOPS Structure. Welding brackets or drilling holes in the ROPS/FOPS Structures can weaken the structures. Consult your Caterpillar dealer for mounting guidelines.

The Tip Over Protection Structure (TOPS) is another type of guard that is used on mini-hydraulic excavators. This structure protects the operator in the event of a tipover. The same guidelines for the inspection, the maintenance and the modification of the ROPS/FOPS Structure are required for the Tip Over Protection Structure.

## **Other Guards (If Equipped)**

Protection from flying objects and/or falling objects is required for special applications. Logging applications and demolition applications are two examples that require special protection.

A front guard needs to be installed when a work tool that creates flying objects is used. Mesh front guards that are approved by Caterpillar or polycarbonate front guards that are approved by Caterpillar are available for machines with a cab or an open canopy. On machines that are equipped with cabs, the windshield should also be closed. Safety glasses are recommended when flying hazards exist for machines with cabs and machines with open canopies.

If the work material extends above the cab, top guards and front guards should be used. Typical examples of this type of application are listed below:

- Demolition applications
- Rock quarries
- Forestry products

Additional guards may be required for specific applications or work tools. The Operation and Maintenance Manual for your machine or your work tool will provide specific requirements for the guards. Consult your Caterpillar dealer for additional information.