



TB7100 Base Station

Installation and Operation Manual

MBB-00001-04
Issue 4
November 2007

Contact Information

Tait Radio Communications Corporate Head Office

Tait Electronics Limited
P.O. Box 1645
Christchurch
New Zealand

For the address and telephone number of regional offices, refer to the TaitWorld website:

Website: www.taitworld.com

Technical Support

For assistance with specific technical issues, contact Technical Support:

E-mail: support@taitworld.com

Website: www.taitworld.com/technical

Copyright and Trademarks

All information contained in this document is the property of Tait Electronics Limited. All rights reserved. This document may not, in whole or in part, be copied, photocopied, reproduced, translated, stored, or reduced to any electronic medium or machine-readable form, without prior written permission from Tait Electronics Limited.

The word TAIT and the TAIT logo are trademarks of Tait Electronics Limited.

All trade names referenced are the service mark, trademark or registered trademark of the respective manufacturers.

Disclaimer

There are no warranties extended or granted by this document. Tait Electronics Limited accepts no responsibility for damage arising from use of the information contained in the document or of the equipment and software it describes. It is the responsibility of the user to ensure that use of such information, equipment and software complies with the laws, rules and regulations of the applicable jurisdictions.

Enquiries and Comments

If you have any enquiries regarding this document, or any comments, suggestions and notifications of errors, please contact Technical Support.

Updates of Manual and Equipment

In the interests of improving the performance, reliability or servicing of the equipment, Tait Electronics Limited reserves the right to update the equipment or this document or both without prior notice.

Intellectual Property Rights

This product may be protected by one or more patents of Tait Electronics Limited together with their international equivalents, pending patent applications and registered trade marks: NZ338097, NZ508054, NZ508340, NZ508806, NZ508807, NZ509242, NZ509640, NZ509959, NZ510496, NZ511155, NZ511421, NZ516280/519742, NZ519118, NZ519344, NZ520650/537902, NZ522236, NZ524369, NZ524378, NZ524509, NZ524537, NZ524630, NZ530819, NZ534475, NZ534692, NZ535471, NZ536945, NZ537434, NZ546295, NZ547713, NZ521450, AU2003281447, AU2002235062, AU2004216984, AU2005207405, CA2439018, CA2554213, EU03784706.8, EU02701829.0, EU04714053.8, EU05704655.9, GB23865476, GB2386010, GB2413249, GB0516092.4, US11,232716, US10/597339, US10/520827, US10/468740, US5,745,840, US10/547653, US10/546696, US10/547964, US10/523952, US11/572700.

Environmental Responsibilities



Tait Electronics Limited is an environmentally responsible company which supports waste minimization, material recovery and restrictions in the use of hazardous materials.

The European Union's Waste Electrical and Electronic Equipment (WEEE) Directive requires that this product be disposed of separately from the general waste stream when its service life is over. For more information about how to dispose of your unwanted Tait product, visit the Tait Electronics WEEE website at www.taitworld.com/weee. Please be environmentally responsible and dispose through the original supplier, or contact Tait Electronics Limited.

Tait Electronics Limited also complies with the Restriction of the Use of Certain Hazardous Substances in Electrical and Electronic Equipment (RoHS) Directive in both the European Union and China.

In China, we comply with the Measures for Administration of the Pollution Control of Electronic Information Products. We will comply with environmental requirements in other markets as they are introduced.

Contents

Preface	7
Scope of Manual	7
Document Conventions	7
Associated Documentation	7
Publication Record	8
1 Introduction	9
1.1 Frequency Bands	10
1.2 RF Output Power	10
1.3 Power Supply Options	11
1.4 Product Codes	11
2 Functional Description	13
2.1 Receiver Operation	15
2.1.1 RF Hardware	15
2.1.2 Digital Baseband Processing	16
2.1.3 Audio Processing and Signalling	17
2.2 Transmitter Operation	18
2.2.1 Audio Processing and Signalling	18
2.2.2 Frequency Synthesizer	19
2.2.3 RF Power Amplifier	22
2.3 User Interface Operation	23
2.4 System Interface Operation	27
2.4.1 Internal Power Distribution	29
2.4.2 Serial Data	30
2.4.3 General Purpose IO	30
2.4.4 Receiver Audio Processing	30
2.4.5 Tone On Idle	30
2.4.6 Transmitter Audio Processing	31
2.4.7 Opto-Isolated Keying	31
2.4.8 Rx Relay	31
2.4.9 Relay Driver	31
2.4.10 Fan Control	31
2.4.11 RSSI	31
2.4.12 Receiver Gate	31
2.4.13 Receiver Inhibit	32
2.5 Fan Operation	32
3 Installation	33
3.1 Personal Safety	33
3.1.1 Lethal Voltages	33
3.1.2 AC Power Connection	34
3.1.3 Explosive Environments	34
3.1.4 Proximity to RF Transmissions	34

3.1.5	High Temperatures	34
3.1.6	LED Safety (EN60825-1)	34
3.2	Equipment Safety	35
3.2.1	ESD Precautions	35
3.2.2	Antenna Load	35
3.2.3	Equipment Grounding	35
3.2.4	Installation and Servicing Personnel	36
3.3	Regulatory Information	36
3.3.1	Distress Frequencies	36
3.3.2	FCC Compliance	36
3.3.3	Unauthorised Modifications.	36
3.3.4	Health, Safety and Electromagnetic Compatibility in Europe.	36
3.4	Environmental Conditions	37
3.4.1	Operating Temperature Range	37
3.4.2	Humidity	37
3.4.3	Dust and Dirt	37
3.5	Grounding and Lightning Protection.	37
3.5.1	Electrical Ground	37
3.5.2	Lightning Ground.	38
3.6	Recommended Tools	38
3.7	Ventilation.	38
3.8	Installing the Base Station	40
3.8.1	Unpacking the Equipment.	40
3.8.2	Power Supply Options	41
3.8.3	Mounting the Base Station	42
3.8.4	Cabling	43
3.8.5	Accessories	43
4	Connections	45
4.1	External Connectors.	46
4.2	Internal Connectors	51
4.2.1	Transmitter and Receiver Connectors	51
4.2.2	SI Board Connectors.	53
4.2.3	UI Board Connectors	55
5	Opening and Closing the Base Station	57
6	Preparation for Operation.	59
6.1	Introduction.	59
6.2	Mode of Operation	60
6.3	Line-controlled Base.	61
6.3.1	Test Equipment Required.	61
6.3.2	Test Equipment Setup.	62
6.3.3	Link Settings.	64
6.3.4	Applying Power	65
6.3.5	Programming	66
6.3.6	Receiver Audio Level Adjustment	67
6.3.7	Receiver Functional Testing	68

6.3.8	Transmitter Audio Level Adjustment	69
6.3.9	Transmitter Functional Testing	70
6.4	Talk Through Repeater	71
6.4.1	Test Equipment Required	72
6.4.2	Test Equipment Setup	72
6.4.3	Link Settings	72
6.4.4	Applying Power	74
6.4.5	Programming	74
6.4.6	Audio Level Adjustment	74
6.4.7	Talk Through Repeater Functional Testing	74
6.4.8	Alternate Talk Through Repeater Configuration	75
6.5	RF Modem	76
6.5.1	Test Equipment Required	76
6.5.2	Test Equipment Setup	77
6.5.3	Link Settings	77
6.5.4	Applying Power	79
6.5.5	Programming	79
6.5.6	Audio Level Adjustment	79
6.5.7	Programming for FFSK Operation	79
6.5.8	Programming for THSD Operation	81
6.5.9	Verification	84
6.6	Data Repeater	85
6.6.1	Link Settings	85
6.6.2	Applying Power	86
6.6.3	Programming	87
6.6.4	Audio Level Adjustment	87
6.6.5	Data Repeater Functional Testing	87
6.7	TaitNet Trunking	88
6.8	Programmable Features	88
6.8.1	Connecting to the PC	88
6.8.2	TB7100 Programming Application	88
6.8.3	Mandatory Settings	90
6.8.4	User-defined Settings	91
6.8.5	Recommended Settings	95
6.8.6	Function Keys	96
6.9	Additional Settings	98
6.10	Adding Subaudible Signalling	98
6.10.1	Enabling Subaudible Signalling	98
6.10.2	Testing Subaudible Signalling	99
6.10.3	Multiple Subaudible Tones	99
6.11	Soft Off (Tx Tail Time)	100
6.12	Tone On Idle (TOI)	102
6.13	Fan Operation	103
6.14	External Channel Selection	104
6.15	Relay Polarity	105
6.16	Channel Increment and Decrement by Function Keys	106
6.17	Continuous Wave Identification (CWID)	106

6.18 Configuring F1 and F2	106
7 Maintenance Guide	107
Glossary	109
Directive 1999/5/EC Declaration of Conformity	121

Preface

Scope of Manual

Welcome to the TB7100 Installation and Operation Manual. This manual provides information on installing and operating the TB7100 base station. Also included in this manual are a high-level circuit description, a functional description and a maintenance guide.

Document Conventions

“File > Open” means “click File on the menu bar, then click Open on the list of commands that pops up”. “Channel Setup > Channels > Detailed” means “in the navigation pane find the Channel Setup group, and select Channels from it, on the Channels page select the Detailed tab”.

Within this manual, four types of alerts are given to the reader: Warning, Caution, Important and Note. The following paragraphs illustrate each type of alert and its associated symbol.



Warning!! This alert is used when there is a potential risk of death or serious injury.



Caution This alert is used when there is a risk of minor or moderate injury to people.



Important This alert is used to warn about the risk of equipment damage or malfunction.



Note This alert is used to highlight information that is required to ensure procedures are performed correctly.

Associated Documentation

The following associated documentation is available for this product:

- MBB-00002-xx TB7100 Specifications Manual
- MBB-00003-xx TB7100 Installation Guide
- MBB-00006-xx TB7100 Installation Guide (French)
- MBB-00007-xx TB7100 Installation Guide (Spanish)
- MBB-00008-xx TB7100 Installation Guide (Chinese)
- MBB-00005-xx TB7100 Service Manual

- MBA-00013-**xx** TBA0STU/TBA0STP Calibration and Test Unit Operation Manual

The characters **xx** represent the issue number of the documentation.

All available documentation is provided on the CD (406-00047-**xx**) supplied with the base station. Updates may also be published on the Tait support website.

Technical notes are published from time to time to describe applications for Tait products, to provide technical details not included in manuals, and to offer solutions for any problems that arise.

Publication Record

Issue	Publication Date	Description
1	May 2005	First release
2	December 2005	Internal AC power supply, A4 and D1 bands added.
3	March 2006	C0 and G2 bands added.
4	November 2007	General updates for firmware release 2.15.00.05. THSD anti-collision feature added on page 30 .

1 Introduction

Figure 1.1 TB7100 base stations

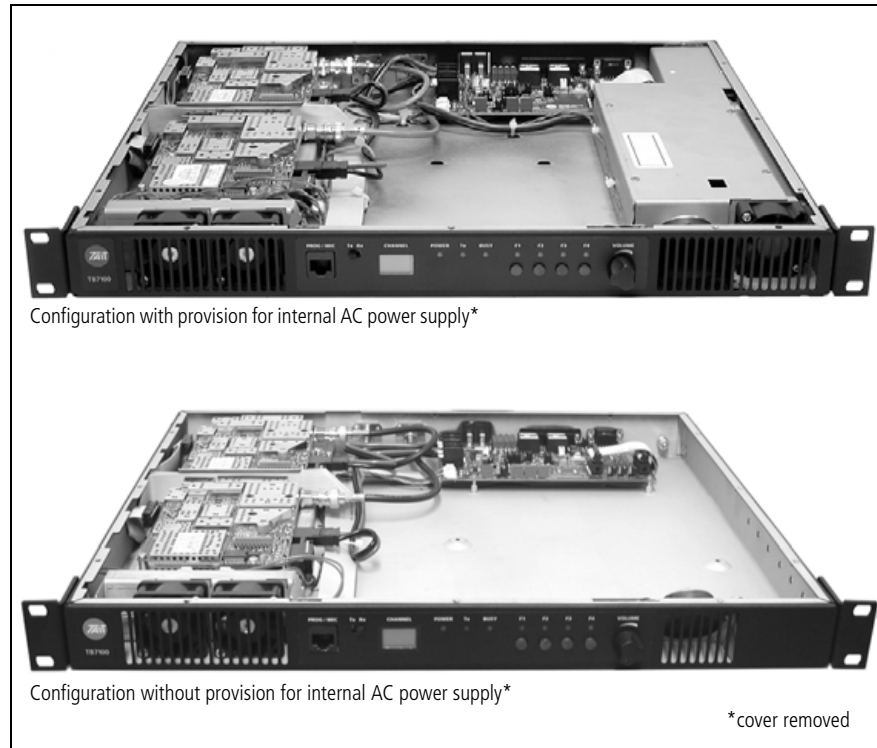

The TB7100 is a software and hardware link-configured base station which is designed for operation in a large variety of standard frequency ranges. It makes extensive use of digital and DSP technology. Many operating parameters such as channel spacing, audio bandwidth and signalling are controlled by software.

This manual includes the information required for installing and operating the base station.

This section describes the different options available for:

- frequency bands
- RF output power
- power supply
- mechanical configurations
- product codes

For specifications, refer to the specifications manual or the area on the TaitWorld website reserved for TB7100 products.

1.1 Frequency Bands

The base station is available in the following frequency bands:

- 66 to 88MHz (A4)
- 136 to 174MHz (B1)
- 174 to 225MHz (C0)
- 216 to 266MHz (D1)
- 350 to 400MHz (G2)
- 400 to 470MHz (H5)
- 450 to 530MHz (H6)
- 450 to 520MHz (H7)

The RF band of the base station is implemented by the frequency band of the transmitter and receiver modules.

1.2 RF Output Power

The base station is available with 25 W and 50 W/40 W RF output power. The RF output power options are implemented by different transmitter and receiver modules.



The 25 W base station is available in the following frequency bands:

- A4
- B1
- C0
- D1
- H5
- H6



The 50 W/40 W base station is available in the following frequency bands:

- B1 (50 W)
- G2 (40 W)
- H5 (40 W)
- H7 (40 W)

1.3 Power Supply Options

The base station is available with or without an internal AC power supply.

All base stations have an external DC input power connector which is used as main power supply when no internal AC power supply is fitted.

When the internal AC power supply is fitted, the DC input can be used as a DC backup power option. In case of AC mains failure the base station will automatically and seamlessly switch to DC power input.



Note The base station will not charge the battery via the DC power connector when an internal AC power supply unit is fitted.

If no internal AC power supply is fitted, an external Tait T809-10-87xx power supply can be used to supply the DC voltage required.



Warning!! The internal AC power supply unit contains voltages that may be lethal. Refer to the ratings label on the rear of the base station. The internal AC power supply contains no user-serviceable parts.



Important Before connecting to the AC power connector, refer to the ratings label on the rear of the base station for its configured mains voltage.

1.4 Product Codes

This section describes the product codes used to identify products of the TB7100 base station product line.

The product codes of the TB7100 base station product line has the format:

TBBaabb-cde-ff

where:

- **aa** identifies the frequency band of the transmitter:
A4=66 to 88MHz, B1=136 to 174MHz, C0=174 to 225MHz,
D1=216 to 266 MHz, G2=350 to 400 MHz, H5=400 to 470MHz,
H6=450 to 530MHz, H7=450 to 520MHz
- **bb** identifies the frequency band of the receiver:
A4=66 to 88MHz, B1=136 to 174MHz, C0=174 to 225MHz,
D1=216 to 266 MHz, G2=350 to 400 MHz, H5=400 to 470MHz,
H6=450 to 530MHz, H7=450 to 520MHz
- **c** identifies the RF output power and digital architecture:
A=25 W, level-1 digital architecture
B=35 W to 50 W, level-1 digital architecture

- **d** identifies the power supply option:
 - 0=DC only
 - 1=internal AC power supply unit, factory preset to 115VAC
 - 2=internal AC power supply unit, factory preset to 230VAC
- **e** identifies the AC power cable:
 - 1 = Australia/New Zealand
 - 2 = United Kingdom
 - 3 = Europe
 - 4 = USA
- **ff** identifies base station options:
 - 00=no options

The block diagram illustrates the main inputs and outputs for power, RF and control signals, as well as the interconnection between modules:

- program data and audio from the PROG/MIC socket on the UI board to and from the transmitter and receiver modules
- audio and signalling from the SYSTEM connector to and from the transmitter and receiver modules
- RS-232 data from the serial data connector (IOIO) to and from the transmitter and receiver modules
- fan power and control from the SI board
- power distribution from the AC and DC power input connectors to the transmitter and receiver modules, and from the receiver module to the UI board.

The circuitry of the individual modules that make up the base station is described in more detail in the following sections.

Frequency Bands and Sub-bands

The circuitry of the transmitter and receiver modules is similar for all frequency bands and is therefore covered by a single description in this manual. Where the circuitry differs between bands, separate descriptions are provided for each frequency band. For more information on frequency bands, refer to the specifications manual.

RS-232 Signals

External data communications all occur directly between the connected computer (or other electrical equipment) and the transmitter and receiver modules over the RS-232 serial lines.

Fan Signals

The power and ground signals for the fans are routed from the SI board to the fans behind the front panel. These signals are electrically isolated from all other system signals to ensure fan noise is not transferred to other sensitive system components.

If there is a fault in the fan circuitry, the transmitter module is protected from overheating by its internal foldback circuitry.

Speaker Signal

Received audio is sent from the receiver module to the UI board. The volume is controlled by the volume potentiometer on the UI board. The audio signal is routed through the UI board to the speaker for monitoring purposes.

Power and Ground

The SI board provides power to the transmitter and receiver modules. The receiver modules provides power to the UI board.

2.1 Receiver Operation

Parts of Receiver Board

The main circuit parts of the receiver modules are:

- receiver
- frequency synthesizer
- CODEC (coder-decoder) and audio circuitry
- power supply
- interface circuitry

Software plays a prominent role in the functioning of the radio.

When describing the operation of the radio the software must be included with the above. This is considered further below.

These functional parts are described in detail below.

Figure 2.2 Receiver high-level block diagram

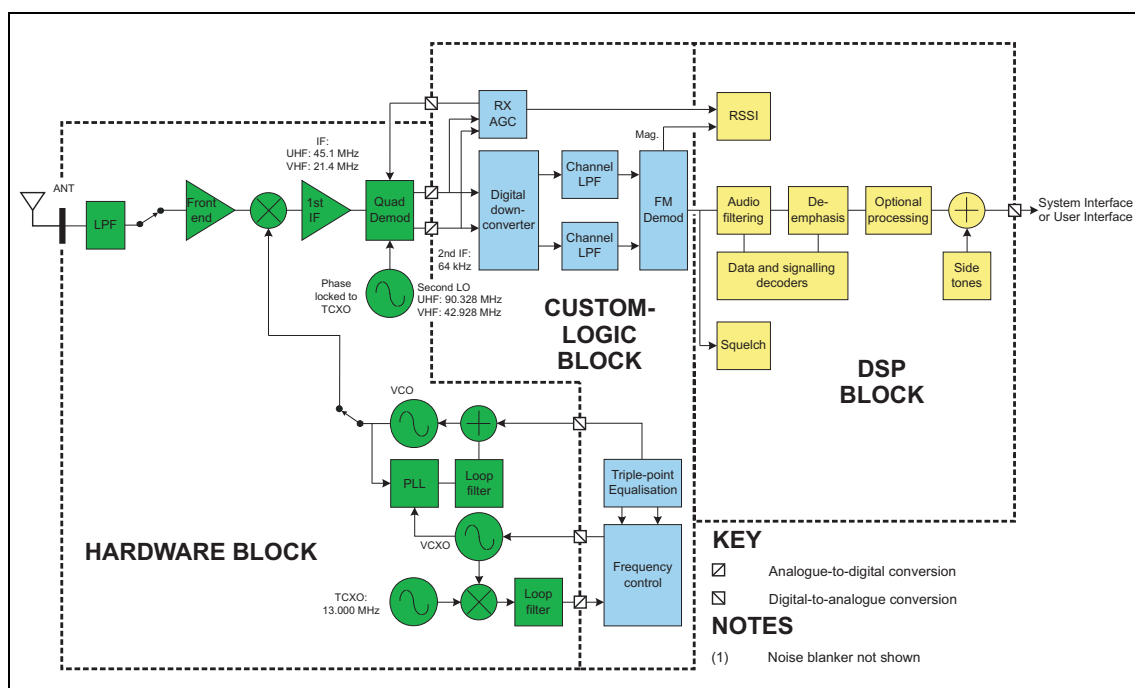

2.1.1 RF Hardware

Front End Circuitry and First IF

The front-end hardware amplifies and image filters the received RF spectrum, then down-converts the desired channel frequency to a first intermediate frequency IF1 of 45.1 MHz (UHF) or 21.4 MHz (VHF) where coarse channel filtering is performed. The first LO (local oscillator) signal is obtained from the frequency synthesizer and is injected on the low side of the desired channel frequency for all bands except A4. When receiving the modulation to the frequency synthesizer is muted. The output of the first IF (intermediate frequency) stage is then down-converted using an image-reject mixer to a low IF of 64 kHz.

Quadrature Demodulator	The LO for the image-reject mixer (quadrature demodulator) is synthesized and uses the TCXO (temperature-compensated crystal oscillator) as a reference. This ensures good centring of the IF filters and more consistent group-delay performance. The quadrature demodulator device has an internal frequency division of 2 so the second LO operates at $2 \times (IF1 + 64\text{kHz})$. The quadrature output from this mixer is fed to a pair of ADCs (analog-to-digital converters) with high dynamic range where it is oversampled at 256kHz and fed to the custom logic device.
Automatic Gain Control	The AGC (automatic gain control) is used to limit the maximum signal level applied to the image-reject mixer and ADCs in order to meet the requirements for intermodulation and selectivity performance. Hardware gain control is performed by a variable-gain amplifier within the quadrature demodulator device driven by a 10-bit DAC (digital-to-analog converter). Information about the signal level is obtained from the IQ (in-phase and quadrature) data output stream from the ADCs. The control loop is completed within custom logic. The AGC will begin to reduce gain when the combined signal power of the wanted signal and first adjacent channels is greater than about -70dBm . In the presence of a strong adjacent-channel signal it is therefore possible that the AGC may start acting when the wanted signal is well below -70dBm .

2.1.2 Digital Baseband Processing

Custom Logic	The remainder of the receiver processing up to demodulation is performed by custom logic. The digitised quadrature signal from the RF hardware is digitally down-converted to a zero IF, and channel filtering is performed at base-band. Different filter shapes are possible to accommodate the various channel spacings and data requirements. These filters provide the bulk of adjacent channel selectivity for narrow-band operation. The filters have linear phase response so that good group-delay performance for data is achieved. The filters also decimate the sample rate down to 48kHz. Custom logic also performs demodulation, which is multiplexed along with AGC and amplitude data, and fed via a single synchronous serial port to the DSP. The stream is demultiplexed and the demodulation data used as an input for further audio processing.
Noise Squelch	The noise squelch process resides in the DSP. The noise content above and adjacent to the voice band is measured and compared with a preset threshold. When a wanted signal is present, out-of-band noise content is reduced and, if below the preset threshold, is indicated as a valid wanted signal.
Received Signal Strength Indication	Received signal strength is measured by a process resident in the DSP. This process obtains its input from the demodulator (value of RF signal magnitude) and from the AGC (value of present gain). With these two inputs and a calibration factor, the RF signal strength at the antenna can be accurately calculated.

Calibration The following items within the receiver path are calibrated in the Factory:

- front-end tuning
- AGC
- noise squelch
- RSSI (received signal strength indication)

Information on the calibration of these items is given in the on-line help facility of the calibration application.

2.1.3 Audio Processing and Signalling

Audio Processing Raw demodulated data from the receiver is processed within the DSP. The sample rate at this point is 48kHz with signal bandwidth limited only by the IF filtering. Scaling (dependent on the bandwidth of the RF channel) is then applied to normalise the signal level for the remaining audio processing. The sample rate is decimated to 8kHz and bandpass audio filtering (0.3 to 3kHz) is applied. The base station takes the audio from the receiver mode at Tap R4 by default; this point has no de-emphasis. This tap point can be changed if required, for example, for trunking applications.

Data and Signalling Decoders The data and signalling decoders obtain their signals from various points within the audio processing chain. The point used depends on the bandwidth of the decoders and whether de-emphasis is required. Several decoders may be active simultaneously.

Side Tones Side tones are summed in at the end of the audio-processing chain. These are tones that provide some form of alert or give the user confidence an action has been performed. The confidence tones may be generated in the receiver. The side-tone level is a fixed proportion (in the order of -10dB) relative to full scale in the receive path. By default, all audible indicators are turned off.

CODEC The combined audio and side-tone signal is converted to analog form by a 16-bit DAC with integral anti-alias filtering. This is followed by a programmable-gain amplifier with a range of 45dB in 1.5dB steps. The amplifier performs muting. The DAC is part of the same CODEC device (AD6521).

Output to Speakers The output of the CODEC is fed to an audio power amplifier and to the UI board via a buffer amplifier. The output configuration of the audio power amplifier is balanced and drives an internal speaker. The power delivered to the speaker is limited by its impedance. The speaker has 16 Ω impedance.

2.2 Transmitter Operation

Parts of Transmitter Board

The main circuit parts of the transmitter board are:

- transmitter
- frequency synthesizer
- CODEC (coder-decoder) and audio circuitry
- power supply
- interface circuitry

Software plays a prominent role in the functioning of the board.

When describing the operation of the radio the software must be included with the above. This is considered further below.

These functional parts are described in detail below.

Figure 2.3 Transmitter high-level block diagram

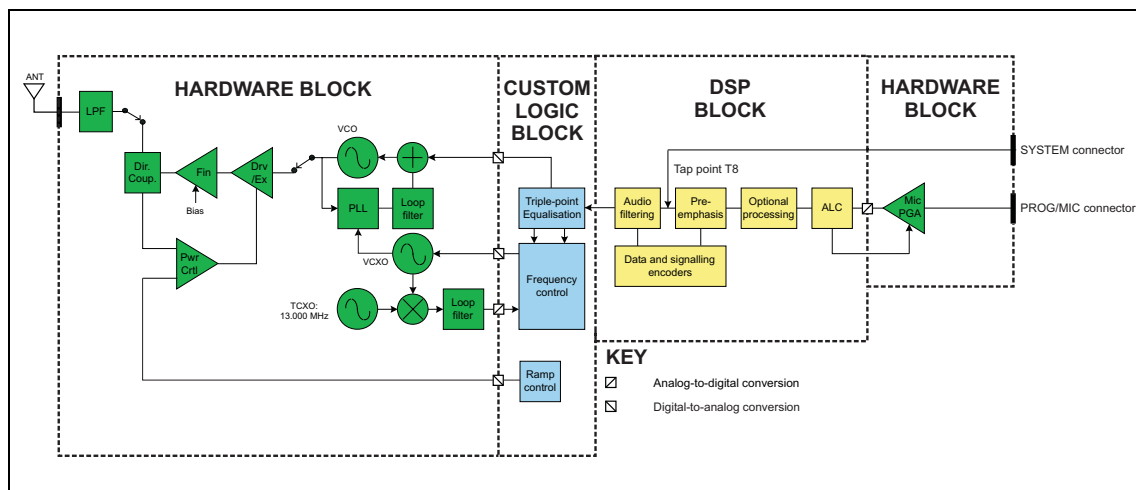

2.2.1 Audio Processing and Signalling

Microphone Input

The input to the transmitter path begins at either the SI board or the PROG/MIC connector of the UI board. Only electret-type microphones are supported. The audio input is then applied to tap point T8 on the transmitter board (the tap point is user-selectable).

Analog Processing of Microphone Signal

The CODEC (AD6521) performs microphone selection and amplification. The microphone amplifier consists of an amplifier with a fixed gain of 16 dB followed by a programmable-gain amplifier with 0 dB to 22 dB gain. The amplified microphone signal is converted to a digital stream by a 16-bit ADC with integral anti-alias filtering (0.1 to 3.2 kHz). The digital stream is transported to the DSP for further audio processing.

Automatic Level Control	The ALC (automatic level control) follows, and is used to effectively increase dynamic range by boosting the gain of the microphone pre-amplifier under quiet conditions and reducing the gain under noisy acoustic conditions. The ALC function resides in the DSP and controls the microphone programmable-gain amplifier in the CODEC. The ALC has a fast-attack (about 10ms) and slow-decay (up to 2s) characteristic. This characteristic ensures that the peak signal level is regulated near full scale to maximise dynamic range.
DSP Audio Processing	The output of the automatic level control provides the input to the DSP audio-processing chain at a sample rate of 8kHz. Optional processing such as encryption or companding is done first if applicable. Pre-emphasis, if required, is then applied. The pre-emphasised signal is hard limited to prevent over deviation, and filtered to remove high-frequency components. The sample rate is then interpolated up to 48kHz and scaled to be suitable for the frequency synthesizer.
Data and Signalling Encoders	The data and signalling encoders inject their signals into various points within the audio-processing chain. The injection point depends on the bandwidth of the encoders and whether pre-emphasis is required.

2.2.2 Frequency Synthesizer

Main Parts of Synthesizer	<p>The frequency synthesizer consists of two main parts:</p> <ul style="list-style-type: none"> ■ FCL (frequency control loop) ■ RF PLL (phase-locked loop) <p>The FCL and RF PLL are described briefly below. Note that patents are pending for several aspects of the synthesizer design.</p>
Frequency Control Loop	<p>The FCL consists of the following:</p> <ul style="list-style-type: none"> ■ TCXO ■ mixer ■ loop filter ■ VCXO (voltage-controlled crystal oscillator) ■ frequency control block <p>The FCL provides the reference frequency for the RF PLL. It generates a high-stability reference frequency that can be both modulated and offset in fine resolution steps.</p>

RF PLL

The RF PLL consists of the following:

- RF PLL device
- loop filter
- VCO (voltage-controlled oscillator)
- VCO output switch

The RF PLL has fast-locking capability but coarse frequency resolution. The above combination of control loops creates improved frequency generation and acquisition capabilities.

Operation of Control Loop

The RF PLL is a conventional integer-N design with frequency resolution of 25kHz. In transmit mode the loop locks to the transmit frequency.

Initially, the VCO generates an unregulated frequency in the required range. This is fed to the PLL device (ADF4111) and divided down by a programmed ratio to approximately 25kHz. The reference frequency input from the FCL is also divided down to approximately 25kHz. The phase of the two signals is compared and the error translated into a DC voltage by a programmable charge pump and dual-bandwidth loop filter. This DC signal is used to control the VCO frequency and reduce the initial error. The loop eventually settles to a point that minimises the phase error between divided-down reference and VCO frequencies. The net result is that the loop locks to a programmed multiple of the reference frequency.

The FCL generates an output of 13.012 ± 0.004 MHz. Initially a VCXO produces a quasi-regulated frequency in the required range. The VCXO output is fed to a mixer where it is mixed with the 13.000 MHz TCXO frequency. The mixer, after low-pass filtering to remove unwanted products, produces a nominal frequency of 12kHz. This is converted to digital form and transported to the frequency-control block in custom logic.

The frequency-control block compares the mixer output frequency with a reference generated by the digital clock and creates a DC error signal. A programmed offset is also added. This error signal is converted to analog form and used to control the VCXO frequency and reduce the initial error. Once settled, the loop locks to the TCXO frequency with a programmed offset frequency. The FCL output therefore acquires the TCXO's frequency stability.

Modulation

The full bandwidth modulation signal is obtained from the DSP in digital form at a sample rate of 48kHz. In traditional dual-point modulation systems the modulation is applied, in analog form, to both the frequency reference and the VCO in the RF PLL, combining to produce a flat modulation response down to DC. Reference modulation is usually applied directly to the TCXO.

In the system employed in the transmitter board, the frequency reference is generated by the FCL, which itself requires dual-point modulation injection to allow modulation down to DC. With another modulation point required in the RF PLL, this system therefore requires triple-point modulation. The modulation signals applied to the FCL are in digital form, whereas for the RF PLL (VCO) the modulation signal is applied in analog form. The modulation cross-over points occur at approximately 30 and 300Hz as determined by the closed loop bandwidths of the FCL and RF PLL respectively.

Frequency Generation

The RF PLL has a frequency resolution of 25kHz. Higher resolution cannot be achieved owing to acquisition-time requirements and so for any given frequency the error could be as high as ± 12.5 kHz. This error is corrected by altering the reference frequency to the RF PLL. The FCL supplies the reference frequency and is able to adjust it up to ± 300 ppm with better than 0.1ppm resolution (equivalent to better than 50Hz resolution at the RF frequency).

Fast Frequency Settling

Both the FCL and RF PLL employ frequency-acquisition speed-up techniques to achieve fast frequency settling. The frequency-acquisition process of the FCL and RF PLL is able to occur concurrently with minimal loop interaction owing to the very large difference in frequency step size between the loops.

Frequency Acquisition of RF PLL

In the RF PLL the loop bandwidth is initially set high by increasing the charge pump current and reducing time constants in the loop filter. As a result settling to within 1kHz of the final value occurs in under 4ms. In order to meet noise performance requirements the loop parameters are then switched to reduce the loop bandwidth. There is a small frequency kick as the loop bandwidth is reduced. Total settling time is under 4.5ms.

Frequency Acquisition of FCL

The FCL utilises self-calibration techniques that enable it to rapidly settle close to the final value while the loop is open. The loop is then closed and settling to the final value occurs with an associated reduction in noise. The total settling time is typically less than 4ms.

Calibration

The following items are calibrated in the frequency synthesizer:

- nominal frequency
- KVCO
- KVCXO
- VCO deviation

Calibration of the nominal frequency is achieved by adding a fixed offset to the FCL nominal frequency; the TCXO frequency itself is not adjusted. The items KVCO and KVCXO are the control sensitivities of the RF VCO (in MHz/V) and VCXO (in kHz/V) respectively. The latter has temperature compensation.

2.2.3 RF Power Amplifier

RF Power Amplifier and Switching (50W/40W Version)



The RF power amplifier and exciter of the 50W/40W radio is a five-stage line-up with approximately 40 dB of power gain. The output of the frequency synthesizer is first buffered to reduce kick during power ramping. The buffer output goes to a discrete exciter that produces approximately 300 to 400mW output. This is followed by an LDMOS driver producing up to 8 W output that is power-controlled. The final stage consists of two parallel LDMOS devices producing enough power to provide 40 to 50 W at the RF connector.

RF Power Amplifier and Switching (25W Version)



The RF power amplifier of the 25 W version is a four-stage line-up with approximately 37 dB of power gain. The output of the frequency synthesizer is first buffered to reduce kick during power ramping. The buffer output goes to a broad-band exciter IC that produces approximately 200mW output. This is followed by an LDMOS driver producing up to 2 W output that is power-controlled. The final stage consists of two parallel LDMOS devices producing enough power to provide 25 W at the RF connector.

Output of RF Power Amplifier

The output of the RF PA passes through a dual-directional coupler, used for power control and monitoring. Finally, the output is low-pass-filtered to bring harmonic levels within specification.

Power Control

The steady-state power output of the transmitter is regulated using a hardware control loop. The forward power output from the RF PA is sensed by the directional coupler and fed back to the power control loop. The PA output power is controlled by varying the driver gate bias voltage that has a calibrated maximum limit to prevent overdrive. The power control signal is supplied by a 13-bit DAC driven by custom logic.

Ramping

Power ramp-up consists of two stages:

- bias
- power ramping

The timing between these two stages is critical to achieving the correct overall wave shape in order to meet the specification for transient ACP (adjacent channel power). A typical ramping waveform is shown in [Figure 2.4](#).

Figure 2.4 Typical ramping waveforms

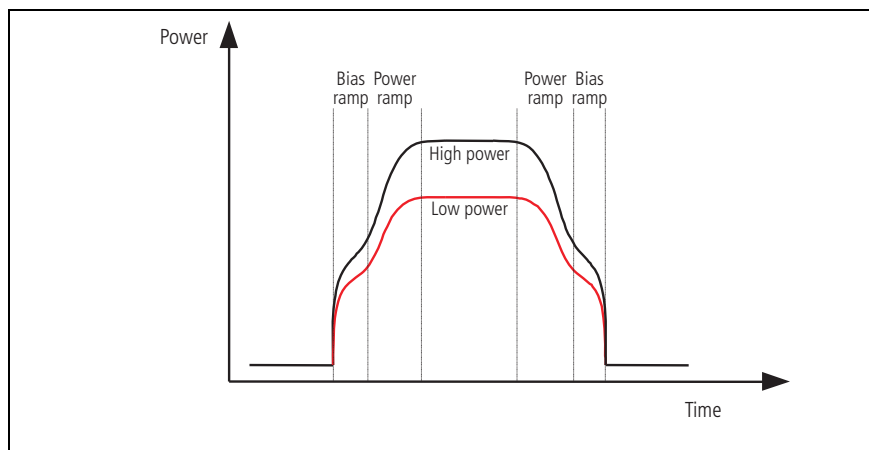

Bias Ramp-up



The steady-state final-stage bias level is supplied by an 8-bit DAC programmed prior to ramp-up but held to zero by a switch on the DAC output under the control of a TX INHIBIT signal. Bias ramp-up begins upon release by the TX INHIBIT signal with the ramping shape being determined by a low-pass filter. Owing to power leakage through the PA chain, ramping the bias takes the PA output power from less than -20 dBm for the 50 W/40 W version or -10 dBm for the 25 W version to approximately 25 dB below steady-state power.

Power Ramp-up

The power ramp signal is supplied by a 13-bit DAC that is controlled by custom logic. The ramp is generated using a look-up table in custom logic memory that is played back at the correct rate to the DAC to produce the desired waveform. The ramp-up and ramp-down waveforms are produced by playing back the look-up table in forward and reverse order respectively. For a given power level the look-up table values are scaled by a steady-state power constant so that the ramp waveform shape remains the same for all power levels.

2.3 User Interface Operation

This section describes the programming/microphone connector and the controls of the user interface, and the function of the UI board.

Figure 2.5 shows the controls and indicators of the user interface.

Programming/ Microphone Connector

The PROG/MIC connector can be used to connect a handset or a programming cable.

Figure 2.5 User interface

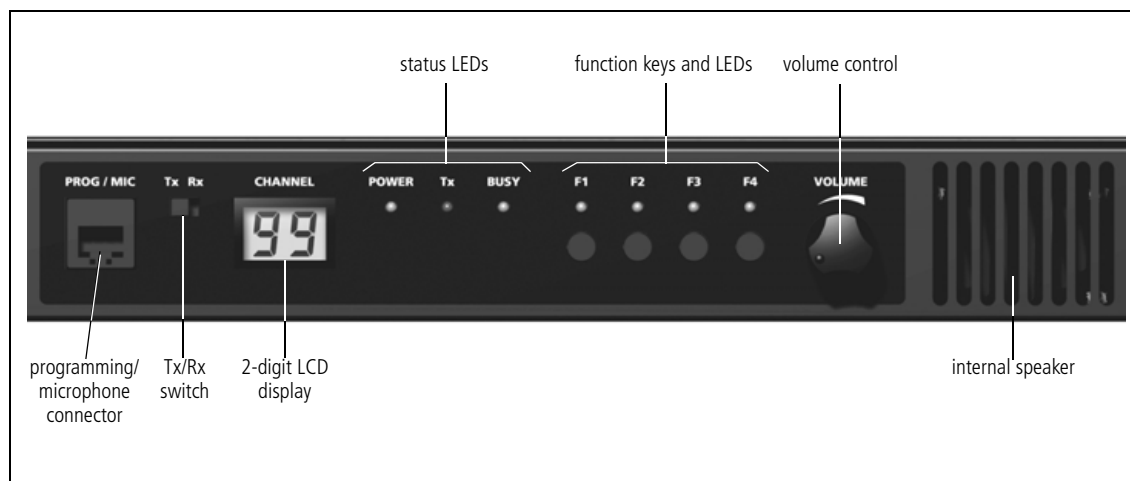

TX/RX Switch

The TX/RX switch changes the LCD display to show either the transmitter or the receiver channel. The TX/RX switch also determines which board will be programmed by the programming or calibration applications.

The TB7100 programming application is a program on a PC that is connected to the base station via the PROG/MIC connector. The TB7100 programming application enables the user to program the base station with the required channels and subaudible signalling settings. The transmitter and receiver modules are programmed individually according to the setting of the TX/RX switch.

The calibration application is a program on a PC that is connected to the base station via the PROG/MIC connector. The transmitter and receiver modules are designed to be totally electronically tuned. No physical tuning is required, as all tuning is done by electronic trimming. The calibration application can assist in the tuning of:

- AD6521 CODEC voltage reference
- TCXO frequency
- receiver front end
- transmitter driver and final gate bias limit
- transmitter power control
- deviation and squelch.

Function Keys

Pressing the function keys will activate the functions assigned using the TB7100 programming application. Function keys may have functions assigned to both short and long key presses. A short key press is less than one second, and a long key press is more than one second.



Note The UI board can be configured to use the F1 and F2 keys to increment and decrement the channel. If the UI board is configured in this way, F1 and F2 can no longer be programmed using the TB7100 programming application.

Volume Control and Internal Speaker

Rotate the volume control potentiometer clockwise to increase the speaker volume and counterclockwise to decrease the volume. By default, the base station is programmed not to generate any audible indicators.

UI Board

The UI board is connected to the receiver and transmitter modules via separate 18-way ribbon cables. The internal speaker is connected to the UI board via a cable with a mating connector for easy disconnection. If an internal AC Power supply is fitted, a fan power signal is routed from the fan power board to the fan via the UI board. For more information on the connectors and their signals, refer to [“UI Board Connectors” on page 55](#).

[Figure 2.6 on page 26](#) shows a block diagram of the UI board.

The UI board does not include a microprocessor. A synchronous bi-directional serial interface provides communication of key status, LCD and LED-indicator data between the transmitter/receiver modules and the UI board. The serial data is converted to or from a parallel form by a number of shift registers for the function keys and indicators. For the LCD, the serial data is fed to a driver IC that converts the serial data to a form suitable for the LCD. The keys are scanned and the LCD and LED indicators updated approximately every 50ms. The TX/RX switch controls what is displayed on the LCD and also whether the transmitter module or the receiver module will be programmed.

Figure 2.6 UI board block diagram

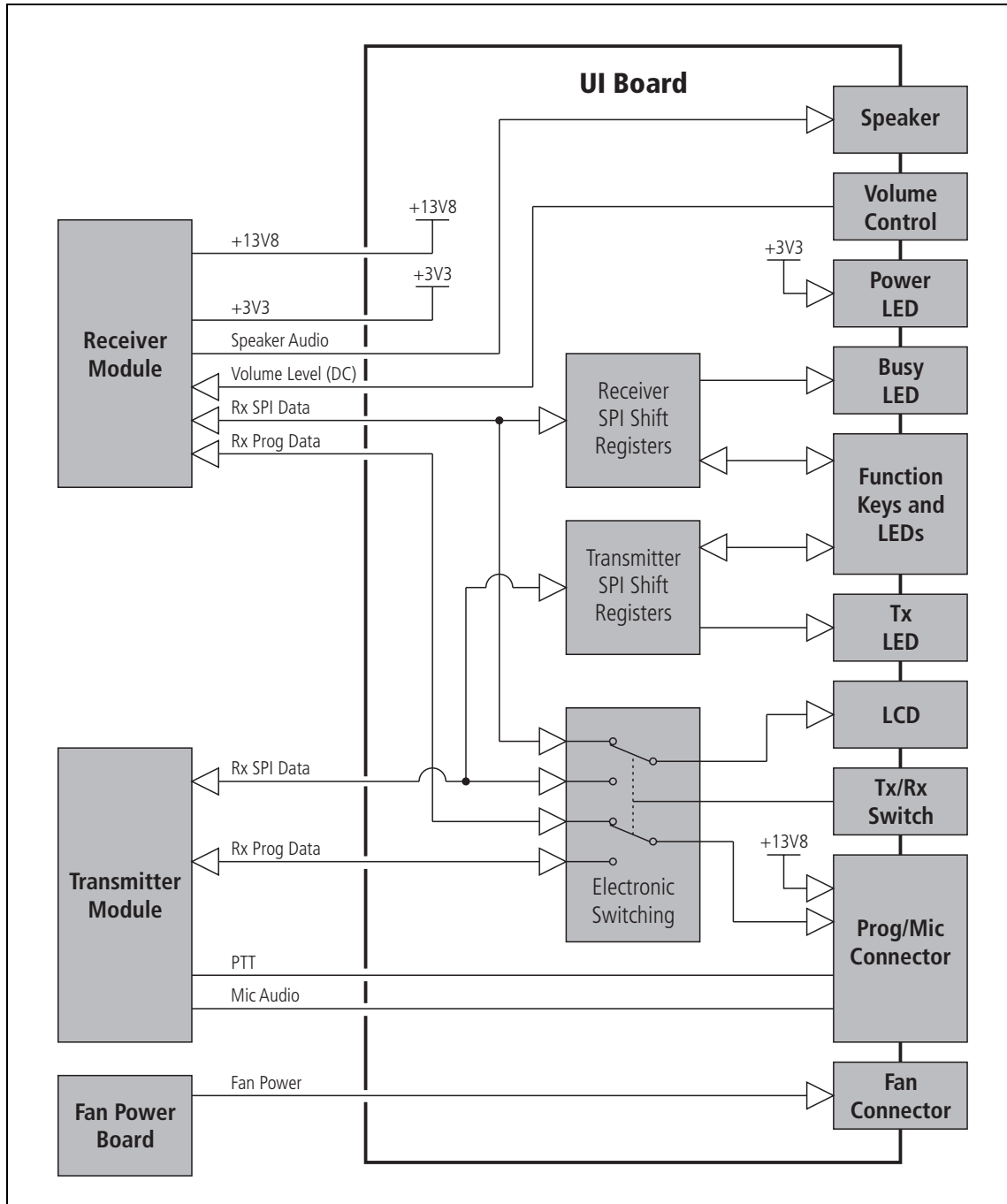

2.4 System Interface Operation

This section describes the functioning of the system interface. The system interface provides:

- internal power distribution
- internal AC/external DC switching
- serial data connection (THSD or FFSK)
- fan control
- general purpose IO
- receiver audio processing
- transmitter audio processing
- opto-isolated keying
- relay output
- relay driver
- received signal strength indication (RSSI)
- receiver gate output
- receiver inhibit input
- 13.8VDC (1.5A) output
- tone on idle (TOI).

These functional parts are described in detail below.

Figure 2.7 SI board block diagram

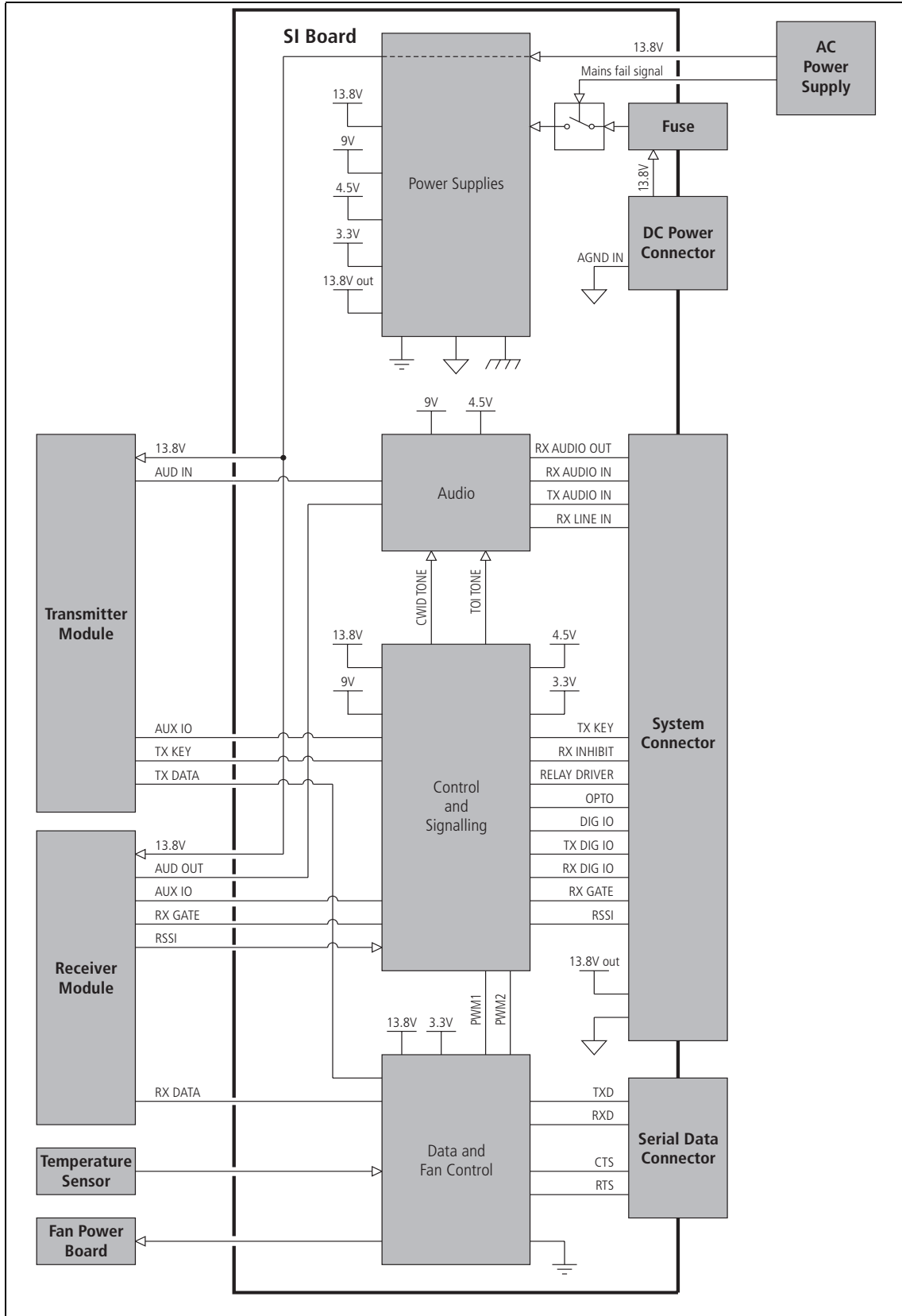

2.4.1 Internal Power Distribution

This section details how the input power feed is distributed throughout the base station to power its various sub-systems. Refer to [Figure 2.8](#) for more information.

Figure 2.8 Power distribution

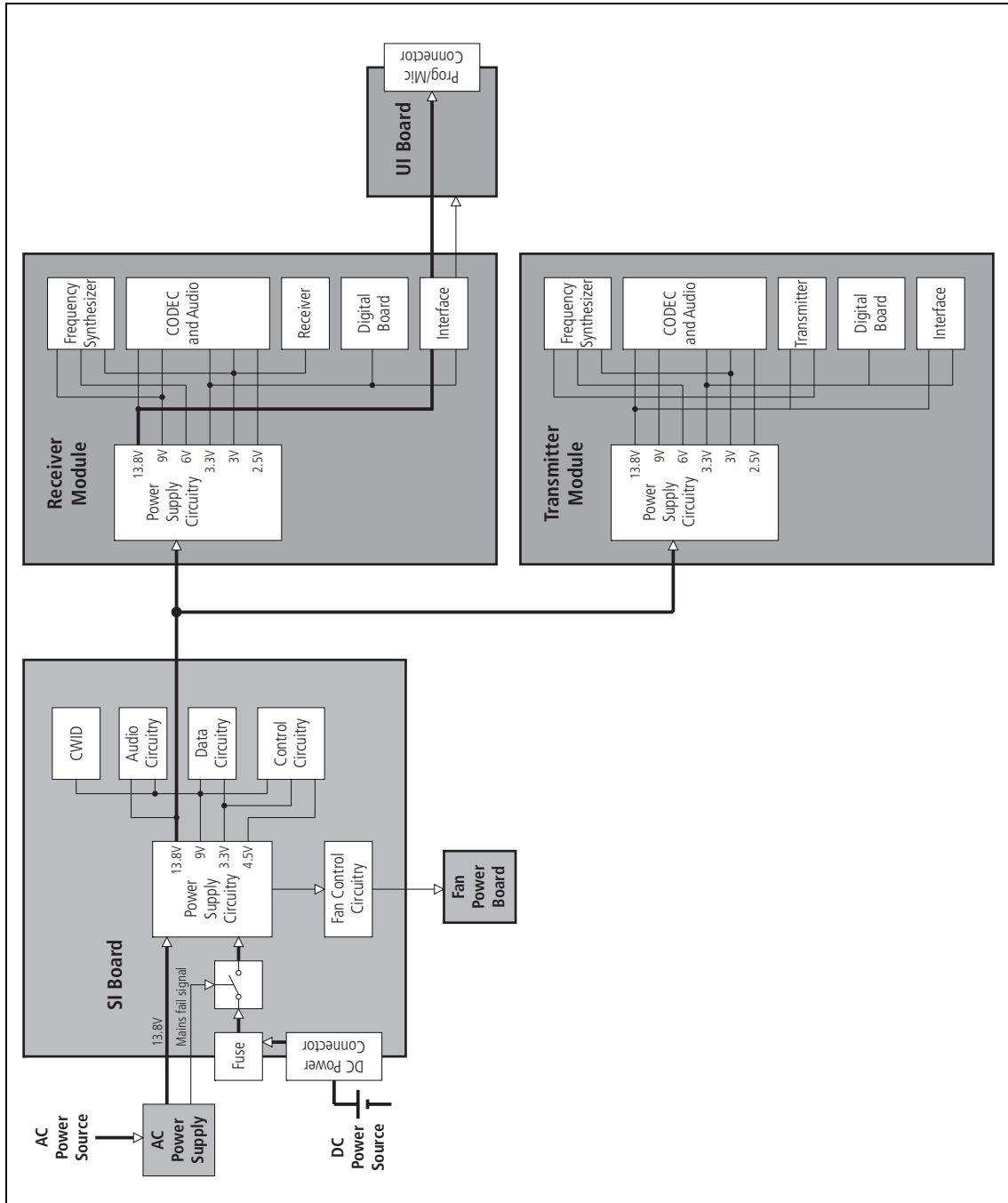

13.8V DC

This is from either the DC input on the rear of the base station, or from an optional internal AC power supply unit. When AC mains is present, power will not be drawn from the DC input. The DC power input of the base station is protected by a rear panel fuse. The 13.8V is distributed directly to

the receiver and transmitter boards and to the 13.8VDC output on the SYSTEM connector, rated at 1.5A. The 13.8VDC is also used to power the fans, via control circuitry.



Note The UI board obtains 13.8V and 3.3V from the receiver module and outputs 13V8_SW to the PROG/MIC connector.

3.3V, 4.5V, 9V, 13.8V The other voltages derived on the SI board are used only on the SI board.

2.4.2 Serial Data

THSD Tait High Speed Data (THSD) is a proprietary protocol of Tait Electronics Limited that can be used with the base station. This allows the base station configured in either data repeater or data modem modes to pass data speeds up to 12kbps on a narrow-band channel and 19.2kbps on a wide-band channel. 1200-baud Fast Frequency Shift Keyed (FFSK) data is also available.

To prevent multiple simultaneous THSD transmission collisions, the Service Kit can be used to enable the THSD anti-collision feature. With this feature enabled, as soon as the receiver detects data being received at the base station, the transmitter will be keyed up to transmit dummy data packets, inhibiting other radios in the field from transmitting.

2.4.3 General Purpose IO

The transmitter and receiver boards can be programmed to act upon signals from the SI board and also outputs signals for certain conditions. These settings are discussed in [“Preparation for Operation” on page 59](#).

2.4.4 Receiver Audio Processing

The SI board provides an external 600 Ω balanced 4-wire line for connecting 4-wire circuits of which two are used by the receiver for receive audio.

The SI board provides an unbalanced audio output for connecting to other devices. Output levels can be set via the rear panel.

2.4.5 Tone On Idle

The tone-on-idle (TOI) frequency is generated by the SI board and fed directly to the receiver line out. It is enabled using links on the SI board. These settings are discussed in [“Preparation for Operation” on page 59](#). If enabled, the output of the TOI is switched by the receiver gate.

2.4.6 Transmitter Audio Processing

The SI board provides an external 600Ω balanced 4-wire line for connecting 4-wire circuits of which two are used by the transmitter for transmit audio.

The SI board provides an unbalanced audio input and output for connecting to other devices.

2.4.7 Opto-Isolated Keying

External keying of the base station can be achieved using the current regulated optically isolated keying connections.

2.4.8 Rx Relay

The SI board can provide a relay output with a load voltage of 350V or load current of 120mA continuous.

This option is configurable and is discussed in [“Relay Polarity” on page 105](#).

2.4.9 Relay Driver

Tait application note TN-1088C-AN describes how to connect a coaxial relay (T800-09-xxxx) to a TB7100 (fitted with SI boards 220-02077-04 or later) operating as a base station.

2.4.10 Fan Control

There are three modes of operation for the fans. The modes are:

- on continuous
- on when transmitting
- on at a pre-defined temperature.

The modes of operation are selected by links on the SI board. These settings are discussed in [“Preparation for Operation” on page 59](#).

2.4.11 RSSI

A received signal strength indication (RSSI) voltage is developed by the receiver module and applied directly to the SI board rear panel.

2.4.12 Receiver Gate

The receiver gate signal is used by the SI board to control TOI and a relay output. The receiver gate output on the SYSTEM connector can be used for external equipment such as TaitNet trunking controllers.

2.4.13 Receiver Inhibit

The receiver inhibit input on the SYSTEM connector is used to control the receiver gate signal. This may be used in linking applications to prevent unwanted receiver audio signals from appearing at the SI board output connector.

2.5 Fan Operation

The cooling fans are mounted behind the front panel. All fans in the chassis must be of the same type.

Dissipation of Heat Heat needs to be dissipated from a number of components within the internal AC power supply unit, transmitter and receiver modules, including the following:

- 9V regulator
- RF PA
- driver for RF PA
- audio PA

The mechanisms by which the heat is conducted away in each case are described below.

Dissipation of Heat from Transmitter The transmitter board is mounted directly onto a heatsink through which the forced air from the fans is ducted.

Dissipation of Heat from Regulator and Audio PA Heat from the audio PA and 9V regulator on the receiver board is conducted away by a small aluminium heatsink and mounting boss. The heatsink and boss contact the underside of the board where the components are mounted and thermal paste ensures a good thermal transfer between the two surfaces.

Dissipation of Heat from RF PAs and Driver Heat from the RF PAs and driver is conducted to the heatsink through a copper separator plate. The copper plate is fixed to the underside of the board and the components soldered directly to it. The copper plate is mounted directly to the main heatsink boss and a coating of thermal paste ensures good thermal transfer between these two surfaces.

Dissipation of Heat from Internal AC Power Supply Unit Air is forced round major components within the internal AC power supply unit to keep them cool. Some air is passed through a small heatsink to keep the current-carrying semiconductor devices cool.

3 Installation

This section describes how to install the base station in a standard 19-inch rack or cabinet. It also provides some general information on safety precautions and site requirements. We recommend that you read the entire section before beginning the installation.

3.1 Personal Safety

3.1.1 Lethal Voltages

The base station may be fitted with an internal AC power supply unit. If an internal AC power supply unit is fitted, a standard ICE AC power connector is fitted in the rear panel of the base station (refer to “[AC Power Connection](#)” on page 46).



Warning!! The internal AC power supply unit contains voltages that may be lethal. Refer to the ratings label on the rear of the base station. The internal AC power supply contains no user-serviceable parts.



Important Before connecting to the AC power connector, refer to the ratings label on the rear of the base station for its configured mains voltage.

The base station must be installed so that the rear of the base station is located in a service access area. The plug of the AC power supply cord is intended as the disconnect device. Therefore, the socket-outlet must be installed near the equipment and must be readily accessible.

Ensure that all power sources (AC and DC) are disconnected before opening the base station.

3.1.2 AC Power Connection

English (en)	The PMU must be connected to a grounded mains socket-outlet.
Norsk (no)	Apparatet må tilkoples jordet stikkontakt.
Suomi (fi)	Laite on liitettävä suojamaadoitus-koskettimilla varustettuun pistorasiaan.
Svenska (sv)	Apparaten skall anslutas till jordat uttag.

3.1.3 Explosive Environments



Warning!! Do not operate base station equipment near electrical blasting caps or in an explosive atmosphere. Operating the equipment in these environments is a definite safety hazard.

3.1.4 Proximity to RF Transmissions

Do not operate the transmitter when someone is standing within 90 cm (3ft) of the antenna. Do not operate the transmitter unless you have checked that all RF connectors are secure.

3.1.5 High Temperatures

Take care when handling a base station which has been operating recently. Under extreme operating conditions (+60°C [+140°F] ambient air temperature) or high duty cycles the external surfaces of the base station can reach temperatures of up to +80°C (+176°F).

3.1.6 LED Safety (EN60825-1)

This equipment contains LEDs which are considered a
CLASS 1 LED PRODUCT.

3.2 Equipment Safety

3.2.1 ESD Precautions



Important

This equipment contains devices which are susceptible to damage from static charges. You must handle these devices carefully and according to the procedures described in the manufacturers' data books.

We recommend you purchase an antistatic bench kit from a reputable manufacturer and install and test it according to the manufacturer's instructions. [Figure 3.1](#) shows a typical antistatic bench set-up.

You can obtain further information on antistatic precautions and the dangers of electrostatic discharge (ESD) from standards such as ANSI/ESD S20.20-1999 or BS EN 100015-4 1994.

Figure 3.1 Typical antistatic bench set-up

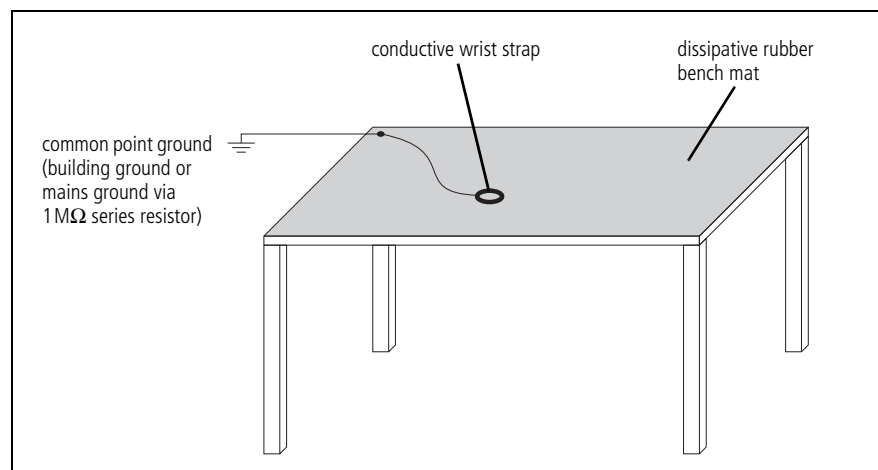

3.2.2 Antenna Load

The base station has been designed to operate safely under a wide range of antenna loading conditions. However, damage will occur if the load is removed while the base station is transmitting. Transmitting into a low VSWR will maximise the power delivered to the antenna.

3.2.3 Equipment Grounding

To ensure safe operation, the base station must be correctly grounded as described in these installation instructions.

3.2.4 Installation and Servicing Personnel

The base station should be installed and serviced only by qualified personnel.

3.3 Regulatory Information

3.3.1 Distress Frequencies

The 406 to 406.1MHz frequency range is reserved worldwide for use by Distress Beacons. Do **not** program transmitters to operate in this frequency range.

3.3.2 FCC Compliance¹

This device complies with part 15 of the FCC Rules. Operation is subject to the condition that this device does not cause harmful interference.

3.3.3 Unauthorised Modifications

Any modifications you make to this equipment which are not authorised by Tait Electronics Ltd. may invalidate your compliance authority's approval to operate the equipment.

3.3.4 Health, Safety and Electromagnetic Compatibility in Europe

In the European Community, radio and telecommunications equipment is regulated by Directive 1999/5/EC, also known as the Radio and Telecommunications Terminal Equipment (R&TTE) directive. The requirements of this directive include protection of health and safety of users, as well as electromagnetic compatibility.

Intended Purpose of Product

This product is an FM radio transceiver. Its intended purpose is for radio communication in Private Mobile Radio (PMR) services or Public Access Mobile Radio (PAMR) services, to be used in all member states of the European Union (EU) and states within the European Economic Area (EEA).



Important

This product can be programmed to transmit on frequencies that are not harmonised throughout the EU/EEA, and will require a licence to operate in each member state. All

-
1. Refer to the specifications manual for more information on the compliance standards to which the base station has been tested and approved.

license requirements must be observed. Limitations may apply to transmitter power, operating frequency, channel spacing, and emission.

Declaration of Conformity

Brief Declarations of Conformity appear [on page 121](#). You can download the formal Declaration of Conformity from <http://eudocs.taitworld.com/>. You can also obtain a signed and dated paper copy of the Declaration of Conformity from Tait Europe Ltd.

For Customers in Luxembourg

This equipment must not be operated as a data repeater in Luxembourg unless it is used in conjunction with an approved Channel Access Controller that meets the requirements of ETSI standard EN 300 471.

3.4 Environmental Conditions

3.4.1 Operating Temperature Range

The operating temperature range is -30°C to $+60^{\circ}\text{C}$ (-22°F to $+140^{\circ}\text{F}$) ambient temperature for the 25 W base station and -30°C to $+50^{\circ}\text{C}$ (-22°F to $+122^{\circ}\text{F}$) ambient temperature for the 50 W and 40 W base stations. Ambient temperature is defined as the temperature of the air at the intake to the cooling fans.

3.4.2 Humidity

The humidity should not exceed 95% relative humidity through the specified operating temperature range.

3.4.3 Dust and Dirt

For uncontrolled environments, the level of airborne particulates must not exceed $100\mu\text{g}/\text{m}^3$.

3.5 Grounding and Lightning Protection

3.5.1 Electrical Ground

A threaded grounding connector is provided on the rear of the tray for connection to the site ground point (for more details refer to [“Connections” on page 45](#)).

3.5.2 Lightning Ground

It is extremely important for the security of the site and its equipment that you take adequate precautions against lightning strike. Because it is outside the scope of this manual to provide comprehensive information on this subject, we recommend that you conform to your country's standards organisation or regulatory body.

3.6 Recommended Tools

It is beyond the scope of this manual to list every tool that an installation technician should carry. However, the following tools are specifically required for installing the base station:

- Philips #2 tip screwdriver used to connect the DC power cables to the DC power terminals
- Pozidriv PZ3 screwdriver for the M6 screws used to secure the tray to the cabinet in Tait factory-assembled systems
- Torx T10 screwdriver for the M3 pan head screws with captured shake-proof washer and flat washer used to secure the modules in the tray
- Torx T10 screwdriver for the M3 countersunk screws used to secure the cover and the heatsink channels to the tray
- Pozidriv PZ1 screwdriver for the M3 pan head self-tapping screws used to secure the fans.

You can also obtain the TBA0ST2 tool kit from your nearest Tait dealer or Customer Service Organisation. It contains the basic tools needed to install, tune and service the base station.

3.7 Ventilation

Always ensure there is adequate ventilation around the base station. **Do not** operate at high duty cycles in a sealed cabinet. You **must** keep the ambient temperature within the specified range, and we **strongly** recommend you ensure that the cooling airflow is not restricted.



Important

The cooling fans are mounted behind the front panel. To ensure adequate airflow through the base station, do not operate it for more than a few minutes with the fans disconnected (e.g. for servicing purposes).

Cabinet and Rack Ventilation

Refer to [Figure 3.2 on page 39](#).

Adequate cooling airflow is critical to the performance of the base station. The cooling airflow for the base station enters through the front panel and exits at the rear of the tray. For optimum thermal performance, the heated

Figure 3.2 Typical cabinet ventilation requirements

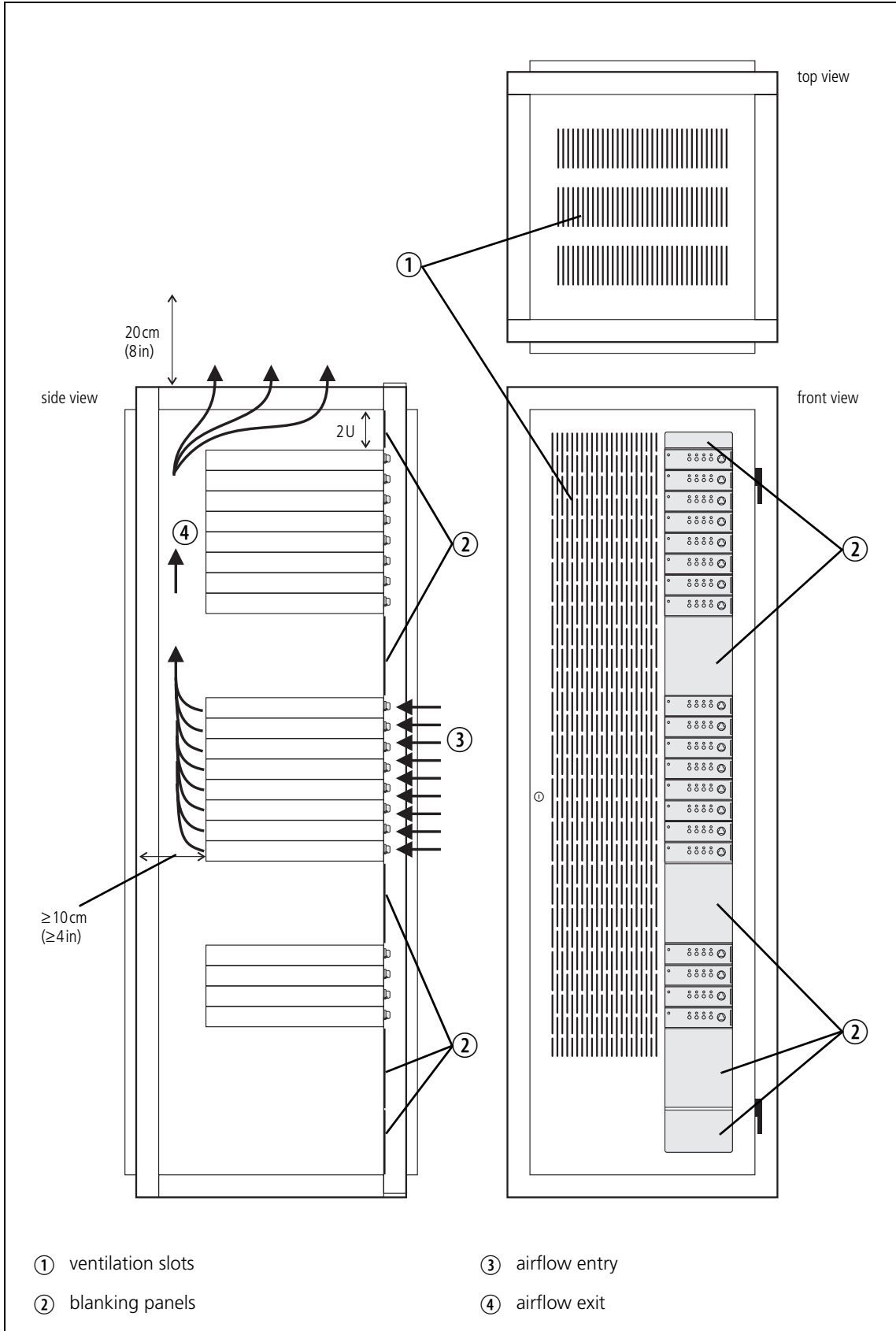

air that has passed through a base station must not be allowed to re-enter the air intakes on the front panel.

Each base station requires an unobstructed airflow of 18m³/h (11 cfm).

To allow enough cooling airflow through a cabinet mounted base station we recommend the following:

- a distance of 5 cm minimum clearance to any obstruction to the front of the tray.
- an open area of at least 50cm² (8sq.in.) per tray of ventilation slots or louvres in front of the air intakes for the fans for each tray; for example ten 6×85mm (0.25×3.3in.) slots will allow the recommended airflow.
- a distance of 10cm minimum clearance to any obstruction to the rear of the tray.
- an open area of at least 50cm² (8sq.in.) per tray of ventilation slots or louvres in the top of the cabinet, or to the rear of each tray.
- a 2U gap at the top of the cabinet.



Note The ventilation opening must be unrestricted. If the slots or holes are covered with a filter, mesh or grille, the open area must be increased to allow the same airflow as an unrestricted opening.

The maximum ambient temperature entering the cabinet must not exceed the maximum temperature specified for the base station.

If the base station is installed in a rack or cabinet with other equipment with different ventilation requirements, we recommend that the base station be positioned below this equipment.

Auxiliary Extractor Fans

If multiple base stations are fitted in a cabinet, auxiliary extractor fans may be required to ensure adequate cooling. If fitted they should be capable of extracting 18m³/h (11 cfm) per base station in the cabinet.

If you have any other configuration, the performance of your system will depend on how closely you comply with the base station airflow requirements described above.

3.8 Installing the Base Station

3.8.1 Unpacking the Equipment

Unpacking the Base Station

The base station is packed in a strong corrugated cardboard carton with top and bottom foam cushions.

1. Cut the tape securing the flaps at the top of the carton and fold them flat against the sides.

2. Rotate the carton carefully onto its side and then onto its top, ensuring that none of the flaps is trapped underneath.
3. Slide the carton upwards over the foam cushions and lift it away. Remove the cushion from the bottom of the base station.
4. Lift the base station clear of the remaining cushion.

Disposal of Packaging

If you do not need to keep the packaging, we recommend that you recycle it according to your local recycling methods. The foam cushions are CFC- and HCFC-free and may be burnt in a suitable waste-to-energy combustion facility, or compacted in landfill.

3.8.2 Power Supply Options

The base station is available with or without an internal AC power supply unit.

All base stations have an external DC input power connector which is used as main power supply when no internal AC power supply unit is fitted.

When the internal AC power supply unit is fitted, the DC input can be used as a DC backup power option. In case of AC mains failure the base station will automatically and seamlessly switch to DC power input.

If no internal AC power supply unit is fitted, an external Tait T809-10-87xx power supply can be used to supply the DC voltage required.

3.8.3 Mounting the Base Station

1. Fit the base station into the cabinet or rack and secure it firmly with an M6 (or 0.25in if you are using imperial fittings) screw, flat and spring washer in each of the four main mounting holes ①, as shown in Figure 3.3 on page 42.
2. The base station can be wall-mounted by rotating the front mounting brackets and fitting the optional rear brackets (TBBA03-01). When the base station is wall-mounted ensure the airflow is from bottom to top (front panel mounted down) or side to side.
3. For transport or in installations subject to vibration, the base station should be supported at the rear using a transit bracket (Tait recommends to use the TB7100 transit bracket, Tait part number TBBA03-04).

Figure 3.3 Base station mounting points (configuration with AC power supply unit shown)

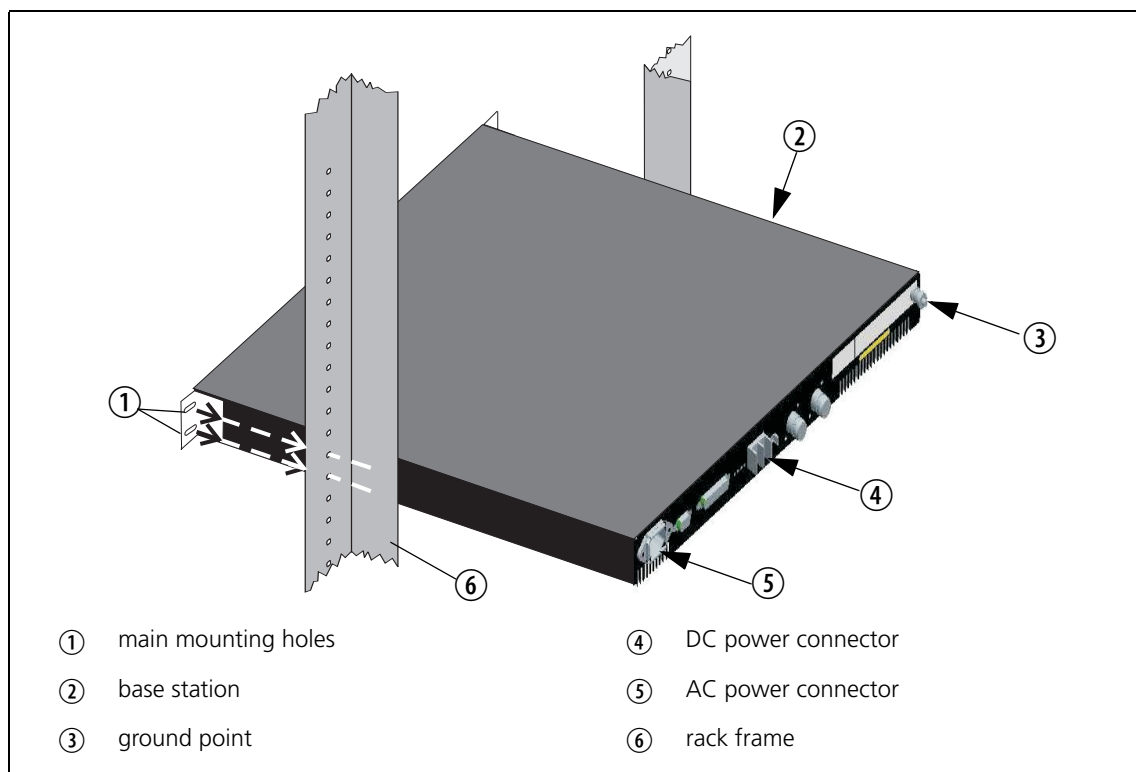

3.8.4 Cabling

We recommend that you route all cables to and from the base station along the side of the cabinet so the cooling airflow is not restricted.

Cables should be well supported so that the connectors or terminals on the base station and on the ends of the cables do not have to support the full weight of the cables.

Cables must be routed so that they do not restrict the air outlets at the rear of the base station.

3.8.5 Accessories

The base station can use the following accessories:

- T809-10-87xx power supply
- TBBA03-01 wall mounting kit
- TBBA03-02 duplexer kit
(mechanical configuration without provision for internal AC power supply unit)
- TBBA03-03 duplexer kit
(mechanical configuration with provision for internal AC power supply unit)
- TBBA03-04 TB7100 transit bracket kit
- TBBA03-05 antenna relay kit
- TBBA04-01 cable assembly to connect TB7100 to TBA0M0x Tone Remote
- TBBA04-02 cable assembly to connect TB7100 to CMM card
- TMAA02-01 fist microphone

4 Connections

Overview This section gives an overview of looms and cables, and describes the specifications and pinouts of the external and internal connectors.

Figure 4.1 provides an overview of the connections.

Figure 4.1 Connectors, looms and cables

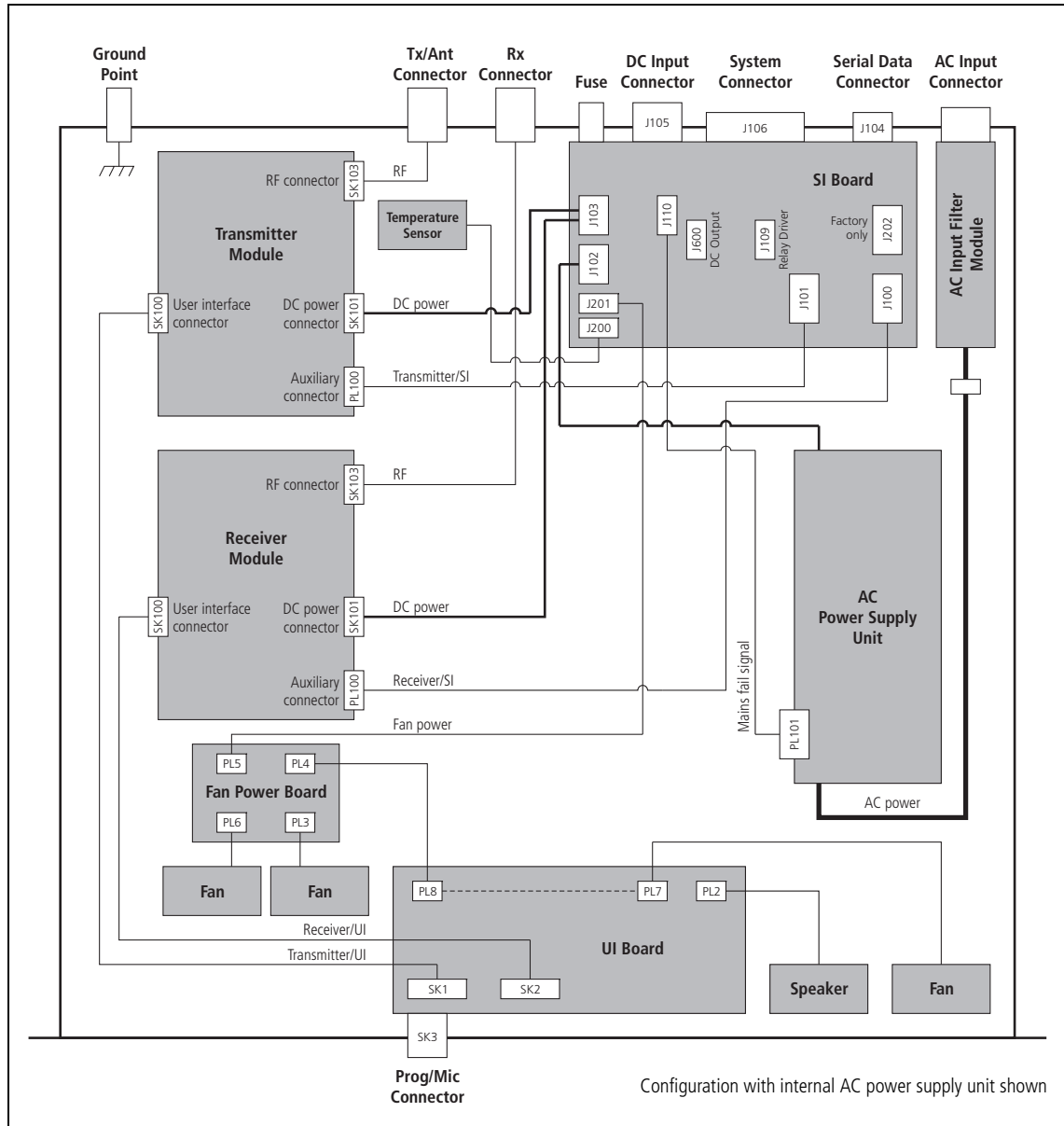

For information on the factory connector and the internal options connector of the transmitter and receiver, refer to the PCB information.

4.1 External Connectors

Figure 4.2 shows the external connectors:

Figure 4.2 External connectors (configuration with internal AC Power supply unit shown)

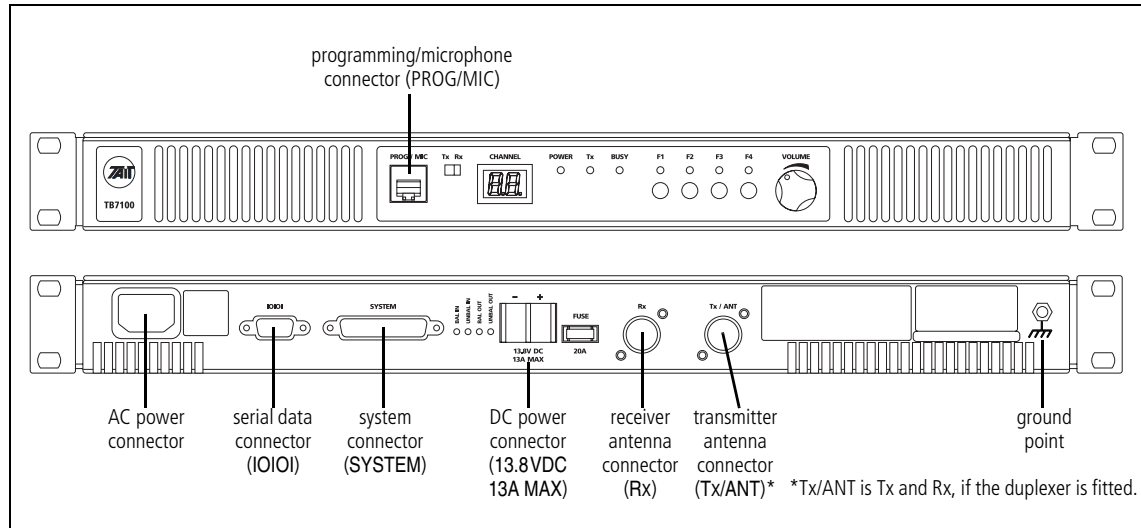

AC Power Connection

If an internal AC power supply unit is fitted, the AC power supply will accept mains input voltages of either 195 VAC to 264 VAC or 99 VAC to 135 VAC. Refer to the ratings label on the rear of the base station.

The AC power connector at the rear of the base station is a standard 3-way AC pin connector.



Warning!! The internal AC power supply unit contains voltages that may be lethal. Refer to the ratings label on the rear of the base station. The internal AC power supply contains no user-serviceable parts.



Important Before connecting to the AC power connector, refer to the ratings label on the rear of the base station for its configured mains voltage.

The base station must be installed so that the rear of the base station is located in a service access area. The plug of the AC power supply cord is intended as the disconnect device. Therefore, the socket-outlet must be installed near the equipment and must be readily accessible.

Ensure that all power sources (AC and DC) are disconnected before opening the base station.

DC Power Connection

The base station is designed to accept a nominal 13.8V DC, with negative ground.



Note The base station will not charge the battery via the DC power connector when an internal AC power supply unit is fitted.

The DC power connector (J105) at the rear of the base station is a heavy-duty M4 screw terminal connector suitable for many forms of connection.

	Pin	Signal Name	Signal Type	Notes
<p>external view</p>	1	13.8VDC	input	
	2	ground	input	

You must connect the DC supply from the battery to the base station via a readily accessible disconnect device such as a fuse or DC-rated circuit breaker with the appropriate rating, as shown in the table below. The DC input leads should be of a suitable gauge to ensure less than 0.2V drop at maximum load over the required length of lead.

Nominal Supply Voltage	Input Voltage Range	Circuit Breaker/Fuse Rating	Recommended Wire Gauge ^a
13.8VDC	10VDC to 16VDC	20A	8AWG / 8.35mm ²

a. For a length of 1.5m to 2m (5ft to 6.5ft) (typical).

Terminate the DC input leads with a suitable crimp connector for attaching to the J105 M4 screws.

Figure 4.3 Recommended DC power connection

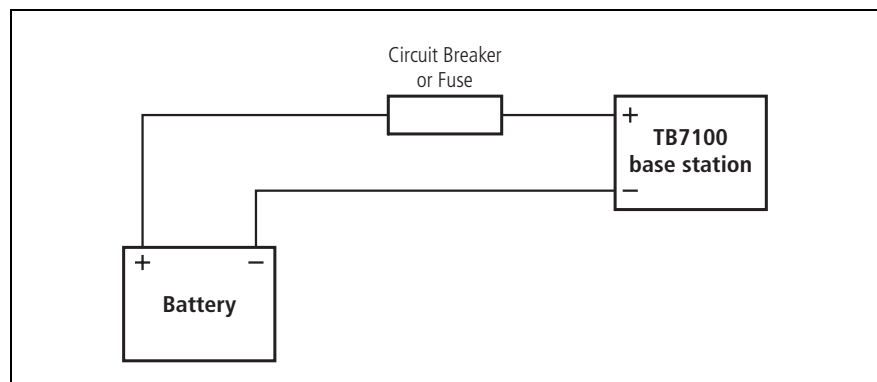

Ground Point

The ground point is a terminal for grounding the tray to the mounting rack.

**RF Connections
(Rx and Tx/ANT)**

The RF input to the base station is via the **RX** connector (N-type) on the rear panel of the base station. The RF output is via the **Tx/ANT** connector (N-type) on the rear panel of the base station.

The RF connector is an N-type connector with an impedance of 50Ω.

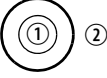

Important The maximum RF input level is +27 dBm. Higher levels may damage the radio.

	Pin	Signal Name	Signal Type	Notes
 rear view	1	RF	RF analog	
	2	GND	RF ground	

**System Connector
(SYSTEM)**

The system connector (J106) at the rear of the base station is a 25-way standard-density D-range socket.

Pin	Signal Name	Signal Type	Notes
1	Rx line output +	audio output	transformer isolated line <6dBm
2	Tx/Rx digital input 1 (AUX_GPI1)	input	high ≥ 1.7 V, low ≤ 0.7 V
3	Tx/Rx digital input 2 (AUX_GPI2)		
4	Rx line output –	audio output	transformer isolated line
5	Tx line input +	audio input	transformer isolated line
6	Tx/Rx digital input 3 (AUX_GPI3)	input	high ≥ 1.7 V, low ≤ 0.7 V
7	Tx/Rx digital input 4 (AUX_GPIO4)	input	output: high ≥ 3.1 V (no load), low < 0.6 V (10mA sink) input: high ≥ 1.7 V, low ≤ 0.7 V
8	Tx line input –	audio input	transformer isolated line
9	RSSI	output	DC signal, 0.6 to 2.5V
10	Tx digital in/out 1 (TX_AUX_GPIO5)	input/output	output: high ≥ 3.1 V (no load), low < 0.6 V (10mA sink) input: high ≥ 1.7 V, low ≤ 0.7 V
11	Tx audio input	audio input	
12	Tx digital in/out 2 (TX_AUX_GPIO6)	input/output	output: high ≥ 3.1 V (no load), low < 0.6 V (10mA sink) input: high ≥ 1.7 V, low ≤ 0.7 V
13	ground	ground	
14	Rx gate	output	open collector
15	Tx key	input	active low
16	Rx relay (comm)	output	opto-isolated
17	Rx relay (NO or NC)		
18	Rx Inhibit	input	0 to 3.3V, active low
19	Rx digital in/out 1 (RX_AUX_GPIO5)	input/output	output: high ≥ 3.1 V (no load), low < 0.6 V (10mA sink) input: high ≥ 1.7 V, low ≤ 0.7 V
20	Tx Opto input +	input	input voltage range 10VDC to 60VDC
21	Tx Opto input –	input	
22	Rx digital in/out 2 (RX_AUX_GPIO6)	input/output	output: high ≥ 3.1 V (no load), low < 0.6 V (10mA sink) input: high ≥ 1.7 V, low ≤ 0.7 V
23	Digital output/Tx relay	output	active low, sinks up to 250mA
24	Rx audio output	output	$< 4.4V_{pp}$
25	13.8 volt output	power output	resetable SMD fuse 1.5A

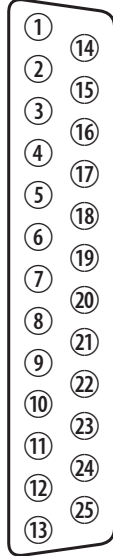

external view

Serial Data Connector (IOIOI)

The serial data connector (J1054) labelled IOIOI is a 9-way female D-range connector, which provides a data connection to the base station.

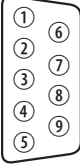
	Pin	Signal Name	Signal Type	Notes
 <p>external view</p>	1	not connected	not used	
	2	receive data	output	data transmitted by TB7100
	3	transmit data	input	data received by TB7100
	4	not connected	not used	
	5	ground	ground	
	6	not connected	not used	
	7	ready to transmit	output	request to send
	8	clear to send	input	clear to send
	9	not connected	not used	



Note For programming the base station, the PROG/MIC port must be used (see below).

Programming/Microphone Connector (PROG/MIC)

The PC running the programming and calibration application is connected to the base station via the programming/microphone connector (SK3) of the UI board. The programming/microphone connector is an 8-way RJ45 socket.

Use the TPA-SV-006 or the T2000-A19 programming lead and a TMAA20-04 adapter to connect the PC to the base station. It is possible to plug the RJ11 directly into the RJ45 socket without the use of the adapter, but this is not recommended. A microphone can also be connected to the base station via this connector.

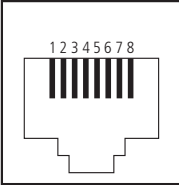
	Pin	Signal Name	Signal Type	Notes
 <p>external view</p>	1	not connected		not connected
	2	+13V8_SW	output	+13.8V, 250mA
	3	TXD	input	transmit data
	4	PTT	input	PTT
	5	MIC_AUD_IN	input	voice band (microphone) input
	6	GND	ground	
	7	RXD	output	receive data
	8	not connected		not connected

4.2 Internal Connectors

4.2.1 Transmitter and Receiver Connectors

The internal connectors of the transmitter and receiver are the same for both modules.



Note Whilst the internal connectors may be physically similar, the signals on the user interface connectors are different for the transmitter and the receiver.

RF Connectors

The RF connectors of the transmitter and the receiver are N-type connectors with an impedance of 50Ω .

DC Power Connectors

The DC power connectors of the transmitter and the receiver are the interface for the primary 13.8V power source. There are different DC power connectors for the 50W/40W and 25W versions.

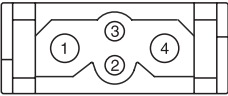
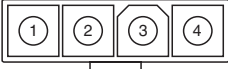
	Pin	Signal name	Signal type	Notes
<div style="display: flex; flex-direction: column; align-items: center;"> <div style="text-align: center;"> 50W/40W  external view </div> <div style="text-align: center; margin-top: 10px;"> 25W  external view </div> </div>	1	AGND	ground	
	2	SPK-	analog output	not connected
	3	SPK+	analog output	not connected
	4	13.8VDC	DC power input	

Auxiliary Connectors

The auxiliary connectors of the transmitter and receiver are 15-way standard-density D-range sockets.

Pin	Signal Name	Signal Type		Notes
		Transmitter	Receiver	
1	AUX GPIO7	bidirectional		Rx = Gate / Tx = Key
2	AUX GPIO5	bidirectional		BCD 3 (default)
3	AUX RXD	input		
4	AUX GPI3	input		BCD 2 (default)
5	AUX GPI2	input		BCD 1 (default)
6	RSSI	output		
7	AUX TAP IN	input		
8	13.8VDC SW	output		
9	AUX GPIO6	bidirectional		
10	AUX GPIO4	bidirectional		
11	AUX TXD	output		
12	AUX GPI1	input		BCD 0 (default)
13	AUD TAP OUT	output		
14	AUX MIC AUD	input		
15	AGND	ground		

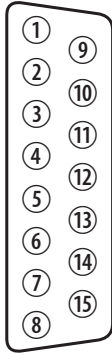

external view

User Interface Connector

The user interface connectors (SK100) of the transmitter and the receiver is a 15-way moulded plastic connector.

Pin	Signal Name	Signal Type		Notes
		Transmitter	Receiver	
1	RX AUD	no connection	no connection	no connection
2	13.8VDC	no connection	output	+13V8DC for UI board
3	CH TXD	input	input	programming data
4	CH PTT	input	no connection	microphone PTT
5	CH MIC AUD	input	output	audio from microphone
6	AGND	ground	ground	analog ground
7	CH RXD	output	output	programming data
8	DGND	ground	ground	digital ground
9	CH ON OFF	output	output	digital ground
10	VOL WIP DC	input	input	volume control
11	CH SPI D0	output	output	
12	CH LE	output	output	
13	CH GPIO1	output	output	digital ground
14	3.3VDC	no connection	output	+3V3DC for UI board
15	CH SPI D1	input	input	
16	CH SPI CLK	output	output	
17	SPK-	no connection	output	speaker audio
18	SPK+	no connection	output	speaker audio

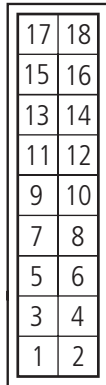

external view
pins 1 to 17 closest to PCB

4.2.2 SI Board Connectors

DC Power Connectors

The two DC power connectors (J102 and J103) on the SI board are heavy-duty M4 screw terminals. J102 (if fitted) accepts power from the internal AC power supply unit. J103 distributes the DC power to the transmitter and the receiver.

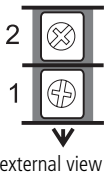
	Pin	Signal Name	Signal Type	Notes
	1	Tx and Rx 13.8VDC	J102 :input J103: output	
	2	Tx and Rx ground	J102 :input J103: output	

System Interface Connector to Transmitter

The system interface connector (J101) to the transmitter is a 16-way surface-mounted connector.

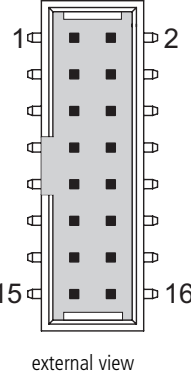
	Pin	Signal Name	Signal Type	Notes
	1	TX_AUX_GPIO7	output	Tx key signal
	2	TX_AUX_GPIO6	bidirectional	digital input/output
	3	TX_AUX_GPIO5	bidirectional	digital input/output
	4	TX_AUX_GPIO4	bidirectional	digital input/output
	5	TX_AUX_RXD	input	data
	6	TX_AUX_TXD	output	data
	7	TX_AUX_GPI3	input	digital input
	8	TX_AUX_GPI1	input	digital input
	9	TX_AUX_GPI2	input	digital input
	10	TX_AUD_TAP_OUT	no connection	
	11	TX_RSSI	no connection	
	12	TX_MIC_AUD	output	
	13	TX_AUD_TAP_IN	output	Tx audio
	14	TX_GND	ground	ground
	15	TX_13V8	no connection	
	16	N/C	no connection	

**System Interface
Connector to
Receiver**

The system interface connector (J100) to the receiver is a 16-way surface-mounted connector.

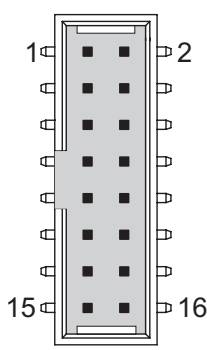
	Pin	Signal Name	Signal Type	Notes
 <p>external view</p>	1	RX_AUX_GPIO7	input	gate signal
	2	RX_AUX_GPIO6	bidirectional	digital input/output
	3	RX_AUX_GPIO5	bidirectional	digital input/output
	4	RX_AUX_GPIO4	bidirectional	digital input/output
	5	RX_AUX_RXD	input	data
	6	RX_AUX_TXD	output	data
	7	RX_AUX_GPIO3	input	digital input
	8	RX_AUX_GPIO1	input	digital input
	9	RX_AUX_GPIO2	input	digital input
	10	RX_AUD_TAP_OUT	input	receive audio
	11	RX_RSSI	input	RSSI
	12	RX_MIC_AUD	no connection	
	13	RX_AUD_TAP_IN	no connection	
	14	RX_GND	ground	ground
	15	RX_13V8	no connection	
	16	N/C	no connection	

4.2.3 UI Board Connectors

User Interface Connector to Transmitter

The user interface connector (SK1) to the transmitter is a 16-way MicroMaTch connector.

Pin	Signal Name	Signal Type	Notes
1	TX_RX_AUD	no connection	no connection
2	TX_+13V8_SW	no connection	no connection
3	TX_CH_TXD	output	programming data
4	TX_CH_PTT	output	microphone PTT
5	TX_MIC_AUD_OUT	output	audio from microphone
6	TX_AGND	ground	analogue ground
7	TX_CH_RXD	input	programming data
8	TX_DGND	ground	digital ground
9	TX_CH_ON_OFF	input	digital ground
10	TX_VOL_WIP_DC	output	no connection
11	TX_CH_SPI_D0	input	
12	TX_CH_LE	input	
13	TX_CH_SPIO1	input	digital ground
14	TX_+3V3	no connection	no connection
15	TX_CH_SPI_DI	output	
16	TX_CH_SPI_CLK	input	
17	TX_CH_SPK-	no connection	no connection
18	TX_CH_SPK+	no connection	no connection

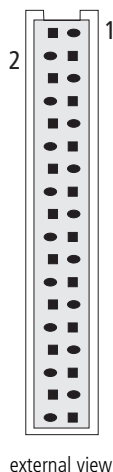

User Interface Connector to Receiver

The user interface connector (SK2) to the receiver is a 16-way MicroMaTch connector.

Pin	Signal Name	Signal Type	Notes
1	RX_RX_AUD	no connection	no connection
2	RX_+13V8_SW	input	+13V8DC for PCB
3	RX_CH_TXD	output	programming data
4	RX_CH_PTT	no connection	no connection
5	RX_MIC_AUD_OUT	input	no connection
6	RX_AGND	ground	analogue ground
7	RX_CH_RXD	input	programming data
8	RX_DGND	ground	digital ground
9	RX_CH_ON_OFF	input	digital ground
10	RX_VOL_WIP_DC	output	volume control
11	RX_CH_SPI_D0	input	
12	RX_CH_LE	input	
13	RX_CH_GPIO1	input	digital ground
14	RX_+3V3	input	+3V3DC for PCB
15	RX_CH_SPI_DI	output	
16	RX_CH_SPI_CLK	input	
17	RX_CH_SPK-	input	speaker audio
18	RX_CH_SPK+	input	speaker audio

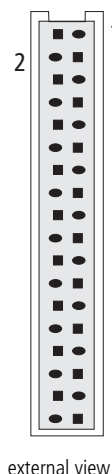

5 Opening and Closing the Base Station

This section describes how to open and close the base station.

Figure 5.1 Opening and closing the base station

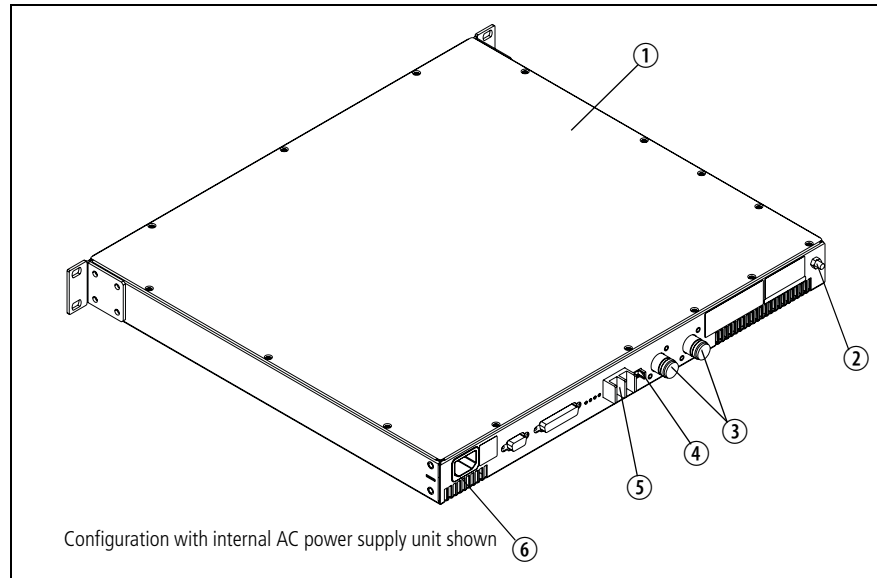

Opening the
Base Station



Warning!! The internal AC power supply unit contains voltages that may be lethal. Refer to the ratings label on the rear of the base station.

Ensure that all power sources (AC and DC) are disconnected before opening the base station.

1. If an internal AC Power supply is fitted, disconnect the base station from AC power ⑥.
2. Remove the fuse ④ at the rear of the base station to disconnect the base station from DC power.
3. Use a Philips #2 screwdriver to disconnect the cables from the DC power connector ⑤.
4. Disconnect the antenna connectors for transmit and receive ③.



Important Before opening the base station, disconnect the base station from any test equipment.

5. Disconnect any other connectors.
6. Disconnect the ground cable from the ground point ②.
7. Use a Torx T10 screwdriver to remove the countersunk screws. Remove the tray cover ①.

**Closing the
Base Station**

1. Place the tray cover ① onto the chassis.
2. Use a Torx T10 torque-driver to fasten the tray cover with the countersunk screws to 4.5lb·in (0.5N·m).
3. Fit the fuse ④ at the rear of the base station.

6 Preparation for Operation

6.1 Introduction

The base station operation can be modified by the use of links (see [Table 6.1](#)) and programmable settings.

The base station can be configured for operation in the following basic modes of operation:

- Line-controlled base: The base station transmit audio and key is derived via the system interface. Audio response is link-selectable.
- Talk through repeater (voice): The receiver audio is directly connected to the transmitter and the transmitter is keyed by the receiver gate. Audio response in this mode is software-selectable.
- RF modem: Data on the serial interface is connected to the transmitter and the receiver.
- Data repeater: The received data line is connected to the transmit data line. receiver gate and transmitter key signals are not used.
- TaitNet trunking.

Table 6.1 System Interface links

Link ^a	Function	Setting
J206	Fan Control	1-2 J207 Controlled 2-3 Always On
J207	Fan Control	1-2 Tx Key Controlled 2-3 Temperature Controlled
J221	RS-232 Loop Back	1-2 RS-232 via serial port 2-3 Loop Back
J222	Fan activation temperature	Test point
J223	Heat sink temperature	Test point
RV200	Fan Activation Temperature	Adjustment
W300	Tx / Rx GPIO 5 Link	When fitted Tx Digital in/out 1 is connected to Rx Digital in/out 1. Used for applications where both modules need to respond to one input eg BCD Channel selection.
W301	Tx / Rx GPIO 6 Link	When fitted Tx Digital in/out 2 is connected to Rx Digital in/out 2. Used for applications where both modules need to respond to one input eg BCD Channel selection.

Table 6.1 System Interface links (Continued)

Link ^a	Function	Setting
W302	Tx Key to GPIO6 Link	When fitted Tx Key is connected to Tx Digital in/out 2. Used for applications where the Tx Key signal must also trigger an additional action.
J400	Tx Key Source	1-2 External 2-3 Rx Gate
J401	Rx Relay polarity control	1-2 Active High 2-3 Active Low
W401 W402	Tone on Idle Enable	Fit both links to enable TOI Remove both links to disable
RV400	Tone on Idle Frequency	Frequency Adjust
RV401	Tone on Idle Level	Level Adjust
J500	Line out frequency response	1-2 Flat 2-3 De-Emph
J501	Line in frequency response	1-2 Flat 2-3 Pre-Emph
J502	Tx Audio Source	1-2 Line / Unbalanced in 2-3 Rx Audio (repeater)
J503	Rx Audio Destination	1-2 Tx Audio (repeater) 2-3 Line / Unbalanced out
J507	Tx Line In Destination	1-2 Tx Mic Audio 2-3 Tx Audio Tap In
RV500	Balanced Line In	Sensitivity Adjust
RV501	Unbalanced Line In	Sensitivity Adjust
RV502	Unbalanced Line Out	Level Adjust
RV503	Balanced Line Out	Level Adjust

a. The positions of these links on the PCB are illustrated later in this section. They are also illustrated in TN-1264-AN.

6.2 Mode of Operation

This section shows how to set up the base station for various modes of operation.

Examples are:

- line-controlled base
- talk through repeater
- RF modem

- data repeater
- TaitNet trunking.

Where applicable, the procedure for setting any of the audio levels or other adjustment points will be described, along with the procedure for measuring a variety of parameters commonly monitored.

To verify the operation of the base station it is best to configure it as a line-controlled base first. In this mode of operation the receiver and transmitter modules can be independently tested because all the audio inputs and outputs are accessible via the system interface connector. When the base station has been tested as a line-controlled base, it is then a simple process to change the links to the required mode of operation and perform any additional functional testing required for that mode of operation.

6.3 Line-controlled Base

In the line-controlled base mode the audio and control signals are routed from the external 25-way D-range connector through the SI board to the receiver and transmitter modules. External equipment is used to control the operation of the base station.

Figure 6.1 Line-controlled base

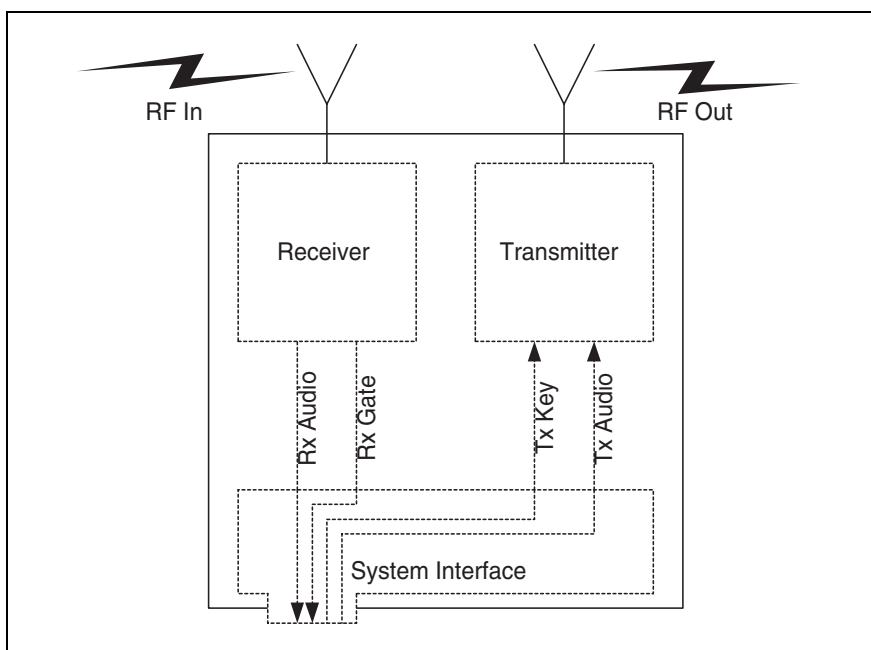

6.3.1 Test Equipment Required

The following test equipment is used to setup the base station for line-controlled base operation:

- TBA0STU calibration test unit (CTU) which includes the CTU adaptor

- and CTU cable, or
- TBA0ST1 calibration test unit (CTU), TBB0STU-TBB CTU adaptor (220-02068-xx) and CTU cable (219-02888-xx)
- PC, programming cables and the TB7100 programming application
- digital voltmeter
- DC power supply (not necessary with internal AC power supply unit option)
- RF test set with:
 - RF power meter
 - modulation analyser
 - RF signal generator
 - sinad meter
 - audio distortion meter
 - audio level meter
 - audio signal generator.

Calibration Test Unit (CTU)

The CTU is used to configure and test the base station. The same CTU is used for TB8000 and TB9000 base station equipment, so only some of the features on the CTU apply to the TB7100 base station. The CTU adaptor is plugged into the system connector of the CTU. The CTU cable is plugged into the system connector of the base station.



Note Do not plug the adaptor into the base station - it **must** be plugged into the CTU.

For more information on the CTU refer to the TBA0STU/TBA0STP Calibration and Test Unit Operation Manual (MBA-00013-xx).

6.3.2 Test Equipment Setup

1. Connect the PC to the programming port on the front panel of the base station. See [“Connecting to the PC” on page 88](#).
2. Plug the adaptor into the system connector on the CTU. Connect the adaptor cable to the system connector of the base station.



Note Connections between the CTU and the test equipment will vary and are described in the relevant test steps.

3. Ensure all switches on the CTU are in the 1 or OFF position (inactive).
4. Connect the receiver N-type connector to the RF test set (signal generator) output port.
5. Connect the transmitter N-type connector to the RF test set (power and modulation meter) input port, check the test set is rated for the transmit power of the base station.

- Connect the 13.8V power supply to the DC input on the base station, ensuring correct polarity.

Figure 6.2 Test setup with CTU (TBA0STU)

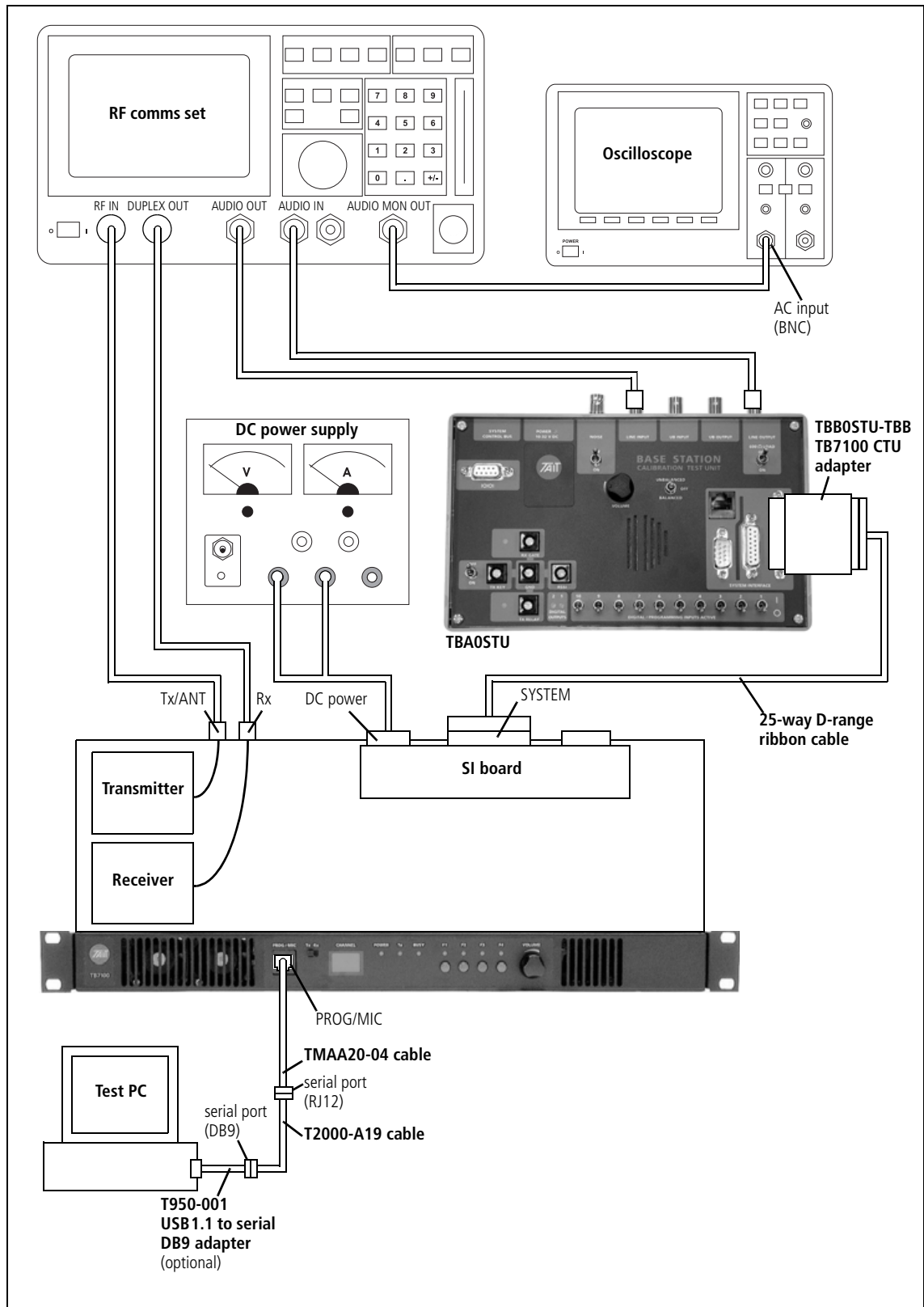

6.3.3 Link Settings

1. Remove the cover as detailed in [“Opening the Base Station” on page 57.](#)
2. Set the following links on the SI board.



Note Links of the mandatory settings must be in the position indicated. Links of the optional settings must be in one of the positions listed. The defaults are generally recommended.

3. Fit the cover as detailed in [“Closing the Base Station” on page 58.](#)

Table 6.2 Line-controlled base—mandatory settings

LINK	Name	Pins	Position	Function	Comments
J400	Tx Key Source	3	1-2	Line-controlled Base mode	External PTT signal to transmitter
J502	Tx Audio Source	3	1-2	Line-controlled Base mode	Balanced and unbalanced audio inputs to transmitter
J503	Rx Audio Destination	3	2-3	Line-controlled Base mode	Received audio to balanced and unbalanced audio outputs
W401 W402	TOI 9V Enable TOI 4.5V Enable	2 2	Not fitted	Tone on Idle disable	Refer “Tone On Idle (TOI)” on page 102 to enable idle tone.

Table 6.3 Line-controlled base—optional settings

LINK	Name	Pins	Position	Function	Comments
J401	Relay Polarity Control	3	1-2 2-3	Energised for receiver active gate Energised for receiver inactive gate	Default is 1-2
J500	Line Out Frequency Response	3	1-2 2-3	Flat response De-emphasis	Default position is 2-3
J501	Line In Frequency Response	3	1-2 2-3	Flat response Pre-emphasis	Default position is 2-3
J507	Line In Destination	3	1-2 2-3	Tx Line In to Aux Mic Tx Line In to Audio Tap In	Default position is 2-3. Position 1-2 is usually used only by trunking systems.
J206	Fan Control 1	3	1-2 2-3	Fan controlled by J207 Fan always on	Default position is 1-2
J207	Fan Control 2	3	1-2 2-3	Fan Tx key-controlled Fan temperature-controlled	Default position is 2-3

6.3.5 Programming

To program a base station for line-controlled base operation follow the instructions below. Do not add CTCSS or any additional settings at this stage. These are covered in [“Programmable Features” on page 88](#). See [“Connecting to the PC” on page 88](#) before beginning.

Transmitter

1. Place the transmit/receive programming switch on the user interface into the transmit position.
2. Read the transmitter or start with a new transmitter data file.
3. Use the reset to defaults command under the file menu to ensure all the mandatory and recommended settings are in their correct default states.
4. Open the specifications form and select the correct RF band, not required if the transmitter file was read.
5. Open the channels form and add as many channels as are required. For each channel enter the:
 - transmit frequency
 - Tx subaudible signalling value (leave as “None”)
 - power level
 - bandwidth.
6. Open the key settings form and select the required function for each function key.
For example:
 - FN1 = Preset Channel
 - FN2 = Preset Channel
 - FN3 = Preset Channel
 - FN4 = None
7. Program the transmitter.

Receiver

1. Place the transmit/receive programming switch on the user interface into the receive position.
2. Read the receiver or start with a new receiver data file.
3. Use the reset to defaults command under the file menu to ensure all the mandatory and recommended settings are in their correct default states.
4. Open the specifications form and select the correct RF band, not required if the receiver file was read.
5. Open the channels form and add as many channels as are required. For each channel enter:
 - receive frequency

- Rx subaudible signalling value (leave as “None”)
 - squelch setting
 - bandwidth.
6. Open the key settings form and select the required function for each function key.
For example:
 - FN1 = Preset Channel (same as transmitter)
 - FN2 = Preset Channel (same as transmitter)
 - FN3 = Preset Channel (same as transmitter)
 - FN4 = Monitor / Squelch override
 7. Program the receiver.

6.3.6 Receiver Audio Level Adjustment

- Unbalanced Line**
1. Connect the unbalanced output from the CTU to the audio input port on the test set and set up the test set to measure the audio level.
 2. Set the RF signal generator to the correct RF frequency, modulated with a 1kHz audio tone at 60% of full system deviation.
 3. Set the RF output level to -70dBm.
 4. Verify that the receiver gate opens and the busy LED turns on.
 5. Adjust RV502 (UNBAL OUT) on the rear panel to set the unbalanced output to the required level (typically 1 Vp-p, or 354mV Rms).
- Balanced Line**
1. Connect the line output from the CTU to the audio input port on the test set and set up the test set to measure the audio level.
 2. Turn the CTU 600 ohm switch on.
 3. Set the RF signal generator to the correct RF frequency modulated with a 1kHz audio tone at 60% of full system deviation.
 4. Set the RF output level to -70dBm.
 5. Verify that the receiver gate opens and the busy LED turns on.
 6. Adjust RV503 (BAL OUT) on the rear panel to set the balanced output to the required level (typically -10dBm).

6.3.7 Receiver Functional Testing

This section describes how to test some parameters which are commonly monitored.

Sensitivity

The sensitivity can be measured using either the balanced or unbalanced audio output.

1. Connect the required audio output from the CTU to the audio input port on the test set.
2. Connect the RF output from the test set to the Rx input on the rear panel.
3. Set up the test set to measure the SINAD level.
4. Set the RF signal generator to the correct RF frequency, modulated with a 1kHz audio tone at 60% of full system deviation.
5. Set the RF output level to -70dBm.
6. Verify that the receiver gate opens and the busy LED turns on.
7. Reduce the RF level until 12dB SINAD is obtained.



Note This level will vary depending on the bandwidth and frequency response of the channel. Consult the specifications manual for values.



Note If the mute closes before 12dB SINAD is reached then squelch override may be programmed to a function key. Pressing this key will prevent the mute from closing.

RSSI Level

1. Connect a voltmeter to the RSSI test point on the CTU.
2. Set the RF signal generator to the correct RF frequency.
3. Set the RF level to -100dBm.
4. Verify the RSSI voltage is $1.1V \pm 300mV$.



Note If necessary adjust the RF level from -50dBm to -115dBm and verify that the RSSI voltage changes at 25mV/dB.

Mute Thresholds

The mute thresholds can be measured using either the balanced or unbalanced output.

1. Connect the required audio output from the CTU to the audio input port on the test set.
2. Set up the test set to measure the SINAD level.
3. Set the RF signal generator to the correct RF frequency, modulated with a 1kHz audio tone at 60% of full system deviation.

4. Set the RF output level to -70 dBm.
5. Verify that the receiver gate opens and the busy LED turns on.
6. Reduce the RF level until the mute closes. This RF level is the mute close threshold.
7. Increase the RF level until the mute opens. This RF level is the mute open threshold.
8. The difference between these two levels is the mute hysteresis.



Note The mute thresholds are determined by the squelch setting programmed in the receiver's channel table.



Note If the thresholds are not suitable use the calibration application to change the squelch setting on the channel table.

Distortion

The Rx Distortion can be measured using either the balanced or unbalanced output.



Note Before beginning this test verify the test set is rated to handle the transmit power being tested.

1. Connect the required audio output from the CTU to the audio input port on the test set.
2. Set up the test set to measure the distortion level.
3. Set the RF signal generator to the correct RF frequency, modulated with a 1 kHz audio tone at 60% of full system deviation.
4. Set the RF output level to -70 dBm.
5. The measured distortion level should be within the receiver specifications as detailed in the specifications manual.

6.3.8 Transmitter Audio Level Adjustment

Balanced Line

1. Set up the test set to measure the transmitter modulation level.
2. Connect the CTU line input to the audio output port on the test set.
3. Set up the test set audio output to be 1 kHz at the required line level (typically -10 dBm).
4. Activate the Tx Key switch and verify that the transmission is at the programmed power and frequency.
5. Adjust RV500 (BAL IN) on the rear panel to the required deviation (typically 60% of full system deviation).

Unbalanced Line

1. Set up the test set to measure the transmitter modulation level.

2. Connect the CTU unbalanced input to the audio output port on the test set.
3. Set up the test set audio output to be 1 kHz at the required line level (typically 1 V_{p-p}).
4. Activate the Tx Key switch and verify that the transmission is at the programmed power level and frequency.
5. Adjust RV501 (UNBAL IN) on the rear panel to the required deviation (typically 60% of full system deviation).

6.3.9 Transmitter Functional Testing

This section describes how to test some parameters commonly found on RF channel test sheets.

Tx Power and Frequency

1. Set up the test set to measure frequency and power level.
2. Activate the Tx Key switch on the CTU.
3. Verify that the measured power level and frequency match the programmed settings, within the expected accuracy of the test set and taking into account cable losses.



Note If the measured value does not agree with the programmed settings, the transmitter module is either faulty or needs recalibrating.

Audio Distortion

When measuring the transmitter audio distortion, the audio input signal can be via either the balanced or unbalanced audio input.

1. Connect the audio output from the test set to the required CTU audio input.
2. Set up the modulation analyser in the test set to measure the distortion of the modulated audio signal.
3. Set up the test set audio generator output to be 1 kHz and at the level required to produce 60% full system deviation (this is the same level used in the audio level adjustment section).
4. Activate the Tx Key switch and verify that the measured deviation is 60% of full system deviation.
5. The measured distortion level should be within the transmitter specifications as detailed in the specifications manual.



Note If the measured value does not agree with the programmed settings, the transmitter module is either faulty or needs recalibrating.

Maximum Deviation

When measuring the maximum deviation, the audio input signal can be via either the balanced or unbalanced audio input.

If CTCSS is to be added, this should be done before carrying out this test. Refer to “[Enabling Subaudible Signalling](#)” on page 98 for instructions.

1. Set up the test set to measure the deviation of the RF signal.
2. Connect the audio output from the test set to the required CTU audio input.
3. Set up the test set audio generator output to be 1 kHz and at the required level to produce 60% full system deviation (this is the level used in the audio level adjustment section).
4. Activate the Tx Key switch and verify that the measured deviation is 60% of full system deviation.
5. Increase the test set audio generator output level by 20 dB and sweep the audio frequency from 100 Hz to 4 kHz.
6. The maximum measured deviation level should not exceed the full system deviation programmed for the channel.



Note If the measured value exceeds the programmed settings, the transmitter module is either faulty or needs recalibrating.

6.4 Talk Through Repeater

Once the base station has been set up and tested as a line-controlled base, it is simple to convert it into a talk through repeater. In this mode of operation the received audio and receiver gate from the receiver module are looped back to the transmitter.

Figure 6.4 Talk through repeater

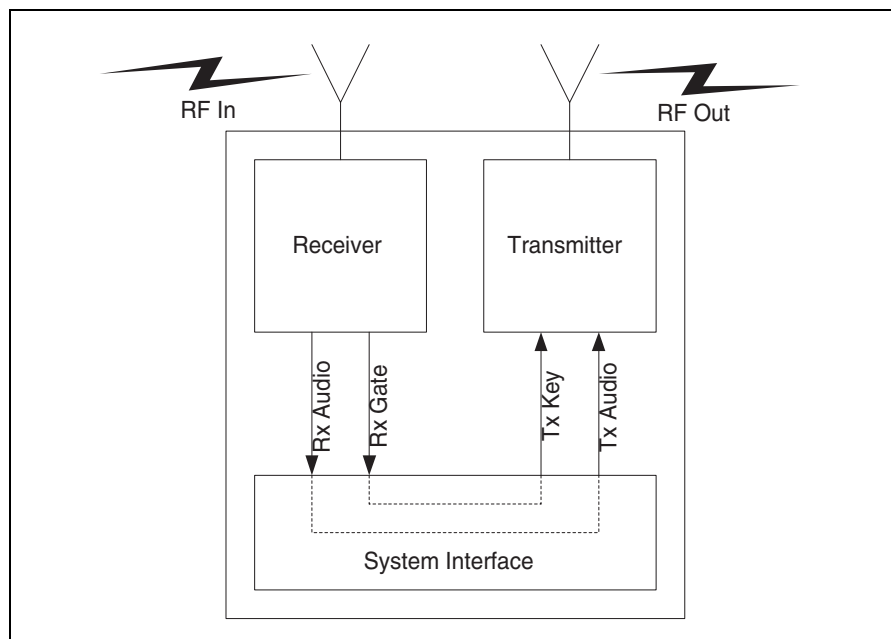

6.4.1 Test Equipment Required

The following test equipment is used to setup the base station for talk through repeater operation:

- PC, programming cables and the TB7100 programming application
- digital voltmeter
- DC power supply
- RF test set with:
 - RF power meter
 - modulation analyser
 - RF signal generator
 - sinad meter
 - audio distortion meter
 - audio level meter
 - audio signal generator.

6.4.2 Test Equipment Setup

1. Connect the PC to the programming port on the front panel of the base station. See [“Connecting to the PC” on page 88](#).
2. Connect the receiver N-type connector to the RF test set (signal generator) output port.
3. Connect the transmitter N-type connector to the RF test set (power and modulation meter) input port, check the test set is rated for the transmit power of the base station.
4. Connect the 13.8V power supply to the DC input on the base station, ensuring correct polarity.

6.4.3 Link Settings

1. Remove the cover as detailed in [“Opening the Base Station” on page 57](#).
2. Set the following links on the SI board.



Note Links of the mandatory settings must be in the position indicated. Links of the optional settings must be in one of the positions listed. The defaults are generally recommended.

3. Fit the cover as detailed in [“Closing the Base Station” on page 58](#).

Table 6.4 Talk through repeater—mandatory settings

LINK	Name	Pins	Position	Function	Comments
J400	Tx Key Source	3	2-3	Talk Through Repeater mode	Receiver gate keys transmitter
J502	Tx Audio Source	3	2-3	Talk Through Repeater mode	Transmitter audio taken from the receiver
J503	Rx Audio Destination	3	1-2	Talk Through Repeater mode	Received audio to the transmitter mode
W401 W402	TOI 9V Enable TOI 4.5V Enable	2 2	Not fitted	Tone on Idle disable	Tone on idle not used in repeater configuration

Table 6.5 Talk through repeater—optional settings

LINK	Name	Pins	Position	Function	Comments
J507	Line In Destination	3	1-2 2-3	Tx Line In to Aux Mic Tx Line In to Audio Tap In	Default position is 2-3
J206	Fan Control 1	3	1-2 2-3	Fan controlled by J207 Fan always on	Default position is 1-2
J207	Fan Control 2	3	1-2 2-3	Fan Tx key-controlled Fan temperature-controlled	Default position is 2-3



Note By default the audio frequency response will be flat.

Figure 6.5 Link positions on the SI board

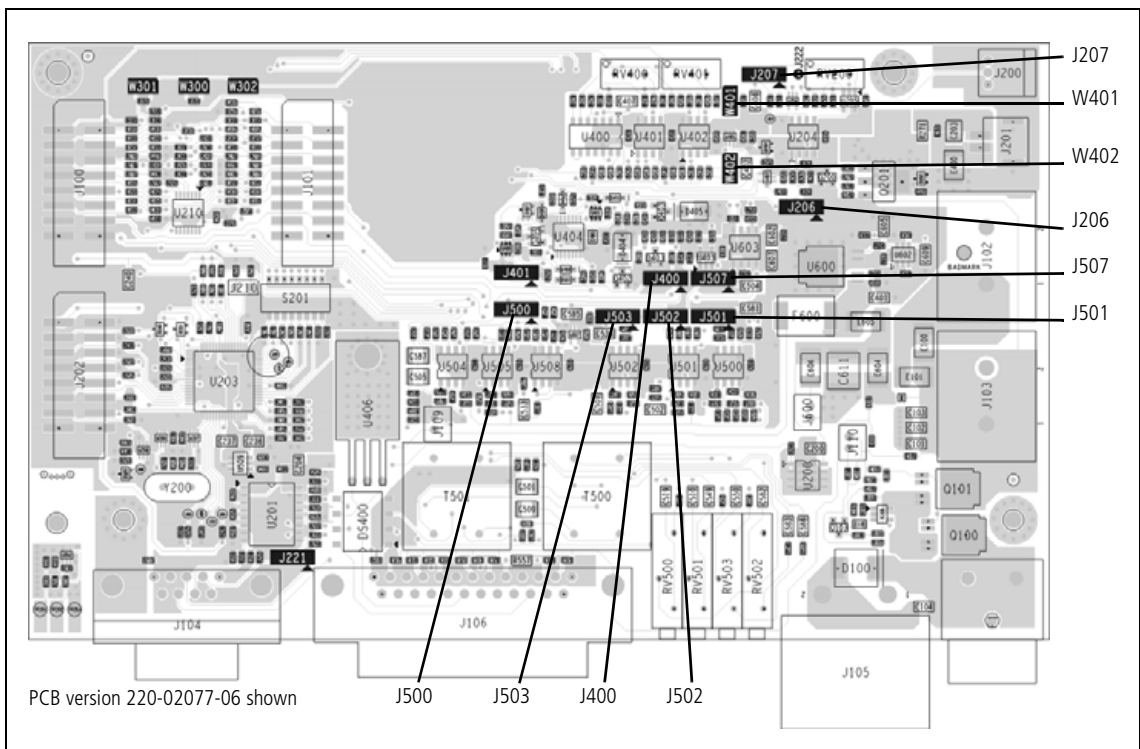

6.4.4 Applying Power

Before turning on the base station, check that:

- all looms and cables at the front and rear of the base station are fitted correctly
- all connectors are secure
- the 20A fuse is fitted.

Turn on the power supply and check that the base station powers up correctly:

- The power LED on the user interface lights up.
- The LCD indicates the current channel number.

6.4.5 Programming

No changes to the values programmed for line-controlled base operation are required. See [“Programming” on page 66](#) for details.



Note If a soft tail setting is required see later in this chapter [“Soft Off \(Tx Tail Time\)” on page 100](#).

6.4.6 Audio Level Adjustment

There is no audio level adjustment necessary in repeater mode. The internal linking is designed to produce a repeater with no talk through gain. If talk through gain is required it can be implemented by linking back the audio using a DB25 connector on the SI board and setting the audio levels as required, see [“Alternate Talk Through Repeater Configuration” on page 75](#) for a more detailed explanation.

6.4.7 Talk Through Repeater Functional Testing

The basic operation of the base station has already been tested as a line-controlled base. This section describes the additional functional tests required to verify that the base station is operating correctly as a repeater.

Repeater Key

With the test set in duplex mode:

1. Set up the test set to measure the transmitter power and frequency output.
2. Set the RF signal generator to the correct frequency for the receiver.



Note If subaudible signalling has been added, also modulate the carrier with the required signal.

3. Set the RF level to -70 dBm.

4. The receiver busy LED turns on and the transmitter keys up and transmits at the programmed power level and frequency. When the RF source is removed, the transmitter will stop transmitting.

Talk Through

With the test set in duplex mode:

1. Set up the test set to measure the modulation level and frequency.
2. Set the RF signal generator to the correct frequency for the receiver.
3. Modulate the RF carrier with a 1kHz audio tone at 60% full system deviation.



Note If subaudible signalling has been added, also modulate the carrier with the required signal.

4. Set the RF level to -70 dBm.
5. The receiver busy LED turns on and the transmitter keys up and transmits at the programmed power level and frequency. The transmitted signal will be the same as received. If subaudible signalling has been enabled, the required sub-tone will also be transmitted.
6. Ensure the deviation is at the desired level.

6.4.8 Alternate Talk Through Repeater Configuration

Audio Frequency Response

When a talk through repeater is created by linking the audio path using links J502 and J503, the default frequency response is flat audio. The pre/de-emphasis links J500 and J501 are not in the audio path and have no effect.

Repeater Talk Through Gain

When a talk through repeater is created by linking the audio path using links J502 and J503, the repeater will have no talk through gain. If talk through gain is required internally link the base station for line-controlled base operation. Then externally configure it to operate as a repeater by linking the following pins on a 25pin male D-range connector and plugging the connector into the system connector on the rear panel of the base station.

Pins	Function
1 to 5	Rx Line Out+ to Tx Line In+
4 to 8	Rx Line Out- to Tx Line In-
14 to 15	Rx Gate to Tx Key

When configured as described above:

- The base station will operate as a repeater.
- The Talk through gain can be set by adjusting the line output level and line input sensitivity RV500 (BAL IN) and RV503 (BAL OUT) on the

rear panel.

- The pre/de emphasis links J500 and J501 can be used to set the audio frequency response.

6.5 RF Modem

In RF modem mode the transmitter and receiver are connected to the serial interface and any data on the serial interface is transmitted. Any data received is forwarded to the PC.

Figure 6.6 RF modem

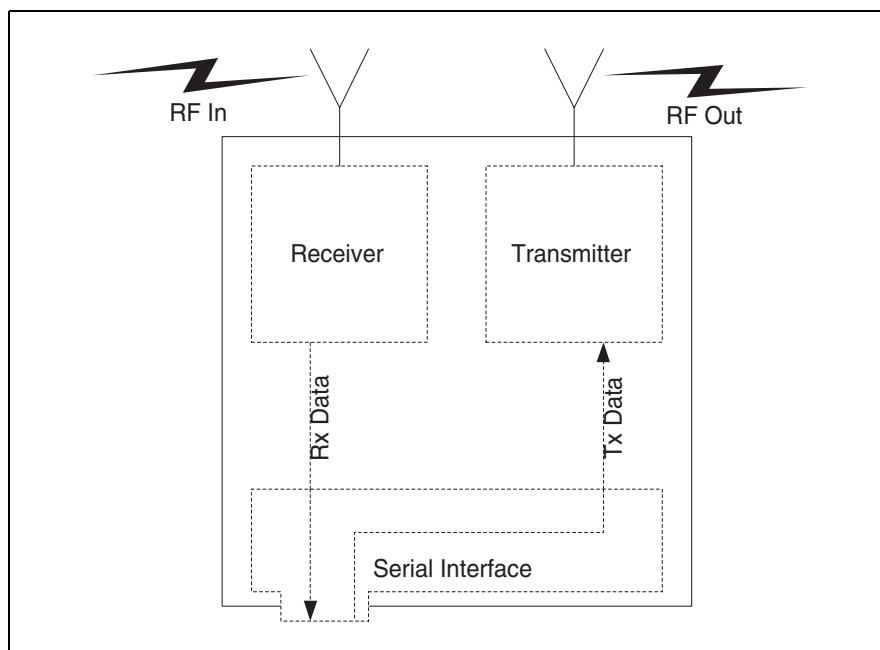

6.5.1 Test Equipment Required

The following test equipment is used to setup the base station for RF modem operation:

- TBA0STU calibration test unit (CTU) which includes the CTU adaptor and CTU cable, or
- TBA0ST1 calibration test unit (CTU), TBB0STU-TBB CTU adaptor (220-02068-xx) and CTU cable (219-02888-xx)
- PC, programming cables and the TB7100 programming application
- digital voltmeter
- DC power supply
- RF test set with:
 - RF power meter
 - modulation analyser

- RF signal generator
- sinad meter
- audio distortion meter
- audio level meter
- audio signal generator

Calibration Test Unit (CTU)

The CTU is used to configure and test the base station. The same CTU is used for TB8000 and TB9000 base station equipment, so only some of the features on the CTU apply to the TB7100 base station. The CTU adaptor is plugged into the system connector of the CTU. The CTU cable is plugged into the system connector of the base station.

For more information on the CTU refer to the TBA0STU/TBA0STP Calibration and Test Unit Operation Manual (MBA-00013-xx).

6.5.2 Test Equipment Setup

1. Connect the PC to the programming port on the front panel of the base station. See [“Connecting to the PC” on page 88](#).
2. Connect the receiver N-type connector to the RF test set (signal generator) output port.
3. Connect the transmitter N-type connector to the RF test set (power and modulation meter) input port, check the test set is rated for the transmit power of the base station.
4. Connect the 13.8V power supply to the DC input on the base station, ensuring correct polarity.

6.5.3 Link Settings

1. Remove the cover as detailed in [“Opening the Base Station” on page 57](#).
2. Set the following links on the SI board.



Note Links of the mandatory settings must be in the position indicated. Links of the optional settings must be in one of the positions listed. The defaults are generally recommended.

3. Fit the cover as detailed in [“Closing the Base Station” on page 58](#).

Table 6.6 RF modem—mandatory settings

LINK	Name	Pins	Position	Function	Comments
J221	RS232 Loop Back	3	1-2	RS-232 out data connector	
J400	Tx Key Source	3	1-2	External Tx key source	Use this setting because the transmitter will automatically key up when there is data to send so should not be keyed by the receiver gate.

Table 6.7 RF modem—optional settings

LINK	Name	Pins	Position	Function	Comments
J206	Fan Control 1	3	1-2 2-3	Fan controlled by J207 Fan always on	Default position is 1-2
J207	Fan Control 2	3	2-3	Fan temperature-controlled	Do not use position 1-2 (Tx key-activated fan). The transmitter will automatically key up when there is data to send. This will not activate the Tx key line and therefore will not activate the fan.

Figure 6.7 Link positions on the SI board

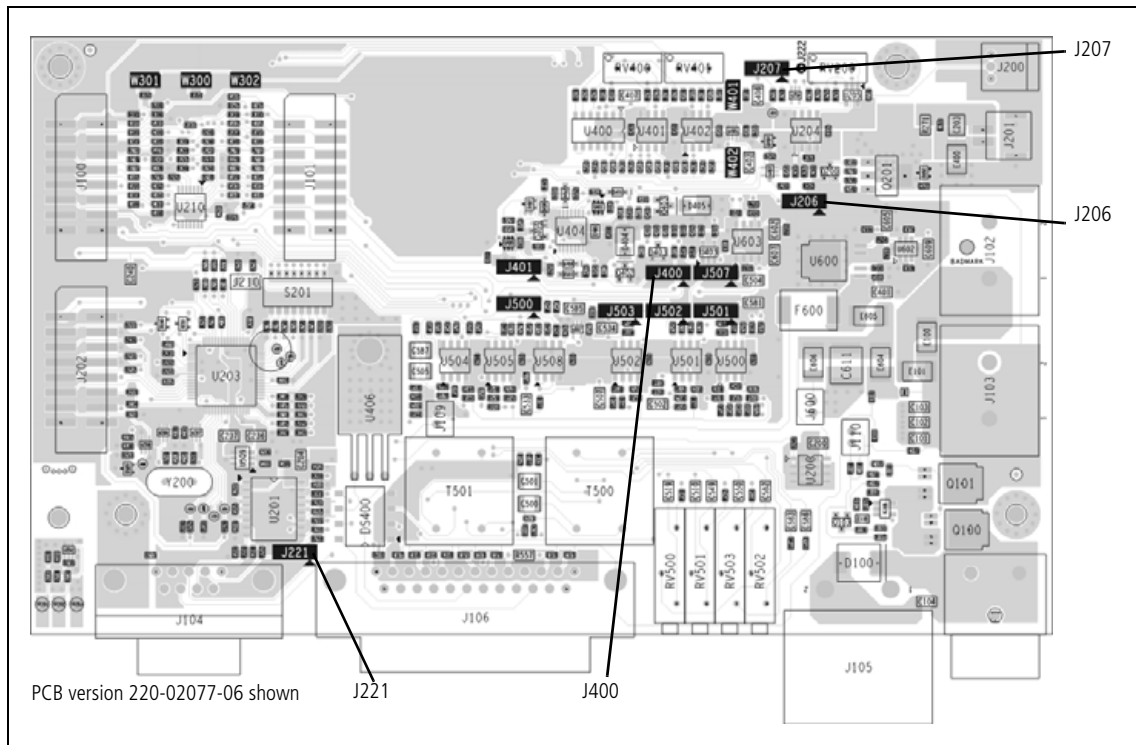

6.5.4 Applying Power

Before turning on the base station, check that:

- all looms and cables at the front and rear of the base station are fitted correctly
- all connectors are secure
- the 20A fuse is fitted.

Turn on the power supply and check that the base station powers up correctly:

- The power LED on the user interface lights up.
- The LCD indicates the current channel number.

6.5.5 Programming

Please see the line-controlled base [“Programming” on page 66](#) for details on how to program the base station for RF modem operation.

6.5.6 Audio Level Adjustment

In this configuration the system interface connector is not used, so it is not necessary to set the line output level or line input sensitivity.

6.5.7 Programming for FFSK Operation

To program a base station for FFSK operation:

Transmitter

1. Read the transmitter or start with a new transmitter data file.
2. Use the reset to defaults command under the file menu to ensure all the mandatory and recommended settings are in their correct default states.
3. Open the specifications form and select the correct RF band
4. Open the channels form summary tab. Add as many channels as are required and for each channel enter the following:
 - transmit frequency
 - Tx subaudible signalling value
 - power level
 - bandwidth.
5. Open the channels form details tab and for each channel check the Use channel for data check box.
6. Open the key settings form and select the required function for each function key. For example:

- FN1 = Preset Channel
 - FN2 = Preset Channel
 - FN3 = Preset Channel
 - FN4 = None.
7. Open the data form and in the general tab:
 - In the command mode section disable all check boxes.
 - In the transparent mode section select transparent mode enabled and de-select the other check boxes.
 - Set Power Up State to FFSK transparent mode.
 8. Open the data form and in the serial communications tab:
 - In the serial communications setup field set the FFSK transparent mode baud rate to 1200, the Flow control to None and the data port to the required data port.
 - Ensure hardware flow control is set to None.
 9. Open the data form RF modems tab. The THSD modem settings do not apply and can be ignored. In the FFSK modem section set up the following:
 - Ignore CTCSS/DCS can be disabled (CTCSS/DCS is not used in this example).
 - Enable Check Packet Length.
 - Disable FFSK Tone Blanking.
 - FFSK Lead-In Delay default of 500ms is suitable but can be changed.
 - FFSK Lead-Out Delay default of 200ms is suitable but can be changed.
 10. Program the transmitter

Receiver

1. Read the receiver or start with a new receiver data file.
2. Use the reset to defaults command under the file menu to ensure all the mandatory and recommended settings are in their correct default states.
3. Open the specifications form and select the correct RF band.
4. Open the channels form summary tab. Add as many channels as are required and for each channel enter the following:
 - receive frequency
 - Rx subaudible signalling value
 - squelch setting
 - bandwidth.
5. Open the channels form details tab and for each channel check the use channel for data check box.

6. Open the key settings form and select the required function for each function key. For example:
 - FN1 = Preset Channel (same as transmitter)
 - FN2 = Preset Channel (same as transmitter)
 - FN3 = Preset Channel (same as transmitter)
 - FN4 = Monitor / Squelch override
7. Open the data form and in the general tab:
 - In the command mode section disable all check boxes.
 - In the transparent mode section select transparent mode enabled and de-select the other check boxes.
 - Set Power Up State to FFSK transparent mode.
8. Open the data form and in the serial communications tab:
 - In the serial communications setup field set the FFSK transparent mode baud rate to 1200, the Flow control to None and the data port to the required data port.
 - Ensure hardware flow control is set to None.
9. Open the data form RF modems tab. The THSD modem settings do not apply and can be ignored. In the FFSK modem section set up the following:
 - Ignore CTCSS/DCS can be disabled (CTCSS/DCS is not used in this example).
 - Enable Check Packet Length.
 - Disable FFSK Tone Blanking.
 - FFSK Lead-In Delay default of 500ms is suitable but can be changed.
 - FFSK Lead-Out Delay default of 200ms is suitable but can be changed.
10. Program the receiver.

6.5.8 Programming for THSD Operation

- Transmitter**
1. Read the transmitter or start with a new transmitter data file.
 2. Use the reset to defaults command under the file menu to ensure all the mandatory and recommended settings are in their correct default states.
 3. Open the specifications form and select the correct RF band.
 4. Open the channels form summary tab. Add as many channels as are required and for each channel enter the following:
 - transmit frequency
 - Tx subaudible signalling value = Ignored in THSD Mode

- power level
 - bandwidth.
5. Open the channels form details tab and for each channel check the use channel for data check box.
 6. Open the key settings form and select the required function for each function key. For example:
 - FN1 = Preset Channel
 - FN2 = Preset Channel
 - FN3 = Preset Channel
 - FN4 = None
 7. Open the data form and in the general tab:
 - In the command mode section disable all check boxes.
 - In the transparent mode section select transparent mode enabled and THSD modem enabled and de-select the ignore escape sequence check box.
 - Set Power Up State to THSD transparent mode.
 8. Open the data form and in the serial communications tab:
 - In the serial communications setup field set the THSD transparent mode baud rate to 9600, the Flow control to None and the data port to the required data port.



Note Software flow control is not currently supported. The Transmitter's Rx data line is connected to the terminal equipment via the data connector but the transmitter's tx data line is not connected. This means it cannot halt the incoming data flow from the other terminal, which can lead to data loss if data is received from the terminal equipment faster than it can be sent over the air.

- Ensure hardware flow control is set to None.
9. Open the data form RF modems tab. The FFSK modem settings do not apply and can be ignored. In the THSD modem section set up the following:
 - Wide band modem enabled
 - Layer 2 Protocol enabled
 - Forward Error Correction disabled
 - THSD Lead-in Delay default of 30ms is acceptable.
 10. Program the transmitter.

Receiver

1. Read the receiver or start with a new receiver data file.
2. Use the reset to defaults command under the file menu to ensure all the mandatory and recommended settings are in their correct default states.
3. Open the specifications form and select the correct RF band.

4. Open the channels form summary tab. Add as many channels as are required and for each channel enter the following:
 - receive frequency
 - Rx subaudible signalling value = Ignored in THSD Mode
 - squelch setting
 - bandwidth.
 5. Open the channels form details tab and for each channel check the use channel for data check box.
 6. Open the key settings form and select the required function for each function key. For example:
 - FN1 = Preset Channel (same as transmitter)
 - FN2 = Preset Channel (same as transmitter)
 - FN3 = Preset Channel (same as transmitter)
 - FN4 = Monitor / Squelch override.
 7. Open the data form and in the general tab:
 - In the command mode section disable all check boxes.
 - In the transparent mode section select transparent mode enabled and THSD modem enabled and de-select the ignore escape sequence check box.
 - Set Power Up State to THSD transparent mode.
 8. Open the data form and in the serial communications tab:
 - In the serial communications setup field set the THSD transparent mode baud rate to 9600, the Flow control to None and the data port to the required data port.
- Note** Software flow control is not currently supported. The Transmitter's Rx data line is connected to the terminal equipment via the data connector but the transmitter's tx data line is not connected. This means it cannot halt the incoming data flow from the other terminal, which can lead to data loss if data is received from the terminal equipment faster than it can be sent over the air.
- Ensure hardware flow control is set to None.
9. Open the data form RF modems tab. The FFSK modem settings do not apply and can be ignored. In the THSD modem section set up the following:
 - Wide band modem enabled
 - Layer 2 Protocol enabled
 - Forward Error Correction disabled
 - THSD Lead-In Delay default of 30ms is acceptable.
 10. Program the receiver.



6.5.9 Verification

In order to verify the correct operation as an RF modem a basic functional test can be carried out by sending data between the TB7100 base station and a TM8000 mobile radio.

The following equipment will be required:

- DC power supply
- antenna for receiver input
- dummy load for transmitter output
- a PC running the terminal application connected to the serial data port on the base station with a 9-pin serial cable
- a second PC running the terminal application connected to a TM8000 mobile radio which has been programmed to send and receive the required data modulation (FFSK or THSD).

The test setup is shown in “RF modem test setup” on page 84.

Figure 6.8 RF modem test setup

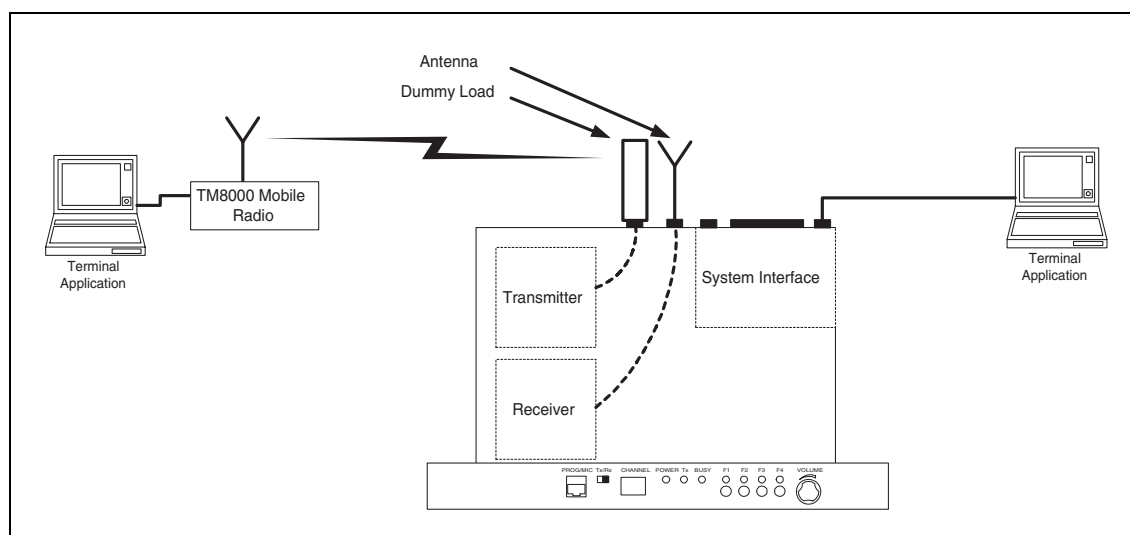

The correct operation of the base station as an RF modem can be verified by transferring text files between the two PCs.

6.6 Data Repeater

In data repeater mode the base station will transmit all valid received data.

Figure 6.9 Data repeater

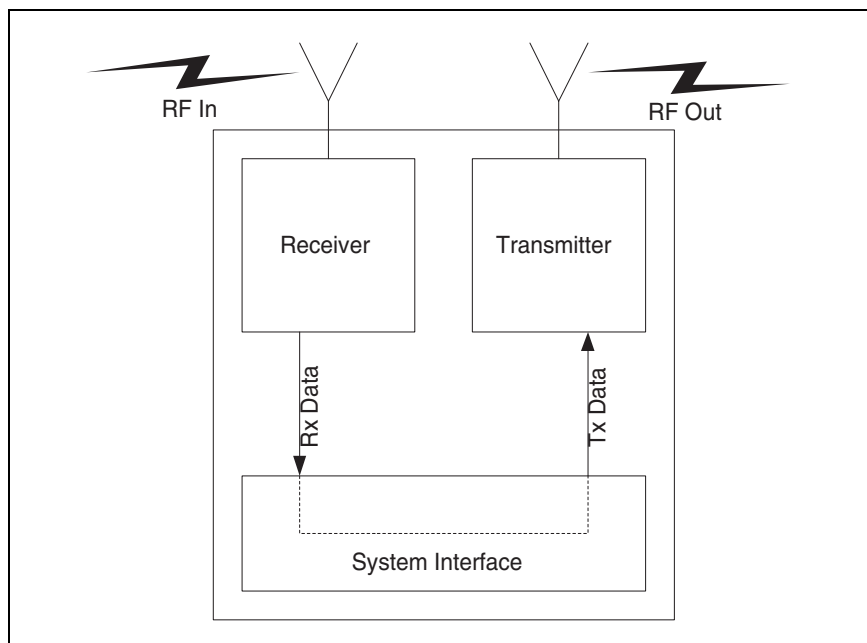

6.6.1 Link Settings

1. Remove the cover as detailed in [“Opening the Base Station” on page 57](#).
2. Set the following links on the SI board.



Note Links of the mandatory settings must be in the position indicated. Links of the optional settings must be in one of the positions listed. The defaults are generally recommended.

3. Fit the cover as detailed in [“Closing the Base Station” on page 58](#).

Table 6.8 Data repeater—mandatory settings

LINK	Name	Pins	Position	Function	Comments
J221	RS232 Loop Back	3	2-3	RS-232 looped back	
J400	Tx Key Source	3	1-2	External Tx key source	Use this setting because the transmitter will automatically key up when there is data to send so should not be keyed by the receiver gate.

Table 6.9 Data repeater—optional settings

LINK	Name	Pins	Position	Function	Comments
J206	Fan Control 1	3	1-2 2-3	Fan controlled by J207 Fan always on	Default position is 1-2
J207	Fan Control 2	3	2-3	Fan temperature-controlled	Do not use position 1-2 (Tx key-activated fan). The transmitter will automatically key up when there is data to send. This will not activate the Tx key line and therefore will not activate the fan.

Figure 6.10 Link positions on the SI board

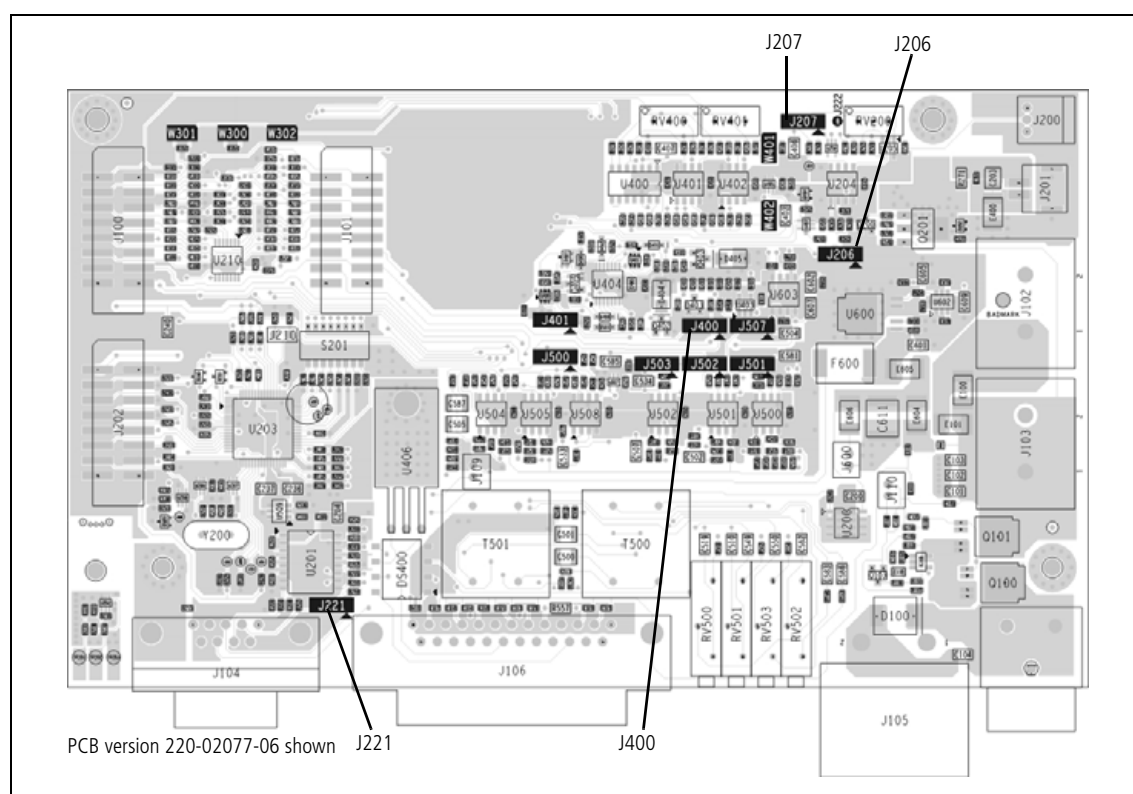

6.6.2 Applying Power

Before turning on the base station, check that:

- all looms and cables at the front and rear of the base station are fitted correctly
- all connectors are secure
- the 20A fuse is fitted.

Turn on the power supply and check that the base station powers up correctly:

- The power LED on the user interface lights up.
- The LCD indicates the current channel number.

6.6.3 Programming

Please see the line-controlled base “[Programming](#)” on page 66 for details on how to program the base station for RF modem operation.

6.6.4 Audio Level Adjustment

In this configuration the system interface connector is not used, so it is not necessary to set the line level or line Sensitivity.

6.6.5 Data Repeater Functional Testing

In order to verify the correct operation as a data repeater a basic functional test can be carried out. This involves sending data from one TM8000 mobile radio to another TM8000 through the TB7100 base station.

The following equipment will be required:

- DC power supply
- antenna for receiver input
- dummy load for transmitter output
- two TM8000 mobile radios capable of sending and receiving the required data format.
- two PCs running the terminal application.
- programming cables for the TM8000 mobile radios.

The test set-up is shown in [Figure 6.11 on page 87](#).

The correct operation of the base station as an RF modem can be verified by transferring text files between the two PCs.

Figure 6.11 Data repeater test setup

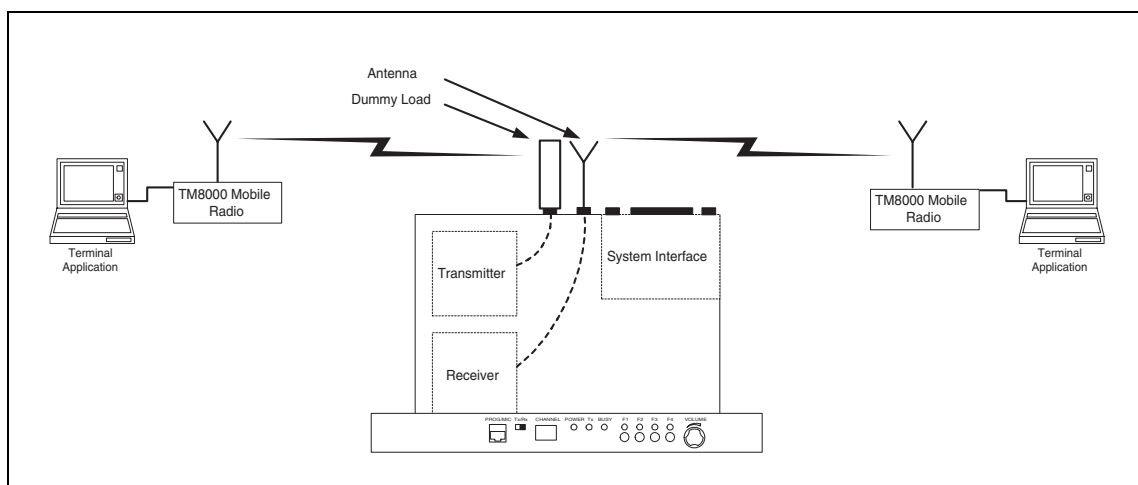

6.7 TaitNet Trunking

The TB7100 base station can be configured to work with a T1810 or T1711 to form part of a TaitNet MPT1327 Trunking System.

For more information, refer to the technical note TN-1033-AN “Using the Tait TB7100 in TaitNet MPT1327 Trunked Networks” available from <http://support.taitworld.com>.

6.8 Programmable Features

The programmable features are applied to the transmitter and receiver modules by using the TB7100 programming application.

6.8.1 Connecting to the PC

1. Plug the TPA-SV-006 or T2000-A19 programming lead into the RS-232 serial port on a PC.



Note A USB-to-RS-232 adaptor can be used if the PC does not have a built in serial port.

2. Connect the TMAA20-04 adaptor cable (RJ12 socket to RJ45 plug) to the RJ12 plug on the TPA-SV-006 or T2000-A19 programming lead.
3. Plug the RJ45 plug on the TMAA20-04 adaptor cable into the PROG/MIC connector located on the front panel of the base station.

Select whether the TB7100 programming application communicates with the transmitter or receiver module by using the receiver/transmitter programming switch located on the user interface next to the PROG/MIC connector.

6.8.2 TB7100 Programming Application

The TB7100 programming application allows the configuration parameters of receiver or transmitter to be read out of a module, edited and written back into the module. It is also possible to save the data files, so if a module ever needs to be replaced, the previously saved data file can be programmed into the new module. The model toolbar, indicates whether the data file is for a receiver or transmitter module.

Appearance

The TB7100 programming application has been optimised for mouse navigation. Most features can be easily enabled and configured using a check box or drop down list and the frequencies for each channel are simply typed into a table.

Feature	Function
Menus	Located along the top of the screen, these allow the user to perform functions such as opening or saving data files, and reading or programming the modules.
Toolbar	Located just below the menu bar, the toolbar allows easy access to the most commonly used menu items.
Radio Model Toolbar	Located just below the toolbar, this indicates whether a newly loaded file type is for a receiver or transmitter module. It also allows the required module type to be selected when a new data file is being created.
Forms Tree	Located on the left side of the screen, the Forms Tree lists all the forms that are available for editing.
Forms	Displayed beside the Forms Tree is the Active Form. The TB7100 programming application is made up of several Forms (a page of parameters). All the configuration parameters related to a particular feature are grouped together in one form. Each form is intuitively labelled and easily accessible from a Forms Tree

Separate Data Files

The base station has separate transmitter and receiver modules, which are independently programmed with their required settings. This means that the base station will have two data files, one for the transmitter and one for the receiver.

New Data Files

The reset to defaults feature in the TB7100 programming application makes it easy to create a new data file. The required module type (receiver or transmitter) is selected by pressing the appropriate button on the radio model toolbar. The reset to defaults feature under the file menu is used to reset all the settings to their default states. This ensures all the mandatory and recommended settings are correct before starting to create a new data file. The customer-specific settings for the current application are entered. Reset to defaults only affects the currently active radio model, so the correct radio model must be selected first. If “reset to defaults” is greyed out, then the settings are already in their default states.

Existing Data Files

An existing data file can be read out of a transmitter or receiver module or loaded from file. The radio model toolbar in the TB7100 programming application will automatically update when a data file is loaded or read out of a module to indicate whether the file is for a receiver or transmitter module. The file can then be edited and saved or programmed back into the module.



Note

It is possible to read the receiver module and then the transmitter module and have both data files loaded at the same time. The radio model toolbar can then be used to toggle between the two data files. When editing is complete, it is important to ensure the receiver/transmitter programming switch position matches the currently active data file before programming the module.

6.8.3 Mandatory Settings

The mandatory settings must not be changed from their default states or the base station will not operate correctly. The mandatory settings in the receiver module are not the same as those in the transmitter module. The reset to defaults feature in the TB7100 programming application will ensure all mandatory settings are correct for the selected module type. The mandatory settings are not locked out. It is possible to change a mandatory setting from its required state.

Receiver Mandatory Settings

The mandatory settings for the receiver are shown below. If these change, the receiver will no longer operate.

Form	Tab	Item Name	Setting
Data	General	Output SDMs Automatically	Disabled
Data	Serial Communications	Data_Port	AUX
Data	Serial Communications	XON_Character	11
Data	Serial Communications	XOFF_Character	13
Basic Settings	Basic Network Settings	TX Timer Duration	1
Basic Settings	Basic Network Settings	TX Lockout Duration	250
Basic Settings	Sub Audible Signalling	CTCSS Lead-Out Delay	0
Basic Settings	Sub Audible Signalling	Invert Tx DCS	Disabled
Basic Settings	Sub Audible Signalling	DCS Lead-Out Delay	0
Channels	Detailed	TX_Frequency	000.000000
Channels	Detailed	TX Sig	none
Channels	Detailed	Power	off
UI Preferences	User Interface	Confidence Tones	Disabled
UI Preferences	User Interface	Silent Mode	Disabled
UI Preferences	Audible Indicators	Enabled	All Disabled
Startup	Startup	Power On Mode	Power on
Startup	Startup	Reset On Error	Enabled
PTT	MIC PTT	PTT Priority	high
PTT	MIC PTT	Audio Source	CH MIC
PTT	External PTT 1	PTT Transmission Type	none
PTT	External PTT 1	PTT Priority	medium
PTT	External PTT 1	Audio Source	CH MIC

Transmitter Mandatory Settings

The mandatory settings for the transmitter are shown below, if these change the transmitter will no longer operate.

Form	Tab	Item Name	Setting
Data	General	Output SDMs Automatically	Disabled
Data	Serial Communications	Data_Port	AUX
Data	Serial Communications	XON_Character	11
Data	Serial Communications	XOFF_Character	13
Basic Settings	Sub Audible Signalling	Invert Rx DCS	Disabled
Channels	Detailed	RX_Frequency	000.000000
Channels	Detailed	RX Sig	none
Channels	Detailed	Squelch	hard
UI Preferences	User Interface	Confidence Tones	Disabled
UI Preferences	User Interface	Silent Mode	Disabled
UI Preferences	Audible Indicators	Enabled	All Disabled
Startup	Startup	Power On Mode	Power on
Startup	Startup	Reset On Error	Enabled
PTT	MIC PTT	PTT Priority	high
PTT	MIC PTT	Audio Source	CH Mic
PTT	External PTT 1	PTT Priority	medium
PTT	External PTT 1	Audio Source	Audio Tap In

6.8.4 User-defined Settings

The user-defined settings are specific to the customers application. These are the only settings that need to be changed when configuring a base station for operation. To set up a basic voice repeater or base station only the channel information needs to be entered:

- frequency
- power level
- bandwidth
- squelch threshold
- sub-audible signalling.

If the system is to be used for data then the data parameters also need to be set correctly:

- baud rate
- flow control
- error correction.

Receiver User-defined Settings

The user-defined settings for the receiver are shown below. The cells in grey denote that the value should stay as detailed because of other constraining settings.

Form	Tab	Item Name	Value Range	Recommended
Data	General	Transparent Mode Enabled	Enabled / Disabled	Enabled
Data	General	THSD_Modem_Enabled	Enabled / Disabled	Enabled
Data	Serial Communications	FFSK_Transparent_Mode_Baudrate	1200, 2400, 4800, 9600, 14400, 19200, 28800	19200
Data	Serial Communications	THSD_Transparent_Mode_Baudrate	1200, 2400, 4800, 9600, 14400, 19200, 28800	19200
Basic Settings	Basic Network Settings	Squelch Detect Type	Noise level, Signal strength	Noise Level
Basic Settings	Sub Audible Signalling	Invert Rx DCS	Enabled, Disabled	Disabled
Channels	Detailed	RX_Frequency	000.000000... 999.999999	Required receive channel frequency
Channels	Detailed	RX Sig	CTCSS tone OR DCS tone	none
Channels	Detailed	Network	1...4	1
Channels	Detailed	Bandwidth	12.5, 20, 25	12.5
Channels	Detailed	Squelch	country, city, hard	city
Channels	Detailed	Use_Channel_For_Data	Enabled, Disabled	Disabled
Key Settings	Key 1	Key Action	see Key Action type	none
Key Settings	Key 2	Key Action	see Key Action type	none
Key Settings	Key 3	Key Action	see Key Action type	none
Key Settings	Key 4	Key Action	see Key Action type	none
UI Preferences	User Interface	Backlight Mode	off, activity, continuous	off
UI Preferences	User Interface	Backlight Duration	0...15	5
PTT	MIC PTT	PTT Transmission Type	none, voice, data	none

Transmitter User-defined Settings

The user-defined settings for the transmitter are shown below. The cells in grey denote that the value should stay as detailed because of other constraining settings

Form	Tab	Item Name	Value Range	Recommended
Data	General	Transparent Mode Enabled	Enabled / Disabled	Enabled
Data	General	THSD_Modem_Enabled	Enabled / Disabled	Enabled
Data	Serial Communications	FFSK_Transparent_Mode_Baudrate	1200, 2400, 4800, 9600, 14400, 19200, 28800	19200
Data	Serial Communications	THSD_Transparent_Mode_Baudrate	1200, 2400, 4800, 9600, 14400, 19200, 28800	19200
Basic Settings	Basic Network Settings	TX Timer Duration	0...250	0
Basic Settings	Basic Network Settings	TX Lockout Duration	0...250	0
Basic Settings	Sub Audible Signalling	CTCSS Lead-Out Delay	0...1000	0
Basic Settings	Sub Audible Signalling	Invert Tx DCS	Enabled, Disabled	Disabled
Basic Settings	Sub Audible Signalling	DCS Lead-Out Delay	0...1000	0
Channels	Detailed	TX_Frequency	000.000000...999.999999	Required transmit channel frequency
Channels	Detailed	TX Sig	CTCSS tone OR DCS tone	none
Channels	Detailed	Power	off, very low, low, medium, high	high
Channels	Detailed	Network	1...4	1
Channels	Detailed	Bandwidth	12.5, 20, 25	12.5
Channels	Detailed	Use_Channel_For_Data	Enabled, Disabled	Disabled
Key Settings	Key 1	Key Action	see Key Action type	none
Key Settings	Key 2	Key Action	see Key Action type	none
Key Settings	Key 3	Key Action	see Key Action type	none
Key Settings	Key 4	Key Action	see Key Action type	none
UI Preferences	User Interface	Backlight Mode	off, activity, continuous	off
UI Preferences	User Interface	Backlight Duration	0...15	5
PTT	MIC PTT	PTT Transmission Type	none, voice, data	Voice
PTT	External PTT 1	PTT Transmission Type	none, voice, data	Voice

Receiver Digital IO

The user-defined settings for the receiver digital IO are shown below. The cells in grey denote mandatory settings.

Pin	Direction	Label	Action	Active	Debounce	Signal State	Mirrored To
AUX_GPI1	Input	BIN_0	No Action	Low	10	None	None
AUX_GPI2	Input	BIN_1	No Action	Low	10	None	None
AUX_GPI3	Input	BIN_2	No Action	Low	10	None	None
AUX_GPI04	Input	BIN_4	No Action	Low	10	None	None
AUX_GPI05	None	RX_DO_1	No Action	Low	None	None	None
AUX_GPI06	None	RX_DO_2	No Action	Low	None	None	None
AUX_GPI07	Output	RXGATE	Busy Status	High	None	None	None

Transmitter Digital IO

The user-defined settings for the transmitter digital IO are shown below. The cells in grey denote mandatory settings.

Pin	Direction	Label	Action	Active	Debounce	Signal State	Mirrored To
AUX_GPI1	Input	BIN_0	No Action	Low	10	None	None
AUX_GPI2	Input	BIN_1	No Action	Low	10	None	None
AUX_GPI3	Input	BIN_2	No Action	Low	10	None	None
AUX_GPI04	Input	BIN_4	No Action	Low	10	None	None
AUX_GPI05	None	TX_DO_1	No Action	Low	None	None	None
AUX_GPI06	None	TX_DO_2	No Action	Low	None	None	None
AUX_GPI07	Input	TXKEY	External PTT 1	High	2	None	None

Receiver Audio

The user-defined settings for the receiver audio IO are shown below. The cells in grey denote mandatory settings.

Rx/PTT Type	Tap In	Tap In Type	Tap In Unmute	Tap Out	Tap Out Type	Tap Out Unmute
Rx	None	A-Bypass In	On PTT	R4	D-Split	Busy detect + Subaud
Mic PTT	None	A-Bypass In	On PTT	None	C-Bypass Out	On PTT
EPTT1	None	A-Bypass In	On PTT	None	C-Bypass Out	On PTT
EPTT2	None	A-Bypass In	On PTT	None	C-Bypass Out	On PTT

Transmitter Audio The user-defined settings for the transmitter audio IO are shown below. The cells in grey denote mandatory settings.

Rx/PTT Type	Tap In	Tap In Type	Tap In Unmute	Tap Out	Tap Out Type	Tap Out Unmute
Rx	None	A-Bypass In	On PTT	None	D-Split	On PTT
Mic PTT	None	A-Bypass In	On PTT	None	C-Bypass Out	On PTT
EPTT1	T8	A-Bypass In	On PTT	None	C-Bypass Out	On PTT
EPTT2	None	A-Bypass In	On PTT	None	C-Bypass Out	On PTT

6.8.5 Recommended Settings

Recommended settings provide system designers with an extra level of flexibility to meet a specific operational requirement. In general, recommended settings should not be changed from the recommended default value. However unlike mandatory settings, the user is permitted to make changes, providing they verify the correct operation of the enabled or modified feature.

No guarantee is given that a feature will work if the recommended settings disable the feature, or if a recommended value is changed.

Although the individual modules are capable of these features, they cannot be fully supported by the base station because of its two-module configuration. A few examples of features that are not fully supported by the base station are:

- selcall
- two tone
- emergency mode
- scanning
- encryption (voice inversion).

The reset to defaults feature in the TB7100 programming application will ensure all recommended settings are in their recommended default state.

Recommended Settings Examples

To explain recommended settings more clearly, two Selcall examples are given below. The first example shows that, although Selcall is not a supported feature of the base station, systems designers have much more flexibility to meet a customer's requirement.

Example One

A customer has a requirement to remotely turn on external lighting at the base station site.

Although Selcall is not a supported feature of the base station, it is likely that enabling Selcall in the receiver could meet this customer's requirement. With Selcall enabled, a control status could be programmed to turn on a

Programmable I/O line. This line could be connected to the lighting control circuit at the site via the system interface connector.

Example Two

The customer also wants an acknowledgement sent back to confirm that the command to turn on the lights was received.

At first the solution would appear to be to enable Selcall auto acknowledgments. However this would not work, because the base station has separate receiver and transmitter modules. The receiver module will decode the selcall and enable the I/O line, but has no method of informing the transmitter to send back an acknowledgment. In fact the receiver module would attempt to transmit the acknowledgment itself, but would be inhibited by other mandatory settings.

6.8.6 Function Keys

The base station also has four user-defined function keys on the user interface, and programmable digital input and output lines on the system connector.

The tables below list the options that can be assigned to the function keys and the digital input and output lines. The grey cells can be programmed but are not recommended (see [“Recommended Settings”](#) on page 95).

Function Key Options	
None	Monitor / Squelch Override
Audible Indicators Volume	Network Preset Calls
Action Digital Output Line	Nuisance Delete
Backlighting Timer	Phone Patch Call Request / Release
Backlighting Toggle	Preset Channel
Backlighting Timer / Toggle	Public Address
Call Cleardown	Quiet Operation
Channel Preset Call	Repeater Access Tone Tx
Emergency Mode	Repeater Talkaround
Encryption	Reset Monitor
Group Scanning Activity	Reset Monitor / Call Cleardown
Ignore Two-Tone	Silent Operation
Keypress Tones Toggle	Single In-Band Tone
Keypress Tones Volume	Squelch Override
Low Power Transmit	Scanning / Nuisance Delete
Monitor	

Digital Input Line Actions	
No Action	Preset Channel
Toggle Stand-by Mode	Mute External Audio Input
Power Sense (Ignition)	Mute Audio Output Path
Enter Emergency Mode	Unmute Audio Output Path
Send Channel Preset Call	Send Mic Audio To Spkr
Send Network Preset Call 1	Force Audio PA On
External PTT 1 and 2	Force Audio PA Off
Inhibit PTT	Simulate F1 to F4 Key
Toggle Tx RF Inhibit	Toggle F1 to F4 Key LED
Decrement Channel	Toggle Alarm Mode
Increment Channel	Activate THSD Modem
Home Channel	RTS Control (DCE)
BCD Pin 0 to 4	

Digital Output Line Actions	
No Action	Signalling Audio Mute Status
Busy Status	SIBT Received
Radio Transmission Status	Monitor Status
Channel Lock Status	Hookswitch Status
Reflect PTT Status	Call Setup Status
External Alert 1 and 2	Control Status Rx (Line 1 to 3)
Public Address Status	Radio Stunned
Serial Data Tx In Progress	F1 to F4 Key Status
Reflect PTT Inhibit Status	FFSK Data Received Status
Reflect THSD Modem Status	CTS Control (DCE)

6.9 Additional Settings

The additional link settings control the following functions:

- subaudible signalling
 - CTCSS (continuous tone controlled squelch system)
 - DCS (digital coded squelch)
- soft off (Tx tail time)
- tone on idle
- fan operation
- channel ID
- relay polarity
- channel increment and decrement by function buttons
- CWID (carrier wave identification).

6.10 Adding Subaudible Signalling

The base station is able to decode one CTCSS or DCS tone per channel. It can also generate one CTCSS or DCS tone per channel. The generated tone can be the same as the received tone or can be a different tone.

6.10.1 Enabling Subaudible Signalling

- Transmitter Module**
1. Read the data file out of the transmitter module.
 2. Open the channels form and select the required tone in the Tx Sig column.
 3. Open the Networks > Basic Settings > Subaudible Signalling tab and configure the subaudible signalling settings (the defaults are suitable for most applications).
 4. Program the new settings into the transmitter.

- Receiver Module**
1. Read the data file out of the receiver module.
 2. Open the channels table and select the required tone in the Rx Sig column.
 3. Open the Networks > Basic Settings > Subaudible Signalling tab and configure the subaudible signalling settings (the defaults are suitable for most applications).
 4. The Rx tap out point in the receiver (Programmable I/O audio tab) must be changed to R5. This means that an incoming tone/code is filtered out by the receiver.
 5. Program the new settings into the receiver.

6.10.2 Testing Subaudible Signalling

Before carrying out these tests, the base station must be configured as a line-controlled base. It must also be connected to the test equipment as described in “Test Equipment Setup” on page 62.

Tx Subaudible Signalling Deviation

1. Set up the test set to measure the modulation level and frequency.
2. Ensure the test set audio output is turned off, or disconnect the CTU audio input from the test set.
3. Activate the Tx Key switch on the CTU.
4. Verify that the measured frequency and deviation of the CTCSS match the programmed settings.



Note If the measured value does not agree with the programmed settings, the transmitter module is either faulty or needs recalibrating.

Rx Subaudible Signalling Decode

1. Connect the balanced audio output from the CTU to the audio input port on the test set.
2. Set up the test set to measure the audio level and distortion.
3. Set the RF signal generator to the correct RF frequency, modulated with a 1kHz audio tone at 60% of full system deviation.
4. Set the RF output level to -70dBm.
5. Verify that the busy LED on the front panel of the base station turns on but the Rx gate LED on the CTU does not turn on, and no audio output is detected from the balanced line output.
6. Modulate the carrier with the required subaudible signalling.
7. Verify that the Rx gate LED on the CTU turns on, and that the 1 kHz audio tone is detected by the test set, and that the measured distortion level is within the receiver specifications.
8. Turn off the subaudible signal and check that the audio output mutes again.



Note If high distortion is measured, it is likely that the subaudible signal is not being filtered out. Verify that the receiver is programmed with the correct audio tap out point.

6.10.3 Multiple Subaudible Tones

The base station cannot decode multiple subaudible tones on a single channel. This can be overcome by two methods:

Method 1

1. Third-party equipment is available that can be connected to the base station to perform the decoding and regeneration of multiple tones.

2. The base station repeater can be configured to simply pass through any subaudible tone.

Method 2

1. The receiver must not be programmed with any subaudible tones in the channel table.
2. The Rx tap out point in the receiver (Programmable I/O audio tab) must be left as the default value of R4. This means that an incoming tone/code is not filtered out by the receiver.
3. The transmitter must be programmed not to generate any subaudible tones.
4. The Tx Tap In point in the transmitter (Programmable I/O audio tab) must be left as the default value of T8. This means that an incoming tone/code is not filtered out by the transmitter and will be re-transmitted.

Potential Problems

1. The Rx gate may close before end of reverse tone burst (RTB). This means the re-transmitted RTB may be shorter than incoming RTB. A Tx tail (soft off) should be added to overcome this.
2. There is no security for repeaters, as any on-frequency transmission will be repeated, even if it has no subaudible tone.

6.11 Soft Off (Tx Tail Time)

New Firmware (with or without subaudible signalling)

For systems with firmware version 2.10.00.07 (or later) and TB7100 programming application version 1.10.00.0001 (or later):

- Enter a delay time between 0 (default) and 5000ms in the PTT Deactivation Delay field of the PTT > Ext. PTT 1 tab.

Older Firmware (with subaudible signalling)

For systems with firmware versions before 2.10.00.07 and TB7100 programming application versions before 1.10.00.0001:

If subaudible signalling is used:

- Add a Tx tail time using the Networks > Basic Settings > Subaudible Signalling tab. A lead-out delay can be entered in the appropriate field.

Older Firmware (without subaudible signalling)

If subaudible signalling is not used, adding a lead-out delay will have no effect. If soft-off operation is still required, create a Tx tail time as follows:

1. Remove the cover as detailed in [“Opening the Base Station” on page 57](#).
2. Link AUX_GPIO6 and AUX_GPIO7 of the transmitter with link W302 on the SI board, as per [Table 6.10](#). Refer to [Figure 6.12 on page 101](#) for link locations.

3. Fit the cover as detailed in “Closing the Base Station” on page 58.

Table 6.10 Soft off - link settings

LINK	Name	Pins	Position	Function	Comments
W302	TX_Key to TX_GPIO6 link	2	Fitted Not fitted	When fitted this allows two external PTTs to control the transmitter; used for soft off mode	Default is fitted

4. Add the following to the default Tx configuration:
 - AUX_GPIO6 > Direction = input
 - AUX_GPIO6 > Action = External PTT 2
 - AUX_GPIO6 > Active = High
 - AUX_GPIO6 > Debounce = 200 (or smaller if desired)
 - External PTT (2) > Transmission Type = Voice
 - External PTT (2) > Audio Source = Aux Mic or Ch Mic (whichever is not being used)



Note A maximum of 200ms tail time can be achieved using this method.

Figure 6.12 Link positions on the SI board

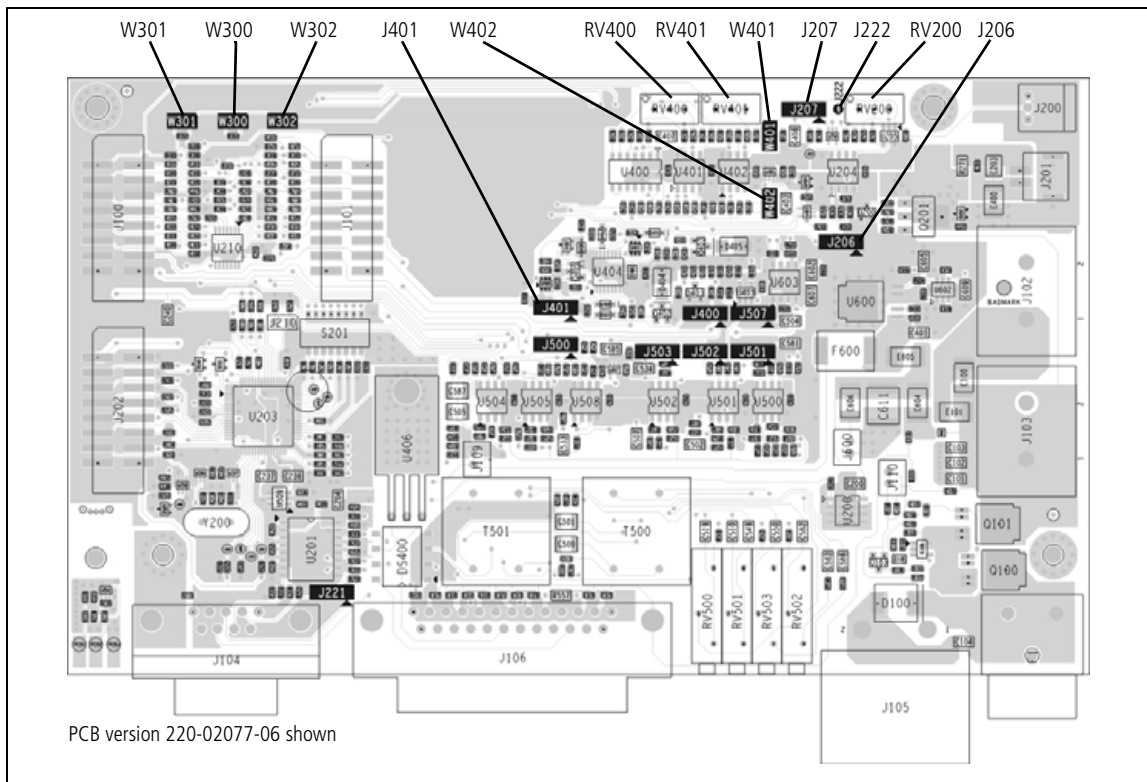

6.12 Tone On Idle (TOI)

The tone on idle provides a tone that can be used for indicating when the base station is not transmitting or receiving. The links to enable or disable the tone on idle are shown in the table below. Both links must be in for the TOI to work.

Link Settings

1. Remove the cover as detailed in [“Opening the Base Station” on page 57](#).
2. Set the jumper positions on the SI board to match [Table 6.11](#). Refer to [Figure 6.12 on page 101](#) for link locations.
3. Fit the cover as detailed in [“Closing the Base Station” on page 58](#).

Table 6.11 Tone on idle (TOI)—link settings

LINK	Name	Pins	Position	Function	Comments
W401	TOI 9V Enable	2	Fitted Not fitted	Tone on Idle enable Tone on Idle disable	Default is fitted
W402	TOI 4.5V Enable	2	Fitted Not fitted	Tone on Idle oscillator enable Tone on Idle oscillator disable	Default is fitted

The potentiometers for the tone on idle adjustments shown in the table below can be found on the SI board. Refer to [Figure 6.12 on page 101](#) for the potentiometer location.

Potentiometer	Function
RV400	Frequency adjust
RV401	level adjust

6.13 Fan Operation

The fans can be made to operate in three modes:

- continuous
- on when base station transmits
- on at a set temperature.

The fan operation can be set as shown in the table below.

Link Settings

1. Remove the cover as detailed in [“Opening the Base Station” on page 57](#).
2. Set the jumper positions on the SI board to match [Table 6.12](#). Refer to [Figure 6.12 on page 101](#) for link locations.
3. Fit the cover as detailed in [“Closing the Base Station” on page 58](#).

Table 6.12 Fan operation—link settings

LINK	Name	Pins	Position	Function	Comments
J206	Fan Control 1	3	1-2 2-3	Fans controlled by J207 Fans always on	Default position is 1-2
J207	Fan Control 2	3	1-2 2-3	Fans Tx key-controlled Fans temperature-controlled	Default position is 2-3

The temperature threshold is set at the factory to 40°C. The potentiometer and test point to adjust the temperature threshold can be found on the SI board. Refer to [Figure 6.12 on page 101](#) for the location.

Designator	Function
RV200	temperature threshold adjust
J222	test point for temperature threshold

When adjusting the temperature threshold the fans must be off. The temperature threshold to voltage relationship is shown in [Figure 6.13 on page 104](#).

Figure 6.13 temperature threshold-to-voltage relationship (RV200 and test point J222)

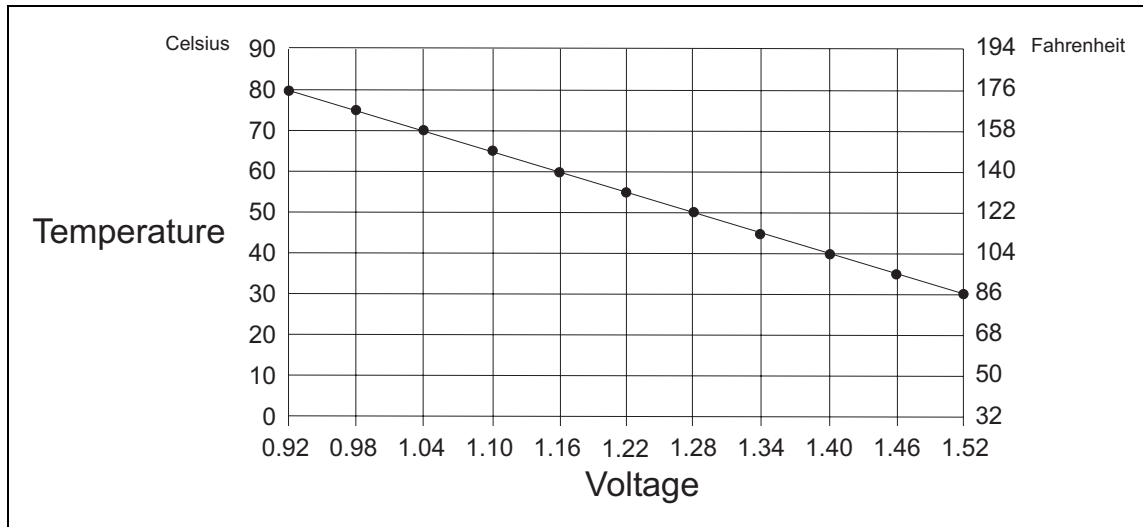

Important

When using THSD and the user interface PTT, the fan setting should be temperature-controlled or always on. This is because the user interface PTT line does not toggle the Tx-key line on the system interface and the THSD is only on for short burst of time never allowing the fan time to spin up.

6.14 External Channel Selection

Channels can be selected externally using the digital I/O lines. This can be enabled using the TB7100 programming application and the links as below.

Link Settings

1. Remove the cover as detailed in [“Opening the Base Station” on page 57.](#)
2. Set the jumper positions on the SI board to match [Table 6.13.](#) Refer to [Figure 6.12 on page 101](#) for link locations.
3. Fit the cover as detailed in [“Closing the Base Station” on page 58.](#)

Table 6.13 External channel selection—link settings

LINK	Name	Pins	Position	Function	Comments
W300		2	Fitted Not fitted	When fitted this allows both transmit and receive modules to be controlled by the same external digital IO lines, used for BCD; used with W301	Default: Not fitted
W301		2	Fitted Not fitted	When fitted this allows both transmit and receive modules to be controlled by the same external digital IO lines; used with W300	Default: Not fitted

When Tx/Rx digital input 1-4 are used for channel selection only 16 binary or 10 BCD channels are available.

When Tx/Rx digital input 1-4 and another line, made from the shorting of Tx digital in/out 1 and Rx digital in/out 1 on the system interface connector are used then a total of 32 binary or 20 BCD channels are selectable. Requires link W300 to be fitted.

6.15 Relay Polarity

Relay operation can be configured to be energised when the receiver gate is active or inactive.

- Link Settings**
1. Remove the cover as detailed in [“Opening the Base Station” on page 57](#).
 2. Set the jumper positions on the SI board to match [Table 6.14](#). Refer to [Figure 6.12 on page 101](#) for link locations.
 3. Fit the cover as detailed in [“Closing the Base Station” on page 58](#).

Table 6.14 Relay polarity—link settings

LINK	Name	Pins	Position	Function	Comments
J401	Relay Polarity Control	3	1-2 2-3	Energised for receiver active gate Energised for receiver inactive gate	Default is 1-2

6.16 Channel Increment and Decrement by Function Keys

Function button one and two can be configured to increment and decrement the channels. This requires two links fitted to the rear of the user interface board, this will hard wire the F1 and F2 buttons to the increment/decrement function. It is recommended F1 & F2 have no other programmed action.

This option will allow all 99 channels to be selected from the function buttons.

For more information, refer to the technical note TN-1032-AN “Implementing Channel Increment and Decrement on the TB7100” available from <http://support.taitworld.com>.

6.17 Continuous Wave Identification (CWID)

CWID (Continuous Wave Identification) is a method of identifying transmitters by automatically transmitting a radio’s call sign in morse code at present intervals. For more information refer to the online help of the TB7100 programming application.

6.18 Configuring F1 and F2

The UI board can be configured to use the F1 and F2 keys to increment and decrement the channel. If the UI board is configured in this way, F1 and F2 can no longer be programmed using the TB7100 programming application.

7 Maintenance Guide

The base station is designed to be very reliable and should require little maintenance. However, performing regular checks will prolong the life of the equipment and prevent problems from happening.

It is beyond the scope of this manual to list every check that you should perform on your base station. The type and frequency of maintenance checks will depend on the location and type of your system. The checks and procedures listed below can be used as a starting point for your maintenance schedule.

Performance Checks We suggest you monitor the following operational parameters:

- VSWR
- DC input voltage, especially on transmit
- receiver sensitivity
- the setting of the receiver gate opening
- transmit deviation

These basic checks will provide an overview of how well your base station is operating.

Receiver There are no special maintenance requirements for the receiver.

Transmitter There are no special maintenance requirements for the transmitter.

System Interface There are no special maintenance requirements for the System interface.

Ventilation The base station has been designed to have a front-to-back cooling airflow. We strongly recommend that you periodically check and maintain the ventilation requirements described in [“Ventilation” on page 38](#) to ensure a long life and trouble-free operation for your base station.

Cooling Fans The cooling fans have a long service life and have no special maintenance requirements.

Battery If you are using battery, you should check the batteries regularly in accordance with the manufacturer’s recommendations.

Glossary

This glossary contains an alphabetical list of terms and abbreviations related to the TB7100 base station. For information about trunking, mobile, or portable terms, consult the glossary provided with the relevant documentation.

A

- accessory** An accessory is an ancillary device fitted externally to a base station, such as an external microphone.
- active** The digital outputs can be programmed to be active high or low when the selected action is true. The digital inputs can be programmed to be active high or low for a selected action. All base station digital outputs are open collector.
- ADC** Analog-to-Digital Converter. A device for converting an analog signal to a digital signal that represents the same information.
- anti-kerchunking** Anti-kerchunking is a base station feature that discourages users from “pinging” (kerchunking) the repeater with short bursts of RF.
- audible indicators** The radio’s audible indicators are used in combination with visual indicators to provide feedback to the radio user. Types of audible indicators are incoming call tones, warning tones, confirmation tones, keypress confidence tones and signalling sidetones.

B

- backlighting** The radio’s display or keypad lights up when there is activity on the radio, such as when a key is pressed or when a call is received. The value of the backlighting timer and how backlighting was activated determine how long backlighting remains on.
- backlighting timer** The backlighting timer determines how long backlighting remains on once it is activated.

balanced line	A balanced line has two wires carrying equal and opposite signals. It is typically used in a line-connected base station for connecting to the despatcher console. The system interface identifies the balanced line out as Rx line output + and Rx line output -, and the balanced line in as Tx line input + and Tx line input -.
base station	A base station is a tray containing transmitter, receiver and system interface modules.
BCD	BCD (binary coded decimal) is a code in which a string of four binary digits represents a decimal number.
birdie	A birdie is a desensitised channel caused by internal interference. A birdie can be eliminated by activating a birdie killer on the channel.
birdie killer	A birdie killer is an internal circuitry switch that greatly reduces the effect of a birdie on a channel.
brownout	A dip in the supply voltage sufficient to put the control section into hardware reset.
C	
Calibration Application	The Calibration Application is a utility for calibrating various parts of the receiver and transmitter circuitry.
channel	A channel is a frequency pair (or just a single frequency in a simplex system). Note: Different channels may have identical frequencies, while other operating parameters may be different.
channel spacing	Channel spacing is the frequency difference between adjacent channels.
channel table	The channel table is the base station's database of channel configurations.
city squelch	When a radio's noise mute threshold is programmed for city squelch, the radio is less sensitive to interference than if programmed for country squelch and so stronger signals are required for the radio's speaker to unmute. City squelch is also known as local squelch.
CODEC	An IC which combines analog-to-digital conversion (coding) and digital-to-analog conversion (decoding).
configuration file	A configuration file consists of all the configuration settings needed for a base station, stored as a file in the configurations folder. Configuration files have the extension *.t7p. The TB7100 uses two files, one for the receiver and one for the transmitter.

country squelch	When a radio's squelch threshold is programmed for country squelch, the radio is more sensitive than if programmed for city squelch and so the radio's speaker unmutes more readily. When programmed for country squelch, the radio can be used in areas where the signal may be weak and where maximum range is desirable. Country squelch is also known as distant squelch.
CTCSS	CTCSS (continuous tone controlled squelch system), also known as PL (private line), is a type of signalling that uses subaudible tones to segregate groups of users.
CTCSS/DCS filter	The CTCSS/DCS filter removes any CTCSS or DCS tones that may be present on the received audio. The filter limits the range of frequencies the radio passes from the incoming signal to the speaker and so in some situations affects signal quality. Filtering can be automatically switched off for channels that do not have CTCSS or DCS.
CTU	A Calibration Test Unit (CTU) is a device used to assist in making testing and calibration of the TB7100 easier.
CWID	CWID (Continuous Wave Identification) is a method of automatically identifying the base station using a Morse code.
D	
DAC	Digital-to-Analog Converter. A device for converting a digital signal to an analog signal that represents the same information.
DCS	DCS (digital coded squelch), also known as DPL (digital private line), is a type of subaudible signalling used for segregating groups of users. DCS codes are identified by a three-digit octal number, which forms part of the continuously repeating code word. When assigning DCS signalling for a channel, you specify the three-digit code.
de-emphasis	De-emphasis is a filtering process in the receiver that attenuates higher frequency audio. It restores pre-emphasised audio to its original relative proportions.
digital signal processor	The device in a radio that analyses and processes signals in the digital domain. Also known as DSP.
Duplexer	A duplexer is a device for connecting one antenna to a transmitter and receiver at the same time.
duty cycle	Duty cycle is used in relation to the transmitter. It is the proportion of time (expressed as a percentage) during which the transmitter is keyed. The transmitter can be operated continuously.

E

- EIA** Electronic Industries Alliance. Accredited by the American National Standards Institute (ANSI) and responsible for developing telecommunications and electronics standards in the USA.
- EMC** Electromagnetic Compatibility. The ability of equipment to operate in its electromagnetic environment without creating interference with other devices or being susceptible to disturbance in the presence of other equipment.
- ETSI** European Telecommunications Standards Institute. The non-profit organisation responsible for producing European telecommunications standards.

F

- FFSK** FFSK (fast frequency shift keying). In Trunking applications this is the method by which code words are sent over the control channel. In 1200 baud FFSK, a 1200 Hz tone represents a zero and an 1800 Hz tone represents a one.
- five-tone** Five-tone is another term for Selcall.
- frequency band** The range of frequencies that the equipment is capable of operating on.
- front panel** The part of the chassis that has the user interface on it.
- Full Duplex** Full duplex is the action of receiving and transmitting at the same time.
- function key** A function key is a key on a radio or radio accessory that can have functions assigned to it.

G

- gating** Gating is the process of opening and closing the receiver audio path. When a valid signal is received, the receiver audio path opens.
- GPIO** General Purpose Input Output (GPIO) lines are used on the TB7100 to configure it for different modes.

H

- hysteresis** Hysteresis is the difference between the upper and lower trigger points. For example, the receiver gate opens when the upper trigger point is reached, but will not close until the level falls to the lower trigger point. An adequate

hysteresis prevents the receiver gate from repeatedly opening and closing when the level is about that of the trigger point.

I

- idle** The state of the radio in trunked mode when it is not engaged in a call or call setup, or in conventional mode when the radio is not transmitting.
- inactive** Digital outputs are inactive if the base station is doing nothing to them. They are floating, open collector outputs. Digital inputs are inactive when they are open circuit.
- indicator** Indicators provide feedback to the radio user on how the current operation is proceeding and on the operating state of the radio. For example, keypress confidence tones are the tones heard when a keypad key or a function key is pressed and tell the user that an action is permitted. Tait radios use combinations of audible indicators and visual indicators.
- inhibit** Prevents the radio state changing.
- isolator** An isolator is a passive two-port device which transmits power in one direction, and absorbs power in the other direction. It is used in a PA to prevent damage to the RF circuitry from high reverse power, and reduces the generation of spurious product due to the ingress of signals from other transmitters.

K

- kerchunking** Kerchunking is transmitting for a second or less without saying anything in order to test the base station. This results in a 'kerchunk' sound.
- keypress confidence tone** A keypress confidence tone is a type of audible indicators given each time the user presses a key to confirm that the action selected is valid.

L

- LCD** A Liquid Crystal Display (LCD) is used on the TB7100 user interface to display channel number.
- line-controlled base station** A TB7100 is a line-controlled base station when it receives audio (sending it out via its systems interface), transmits audio received over its systems interface, and its transmitter is keyed via the Tx Key line.
- local squelch** See city squelch.

M

Mandatory Settings	The mandatory settings are settings in the programming application that must not be changed from their default states or the TB7100 will not operate correctly. The Mandatory Settings in the receiver module are not the same as those in the transmitter module.
multi-tone	Multi-tone is another term for Selcall.
mute	A mute controls the circumstances under which a received signal is passed to the radio's audio output. When a mute is active, the radio's speaker audio path opens under certain conditions, determined by the type of signalling operating on a channel and the noise mute threshold.

N

noise mute	The noise mute feature ensures that the radio's speaker only unmutes when an intelligible signal is received. A signal is considered intelligible when it is strong enough to exceed a predetermined noise mute threshold.
noise mute threshold	The noise mute threshold is the level the signal must reach before it is regarded as intelligible and the radio's mute is opened.

P

PA	The PA (power amplifier) is a part of the transmitter that boosts the exciter output to a certain level sufficient to transmit via the antenna.
power down	Radio is switched off.
power up	Radio is switched on.
pre-emphasis	Pre-emphasis is a process in the transmitter that boosts higher audio frequencies.
programming	manipulating calibration database, radio database.
Programming Application	The programming application is used to create configuration files for the base station. The programming application can read files from the base station or load new files onto the base station.
programming database	The programming database is the information that is altered using the radio programming application.
programming mode	The mode of operation of the radio in which computer equipment can read from and write to the radio database.

Q

- quiet operation** When quiet operation is active, all audible indicators except incoming call alerts, sidetones and warning tones are disabled. Contrast with silent operation.
- quiet state** The quiet state is the state the radio is in when monitor is inactive the radio user does not have to listen to traffic that is not intended for them.

R

- Recommended Settings** Recommended settings are settings in the programming application that should not be changed from the recommended default value, but unlike mandatory settings, the user is permitted to make changes; providing they verify the correct operation of the enabled or modified feature. No guarantee is given that a feature will work if the recommended settings disable the feature or if a recommended value is changed.
- repeater** A repeater receives a radio signal and re-transmits it. Use of a repeater increases the coverage area of a two-way radio system and ensures more reliable performance in areas where signals are reflected or attenuated by buildings or terrain.
In a repeater-based system, the radio's transmit frequency is the frequency the repeater is listening on, and the radio's receive frequency is the frequency the repeater re-broadcasts signals on.
- reverse tone burst** Reverse tone bursts (RTB) can be used with CTCSS. When reverse tone bursts are enabled, the phase of the generated tones is reversed for a number of cycles just before transmission ceases. If the receiver is configured for reverse tone burst, it responds by closing its gate faster than if the RTB were not transmitted.
- RF** RF stands for radio frequency and refers to the part of the electromagnetic spectrum used to transmit radio and television signals.
- RSSI** RSSI (Received Signal Strength Indicator) feature that indicates the strength of the received signal.
- Rx** Rx is an abbreviation for receive or receiver.

S

- Selcall** Selcall stands for "selective calling", which is a signalling system that uses sequences of audible tones to isolate calls intended for specific radios. Each radio operating on a Selcall network can have a unique identity assigned. Selcall is sometimes called multi-tone or five-tone.

sensitivity	The sensitivity of a radio receiver is the minimum input signal strength required to provide a useable output.
signalling	Non-voice coding on the channel for the purpose of identifying parties and/or segregating user groups, e.g. CTCSS, DCS, DTME, Selcall, two-tone.
signalling mute	When the signalling mute is enabled, the radio only unmutes when a valid Selcall or two tone identity is received.
SINAD	SINAD (Signal plus Noise and Distortion) is a measure of signal quality. It is the ratio of (signal + noise + distortion) to (noise + distortion). A SINAD of 12dB corresponds to a signal to noise voltage ratio of 4:1.
subaudible signalling	Subaudible signalling is signalling that is at the bottom end of the range of audible frequencies. The base station supports CTCSS and DCS subaudible signalling.
subtone	A subtone (subaudible signalling tone) is a CTCSS tone or a DCS code.
switching range	The switching range is the range of frequencies that the equipment is tuned to operate on.
system interface	The system interface is the set of inputs to and outputs from the base station (excluding RF), provided by a module inside the tray.

T

TB7100 Base Station	A TB7100 base station consists of the equipment necessary to receive and transmit on one channel. Generally, this means receiver, transmitter and system interface modules. Often abbreviated to TB7100 or base station.
TCXO	Temperature compensated crystal oscillator (voltage controlled). The frequency reference for the RF part of the radio.
Talk Through Repeater	A TB7100 is a talk through repeater when its audio path is configured to pass the audio it receives on to the transmitter, and its receiver gate signal is configured to key the transmitter.
THSD	Tait High Speed Data (THSD) is a proprietary data protocol. THSD uses a four level frequency shift keying modulation scheme.
toggle	The term toggle is used to describe the switching between two states.
tone	A tone is an audio signal of a particular frequency.
TOI	Tone On Idle (TOI) is an audio tone used on the receiver output to indicate when the base station is idle.

transmit (Tx) frequency The transmit frequency is the frequency that all outgoing transmissions are made on.

transmit lockout The transmit lockout feature prevents the base station from transmitting for a time once the transmit timer has expired.

Tx Tx is an abbreviation for transmit or transmitter.

U

unbalanced line An unbalanced line has one wire earthed. It is typically used for short connections, for example, between a base station and a repeater on the same site. The system interface identifies the wires of unbalanced lines with Rx audio output, Tx audio input, and Ground.

User Defined Settings The User Defined Settings are settings in the programming application that are specific to the customers application. These are the only settings that need to be changed when configuring a TB7100 for operation.

user interface The user interface panel is an area at the front of the base station with buttons, LEDs and other controls that let you interact with the base station.

V

valid signal A valid signal is a signal that the receiver responds to by opening the receiver gate. A signal is valid for example when it is stronger than a minimum level and when it has the specified subtone.

visual indicator The term “visual indicator” refers to a visual cue the radio gives to provide feedback to the user. Visual indicators are used in combination with audible indicators. Visual indicators include LEDs and LCD display text.

VSWR Voltage Standing Wave Ratio (VSWR) is the ratio of the maximum peak voltage anywhere on the line to the minimum value anywhere on the line. A perfectly matched line has a VSWR of 1:1. A high ratio indicates that the antenna subsystem is poorly matched.

W

Watchdog A watchdog circuit checks that the system is still responding. If the system does not respond (because the firmware has locked up), the circuit resets the system.

Tait General Software Licence Agreement

This legal document is an Agreement between you (the “Licensee”) and Tait Electronics Limited (“Tait”). By using any of the Software or Firmware items prior-installed in the related Tait product, included on CD or downloaded from the Tait website, (hereinafter referred to as “the Software or Firmware”) you agree to be bound by the terms of this Agreement. If you do not agree to the terms of this Agreement, do not install and use any of the Software or Firmware. If you install and use any of the Software or Firmware that will be deemed to be acceptance of the terms of this licence agreement.

The terms of this Agreement shall apply subject only to any express written terms of agreement to the contrary between Tait and the Licensee.

Licence

TAIT GRANTS TO YOU AS LICENSEE THE NON-EXCLUSIVE RIGHT TO USE THE SOFTWARE OR FIRMWARE ON A SINGLE MACHINE PROVIDED YOU MAY ONLY:

1. COPY THE SOFTWARE OR FIRMWARE INTO ANY MACHINE READABLE OR PRINTED FORM FOR BACKUP PURPOSES IN SUPPORT OF YOUR USE OF THE PROGRAM ON THE SINGLE MACHINE (CERTAIN PROGRAMS, HOWEVER, MAY INCLUDE MECHANISMS TO LIMIT OR INHIBIT COPYING, THEY ARE MARKED “COPY PROTECTED”), PROVIDED THE COPYRIGHT NOTICE MUST BE REPRODUCED AND INCLUDED ON ANY SUCH COPY OF THE SOFTWARE OR FIRMWARE; AND / OR
2. MERGE IT INTO ANOTHER PROGRAM FOR YOUR USE ON THE SINGLE MACHINE (ANY PORTION OF ANY SOFTWARE OR FIRMWARE MERGED INTO ANOTHER PROGRAM WILL CONTINUE TO BE SUBJECT TO THE TERMS AND CONDITIONS OF THIS AGREEMENT).

THE LICENSEE MAY NOT DUPLICATE, MODIFY, REVERSE COMPILE OR REVERSE ASSEMBLE ANY SOFTWARE OR FIRMWARE IN WHOLE OR PART.

Important Notice

THE SOFTWARE OR FIRMWARE MAY CONTAIN OPEN SOURCE SOFTWARE COMPONENTS (“OPEN SOURCE COMPONENTS”). OPEN SOURCE COMPONENTS ARE EXCLUDED FROM THE TERMS OF THIS AGREEMENT EXCEPT AS EXPRESSLY STATED IN THIS AGREEMENT AND ARE COVERED BY THE TERMS OF THEIR RESPECTIVE LICENCES WHICH MAY EXCLUDE OR LIMIT ANY WARRANTY FROM OR LIABILITY OF THE DEVELOPERS AND/OR COPYRIGHT HOLDERS OF THE OPEN SOURCE COMPONENT FOR THE PERFORMANCE OF THOSE OPEN SOURCE COMPONENTS. YOU AGREE TO BE BOUND BY THE TERMS AND CONDITIONS OF EACH SUCH LICENCE. FOR MORE INFORMATION SEE: <http://support.taitworld.com/go/opensource>

Title to Software

THIS AGREEMENT DOES NOT CONSTITUTE A CONTRACT OF SALE IN RELATION TO THE SOFTWARE OR FIRMWARE SUPPLIED TO THE LICENSEE. NOT WITHSTANDING THE LICENSEE MAY OWN THE MAGNETIC OR OTHER PHYSICAL MEDIA ON WHICH THE SOFTWARE OR FIRMWARE WAS ORIGINALLY SUPPLIED, OR HAS SUBSEQUENTLY BEEN RECORDED OR FIXED, IT IS A FUNDAMENTAL TERM OF THIS AGREEMENT THAT AT ALL TIMES TITLE AND OWNERSHIP OF THE SOFTWARE OR FIRMWARE, WHETHER ON THE ORIGINAL MEDIA OR OTHERWISE, SHALL REMAIN VESTED IN TAIT OR THIRD PARTIES WHO HAVE GRANTED LICENCES TO TAIT.

Term and Termination

THIS LICENCE SHALL BE EFFECTIVE UNTIL TERMINATED IN ACCORDANCE WITH THE PROVISIONS OF THIS AGREEMENT. THE LICENSEE MAY TERMINATE THIS LICENCE AT ANY TIME BY DESTROYING ALL COPIES OF THE SOFTWARE OR FIRMWARE AND ASSOCIATED WRITTEN MATERIALS. THIS LICENCE WILL BE TERMINATED AUTOMATICALLY AND WITHOUT NOTICE FROM TAIT IN THE EVENT THAT THE LICENSEE FAILS TO COMPLY WITH ANY TERM OR CONDITION OF THIS AGREEMENT. THE LICENSEE AGREES TO DESTROY ALL COPIES OF THE SOFTWARE OR FIRMWARE AND ASSOCIATED WRITTEN MATERIALS IN THE EVENT OF SUCH TERMINATION.

Limited Warranty

THE SOFTWARE OR FIRMWARE (INCLUDING OPEN SOURCE COMPONENTS) IS SUPPLIED BY TAIT AND ACCEPTED BY THE LICENSEE "AS IS" WITHOUT WARRANTY OF ANY KIND EITHER EXPRESSED OR IMPLIED, INCLUDING BUT NOT BEING LIMITED TO ANY IMPLIED WARRANTIES AS TO MERCHANTABILITY OR FITNESS FOR ANY PARTICULAR PURPOSE. THE LICENSEE ACKNOWLEDGES THAT THE SOFTWARE OR FIRMWARE (INCLUDING OPEN SOURCE COMPONENTS) IS USED BY IT IN BUSINESS AND ACCORDINGLY TO THE MAXIMUM EXTENT PERMITTED BY LAW NO TERMS OR WARRANTIES WHICH ARE IMPLIED BY LEGISLATION SHALL APPLY TO THIS AGREEMENT. TAIT DOES NOT WARRANT THAT THE FUNCTIONS CONTAINED IN THE SOFTWARE OR FIRMWARE (INCLUDING OPEN SOURCE COMPONENTS) WILL MEET THE LICENSEE'S REQUIREMENTS OR THAT THE OPERATION OF THE SOFTWARE OR FIRMWARE (INCLUDING OPEN SOURCE COMPONENTS) WILL BE UNINTERRUPTED OR ERROR FREE.

Exclusion of Liability

IN NO CIRCUMSTANCES SHALL TAIT BE UNDER ANY LIABILITY TO THE LICENSEE, OR ANY OTHER PERSON WHATSOEVER, WHETHER IN TORT (INCLUDING NEGLIGENCE), CONTRACT (EXCEPT AS EXPRESSLY PROVIDED IN THIS AGREEMENT), EQUITY, UNDER ANY STATUTE, OR OTHERWISE AT LAW FOR ANY LOSSES OR DAMAGES WHETHER GENERAL, SPECIAL, EXEMPLARY, PUNITIVE, DIRECT, INDIRECT OR CONSEQUENTIAL ARISING OUT OF OR IN CONNECTION WITH ANY USE OR INABILITY OF USING THE SOFTWARE OR FIRMWARE (INCLUDING OPEN SOURCE COMPONENTS).

THE LICENSEE'S SOLE REMEDY AGAINST TAIT WILL BE LIMITED TO BREACH OF CONTRACT AND TAIT'S SOLE AND TOTAL LIABILITY FOR ANY SUCH CLAIM SHALL BE LIMITED AT THE OPTION OF TAIT TO THE REPAIR OR REPLACEMENT OF THE SOFTWARE OR FIRMWARE OR THE REFUND OF THE PURCHASE PRICE OF THE SOFTWARE OR FIRMWARE.

General

THE LICENSEE CONFIRMS THAT IT SHALL COMPLY WITH THE PROVISIONS OF LAW IN RELATION TO THE SOFTWARE OR FIRMWARE.

Law and Jurisdiction

THIS AGREEMENT SHALL BE SUBJECT TO AND CONSTRUED IN ACCORDANCE WITH NEW ZEALAND LAW AND DISPUTES BETWEEN THE PARTIES CONCERNING THE PROVISIONS HEREOF SHALL BE DETERMINED BY THE NEW ZEALAND COURTS OF LAW. PROVIDED HOWEVER TAIT MAY AT ITS ELECTION BRING PROCEEDINGS FOR BREACH OF THE TERMS HEREOF OR FOR THE ENFORCEMENT OF ANY JUDGEMENT IN RELATION TO A BREACH OF THE TERMS HEREOF IN ANY JURISDICTION TAIT CONSIDERS FIT FOR THE PURPOSE OF ENSURING COMPLIANCE WITH THE TERMS HEREOF OR OBTAINING RELIEF FOR BREACH OF THE TERMS HEREOF.

No Dealings

THE LICENSEE MAY NOT SUBLICENSE, ASSIGN OR TRANSFER THE LICENCE OR THE PROGRAM EXCEPT AS EXPRESSLY PROVIDED IN THIS AGREEMENT. ANY ATTEMPT OTHERWISE TO SUBLICENSE, ASSIGN OR TRANSFER ANY OF THE RIGHTS, DUTIES OR OBLIGATIONS HEREUNDER IS VOID.

No Other Terms

THE LICENSEE ACKNOWLEDGES THAT IT HAS READ THIS AGREEMENT, UNDERSTANDS IT AND AGREES TO BE BOUND BY ITS TERMS AND CONDITIONS. THE LICENSEE FURTHER AGREES THAT SUBJECT ONLY TO ANY EXPRESS WRITTEN TERMS OF AGREEMENT TO THE CONTRARY BETWEEN TAIT AND THE LICENSEE THIS IS THE COMPLETE AND EXCLUSIVE STATEMENT OF THE AGREEMENT BETWEEN IT AND TAIT IN RELATION TO THE SOFTWARE OR FIRMWARE WHICH SUPERSEDES ANY PROPOSAL OR PRIOR AGREEMENT, ORAL OR WRITTEN AND ANY OTHER COMMUNICATIONS BETWEEN THE LICENSEE AND TAIT RELATING TO THE SOFTWARE OR FIRMWARE.

Directive 1999/5/EC Declaration of Conformity

da **Dansk**

Undertegnede Tait Electronics Limited erklærer herved, at følgende udstyr TBBA4A, TBBB1A, TBBB1B, TBBC0A, TBBH5A & TBBH5B overholder de væsentlige krav og øvrige relevante krav i direktiv 1999/5/EF.
Se endvidere: <http://eudocs.taitworld.com/>

de **Deutsch**

Hiermit erklärt Tait Electronics Limited die Übereinstimmung des Gerätes TBBA4A, TBBB1A, TBBB1B, TBBC0A, TBBH5A & TBBH5B mit den grundlegenden Anforderungen und den anderen relevanten Festlegungen der Richtlinie 1999/5/EG.
Siehe auch: <http://eudocs.taitworld.com/>

el **Ελληνικός**

Με την παρουσία Tait Electronics Limited δηλώνει ότι TBBA4A, TBBB1A, TBBB1B, TBBC0A, TBBH5A & TBBH5B συμμορφώνεται προς τις ουσιαστικές απαιτήσεις και τις λοιπές σχετικές διατάξεις της οδηγίας 1999/5/EK.
βλέπε και: <http://eudocs.taitworld.com/>

en **English**

Tait Electronics Limited declares that this TBBA4A, TBBB1A, TBBB1B, TBBC0A, TBBH5A & TBBH5B complies with the essential requirements and other relevant provisions of Directive 1999/5/EC.
See also: <http://eudocs.taitworld.com/>

es **Español**

Por medio de la presente Tait Electronics Limited declara que el TBBA4A, el TBBB1A, el TBBB1B, el TBBC0A, el TBBH5A y el TBBH5B cumplen con los requisitos esenciales y cualesquiera otras disposiciones aplicables o exigibles de la Directiva 1999/5/CE.
Vea también: <http://eudocs.taitworld.com/>

fi **Suomi**

Tait Electronics Limited vakuuttaa täten että TBBA4A, TBBB1A, TBBB1B, TBBC0A, TBBH5A & TBBH5B tyyppinen laite on direktiivin 1999/5/EY oleellisten vaatimusten ja sitä koskevien direktiivin muiden ehtojen mukainen.
Katso: <http://eudocs.taitworld.com/>

fr **Français**

Par la présente, Tait Electronics Limited déclare que l'appareil TBBA4A, TBBB1A, TBBB1B, TBBC0A, TBBH5A & TBBH5B est conforme aux exigences essentielles et aux autres dispositions pertinentes de la directive 1999/5/CE.
Voir aussi: <http://eudocs.taitworld.com/>

it **Italiano**

Con la presente Tait Electronics Limited dichiara che questo TBBA4A, TBBB1A, TBBB1B, TBBC0A, TBBH5A & TBBH5B è conforme ai requisiti essenziali ed alle altre disposizioni pertinenti stabilite dalla direttiva 1999/5/CE.
Vedi anche: <http://eudocs.taitworld.com/>

nl **Nederlands**

Hierbij verklaart Tait Electronics Limited dat het toestel TBBA4A, TBBB1A, TBBB1B, TBBC0A, TBBH5A & TBBH5B in overeenstemming is met de essentiële eisen en de andere relevante bepalingen van richtlijn 1999/5/EG.
Zie ook: <http://eudocs.taitworld.com/>

pt **Português**

Tait Electronics Limited declara que este TBBA4A, TBBB1A, TBBB1B, TBBC0A, TBBH5A & TBBH5B está conforme com os requisitos essenciais e outras provisões da Directiva 1999/5/CE.
Veja também: <http://eudocs.taitworld.com/>

sv **Svensk**

Härmed intygar Tait Electronics Limited att denna TBBA4A, TBBB1A, TBBB1B, TBBC0A, TBBH5A & TBBH5B står i överensstämmelse med de väsentliga egenskapskrav och övriga relevanta bestämmelser som framgår av direktiv 1999/5/EG.
Se även: <http://eudocs.taitworld.com/>