

THE LOCKSMITH

TM

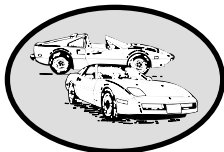

**WINTER
1995**

The Official Publication of the **NATIONAL LOCKSMITH AUTOMOBILE ASSOCIATION™**

Publisher's Page	page 3
Director's Page	page 4
Starting Line	page 5
GM'S MATS system at work	page 7
Life In The Fast Lane	page 10
Joe's Garage	page 17
Dealing with Dealers	page 22
How The Heck...?	page 23
Nuts & Bolts	page 25
Feature Articles:	
Top To Bottom Camry	page 1
Dale Does: High Tech Car Opening Tools	page 28
Opening The 1994 Honda Accord 2 Door	page 30
A Car By Any Other Name	page 39

FEATURE ARTICLE

Top To Bottom Camry

By Michael Hyde

The 1994 Toyota Camry is one Toyota's best selling cars, as most Camry's have been in the past. (See photograph 1.)

Because the lock linkage rod is out of normal view, when trying to reach this rod follow the inside release linkage

forward and then pull up to engage the lock/unlock linkage rod where it is not covered by the plastic shielding. (See photograph 2.) The use of a good bright car opening light is a

(Continued on page 32)



**1. The 1994
Toyota
Camry.**

**Marc Goldberg**

*Welcome to the
National Locksmith
Automobile Association!*

Welcome! This is the very first newsletter issued by a brand new Association, the NLAA. The NLAA was formed for YOU, and of course, this makes the *Automotive Edge* your newsletter.

Our job here is to bring you the newest, the latest, the very HOTTEST automotive locksmithing information available anywhere! And we'll work very hard to do that for you in every aspect of the NLAA.

Four times per year, you'll receive a copy of the *Automotive Edge*, just like this one. And six times per year, you'll receive a healthy set of NLAA Technical Bulletins, giving critical details on a range of new and challenging cars.

Notice that both this newsletter and the Technical Bulletins are three hole punched. We suggest that you place all your Membership Mailings in a three ring binder so you have them accessible when you really need them: When you get called out on a job! If you wish, you may send us a check for \$10 and a request for an official NLAA Binder. But you can easily use any three ring binder to organize your materials.

The NLAA does have a great many plans to be announced over time. For example, we are now starting work on a Certification Program, so that you will be able to test and become Certified in Automotive Locksmithing by the NLAA. Seminars will be announced before long, for which NLAA members will receive huge discounts.

The NLAA Code and Car Hotline is already set up and functioning. Members who call in can receive technical assistance rapidly. One new benefit of Membership has been the \$15 discount on the new AutoSmart manual. Many members report this book has saved them lots of time and trouble when working on cars.

At this time, we are also teaming up with manufacturers to give you more information than has ever been available. Thanks for joining the NLAA! It's gonna be a great year!

**National Locksmith
Automobile Association™**

Publisher
Marc Goldberg

Director
Tom Seroogy

Printed in U.S.A.
NLAA, a division of
National Publishing Co.
Publishers of
THE NATIONAL LOCKSMITH

1533 Burgundy Parkway
Streamwood, Illinois 60107
Phone 708-837-2044
Fax 708-837-1210
E-mail address: natllock@aol.com

Unsolicited manuscripts are
accepted, but must include
SASE.

© 1995 National Publishing Co.
All Rights Reserved

Winter 1995



Tom Seroogy

***Auto Network—
Learning Together.***

Hi. Welcome to the first issue of *The National Locksmith Automobile Association's* "The Automotive Edge." Unlike any other publication brought to locksmiths, The Automotive Edge will explore all facets of locksmith auto service - Feature articles cover specific autos from head to toe, including opening procedures, lock removal and service, key generation, key and lock specifications, replacement part and service kit numbers.

Each issue includes articles on High Security vehicles for the advanced auto tech down to standard GM, Ford and Chrysler service and lock repair for the beginner.

Time will be spent on important auto issues that affect your day to day operation. In this issue's "What The Heck...?," for example, we cover warnings and procedures on GM's equipped with the Delta-LOC I and Delta-LOC II systems. Don't get caught unprepared working on these cars.

In Nuts & Bolts we take a look at tools, both old and new, that

make our jobs simpler. Plus, in each issue Dale Libby reviews car opening kits and tools from the major manufacturers.

Now, most of this work is not done by me. There's no way I could possibly cover all this material by myself. Actually there are going to be three major players in the creation of each "The Automotive Edge."

First are our writers. Included are Jake Jakubowski; Dale Libby, long time safeman and auto locksmith; Tom Mazzone, locksmith and GM Master Technician; and Michael Hyde, automotive locksmith expert and writer of *The National Locksmith's* AutoSmart auto reference manual.

Second, there are the locksmith automotive tool manufacturers and distributors. They supply us with the new and improved that make our job easier. They provide us with coming changes in the auto industry, including new codes, new lock and key systems, new service procedures, etc.

Finally, there is you. That's right, you!

We're making an unusual stand here at the NLAA. Our philosophy isn't based on us knowing it all, it's based on all of us knowing.

A single person or organization

cannot cover the full gamut of the auto industry, it requires teamwork - teamwork from all the participating locksmiths. While we give you as complete a spectrum as possible, we know we're not infallible, we know exceptions exist, we know there are techniques and methods unknown to us and to the rest of the locksmith community. And with your help, we'll discover them and let it be known to the rest of our locksmith team.

In short, we are your Locksmith Central, the center of a vast network of automotive locksmiths.

So, let us know what's on your mind. Write to us with your exceptions, new techniques and methods, and questions. In today's competitive market networking is another tool for gaining that upper Automotive Edge.

And don't forget, *The National Locksmith* is now on-line. Those on our team with computers have direct contact with us through this new service. Plus, in the near future, by adding your E-mail address to our list, we can bring you the latest auto tech info even before it's published. Our Address is: America On line - NATL LOCK, or Internet - natllock@aol.com. Send me your E-mail address!

Reading GM Door Locks

By Tom Seroogy

One of the cold, hard realities of doing GM service work is that every now and then, a door lock will have to be removed in order to generate a door key. For many beginners this was a formidable task. Not the removal from the door, necessarily, but the disassembly and fitting of a key to the lock.

From the beginning, most of us were taught that in order to make the key, the tumblers from the lock would have to be removed and read. This, of course, means that the tumbler

cap and springs have to be removed. Unfortunately, this task is not that easy. Because the ends of the tumbler cap are securely staked into the plug, the cap's retaining tabs often tear off and remain in the plug, rendering it useless.

To avoid these troubles, we'll take a look at a simple technique for reading these locks without removing the tumbler cap and springs.

As in the standard procedure, remove the lock from the vehicle. Remove the face cap, dust cover, dust cover springs and lay them aside (except the face cap which is destroyed, always

have spares on hand).

After removing the plug from the shell, use your finger to depress the sidebar. Insert a pick into the keyway and rake the tumblers until the sidebar has been picked. This has been achieved when the sidebar drops flush with the plug, or shearline. (See photograph 1.)

With the plug picked, look into the tumbler chambers, next to the tumbler cap. The tumblers can be seen, and will be set at various depths. These depths are the depths of each cut and this is what we want to read. (See photograph 2.)

If reading this lock by sight, it is best to give yourself a point of index or registration while reading. In most cases, a



1. Remove and pick the door plug.

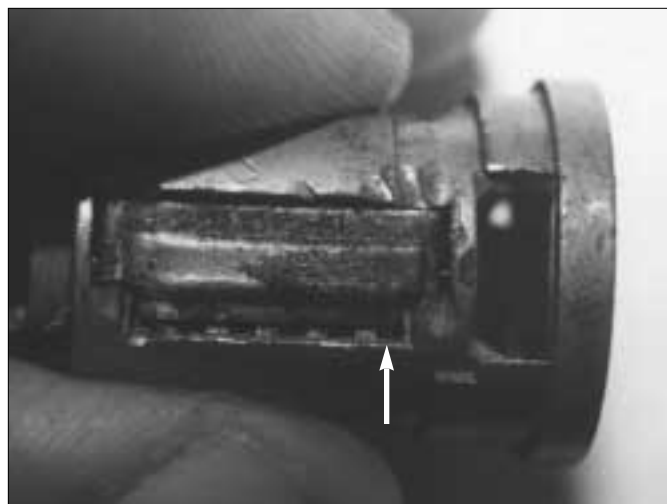

2. After picking, the tumbler depths can be seen looking down into chamber.

tumbler that is just up under the tumbler cap, near the surface of the plug is a #1 depth. From there it gets progressively deeper.

While sight reading these locks takes practice, for beginners, it is often best to use a decoding tool. These tools are inserted into the tumbler chamber and rest on top of the tumbler, gauging its depth. Obtain the depths for each tumbler and cut the key

respectively. (See photograph 3.)

When reading and cutting the key, however, it is important to remember the GM rules of progression:

1. All the cuts of the bitting when added together equal an even number.
2. The Maximum Adjacent Cut Specification is two, meaning adjacent cuts cannot be more than two increments or depths apart.

3. Three consecutive cuts cannot have the same depth.

4. The same depth cannot appear more than four times in any bitting.

Following these rules and using the readers will make swift work in making any door key. It should also be stated that this same procedure can be used on ignition locks where the code is not present on the shell.



3. Decoders like HPC's GMTD 5 and A-1's GM Door Lock Decoder can help the beginner learn to read GM door locks.



Is MATS Enough?

By Tom Mazzone

Engineering at General Motors is once again tirelessly working on ways to thwart vehicle theft. In tandem with its very successful PASS system, GM introduced the MATS system in 1992 in its full sized, rear wheel drive cars. These vehicles were the Buick Roadmaster, the Chevrolet Caprice, and the full sized Oldsmobile Custom Cruiser station wagon. Their body designation code is "B" body.

In 1993, this system was brought into use on the full sized vans and full sized "C" and "K" Suburbans. Finally, in 1994, the system was incorporated into the smaller Blazer and Jimmy series. Their body designation code is "S" and "T" series.

MATS is an acronym for Mechanical Anti-Theft System. It is a very simple type of system that is almost unrecognizable from the outward appearance of the steering column.

The first issue to address is how this system can help to stop a thief from stealing the vehicle. The system has a steel plate immediately below the steering wheel covering the steering shaft lock plate and bolt. It is held in place with two T15 Torx screws that thread into

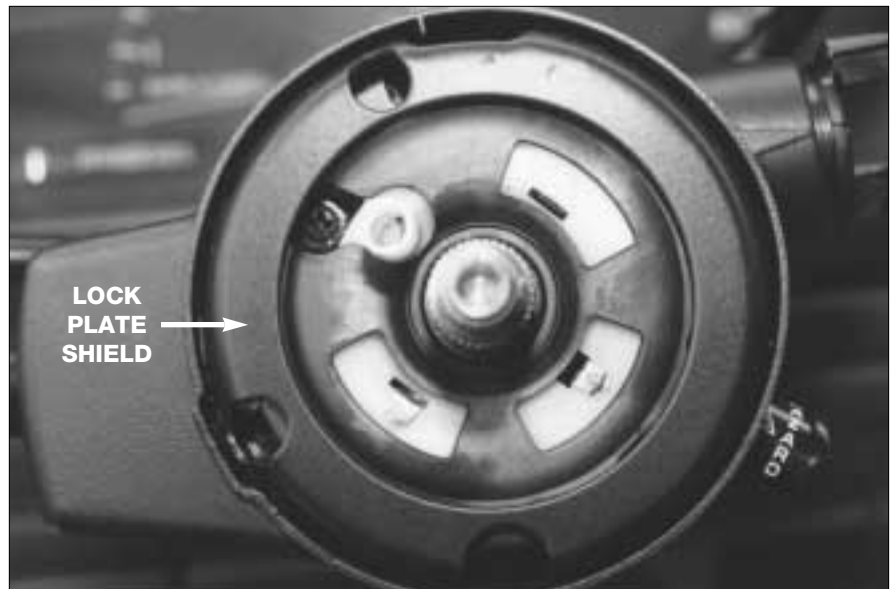

1. The upper lock plate shield is visible after removing the steering wheel.



2. An attempt to steel this vehicle resulted in the lower shifter bowl and rack being broken. The steel armored sleeve, however, protected the sector gear and steering wheel lock bolt from attack.

the lock cylinder bowl. (See photograph 1.)

The lock cylinder bowl itself is protected with a steel liner that protects the sector gear and lock plate bolt from attack. (See photograph 2.)

The plastic sector gear is not serviceable as in previous years. The sector gear is staked to the ignition lock drive shaft which connects the lock cylinder and the sector. Prior to this change, the plastic sector gear was serviced as part of a GM rack service kit. The upper lock housing assembly and the sector gear are now serviced as one unit when equipped with MATS. (See photograph 3.)

In order to steal the non-MATS vehicle, a would be thief breaks the lower side of the shift bowl to expose the rod that is connected to the ignition switch located at the base of the column. The rack assembly is then broken away from the ignition switch rod. (See photograph 4.) Lifting up on the rod cranks and starts the engine. (See photograph 5.)

At this point, however, the

steering wheel lock bolt is still locking the steering wheel. Using the screw driver the thief breaks away enough of the shift bowl to expose the sector gear and bolt spring. A long nose pliers or a stiff piece of wire with a hook on it is then used to remove the spring, allowing the steering wheel lock plate to be freed from the steering wheel lock plate bolt. The wheel now turns freely and the vehicle can be driven away.

With the MATS liner, however, while access can still be made to the ignition rod, it does prevent easy access to the sector gear by blocking the gear from attack. Also the sector/bolt spring is mounted behind the gear instead of being exposed from the left side. This prevents attack to the steering wheel lock bolt and keeps the steering wheel lock plate (and steering wheel) from being turned. (See photograph 6.)

There is still the possibility that if enough force is used, the splines in the lock plate can be stripped

away or the plate can be mushroomed upward at the lock plate holes to allow the wheel to turn. Unfortunately, enough brute force can accomplish this as some MATS equipped vehicles have been stolen.

MATS will greatly slow down the average car thief and that may be all the edge the police need. There is however, no need for the locksmith to be apprehensive about lock service on one of these vehicles.

An easy way to tell if a vehicle is equipped with MATS is to look between the steering wheel and the upper column housing on the left side. If you see a metal plate with a rounded edge and two holes in it instead of the plastic lock plate shield, then it is MATS equipped. With the exception of the removal of the guard plate, MATS service is business as usual. Unless



3. Despite the damage to the lower bowl, the sector gear and steering wheel lock bolt remain unscathed.

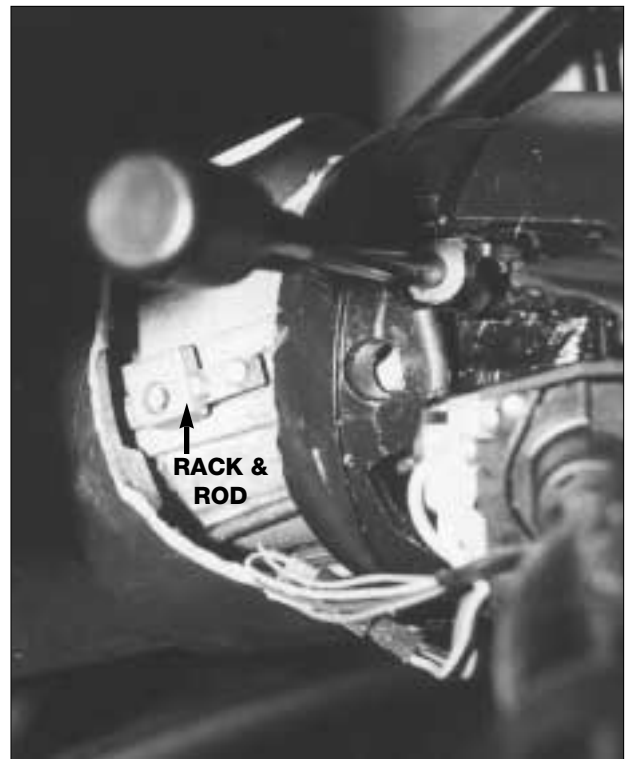

4. Breaking through the lower shifter bowl exposes the rack and ignition switch rod.

your business takes you into complete column rebuilding, you will never have to service the shift bowl liner.

To remove the steering wheel lock plate guard, take notice of the position of the steering shaft block groove. The block groove is the area of the shaft that has more metal in between it's adjacent splines than the others. This block groove must be moved to the seven o'clock position to provide access to two larger holes in the lock plate. It is through these two larger holes that the two legs that secure the guard to the

upper lock housing pass through for removal. Two number T15 Torx screws attach this plate.

In order to turn the steering shaft, a special tool from Kent Moore is used to depress the lock bolt, relieving pressure on the shaft. Kent Moore's part number for this tool is BT91108. With the aid of another special Kent Moore tool, the steering shaft is turned using either a ratchet or the straight rod that comes with the tool. The part number for this tool is BT9213.

Insert the depressing tool through hole at the eleven

o'clock position and push down until you feel the bolt clear the plate. Put the BT9213 socket over the steering shaft and turn the shaft in either direction to place the block groove at the seven o'clock position. Remove the two screws in the guard plate that are now exposed and lift the guard straight out.

At this point, the locksmith is now in familiar territory. Standard column procedure from this point is all that remains. Keep your eyes open for further changes from the different manufacturers!



5. In a typical theft, the lower bowl is broken and the rod and rack lifted to start the vehicle.

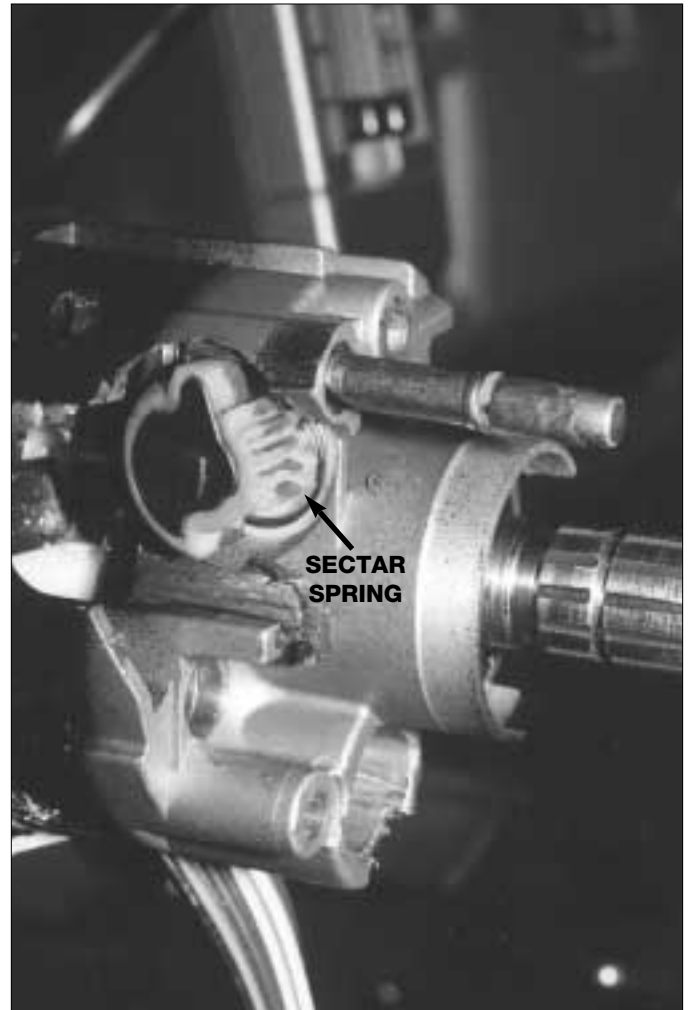

6. The sector gear and its components are now part of a single assembly and cannot be serviced or replaced alone. The spring controlling the steering wheel lock bolt is also hidden from reach, making theft harder.

Lexus LS400 **Service Procedures, Part I** **By Michael Hyde**

The Lexus LS400 is one of Lexus' best selling cars. The LS400 is the flagship of the Lexus line, it is also the top of the line automobile from Lexus. Photograph one shows a side angle and tail view of the car. What is missing? The 1990 through 1994 LS400 is the only Lexus that does not have the model name on the exterior. The Lexus also uses a unique High Security key, utilizing a 4-Track Internal High Security keyway.

(See photograph 2.)

Because of the complexity of working on this vehicle, we will cover it a step at a time, starting with opening techniques and then moving into lock removal.

Opening Techniques

This car can be a tricky one to open. It is not difficult, just tricky. Let me explain, once you have unlocked the car, it re-locks itself. The Lexus line uses a sophisticated locking system

that knows the key is not opening it, so the car's alarm system is activated and the door lock motors re-lock the car within approximately one second of time to spare. An inside the car opening tool, sometimes referred to as an Under-The-Window tool, can be used to open this vehicle. A closer look at the tool in the working position is shown in photograph three. I usually enlist the customer's help when



1. The front and rear view of the Lexus LS400.





2. The Lexus 4-Track Internal High Security key.

I open these cars, by having the customer pull up on the handle in fast repetitive motions, as I unlock the car.

Ignition Lock

The ignition cylinder is easier to remove than it appears. There is a padded dash cover that sits over the cylinder. The cover simply snaps right off with a gentle pulling pressure and then remove the screw that holds the plastic bezel in place. (See photograph 4.) Stop now and

disconnect the battery, before proceeding. Insert a working key and turn the key to the ACC (accessory) position. Reach in with a L-shaped probe on top of the ignition housing and depress the retainer and pull out the ignition cylinder. (See photograph 5.)

You can always tell a Lexus High-Security ignition cylinder because when you look directly at it you can see the two key guides sticking out in the keyway giving it a look of the



3. Opening the LS400 using an Under-The-Window tool.



4. Remove the dash cover and the plastic bezel from around the lock.



5. The cylinder coming out of the housing.



6. Looking into the keyway reveals the High Security "H" shaped keyway.

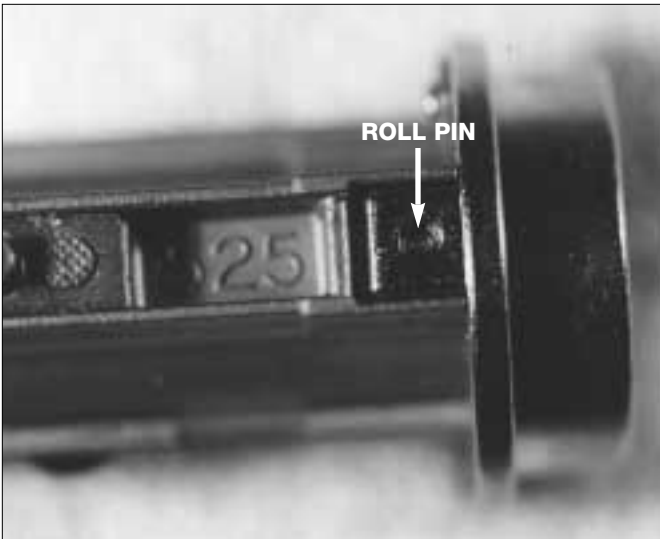

7. The face cap is held to the lock body by both a roll pin and two staked posts.

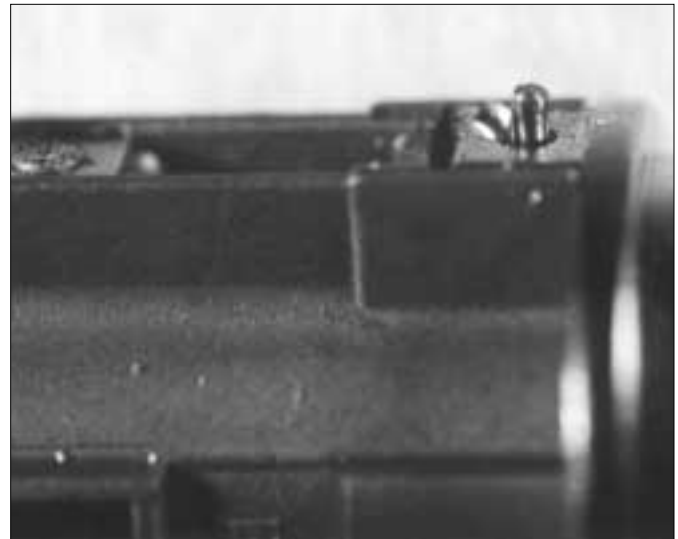

8. Drill a small hole next to the pin and pry it out with a pin punch or scratch awl. Then use a punch and gently tap the staked posts through the body to remove the face cap.



letter "H." (See photograph 6.)

To disassemble the cylinder you must first remove the ignition face cap. It is held on by a roll pin located on the top and two staked posts found at its back. (See photograph 7.) I drill a small hole directly next to the pin in order to use a pin punch to pry out the pin.

To remove the face cap without damaging the two staked posts, place the cylinder in a vise. Do not over tighten the vise and crush the lock. Use a pin punch and a hammer to strike the posts in consistent light blows to each post in succession to allow the posts to travel back through the cylinder housing and avoid breaking the

posts. (See photograph 8.) Next you will need to remove the plug retaining ring on the back of the cylinder. Photograph nine is a look at the face cap once it has been removed from the cylinder housing.

Insert the key and remove the plug. (See photographs 10.) Note the tumbler positioning as seen in photograph 11. The first three positions are for split tumblers

and the next four positions are solid tumblers. There is no eighth position tumbler in the plug.



9. The face cap removed.

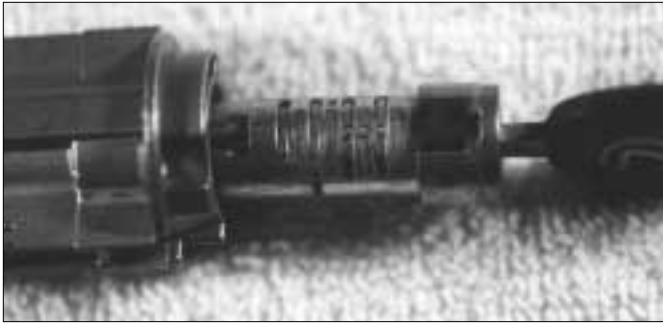

10. Use the key to remove the plug.



11. The ignition is made up of a combination of split and whole wafers. There is no eighth position tumbler in this lock.



12. The trunk release lock.

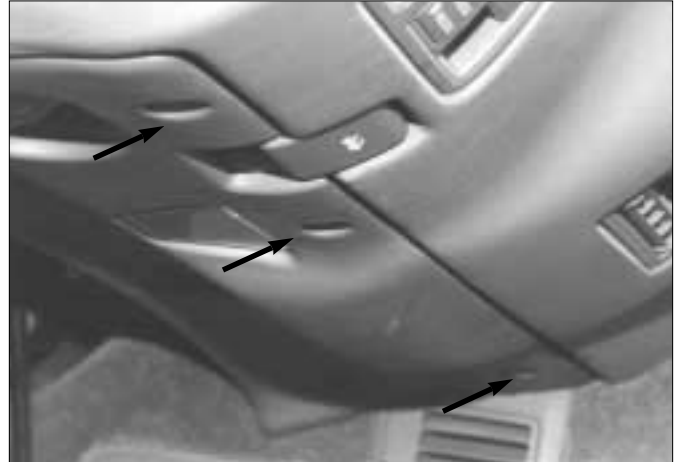

13. Remove three screws and drop the knee bolster or lower panel to get to the trunk release lock.



14. The six 10mm bolts needed to lower this panel are easily located and removed.

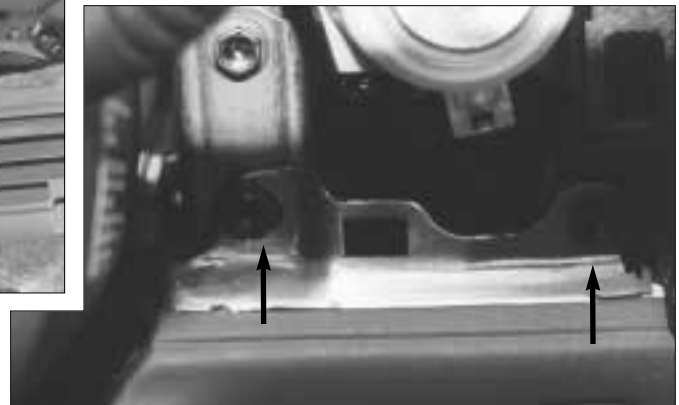



15. The panel lowered.

Valet Lock-Out Switch

At the bottom driver's side of the dash board is a trunk release lock. (See *photograph 12.*) In the locked position you are prevented from opening the trunk using the electrical release. This cylinder also contains all the tumblers that appear in the trunk lock. To get to the lock, the lower cover has to be removed and is held in place by three screws. (See *photograph 13.*) As the panel is lowered a large spring clip can be seen. This clip holds the panel to the steering column, pulling down on the panel releases the clip.

The next panel to remove to gain access to the lock is the lower driver's side panel, there are six 10mm bolts to remove, and are quite easy to get to. The first two 10mm bolts are found at each end of the panel, easily seen and easily removed. Two more 10mm bolts are located directly under the Parking Brake Release, you can see them and remove them without having to move anything out of the way. The last two bolts to

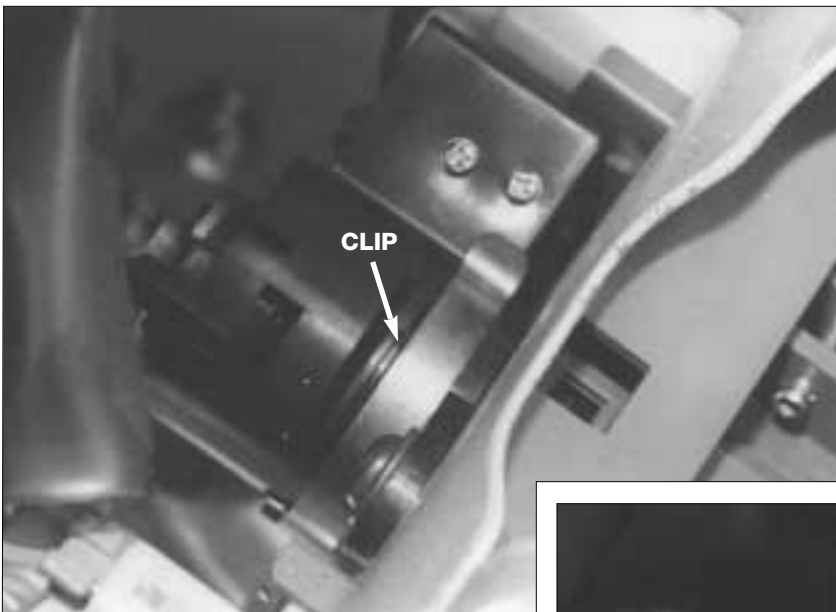

16. Remove the clip from around the lock and depress the lock retainer to unlock the trunk release.

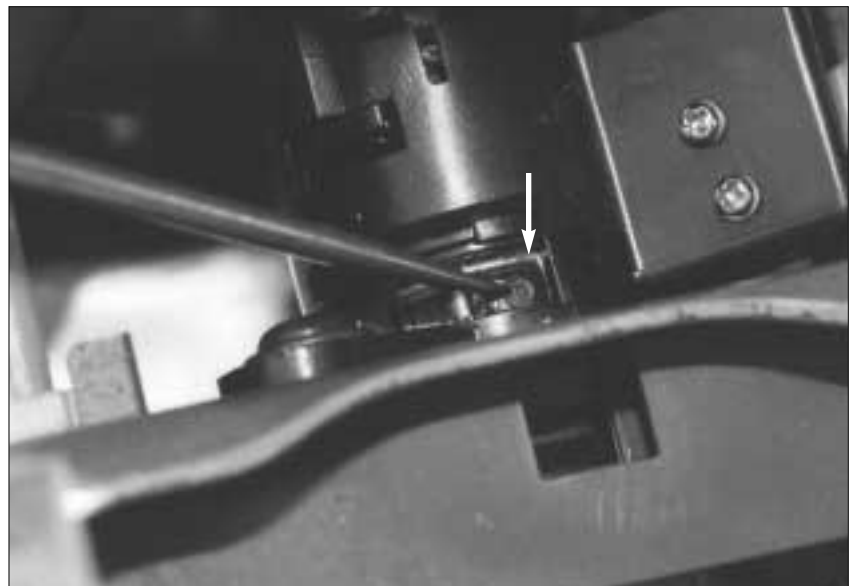



17. Remove the two screws to remove the lock from the release.



18. Remove the micro-switch attached to the lock.

remove are directly under the ignition cylinder housing. (See photograph 14.)

There is a padded dash cover that hides these last two bolts. The cover just snaps off with a gentle pulling action (as discussed earlier in the Ignition servicing section). There are a couple of snaps that hold the panel in place and once you remove the six screws, gently pull outward on the panel to dislodge it. (See photograph 15.)

On the backside of the valet lock-out key cylinder there is a

spring wire clip. Remove the clip and push in on the lock retainer and the lock will return to the unlocked position. (See photograph 16). Now if that isn't a nice trick, I don't know what is.)

There are two screws that hold the lock housing in place. Remove the screws and then pull outward on the cylinder housing to snap it apart from the front trim bezel. (See photograph 17.)

To avoid damaging it, the electrical micro-switch on the

back of the lock must be removed. It is held in place by two small screws. (See photograph 18.) Remove the E-clip that holds the tailpiece to the lock. (See photograph 19.) Before you remove the tailpiece, take note of what I call the turning spring and its exact location. Remove the E-clip, remove the tailpiece, remove the turning spring.

The next piece to remove is the plastic stopping disc. The disc is held in place on two sides of the housing, if you



19. Remove the E-clip to remove the tailpiece.

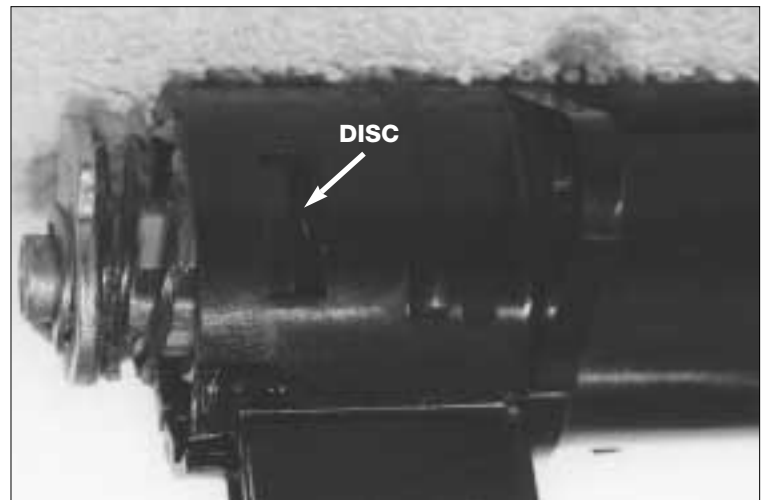

20. Gently remove the plastic disc from the back of the lock.

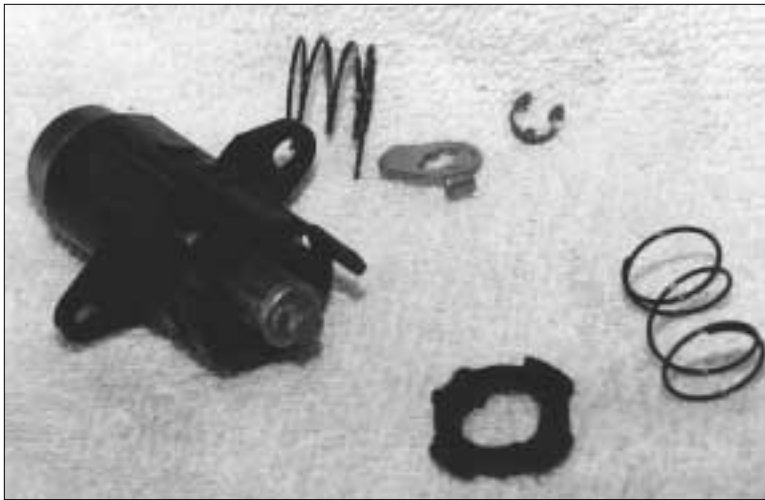

21. We now have access to the lock cylinder.

gently, and I mean gently, use a small screwdriver you can remove the disc by wedging it out of the way. *Photograph 20* shows one side of where the disc is held in place. Once the disc is removed be careful not to lose track of the push-spring held in place by the disc.

Photograph 21 is a view of the lock disassembled to the point where the lock cylinder can be accessed. The lock cylinder can be removed from the housing by sliding it out the rear of the assembly. It may be necessary to push in on the lock retainer to ease this procedure. (See *photographs 22.*)

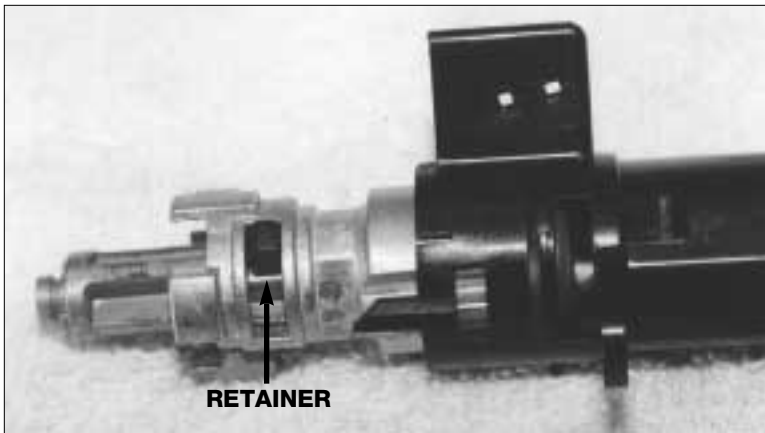

22. Remove the lock cylinder. Pressing on the retainer may be necessary to facilitate the removal.

Remove the re-usable face cap and then slide the plug out the front of the cylinder housing. (See *photograph 23.*) It may be necessary to push in on the retainer to ease the plug out, watch out for the retainer as the plug is exposed the retainer and the spring behind it may go flying. There are eight tumbler positions in this lock, first four are solid, next three are split, and the last one is solid. (See *photograph 24.*)

Next issue we'll cover the door, trunk and glove box lock removal. 17

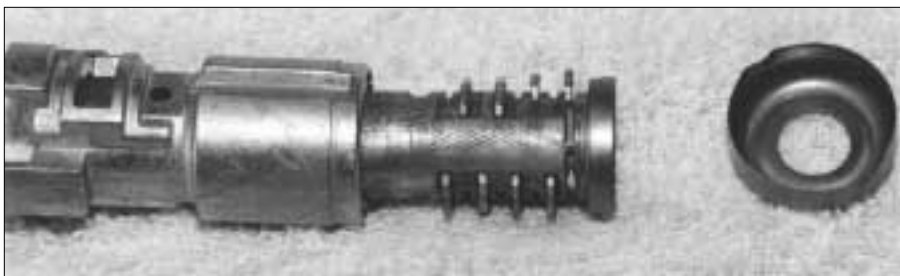

23. The disassembled lock.



24. The plug and all of its tumblers.

Do you have
an E-mail address?
Send it to us!
AOL: NATL LOCK
Internet: natllock@aol.com

GM Large Body Truck Door Lock Removal

By Jake Jakubowski

During the 1950's and into the mid-60's the door handle and lock cylinder on Chevrolet and GMC pick-up trucks, and larger models as well, was a fairly straightforward affair. (See *photograph*

1.) Take off the inner door panel, remove a couple of screws and the handle came off the door for servicing.

About 1966, General Motors took the lock cylinder out of the handle mechanism and put it

on the door panel, below the handle. (See *photograph 2.*) That simplified service. Just remove the inner door panel, pull the lock retaining clip and the lock cylinder could easily be removed.



1. Before mid-1960, the Chevrolet/GMC truck door handle and lock were one unit and easily serviced.



2. Around 1966 the lock was separated from the handle.

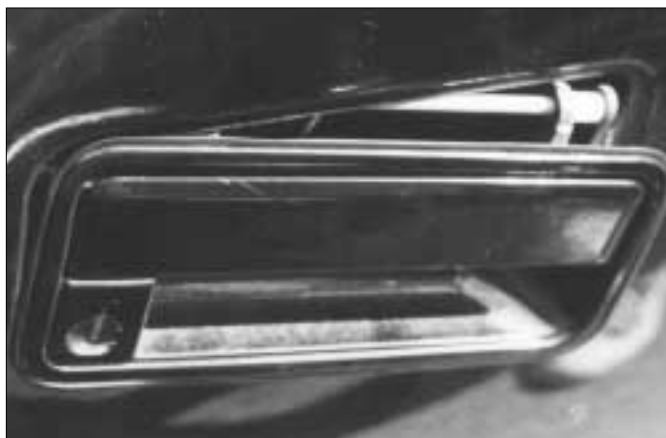

3. The new style GM truck lock and handle.



4. The inner steel panel, while needing to be removed, has all the internal door and window components attached to it.

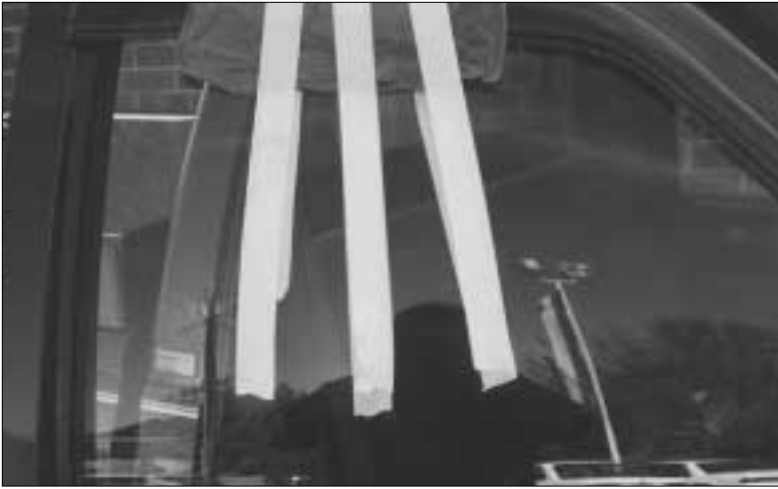

5. Tape the window in place before starting.



6. Loosen but do not remove this bolt on the inner door panel.



7. Loosen the latch using a T30 Torx screw driver.



8. Pulling the handle out gains access to the linkage on the door handle assembly.

However, at the time GM was designing the 1988, full-sized, Chevrolet Silverado door handle/lock cylinder mechanism the idea of service simplicity got lost. (See photograph 3.) The lock now became an integral part of the handle and the cylinder retainer release behind the window track!

Also included in the changes, GM attached the window regulator, the window drive motor assembly and other door components to the inner, steel door panel. (See photograph 4.)

The result was, to say the least, interesting when an unsuspecting locksmith attempted to service these new style locks on Silverados! Taking off the padded door panel, the locksmith would encounter the inner panel. No problem! Just take out all those

screws and

As the last screw was removed the inner panel, window, window regulator, and all - made a nosedive for the ground. While the hapless locksmith made a desperate grab to forestall disaster, the edges of the inner door panel came alive and began chewing finger flesh!

To save yourself the trouble, as well as your fingers, first tape the window in place then remove the padded interior panel. (See photograph 5.) After

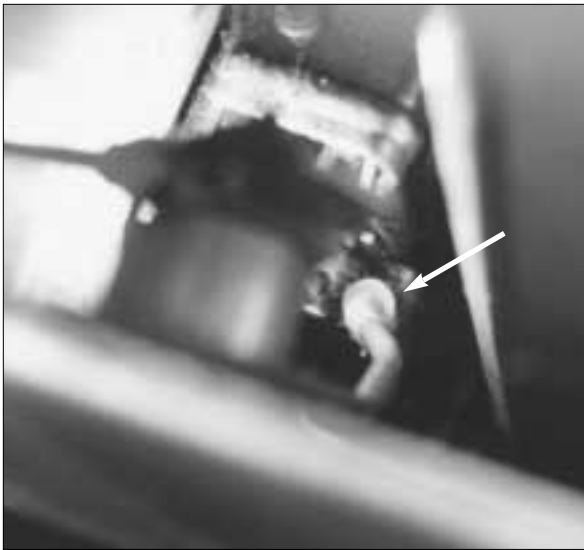

9. This rod often becomes disconnected from the latch during lock removal and is very difficult to replace.



10. Remove the window crank and inner door panel.



11. If electric windows are used, remove and disconnect the window control module.



12 Remove the handle retaining screws with a 10mm socket.

removing all the screws on the inner steel panel - except the one in *photograph six*. To avoid trouble, simply loosen this bolt for now.

Then loosen the Torx screws that holds the latch mechanism in place. (See *photograph 7*.) After removing the handle bolts, this allows the handle assembly to pull far enough away from the door to remove the retaining

clips from the linkage rods, allowing you to take the handle assembly to your truck for servicing. (See *photograph 8*.) Whew! To reassemble, you simply (Simply?) reversed the procedure. Repeating the strain and aggravation - especially if you have hands the size of mine.

The problem is, that after loosening the latch mechanism

to gain enough "play" to expose the clips on the linkage for removal, the door handle linkage often pulls out of its seat in the latch assembly and requires a lot of maneuvering and finagling to coax it back into place. (See *photograph 9*.)

Fortunately, a way was found to ease the strain and aggravation associated with servicing these locks.

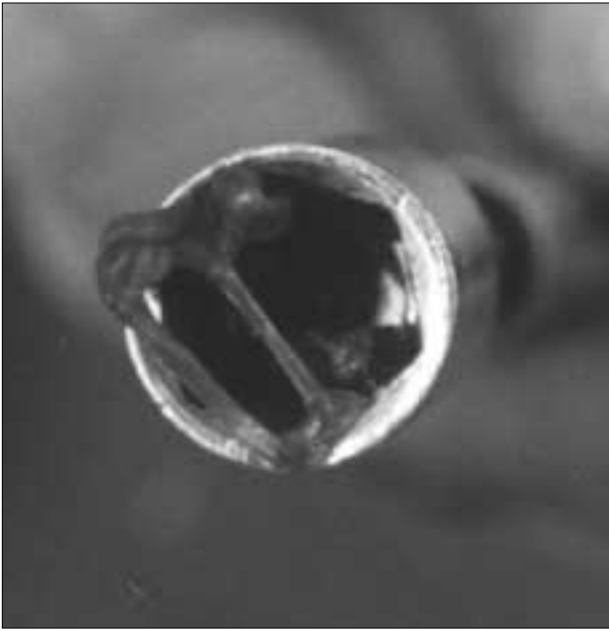

13. To prevent the screw from dropping into the door, place some of the dust cover adhesive inside the socket.

To remove the lock cylinder from these vehicles, remove the window crank and take the screws out of the arm rest and remove the padded door panel. (See photograph 10.) If electric windows are used, disconnect and remove the electric window

control module as shown in photograph 11.

Remove the handle retaining screws. One screw is found on the outside door edge. The other is found inside the door and you'll need a 10mm socket and a 6" extension to remove it.



14. Pull the handle out just enough to reach inside with a probe.

(See photograph 12.) If you don't want to drop the screw in the door cavity, put a little of the adhesive that holds the dust shield in place on your socket. (See photograph 13.)

Now you can ease the handle module far enough out of the



15. Use the probe to depress the lock's retainer and remove it from the handle. The position of the retainer's access hole in the handle and the lock's retainer seen above.

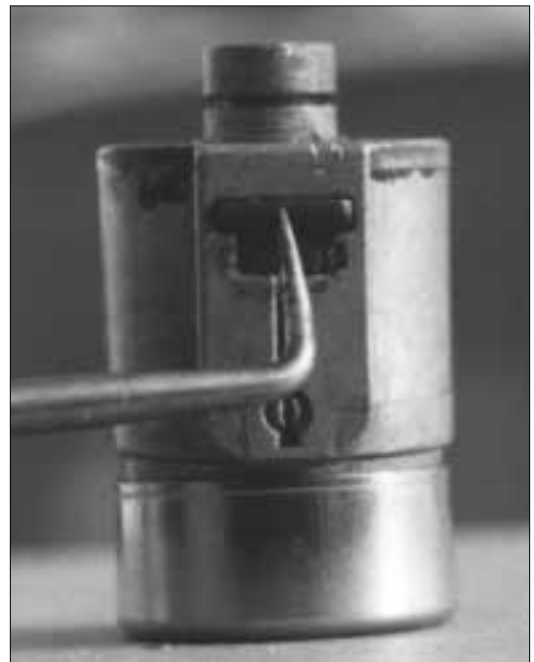



16. Push the lock out of the handle.

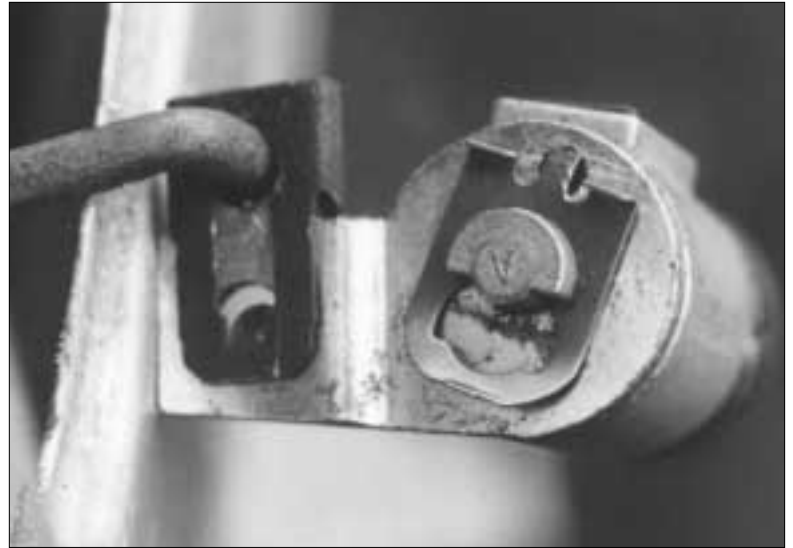

17. Pull the lock out of the door and disconnect the linkage.



18. After the handle has been placed back into the door, use the special key and pull the lock into its seated position.

door to get a small hooked probe into position to depress the cylinder retainer that holds the lock cylinder in place. (See photographs 14 and 15.)

While depressing the retainer, push on the face of the cylinder and let it fall back into the door cavity. (See photograph 16.) This will give you enough

maneuvering room to gently work the handle module free of the door. Once free, let it hang over the edge of the opening. You might want to wrap a rag or piece of paper toweling to the handle assemble to prevent it from scratching the door surface.

Next, reach in the door cavity and pull the lock cylinder forward far enough to allow you to remove the retaining clip that secures the cylinder to the linkage. (See photograph 17.) Remove the cylinder and

service as necessary.

Regardless of the type of service performed on the lock cylinder, the next step is to make a duplicate key and cut the head of the key. This will give you an operating key with a long narrow shoulder. Lay this key aside for the time being.

Now re-attach the lock cylinder to the linkage. Next, insert the special duplicate you made into the cylinder and turn it about 90° so that the key cannot be pulled out of the lock. Then, bring the handle module into position and insert the key and cylinder into its sleeve. Do not try to seat the cylinder at this time!

Gently work the handle assembly into the proper position. It's a tight fit but with a little effort and patience it will snap into place. When you've gotten the handle replaced, use a pair of needle nose pliers to pull on your special duplicate key until you hear (and see) the cylinder seat. (See photograph 18.)

Replace the two handle retaining screws - careful with the one to the front of the handle - check the operation of the lock and re-assemble the rest of the door as normal.

There's No Rainbow Over This Pot Of Gold By Tom Seroogy

Okay, why do auto work? Is it for the riches? The fame? A hobby? Maybe it's the cut up knuckles and hands?

Or, maybe, the late night openings in sub-zero weather for unappreciative customers without money is just one of life's little pleasures.

Or, for those of us in warmer climates, maybe it's that mid-afternoon drive in the sauna-on-wheels that's so enjoyable; heading out to make keys in a stranded and enclosed vehicle that's been basking in the sun's midday rays, frying on the black asphalt griddle below; and when we're done we get to collect payment from a customer verging on heat stroke.

For some reason, it seems that no other field in locksmithing has so many individuals so hell-bent on performing masochistic tasks as the automotive locksmith. Even a safeman will whine after experiencing a grueling day of automotive service. (I hope Dave McOmie sees this!)

So, why do we do it? Why do we go through all the trouble?

For several reasons, I think.

The most mundane of which is - to make a living. Other, more ethereal reasons include a sense of accomplishment, a sense of professionalism, an awareness that nobody else can do what you do or do it as well. However, and a I may be wrong, I believe that in all serious automotive locksmiths, there is a sense, a belief, that there's a gold mine out there, and given enough time, it will be found.

Well, guess what, locksmith? It's out there and this column is the map to your treasure. That's not to say it's easy. And, it's not for everyone. Automotive locksmiths are probably the most unappreciated, underpaid and overworked trade people there are. But, if you're willing to pay the price, the payoff can be great!

Now let me tell where that treasure can be found — Dealerships! That's right dealerships. However, remember, with every benefit there's a stipulation, a catch, the small print we often overlook. So, before I expand on the potential, let me explain the down side and why this type of work is not for every locksmith.

With dealer work praise and acknowledgment of your skill is rarely recognized. When it is, concessions often follow (i.e. lower pricing, volume discounts, favors, etc.).

Expect to do large amounts of work on credit. While 30 days is typical, 60, 90 and even 120 days are sometimes realized due to those mysteriously missing invoices, work orders or gremlins.

Be prepared for a paper chase. Dealerships usually require your invoice, a work ticket and a P.O. (short for Purchase Order) before they can submit your invoice for payment. If any one of these items is missing - you got it - you don't get paid!

The work order is filled out by the person who summoned you (usually the New or Used Car Manager). After he finds time to fill out the ticket, the P.O. must be filled out. In some dealerships the manager does both. In others it means the locksmith will be found waiting at the parts counter.

Another drawback is time. Aside from the paper chase, most dealerships aren't overly

(See Rainbow on page 24)

HOW THE HECK...?

Questions & Answers From Our Readers

QUESTION:

What went wrong? I was called to open a 1993 Honda Civic 4 door. My opening manual directed me to an Under-The-Window opening tool. When I used it I couldn't get it to go up under the window. I switched directions and got it caught. I ended up getting into the car using another tool, but still couldn't get my Under-The-Window tool dislodged.

*C.W. Coley
Texas*

ANSWER:

The Under-The-Window tool is probably one of the most versatile and useful car opening tools I own. Unfortunately, there are times I take its application for granted and get it caught in the door. While this normally means I get it caught after having gotten the one end into the car's passenger area, there are times that it gets caught down inside the door, typically wrapped around the window track and armature. At this point, door panel removal is necessary to remove the tool.

When using this tool, it's best to use a good light to maneuver around the obstacles in the door.

As far as opening the Civic, it's very simple. All

2- door Honda models from the mid-1980's to 1993 use horizontal lock linkage. All 4- door Honda models for the same period use vertical lock linkage. In all cases the linkage is unprotected and readily accessible. In some of these vehicles the lock has a lazy pawl.

In your particular case, a 4-door Civic, use a wedge and light to locate the lock button rod near the latch side of the door. Use a slide lock tool to grasp the rod and lift to open.

QUESTION:

I had to make keys for a 1994 GM Cadillac with airbag and radio/cruise control horn pad for one of my dealers. Normally, I'd just get the codes from Roadside Assistance, but the codes they gave me didn't work.

While the entire procedure went down without a hitch, the radio locked up somehow and I couldn't get it to operate. Did I do something wrong?

*Russ McGelvick
Ohio*

ANSWER:

No. But let me explain a little about GM radio/horn pad systems.

GM currently has two Radio/Cruise Control horn pad systems: Delco-LOC I and Delco-LOC II, both designed to thwart radio theft.

The Delco-LOC I system, as far as I am able to derive, was introduced in the 1986 Pontiac 6000 LE, with the radio controls built into the horn pad. On this system, the horn pad and radio are integrally tied to one another through the use of a programmed module or chip. In order for the radio to operate, the module located in the horn pad must match the module in the radio. If the modules do not match, or if the horn pad or power are removed, the radio goes into a locked, LOC, mode and cannot be operated.

Because column service recommends battery disconnection, upon powering up the radio after service is complete, the radio will automatically go into the LOC mode. If the correct horn pad is reinstalled, the radio can be unlocked by depressing the MUTE button.

If the horn pad or radio is a replacement, a matching module must be placed in the respective component. This procedure must be done by a dealer.

The Delco-LOC II system made its debut in GM's

larger 1989 Oldsmobile and Cadillac vehicles. This is probably the system with which you are working. While this system will be covered in greater detail in our next issue, let me describe what probably happened and the solution.

Unlike the Delco-LOC I system, the Delco-LOC II system uses a six digit code to LOC and unlock the radio. When activated or in the SECURE mode, any voltage interruption to the radio causes it to go into the LOC mode, making the radio inoperable.

Considering you serviced an airbag column, I assume GM procedures were followed and the battery was disconnected. Because the radio went into the LOC mode, the previous owner must have had the radio in the SECURE mode.

To unlock the radio, the user code must be entered. Because there are three different versions for this procedure, they cannot be covered here.

Unlocking a radio without the use of a user code is pretty much restricted to a GM dealer. In short this procedure involves retrieving a radio ID number and using a Touchtone phone to retrieve a factory backup code. Unfortunately, the only way to access this

information is by entering a dealer number.

Again, we will more thoroughly cover this system and its operating procedures in our next newsletter.

QUESTION:

A customer drove in an older model Datsun using an X7 keyway. While the key operated the ignition okay, about 25 percent of the time the car wouldn't turn over. He claims a mechanic checked out all the systems and couldn't find anything wrong, but neither can I. Can you?

Steve Misowitz
California

ANSWER:

While I never give a "guarantee" diagnosis over the phone (or by newsletter) there are ignition lock problems that are easily misdiagnosed as relating to some other system on the car (i.e. battery, fuse, etc.).

In your particular case, Steve, it very well could be the electrical switch attached to the back of the ignition lock. In short, when the key is turned, a tailpiece or shaft turns a rotary switch at the back of the lock. In many instances, this switch is the failure. In some instances the center

hub or rotor that the lock shaft turns becomes cracked or splits in half. When the key turns, the broken rotor does not turn far enough to go to the IGNITION START mode. In other cases, the switch is just worn out.

To check for the problem, remove the switch from the back of the lock. Inspect the rotor for cracks or splitting. If this checks out okay, place the switch back into the ignition lock, but do not screw it down. Instead, while holding the key in the START position, slightly rotate the switch in both directions while in the

lock. See if there is intermittent contact. While this procedure is not a sure fire method for telling you whether a switch is *Good* it will definitely tell you if it is *Bad*.

If there is a split or cracked rotor, if there is intermittent contact, or if this seems like the most likely cause of the starting problem, the switch needs to be replaced. Switch replacements for many foreign autos are available from an Auto Security Products distributor. If not available there, contact a dealer. I`¶

(Rainbow, from page 22)

concerned with your schedule. Expect to spend time trying to find the manager who called you for service. Expect to spend time trying to find the car they want you to service. Expect to spend time chatting with inquisitive salespersons, car porters, service writers and mechanics. Expect to spend time trying to find the manager so you can hand over the keys and do the paper chase. In other words, expect to spend time, unproductive time.

Expect that the car you have to do *right now* has been sitting in the lot without keys for more than a week.

Also, expect lower fees. No animal on the face of the earth is as "deal" conscious as the auto dealer. Life, to them, is dealing. So, expect to be asked for "a deal," expect to do "a favor." Expect to hear, "as long as you're here, can you...?"

Expect to give the dealer the same price, at all times of the day and night, and under any circumstance. Expect being asked not to charge because they had you make keys for the wrong car.

Finally, expect little loyalty from the dealer. Dealers are known to change locksmiths for a dollar-a-car lower price, or for not being able to service them "NOW." Dealer work is tough, its demands often unrealistic!

Now, if you're still reading and want the "Rest of the Story," here it is.

According to a recent issue of the American Business List out of Omaha, Nebraska, there are approximately 14,141 locksmiths (shops) in the country. But there are:

- 24,943 New Car Dealers
- 73,170 Used Car Dealers
- 64,618 Body Shop & Repair Stores

- 22,666 Auto Rental/Leasing Stores
- 182,292 Repair/Service Stations
- 83,406 Service Stations

Add that up and what do we have? 451,095 business that can be shared by 14,141 locksmiths! (There are less locksmiths than that if you exclude those that do not do auto work.) That's right, almost one-half million opportunities where we can offer our services as Professional Automotive Locksmiths.

And to top this list, don't forget the 558 Auto Auctions and 1275 Repossessors around the country, Their business is a windfall for any locksmith who lands the account.

Next issue we'll discuss the organizational structure of a dealership. Believe it or not, their very mode of operation should make solicitation for business a dream come true. I`¶

Making Life Easy

By Tom Seroogy

A tedious and sometimes difficult task in GM steering column service is the removal of the steering wheel lock plate retaining ring. Using normal tools and procedures the lock plate is compressed using a steering wheel lock plate compressor and then the locksmith is left to the mercy of a couple of screw drivers to work the retaining ring from its seat and up the knurled, splined, broached, and threaded steering shaft.

One tool making this task more tolerable is HPC's SWLPC-1 Steering Wheel Lock Plate Compressor. (See *photograph 1.*) The unique design of this tool allows it to not only compress the steering lock plate and but includes a landing onto which the snap ring can slide, eliminating the torturous removal of the ring over the entire steering shaft. Because the ring remains on the tool until column reassembly, replacing the ring is simply a matter of sliding it down off the tool and into its seat.

The SWLPC-1 comes with both a standard thread and metric thread center post to accommodate the two steering shaft threading patterns used by GM. It also includes two set screws, one standard and one



1. HPC's SWLPC-1 Steering Wheel Lock Plate Compressor allows for easy removal and replacement of the steering lock plate retaining ring.

metric, so the tool can be used for the tilt/telescopic column.

This tool is available from HPC distributors. For a distributor near you, contact HPC at 708-671-6280.

Another slick little tool for making the job easier is the Clincher by Pro-Lok. (see *photograph 2.*) While originally designed to expedite the reassembly of GM face caps, this tool can be used on a variety of auto face caps provided they are similar in size

to the standard GM.

To use the tool, place an assembled lock with face cap into the Clincher, making sure that two of the cap's retaining tabs are in-line with the Clincher's handles. Then, with the lock in place, squeeze the handles.

In one easy motion the face cap tabs are pressed snugly into place. Open the handles and rotate the lock to position the two remaining tabs under the handles. Squeeze the handles to set the tabs. When complete the face cap is tight and secure.

For more information, contact Pro-Lok at 1060 N. Batavia Ste. G, Orange, CA, 92667, 714-633-0681.

Throughout 1994 *The National Locksmith* magazine has run articles generating a key for the Alpha Technologies ignition

used on the 1991 through 1994 Chevrolet Cavalier, and the 1992 through 1993 Oldsmobile Achieva, Buick Skylark, and Pontiac Grand Am.



2. The Pro-Lok "Clincher" makes fast, easy face cap replacement.



3. Saber Tool's AlphaCracker let's the locksmith generate Alpha Tech keys without disassembly.

Of highest interest is a tool that allows the locksmith to decode the lock without any disassembly.

Introduced almost a year and a half ago the AlphaCracker by Saber Tool Co. has done very well. (See photograph 3.) Utilizing a "pass/no pass" method for reading the wafer depths, this tool is extremely easy to use and read. The only factor in failing to generate a key using this tool seems to be operator error (outside of a damaged lock, that is).

In fact, according to Saber Tool manufacturer, Tom Mazzone, failure is typically caused by one of four reasons: Failure to read instructions, failure to practice, equipment failure and failure to execute properly.

While Mazzone points out that the first two conditions are the responsibility of the locksmith, he did offer some helpful tips regarding the equipment and execution problems.

1. In general it is not the equipment that fails, it is the inconsistent lock tolerances that make even a good key machine look bad. As a matter of practice, Mazzone recommends that punch machines not be used, or, if they are, the slopes of the cuts be filed flat from cut to cut. Better yet, the HPC 1200CM or Framon can be used to cut a laser style key. This normally makes up for the lock inconsistencies.

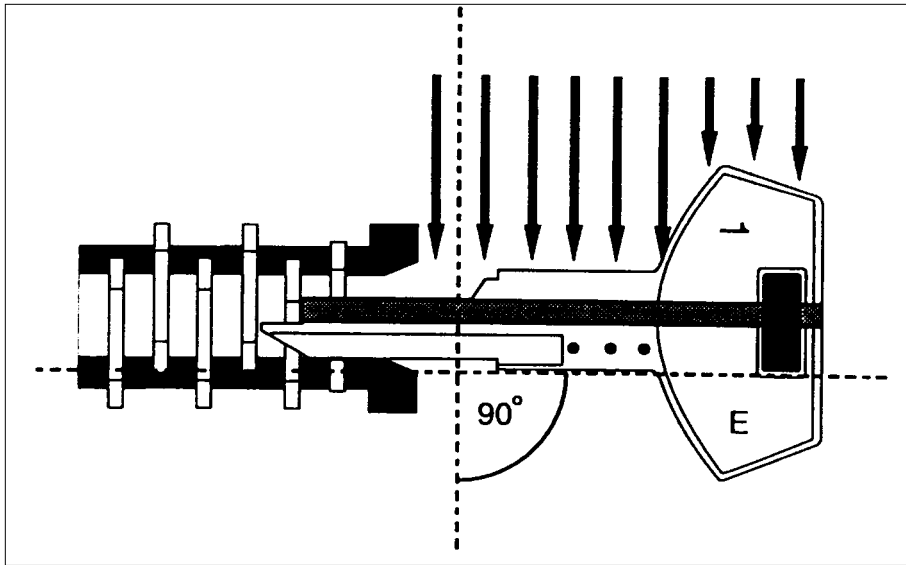

4. The uncut side of the depth key must be pushed against the lock's keyway.

and incorrect reading. (See illustration 4.)

4. The key must be perfectly parallel to the keyway. Tilting the key up or down allows it to slide beneath or slide into a wafer. This too gives incorrect readings. (See illustration 5.)

For pricing and delivery, contact Allied Lock & Supply at 800-544-2102. For technical information, contact Saber Tool Co. at 708-843-1017. 1 17

2. If you have trouble reading while moving the key from the front wafer to the back, start with the back wafer and move forward. Use the wafer slide to insert the key fully into the lock and then slowly slide the key out. Listen and feel for a tumbler to drop. If a tumbler can be heard or felt, double check by pushing the key forward into the wafer. If the key stops against the wafer, move onto the next deeper increment depth key for that tumbler.

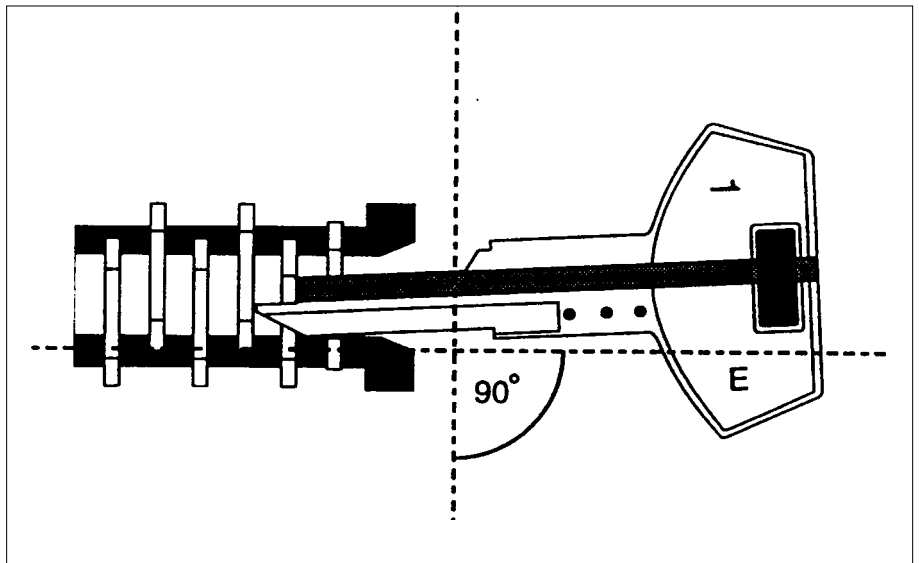

3. Make sure that the uncut side of the depth key is contacting the bottom/top side of the keyway. Because this is a double sided key there is a tendency for the tumblers not being measured to push the key up into the tumblers that are being measured. This, of course, makes for inconsistent

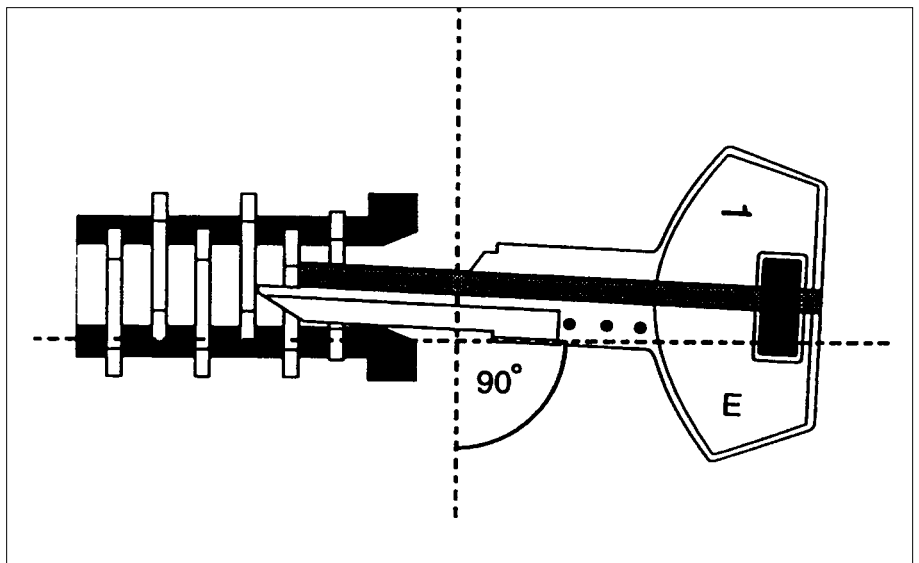

5. Any tilting of the depth key will render an incorrect reading.

Dale Does: High Tech Car Opening Tools

Every newsletter Dale will review a car opening and automotive tool manufacturer. This issue, Dale does High Tech.

By Dale Libby

With all the improvements that car manufacturers have made with regards to 'theft-proofing' their automobiles, the locksmith must be made aware of how to safely and quickly unlock and release car doors.

This information must be timely and easy to follow. The other component of a car opening system is to have the tools that will do the job. The High Tech tools do accomplish that easily and with a minimum of effort on your part. Let us first discuss the information materials part of the car opening set. (See photograph 1.)

The paper part of the 2200 car opening set is as its name implies, ENCYCLOPEDIA. The complete set comes with several books that I will list briefly:

1. The Automotive Encyclopedia

and Lockout Manual contains everything you wanted to know about opening cars, the correct tools and procedures to use, the original Briggs and Stratton lock part numbers, keying kits, lock rotation to open, space and depth charts, and VIN chart information just to mention a few of the benefits. The only thing that this manual does not contain are the actual car codes. Anything, and I mean anything,

else you would ever want to know is listed here.

If you had to carry this manual in your service vehicle, you would develop into a weight lifter. It is just too big and cumbersome (complete) to carry everywhere with you, so High Tech Tools has developed the (Once called Mini-Manuals) Field Manuals.

2. The field manuals come currently in 3 volumes. They are



1. The High Tech 2200 Car Opening set.

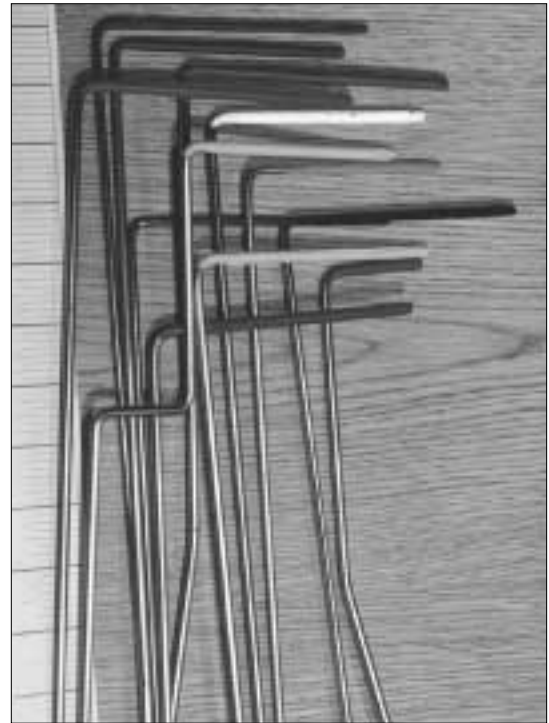

2. The tools are color coded to make selection easy.

broken down into American Cars in Volume 1; Foreign Vehicles, Trucks and Vans in Volume 2; and newer vehicles and trucks in the Field Manual / Encyclopedia Supplement.

These manuals are smaller and can be stored in the Optional High Tech Tool Carrying Case. They contain both graphical and pictorial methods of opening vehicles. The tool shown is listed by its part number and by a graphical picture, also listing the handle color (if applicable).

The drawings are complete enough in themselves to show the locksmith how to open any car. The pictures of an actual opening may help to clarify the correct placement of the tool on a real car door. Between the drawings and pictures in the field manual, no car will be locked for long.

3. Next, in the information highway, come several smaller volumes. One is about servicing Saturn cars. The next indispensable volume is the Automotive Lock Service Volume. In this book, procedures are listed and pictures shown for servicing many steering columns, both old and new styles of Ford, GM, and Chrysler.

Additional information covered in this Service Manual include the following:

- a. Lock Picking Methods
- b. Lock Impressioning
- c. Visual Lock and Key decoding
- d. Lock Progression charts for Ford, Chrysler, and GM
- e. Try out keys that you can cut

f. Steering column servicing for both old and new, including MATS and VATS/PASSKEY systems

g. A large section on Depth and Spacing for Foreign Keys Vehicles.

Also included a video tape library of car openings and steering wheel servicing including VATS/PASSKEY and MATS. The videos are well made and enhanced with computer generated graphics that repeatedly show how to open a vehicle.

The next part of the High Tech 2200 opening system to be discussed are the actual tools. These are well formed tools that will give years of good service. Simply put, they do what they say they will accomplish with a minimum of effort.

Another innovative part of the High Tech tools are the color coded handles. The instructions for opening the car in some instances will state use the RED handle, the GREEN handle, or the CLEAR handle. When the tools are in the tool pouch, it is easy to identify the tool you will need. (*See photograph 2.*)

With the advent of more and more tools being needed, High Tech has consolidated some tools, making one end for a specific car, and the opposite handle end effective on other cars. These tools are very distinctive and easy to recognize without color coding.

The next part of the hardware part of the kit include a set of SUPER WEDGES. There is a double wedge and two single wedges. These plastic wedges have a slot formed in their edges so one can insert a car

light to illuminate hard to find lock rods, linkages, bell cranks, and holes in the doors. These channels keep the wand of the light safe from pressure of the window against the door. How many times have we broken a light like this?

Last, but not least is the vinyl 'soft' carrying case. There are two large pockets for tools, and two smaller pockets to carry the field manuals. This is an excellent way to store the tools and manuals for ease of use; Everything under one cover.

As with any current car opening tool set, you must periodically have to update the set, both in the information and the hardware parts. Each year, High Tech Tools sends an update letter to registered users of their tools and manuals usually in early November.

There are several money saving options and goodies associated with the update notice. High Tech Tools not only can supply with quality locksmith tools and parts, it also has a printing service that can supply business cards, stationary, letterheads, and custom invoices and service stickers. For further information on ordering a tool set, to get on the mailing list, or just have questions, contact, High Tech Tools, Drawer 450370, Miami, Florida 33145. Or, call 800-323-8324. ¶

Opening The 1994 Honda Accord 2 Door

Three methods for opening this Honda.

By D. Scott Selby

Gone are the days when I could easily open any model at will and, generally, in only seconds. I remember when I could bet a service station owner that I could open any vehicle on his lot faster with my lockout tool than he could with the keys, as long as those keys started in his pocket. After winning many tanks of needed gas, I had proved my point several times over.

Recently, however, the auto makers have slowed me down with their newer, tougher lock system designs, allowing only those with highly researched technical manuals and the corresponding tools to even think about attempting a keyless entry.

I am convinced that the auto makers are on target with their small target lock system designs as this keeps the common stereo typical thief from easily entering our vehicles using anything from a coat hanger to a homemade flat bar tool. On the other hand, models designed today leave only just enough exposure for the professional to rescue the general public in a damage-free manner. (See photograph 1.)

I'm sure they intentionally leave

us (the professional lock-out technicians) this slight linkage exposure so that the general public has a practical remedy to their lockout situation, other than breaking an expensive window. Otherwise, 30,000 to 40,000 of us per day would be standing around unsafe street corners waiting for the original dealer to send a new key...not a situation I want my family to ever be in.

We will continue being able to open the vehicles now and into the future, but to easily open them is a thing of the past.

Before the 90's models, just about anyone could open most any model and would accept the job for the price of a taxi ride to arrive at the job site. All that has changed. Now only the well-trained technicians will survive the coming years, which means a much greater pay reward will surface from their continued education and experience. The fewer of us out in the field who can handle the new age of cars, the higher volume of calls we will receive along with higher pay per call due to a rapid swing of supply and demand.



1. The 1994 Honda Accord two door.

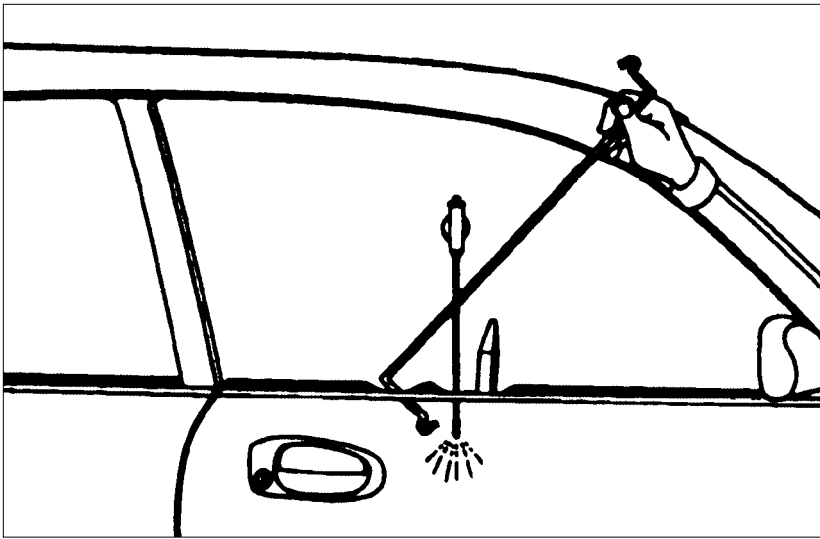

2. Unlike previous years, this Honda's linkage is well protected.

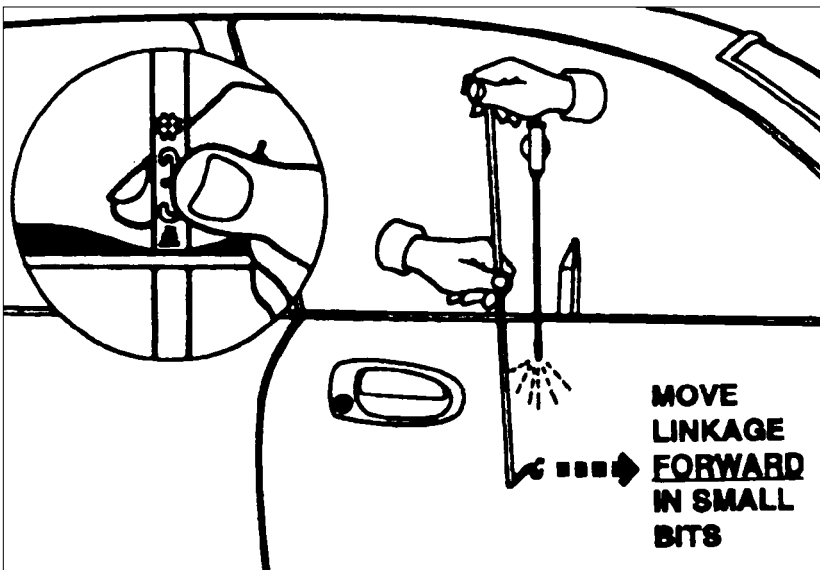

3. Inserting the Inverted Z-Tool.

Three ways to Open the 1994 Honda Accord (2 Door)

Method One

The linkage rods are well protected with a black plastic shield but there is approximately 1" of lock linkage exposure that can be contacted and moved to its position. The shield is directly behind and slightly below the outside door handle. (See illustration 2.)

Place large end of Flex-a-Wedge™ 4" forward of outside door handle. Use a probe light if you think you need extra help to locate the gap at the end of linkage shield which is where the linkage exposure is available.

Start by inserting the large end of the Inverted Z-Tool® 2" forward of the outside door handle. (See Illustration 3.)

- Pinch off the #3 depth guide and insert until depth matches weather-stripping.

- Make 1/4 turn counter-clockwise so hook swings under exposed lock linkage.
- Lift up on tool to hook linkage from below.
- In one motion, twist handle clockwise (to bind hook onto linkage) as you leverage the linkage forward to its unlocked position.

NOTE: Linkage exposure is so slight you will have to move linkage forward in small bits to fully move linkage to its opened position. Otherwise the tool shaft hits up against the adjacent sheet metal preventing the full travel of the lock linkage.

As you can see, the model requires precise positioning of the tool to grasp onto the only available section of the lock system. The depth guide aids tremendously in locating the exacting target.

Method Two

The target is a small bell crank mechanism. Pinch off at the #3 depth guide and insert large end of Z-Tool® directly above key cylinder. Keep trying to contact and push forward as it may require many attempts as it's tough.

Method Three

This was given to me by A-1 Locksmiths of Ashville, N.C. who says to use AutoBuster tool on the drivers door only if there is no after market window tinting installed.

D. Scott Selby is the researcher and developer of the Master Z-Tool System®. For more information contact: 800-336-8812. 

Top To Bottom Camry (Continued from Front Cover)

must, I use the super bright car opening light from Jiffy Model AL3900, it uses a 9.6 Makita rechargeable battery and is sold through Pro-Lok.

Ignition Lock

The ignition lock is located in the dash and has a large rubber ring that encircles the cylinder.

The rubber ring and plastic bezel just snap it off exposing the lock. (See photograph 3.) Now stop and disconnect the battery before proceeding.

Photograph four is a view from under the dash showing the bottom of the ignition cylinder housing where the ignition cylinder retainer is located. It is not necessary to depress the cylinder retainer from this position, I show it as a point of reference.

To remove the cylinder, first put the key in the ignition and turn it to the ACC or accessory position. Then depress the retainer by inserting a long narrow probe with a small 90° L-shaped hook on the end to reach in through the cylinder



2. Finding the open spot of lock linkage is tricky but not impossible.



3. Lock with rubber ring and plastic bezel removed.



4. The ignition housing is clearly seen from under the dash area. But, it is not necessary to remove the cylinder from this position.



5. Use an L-shaped probe to reach the cylinder retaining button and remove the ignition cylinder from the housing.

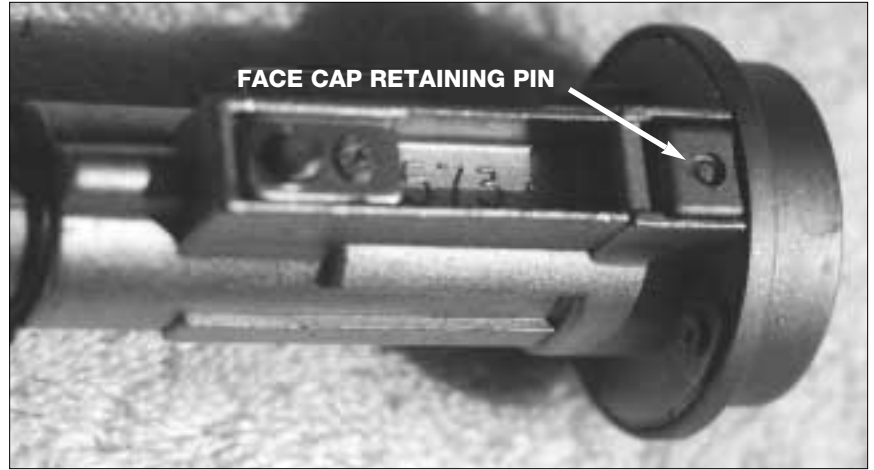

6. Drill and pry out this face cap retaining pin.

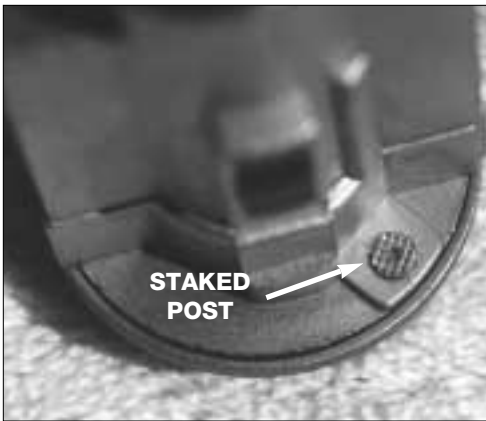

7. One of two staked posts that hold the face cap to the lock.



8. These vehicles utilize the Toyota split wafer system.



9. The door lock is integrated into the handle.



10. Start by removing the door latch release trim. Gently remove the bottom side first and then the top. This part breaks easily.

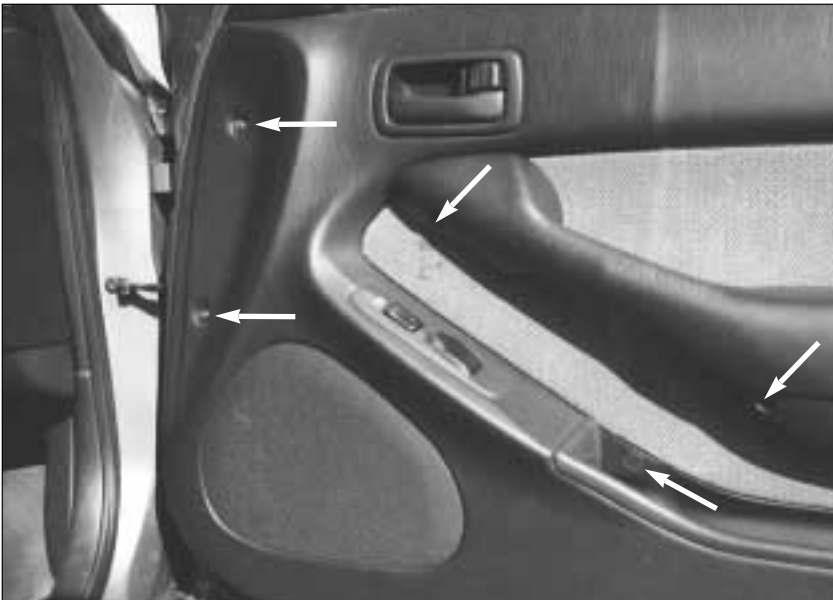

11. These screws and fasteners must be removed from the panel for its removal.

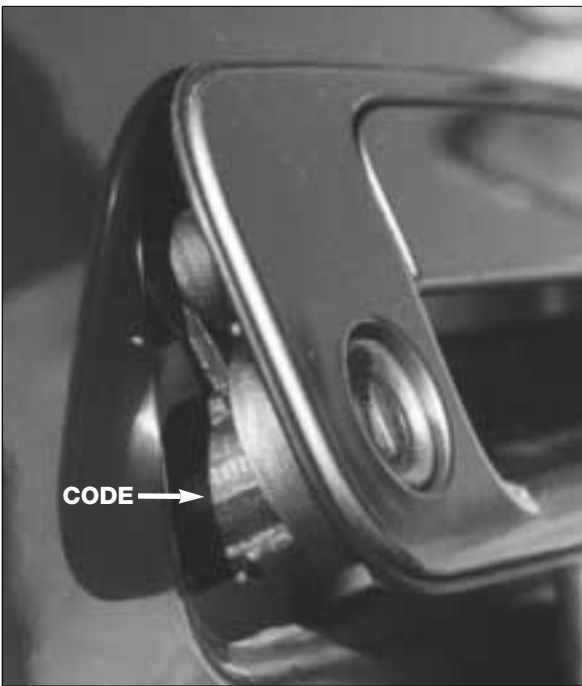
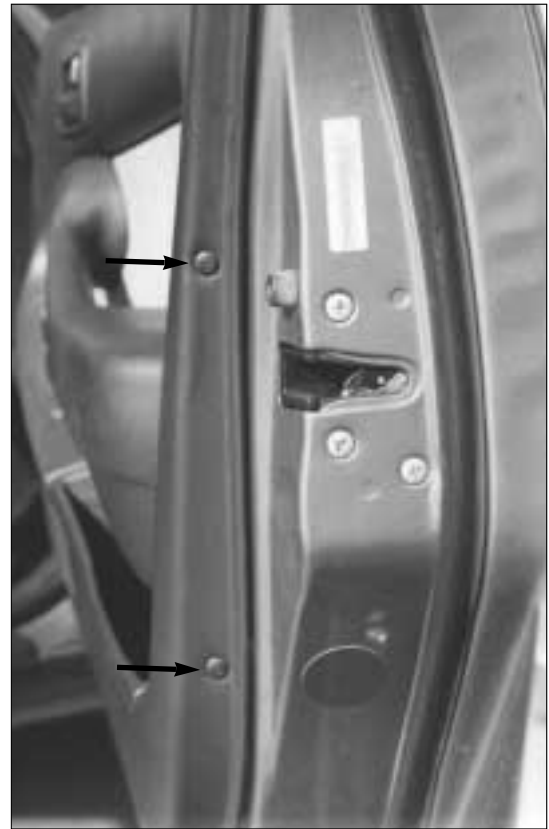

12. After removing the handle mounting screws, the key code can be seen by tilting the unit slightly out of the car.

hole opening in the dash and depress the retainer on the bottom side of the ignition housing. (See photograph 5.)

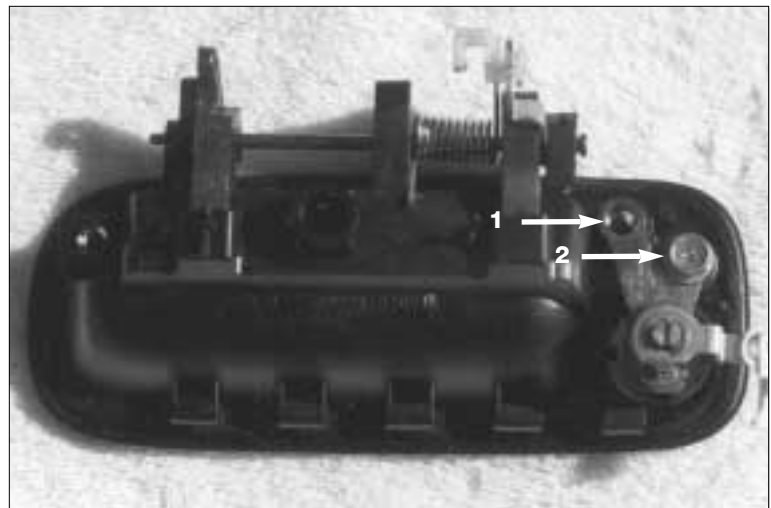

13. Arrow 1 shows the flange that makes it necessary to remove the handle before servicing the lock. Arrow 2 is the 10mm bolt that holds the lock to the handle.

The ignition face cap is held to the cylinder housing with a retaining pin and two staked posts.

To remove the pin, drill a small hole next to the pin and pry it out with a pin punch. (See photograph 6.)

Use a tru-arc ring spreader to remove the plug retaining ring from the rear of the ignition cylinder plug. Place the ignition cylinder housing in a vise with the face pointing downward and make it snug, but do not over tighten. There are two pot-metal posts that stick out of the

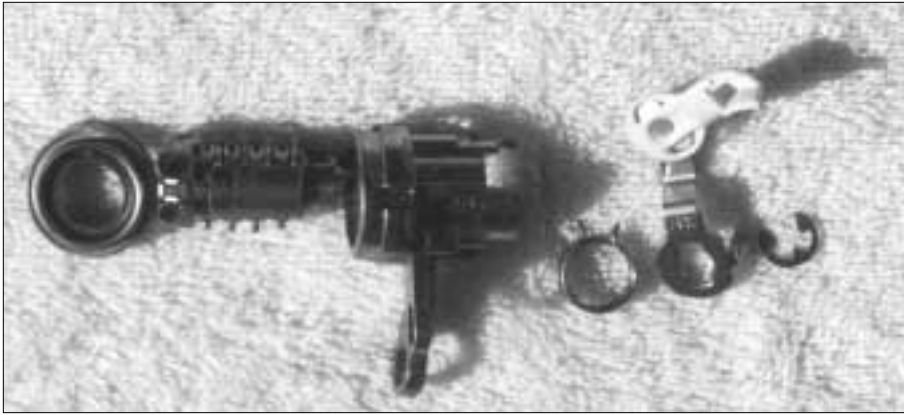

14. The disassembled door lock.



15. Location of the trunk lock.



16. This liner must be removed from the deck lid before gaining access to the light assembly and trunk lock.

ignition face-cap and through the cylinder housing that were staked in place at the factory. (See photograph 7.)

I have found that consistent, light blows to each post in succession will allow the posts to travel back through the cylinder housing without damage. If you are heavy handed, take your time to avoid breaking the posts.

These Toyota's use the new split tumblers mixed in with solid wafer-type tumblers. These split tumblers are always the same depth as it's opposing split tumbler, since they ride on the same landing. (See photograph 8.) I personally believe this is a bad design flaw, because as the edge of the key wears the landing will become smaller, thus the split tumblers will start to bind and not ride at their correct height.)

After you code the cylinder, place the cylinder face-cap in the face down position on a nonsharing surface and gently push the housing back onto the face-cap, it may be necessary to gently tap in place. Now that the face-cap is seated onto the cylinder housing you can re-stake the face cap posts.

Door Lock

The door lock cylinders on the Camry are integrated into the handle assembly. (See photograph 9.)

Start door panel removal by taking off the inside door latch release trim. (See photograph 10.) Insert a small screwdriver between the trim plate and the lever to allow for the trim plate to clear the retainer pin on the bottom section and repeat this



17. View of the trunk lock with the light section removed.

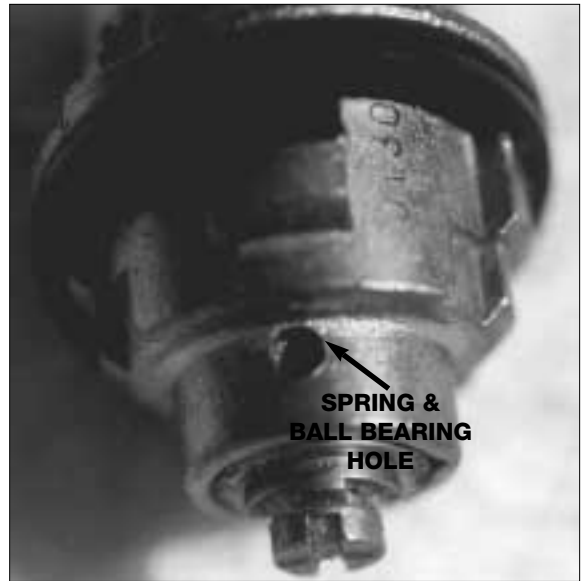

18. Be careful not to lose the ball bearing and spring located in the back of the lock's plug.



19. The disassembled lock.



20. Gently remove the plastic cover over the plug.

step for the top section. (I note the importance of this step in order to avoid breaking this trim piece, as I have done so in the past.)

Photograph 11 indicates the five screws that must be removed at the front part of the panel and the two trim fasteners located at the back of the panel. Simply push in on the center of the fastener plug and then pull out the fastener housing for removal.

The next task is to remove

the door panel and disconnect any electrical connections. You do not want to stretch them to the point that the wires snap or break. Gently pull back the inner panel plastic liner and remove the two 10mm bolts holding the handle assembly to the door skin. By pulling the

handle assembly out from the bottom it is easy to read the key code stamped on the side of the door cylinder. (See *photograph 12.*)

Because a mounting flange or tab on the lock lies between the vehicles body and the handle, it is necessary to remove the

whole handle to service the lock. If you disconnect the handle and lock linkage you can then easily remove the handle/lock assembly. (See *photograph 13.*) Remove the 10mm bolt that holds the lock cylinder to the handle assembly to separate lock from handle.

Photograph 14 shows the door lock cylinder completely disassembled.

Trunk Lock

The trunk lock cylinder, despite its appearance, is located in the deck lid and comes out the front. (See *photograph 15.*) The rear center taillight assembly must be removed to gain access to the cylinder. It is necessary to use a 7mm socket to remove the nuts that hold the light assembly in place.

These models are equipped with inside trunk and gas release levers.

Before the trunk lock can be removed a liner has to be removed to gain access to the taillight assembly and lock cylinder. (See *photograph 16.*) *Photograph 17* is a view of the light assembly set to the side.

The trunk lock cylinder is held in place by the standard horseshoe clip. Remove the clip and remove the lock. Before you disassemble the lock cylinder completely be cautious of the ball bearing in the rear section of the lock. (See *photograph 18.*) The lock cylinder is shown completely disassembled in *photograph 19.*

Glove Box Lock

To disassemble and remove the plug for servicing, pop off the plastic cap on the front of

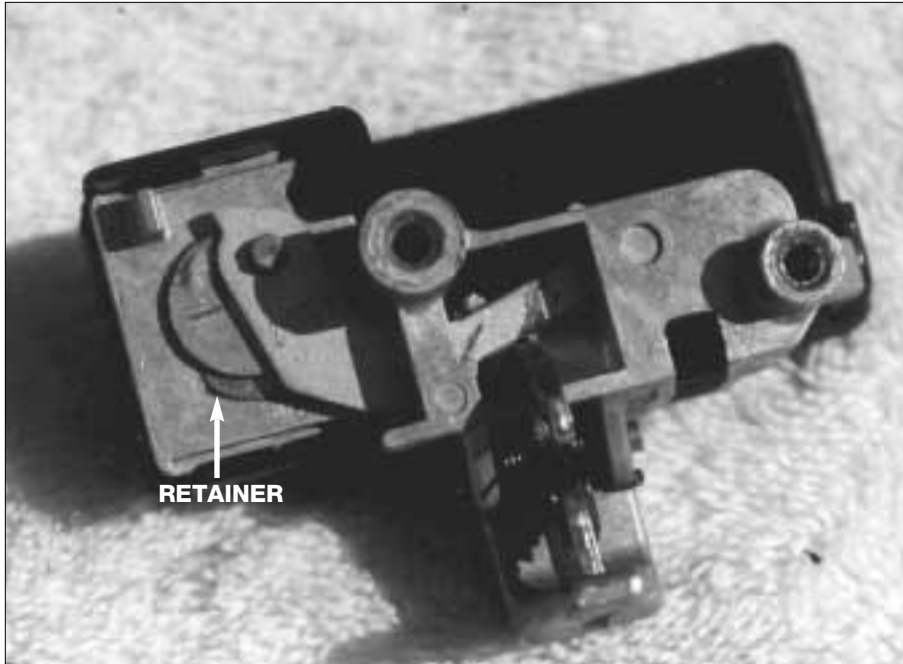

21. This retainer must be depressed for the plug to slide out the front of the lock.



22. The disassembled glove box lock.



23. The ASP pinning kit and Toyota split wafer system.

the lock. (See photograph 20.) The spring plug retainer tumbler must be depressed to slide the plug out the front. (See photograph 21.) Photograph 22 shows the lock disassembled for rekeying purposes.

Keying Kit & Tumblers

This model Toyota uses the Auto Security Products Keying Kit Number A30-108, using solid and split tumblers. The original tumblers are stamped with a depth number. (See photograph 23.)

Making First Key

To make a first key to the car:

Method #1: Remove the two 10mm bolts holding the passenger side door handle assembly and pull it outward at the bottom and read the code stamped on the side of the door cylinder lock.

Method #2: Remove a door or trunk cylinder and disassemble to decode the wafers to make a master key to the car.

Specifications

Tumbler Locations:

1	2	3	4	5	6	7	8	(Bow to Tip)
x	x	x	x	x	x	x	x	Ignition, Door, Trunk
				x	x	x	x	Glove Box

Code Series: 10000-15000

Key Blank: Iico X217/TR47 /Silca TOY43

HPC 1200CM Code Card: CF208

MACS: 2

Tip to center of first cut (Bow side): .883"

Cut to Cut: .090"

Depths: 1-.323", 2-.299", 3-.276", 4-.252"

Framon: Use Ford 5 PIN Spacing Clip. Set starting cut at .017" (First cut From Bow)

A Car By Any Other Name

Despite different manufacturers and names, many vehicles are identical and share similar key systems and service procedures.

By Tom Mazzone

Despite separate manufacturers and having different names, many vehicles are actually identical models with cosmetic differences. The Mercury Sable and Ford Taurus, for example, are identical vehicles using the same opening procedures and lock parts.

This method of operation is more predominant with GM than any other manufacturer, often producing similar vehicles that cross into two or more of their

motor divisions. To make servicing similar vehicles easy for their technicians, GM has classified service manuals and bulletins by the vehicle's body style.

For example, the late model Buick Skylark, Oldsmobile Achieva and Pontiac Grand AM are considered "N" body vehicles. They share similar frame and suspension packages, as well as many body parts. For the locksmith, these vehicles use

similar opening procedures, lock parts and keying systems, and key generation methods. In other words, if you have the information for one vehicle, you have it for the other vehicles that share the same body code.

For your convenience, following is a listing of all the GM body codes. Make your life and job easier by cross referencing the vehicles you are servicing. Good Luck. 

Passenger Vehicles

Buick	Century	1982-95	A
Chevrolet	Celebrity	1982-90	A
Oldsmobile	Cutlass Ciera/Wagon	1982-95	A
Pontiac	6000	1982-91	A
Chevrolet	Monte Carlo	1978-88	A, G
Buick	Roadmaster Sedan	1992-95	B
Buick	Roadmaster Wagon	1991-95*	B
Chevrolet	Caprice (Impala SS)	1991-95	B
Chevrolet	Caprice (Impala SS)	1980-90	B
Chevrolet	Impala	1980-85	B
Oldsmobile	Custom Cruiser (RWD)	1991-92	B
Oldsmobile	Custom Cruiser (RWD)	1980-90	B
Pontiac	Parisienne	1983-86	B
Pontiac	Safari	1987-89	B
Buick	Electra/LaSabre/ Estate Wagon (RWD)	1980-90	B, C, D
Oldsmobile	88/98 (RWD)	1980-90	B, C, D
Buick	Electra (FWD)	1985-90	C
Buick	Park Avenue/Ultra	1991-95	C
Buick	Park Avenue (FWD)	1985-90	C

Passenger Vehicles

Cadillac	DeVille (FWD)	1989-93	C
Cadillac	DeVille (FWD)	1985-88	C
Cadillac	Fleetwood (FWD)	1989-93	C
Cadillac	Fleetwood (FWD)	1985-88	C
Cadillac	Fleetwood Brougham (RWD)	1989-93	C
Cadillac	Fleetwood Brougham (RWD)	1985-88	C
Oldsmobile	98 Regency (FWD)	1991-95	C
Oldsmobile	98 Regency (FWD)	1985-90	C
Cadillac	DeVille (RWD)	1980-84	C, D
Buick	Reatta	1988-91	E
Buick	Riviera	1986-93	E
Cadillac	Eldorado	1992-95	E
Cadillac	Eldorado	1986-91	E
Oldsmobile	Toronado	1990-92	E
Oldsmobile	Toronado	1986-89	E
Chevrolet	Camaro	1993-95	F
Chevrolet	Camaro	1982-92	F
Pontiac	Firebird	1993-95	F
Pontiac	Firebird	1982-92	F

Passenger Vehicles

Pontiac	TransAm	1993-95	F
Pontiac	TransAm	1982-92	F
Buick	Riviera	1995	G
Oldsmobile	Cutlass Calais (RWD)	1982-88	G
Oldsmobile	Cutlass Supreme (RWD)	1982-88	G
Oldsmobile	Aurora	1995	G
Buick	LeSabre (FWD)	1992-95	H
Buick	LeSabre (FWD)	1986-91	H
Oldsmobile	Eighty Eight Royale/LS/LSS	1992-95	H
Oldsmobile	Delta 88 Royale (FWD)	1986-91	H
Pontiac	Bonneville (FWD)	1992-95	H
Pontiac	Bonneville (FWD)	1987-91	H
Buick	Skyhawk	1988-89	J
Cadillac	Cimarron	1982-88	J
Chevrolet	Cavalier	1995*	J
Chevrolet	Cavalier	1988-94	J
Oldsmobile	Firenza	1988	J
Pontiac	Sunbird	1988-94	J
Pontiac	Sunfire	1995*	J
Pontiac	Tempest† (Canada)	1987-94	J
Geo	Tracker	1989-95*	J1, 2
Cadillac	Seville	1992-95	K
Cadillac	Seville	1986-91	K
Cadillac	DeVille/Concours	1994-95	K
Chevrolet	Beretta	1987-95	L
Chevrolet	Corsica/Tempest†	1987-95	L
Chevrolet	Sprint/Firefly, † Canada-Only	1985-88	M
Geo	Metro	1995*	M
Geo	Metro/Sprint	1989-94	M
Pontiac	Firefly (Canada)	1985-88	M
Buick	Skylark	1992-95	N
Buick	Skylark	1986-91	N
Buick	Somerset	1985-89	N
Oldsmobile	Cutlass Calais (FWD)	1985-91	N
Oldsmobile	Achieva	1992-95	N
Pontiac	Grand Am (FWD)	1992-95	N
Pontiac	Grand Am (FWD)	1985-91	N
Pontiac	Fiero	1984-88	P
Chevrolet	Spectrum/Sunburst	1985-89	R
Geo	Spectrum/Sunburst	1985-89	R
Geo	Storm	1990-93	R
Chevrolet	Nova	1985-88	S
Geo	Prizm	1993-95*	S
Geo	Prizm	1989-92	S
Oldsmobile	Bravada	1991-94	S, T
Pontiac	LeMans (FWD)	1988-93	T
Pontiac	Optima (Canada)	1988-93	T
Chevrolet	Lumina APV	1990-95*	U
Oldsmobile	Silhouette	1990-95*	U

Passenger Vehicles

Pontiac	Trans Sport	1990-95*	U
Cadillac	Allante	1987-93	V
Buick	Regal Coupe (FWD)	1988-95*	W
Buick	Regal Sedan (FWD)	1991-95*	W
Chevrolet	Lumina/Monte Carlo	1995	W
Chevrolet	Lumina Coupe/Sedan	1990-94	W
Oldsmobile	CutlassSupreme Coupe (FWD) (Includes Convertible)	1988-95*	W
Oldsmobile	Cutlass Supreme Sedan (FWD)	1990-95*	W
Pontiac	Grand Prix Coupe (FWD)	1988-95*	W
Pontiac	Grand Prix Sedan (FWD)	1990-95*	W
Chevrolet	Corvette	1984-95	Y

Trucks & Vans

Blazer/Jimmy/Bravada/Yukon Full Size Chev/GMC	1987-91	R, V
Blazer/Jimmy/Bravada/Yukon Full Size Chev/GMC	1978-86	C, K
Blazer/Jimmy/Bravada/Yukon Blazer/Yukon	1992-95*	C, K
Blazer/Jimmy/Bravada/Yukon Blazer/Jimmy	1995	S, T
Blazer/Jimmy/Bravada/Yukon S10/S15/Bravada (Includes Typhoon)	1983-94	S, T
Truck-Pickup Full Size Chev/GMC	1978-86	C, K
Truck-Pickup Full Size Chev/GMC (VIN Code C, K)	1988-91	C, K
Truck-Pickup Full Size Chev/GM	1992-95*	C, K
Truck-Pickup Full Size Chev/GMC	1987	R, V
Truck-Pickup Full Size Chev/GMC (VIN Code R, V)	1988-91	R, V
Truck-Pickup Suburban	1992-95*	C, K
Truck-Pickup Suburban	1987-91	R, V
Truck-Pickup Suburban	1978-86	C, K
Truck-Pickup S10/Sonoma Pickup	1994-95	S, T
Truck-Pickup S10/S15/Sonoma (Includes Cyclone)	1982-93	S, T
Vans Full Size Chev/GMC	1978-95	G
Vans Astro/Safari	1985-95*	M
Vans APV Lumina/Silhouette/Trans Sport	1990-95*	U

(FWD) – Front Wheel Drive

(RWD) – Rear Wheel Drive

† See Chevrolet Corsica Information

* Indicates New or Updated Information