

# ALTO-SHAAM®

## Carving Station



CS-200 with Breath Guard

### **Models:**

**CS-100**

**CS-200**



CS-100 with Breath Guard

- **INSTALLATION**
- **OPERATION**
- **MAINTENANCE**

**HALO**  
**HEAT®**

**24•7**  
Your Service Hotline  
1-800-558-8744

W164 N9221 Water Street • P.O. Box 450 • Menomonee Falls, Wisconsin 53052-0450 USA  
PHONE: 262.251.3800 • 800.558.8744 USA/CANADA FAX: 262.251.7067 • 800.329.8744 U.S.A. ONLY  
[www.alto-shaam.com](http://www.alto-shaam.com)

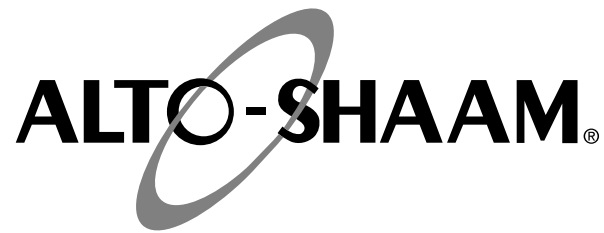

Delivery .....	1
Unpacking .....	1
Safety Procedures and Precautions .....	2

**Installation**

Installation Requirements .....	3
Leveling .....	3
Dimension Drawings, CS-100 .....	4
Dimension Drawings, CS-200 .....	5
Electrical Connection .....	6

**Operation**

User Safety .....	7
Start-Up .....	7
Operating Procedures .....	7
General Holding Guidelines .....	8

**Care and Cleaning**

Protecting Stainless Steel Surfaces .....	9
Cleaning Agents .....	9
Cleaning Materials .....	9
Equipment Care .....	10
Clean Daily .....	10
Sanitation .....	11

**Service**

Service View, CS-100 .....	12
Service View Parts List, CS-100 .....	13
Service View, CS-200 .....	14
Service View Parts List, CS-200 .....	15

**Wiring Diagrams**

Always refer to the wire diagram(s) included with the unit for most current version.

**Warranty**

Transportation Damage and Claims .....	.Back Cover
Limited Warranty .....	.Back Cover

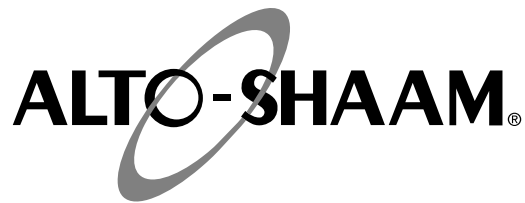

## DELIVERY

This Alto-Shaam appliance has been thoroughly tested and inspected to ensure only the highest quality unit is provided. Upon receipt, check for any possible shipping damage and report it at once to the delivering carrier. *See Transportation Damage and Claims section located in this manual.*

This appliance, complete with unattached items and accessories, may have been delivered in one or more packages. Check to ensure that all standard items and options have been received with each model as ordered.

Save all the information and instructions packed with the appliance. Complete and return the warranty card to the factory as soon as possible to ensure prompt service in the event of a warranty parts and labor claim.

This manual must be read and understood by all people using or installing the equipment model. Contact the Alto-Shaam Tech Team Service Department if you have any questions concerning installation, operation, or maintenance.

**NOTE:** All claims for warranty must include the full model number and serial number of the unit.

## UNPACKING

1. Carefully remove the appliance from the carton or crate.

**NOTE:** Do not discard the carton and other packaging material until you have inspected the unit for hidden damage and tested it for proper operation.

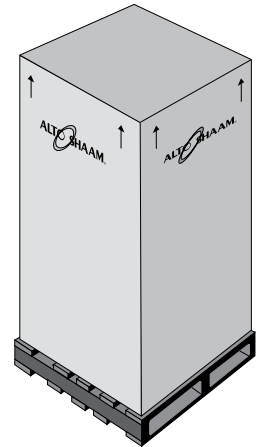

2. Read all instructions in this manual carefully before initiating the installation of this appliance.

**DO NOT DISCARD THIS MANUAL.**

This manual is considered to be part of the appliance and is to be provided to the owner or manager of the business or to the person responsible for training operators. *Additional manuals are available from the Alto-Shaam Tech Team Service Department.*

3. Remove all protective plastic film, packaging materials, and accessories from the appliance before connecting electrical power. Store any accessories in a convenient place for future use.

# SAFETY PROCEDURES AND PRECAUTIONS

Knowledge of proper procedures is essential to the safe operation of electrically and/or gas energized equipment. In accordance with generally accepted product safety labeling guidelines for potential hazards, the following signal words and symbols may be used throughout this manual.

<b>DANGER</b>	
	<b>Used to indicate the presence of a hazard that WILL cause severe personal injury, death, or substantial property damage if the warning included with this symbol is ignored.</b>

<b>WARNING</b>	
	<b>Used to indicate the presence of a hazard that CAN cause personal injury, possible death, or major property damage if the warning included with this symbol is ignored.</b>

<b>CAUTION</b>	
	<b>Used to indicate the presence of a hazard that can or will cause minor or moderate personal injury or property damage if the warning included with this symbol is ignored.</b>

<b>CAUTION</b>	
<b>Used to indicate the presence of a hazard that can or will cause minor personal injury, property damage, or a potential unsafe practice if the warning included with this symbol is ignored.</b>	

<b>NOTE:</b> Used to notify personnel of installation, operation, or maintenance information that is important but not hazard related.
--

1. This appliance is intended to cook, hold or process foods for the purpose of human consumption. No other use for this appliance is authorized or recommended.
2. This appliance is intended for use in commercial establishments where all operators are familiar with the purpose, limitations, and associated hazards of this appliance. Operating instructions and warnings must be read and understood by all operators and users.
3. Any troubleshooting guides, component views, and parts lists included in this manual are for general reference only and are intended for use by qualified technical personnel.
4. This manual should be considered a permanent part of this appliance. This manual and all supplied instructions, diagrams, schematics, parts lists, notices, and labels must remain with the appliance if the item is sold or moved to another location.

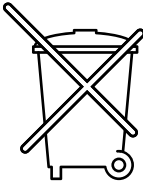
<b>NOTE</b>	
	<b>For equipment delivered for use in any location regulated by the following directive: DO NOT DISPOSE OF ELECTRICAL OR ELECTRONIC EQUIPMENT WITH OTHER MUNICIPAL WASTE.</b>

# INSTALLATION

## SITE INSTALLATION

### DANGER



IMPROPER INSTALLATION, ALTERATION, ADJUSTMENT, SERVICE, OR MAINTENANCE COULD RESULT IN SEVERE INJURY, DEATH, OR CAUSE PROPERTY DAMAGE.

READ THE INSTALLATION, OPERATING AND MAINTENANCE INSTRUCTIONS THOROUGHLY BEFORE INSTALLING OR SERVICING THIS EQUIPMENT.

### CAUTION



METAL PARTS OF THIS EQUIPMENT BECOME EXTREMELY HOT WHEN IN OPERATION. TO AVOID BURNS, ALWAYS USE HAND PROTECTION WHEN OPERATING THIS APPLIANCE.

### CAUTION



TO PREVENT PERSONAL INJURY, USE CAUTION WHEN MOVING OR LEVELING THIS APPLIANCE.

### CAUTION



The performance of this unit has been optimized using the factory provided bulbs. These bulbs should be replaced with an exact replacement or with a factory recommended replacement. These bulbs have been treated to resist breakage and must be replaced with similarly treated bulbs in order to maintain compliance with NSF standards. **DO NOT** over-tighten bulbs in their receptacles as this can cause damage to the bulb filament.

## SITE INSTALLATION

1. The appliance, complete with unattached items and accessories, may be delivered in one or more packages. Check to ensure all accessories ordered have been received.
2. The hot carving station is designed to be mounted directly on top of a Halo Heat Cook & Hold oven or holding cabinet. The shelf can also be used as a free-standing unit.  
**HEATED CABINET MOUNTED SHELVES:**  
Remove the 1" legs prior to placing the carving shelf on top of the Halo Heat cook/hold oven or holding cabinet. Appliance must be installed on a stable and level surface.  
**FREE-STANDING SHELVES:**  
Ensure that the 1" legs are in place prior to placing the carving shelf on work surface. Failure to operate without the 1" legs prior to heating the shelf could result in damage to the surface on which the shelf is placed, may pose a potential fire hazard, and nullifies the validity of the UL listing mark. Appliance must be installed on a stable and level surface.
3. **DO NOT** install this appliance in any area where it may be affected by any adverse conditions such as steam, grease, dripping water, high temperatures, or any other severely adverse conditions.

4. **DO NOT** install near a cold air source such as a freezer, air conditioning vents, or in any area where outside air fluctuation can affect performance.
5. This appliance must be kept free and clear of any obstructions blocking access for maintenance or service.
6. Lift Breath Guard up and slide into place in brackets found in the front of the appliance.

A number of adjustments are associated with initial installation and start-up. Installation and start-up adjustments are the responsibility of the dealer or user. These adjustments include but are not limited to leveling, electrical hook-up and installation of bulbs.

### LEVELING

Level the appliance from side-to-side and front-to-back with the use of a spirit level.



**NOTE:** Failure to properly level this appliance can cause improper function.

# INSTALLATION

## SITE INSTALLATION

**CS-100**

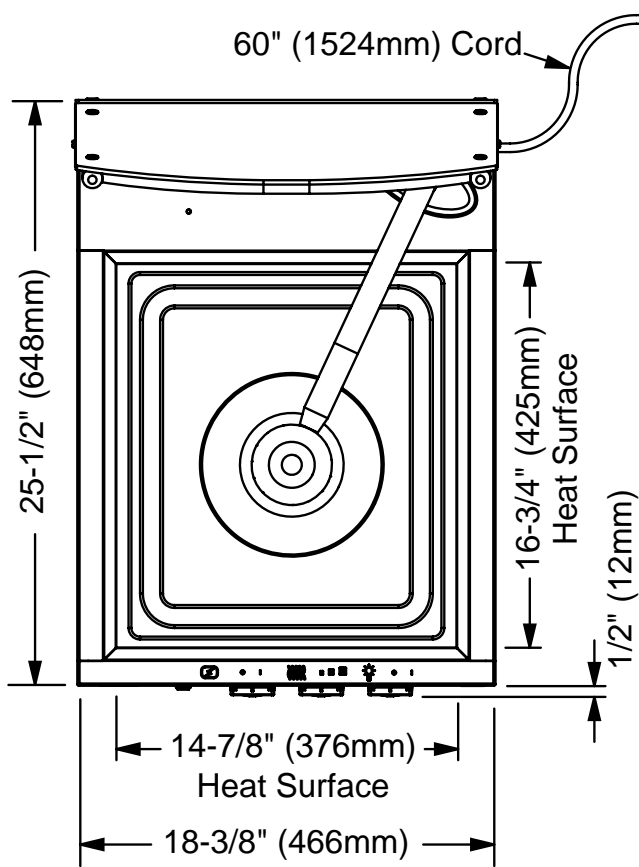

<b>HEATED PRODUCT CAPACITY</b>	
Weight (lbs) MAX.	40
Weight (kg) MAX.	18
Meat Size	SMALL STEAMSHIP ROUND

<b>OPTIONS AND ACCESSORIES</b>	
Carving Board	BA-28482
Carving Holder - Prime Rib	HL-2635
Carving Holder - Steamship	4459

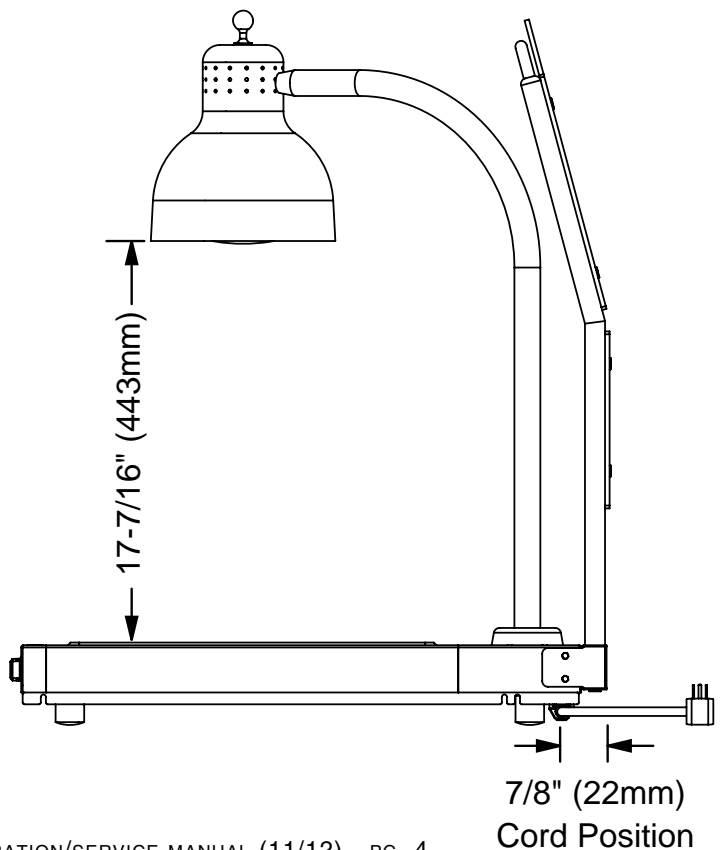
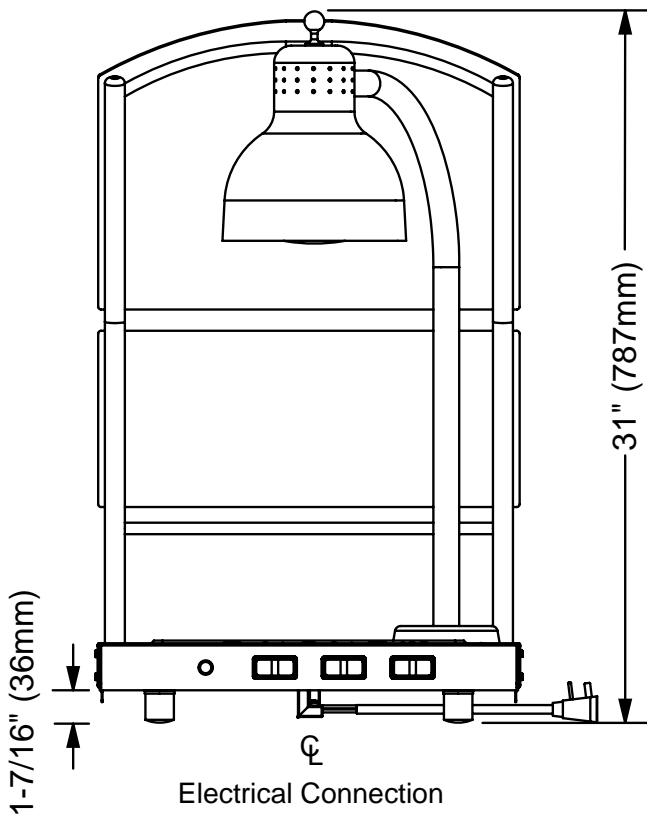

# INSTALLATION

## SITE INSTALLATION

### CS-200

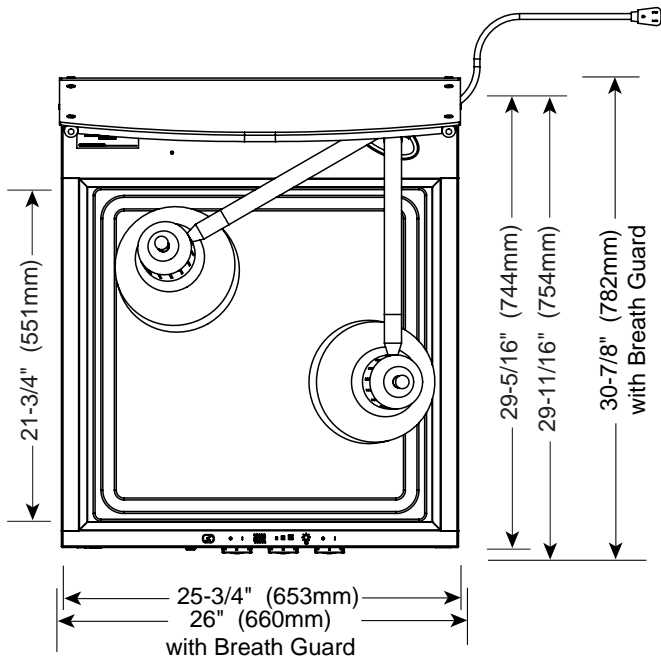

### HEATED PRODUCT CAPACITY

Weight (lbs) MAX.	70
Weight (kg) MAX.	31.7
Meat Size	LARGE STEAMSHIP ROUND

### OPTIONS AND ACCESSORIES

Full-Size Carving Board	BA-28066
Half-Size Carving Board	BA-29244
Carving Holder - Prime Rib	HL-2635
Carving Holder - Steamship	4459

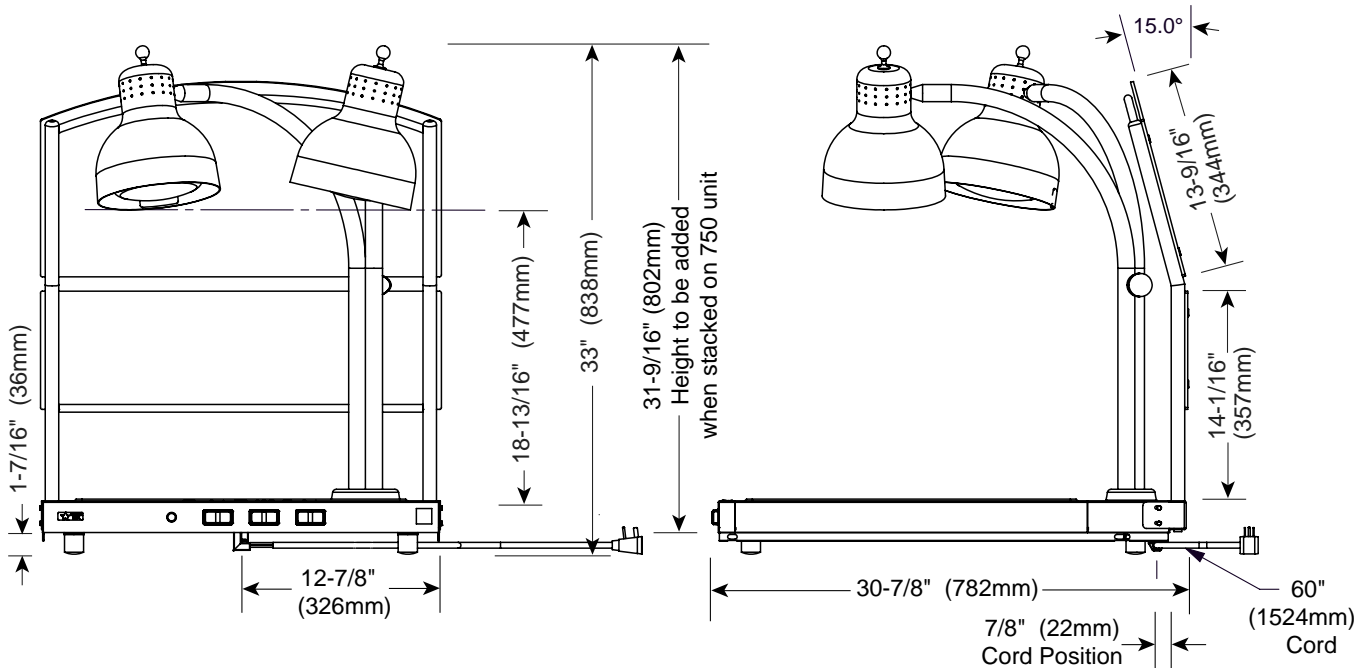

# INSTALLATION

## ELECTRICAL CONNECTION



### DANGER



**ELECTRICAL CONNECTIONS MUST BE MADE BY A QUALIFIED SERVICE TECHNICIAN IN ACCORDANCE WITH APPLICABLE ELECTRICAL CODES.**



### DANGER



**ENSURE POWER SOURCE MATCHES VOLTAGE IDENTIFIED ON APPLIANCE RATING TAG.**

1. An identification tag is permanently mounted on the carving station.
2. If necessary, a proper receptacle or outlet configuration as required for this unit, must be installed by a licensed electrician in accordance with applicable, local electrical codes.
3. Plug carving station into a properly grounded receptacle **ONLY**, positioning the unit so the power supply cord is easily accessible in case of an emergency. Arcing will occur when connecting or disconnecting the unit unless all controls are in the "OFF" position.

### DANGER



**To avoid electrical shock, this appliance **MUST** be adequately grounded in accordance with local electrical codes or, in the absence of local codes, with the current edition of the National Electrical Code ANSI/NFPA No. 70. In Canada, all electrical connections are to be made in accordance with CSA C22.1, Canadian Electrical Code Part 1 or local codes.**



**NOTE:** Where local codes and CE regulatory requirements apply, appliances must be connected to an electrical circuit that is protected by an external GFCI outlet.

**For CE approved units:** To prevent an electrical shock hazard between the appliance and other appliances or metal parts in close vicinity, an equalization-bonding stud is provided. An equalization bonding lead must be connected to this stud and the other appliances / metal parts to provide sufficient protection against potential difference. The terminal is marked with the following symbol.



### DANGER



**IMPROPER INSTALLATION, ALTERATION, ADJUSTMENT, SERVICE, OR MAINTENANCE COULD RESULT IN SEVERE INJURY, DEATH, OR CAUSE PROPERTY DAMAGE.**

**READ THE INSTALLATION, OPERATING AND MAINTENANCE INSTRUCTIONS THOROUGHLY BEFORE INSTALLING OR SERVICING THIS EQUIPMENT.**

ELECTRICAL - CS-100						
VOLTAGE	PHASE	CYCLE/HZ	AMPS	kW		CORD & PLUG
120	1	60	4.2	.50		NEMA 5-15P 15A - 125V Plug
230	1	50/60	2.2	.50		CEE 7/7, 220-230V PLUG

ELECTRICAL - CS-200						
VOLTAGE	PHASE	CYCLE/HZ	AMPS	kW		CORD & PLUG
120	1	60	6.3	.75		NEMA 5-15P 15A - 125V Plug
230	1	50/60	3.3	.75		CEE 7/7, 220-230V PLUG

Wire diagrams are located on the bottom outside of the unit.



# OPERATION

## USER SAFETY INFORMATION

### USER SAFETY INFORMATION:

This appliance is intended for use in commercial establishments by qualified personnel who are familiar with the purpose, limitations, and associated hazards of this appliance. Operating instructions and warnings must be read and understood by all operators and users.

## CAUTION



**METAL PARTS OF THIS EQUIPMENT BECOME EXTREMELY HOT WHEN IN OPERATION. TO AVOID BURNS, ALWAYS USE HAND PROTECTION WHEN OPERATING THIS APPLIANCE.**

## START UP

### BEFORE INITIAL USE:

Clean the metal surface exterior of the appliance with a damp cloth and mild soap solution. Rinse well.

Clean the glass breath guard with soap or mild detergent and water. Dry with a clean, damp chamois. Grease and oil may be removed with naphtha or hexane. Do not use commercial or household cleaners containing ammonia. To avoid scratching, do not use dry cloths or scouring compounds.



## DANGER



**DISCONNECT UNIT FROM POWER SOURCE BEFORE CLEANING OR SERVICING.**

## OPERATING PROCEDURES

### 1. Set toggle switch.

Press toggle switch for heated surface to "ON" position. Set 3-way toggle switch to desired holding temperature (LOW/MED/HIGH). Press toggle switch for lamps to "ON" position.

### 2. Preheat.

Preheat for a minimum of 30 minutes.

### 3. Transfer hot foods to the carving station.

The product must be at the proper internal temperature before transferring food to the carving station. Use a pocket-type meat thermometer to check the internal temperature of the product being held. Adjust the shelf temperature to give the best overall setting based on the internal product temperature. If any food product is not at proper serving temperature, use a Halo Heat Cook & Hold Oven or Combitherm® CombiOven to bring the product within the correct temperature range.

### 4. Check food temperature.

Since proper temperature range depends on the type of products and the quantities being held, it is necessary to periodically use a pocket thermometer to check each item to make certain the correct temperatures are being maintained. Local health regulations may vary regarding minimum serving temperatures. Proper temperature range is 140° to 160°F (60° to 71°C) or higher.

#### AVERAGE Heat Plate Temperature:

Setting	Temperature
Low	127°F (53°C)
Med	160°F (71°C)
High	180°F (82°C)

**NOTE: Do NOT use knives or utensils on the hot metal surface. A cutting board is supplied.**

# OPERATION

## GENERAL HOLDING GUIDELINES

Chefs, cooks and other specialized food service personnel employ varied methods of cooking. Proper holding temperatures for a specific food product must be based on the moisture content of the product, product density, volume, and proper serving temperatures. Safe holding temperatures must also be correlated with palatability in determining the length of holding time for a specific product.

Halo Heat maintains the maximum amount of product moisture content without the addition of water, water vapor, or steam. Maintaining maximum natural product moisture preserves the natural flavor of the product and provides a more genuine taste. In addition to product moisture retention, the gentle properties of Halo Heat maintain a consistent temperature throughout the cabinet without the necessity of a heat distribution fan, thereby preventing further moisture loss due to evaporation or dehydration.

When product is removed from a high temperature cooking environment for immediate transfer into equipment with the lower temperature required for hot food holding, condensation can form on the outside of the product and on the inside of plastic containers used in self-service applications. Allowing the product to release the initial steam and heat produced by high temperature cooking can alleviate this condition. To preserve the safety and quality of freshly cooked foods however, a maximum of 1 to 2 minutes must be the only time period allowed for the initial heat to be released from the product.

Use a metal-stemmed thermometer to measure the internal temperature of the product being held. Adjust the thermostat setting to achieve the best overall setting based on internal product temperature.

HOLDING TEMPERATURE RANGE		
MEAT	FAHRENHEIT	CELSIUS
BEEF ROAST — Rare	130°F	54°C
BEEF ROAST — Med/Well Done	155°F	68°C
BEEF BRISKET	160° — 175°F	71° — 79°C
CORN BEEF	160° — 175°F	71° — 79°C
PASTRAMI	160° — 175°F	71° — 79°C
PRIME RIB — Rare	130°F	54°C
STEAKS — Broiled/Fried	140° — 160°F	60° — 71°C
RIBS — Beef or Pork	160°F	71°C
VEAL	160° — 175°F	71° — 79°C
HAM	160° — 175°F	71° — 79°C
PORK	160° — 175°F	71° — 79°C
LAMB	160° — 175°F	71° — 79°C
POULTRY		
CHICKEN — Fried/Baked	160° — 175°F	71° — 79°C
DUCK	160° — 175°F	71° — 79°C
TURKEY	160° — 175°F	71° — 79°C
GENERAL	160° — 175°F	71° — 79°C
FISH/SEAFOOD		
FISH — Baked/Fried	160° — 175°F	71° — 79°C
LOBSTER	160° — 175°F	71° — 79°C
SHRIMP — Fried	160° — 175°F	71° — 79°C
BAKED GOODS		
BREADS/ROLLS	120° — 140°F	49° — 60°C
MISCELLANEOUS		
CASSEROLES	160° — 175°F	71° — 79°C
DOUGH — Proofing	80° — 100°F	27° — 38°C
EGGS — Fried	150° — 160°F	66° — 71°C
FROZEN ENTREES	160° — 175°F	71° — 79°C
HORS D'OEUVRES	160° — 180°F	71° — 82°C
PASTA	160° — 180°F	71° — 82°C
PIZZA	160° — 180°F	71° — 82°C
POTATOES	180°F	82°C
PLATED MEALS	140° — 165°F	60° — 74°C
SAUCES	140° — 200°F	60° — 93°C
SOUP	140° — 200°F	60° — 93°C
VEGETABLES	160° — 175°F	71° — 79°C
<b>THE HOLDING TEMPERATURES LISTED ARE SUGGESTED GUIDELINES ONLY. ALL FOOD HOLDING SHOULD BE BASED ON INTERNAL PRODUCT TEMPERATURES. ALWAYS FOLLOW LOCAL HEALTH (HYGIENE) REGULATIONS FOR ALL INTERNAL TEMPERATURE REQUIREMENTS.</b>		

# CARE AND CLEANING

## CLEANING AND PREVENTATIVE MAINTENANCE

### PROTECTING STAINLESS STEEL SURFACES



It is important to guard against corrosion in the care of stainless steel surfaces. Harsh, corrosive, or inappropriate chemicals can completely destroy the protective surface layer of stainless steel. Abrasive

pads, steel wool, or metal implements will abrade surfaces causing damage to this protective coating and will eventually result in areas of corrosion. Even water, particularly hard water that contains high to moderate concentrations of chloride, will cause oxidation and pitting that result in rust and corrosion. In addition, many acidic foods spilled and left to remain on metal surfaces are contributing factors that will corrode surfaces.





Proper cleaning agents, materials, and methods are vital to maintaining the appearance and life of this appliance. Spilled foods should be removed and the area wiped as soon as possible but at the very least, a minimum of once a day. Always thoroughly rinse surfaces after using a cleaning agent and wipe standing water as quickly as possible after rinsing.

### CLEANING AGENTS

Use non-abrasive cleaning products designed for use on stainless steel surfaces. Cleaning agents must be chloride-free compounds and must not contain quaternary salts. Never use hydrochloric acid (muriatic acid) on stainless steel surfaces. Always use the proper cleaning agent at the manufacturer's recommended strength. Contact your local cleaning supplier for product recommendations.

### CLEANING MATERIALS

The cleaning function can usually be accomplished with the proper cleaning agent and a soft, clean cloth. When more aggressive methods must be employed, use a non-abrasive scouring pad on difficult areas and make certain to scrub with the visible grain of surface metal to avoid surface scratches. Never use wire brushes, metal scouring pads, or scrapers to remove food residue.

 <b>CAUTION</b>	
 NO SCRAPERS	<b>TO PROTECT STAINLESS STEEL SURFACES, COMPLETELY AVOID THE USE OF ABRASIVE CLEANING COMPOUNDS, CHLORIDE BASED CLEANERS, OR CLEANERS CONTAINING QUATERNARY SALTS. NEVER USE HYDROCHLORIC ACID (MURIATIC ACID) ON STAINLESS STEEL. NEVER USE WIRE BRUSHES, METAL SCOURING PADS OR SCRAPERS.</b>
 NO WIRE BRUSHES	
 NO STEEL PADS	

# CARE AND CLEANING

## EQUIPMENT CARE

The cleanliness and appearance of this equipment will contribute considerably to operating efficiency and savory, appetizing food. Good equipment that is kept clean works better and lasts longer.



## THOROUGHLY CLEAN THE APPLIANCE AFTER EACH USE:

1. Remove food from carving station.
2. Turn ON/OFF toggle switch to the "OFF" position. Disconnect unit from power source. Let the unit cool.
3. Remove cutting board after each use. Clean and sanitize separately following applicable state or local health sanitation ordinances. Air dry the board on a clean, flat surface to prevent board from warping. If the board becomes warped, heating will restore flexibility to facilitate flattening. Warped boards may be heated on the carving shelf surface, in a preheated Combitherm® CombiOven for 10 minutes on the steam program, or in a preheated Halo Heat Cook & Hold Oven for 15 minutes at 250°F (121°C).
4. Clean metal surfaces of the unit with a damp, clean cloth and any good commercial detergent at the recommended strength. Use a plastic scouring pad or oven cleaner for difficult areas. Rinse surfaces by wiping with sponge and clean warm water.



4. Surfaces can be wiped with a sanitizing solution after cleaning and rinsing. This solution must be approved for use on stainless steel food contact surfaces.
5. Clean breath guards with a window cleaner.
6. Do NOT use knives or utensils on the hot shelf surface. A cutting board is supplied.

Always follow appropriate state or local health (hygiene) regulations regarding all applicable cleaning and sanitation requirements for foodservice equipment.

<b>DANGER</b>	
	<b>AT NO TIME SHOULD THE INTERIOR OR EXTERIOR BE STEAM CLEANED, HOSED DOWN, OR FLOODED WITH WATER OR LIQUID SOLUTION OF ANY KIND. DO NOT USE WATER JET TO CLEAN.</b>
	<b>SEVERE DAMAGE OR ELECTRICAL HAZARD COULD RESULT.</b> <b>WARRANTY BECOMES VOID IF APPLIANCE IS FLOODED</b>

<b>DANGER</b>	
	<b>DISCONNECT UNIT FROM POWER SOURCE BEFORE CLEANING OR SERVICING.</b>

**NOTE:** Avoid the use of abrasive cleaning, compounds, chloride based cleaners, or cleaners containing quaternary salts. Never use hydrochloric acid (muriatic acid) on stainless steel.

# SANITATION

Food flavor and aroma are usually so closely related that it is difficult, if not impossible, to separate them. There is also an important, inseparable relationship between cleanliness and food flavor. Cleanliness, top operating efficiency, and appearance of equipment contribute considerably to savory, appetizing foods. Good equipment that is kept clean, works better and lasts longer.

Most food imparts its own particular aroma and many foods also absorb existing odors. Unfortunately, during this absorption there is not distinction between GOOD and BAD odors. The majority of objectionable flavors and odors troubling food service operations are caused by bacteria growth. Sourness, rancidity, mustiness, stale or other OFF flavors are usually the result of germ activity.

The easiest way to insure full, natural food flavor is through comprehensive cleanliness. This means good control of both visible soil (dirt) and invisible soil (germs). A thorough approach to sanitation will provide essential cleanliness. It will assure an attractive appearance of equipment, along with maximum efficiency and utility. More importantly, a good sanitation program provides one of the key elements in the prevention of food-borne illnesses.

A controlled holding environment for prepared foods is just one of the important factors involved in the prevention of food-borne illnesses. Temperature monitoring and control during receiving, storage, preparation, and the service of foods are of equal importance.

The most accurate method of measuring safe temperatures of both hot and cold foods is by internal product temperature. A quality thermometer is an effective tool for this purpose, and should be routinely used on all products that require holding at a specific temperature.

A comprehensive sanitation program should focus on the training of staff in basic sanitation procedures. This includes personal hygiene, proper handling of raw foods, cooking to a safe internal product temperature, and the routine monitoring of internal temperatures from receiving through service.

Most food-borne illnesses can be prevented through proper temperature control and a comprehensive program of sanitation. Both these factors are important to build quality service as the foundation of customer satisfaction. Safe food handling practices to prevent food-borne illness is of critical importance to the health and safety of your customers.

HACCP, an acronym for Hazard Analysis (at) Critical Control Points, is a quality control program of operating procedures to assure food integrity, quality, and safety. Taking steps necessary to augment food safety practices is both cost effective and relatively simple. While HACCP guidelines go far beyond the scope of this manual, additional information is available by contacting:

**CENTER FOR FOOD SAFETY AND APPLIED  
NUTRITION FOOD AND DRUG ADMINISTRATION  
1-888-SAFEFOOD**

INTERNAL FOOD PRODUCT TEMPERATURES		
<b>HOT FOODS</b>		
DANGER ZONE	40° TO 140°F	(4° TO 60°C)
CRITICAL ZONE	70° TO 120°F	(21° TO 49°C)
SAFE ZONE	140° TO 165°F	(60° TO 74°C)
<b>COLD FOODS</b>		
DANGER ZONE	ABOVE 40°F	(ABOVE 4°C)
SAFE ZONE	36° TO 40°F	(2° TO 4°C)
<b>FROZEN FOODS</b>		
DANGER ZONE	ABOVE 32°F	(ABOVE 0°C)
CRITICAL ZONE	0° TO 32°F	(-18° TO 0°C)
SAFE ZONE	0°F or below	(-18°C or below)

# SERVICE VIEW CS-100

201401

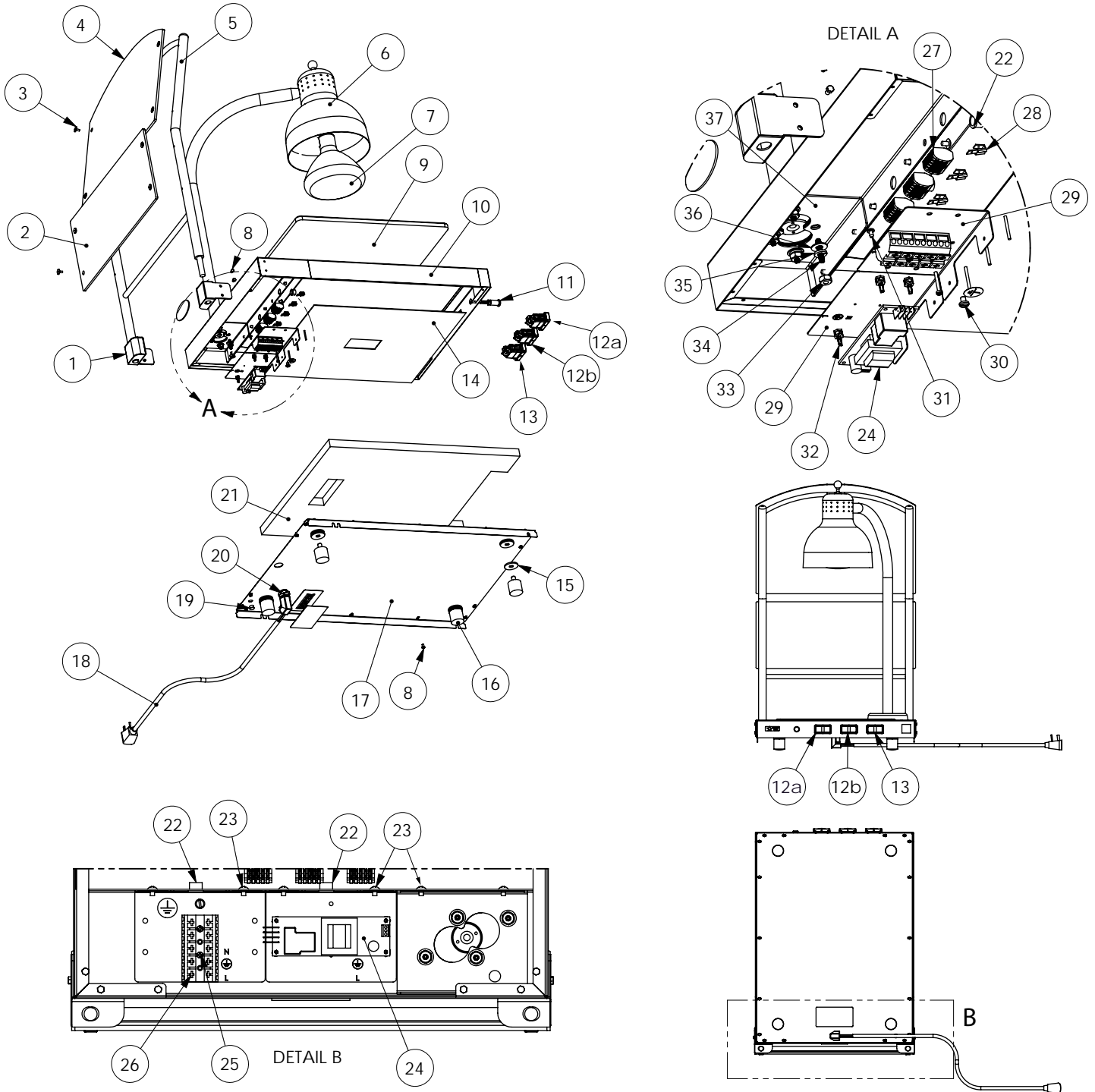

# SERVICE PARTS LIST CS-100

ITEM	DESCRIPTION	PART NO.	QTY
1	SNEEZE GUARD ATTACHMENT	1011870	2
2	TEMPERED GLASS, LOWER	GL-29241	1
3	SCREW, FLAT HEAD	SC-2816	8
4	TEMPERED GLASS, UPPER	GL-29240	1
5	BREATH GUARD FRAME	FR-28484	1
6	LAMP, HEATED SINGLE	LP-34896	1
7	LAMP, INFARED HEAT (250W, 120V)	LP-35721	1
	LAMP SOCKET ONLY, 120V	SK-35730	1
	LAMP, INFARED HEAT (250W, 230V)	LP-33781	1
	LAMP SOCKET ONLY, 230V	SK-35028	1
8	SCREW, HEX HEAD	SC-24751	22
9	CUTTING BOARD	BA-28482	1
10	TOP BASE PANEL	5008801	1
11	WHITE PILOT LIGHT (110V)	LI-3027	1
	WHITE PILOT LIGHT (250V)	LI-3951	1
12a	HEAT ON/OFF SWITCH, ROCKER	SW-34654	1
12b	HEAT LEVEL SWITCH, ROCKER, 3-WAY	SW-34653	1
13	LIGHT ON/OFF SWITCH, ROCKER	SW-34924	1
14	HEAT PAD (120V)	CB-34630	1
	HEAT PAD (230V)	CB-34544	1
15	WASHER	1010411	12
16	BUMPER FEET	BM-22606	4
17	BASE HOUSING COVER PANEL	5008802	1
18	CORDSET (125V)	CD-3232	1
	CORDSET (230V)	CD-3922	1
19	HOLE PLUG	PG-25574	1
20	BUSHING STRAIN RELIEF	BU-34898	1
21	INSULATION	IN-22265	1
22	BUSHING	BU-3006	2
23	SCREW, PHILLIPS HEAD	SC-2459	6
24	CONTROL BOARD (120V)	CC-34594	1
	CONTROL BOARD (230V)	CC-34657	1
25	SCREW, PHILLIPS PAN HEAD	SC-28846	2
26	CONNECTION BLOCK	BK-34711	1
27	CONNECTOR-5 CONDUCTOR	CR-34646	3
28	CONNECTOR, DUAL SPADE, 1/4"	CR-3849	6
29	L-BRACKET	1008529	2
30	PAN HEAD GROUND SCREW	SC-2190	1
31	PHILLIPS PAN SCREW	SC-28384	4
32	SPACER, NYLON SCREW	SP-28159	4
33	NUT, HEX HEAD	NU-2437	4
34	HEX HEAD SCREW	SC-29222	4
35	LOCK WASHER, 1/4"	WS-2294	4
36	FLAT WASHER	WS-22094	4
37	LAMP LOCK DOWN WASHER	1011278	1

# SERVICE VIEW CS-200

201301

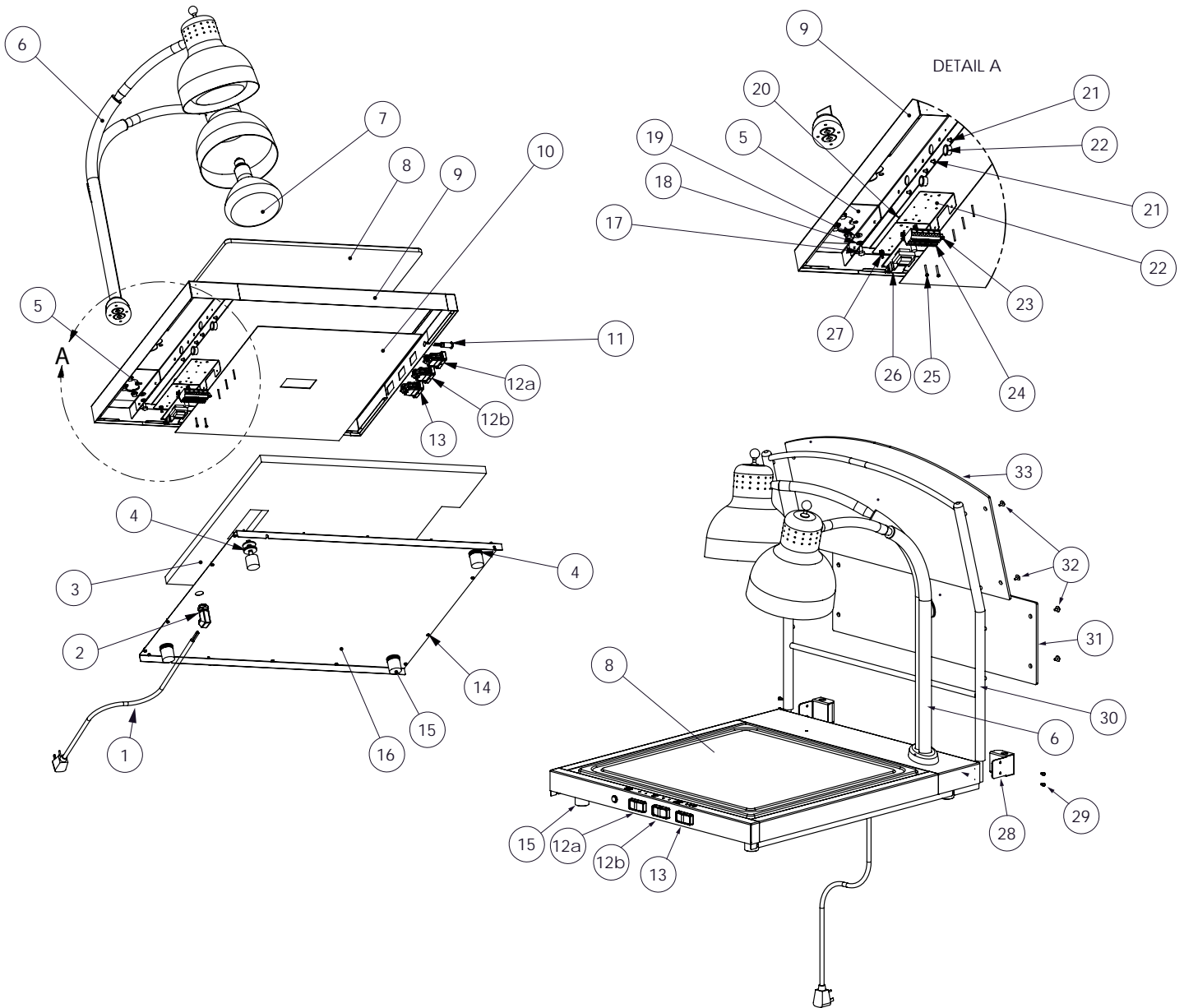



# SERVICE PARTS LIST CS-200

ITEM	DESCRIPTION	PART NO.	QTY
1	CORDSET (125V)	CD-3232	1
	CORDSET (230V)	CD-3922	1
2	BUSHING STRAIN RELIEF	BU-34898	1
3	INSULATION	IN-22265	1
4	WASHER	1010411	12
5	LAMP LOCK DOWN WASHER	1009413	1
6	LAMP, HEATED DUAL, FIXED (120V)	LP-34685	1
	LAMP, HEATED DUAL, FIXED (230V)	LP-34720	1
7	LAMP, INFARED HEAT (250W, 120V)	LP-35721	1
	LAMP SOCKET ONLY, 120V	SK-35730	1
	LAMP, INFARED HEAT (250W, 230V)	LP-33781	1
	LAMP SOCKET ONLY, 230V	SK-35028	1
	LAMP, INFARED HEAT, TEFLON COATED (MARINE, 230V)	LP-33781	2
8	CUTTING BOARD	BA-28066	1
9	TOP BASE PANEL	5007406	1
10	HEAT PAD	CB-34544	1
11	WHITE PILOT LIGHT (110V)	LI-3027	1
	WHITE PILOT LIGHT (250V)	LI-3951	1
12a	HEAT ON/OFF SWITCH, ROCKER	SW-34654	1
12b	HEAT LEVEL SWITCH, ROCKER, 3-WAY	SW-34653	1
13	LIGHT ON/OFF SWITCH, ROCKER	SW-34924	1
14	SCREW, HEX HEAD	SC-24751	18
15	BUMPER FEET	BM-22606	4
16	BASE HOUSING COVER PANEL	5007447	1
17	NUT, HEX HEAD	NU-2437	4
18	LOCK WASHER	WS-2294	4
19	FLAT WASHER	WS-22094	4
20	SCREW, PHILLIPS PAN HEAD	SC-28384	4
21	SCREW, PHILLIPS	SC-2459	6
22	BUSHING, SNAP	BU-3008	2
23	GROUND SCREW	SC-2190	1
24	CONNECTION BLOCK	BK-34711	1
25	SCREW, PHILLIPS PAN HEAD	SC-28846	2
26	CONTROL BOARD (120V)	CC-34594	1
	CONTROL BOARD (230V)	CC-34657	1
27	SPACER, NYLON SCREW	SP-28159	4
28	SNEEZE GUARD ATTACHMENT	1011870	2
29	SCREW, HEX HEAD	SC-24751	4
30	FRAME, BREATH GUARD	FR-28944	1
31	GLASS, TEMPERED, BOTTOM	GL-28604	1
32	SCREW, FLAT	SC-2816	8
33	GLASS, TEMPERED, TOP	GL-28416	1
34*	RELAY*	RL-33558	1

\* Not Shown

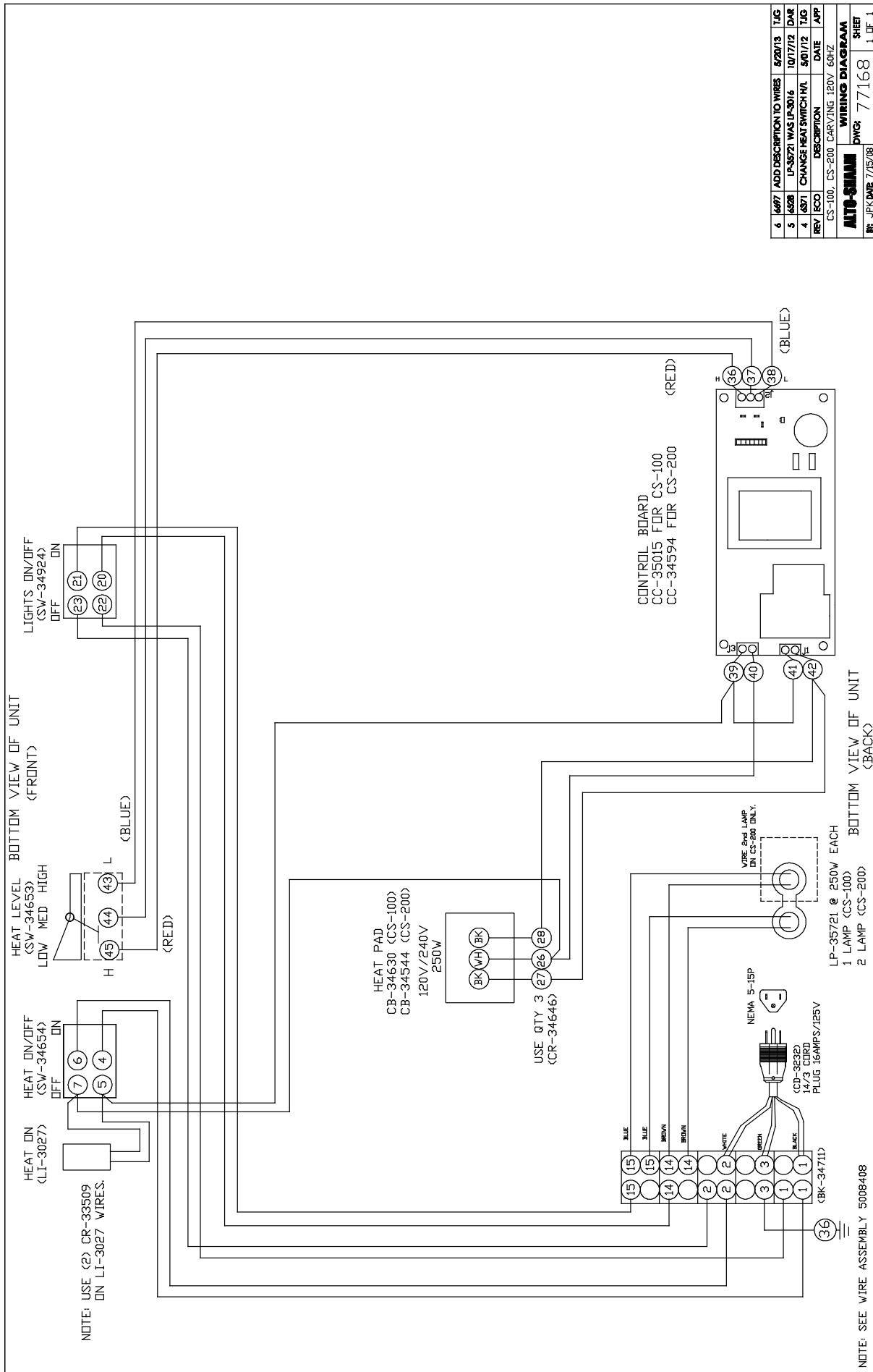

REV	ECO	DESCRIPTION	DATE	APP
6	4697	ADD DESCRIPTION TO WIRES	8/20/13	TJG
5	4528	LP-35721 WAS LP-3016	10/17/12	DAR
4	4371	CHANGE HEAT SWITCH H/L	5/01/12	TJG

WIRING DIAGRAM	
BR	JPK DATE
CS-100, CS-200	CARVING 120V 60HZ
PWG:	77168
SHEET	1 OF 1

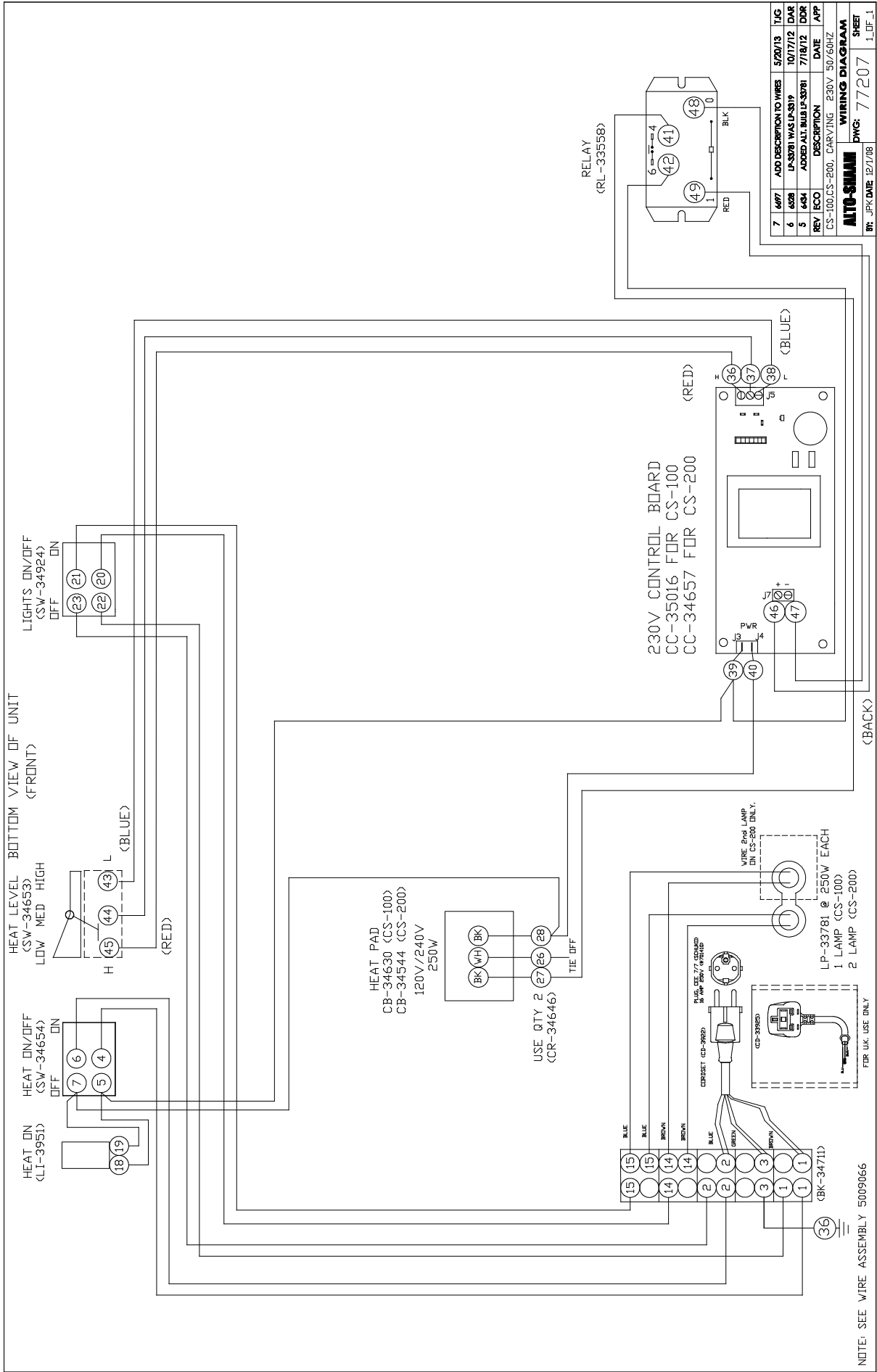

REV	ECO	DESCRIPTION	DATE	APP
7	4697	ADD DESCRIPTION TO WIRES	5/20/13	TJG
6	4698	IPAS3781 WAS IPAS319	10/17/12	DAR
5	4694	ADDED ALT BULB IPAS3781	7/18/12	DDR
4	4694	ADDED ALT BULB IPAS3781	7/18/12	DDR
3	4694	ADDED ALT BULB IPAS3781	7/18/12	DDR
2	4694	ADDED ALT BULB IPAS3781	7/18/12	DDR
1	4694	ADDED ALT BULB IPAS3781	7/18/12	DDR

CS-100/CS-200, CARRYING 230V 50/60HZ

**ALTO-SUMMIT** WIRING DIAGRAM

REV: JPK/DME 12/1/98 DWG: 77207

SHEET 1\_DF\_1

# TRANSPORTATION DAMAGE and CLAIMS



All Alto-Shaam equipment is sold F.O.B. shipping point, and when accepted by the carrier, such shipments become the property of the consignee.

Should damage occur in shipment, it is a matter between the carrier and the consignee. In such cases, the carrier is assumed to be responsible for the safe delivery of the merchandise, unless negligence can be established on the part of the shipper.

1. Make an immediate inspection while the equipment is still in the truck or immediately after it is moved to the receiving area. Do not wait until after the material is moved to a storage area.
2. Do not sign a delivery receipt or a freight bill until you have made a proper count and inspection of all merchandise received.
3. Note all damage to packages directly on the carrier's delivery receipt.
4. Make certain the driver signs this receipt. If he refuses to sign, make a notation of this refusal on the receipt.
5. If the driver refuses to allow inspection, write the following on the delivery receipt:  
*Driver refuses to allow inspection of containers for visible damage.*
6. Telephone the carrier's office immediately upon finding damage, and request an inspection. Mail a written confirmation of the time, date, and the person called.
7. Save any packages and packing material for further inspection by the carrier.
8. Promptly file a written claim with the carrier and attach copies of all supporting paperwork.

We will continue our policy of assisting our customers in collecting claims which have been properly filed and actively pursued. We cannot, however, file any damage claims for you, assume the responsibility of any claims, or accept deductions in payment for such claims.

## LIMITED WARRANTY

Alto-Shaam, Inc. warrants to the original purchaser only that any original part that is found to be defective in material or workmanship will, at Alto-Shaam's option, subject to provisions hereinafter stated, be replaced with a new or rebuilt part.

### The original parts warranty period is as follows:

For the refrigeration compressor on Alto-Shaam Quickchillers™, five (5) years from the date of installation of appliance.

For the heating element on Halo Heat® cooking and holding ovens, as long as the original purchaser owns the oven. This excludes holding only equipment.

For all other original parts, one (1) year from the date of installation of appliance or fifteen (15) months from the shipping date, whichever occurs first.

The labor warranty period is one (1) year from the date of installation or fifteen (15) months from the shipping date, whichever occurs first.

Alto-Shaam will bear normal labor charges performed during standard business hours, excluding overtime, holiday rates or any additional fees.

To be valid, a warranty claim must be asserted during the applicable warranty period. This warranty is not transferable.

### THIS WARRANTY DOES NOT APPLY TO:

1. Calibration.
2. Replacement of light bulbs, door gaskets, and/or the replacement of glass due to damage of any kind.
3. Equipment damage caused by accident, shipping, improper installation or alteration.
4. Equipment used under conditions of abuse, misuse, carelessness or abnormal conditions, including but not limited to, equipment subjected to harsh or inappropriate chemicals, including but not limited to, compounds containing chloride or quaternary salts, poor water quality, or equipment with missing or altered serial numbers.
5. Damage incurred as a direct result of poor water quality, inadequate maintenance of steam generators and/or surfaces affected by water quality. Water quality and required maintenance of steam generating equipment is the responsibility of the owner/operator.
6. Damage caused by use of any cleaning agent other than Alto-Shaam's Combitherm® Cleaner, including but not limited to damage due to chlorine or other harmful chemicals. **Use of Alto-Shaam's Combitherm® Cleaner on Combitherm® ovens is highly recommended.**
7. Any losses or damage resulting from malfunction, including loss of product, food product, revenue, or consequential or incidental damages of any kind.
8. Equipment modified in any manner from original model, substitution of parts other than factory authorized parts, removal of any parts including legs, or addition of any parts.

This warranty is exclusive and is in lieu of all other warranties, express or implied, including the implied warranties of merchantability and fitness for a particular purpose. In no event shall Alto-Shaam be liable for loss of use, loss of revenue or profit, or loss of product, or for any indirect, special, incidental, or consequential damages. No person except an officer of Alto-Shaam, Inc. is authorized to modify this warranty or to incur on behalf of Alto-Shaam any other obligation or liability in connection with Alto-Shaam equipment.



Effective November 1, 2012

RECORD THE MODEL AND SERIAL NUMBER OF THE APPLIANCE FOR EASY REFERENCE.

ALWAYS REFER TO BOTH MODEL AND SERIAL NUMBER IN ANY CONTACT WITH ALTO-SHAAM REGARDING THIS APPLIANCE.

Model: \_\_\_\_\_ Date Installed: \_\_\_\_\_  
Voltage: \_\_\_\_\_ Purchased From: \_\_\_\_\_  
Serial Number: \_\_\_\_\_

W164 N9221 Water Street • P.O. Box 450 • Menomonee Falls, Wisconsin 53052-0450 • U.S.A.  
PHONE: 262.251.3800 • 800.558-8744 USA/CANADA FAX: 262.251.7067 • 800.329.8744 U.S.A. ONLY

www.alto-shaam.com

PRINTED IN U.S.A.