

# FURUNO

## INSTALLATION MANUAL

MODEL 1724C MARINE RADAR  
MODEL 1734C MARINE RADAR  
GD-1720C COLOR VIDEO PLOTTER



 FURUNO ELECTRIC CO., LTD.

[www.furuno.co.jp](http://www.furuno.co.jp)

**ECF**

(Elemental Chlorine Free)

The paper used in this manual  
is elemental chlorine free.

© **FURUNO ELECTRIC CO., LTD.**

9-52 Ashihara-cho,  
Nishinomiya, 662-8580, JAPAN

Telephone : +81-(0)798-65-2111

Fax : +81-(0)798-65-4200

• FURUNO Authorized Distributor/Dealer

All rights reserved. Printed in Japan

Pub. No. IME-35550-D

(DAMI ) MODEL1704C\_GD-1720C

A : APR. 2005

D : SEP. 10, 2007



\* 0 0 0 1 5 1 8 0 9 1 3 \*



# SAFETY INSTRUCTIONS

## **WARNING**



Do not open the equipment unless totally familiar with electrical circuits and service manual.

**ELECTRICAL SHOCK HAZARD**

Only qualified personnel should work inside the equipment.



**Wear a safety belt and hard hat when working on the antenna unit.**

Serious injury or death can result if someone falls from the radar mast.

**Construct a suitable service platform from which to install the antenna unit.**

Serious injury or death can result if someone falls from the radar mast.

**Turn off the power at the mains switch-board before beginning the installation.**

Fire, electrical shock or serious injury can result if the power is left on or is applied while the equipment is being installed.

## **CAUTION**



**Ground the equipment to prevent electrical shock and mutual interference.**

**Observe the following compass safe distances to prevent deviation of a magnetic compass.**

	Standard	Steering
Display unit	0.55 m	0.35 m
1724C antenna	1.30 m	0.80 m
1734C antenna	1.41 m	1.10 m

## **WARNING**

### **Radio Frequency Radiation Hazard**

The radar antenna emits electromagnetic radio frequency (RF) energy which can be harmful, particularly to your eyes. Never look directly into the antenna aperture from a close distance while the radar is in operation or expose yourself to the transmitting antenna at a close distance.

Distances at which RF radiation levels of 100 and 10 W/m<sup>2</sup> exist are given in the table below.

**Note:** If the antenna unit is installed at a close distance in front of the wheel house, your administration may require halt of transmission within a certain sector of antenna revolution. This is possible - Ask your FURUNO representative or dealer to provide this feature.

MODEL	Distance to 100 W/m <sup>2</sup> point	Distance to 10 W/m <sup>2</sup> point
1724C	Nil	Worst case 1.50 m
1734C	0.40	Worst case 4.00 m

# TABLE OF CONTENTS

---

<b>EQUIPMENT LISTS .....</b>	<b>iii</b>
<b>SYSTEM CONFIGURATIONS.....</b>	<b>v</b>
<b>1. MOUNTING .....</b>	<b>1</b>
1.1 Installation of Display Unit.....	1
1.2 Mounting of Antenna Units.....	4
<b>2. WIRING .....</b>	<b>16</b>
2.1 Standard Wiring .....	16
2.2 External Buzzer (OP03-136, option) Connection .....	19
2.3 How to Connect with a PC.....	20
<b>3.SETTING UP THE EQUIPMENT .....</b>	<b>21</b>
3.1 Setting up with the Installation Wizard.....	21
3.2 Checking Magnetron Heater Voltage.....	33
3.3 Remote Controller Setting.....	34
<b>PACKING LISTS .....</b>	<b>A-1</b>
<b>OUTLINE DRAWINGS .....</b>	<b>D-1</b>
<b>INTERCONNECTION DIAGRAMS .....</b>	<b>S-1</b>

# EQUIPMENT LISTS

## Standard supply

Name	Type	Code No.	Qty	Remarks	
Display unit	RDP-148	-	1		
Antenna unit	RSB-110-070-A	-	1	For MODEL1724C	
	RSB-0071-058	-	1	For MODEL 1734C	
Remote controller set	RMC-100	000-089-885	1	Remote controller, vinyl case, battery, labels	
Installation materials	CP03-22200	000-089-887	1	For display unit	
	CP03-22100	000-089-848	1	For MODEL 1724C antenna unit, 5 m signal cable S03-87-5	
	CP03-22110	000-089-849		For MODEL 1724C antenna unit, 10 m signal cable S03-87-10	
	CP03-22120	000-089-850		For MODEL 1724C antenna unit, 15 m signal cable SO3-87-15	
	CP03-22130	000-089-851		For MODEL 1724C antenna unit, 20 m signal cable SO3-87-20	
	CP03-22140	000-089-852		For MODEL 1724C antenna unit, 30 m signal cable S03-87-30	
	CP03-22300	000-089-888		1	For MODEL 1734C antenna unit, 10 m signal cable S03-88-10
	CP03-22310	000-089-889	For MODEL 1734C antenna unit, 15 m signal cable SO3-88-15		
	CP03-22320	000-089-900	For MODEL 1734C antenna unit, 20 m signal cable S03-88-20		
	CP03-22330	000-089-914	For MODEL 1734C antenna unit, 30 m signal cable S03-88-30		
		CP03-20301	008-440-670	1	For antenna unit of MODEL 1724C
		CP03-18001	008-478-740	1	For antenna unit of MODEL 1734C
	Spare parts	SP03-15201	008-547-740	1	

## Optional supply

Name	Type	Code No.	Qty	Remarks
Rectifier	PR-62	000-013-484	1	For 100 VAC
		000-013-485		For 110 VAC
		000-013-486		For 220 VAC
		000-013-487		For 230 VAC
External buzzer	OP03-136	000-086-443	1	
Cable assy.	MJ-A6SPF0014-010C	000-154-027-10	1	For NavNet, 1 m
	MJ-A6SPF0014-050C	000-154-049-10	1	For NavNet, 5 m
	MJ-A6SPF0014-100C	000-154-050-10	1	For NavNet, 10 m
	MJ-A6SPF0014-200C	000-154-051-10	1	For NavNet, 20 m
	MJ-A6SPF0014-300C	000-154-052-10	1	For NavNet, 30 m
	MJ-A6SPF0012-050C	000-154-053-10	1	For navaid, 5 m
	MJ-A6SPF0012-100C	000-154-037-10	1	For navaid, 10 m
	MJ-A6SPF0003-050C	000-154-054-10	1	w/6P connector, 5 m
	MJ-A6SPF0009-100C	000-154-036-10	1	w/6P connector, 10 m
	MJ-A6SPF0007-100C	000-159-695-10	1	For compass, 10 m
	MJ-A7SPF0007-050C	000-154-02810	1	For external buzzer/PC, w/7P connector, 5 m
	MJ-A6SRMD/TM11AP8-005	000-144-463	1	Adapter cable for HUB
Remote controller set	RMC-100	000-089-885	1	Remote controller, vinyl case, battery, labels
Mounting bracket (1)	OP03-92	008-445-070	1	For MODEL1734C antenna unit
Mounting bracket (2)	OP03-93	008-445-080	1	For MODEL1724C antenna unit
AIS Interface	IF-1500AIS			For connection of FA-100

# SYSTEM CONFIGURATIONS

All NavNet products incorporate a “network circuit board” to integrate each NavNet product on board through an optional LAN cable (Ethernet 10BASE-T). Each NavNet product is assigned an IP address to enable transfer of images between other NavNet products. For example, video plotter pictures can be transferred to a radar and vice versa. Pictures received via the NavNet may be adjusted at the receiving end.

The number of display units which may be installed depends on the number of network sounder connected. For a system incorporating three or more products, a “hub” is required to process data.

For one network sounder: one radar and three plotters

For two network sounder: one radar and two plotters

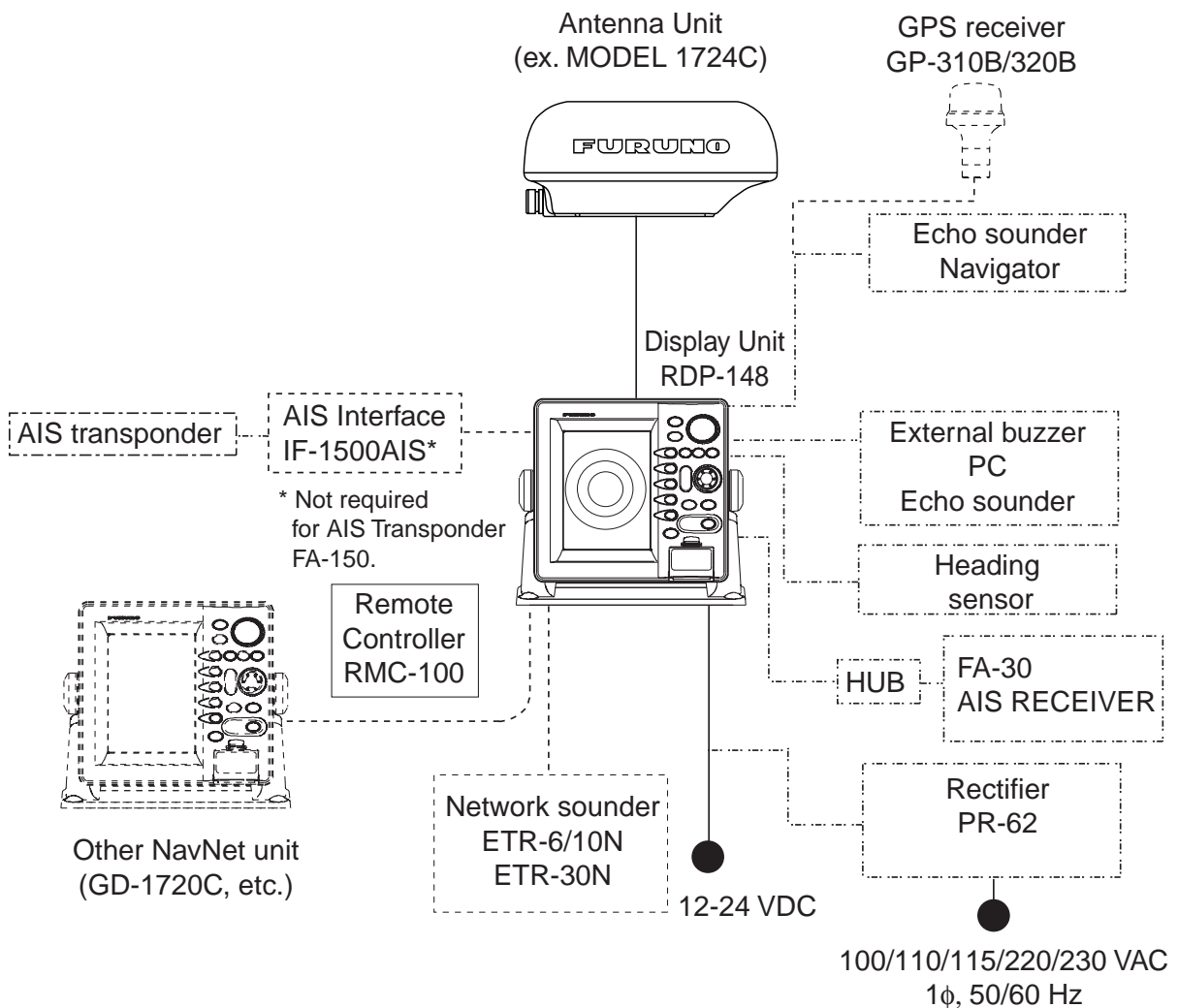

*NavNet2 system MODEL 1724C/MODEL 1734C*

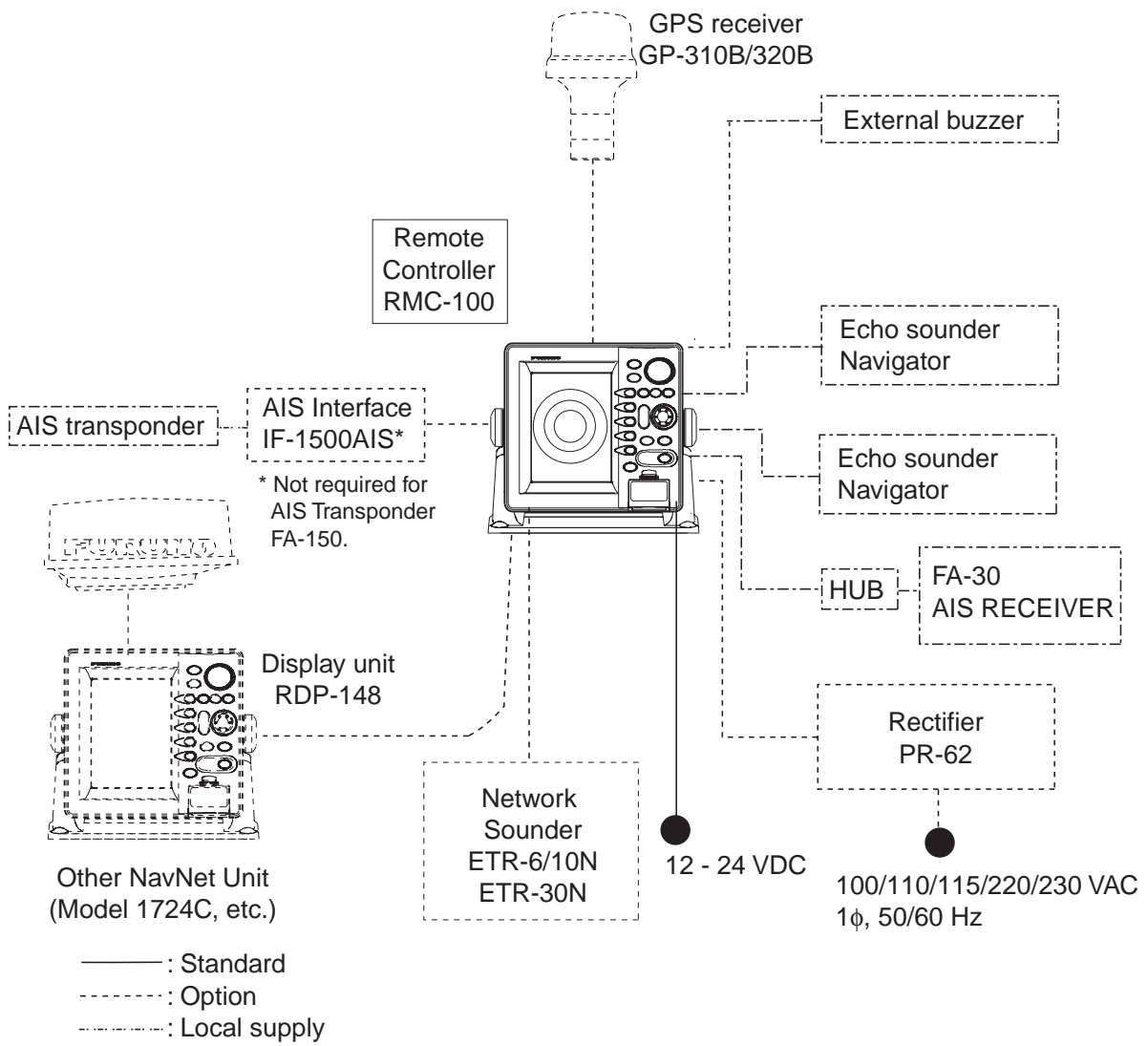

Navnet2 system GD-1720C



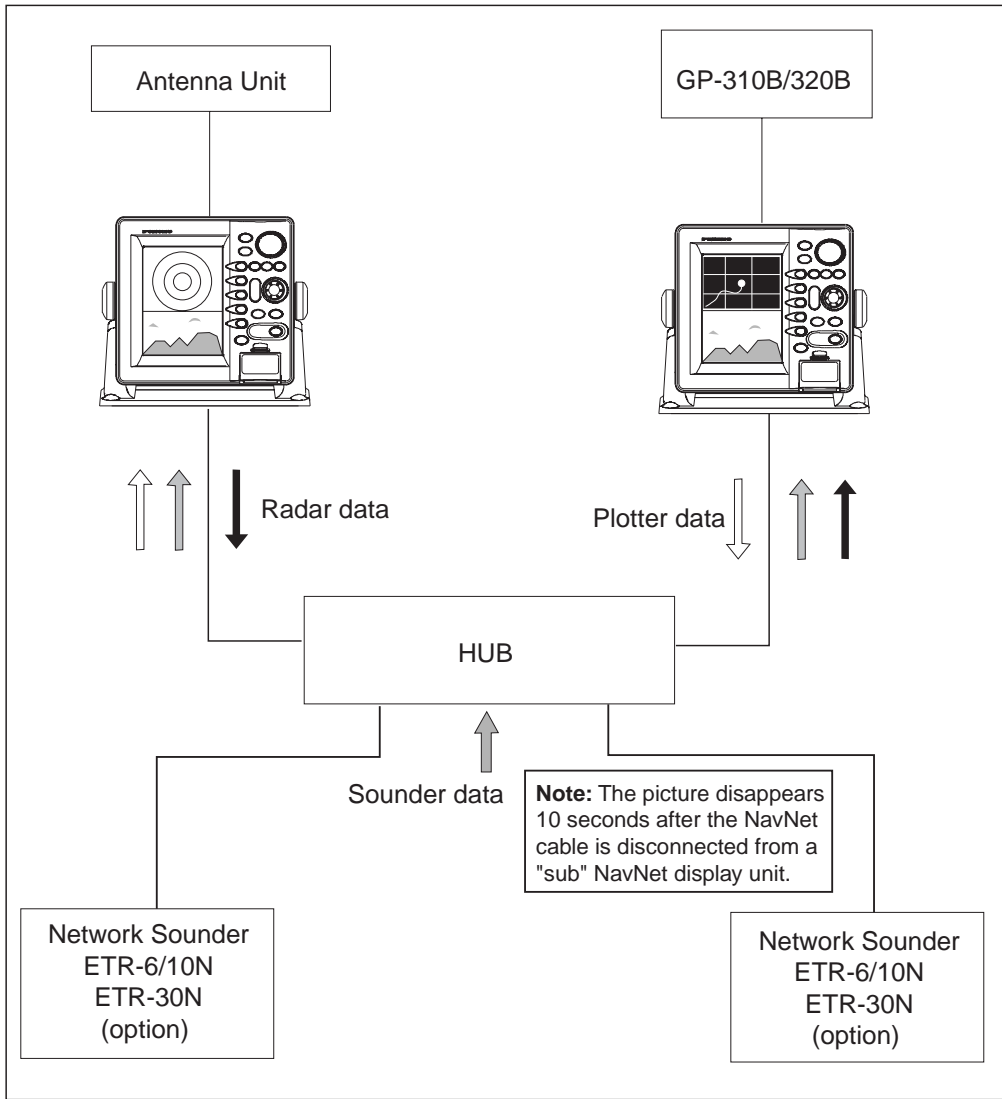

Figure 2 (a) NavNet2 system, three-unit connection

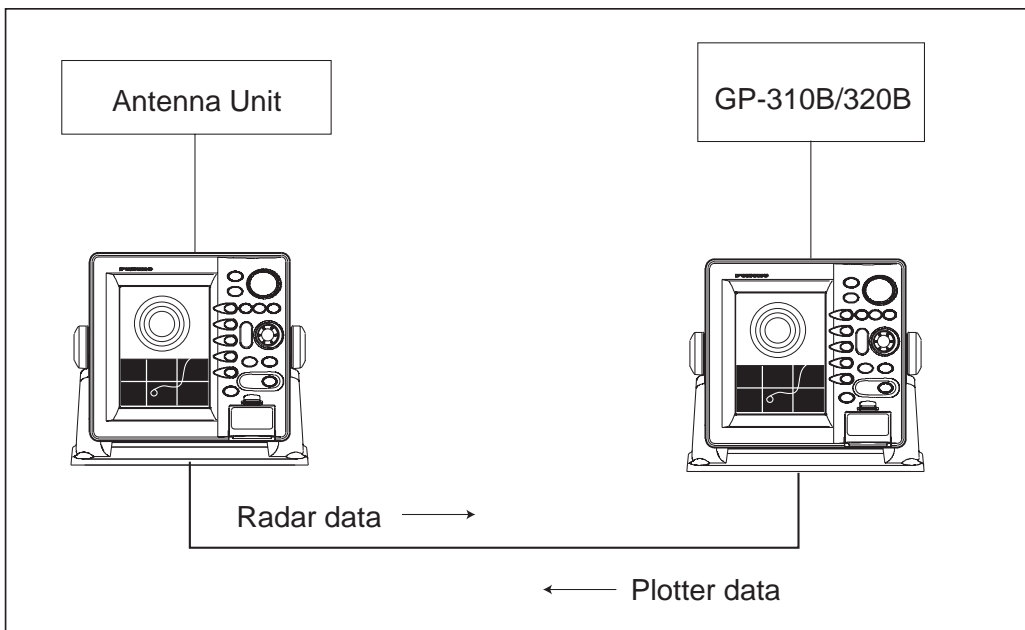

Figure 2 (b) NavNet2 system, two-unit connection

*This page is intentionally left blank.*

# 1. MOUNTING

---

## NOTICE

**Do not apply paint, anti-corrosive sealant or contact spray to coating or plastic parts of the equipment.**

Those items contain organic solvents that can damage coating and plastic parts, especially plastic connectors.

## 1.1 Installation of Display Unit

The display unit can be installed on a tabletop, on the overhead or flush mounted in a console or panel.

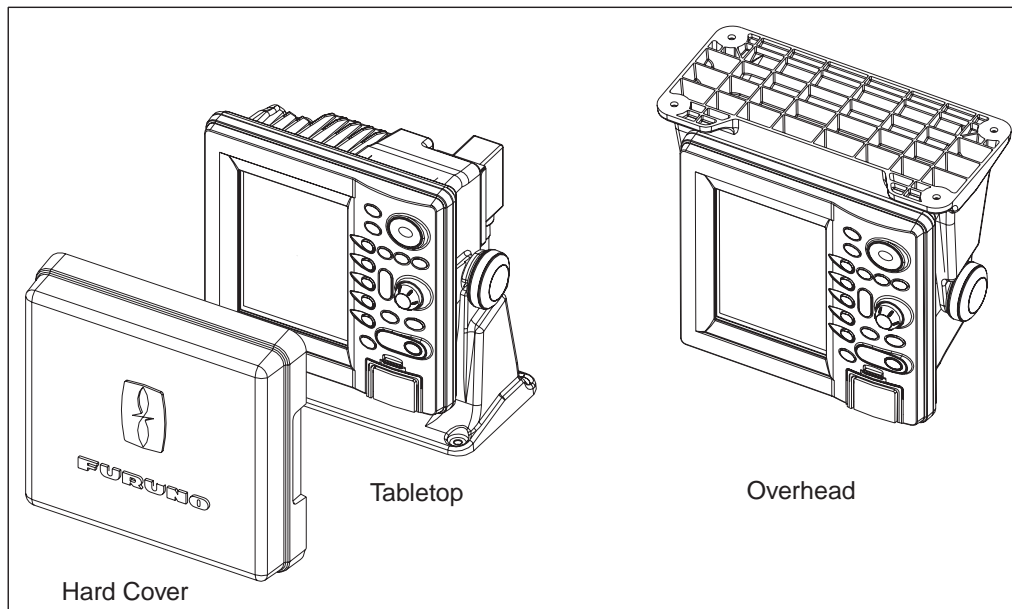

*Tabletop, overhead mounting method*

When selecting a mounting location for the display unit keep the following in mind:

- Keep the display unit out of direct sunlight.
- The temperature and humidity should be moderate and stable.
- Locate the unit away from exhaust pipes and vents.
- The mounting location should be well ventilated.
- Mount the unit where shock and vibration are minimal.
- Keep the unit away electromagnetic field generating equipment such as motor, generator.
- For maintenance and checking purposes, leave sufficient space at the sides and rear of the unit and leave slack in cables.
- A magnetic compass will be affected if the display unit is placed too close to the magnetic compass. Observe the compass safe distances show in the Safety Instructions to prevent disturbance to a magnetic compass.

## 1.1.1 Mounting procedure

### Tabletop, overhead mounting

Follow the procedure below to mount the display unit on a tabletop or the overhead.

1. Fix the hanger by four tapping screw.
2. Screw knob bolts in display unit, set it to hanger, and tighten knob bolts.
3. Attach hard cover to protect LCD.

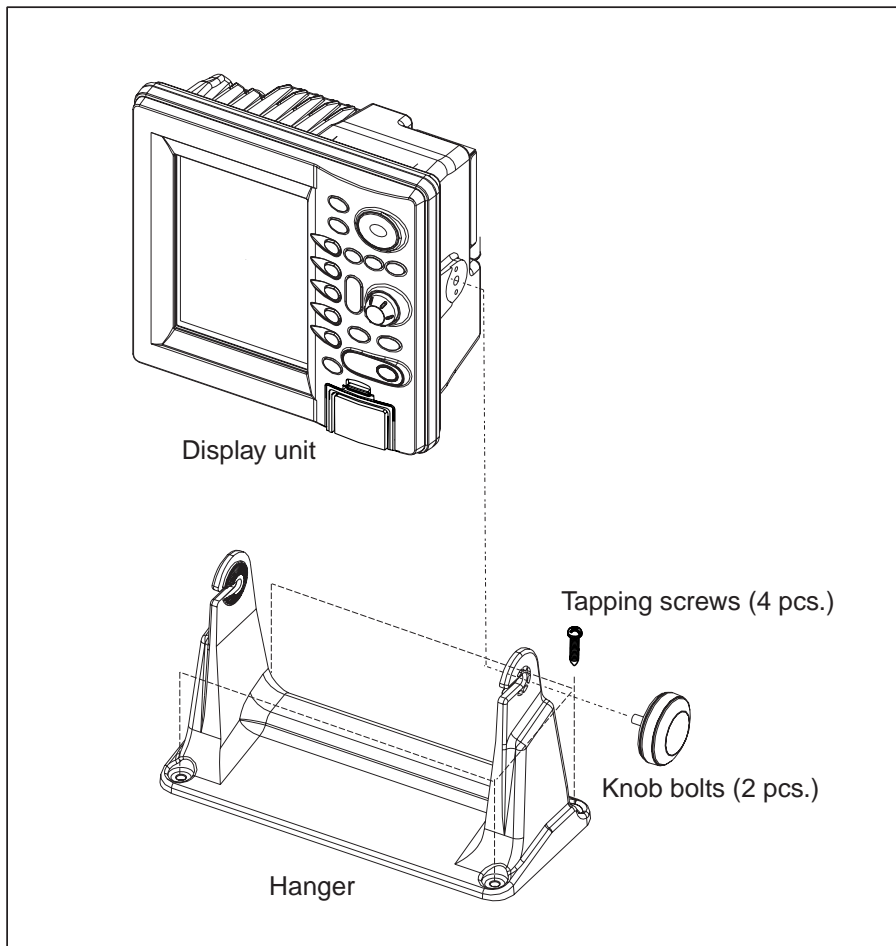

*Tabletop, overhead mounting of display unit*

## Flush mounting

**Note:** Use supplied pan head screws when the thickness of the bulkhead is from 11 to 14 mm. For bulkhead which exceeds 14 mm in thickness the length of the pan head screws should be bulkhead thickness (A) plus  $7.3 \pm 1.5$  mm. Also the length of B should be max. 7 mm.

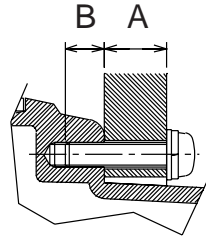

*Fixing screw, side view*

1. Prepare a cutout in the mounting location whose dimensions are as shown in below.
2. Attach the flush mount sponge to the display unit.
3. Fix the display unit by six washer head screws M4x20. Refer to the outline drawing at back of this manual.

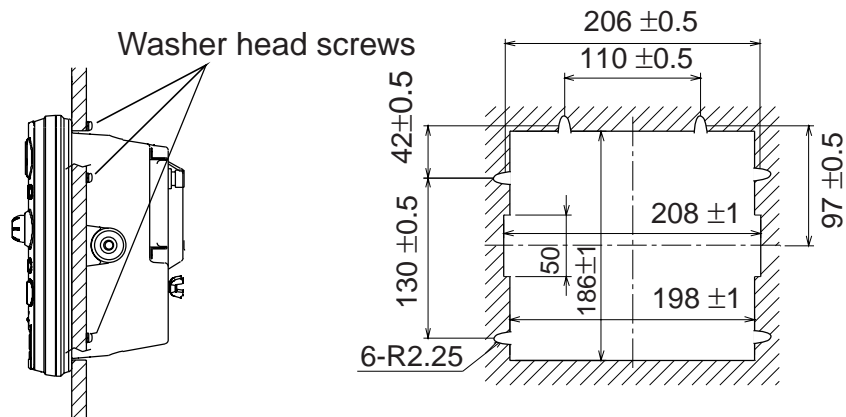

*Flush mounting of display unit*

## 1.2 Mounting of Antenna Units

### 1.2.1 Mounting considerations

When selecting a mounting location for the antenna unit keep in mind the following points.

- Install the antenna unit on the hardtop, radar arch or on a mast on an appropriate platform. (For sailboats, a mounting bracket is optionally available.) It should be placed where there is a good all-round view with, as far as possible, no part of the ship's superstructure or rigging intercepting the scanning beam. Any obstruction will cause shadow and blind sectors. A mast, for instance, with a diameter considerably less than the width of the antenna unit, will cause only a small blind sector. However, a horizontal spreader or crosstrees in the same horizontal plane would be a much more serious obstruction; place the antenna unit well above or below it.

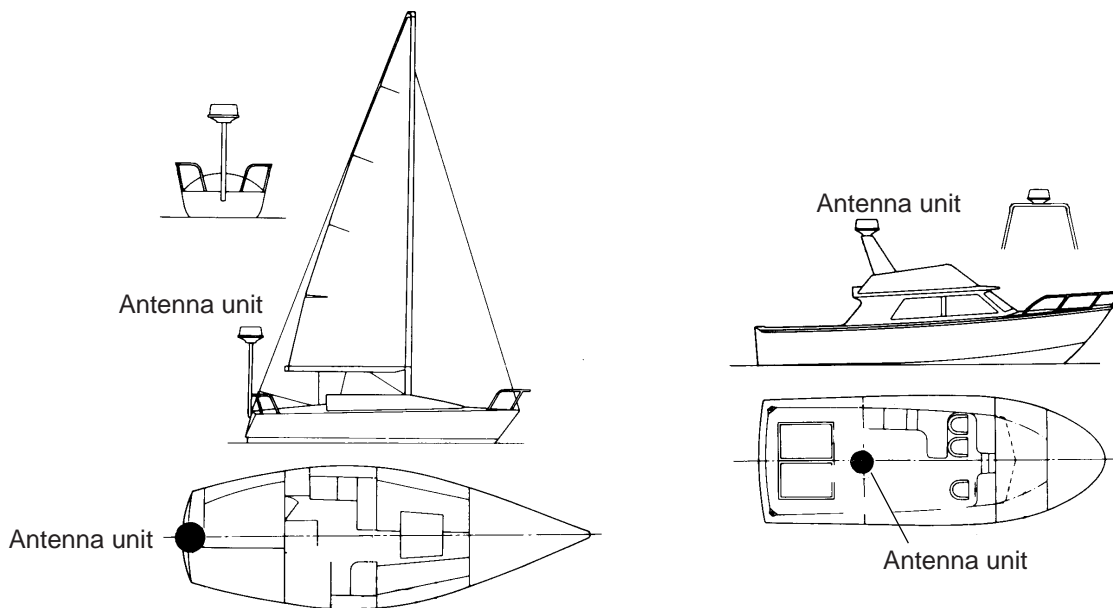

*Typical antenna unit placement on sailboat and powerboat*

- In order to minimize the chance of picking up electrical interference, avoid where possible routing the antenna cable near other electrical equipment onboard. Also avoid running the cable in parallel with power cables.
- Observe the safe compass distances shown in the Safety Instructions to prevent interference to a magnetic compass.

## 1.2.2 Mounting antenna unit of MODEL 1724C

1. Remove mounting hardware at the bottom of the antenna unit; four each of hex bolts (M10X20), spring washers and flat washers. Save the spring washers and flat washers to use them to fix the radome base to the platform, at step 3. If the thickness of the mounting platform is 5 mm or less also save the bolts.

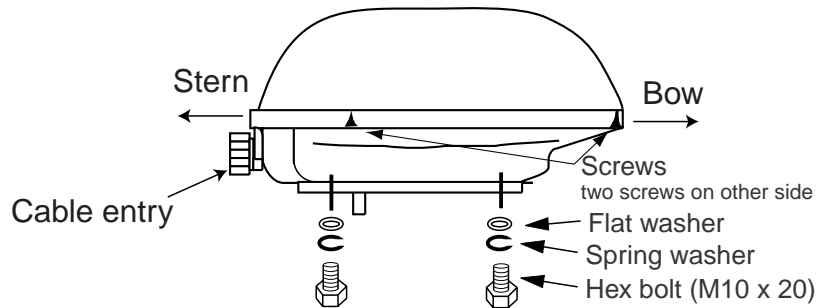

*Antenna unit, showing location of mounting hardware*

2. Construct a platform (wood, steel, or aluminum) 6-10 mm in thickness referring to the outline drawing at the back of this manual. (A mounting bracket for mounting the antenna unit on a sailboat mast is optionally available. Refer to page 14.) Fasten the platform to the mounting location. Next, position the base so the cable entrance faces the stern direction.

**Note:** When drilling holes in the platform, be sure they are parallel with the fore and aft line.

3. Using the hex bolts\*, flat washers and spring washers removed at step 1, fasten the radome base to the platform. **The torque should be between 19.6-24.5 N•m.**

\* If the thickness of the platform is 6-10 mm, use M10x25 bolts (supplied). For thicker platform use locally supplied bolts.

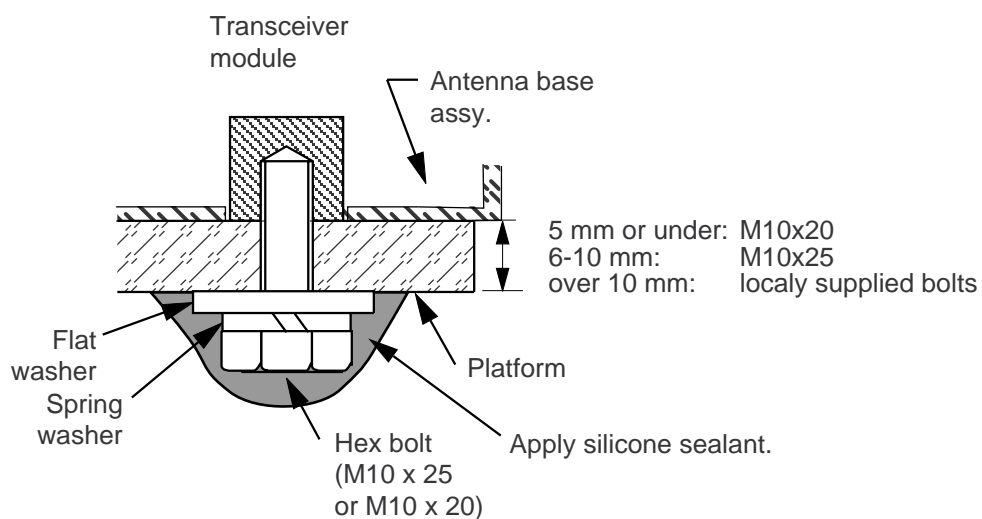

*How to fasten the radome base to platform*

4. Unfasten four screws to remove the cover. Discard the packing material in the radome.

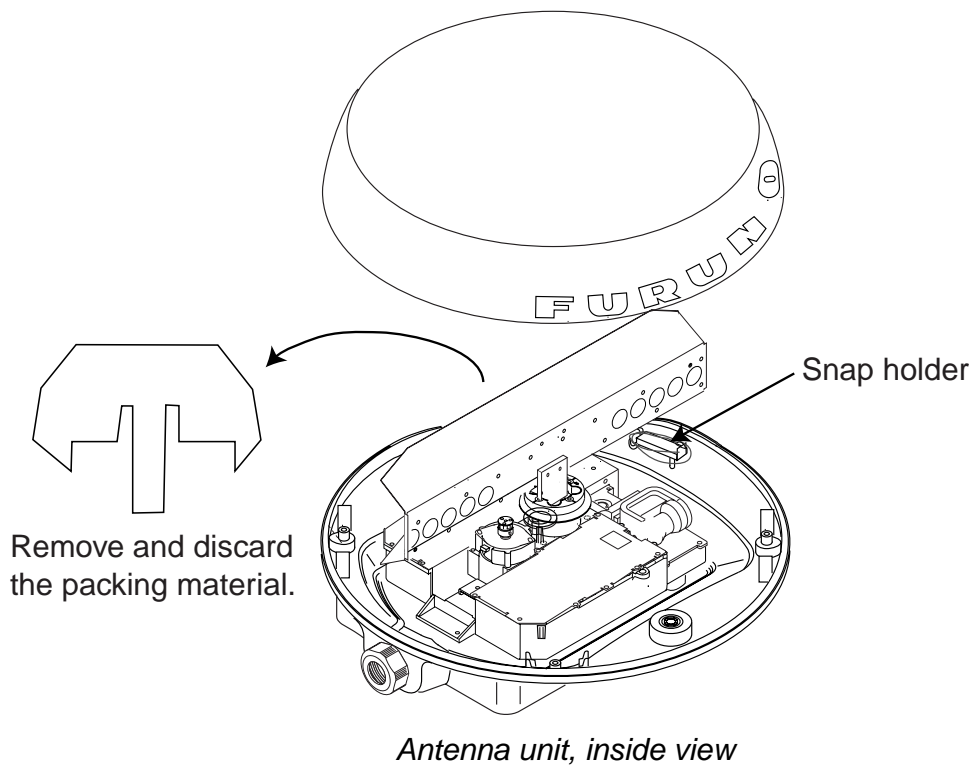

The mounting base is fitted with a snap holder, which may be used to hang the cover after removal. Use the hole next to screw hole inside the cover to hang it.

- a) Unfasten the snap assy. with the string attached at the holder in the mounting base.
- b) Unwind the string.
- c) Attach the snap to a screw hole on the inside of the cover.

**Note:** Do not hang any other objects with the snap.



5. Unfasten the cable of the rotation detector from the cable clamps.
6. Unfasten 11 screws to dismount the shield plate. Discard screw marked with ↓ in the figure shown below.

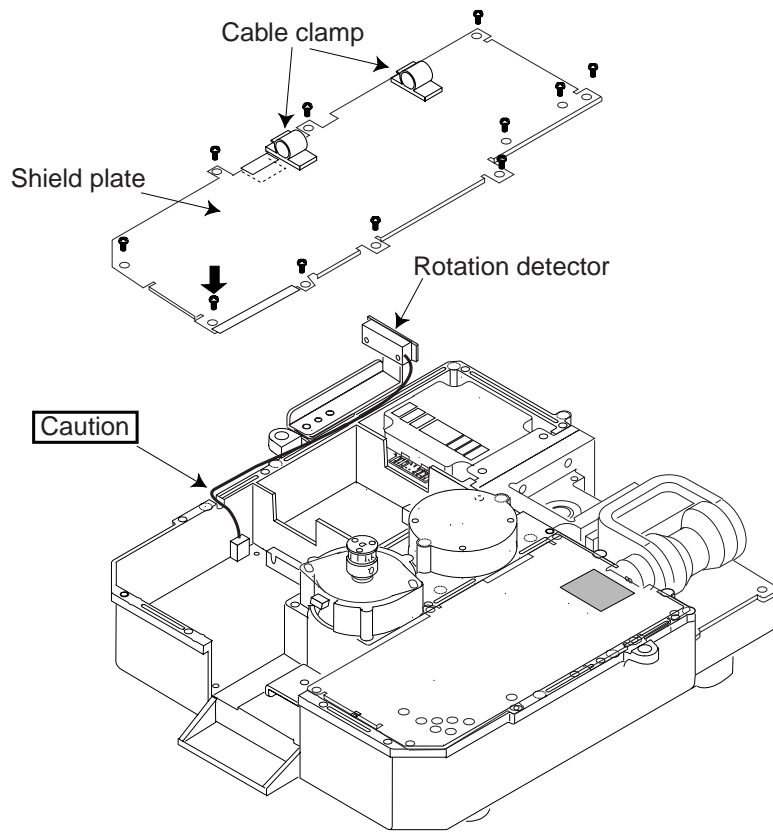

*Antenna unit, inside view*

**Caution:** Be careful not to pinch the rotation detector cable when remounting the shield plate.

7. Pass the antenna cable with connector through the gasket and cable clamp, and then tighten cable gland.  
Be sure the shrink tubing on the antenna cable is not covered by the gasket.

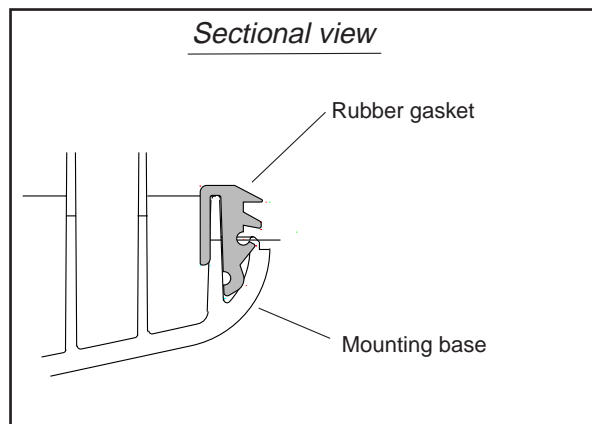
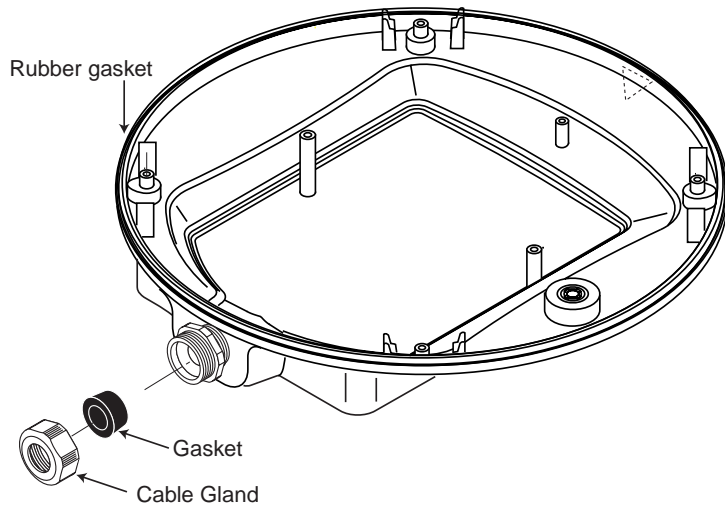

*Antenna unit, inside view*

- Referring to the figure shown below, fasten the shield cable with screw (M4x10) on the chassis to ground the unit.

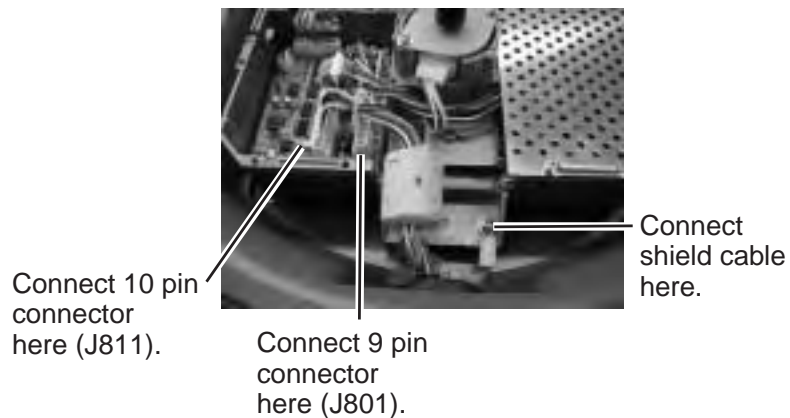

*How to connect the antenna cable to the antenna unit*

- Attach EMI core (supplied) to antenna cable between cable ties. Set the fixing band to the EMI core.

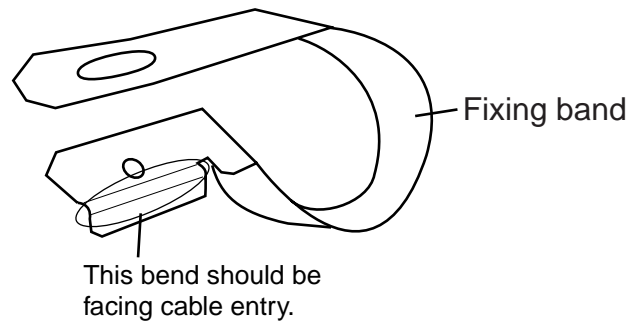

*Fixing band*

- Referring to the figure of "How to connect the antenna cable to the antenna Unit" on the previous page connect the 9-pin (J801) and 10-pin (J811) connectors of the antenna cable to the INT Board.
- Refasten the shield plate with 10 screws. Be sure not to pinch cable from the rotation detector with the shield plate. See "Caution" in the figure of "Antenna unit, inside view" on page 7, for details.
- Fasten the fixing band with screw (M4X15; supplied).

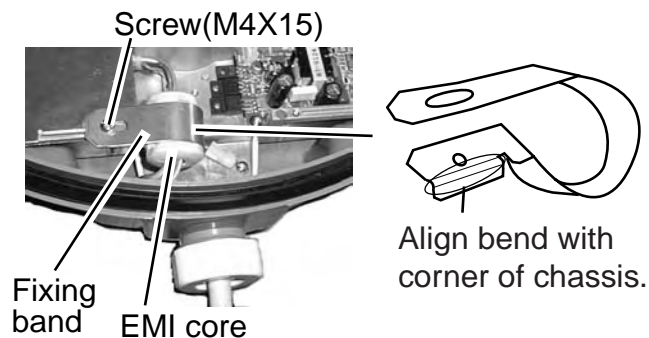

*How to fix the EMI core*

- Follow the instructions on the label inside the mounting base to secure the snap assy.
- Confirm that the rubber gasket is properly positioned and that the triangle mark on the radome cover is aligned with the triangle mark on the mounting base, then tighten the fixing screws for the cover. Refer to the figure of sectional view on the previous page for positioning of rubber gasket.

### 1.2.3 Mounting antenna unit of MODEL 1734C

1. Open the antenna unit packing box carefully.
2. Unbolt the four bolts at the base of the radome to remove the radome cover.

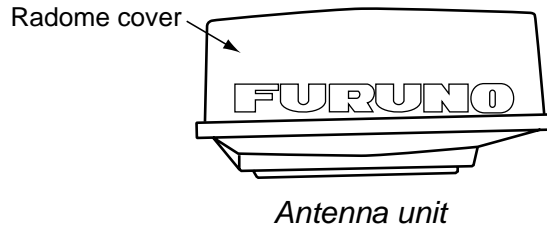

The mounting surface must be parallel with the waterline and provided with five holes (four fixing holes and one cable entry) whose dimensions are shown in the outline drawing attached at the end of this manual.

The unit is adjusted so a target echo returned from the bow direction will be shown on the zero degree (heading line) position on the screen. When drilling holes, be sure they are parallel with the fore and aft line.

3. Prepare a platform of 5 to 10 millimeters in thickness for the antenna unit. A mounting bracket for mounting the antenna unit on a sailboat mast is optionally available. (Refer to page 14.) Find the cable entry on the radome base. Next, position the radome base so the cable entry faces the stern direction. This alignment must be as accurate as possible.

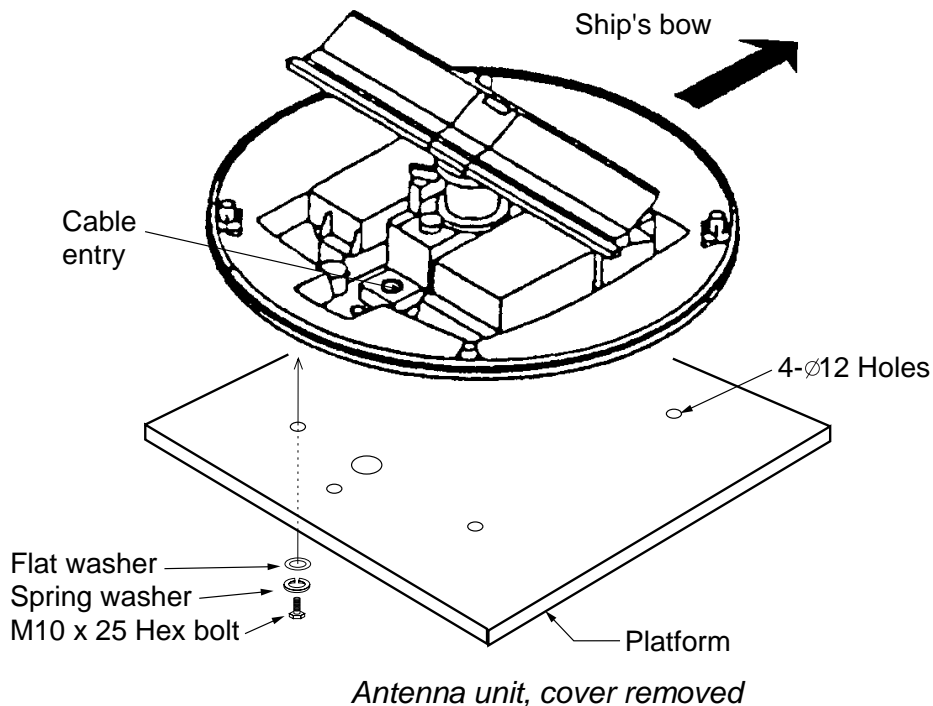

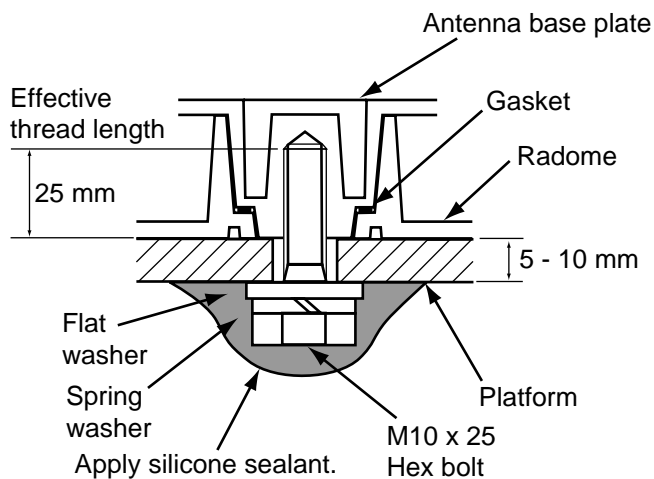

*How to fasten the radome base to the mounting platform*

### **Wiring and final preparation**

4. Drill a hole of at least 20 millimeters diameter through the deck or bulkhead to run the signal cable between the antenna unit and the display unit. (To prevent electrical interference avoid running the signal cable near other electrical equipment and in parallel with power cables.) Pass the cable through the hole. Then, seal the hole with sealing compound for waterproofing.
5. Remove two shield covers in the radome.
6. Remove the cable clamping plate by unfastening four screws and removing a gasket.

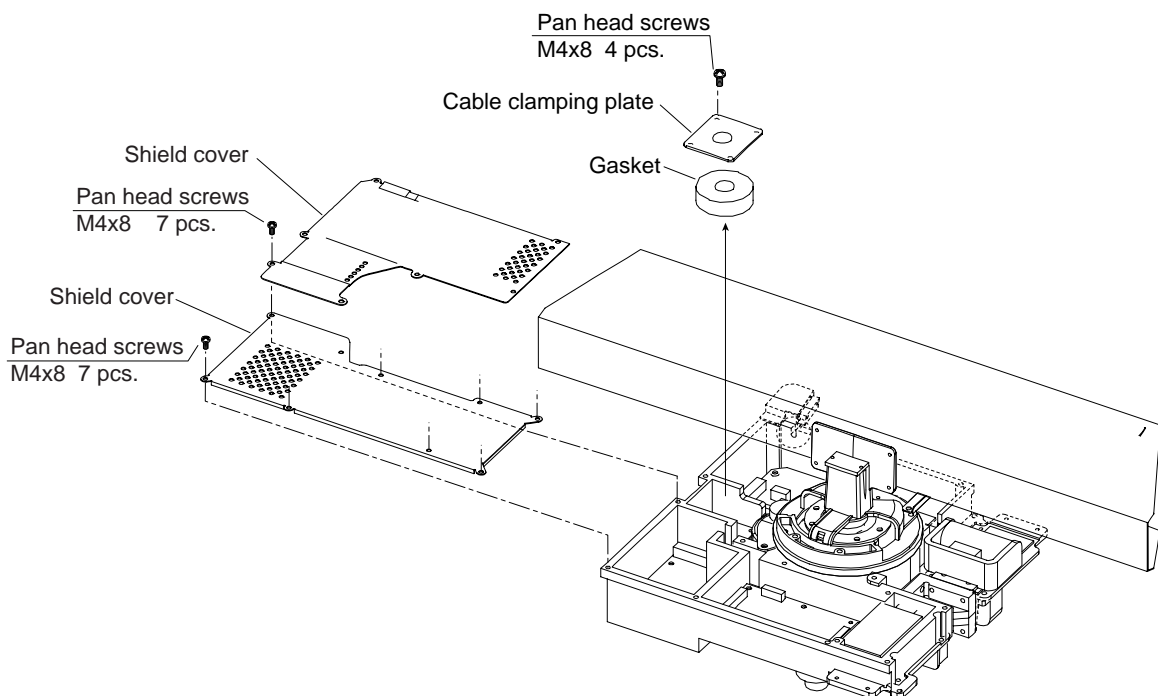

*Antenna unit, inside view*

7. Pass the cable through the hole at the bottom of the radome base.
8. Secure the cable with the cable clamping plate and gasket. Ground the shield wire by one of the screws of the cable clamping plate.
9. Attach three connectors of the signal cable to respective ports as shown below.

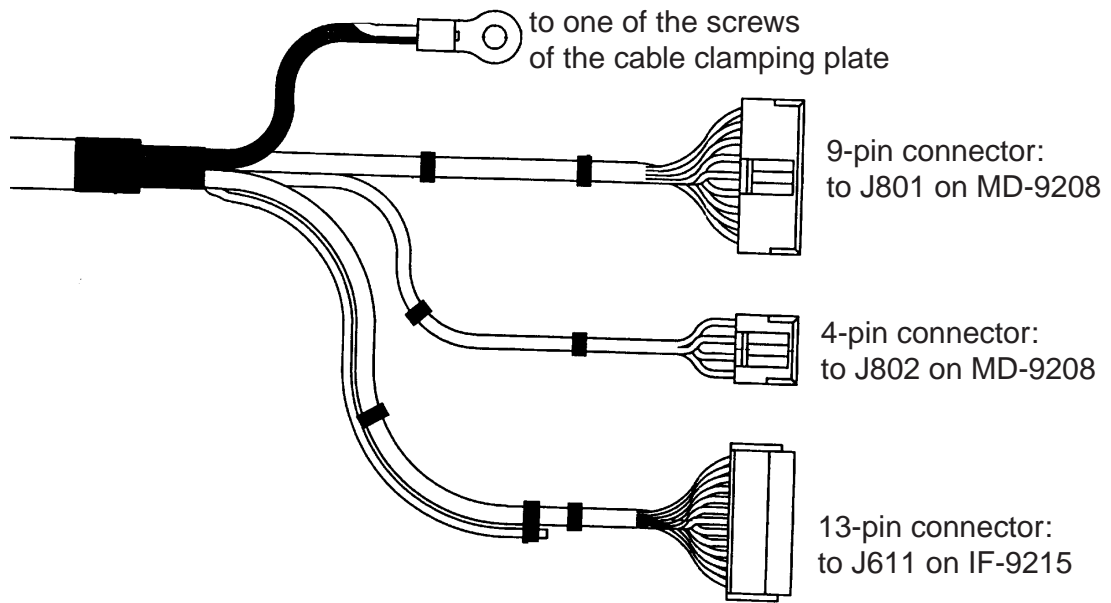

*Signal cable, antenna unit side*

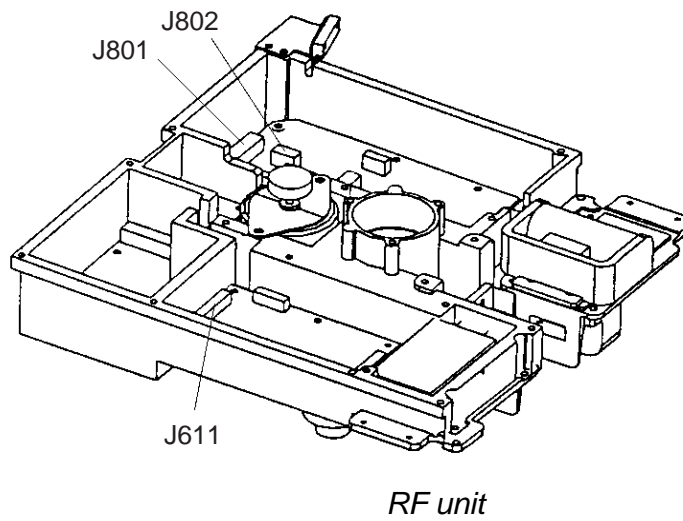

10. Attach the EMC core supplied as shown below.

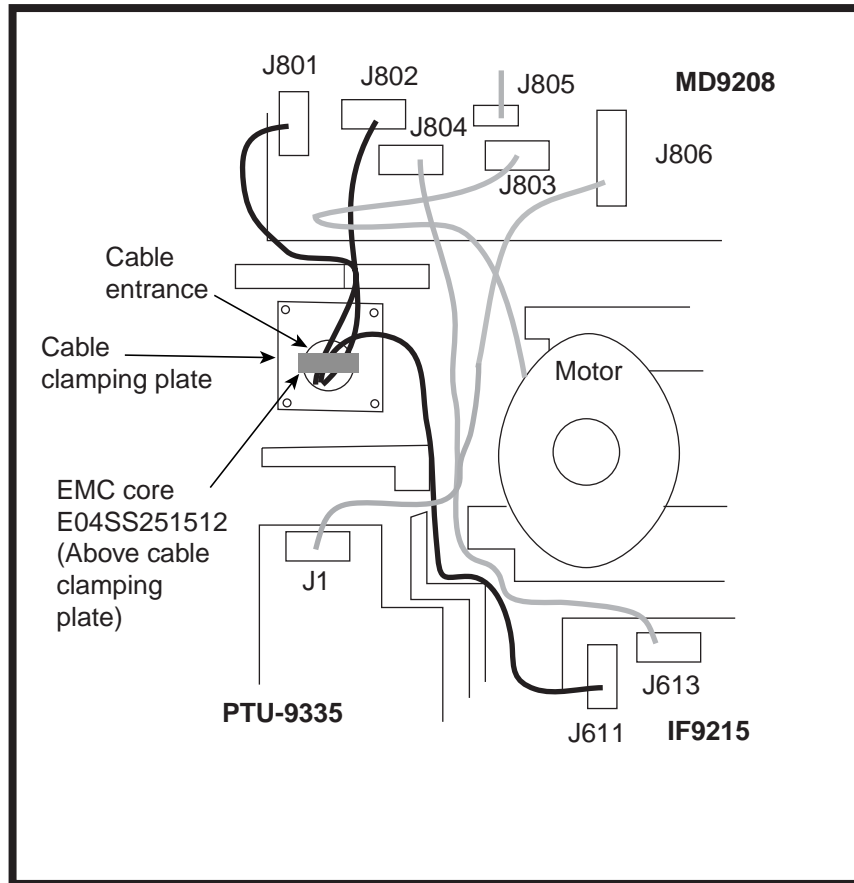

*How to attach EMC core*

11. Fix the shield cover. Do not pinch the cable.
12. Attach the radome cover, aligning triangle mark on radome cover with that on radome base.

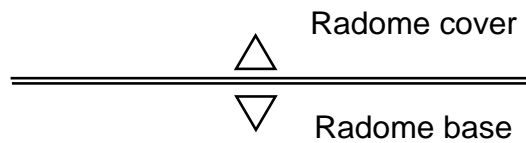

*How to position the radome cover*

13. Loosely fasten the radome fixing bolts. You will tighten them after confirming magnetron heater voltage.

## 1.2.4 Mounting the optional mounting bracket

A mounting bracket for fastening the antenna unit to a mast on a sailboat is optionally available.

### **Mounting bracket 1 (for MODEL 1734C)**

Type: OP03-92

Code No.: 008-445-070

Part	Type	Code No.	Qty
Hex. bolt	M4X12	000-804-725	4
Hex. bolt	M8X20	000-805-707	8
Mounting plate	03-018-9001-0	100-206-740	1
Support plate (1)	03-018-9005-0	100-206-780	1
Support plate (2)	03-018-9006-0	100-206-790	1
Bracket (1)	03-018-9002-1	100-206-751	1
Bracket (2)	03-018-9003-1	100-206-761	1
Fixing plate	03-018-9004-1	100-206-771	2

### **Mounting bracket 2 (for MODEL 1724C)**

Type: OP03-93

Code No.: 008-445-080

Part	Type	Code No.	Qty
Hex. bolt	M4X12	000-804-725	4
Hex. bolt	M8X20	000-805-707	8
Mounting plate	03-018-9001-0	100-206-740	1
Support plate (1)	03-018-9005-0	100-206-780	1
Support plate (2)	03-018-9006-0	100-206-790	1
Bracket (1)	03-028-9101-0	100-206-810	1
Bracket (2)	03-028-9102-0	100-206-820	1
Fixing plate	03-028-9103-0	100-206-830	2

Assemble the mounting bracket and fasten it to a mast. Fasten the antenna unit to the bracket.



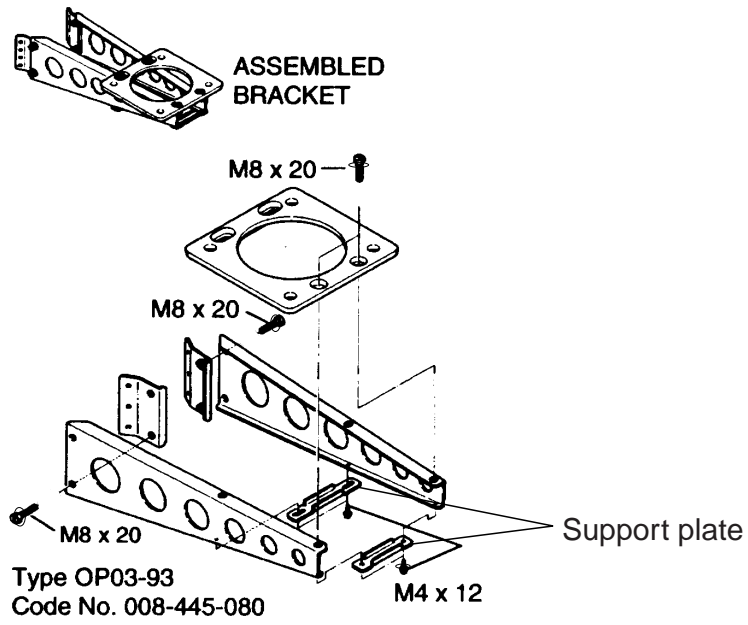

**(A) Assembling the mounting bracket**

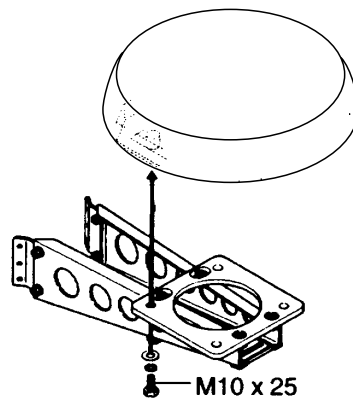

**(B) Fastening antenna to mounting bracket**

*How to assemble and mount the optional mounting bracket*

# 2. WIRING

## 2.1 Standard Wiring

All wirings are terminated at the rear of the display unit.

**⚠ CAUTION**

The power cable is shipped with a 10A fuse (5A on GD-1720C) inserted in its fuse holder. This fuse is for use with a 12 VDC power supply. If you are using a 24 VDC power supply, replace the fuse with a 5A fuse (3A fuse on GD-1720C). Also, attach the "5A label" ("3A label" on GD-1720C) to the fuse holder on the power cable. Use of an improper fuse can result in damage to the equipment.

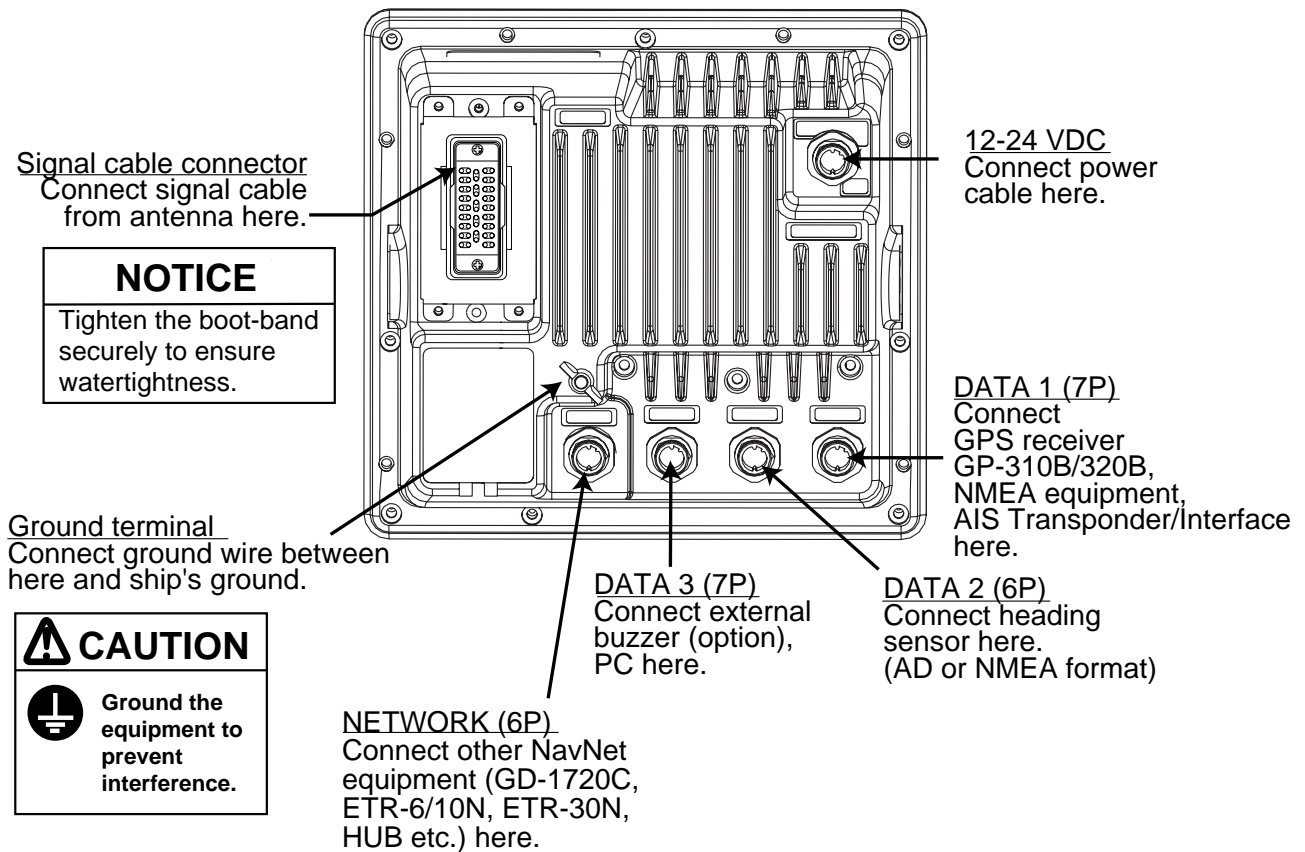

*Display unit, rear view*

For signal cable connection, see the procedure on the next page.

## Signal cable connection

1. Remove the waterproofing cover from the DJ-1 at the back of the display unit.
2. Connect the signal cable to DJ-1 on the rear panel of the display unit.

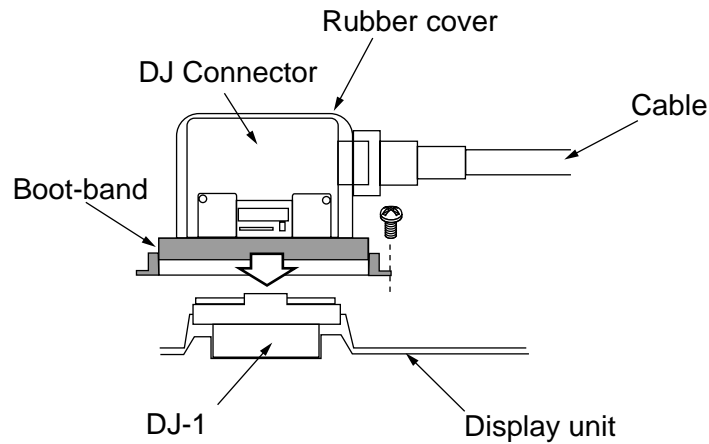

3. Cover the connector with the rubber cover.
4. Put the boot-band as shown above, and fasten four screws to fix.

**Note:** When the display unit is used without signal cable connection, do not remove the waterproofing cover. Wrap the display unit and waterproofing cover with vinyl tape.

## Power cable

Connect the power cable to the power connector.

## Ground terminal

Connect the ground wire (local supply, IV-2sq) between the ground terminal and ship's ground.

## DATA1 to DATA3 ports

Other equipments can be connected here as shown below.

DATA1 (7P)	DATA2 (6P)	DATA3 (7P)
GPS receiver GP-310B/320B, NMEA equipments	Heading sensor (ex. SC-60/120)	NMEA IN, NMEA OUT for PC External buzzer

This equipment can receive the following NMEA 0183 format sentence from other equipments.

- Own ship's position: GGA>RMC>RMA>GLL
- Ship's speed: RMC>RMA>VTG>VHW
- Destination waypoint: RMB
- Heading (True): HDT>HDG>HDM
- Course: RMC>RMA>VTG
- Depth: DPT>DBT
- Temperature: MTW
- Time: ZDA
- Other ship's information: TTM
- Insight satellite information: GSV
- Wind speed and angle: MWV>VWT>VWR

## NETWORK port

Other NavNet equipment should be connected to this port with the optional NavNet cable. Available equipment are shown below.

Radar	Plotter	Network sounder	Other
MODEL1724C/1734C	GD-1720C	ETR-6/10 ETR-30N	HUB (used when more than two NavNet units are connected.)

## 2.2 External Buzzer (OP03-136, option) Connection

The optional external buzzer provides a louder alert when the guard alarm is violated.

External buzzer

Type: OP03-136

Code no.: 000-086-443

Further, you need the optional cable assy MJ-A7SPF0007-050C (w/7P connector, 5 m, code no. 000-154-028-10).

1. Attach the MJ-A7SPF0007-050C cable assy (option) to the DATA 3 port at the rear of the display unit.
2. Cut the XH connector at the end of external buzzer cable with appropriate length.
3. Solder the cables made at step 2 with MJ-A7SPF0007-050C cable as shown below.

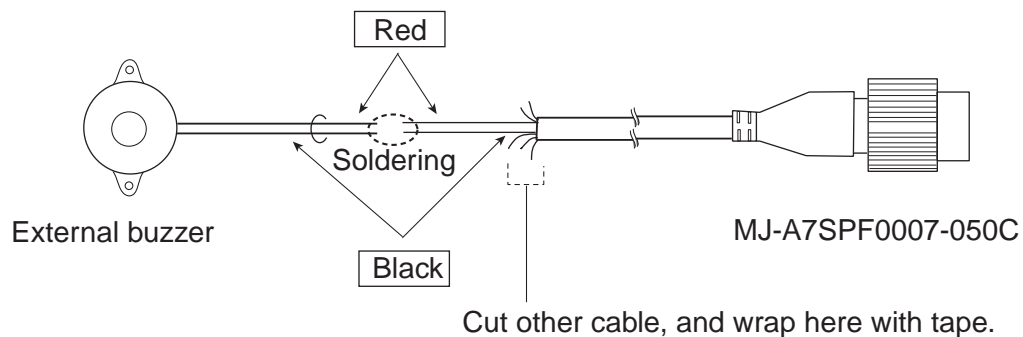

*Connection of external buzzer and display unit  
using cable assy type MJ-A7SPF0007-050C cable*

4. Fasten the buzzer with the double-sided tape or two tapping screws (3x15 or 3x20, local supply).

## 2.3 How to Connect with a PC

When connecting with the personal computer, prepare the optional cable assy MJ-A7SPF0007-050C and D-sub 9 pins plug (local supply), and connected them as follows. This function is not available with the GD-1720C.

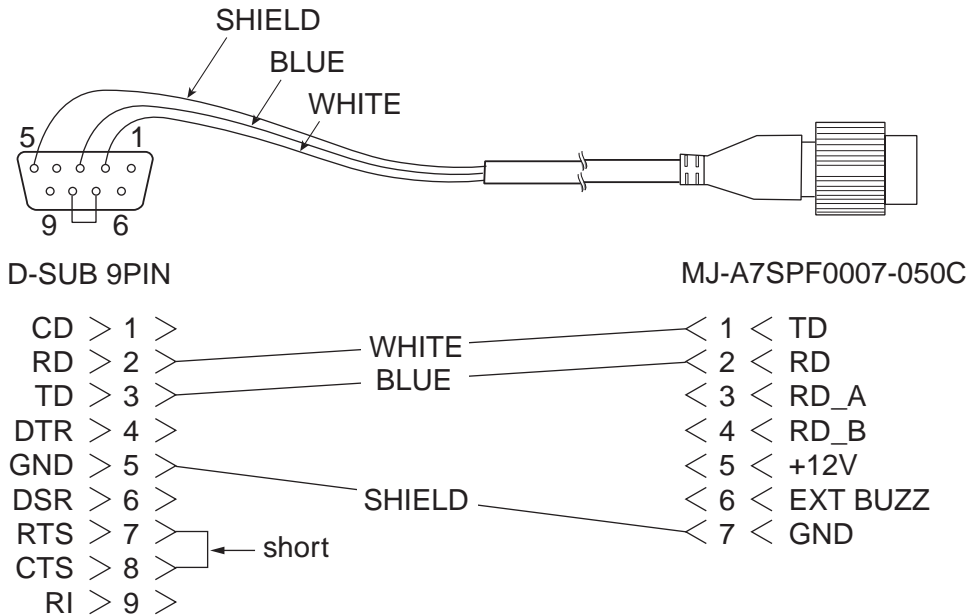

*MJ-A7SPF0007-050C cable connection for PC*

# 3. SETTING UP THE EQUIPMENT

## 3.1 Setting up with the Installation Wizard

After you have installed the equipment, set up the equipment with the installation wizard. The wizard allows you to easily set up the NavNet network (choose source of radar, sounder and auxiliary), GPS, ports, etc.

1. Press the **POWER/BRILL** key to turn on the power, and the following screen appears.

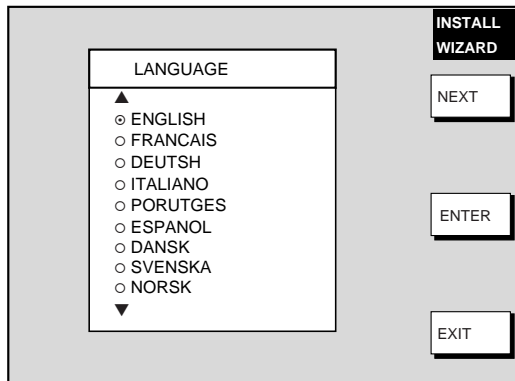

*Installation wizard, language selection window*

2. Rotate the **ENTER** knob to choose the appropriate language and then push the ENTER soft key.
3. A dialog box asks you if you want to start the simulation mode, which provides simulated operation of the equipment.
4. Press the **CLEAR** key to skip the simulation mode. Then, the SELECT MODE window appears.

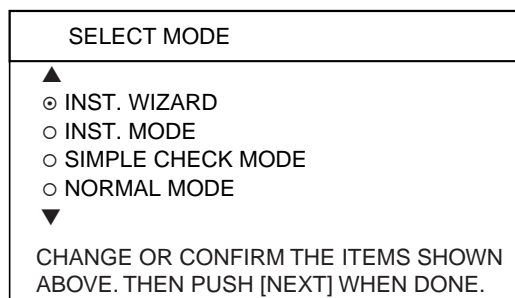

5. Confirm that INST. WIZARD is selected, and then push the ENTER soft key. A diagnostic test is conducted and then the chart disclaimer message appears.
6. You are then asked "LOAD SETTING DATA FROM CARD?". This allows you to use the set up this NavNet unit with the settings of another NavNet unit, thereby shortening the time required to set up the equipment. To use the settings of another NavNet unit, insert the appropriate SD card in the slot and push the **ENTER** knob. If not, hit the **CLEAR** key. If you loaded settings, the message "LOADING COMPLETED. REMOVE THE CARD AND PRESS ANY KEY TO RESTART" appears if loading was successful. Remove the card and press any key to restart the equipment; installation is completed. To set up manually, go to step 7.

**CAUTION:** Ensure that the settings to be loaded are compatible with this NavNet unit. Improper settings will damage the equipment.

- The screen for set up of units of measurement appears.

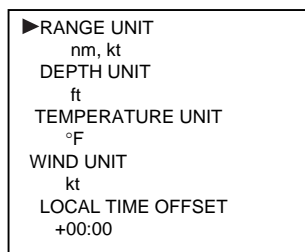

*Installation wizard, units of measurement*

- Choose an item and then press the EDIT soft key. One of the following windows appears.

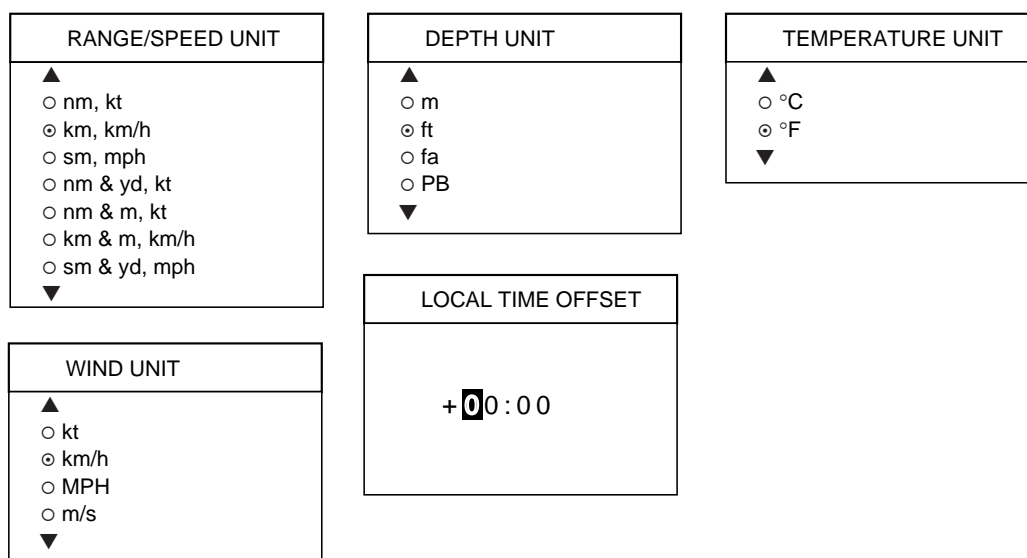

- Choose unit of measurement desired and then press the ENTER soft key. LOCAL TIME OFFSET allows you to use local time (instead of UTC time). Set the time difference between local time and UTC time.
- After you have chosen units of measurement, press the NEXT soft key, and the NETWORK SETUP menu appears. This is where you set up your NavNet network. See the illustration on then next page for typical network setup. **If you have no other NavNet devices installed, press the NEXT key and go to step 13.**

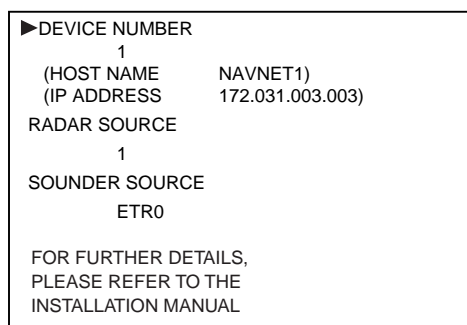

*Installation wizard, network setup*



11. Choose DEVICE NUMBER, RADAR SOURCE or SOUNDER SOURCE as appropriate and then press the EDIT soft key. One of the following displays appears depending on your selection.

DEVICE NUMBER
▲
○ 1 (IP:172.031.003.001)
○ 2 (IP:172.031.003.002)
○ 3 (IP:172.031.003.003)
○ 4 (IP:172.031.003.004)
▼

RADAR SOURCE
▲
○ 1 (IP:172.031.003.001)
○ 2 (IP:172.031.003.002)
○ 3 (IP:172.031.003.003)
○ 4 (IP:172.031.003.004)
○ NO CONNECT
▼

SOUNDER SOURCE
▲
○ ETR0 (IP:172.031.092.001)
○ ETR1 (IP:172.031.092.011)
○ ETR2 (IP:172.031.092.012)
○ ETR3 (IP:172.031.092.013)
○ ETR4 (IP:172.031.092.014)
○ ETR5 (IP:172.031.092.015)
○ ETR6 (IP:172.031.092.016)
○ ETR7 (IP:172.031.092.017)
○ ETR8 (IP:172.031.092.018)
○ ETR9 (IP:172.031.092.019)
○ OFF
▼

12. Choose appropriate setting and then press the ENTER soft key. If you set DEVICE NO. or RADAR SOURCE, turn the power on and off again at the completion of the installation wizard.

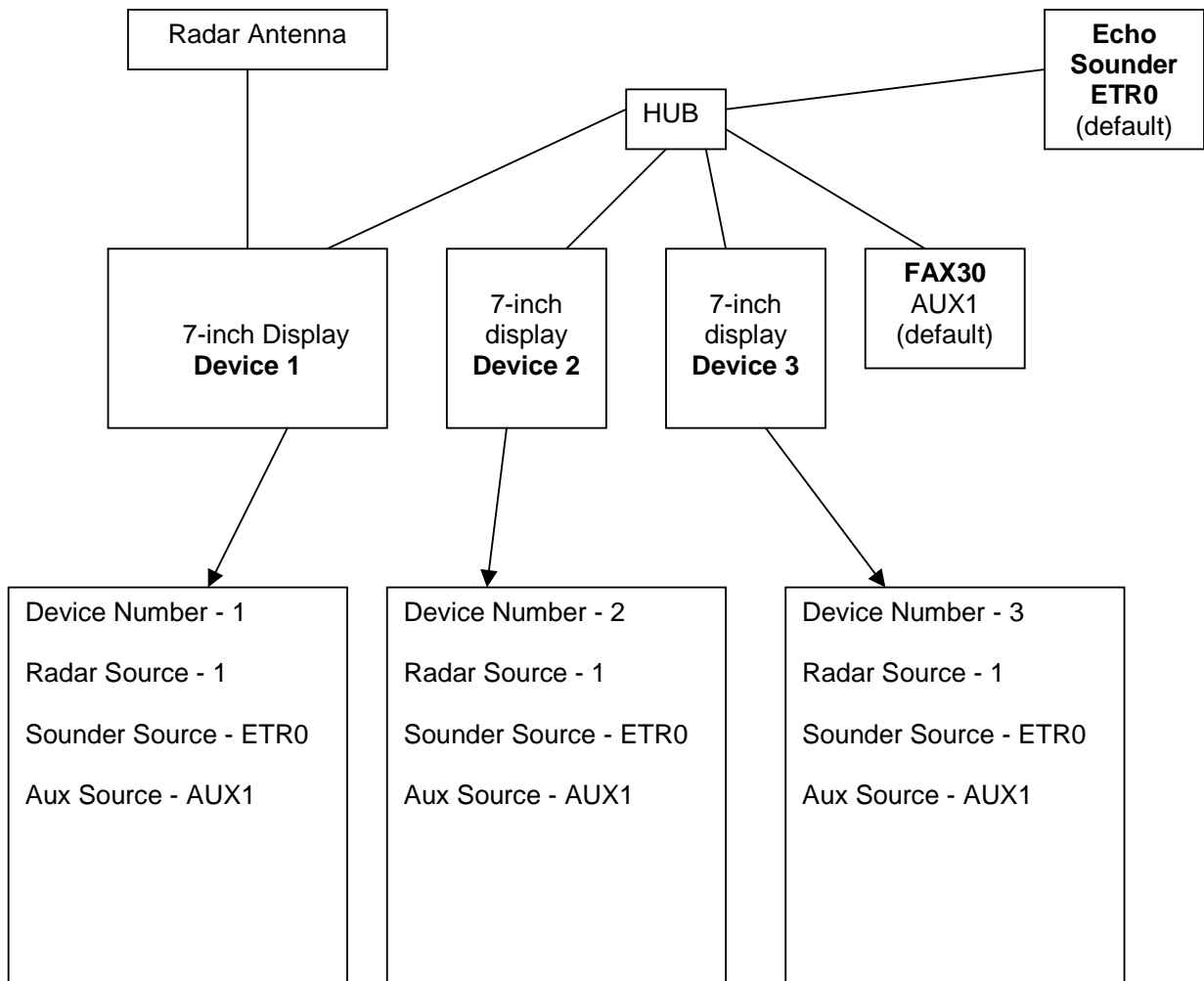

13. After choosing ALL sources, press the NEXT soft key, and the RADAR SETUP menu appears. **If you do not have a radar installed, press the NEXT soft key to show the NAV SETUP menu and go to step 25.**

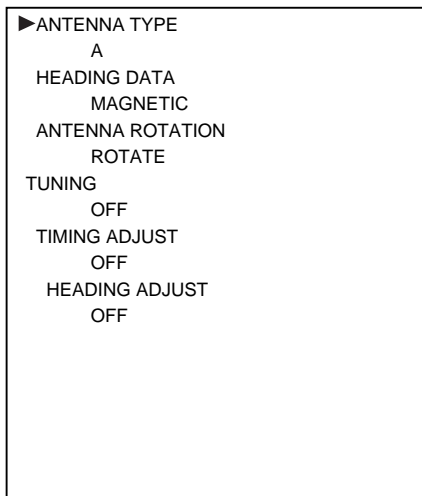

*Installation wizard, radar setup*

14. Choose ANTENNA TYPE and then press the EDIT soft key.

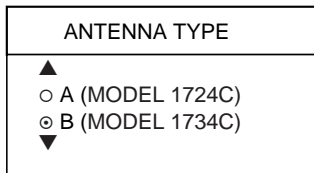

15. Choose the appropriate antenna type and then press the ENTER soft key.

16. Choose HEADING DATA and then press the EDIT soft key.

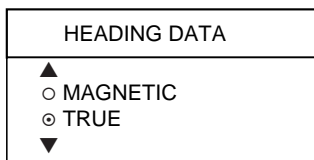

17. Choose the appropriate heading data source and then press the ENTER soft key. Select MAGNETIC when connecting with a magnetic compass, or select TRUE when connecting with a gyrocompass or satellite compass.

18. Choose ANTENNA ROTATION and then press the EDIT soft key.

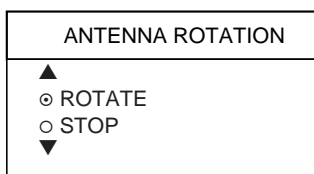

19. Confirm that ROTATE is selected and then press the ENTER soft key.

20. Choose TUNING and then press the EDIT soft key.

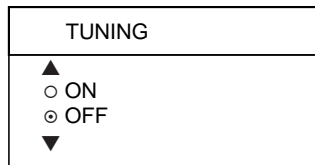

21. Choose ON and then press the ENTER soft key. Then, the radar's video and tuning are automatically adjusted.

22. After tuning has been completed, choose TIMING ADJUST and then press the EDIT soft key.

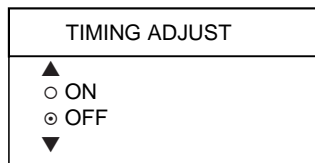

This adjustment ensures proper radar performance, especially on short ranges. The radar measures the time required for a transmitted echo to travel to the target and return to the source. The received echo appears on the display based on this time. Thus, at the instant the transmitter is fired, the sweep should start from the center of the display (sometimes called sweep origin.)

A trigger pulse generated in the display unit goes to the antenna unit through the signal cable to trigger the transmitter (magnetron). The time taken by the signal to travel up to the antenna unit varies, depending largely on the length of signal cable. During this period the display unit should wait before starting the sweep. When the display unit is not adjusted correctly, the echoes from a straight local object (for example, a harbor wall or straight pier) will not appear with straight edges – namely, they will be seen as “pushed out” or “pulled in” near the picture center. The range of objects will also be incorrectly shown.

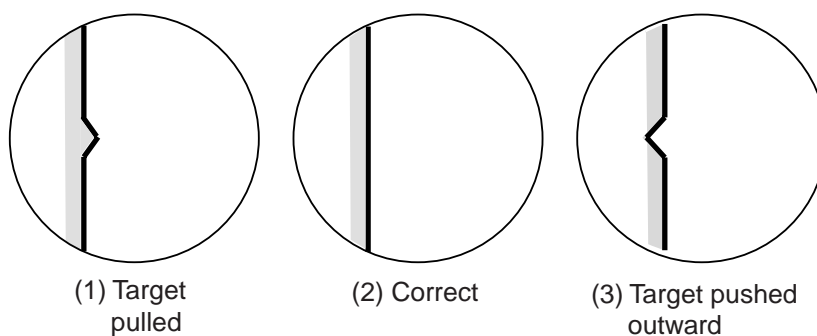

*Examples of improper and correct sweep timing*

- a) Choose ON and then press the ENTER soft key.
- b) Transmit on the shortest range and confirm that gain and A/C SEA are properly adjusted.
- c) Visually select a target which forms straight line (harbor wall, straight piers).
- d) Rotate the **ENTER** knob to straighten the target selected at step b), and then press the **ENTER** knob to finish.

23. Choose HEADING ADJUST and then press the EDIT soft key.

HEADING ADJUST
<input type="radio"/> ON <input checked="" type="radio"/> OFF

24. Choose ON and then press the ENTER soft key.

You have mounted the antenna unit facing straight ahead in the direction of the bow. Therefore, a small but conspicuous target dead ahead visually should appear on the heading line (zero degrees).

In practice, you will probably observe some small error on the display because of the difficulty in achieving accurate initial positioning of the antenna unit. The following adjustment will compensate for this error.

- Set ship's heading toward a suitable target (for example, ship or buoy) at a range between 0.125 and 0.25 nautical mile.
- Rotate the **ENTER** knob to bisect the target with the EBL and press the SET soft key.
- Press the RETURN soft key.
- As a final test, move the boat towards a small buoy and confirm that the buoy shows up dead ahead on the radar when it is visually dead ahead.

25. The next step is to choose navigation data sources and calibrate navigation data. Press the NEXT soft key to show the NAV SETUP menu.

▶ POSITION SOURCE GP SPEED SOURCE ETR TEMPERATURE SOURCE ETR DETPH SOURCE ETR STW CALIBRATION +00% TEMP CALIBRATION +00.0°F DEPTH CALIBRATION +00ft WIND AVERAGING 001 seconds(s) WIND DIRECTION OFFSET S000.0° WIND SPEED CALIBRATION +00%	
STW 12.3 kt	TEMP 56.3°F
DEPTH 99.5ft	
WIND SPEED 1.2 kt	WIND DIR 131°

*Installation wizard, nav setup*

26. Choose appropriate item and press the EDIT soft key.

27. Choose appropriate setting and then press the ENTER soft key. Refer to the table below for description of each item.

NAV SETUP menu description

Item	Description	Settings (Default in bold)
Position Source	Chooses source of position data.	FURUNO BB GPS: GPS Receiver GP-310B/320B <b>GP</b> : GPS navigator (via NETWORK or NMEA port) LC: Loran C navigator (via NETWORK or NMEA port) ALL: Multiple navaid connection (via NETWORK or NMEA port)
Speed Source	Chooses source of speed data	<b>ETR</b> (NavNet sounder), NMEA
Temperature Source	Chooses source of water temperature data.	<b>ETR</b> , NMEA. Select ETR to show water temperature data fed from the network sounder.
Depth Source	Chooses source of depth data.	<b>ETR</b> , NMEA. Select ETR to show depth data fed from the network sounder.
STW Calibration	Calibrates NMEA speed data. Enter amount in percentage.	-50 to +50%, <b>00%</b>
Temp Calibration	Calibrates NMEA temperature data. Enter offset to correct NMEA temperature data.	-20.0°C to +20.0°C (or equivalent in °F), <b>00.0°C</b>
Depth Calibration	Calibrates NMEA depth data. Enter offset to correct NMEA depth data.	-15 to +90 ft (or equivalent in m, fa or P/B). <b>00 ft</b>
Wind Averaging	Enter a value to smooth wind speed/direction data. Ship's bow is referenced to smooth wind vector movement.	001-600 s, <b>001 s</b>
Wind Direction Offset	Offsets wind direction data.	S180°-P180°, <b>S000.0°</b>
Wind Speed Calibration	Offsets NMEA wind speed data. Enter amount in percentage.	-50 to +50%, <b>00%</b>

28. After setting up navigation equipment, press the NEXT soft key, and the GPS SETUP menu appears. This menu sets up the FURUNO GPS receiver GP-310B/320B. **If you do not have this equipment, press the NEXT soft key and go to step 31.**

```

▶ GEODETIC DATUM
  WGS-84
POSITION SMOOTHING
  000 second (s)
SPD/CSE SMOOTHING
  005 second (s)
LATITUDE OFFSET
  0.000'N
LONGITUDE OFFSET
  0.000'E
DISABLE SATELLITE
- - - - -
LATITUDE
  45°35.000'N
LONGITUDE
  125°00.000'W
ANTENNA HEIGHT
  005 m
GPS FIX MODE
  2D/3D
COLD START
  NO

```

*Installation wizard, GPS setup*

29. Choose an item and press the EDIT soft key to show corresponding window.  
 30. Choose setting and then press the ENTER soft key. Refer to the table which follows for description.

*GPS SETUP menu description*

Item	Description	Settings	Default Setting
Geodetic Datum	Your equipment is preprogrammed with most of the major chart systems of the world. Although the WGS-84 system, the GPS standard, is now widely used other categories of charts still exist. Select the chart system used, not the area where your boat is sailing.	Use the cursor pad or <b>ENTER</b> knob to select appropriate chart.	WGS-84
Position Smoothing	When the DOP or receiving condition is unfavorable, the GPS fix may change, even if the vessel is dead in water. This change can be reduced by smoothing the raw GPS fixes. A setting between 000 to 999 is available. The higher setting the more smoothed the raw data, however too high a setting shows response time to change in latitude and longitude. This is especially noticeable at high ship' speeds. Increase the setting if the GPS fix changes.	0-999 sec	0 sec (no position smoothing)

*(Con't on next page)*

GPS SETUP menu description (con't from previous page)

<b>Item</b>	<b>Description</b>	<b>Settings</b>	<b>Default Setting</b>
Spd/Cse Smoothing	During position fixing, ship's velocity (speed and course) is directly measured by receiving GPS satellite signals. The raw velocity data may change randomly depending on receiving conditions and other factors. You can reduce this random variation by increasing the smoothing. Like with latitude and longitude smoothing, the higher the speed and course smoothing the more smoothed the raw data. If the setting is too high, however, the response to speed and course change slows. For no smoothing, enter all zeros.	0-999 sec	5 sec
Latitude Offset	Offsets latitude position to further refine position accuracy. Use the N <- -> S soft key to switch coordinate.	9.999'S – 9.999'N	0.0' (no offset)
Longitude Offset	As above but for longitude. Use the W <- -> E soft key to switch coordinate.	9.999'E – 9.999'W	0.0' (no offset)
Disable Satellite	Every GPS satellite is broadcasting abnormal satellite number (s) in its Almanac, which contains general orbital data about all GPS satellites, including those which are malfunctioning. Using this information, the GPS receiver automatically eliminates any malfunctioning satellite from the GPS satellite schedule. However, the Almanac sometimes may not contain this information. If you hear about a malfunctioning satellite from another source, you can disable it manually. Enter satellite number (max. 3 satellites) in two digits and press the ENTER soft key.		None
Latitude	Set initial latitude position after cold start. Use the N <- -> S soft key to switch coordinate.	90°S - 90°N	45°35.000'N
Longitude	Set initial longitude position after cold start. Use the W <- -> E soft key to switch coordinate.	180°E – 180°W	125°00.000W
Antenna Height	Enter the height of the GPS antenna unit above sea surface.	0-99 m	5 m

*(Con't on next page)*

GPS SETUP menu description (con't from previous page)

Item	Description	Settings	Default Setting
Fix Mode	Choose position fixing method: 2D (three satellites in view), 2D/3D (three or four satellites in view whichever is greater).	2D, 2D/3D	2D/3D
Cold Start	Clears the Almanac to receive the latest Almanac.	No, Yes	No

**WAAS setup**

Press the WAAS SETUP soft key at the GPS SETUP menu to show the WAAS SETUP display.

Contents of WAAS SETUP menu

Item	Description	Settings	Default Setting
WAAS Mode	Select ON to use the WAAS mode.	On, Off	Off
WAAS Search	WAAS satellite can be searched automatically or manually. For manual search, enter appropriate WAAS satellite number.	Auto, Manual	Auto
WAAS Alarm	When the WAAS signal is lost, the audible alarm sounds with the visual message "NO WAAS SIGNAL." <b>On:</b> Alarm continues to sound until the WAAS positioning mode is available again or the alarm is recognized by key operation. <b>Off:</b> Alarm sounds three times.	On, Off	Off
Corrections Data	Selects the type of message for WAAS correction. Use "00" (operational status) in North America; "02" in other locations.	00 to 27, 99	02

31. After you have finished setting up the GPS receiver GP-310B/320B, it's now time to set up external equipment. Press the NEXT soft key to show the DATA1 (GPS/NMEA) port setup menu. It is only necessary to set up ports which you are going to use; skip unnecessary steps. **If you do not have external equipment connected to the NavNet, press the NEXT key several times to show the "FINISH AND EXIT INSTALLATION WIZARD" screen and then push the ENTER knob to finish.**

▶ OUTPUT FORMAT NMEA0183 2.0 BAUD RATE 4800bps LAT/LON FORMAT DD°MM.MMM' XTE FORMAT X. XX OUTPUT DESTINATION NO
--

*Installation wizard, DATA1 (GPS/NMEA) port setup menu*



32. Choose item and press the EDIT soft key. Choose appropriate setting and then press the ENTER soft key. Refer to the table and sentence description on the next page for details.
33. Press the NEXT key, and the DATA3 (PC/NMEA/EXT BUZZ) port setup menu appears. Set up this port similar to how you set up the DATA1 port.

```

▶ NMEA OUTPUT FORMAT
  NMEA Ver 2.0
BAUD RATE
  4800bps
BIT LENGTH
  8 bits
STOP BIT
  1 bit
PARITY
  NONE

(Control: Xon/Xoff)

```

*Installation wizard, DATA3 (PC/NMEA/EXT BUZZ) port setup menu*

Description of items in “port” menus

Item	Description	Settings	Default Setting
Output Format (DATA1 port), NMEA Output Format (DATA3 port)	Selects NMEA output version for the equipment connected.	NMEA0183 Ver. 1.5, NMEA0183 Ver. 2.0	NMEA0183 Ver. 2.0
Baud Rate	Choose baud rate of equipment connected.	<b>DATA1 port:</b> AUTO* <sup>1</sup> , 4800 and 38400* <sup>2</sup> (bps) <b>DATA3 port:</b> 4800, 9600, 19200 (bps)	4800
Lat/Lon Format	Selects latitude/longitude format to output.	DD°MM.MM', DD°MM.MMM', DD°MM.MMMM'	DD°MM.MMM'
XTE Format	Selects number of XTE digits to output.	X. XX, X. XXX	X. XX
Output Destination	Selects whether to output route (data sentence RTE) and waypoint data (data sentence WPL) when destination is set.	Yes, No	No
Bit Length	Choose bit length of equipment connected.	7, 8 (bits)	7 bits
Stop Bit	Choose stop bit of equipment connected.	1, 2 (bits)	1 bit
Parity	Choose parity of equipment connected.	Even, Odd, None	None
PORT MNITR (soft key)	Use this key to view which sentences are being output. See the example on then next page		

\*<sup>1</sup> Auto detection of baud rate of connected equipment. For use only with device having “AUTO” feature.

\*<sup>2</sup> Choose 38400 bps when connecting an AIS Interface or AIS Transponder to the DATA1 port.

```

$GPGLL,3415.2345,N,13520.5301,E,152500.00
,A*E7<CR><LF>$GPGLL,3415.2345,N,135
20.5301,E,152500.00,A*E7<CR><LF>$GPGLL
,3415.2345,N,13520.5301,E,152500.00,A*
E7<CR><LF>$GPGLL,3415.2345,N,13520.530
1,E,152500.00,A*E7<CR><LF>$GPGLL,3415.
2345,N,13520.5301,E,152500.00,A*E7<CR>
<LF>$GPGLL,3415.2345,N,13520.5301,E,15
2500.00,A*E7<CR><LF>

```

*Installation wizard, port monitor display*

34. Press the NEXT soft key, and the NMEA sentence selection window appears.

▶ AAM	--
APB	--
BOD	--
BWR	--
DPT	--
GGA	--
GLL	--
GTD	--
MTW	--
RMA	--
RMB	--
RMC	--
VHW	--
VTG	--
WPL	--
XTE	--
ZDA	--
HDT	--
HDG	--
MWV	--
ZTG	--

*Installation wizard, NMEA sentence selection window*

35. Choose sentence to process and press the ON/OFF soft key to show ON (to output data) or “- -” (OFF) as appropriate.

36. Press the NEXT soft key and the message “FINISH AND EXIT INSTALLATION WIZARD. ARE YOU SURE?” appears. Press the **ENTER** knob to finish the installation wizard.

This concludes the Installation Wizard. Turn off the equipment to register settings.

## 3.2 Checking Magnetron Heater Voltage

Magnetron heater voltage is formed on the PTU or MD Board of the antenna unit, and preadjusted at the factory. Therefore, no adjustment is required. However, check magnetron heater voltage for confirmation as follows. ***This procedure should only be performed by a qualified technician.***

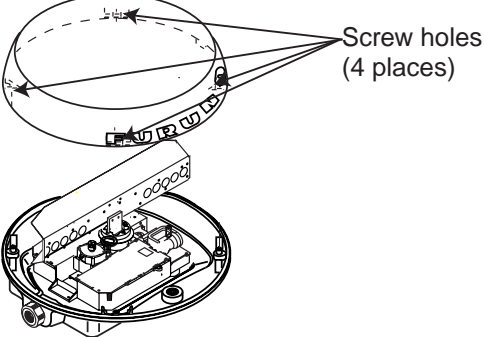
<b>NOTICE</b>	
<p><b>For MODEL1724C, lift the radome cover slowly.</b></p> <p>The antenna radiator may be caught by the screw holes in the radome cover. If you feel the radiator is caught by the screw holes, lower the cover, turn it a few degree and then lift it again.</p>	

1. Open the antenna unit.
2. Turn on the power. Do not transmit the radar.
3. Connect a multimeter, set to 10VDC range, to appropriate test point on the MD Board (MODEL 1724C) or PTU Board (MODEL 1734C) Board in the antenna unit, referring to the table below for test points.
4. Confirm that the multimeter indication is as shown in the table.

	<b>MODEL 1724C</b>	<b>MODEL 1734C</b>
Check point	TP804#6(+) and #4(-) on MD Board	TP802#4(+) and #6(-) on PTU Board
Multimeter indication	7.9 to 8.1 V	7.4 to 7.6 V
Adjustment point	VR801 on MD Board	R106 on PTU Board

### 3.3 Remote Controller Setting

A remote controller can be set exclusively for use with a specific display unit, in the case of multiple NavNet display units. Set the remote controller ID mode desired on the menu and attach appropriate label (supplied with accessories) to the remote controller and display unit.

1. Press the **MENU** key followed by the SYSTEM CONFIGURATION and GENERAL SETUP soft key to show the GENERAL SETUP menu.

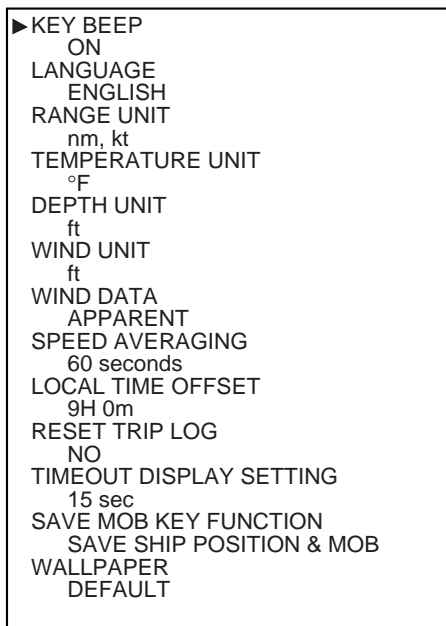

Page 1

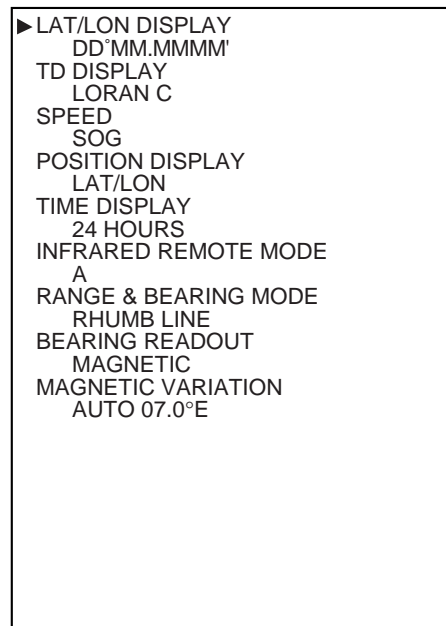

Page 2

*GENERAL SETUP menu*

2. Press the NEXT PAGE soft key to show Page 2.
3. Choose INFRARED REMOTE MODE, and press the EDIT soft key to show the I/R REMOTE MODE window.

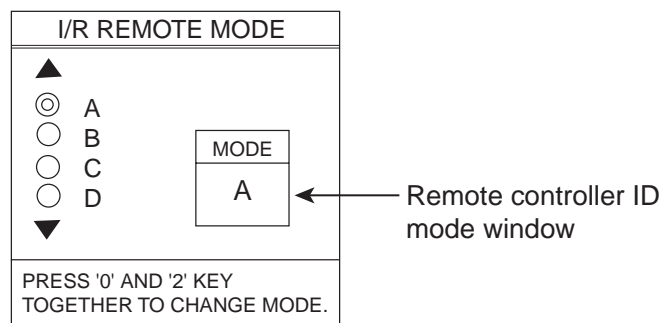





*I/R REMOTE MODE window*

4. Point the remote controller toward the display unit, and then press any key on the remote controller. Preset mode appears in the remote controller ID mode window.
5. After the confirmation of the remote controller mode on the window appears, press the [0] and [2] key together on the remote controller to change the controller ID mode setting among A, B, C and D.
6. Operate the trackball so that the display ID is the same as the controller mode setting.
7. Press the **MENU** key to close the menu.

# PACKING LIST RDP-148-E-\*-CS

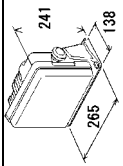
19AW-X-9851-4

1/1

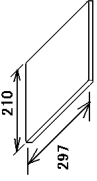
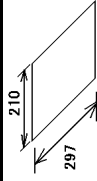
NAME	OUTLINE	DESCRIPTION/CODE	Q'TY
<b>ユニット</b>			
指示部 DISPLAY UNIT		RDP-148-E-N 000-088-270-00**	1
<b>リモコンセット</b>			
リモコンセット REMOTE CONTROLLER SET		RMC-100-E 000-089-885-00	1
<b>予備品</b>			
予備品 SPARE PARTS		SP03-15201 008-547-740-00	1
<b>工事材料</b>			
<b>INSTALLATION MATERIALS</b>			
工事材料 INSTALLATION MATERIALS		CP03-22201 008-523-670-00	1
ケーブル組品MJ CABLE ASSY.		MJ-A3SPF0016-035C 000-154-024-10	1
<b>図書</b>			
<b>DOCUMENT</b>			
SIRIUS操作マニュアル SIRUS REFERENCE MANUAL		E32-00701- 000-166-955-1*	1 (*1)
ヒューズ 変更のお願い NOTICE FOR FUSE REPLACEMENT		C32-00007- 000-809-188-1*	1



1.コード番号末尾の[\*1]は、選択品の代表型式/コードを表します。

CODE NUMBER ENDING WITH "\*\*\*\*\*" INDICATES THE CODE NUMBER OF REPRESENTATIVE MATERIAL.

2.GD-1720Cで使用時、工事材料CP03-22201内のナットM3X8 4枚は使用しません。

FOR GD-1720C,FOUR(4) PAN HEAD SCREWS(M3X8) IN INSTALLATION MATERIALS CP03-22201 ARE NOT USED.

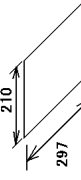
(略図の寸法は、参考値です。DIMENSIONS IN DRAWING FOR REFERENCE ONLY.)

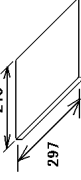
NAME	OUTLINE	DESCRIPTION/CODE	Q'TY
フラッシュマウント型紙 FLASH MOUNTING TEMPLATE		C32-00510- 000-156-388-1*	1
操作要領書 OPERATOR'S GUIDE		OS*-35550- 000-151-810-1*	1
装備要領書 INSTALLATION MANUAL		IM*-35550- IM*-35550- 000-151-809-1* 000-151-809-0*	1
取扱説明書 OPERATOR'S MANUAL		OM*-35550- OM*-35550- 000-151-808-1* 000-151-808-0*	1

3.(\*1)の図書は、C-MAP仕様のみ必要です。

(\*1) C-MAP SPECIFICATION ONLY.

型式/コード番号が2段の場合、下段より上段に代わる過渡期品であり、どちらかが入っています。なお、品質は変わりません。

TWO TYPES AND CODES MAY BE LISTED FOR AN ITEM. THE LOWER PRODUCT MAY BE SHIPPED IN PLACE OF THE UPPER PRODUCT. QUALITY IS THE SAME.

19AW-X-9851

## PACKING LIST

RSB-0071-058

NAME	OUTLINE	DESCRIPTION/CODE No.	QTY
<b>ユニット</b>			
空中線部 ANTENNA UNIT		RSB-0071-058 000-086-822-00	1
<b>空中線部工材</b>			
ANTENNA UNIT INSTALLATION MATERIALS			
EMCコア		E04SS251512 000-144-673-00	1
六角ボルト 刈割		M10X25 SUS304 000-862-308-00	4
六角ボルト (SLOTTED HEAD)		M10 SUS304 000-864-131-00	4
フラットワッシャー		M10 SUS304 000-864-261-00	4
スプリングワッシャー			

型式コード番号が2段の場合、下段より上段に代わる過渡期品であり、どちらが入っています。なお、品質は変わりません。  
TWO TYPES AND CODES MAY BE LISTED FOR AN ITEM. THE LOWER PRODUCT MAY BE SHIPPED IN PLACE OF THE UPPER PRODUCT. QUALITY IS THE SAME.  
(略図の寸法は、参考値です。DIMENSIONS IN DRAWING FOR REFERENCE ONLY.)

19AK-X-9854

## PACKING LIST

RSB-110-070-A

NAME	OUTLINE	DESCRIPTION/CODE No.	QTY
<b>ユニット</b>			
空中線部 ANTENNA UNIT		RSB-110-070-A 000-080-238-00	1
<b>工事材料</b>			
INSTALLATION MATERIALS			
ワッシャーヘッドネジ		M4X15 C2700W MBN12 000-881-448-00	1
EMCコア		RFC-10 000-141-085-10	1
コリ取付板		03-146-0101-0 100-277-850-00	1
六角ボルト 刈割		M10X25 SUS304 000-862-308-00	4
六角ボルト (SLOTTED HEAD)			

型式コード番号が2段の場合、下段より上段に代わる過渡期品であり、どちらが入っています。なお、品質は変わりません。  
TWO TYPES AND CODES MAY BE LISTED FOR AN ITEM. THE LOWER PRODUCT MAY BE SHIPPED IN PLACE OF THE UPPER PRODUCT. QUALITY IS THE SAME.  
(略図の寸法は、参考値です。DIMENSIONS IN DRAWING FOR REFERENCE ONLY.)

19AP-X-9851

# FURUNO

## 工事材料表

MODEL1722/1720C/1720C Model 1724C		CODE NO.	19AK-X-9401 -1	1/1
INSTALLATION MATERIALS		TYPE		
番号 NO.	名称 NAME	型名/規格 DESCRIPTIONS	数量 Q'TY	用途/備考 REMARKS
1	信号ケーブル組品 SIGNAL CABLE ASSY. L=5M	S03-87-5 CODE NO. 008-523-080-00	1	選択 TO BE SELECTED
2	信号ケーブル組品 SIGNAL CABLE ASSY. L=10M	S03-87-10 CODE NO. 008-523-090-00	1	選択 TO BE SELECTED
3	信号ケーブル組品 SIGNAL CABLE ASSY. L=15M	S03-87-15 CODE NO. 008-523-100-00	1	選択 TO BE SELECTED
4	信号ケーブル組品 SIGNAL CABLE ASSY. L=20M	S03-87-20 CODE NO. 008-523-110-00	1	選択 TO BE SELECTED
5	信号ケーブル組品 SIGNAL CABLE ASSY. L=30M	S03-87-30 CODE NO. 008-523-120-00	1	選択 TO BE SELECTED

型式/コード番号が異なる取付の場合、下取より上取に代わる過渡期品であり、どちらかが入っています。なお、品質は変わりません。  
TWO TYPES AND CODES MAY BE LISTED FOR AN ITEM. THE LOWER PRODUCT MAY BE SHIPPED IN PLACE OF THE UPPER PRODUCT.  
QUALITY IS THE SAME.  
(略図の寸法は、参考値です。 DIMENSIONS IN DRAWING FOR REFERENCE ONLY.)

# FURUNO

## 工事材料表

MODEL1732/1732C/1733C Model 1734C		CODE NO.	19AK-X-9402 -1	1/1
INSTALLATION MATERIALS		TYPE		
番号 NO.	名称 NAME	型名/規格 DESCRIPTIONS	数量 Q'TY	用途/備考 REMARKS
1	信号ケーブル組品 SIGNAL CABLE ASSY. L=10M	S03-88-10 CODE NO. 008-523-130-00	1	選択 TO BE SELECTED
2	信号ケーブル組品 SIGNAL CABLE ASSY. L=15M	S03-88-15 CODE NO. 008-523-140-00	1	選択 TO BE SELECTED
3	信号ケーブル組品 SIGNAL CABLE ASSY. L=20M	S03-88-20 CODE NO. 008-523-150-00	1	選択 TO BE SELECTED
4	信号ケーブル組品 SIGNAL CABLE ASSY. L=30M	S03-88-30 CODE NO. 008-523-160-00	1	選択 TO BE SELECTED

型式/コード番号が異なる取付の場合、下取より上取に代わる過渡期品であり、どちらかが入っています。なお、品質は変わりません。  
TWO TYPES AND CODES MAY BE LISTED FOR AN ITEM. THE LOWER PRODUCT MAY BE SHIPPED IN PLACE OF THE UPPER PRODUCT.  
QUALITY IS THE SAME.  
(略図の寸法は、参考値です。 DIMENSIONS IN DRAWING FOR REFERENCE ONLY.)

# FURUNO

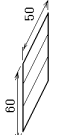
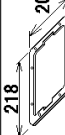
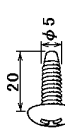
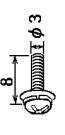
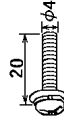
CODE NO.		TYPE		19AW-X-9401-3		1/1	
009-523-670-00		CP03-22201					
工事材料表							
INSTALLATION MATERIALS							
番号 NO.	名称 NAME	略図 OUTLINE	型名/規格 DESCRIPTIONS	数量 QTY	用途/備考 REMARKS		
1	ヒューズ FUSE LABEL		03-163-1312-0 ROHS CODE NO. 100-292-140-10	1			
2	フラッシュマウントスポンジ FLUSH MOUNTING SPONGE		03-164-140-0 ROHS CODE NO. 100-323-870-10	1			
3	セルフタッピングビス SELF-TAPPING SCREW		5X20 SUS304 CODE NO. 1000-162-608-10	4			
4	ワッシャー WASHER HEAD SCREW		M3X8 SUS304 CODE NO. 1000-162-648-10	4			
5	ワッシャー WASHER HEAD SCREW *B*		M4X20 SUS304 CODE NO. 1000-162-662-10	6			

型式/コード番号が2股の場合、下股より上股に代わる過渡品であり、どちらかが入っています。なお、品質は変わりありません。  
TWO TYPES AND CODES MAY BE LISTED FOR AN ITEM. THE LOWER PRODUCT MAY BE SHIPPED IN PLACE OF THE UPPER PRODUCT. QUALITY IS THE SAME.  
(略図の寸法は、参考値です。 DIMENSIONS IN DRAWING FOR REFERENCE ONLY.)

# FURUNO

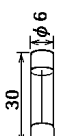
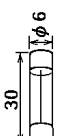
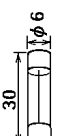
CODE NO.		TYPE		008-547-740		19AW-X-9301-2, 1/1	
				SP03-15201		BOX NO. P	
SHIP NO. SPARE PARTS LIST FOR U S E							
REMARKS/CODE NO.							
ITEM NO.	NAME OF PART	OUTLINE	DWG. NO. OR TYPE NO.	QUANTITY	WORKING PER SET	SPARE	REMARKS/CODE NO.
1	ヒューズ FUSE		FB80 125V 10A PBF			3	000-155-826
2	ヒューズ FUSE		FB80 250V 5A PBF			3	000-155-840
3	ヒューズ FUSE		FB80 250V 3A PBF			3	000-155-841
MFR'S NAME	FURUNO ELECTRIC CO., LTD.			DWG. NO.	19AW-X-9301	1/1	

(略図の寸法は、参考値です。 DIMENSIONS IN DRAWING FOR REFERENCE ONLY.)





表 1 TABLE 1

寸法区分 (mm) DIMENSIONS	公差 (mm) TOLERANCE
L ≤ 50	± 1.5
50 < L ≤ 100	± 2.5
100 < L ≤ 500	± 3

注 記 1) #印寸法は最小サービスペースとする。

2) 指定外寸法公差は表 1 による。

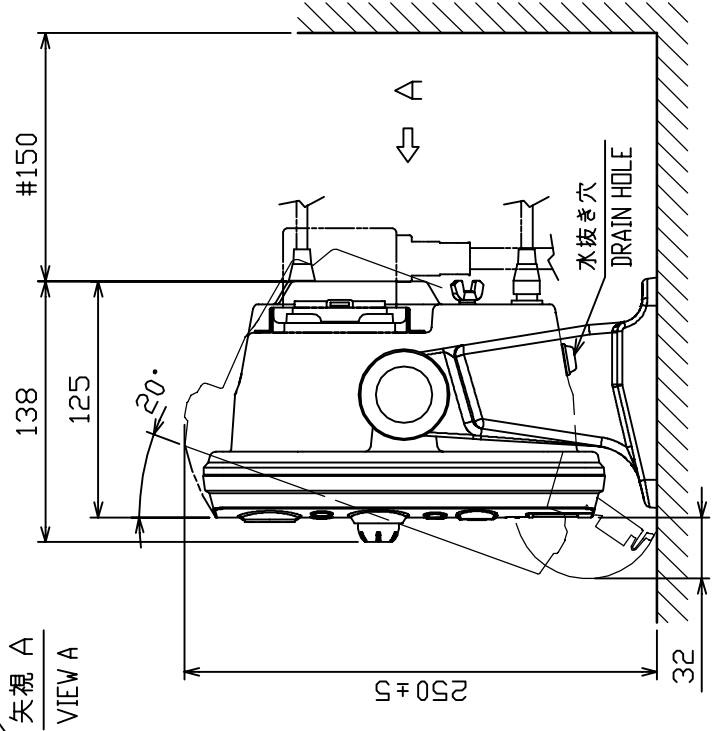
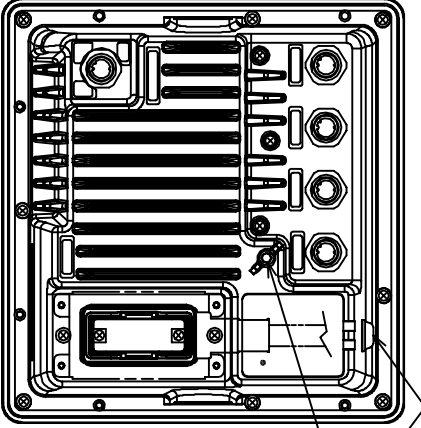
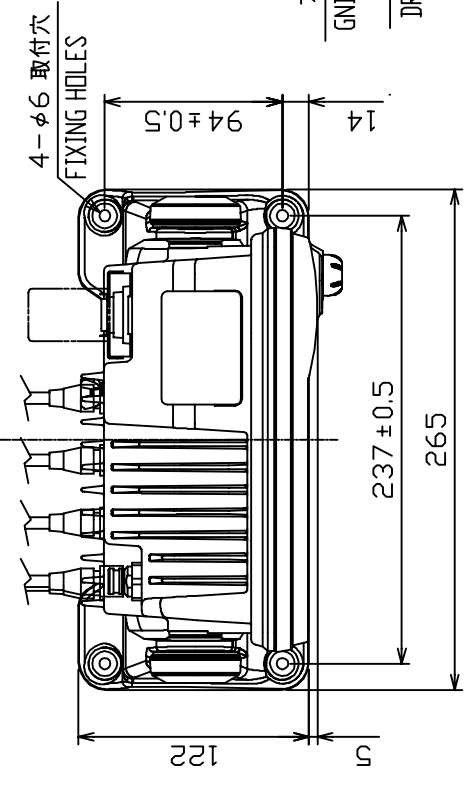
3) 取付用ネジは+トラスチックピンネジ呼び径5×20を使用のこと。

NOTE

1. #: MINIMUM SERVICE CLEARANCE.

2. TABLE 1 INDICATES TOLERANCE OF DIMENSIONS WHICH IS NOT SPECIFIED.

3. USE TAPPING SCREWS 5x20 FOR FIXING THE UNIT.

DRAWN	Jan. 20, '05	E. MIYOSHI	TITLE	RDP-130/131/143/148
CHECKED		TAKAHASHI, T	名称	指示部 (卓上装備)
APPROVED		Y. Hatai	外寸図	
SCALE	1/4	MASS 3.3 kg	NAME	DISPLAY UNIT (DESKTOP MOUNT)
DWG.No.	C3494-G01-F	03-153-100G-5		OUTLINE DRAWING

表 1 TABLE 1

寸法区分 (m.m) DIMENSIONS	公差 (m.m) TOLERANCE
L ≤ 50	± 1.5
50 < L ≤ 100	± 2.5
100 < L ≤ 500	± 3

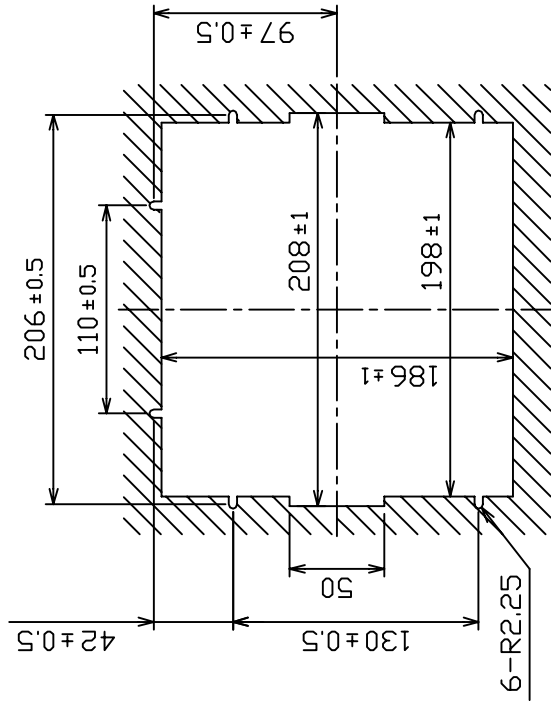
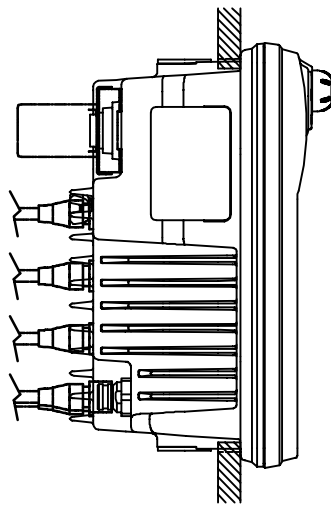

取付穴寸法図 CUTOUT DIMENSIONS

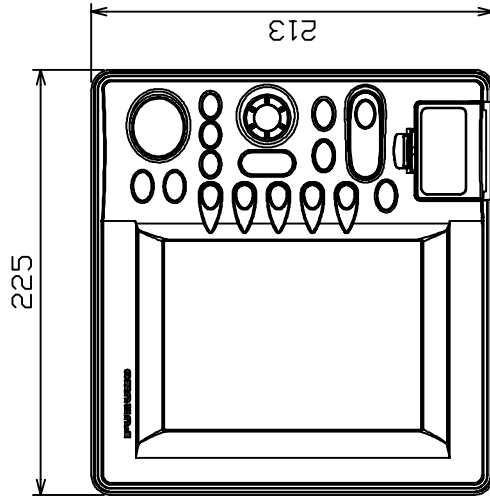
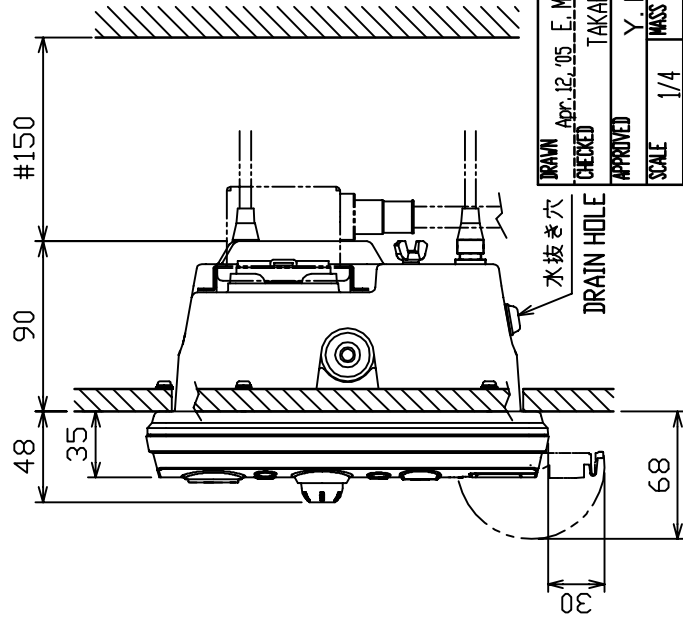

注 記 1) #印寸法は最小サービスペースとする。

2) 指定外寸法公差は表 1 による。

3) 取付用ネジはセムスネジ B M4×2.0 を使用のこと。

壁の厚さ (A) は最小 11 最大 14 とする。

上記以外の壁に装着する場合、使用するネジの長さは

(A+7.3)±1.5 とする。(セムスネジ B を使用)

筐体にはネジ部を 7mm 以上いれないこと。(B ≤ 7)

NOTE 1. # MINIMUM SERVICE CLEARANCE.

2. TABLE 1 INDICATES TOLERANCE OF DIMENSIONS WHICH IS NOT SPECIFIED.

3. USE M4x2.0 SCREWS FOR FIXING THE UNIT.

THICKNESS A: 11 ≤ A ≤ 14 OR SCREW LENGTH: (A+7.3) ± 1.5.

DO NOT FASTEN SCREWS INTO UNIT MORE THAN 7mm. (B ≤ 7)

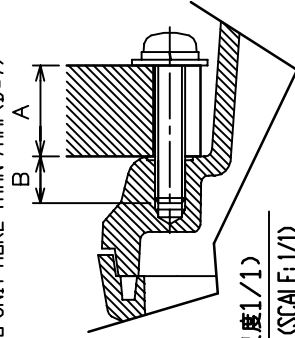

取付ネジ部断面 (尺度 1/1)

DETAIL OF FASTENING (SCALE: 1/1)

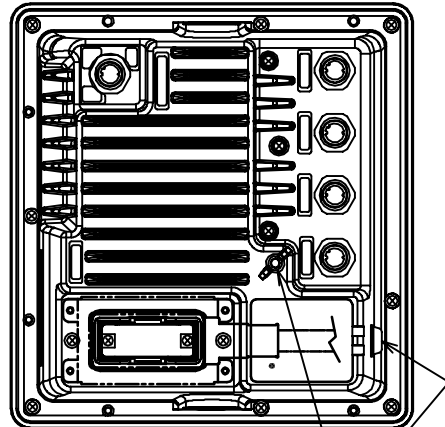

7-ス端子

GND TERMINAL

水抜き穴

DRAIN HOLE

DRAWN	Apr. 12. 05	E. MIYOSHI	TITLE	RDP-130/131/143/148
CHECKED		TAKAHASHI, T.	名称	指示部 (埋込装置)
APPROVED		Y. Hatai	外寸図	
SCALE	1/4	WAS 30	NAME	DISPLAY UNIT (FLUSH MOUNT)
DWG No.	C3494-602-F			OUTLINE DRAWING

表2 TABLE 2

MODEL	MASS (kg ±0.1%)
RSB-0087/0087A/110	4.9
RSB-0094	5.2
RSB-0095	5.1

表1 TABLE 1

寸法区分(mm)	公差(mm)
DIMENSIONS	TOLERANCE
0 < L ≤ 50	±1.5
50 < L ≤ 100	±2.5
100 < L ≤ 500	±3

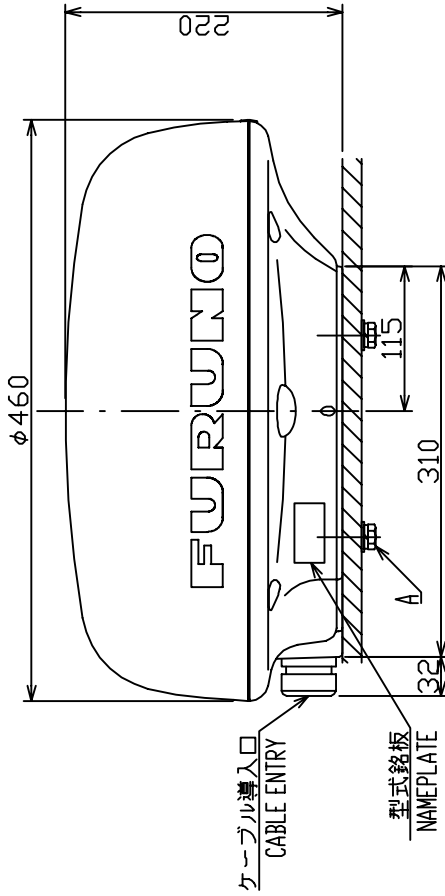
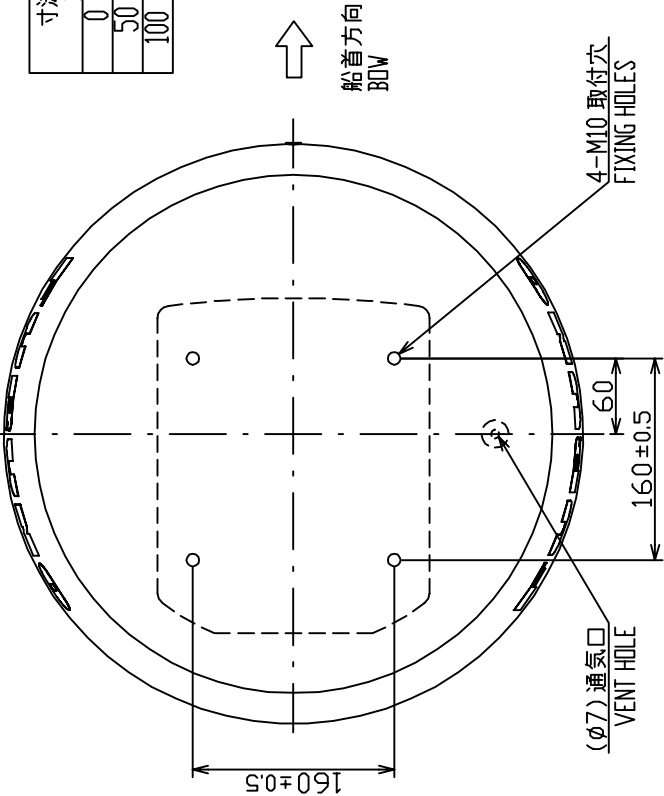
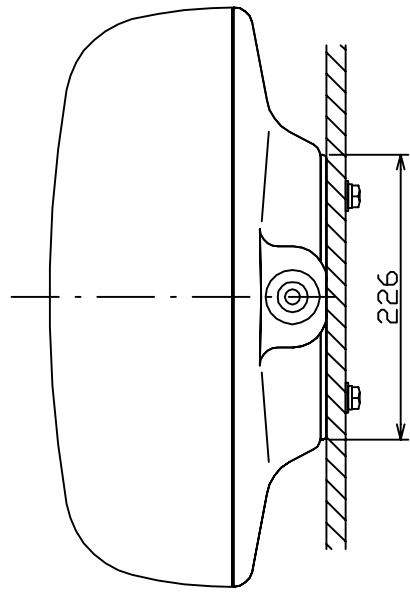
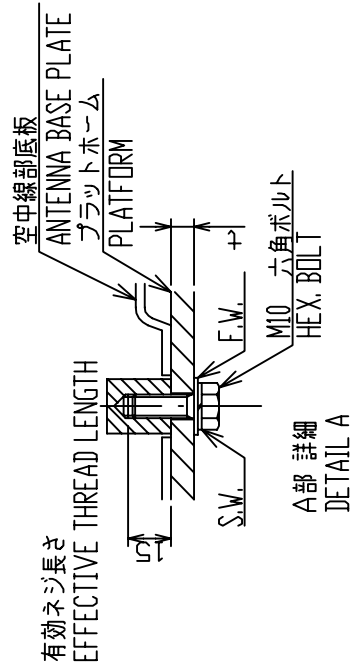

注記 1) 指定外の寸法公差は表1による。

2) 取付はM10ボルトを使用のこと。

ネジ長さは板厚に依りて、20 (t ≤ 5) または 25 (5 < t ≤ 10) とする。

NOTE 1. TABLE 1 INDICATES TOLERANCE OF DIMENSIONS WHICH IS NOT SPECIFIED.

2. USE M10 BOLTS FOR FIXING UNIT.

SCREW LENGTH SHALL BE ACCORDING TO PLATFORM THICKNESS;

20 (t ≤ 5) OR 25 (5 < t ≤ 10).

DRAWN	Y. Hatai	MODEL 1724C	TITLE	RSB-0087/0087A/0094/0095/110
CHECKED	TAKAHASHI, T	MODEL 1824C/1824C-BB	名称	空中線部
APPROVED	Y. Hatai	MODEL 1823C	外寸図	
SCALE	1/6	MODEL 1722/1722C/1723C	NAME	ANTENNA UNIT
DWG No.	C3489-G02-H	MODEL 172		OUTLINE DRAWING
		03-161-100G-3/03-164-300G-1		



表1 TABLE 1

寸法区分(mm) DIMENSIONS	公差(mm) TOLERANCE
0 < L ≤ 50	±1.5
50 < L ≤ 100	±2.5
100 < L ≤ 500	±3
500 < L ≤ 1000	±4

注記  
指定外の寸法公差は表1による。

NOTE  
TABLE 1 INDICATES TOLERANCE OF DIMENSIONS WHICH IS NOT SPECIFIED.

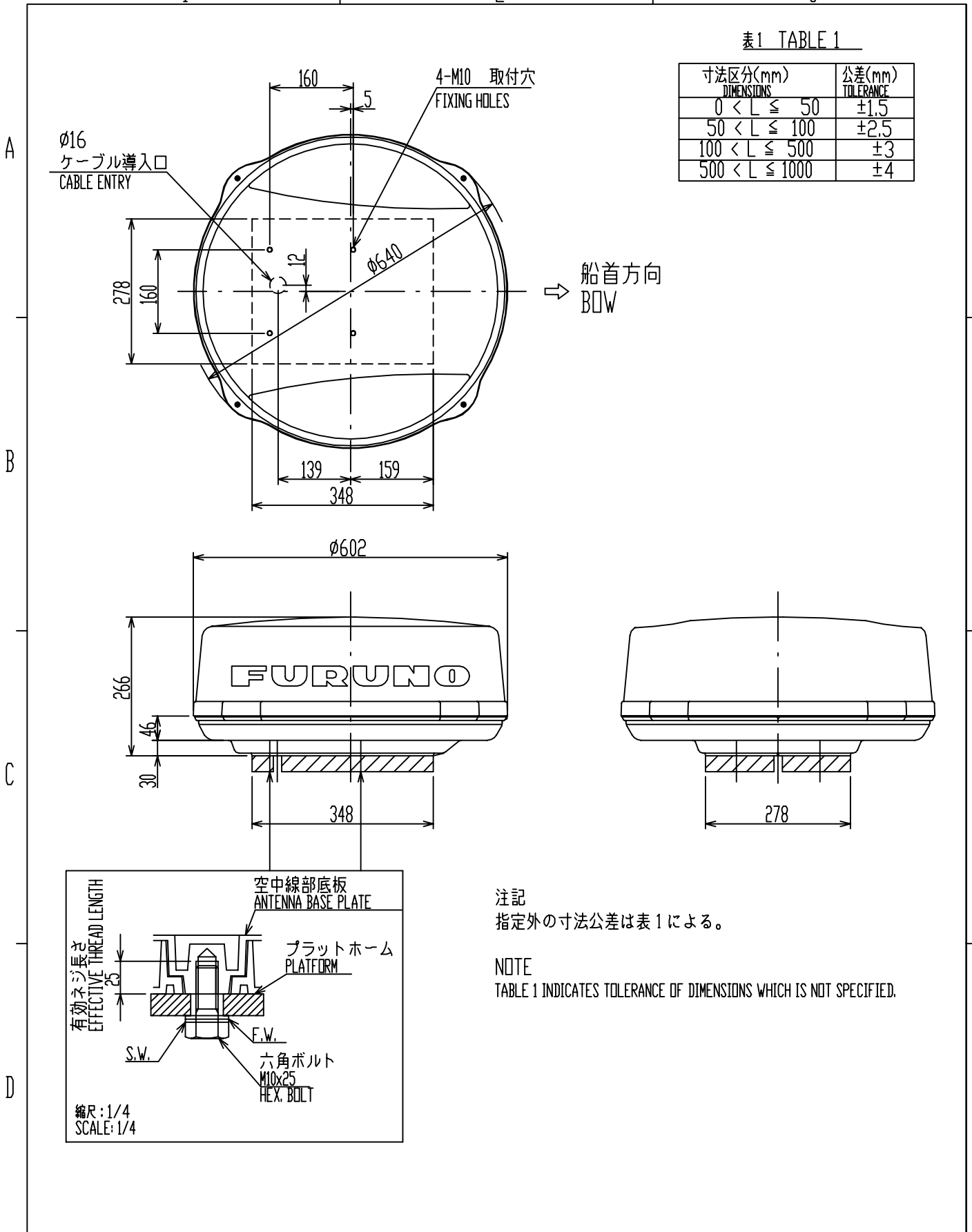
DRAWN Feb. 3, '05	E. MIYOSHI	MODEL 1734C MODEL 1834C/1834C(-BB)	TITLE RSB-0071
CHECKED	TAKAHASHI, T	MODEL 1833/1833C MODEL 1732/1732C	名称 空中線部
APPROVED	Y. Hatai	RS-1000 MODEL 1832	外寸図
SCALE 1/10	MASS 8 ±10% kg		NAME ANTENNA UNIT
DWG.No. C3441-G01-G		03-136-6001-G2	OUTLINE DRAWING

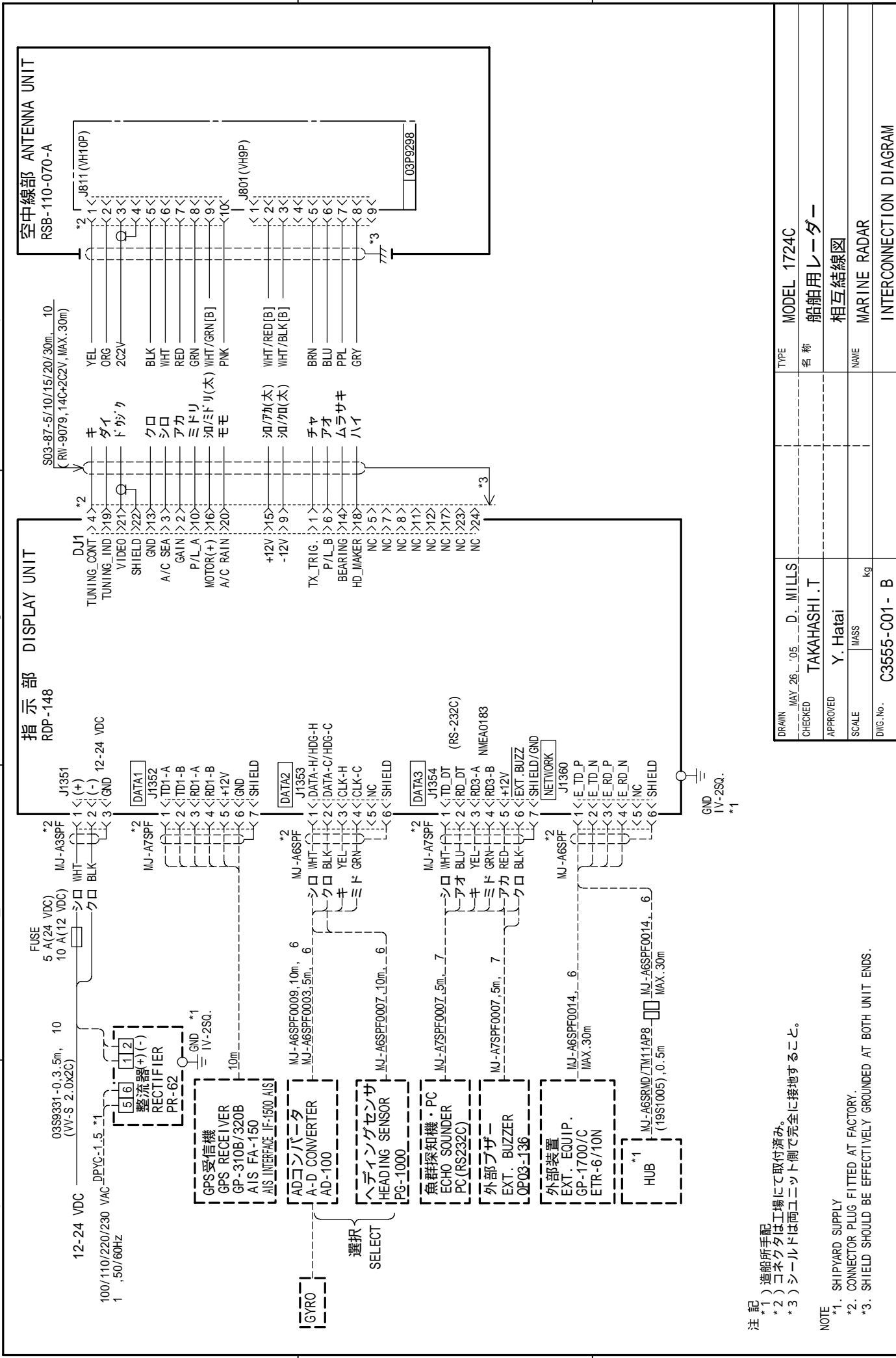

DRAWN	MAY 26 05	D. MILLS	TYPE	MODEL 1724C
CHECKED		TAKAHASHI, T	名称	船舶用レーダー
APPROVED		Y. Hatai		相互結線図
SCALE		MASS kg	NAME	MARINE RADAR
DWG. No.		C3555-C01 - B		INTERCONNECTION DIAGRAM

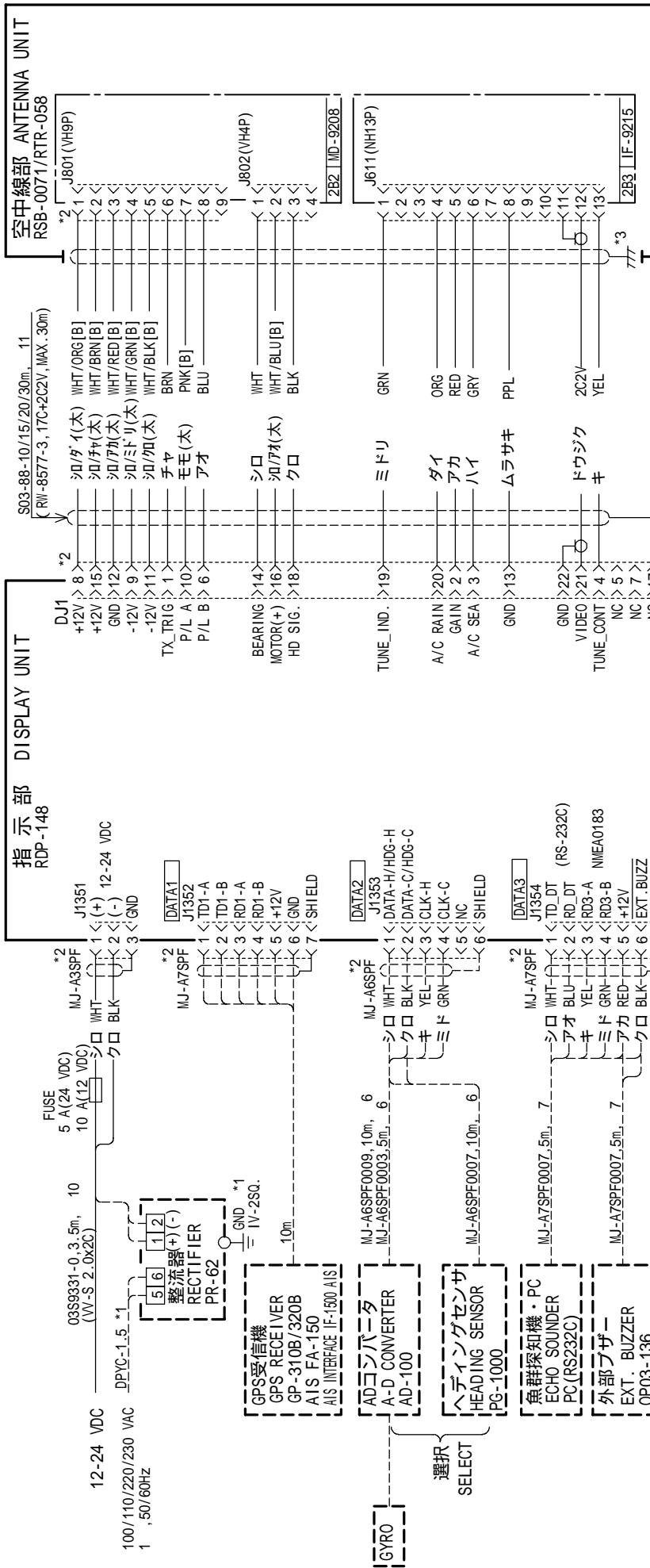

DRAWN	MAY 20 '05	D. MILLS	TYPE	MODEL 1734C
CHECKED		TAKAHASHI, T	名称	船舶用レーダー
APPROVED		Y. Hatai		相互結線図
SCALE		MASS	NAME	MARINE RADAR
DWG. No.		kg		INTERCONNECTION DIAGRAM
		C3556-C01-B		

注記  
 \*1) 造船所手配  
 \*2) コネクタは工場にて取付済み。  
 \*3) シールドは両ユニット側で完全に接地すること。

NOTE  
 \*1. SHIPYARD SUPPLY  
 \*2. CONNECTOR PLUG FITTED AT FACTORY.  
 \*3. SHIELD SHOULD BE EFFECTIVELY GROUNDED AT BOTH UNIT ENDS.

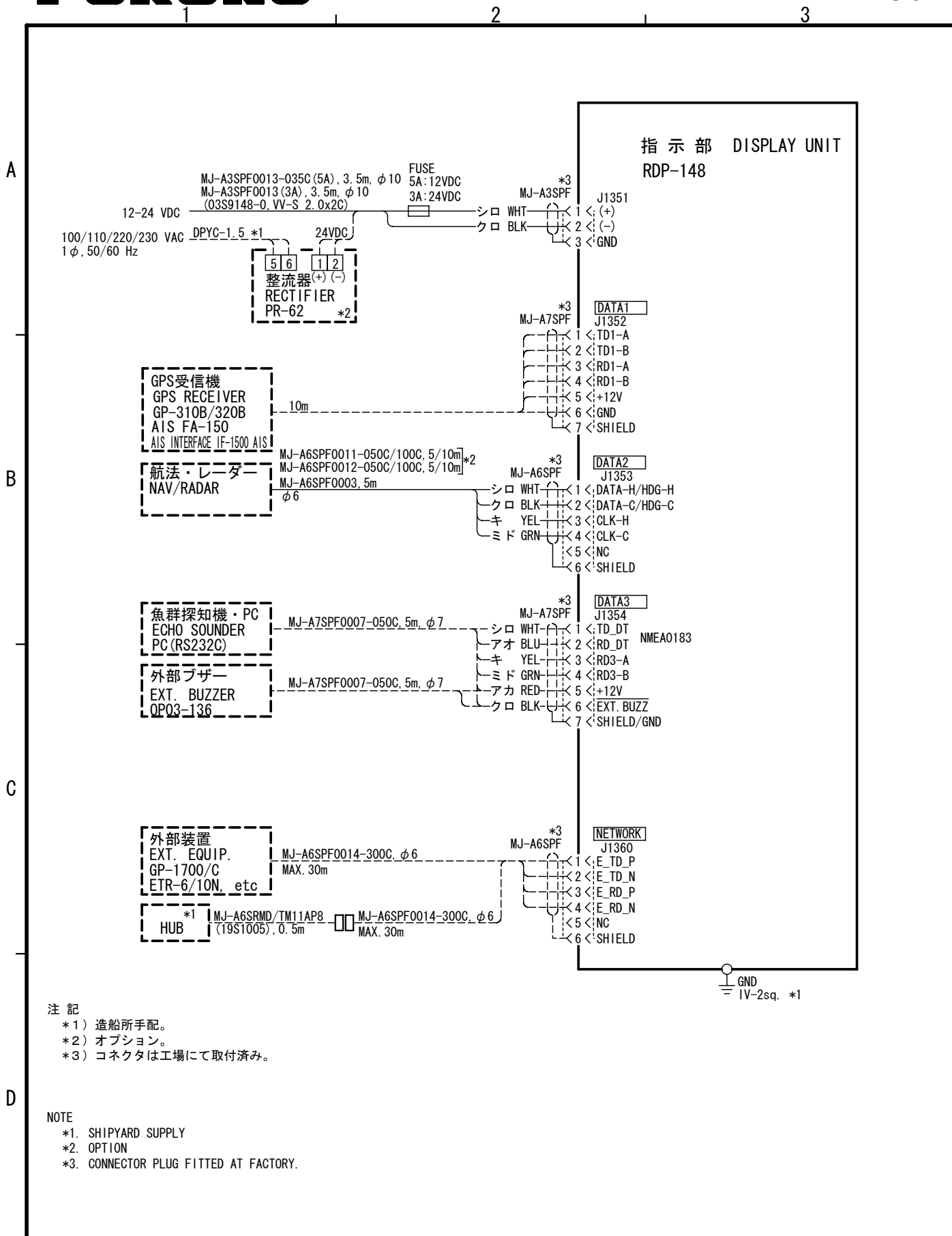

DRAWN Feb 28, '06 E. MIYOSHI	TITLE GD-1720C
CHECKED TAKAHASHI, T	名称 ビデオプロッタ
APPROVED Y. Hatai	相互結線図
SCALE MASS ±10% kg	NAME VIDEO PLOTTER
DWG. No. C4434-C01-C	INTERCONNECTION DIAGRAM