



# Packless Valves

Bellows & Diaphragm

## Index

0300 Series (Bellows)	1
4100 Series (Bellows)	4
4200 Series (Bellows)	8
4500 Series (Bellows)	11
4600 Series (Diaphragm)	13
DV1 Series (Diaphragm)	17



*packless valves*



# 0300 Series

Air Operated Bellows Valves

## Introduction

The 0300 Series valve is designed for applications where critical leak-tight integrity and cleanliness are required. The valve can be used for both automatic or remote operation. Both normally opened (NO) and normally closed (NC) air operators are available.



## Typical Applications

- High purity/hazardous gas distribution systems
- Diffusion furnaces
- Epitaxial reactors
- Gas panels
- Purge systems
- Gas cabinets

## Features & Benefits

- Operates with low air pressure and volume
- Low dead space
- Reliable shut-off
- Long cycle life insures years of maintenance free operation
- Compact design saves space in panels
- Reliable PCTFE seat increases valve life
- Normally closed (NC) or normally opened (NO) models use the same air entry position
- Special High Tolerance NPT Thread

## Technical Data

	0361 SERIES (N/C)	0371 SERIES (N/O)
MAXIMUM OPERATING PRESSURE	vacuum to 200 psig	vacuum to 350 psig
TEMPERATURE RANGE	-40° F to +250° F (-40° C to +121° C)	
ORIFICE SIZE	0.170" (4.32 mm)	
Cv FACTOR	0.28	
INTERNAL VOLUME	0.08	
HELIUM LEAK TEST - ENVELOPE MAX.	0.0005 MCFH 5.2 x 10 <sup>-9</sup> SCC/SEC	
- SEAT MAX.	0.001 MCFH 1.04 x 10 <sup>-8</sup> SCC/SEC	
BASIC MATERIAL	316 stainless steel	

### HOKE Inc.

PO Box 4866 • Spartanburg, SC 29305-4866  
 Phone (864) 574-7966 Fax (864) 587-5608  
 www.hoke.com • Sales-hoke@circor.com

packless valves

# 0300 Series

## Materials of Construction

	DESCRIPTION	MATERIAL
1	GYROLOK® fitting	316L stainless steel
2	Stem tip (replaceable)	PCTFE
3	Gasket (bellows to body seal)	PCTFE
4	Valve body	316 stainless steel
5	Bellows	316 stainless steel
6	Stem	316 stainless steel
7	Diaphragm	Fairprene®
8	Bonnet	anodized aluminum
9	Diaphragm plunger	303 stainless steel
10	O-ring seal	Buna-N®
11	Air operator body	anodized aluminum
12	Compression spring	music wire

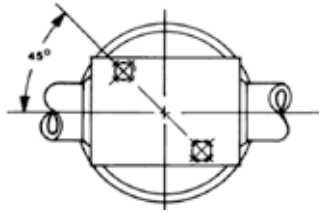

Base mounting

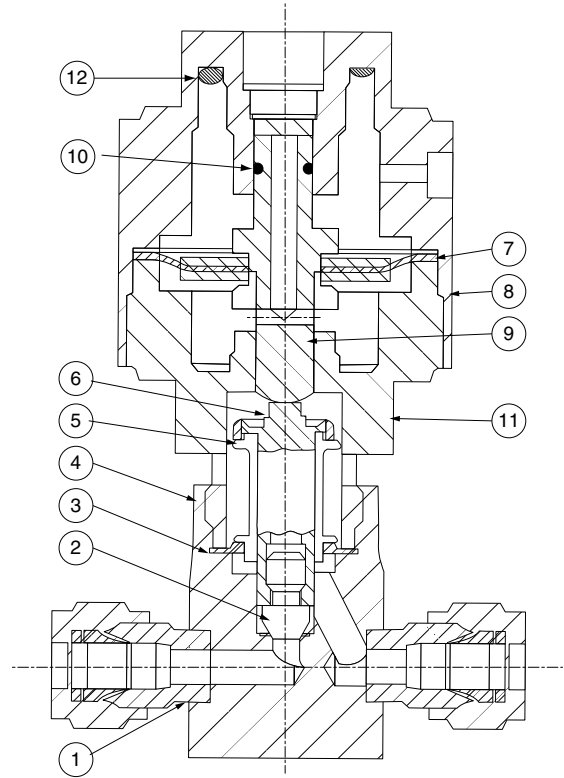

(0361G[ ]Y shown)

## Dimensions

PART NUMBER		D	E	H	R	BASE MOUNTING
0361G4Y	inch	3 ¼	½	2	1	2 mounting holes 10-32UNF-2B Thd. on 1" bolt circle
0371G4Y	mm	83	13	51	25	
0361F4Y	inch	3 ¼	½	2	1	
0371F4Y	mm	83	13	51	25	

Dimensions for reference only, subject to change.

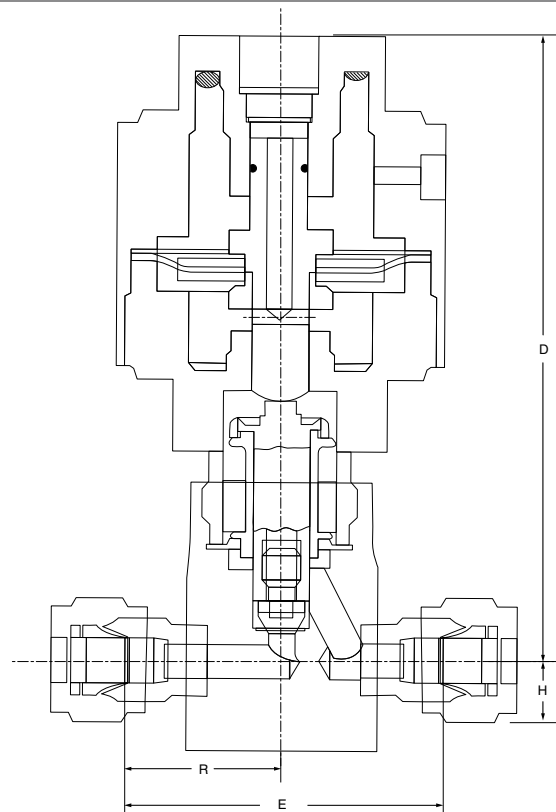

(0361G[ ]Y shown)

# 0300 Series

## Air Operated Pressure vs. System Cracking Pressure

In process systems where fugitive emissions to atmosphere are a concern, the 0300 Series air-operated bellows valve utilizes a gasket seal between the bellows and the valve body to aid in preventing any leakage of process fluid to the atmosphere. The following graphs represent the air operator/actuator input pressure vs. the outlet system pressure. Because the air operator/actuator pressure works against a normally closed or normally open spring pressure, the leak tight region changes in relation to the valve outlet or downstream pressure. The normally closed valves, for example, have better sealing capabilities at lower operator/actuator pressures. The normally open valves work opposite to the normally closed valves.

0361 Series – Normally Closed

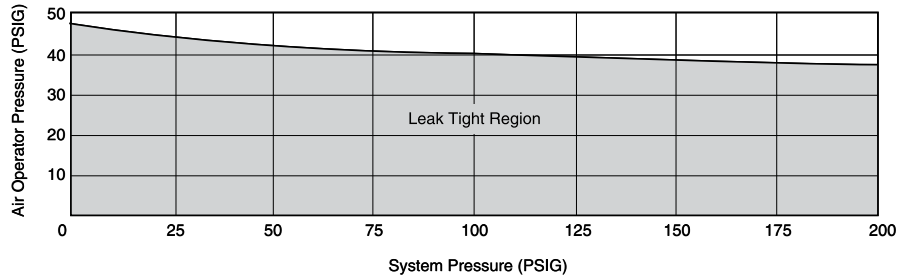

0371 Series – Normally Open

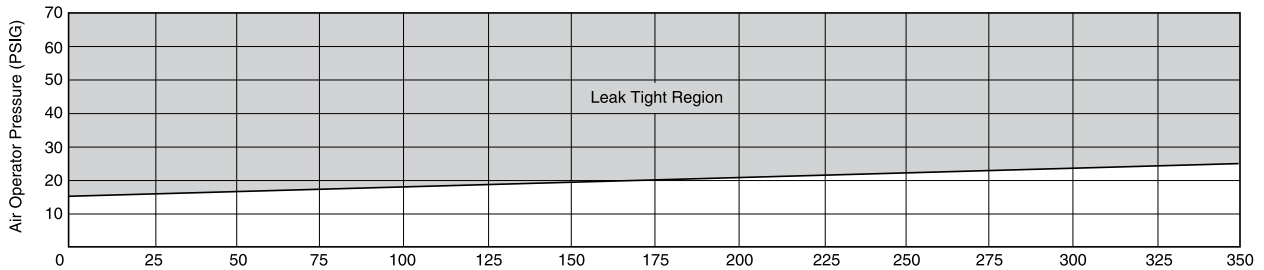

## How to Order

Order valve by part number shown in chart.

END CONNECTIONS	FLOW PATTERN	ORDER BY PART NUMBER		
		NORMALLY OPEN	NORMALLY CLOSED	ORIFICE
¼" GYROLOK®	Straight	0371G4Y	0361G4Y	0.170
¼" Female NPT	Straight	0371F4Y	0361F4Y	0.170

### FOR YOUR SAFETY

IT IS SOLELY THE RESPONSIBILITY OF THE SYSTEM DESIGNER AND USER TO SELECT PRODUCTS SUITABLE FOR THEIR SPECIFIC APPLICATION REQUIREMENTS AND TO ENSURE PROPER INSTALLATION, OPERATION AND MAINTENANCE OF THESE PRODUCTS. MATERIAL COMPATIBILITY, PRODUCT RATINGS AND APPLICATION DETAILS SHOULD BE CONSIDERED IN THE SELECTION. IMPROPER SELECTION OR USE OF PRODUCTS DESCRIBED HEREIN CAN CAUSE PERSONAL INJURY OR PROPERTY DAMAGE.



# 4100 Series

316 Stainless Steel or Brass Bellows Sealed Valves  
(.060"/1.5 mm or .170"/4.3 mm orifices)

## Introduction

With its compact size suitable for confined spaces, the 4100 Series design includes an internal volume of only 0.08 cubic inches. Brass and 316 stainless steel bodies are available. Operating pressures range from 0 - 600 psig (brass) and 0-1000 psig (stainless steel). 316 stainless steel operating temperature ratings range from -40° to +600° F (-40° to +316° C), while the brass operating temperature range is -40° to +300° F (-40° to +149° C) depending on whether a hard or soft seat is selected.

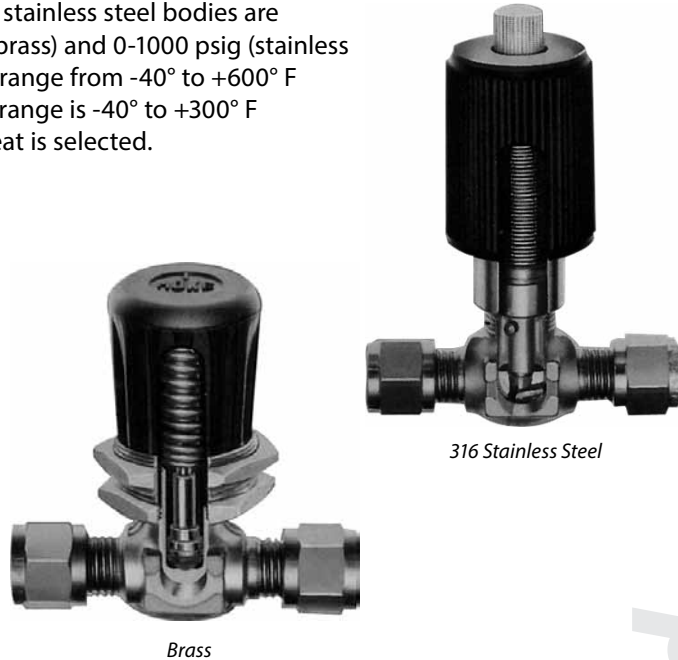

## Typical Applications

### Stainless steel valves

- Critical gas analysis
- High temperature liquid metals
- Handling reactive and toxic fluids
- Vacuum system bake-out

### Brass valves

- Sampling systems
- Gas analysis equipment
- Laboratory service
- Instrumentation

## Features & Benefits

- Low internal volume for gas analysis
- Panel mounting is available (specify kit 4100K1)

### Stainless steel valves

- Choice of blunt or regulating stem points
- Seal welded bellows to body

### Brass valves

- Phosphor bronze bellows silver-soldered to body and stem isolates fluid from atmosphere
- Choice of vee stem with small orifice for metering, blunt point, or PCTFE stem
- Special High Tolerance NPT Thread

## Technical Data

	316 STAINLESS STEEL	BRASS
<b>MAXIMUM OPERATING PRESSURE</b>	Vacuum to 1000 psig (70 kg/cm <sup>2</sup> )	Vacuum to 600 psig @ 70° F (45 kg/cm <sup>2</sup> @ 21° C)
<b>TEMPERATURE RANGE</b>	-40° F to +600° F (-40° C to +316° C)	Hard seat: -40° F to +300° F (-40° C to +149° C) Soft seat: -40° F to +250° F (-40° C to +121° C)
<b>ORIFICE SIZE</b>	Vee stem: 0.059 (1.5 mm) Blunt stem: 0.170 (4.3 mm)	Vee stem: 0.060 (1.5 mm) Blunt stem: 0.170 (4.3 mm) PCTFE stem: 0.170 (4.3 mm)
<b>Cv FACTOR</b>	0.35 (maximum)	0.35 (maximum)
<b>INTERNAL VOLUME</b>	0.08 cubic inches	0.08 cubic inches

## HOKE Inc.

PO Box 4866 • Spartanburg, SC 29305-4866  
Phone (864) 574-7966 Fax (864) 587-5608  
www.hoke.com • Sales-hoke@circor.com

packless valves

# 4100 Series

## Materials of Construction

### 316 Stainless Steel

	DESCRIPTION	MATERIAL
1	Body	316 stainless steel
2	Cap nut	Brass, nickel-plated
3	Handle	Brass, nickel-plated
4	Bellows	316 stainless steel
5	Stem point	316 stainless steel
6	Panel mounting kit	Brass, nickel-plated

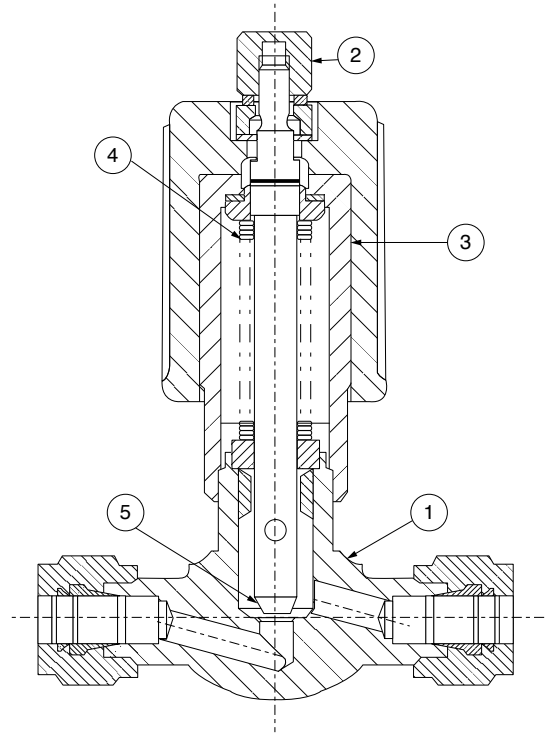

## Materials of Construction

### Brass

	DESCRIPTION	MATERIAL
1	Body	Forged brass
2	Bellows	Phosphor bronze silver-soldered to body
3	Stem	316 stainless steel
4	Stem tip	PCTFE
5	Handle	Nylon with brass insert

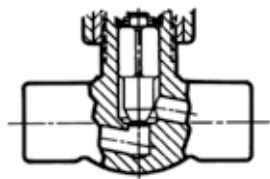

Blunt Stem  
4111M4B

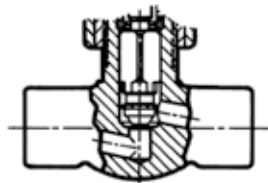

PCTFE Stem  
4151M4B

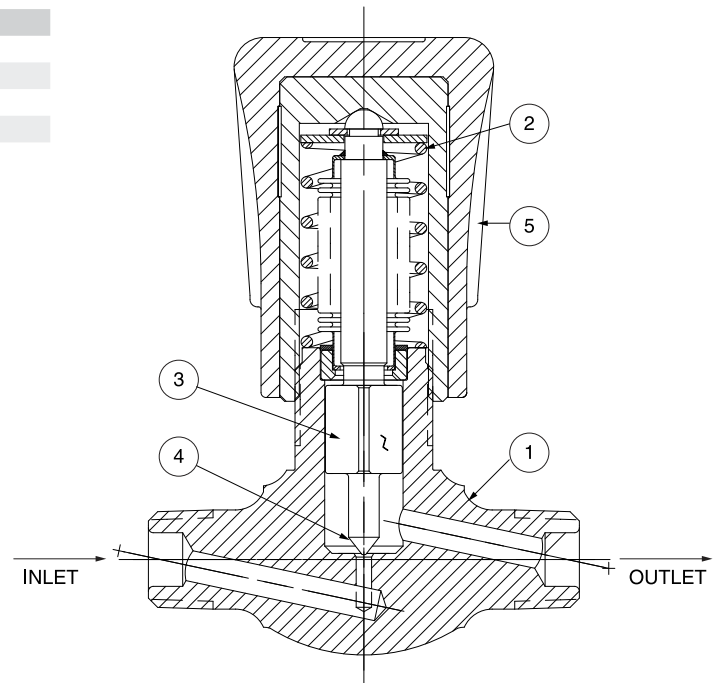

Vee Stem  
4171M4B

# 4100 Series

## Dimensions

### Stainless Steel

CONNECTIONS		D	E	F	H	H1	PANEL MOUNTING	
							HOLE SIZE	MAX. THICKNESS
¼" NPT Male	inch	3	1 ¾	1	2 <sup>5</sup> / <sub>4</sub>	1 <sup>1</sup> / <sub>2</sub>	1 ¼	¼
	mm	76	44	25	10	9	26	6
¼" O.D. Tube GYROLOK®	inch	3	2 ¾	1	2 <sup>5</sup> / <sub>4</sub>	1 <sup>1</sup> / <sub>2</sub>	1 ¼	¼
	mm	76	60	25	10	9	26	6
6 mm GYROLOK®	inch	3	2 ¾	1	2 <sup>5</sup> / <sub>4</sub>	1 <sup>1</sup> / <sub>2</sub>	1 ¼	¼
	mm	76	60	25	10	9	26	6

Dimensions for reference only, subject to change.

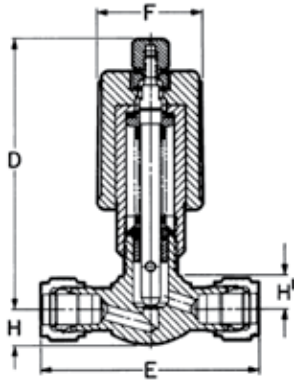

Blunt Stem  
4112G4Y

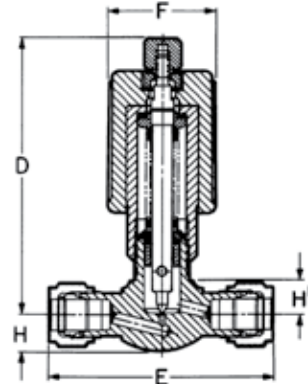

Vee Stem  
4172G4Y

## Dimensions

### Brass

CONNECTIONS		D	E	F	H	H1	PANEL MOUNTING	
							HOLE SIZE	MAX. THICKNESS
⅛" NPT Male	inch	2 ⅝	1 ¾	1 ¼	2 <sup>3</sup> / <sub>4</sub>	¾	1 ¼	¼
	mm	67	44	27	9	10	26	6
¼" NPT Male	inch	2 ⅝	1 ¾	1 ¼	2 <sup>3</sup> / <sub>4</sub>	¾	1 ¼	¼
	mm	67	44	27	9	10	26	6
¼" O.D. Tube GYROLOK®	inch	2 ⅝	1 ¾	1 ¼	2 <sup>3</sup> / <sub>4</sub>	¾	1 ¼	¼
	mm	67	60	27	9	10	26	6

Dimensions for reference only, subject to change.

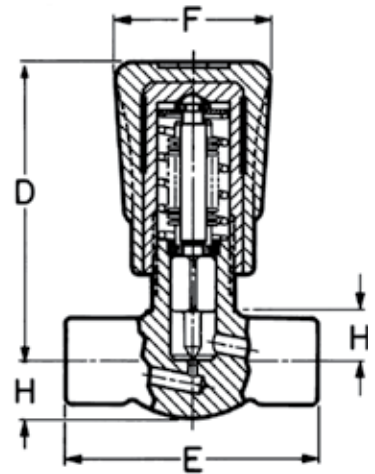

Vee Stem  
4171M4B

# 4100 Series

## How to Order

**Stainless Steel:** Order valve by part number shown in chart.

CONNECTIONS	ORDER BY PART NUMBER			
	BLUNT STEM	VEE STEM	CV FACTOR	ORIFICE
¼" NPT Male	4112M4Y	—	0.35	0.17
¼" O.D. Tube <b>GYROLOK</b> ®	—	4172G4Y	0.059	0.06
¼" O.D. Tube <b>GYROLOK</b> ®	4112G4Y	—	0.35	0.17
6 mm <b>GYROLOK</b> ®	4112G6Y/MM	—	0.35	0.17
6 mm <b>GYROLOK</b> ®	—	4172G6Y/MM	0.059	0.06
Panel Mounting Kit	4100K1	4100K1	—	—

**Brass:** Order valve by part number shown in chart.

CONNECTIONS	ORDER BY PART NUMBER				CV FACTOR	ORIFICE
	BLUNT STEM	VEE STEM	PCTFE STEM			
½" NPT Male	4111M2B	—	4151M2B	—	0.35	0.17
½" NPT Male	—	4171M2B	—	—	0.059	0.06
¼" NPT Male x ¼" NPT Female	4111L2B	—	—	—	0.35	0.17
¼" NPT Male	4111M4B	—	4151M4B	—	0.35	0.17
¼" NPT Male	—	4171M4B	—	—	0.059	0.06
¼" O.D. Tube <b>GYROLOK</b> ®	—	—	4151G4B	—	0.35	0.17

## Panel Mounting

To order Panel Mounting Kit, specify part number 4100K1.

### FOR YOUR SAFETY

IT IS SOLELY THE RESPONSIBILITY OF THE SYSTEM DESIGNER AND USER TO SELECT PRODUCTS SUITABLE FOR THEIR SPECIFIC APPLICATION REQUIREMENTS AND TO ENSURE PROPER INSTALLATION, OPERATION AND MAINTENANCE OF THESE PRODUCTS. MATERIAL COMPATIBILITY, PRODUCT RATINGS AND APPLICATION DETAILS SHOULD BE CONSIDERED IN THE SELECTION. IMPROPER SELECTION OR USE OF PRODUCTS DESCRIBED HEREIN CAN CAUSE PERSONAL INJURY OR PROPERTY DAMAGE.





# 4200 Series

316 Stainless Steel Bellows Sealed Valves  
(0.156"/3.962 mm orifice)

## Introduction

With its wide operating temperature range of -320° to 1200° F (-196° to +649° C), the 4200 Series meets the demands of many critical fluid control conditions. Operating pressure range is 0-2000 psig. Applications include high temperature liquid metals, cryogenic service, and gas analysis.



## Typical Applications

- Critical gas analysis
- High temperature liquid metals
- Cryogenics
- Reactive and toxic fluids
- Sealing cesium or isotope containers
- High vacuum systems

## Technical Data

<b>MAXIMUM OPERATING PRESSURE</b>	Hard seats: 2000 psi @ 600° F (141 kg/cm <sup>2</sup> @ 316° C) Soft seats: 500 psi @ 350° F (35 kg/cm <sup>2</sup> @ 175° C)
<b>HIGH VACUUM</b>	to 10 <sup>-5</sup> Torr
<b>TEMPERATURE RANGE</b>	-320° F to +1200° F (-195° C to +632° C)
<b>ORIFICE SIZE</b>	0.156 (3.962 mm)
<b>Cv FACTOR</b>	0.36 (maximum)
<b>INTERNAL VOLUME</b>	0.18 cubic inches

## Features & Benefits

- Positive plug return on all valves prevents plug sticking in severe service
- No torque transmitted to bellows – Hex guide mates with hex broach in bonnet
- Secondary o-ring seal in upper bonnet prevents leakage if bellows is damaged
- Non-rising stem prevents galling or seizing of stem threads
- Heavy-duty welded bellows provides long cycle life and assures leak tight service. Long size bellows insures full lift and utilization of full orifice area.
- All-welded design for high-temperature and high-pressure service
- Plugs and bellows are replaceable on all gasketed types
- Valves can be base or panel mounted – add prefix “D” to part number for panel mounted
- Variety of materials and modifications
- Special High Tolerance NPT Thread

packless valves

## HOKE Inc.

PO Box 4866 • Spartanburg, SC 29305-4866  
Phone (864) 574-7966 Fax (864) 587-5608  
www.hoke.com • Sales-hoke@circor.com

# 4200 Series

## Materials of Construction

DESCRIPTION	4251F2Y 4251F4Y 4251N6Y 4251G4Y	4212F4Y	4235Q6Y	4213Q6Y
	1 Body, bar stock	316 stainless steel	316 stainless steel	316 stainless steel
2 Bellows assembly	316 stainless steel	316 stainless steel	316 stainless steel	316 stainless steel
3 Seal, bellows-to-body	PTFE	316 stainless steel	316 stainless steel seal welded	316 stainless steel seal welded
4 Disc or plug	PTFE	316 stainless steel	316 stainless steel stellite	316 stainless steel
5 Packing, secondary	O-ring seal	O-ring seal	Garlock® 908	O-ring seal
6 Bonnet	aluminum	303 stainless steel	303 stainless steel	303 stainless steel
7 Handle	Nylon wheel	aluminum cross, die cast	303 stainless steel	aluminum cross, die cast

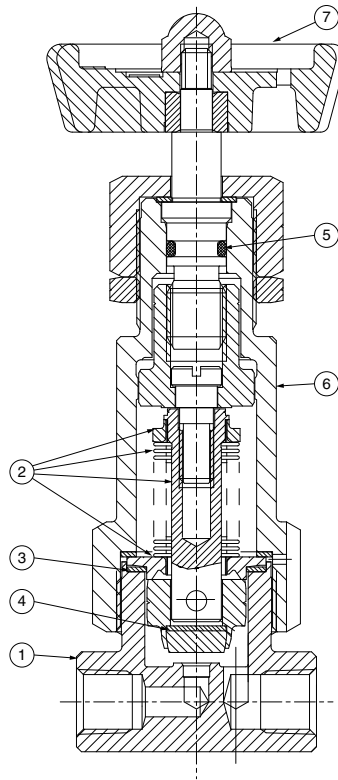

## Dimensions

CONNECTIONS	D (OPEN)	E	F	H	H'	PANEL MOUNTING		BASE MOUNTING
						HOLE SIZE	MAX. THICKNESS	
4212F4Y	inch	4 7/16	1 1/2	2 3/8	1 3/32	2 3/8	2 3/32	3/16
	mm	113	38	60	10	60	20	5
4251F4Y	inch	4 7/16	1 1/2	1 13/16	1 3/32	2 9/32	2 5/32	3/16
	mm	113	38	46	10	58	20	5
4251G4Y	inch	4 5/8	2 5/32	1 13/16	1 15/32	2 1/32	2 5/32	3/16
	mm	117	55	46	12	64	20	5
4213Q6Y	inch	4 3/8	7 1/2	2 3/8	5/16	2 9/32	2 5/32	3/16
	mm	111	191	60	8	58	20	5
4235Q6Y	inch	6 1/2	7 1/2	2 3/8	5/16	2 9/32	2 5/32	3/16
	mm	165	191	67	8	58	20	5
4212G4Y	inch	4 5/8	2 5/32	1 13/16	1 15/32	2 7/32	2 5/32	3/16
	mm	117	55	46	12	64	20	5

2 mounting  
holes 10-32  
NF Thd.,  
0.187 min. full  
thd.

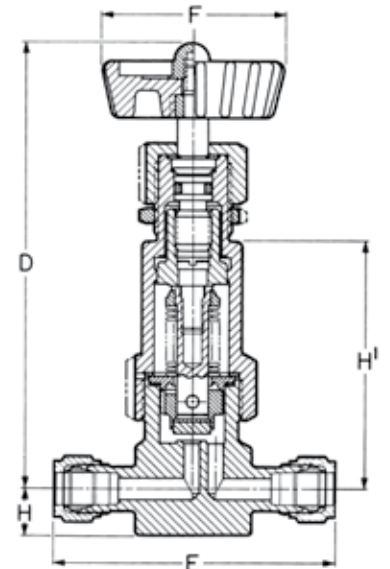

Dimensions for reference only, subject to change.

# 4200 Series

## How to Order

Order valve by part number shown in chart.

	CONNECTIONS INLET & OUTLET	ORDER BY PART NUMBER	CV FACTOR	OPERATING PRESSURE	TEMPERATURE RANGE
PIPE ENDED MODELS	¼" NPT Female	4212F4Y	0.33	2000 @ 600° F	-320° F to 600° F (-196° C to 316° C)
		4251F4Y	0.36	500 @ 350° F	-65° F to 350° F (18° C to 177° C)
GYROLOK®	¼" GYROLOK® tube fitting	4212G4Y	0.33	2000 @ 600° F	-320° F to 600° F (-196° C to 316° C)
		4251G4Y	0.36	500 @ 350° F	-65° F to 350° F (18° C to 177° C)
SOCKET WELD MODELS	⅜" O.D. socket weld	4212N6Y	0.33	2000 @ 600° F	-320° F to 600° F (-196° C to 316° C)
		4251N6Y	0.36	500 @ 350° F	-65° F to 350° F (18° C to 177° C)
3" TUBE EXTENSIONS SOCKET WELD TO BODY	Socket weld to body	4213Q6Y	0.33	2000 @ 600° F 400 @ 900° F	-320° F to 900° F (196° C to 482° C)
		4235Q6Y	0.33	2000 @ 600° F 250 @ 1200° F	-320° F to 1200° F (196° C to 649° C)

### FOR YOUR SAFETY

IT IS SOLELY THE RESPONSIBILITY OF THE SYSTEM DESIGNER AND USER TO SELECT PRODUCTS SUITABLE FOR THEIR SPECIFIC APPLICATION REQUIREMENTS AND TO ENSURE PROPER INSTALLATION, OPERATION AND MAINTENANCE OF THESE PRODUCTS. MATERIAL COMPATIBILITY, PRODUCT RATINGS AND APPLICATION DETAILS SHOULD BE CONSIDERED IN THE SELECTION. IMPROPER SELECTION OR USE OF PRODUCTS DESCRIBED HEREIN CAN CAUSE PERSONAL INJURY OR PROPERTY DAMAGE.



Pipe ended  
4212F4Y



3" Tube extensions  
4235Q6Y



Socket weld  
4251N6Y



## 4500 Series

Bellows Sealed Valves  
(0.156"/3.962 mm Orifice)

### Introduction

This miniature valve can be manually or remotely operated. Operating temperatures range from -20° to +250° F (-29° to +120° C), while operating pressures range from high vacuum to 300 psig. Available in brass and Monel®, this valve can be used as a stop valve in a calibrated leak tester, and in labs where leak-tight service is necessary.



### Typical Applications

- Stop valve in calibrated leak tester
- High vacuum work
- Laboratory environments demanding leak-tight service

### Technical Data

<b>MAXIMUM OPERATING PRESSURE</b>	10 <sup>-5</sup> Torr to 300 psig
<b>TEMPERATURE RANGE</b>	-20° F to +250° F (-29° C to +120° C)
<b>ORIFICE SIZE</b>	0.156 (model 4551Q6M – 0.281 orifice)
<b>Cv FACTOR</b>	0.70 maximum
<b>INTERNAL VOLUME</b>	0.08 cubic inches

### Features & Benefits

- Protective handle limits escape of process fluid if bellows ruptures
- Bellows assembly is replaced by removing cap handle and retaining nut
- PCTFE seat is fully encapsulated to prevent cold flow
- Bellows is sealed to body with a PCTFE gasket
- Bellows and stem are one-piece assembly
- Available with female NPT or silver-soldered copper tube extensions
- One of the smallest valve types and capacities available
- Air-to-open or air-to-close operators for remote actuation are available
- Valve may be base-mounted
- Special High Tolerance NPT Thread

packless valves

### HOKE Inc.

PO Box 4866 • Spartanburg, SC 29305-4866  
Phone (864) 574-7966 Fax (864) 587-5608  
www.hoke.com • Sales-hoke@circor.com

# 4500 Series

## Materials of Construction

DESCRIPTION	4551F2B 4551Q4B	4551Q4M
1 Body	Brass	Monel®
2 Bellows	Phosphor bronze	Phosphor bronze
3 Bellows-to-body seal	PCTFE	PCTFE
4 Stem	Monel®	Monel®
5 Plug disc	PCTFE	PCTFE
6 Bellows retaining nut	Brass	Brass
7 Cap	Brass, nickle-plated	Brass, nickle-plated
8 Tube extension	Copper	Copper

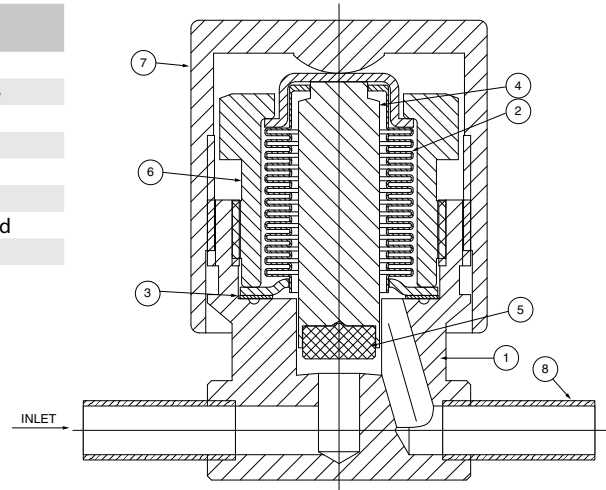

## Dimensions

CONNECTIONS	FLOW PATTERN		D	E	F	G	H
1/8" NPT Female	Straight	inch	1 29/32"	1 1/4"	1 1/4"	1 1/8"	19/64"
		mm	48	32	32	29	8
1/4" O.D Tube Extensions	Straight	inch	1 29/32"	1 1/4"	6 13/16"	1 1/8"	3/16"
		mm	48	32	173	29	5
1/4" O.D Tube Extensions	Angle	inch	1 29/32"	1 1/4"	3 13/32"	1 1/8"	3/16"
		mm	48	32	87	29	5
1/4" O.D Tube Extensions	Tee	inch	1 29/32"	1 1/4"	6 13/16"	1 1/8"	3/16"
		mm	48	32	173	29	5
3/8" O.D Tube Extensions	Straight	inch	3 13/32"	1 1/4"	9 1/4"	1 1/8"	3/16"
		mm	87	32	235	29	5

### BASE MOUNTING

2 mounting holes on 3/4" dia.  
8-32UNC-2B  
3/16"  
minimum full thread

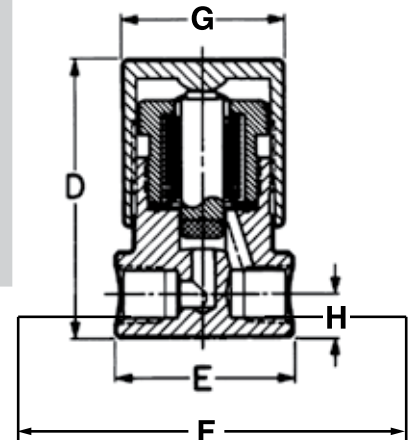

(For tube extensions only)

Dimensions for reference only, subject to change.

\* Straight flow pattern view shown.

## How to Order

CONNECTIONS	FLOW PATTERN	ORDER BY PART NUMBER		
		BRASS	MONEL®	Cv
1/8" NPT Female	Straight	4551F2B	—	0.21
1/4" O.D. Tube Extensions	Straight	—	4551Q4M	0.21
1/4" O.D. Tube Extensions	Straight	4551Q4B	—	0.21

### FOR YOUR SAFETY

IT IS SOLELY THE RESPONSIBILITY OF THE SYSTEM DESIGNER AND USER TO SELECT PRODUCTS SUITABLE FOR THEIR SPECIFIC APPLICATION REQUIREMENTS AND TO ENSURE PROPER INSTALLATION, OPERATION AND MAINTENANCE OF THESE PRODUCTS. MATERIAL COMPATIBILITY, PRODUCT RATINGS AND APPLICATION DETAILS SHOULD BE CONSIDERED IN THE SELECTION. IMPROPER SELECTION OR USE OF PRODUCTS DESCRIBED HEREIN CAN CAUSE PERSONAL INJURY OR PROPERTY DAMAGE.



Straight Pattern  
4551F2B



# 4600 Series

## Gasketed & Welded Diaphragm Valves

### Introduction

Available in gasketed and welded versions, this valve offers a Cv of 0.2. Operating temperature range of the welded construction version is -65° to +600° F (-54° to +316° C), permitting it to be used for high temperature bake-out. The gasketed version can be used in high vacuums, corrosive fluids, and gas analysis.

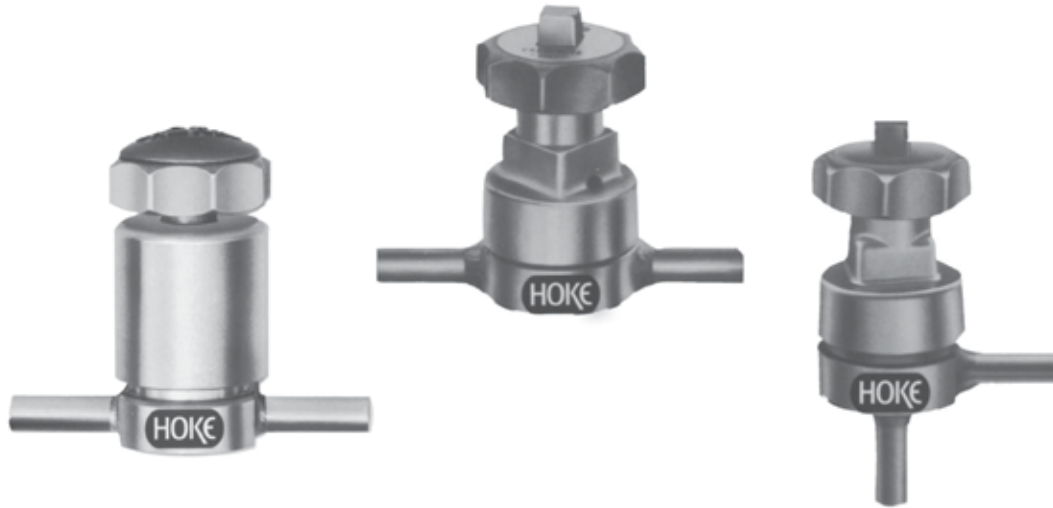

### Typical Applications

- High temperature bake-out
- High vacuum
- Instrumentation
- Research labs
- Gas analysis
- Corrosive fluids

### Features & Benefits

- Monel® construction
- Diaphragm provides low internal volume and low dead space
- ¼" socket weld tube extensions
- All welded models may be used for bake-out temperatures to 600° F (316° C) – plastic handle cap must be removed
- Select from globe or angle flow patterns
- Compact size
- All models can be base mounted

### Gasketed Valves

- Square drive on handle permits reach rod operation for remote areas
- Easy replacement of diaphragm assembly
- Special High Tolerance NPT Thread

### Technical Data

	GASKETED	WELDED
<b>MAXIMUM OPERATING PRESSURE</b>	300 psig @ 70° F (2.07 MPa @ 21° C)	vacuum to 300 psig @ 70° F
<b>VACUUM</b>	10 <sup>-5</sup> Torr	—
<b>TEMPERATURE RANGE</b>	-65° F to +240° F (-54° C to +116° C)	-65° F to +600° F (-54° C to +316° C)
<b>ORIFICE SIZE</b>	0.125 (3.2 mm)	0.125 (3.2 mm)
<b>Cv FACTOR</b>	0.2	0.2
<b>INTERNAL VOLUME</b>	0.11 cubic inches	0.11 cubic inches
<b>HELIUM LEAK TEST - ENVELOPE MAX.</b>	5 x 10 <sup>-9</sup> SCC/SEC	5 x 10 <sup>-9</sup> SCC/SEC
<b>- SEAT MAX.</b>	1 x 10 <sup>-8</sup> SCC/SEC	1 x 10 <sup>-8</sup> SCC/SEC

### HOKE Inc.

PO Box 4866 • Spartanburg, SC 29305-4866  
 Phone (864) 574-7966 Fax (864) 587-5608  
 www.hoke.com • Sales-hoke@circor.com

packless valves

# 4600 Series

## Materials of Construction

### Gasketed

	DESCRIPTION	MONEL®
1	Body	Monel®
2	Tube extensions	Monel®
3	Diaphragm	Inconel®
4	Stem point	Monel® K-500
5	Stem	316 stainless steel
6	Compression spring	Music wire
7	Housing	Brass, nickle-plated
8	Handle	Ni silver
9	Gasket	Aluminum

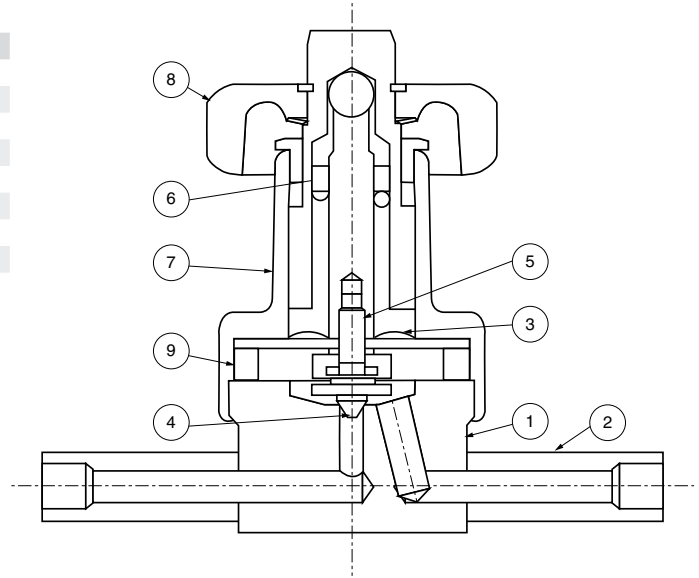

## Materials of Construction

### Welded

	DESCRIPTION	MONEL®
1	Body	Monel®
2	Diaphragm	Inconel®
3	Stem point	Monel® K-500
4	Diaphragm ring	Monel®
5	Diaphragm clamp	316 stainless steel
6	Stem	316 stainless steel
7	Compression spring	Music wire
8	Housing	316 stainless steel
9	Handle	Ni silver

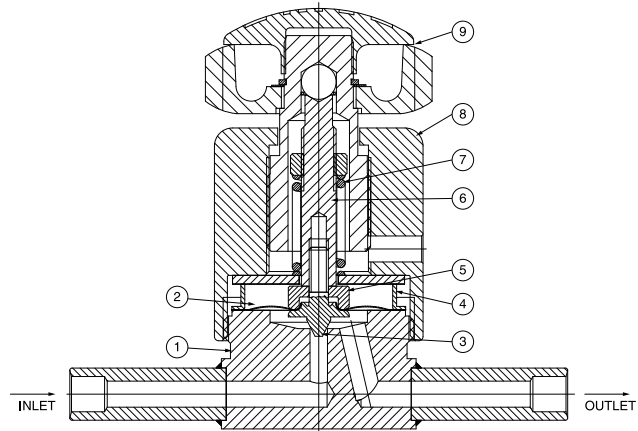

This tube union is designed for use with all 4600 Series valves in high vacuum applications. The gland end may be connected to tubing or block with 1/4" O. D. The seat end will fit tubing or a projection of 3/8" O. D. (To order, specify part number 62076.)

DESCRIPTION	MATERIAL
Seat end	Monel®
Gland	Monel®
Male Nut	aluminum bronze

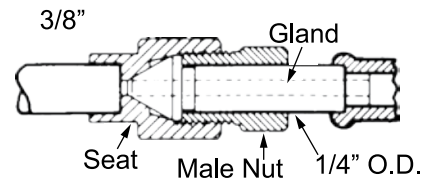

# 4600 Series

## Dimensions

### Gasketed

PART NUMBER		D	E	F	H	BASE MOUNTING
4613N4M	inch	2 5/8	3 1/2	1 5/8	1/4	2 holes on 1" dia. 1/4-20 NC Thd. Full thd. 3/8" deep
	mm	66	89	41	6	
4623N4M	inch	2 5/8	1 3/4	1 5/8	1/4	
	mm	66	44	41	6	

Dimensions for reference only, subject to change.

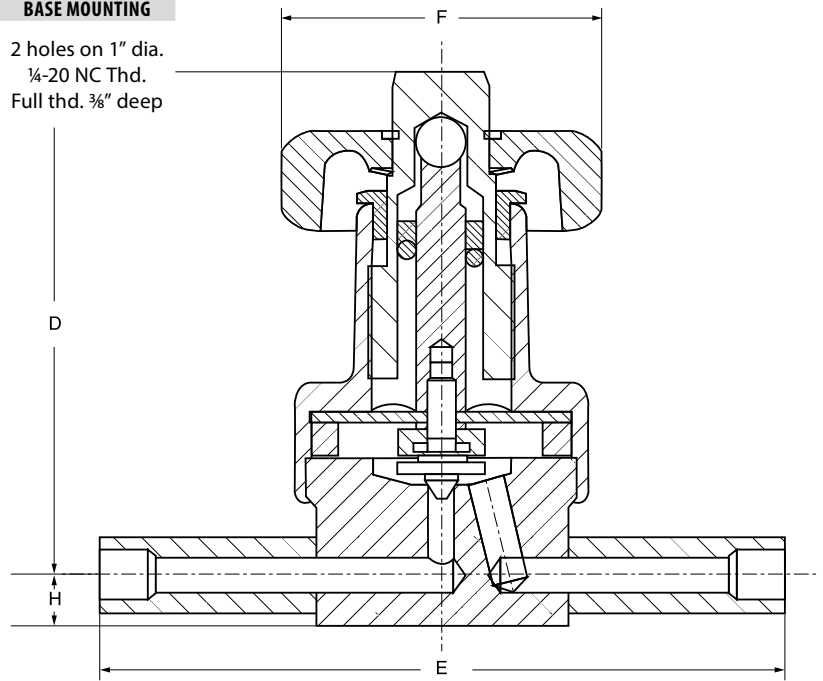

Straight flow pattern

## Dimensions

### Welded

CONNECTIONS	FLOW PATTERN		D	E	F	H	BASE MOUNTING
1/4" O.D. tube	Angle	inch	2 13/16	1 3/4	1 5/8	1/4	2 holes on 1" dia. 1/4-20 NC Thd. Full thd. 3/8" deep
		mm	71	44	41	6	
1/4" O.D. tube	Straight	inch	2 13/16	3 1/2	1 5/8	1/4	
		mm	71	89	41	6	

Dimensions for reference only, subject to change.

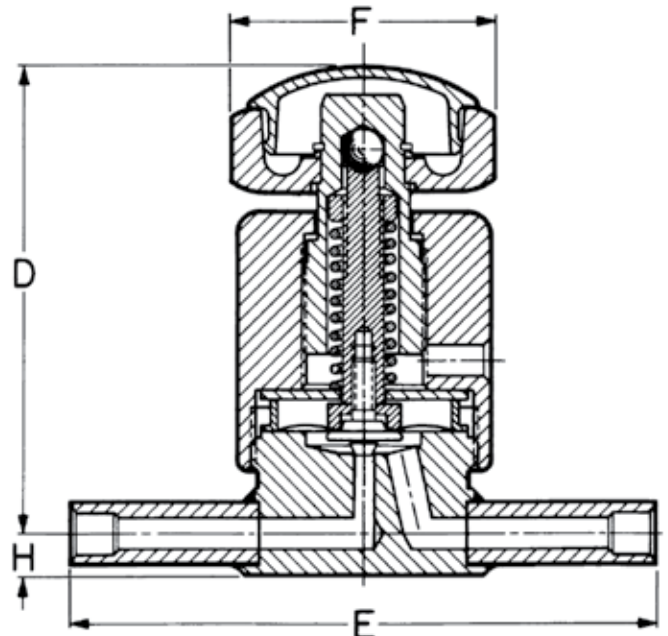

Straight flow pattern



# 4600 Series

## How to Order

Order valve by part number shown in chart.

	CONNECTIONS	FLOW PATTERN	ORDER BY PART NUMBER
			MONEL®
GASKETED	¼" Tube extensions	Straight	4613N4M
	¼" Tube extensions	Angle	4623N4M
WELDED	¼" Socket weld tube extensions	Straight	4618N4M
	¼" Socket weld tube extensions	Angle	4628N4M

## For Your Safety

It is solely the responsibility of the system designer and user to select products suitable for their specific application requirements and to ensure proper installation, operation, and maintenance of these products. Material compatibility, product ratings and application details should be considered in the selection. Improper selection or use of products described herein can cause personal injury or property damage.

*Garlock® is a registered trademark of Coltec North Carolina Inc.*

*GYROLOK® is a registered trademark of HOKE Incorporated*

*Monel® and Inconel® are registered trademarks of Special Metals Corporation*

*Fairprene® is a registered trademark of DuPont*

*[www.goodrich.com](http://www.goodrich.com)*

*[www.hoke.com](http://www.hoke.com)*

*[www.specialmetals.com](http://www.specialmetals.com)*

*[www.dupontelastomers.com](http://www.dupontelastomers.com)*



## DV1 Series

### 2-Way Diaphragm Valves

The DV1 Series Diaphragm Valves are totally free of springs, bellows, packing, o-rings and lubricants in the process wetted area. Metal-to-metal seals to atmosphere ensure that there is no transport of undesirable elements into the flow stream, and no escaping of process material into the atmosphere. Elgiloy® diaphragms ensure the utmost in corrosion resistance and extend overall valve life.



diaphragm valves

#### Typical Applications

- Analytical Instrumentation
- Petrochemical
- Pharmaceutical
- Chemical

#### Features & Benefits

- 2-way on/off control
- Metal-to-metal seals to atmosphere to prevent leakage
- Wide variety of materials for virtually all applications
- No dynamic O-rings, springs, or lubricant in wetted flow path to eliminate sample contamination
- Very low internal volume (0.16 cc)\*
- Manual ¼-plus turn or pneumatic actuation
- Pressures from vacuum (50 torr) to 3600 psig (248 bar)\*\*
- 40µ sintered stainless steel air inlet filter extends life of pneumatic actuator

\* Internal volume in machined passages of the valve body between mounting surface and sealing diaphragm(s).

\*\* Valves cleaned for oxygen service are limited to 3000 psig (207 bar).

#### HOKE Inc.

PO Box 4866 • Spartanburg, SC 29305-4866  
Phone (864) 574-7966 Fax (864) 587-5608  
www.hoke.com • Sales-hoke@circor.com

# DV1 Series

## Manual 1/4-plus Turn Valves



### Technical Data

<b>BODY</b>	316L stainless steel, Monel® and Hastelloy® C-276
<b>SEATS</b>	PCTFE and PEEK™
<b>DIAPHRAGMS</b>	Elgiloy® AMS 5876
<b>ORIFICE SIZE</b>	0.110" (2.8 mm)
<b>FLOW CAPACITY</b>	0.17 Cv
<b>VALVE INTERNAL VOLUME*</b>	0.16 cc
<b>LEAKAGE</b>	1 × 10 <sup>-9</sup> cc/sec helium (inboard)

\* Internal volume in machined passages of the valve body between mounting surface and sealing diaphragm(s).

### Operating Pressures

<b>OPERATING PRESSURE*</b>	Vacuum (50 torr) to 3600 psig (248 bar)
<b>PROOF PRESSURE</b>	7200 psig
<b>BURST PRESSURE</b>	14,400 psig (497 barg)

\* Valves cleaned for oxygen service are limited to 3000 psig (207 bar).

### Operating Temperatures

SEAT MATERIAL	1/4-PLUS TURN TEMPERATURE
PCTFE	-40° F to +212° F (-40° C to +100° C)
PEEK™	-40° F to +400° F (-40° C to +204° C)

### Pressure vs. Flow Curve

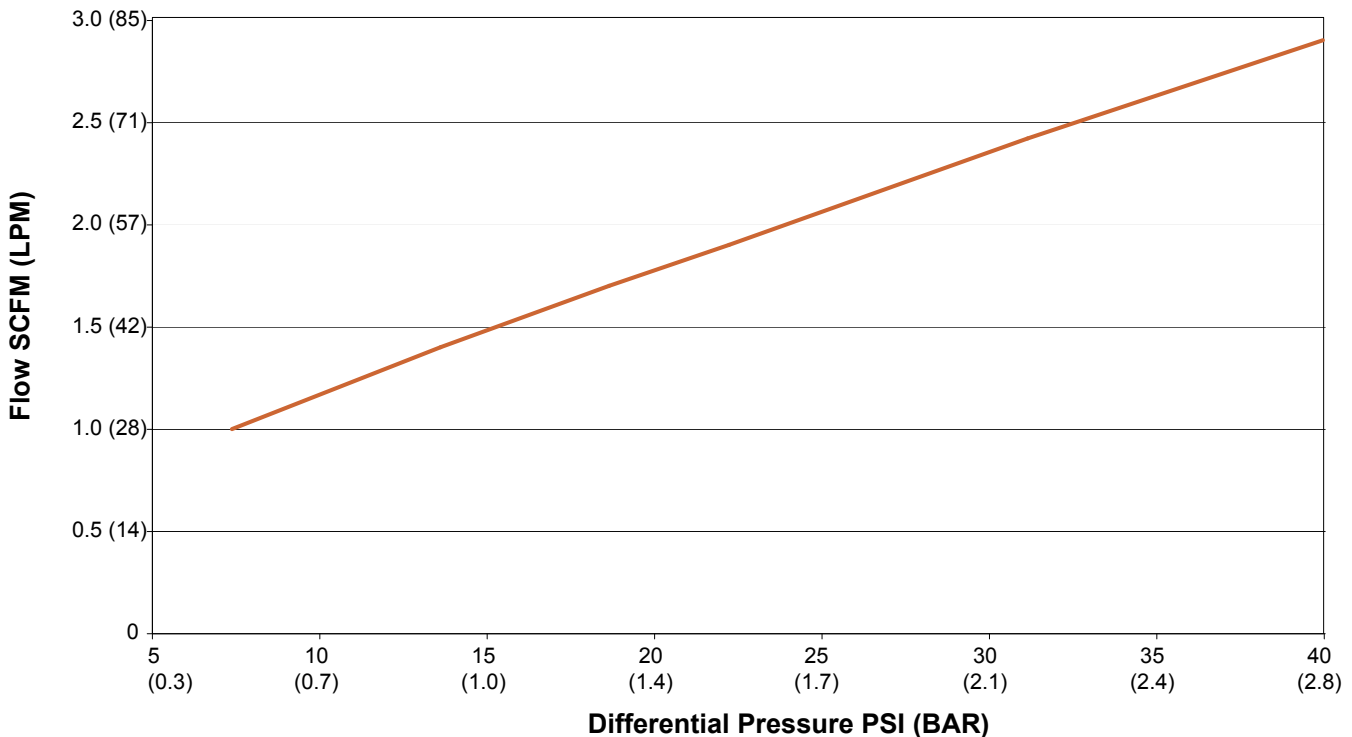

# DV1 Series

## Materials of Construction

#	PART	MATERIALS
1	Stem	17-4PH stainless steel, condition H900
2	Diaphragm*	Elgiloy® AMS 5876
3	Body*	316L stainless steel, Monel®, Hastelloy® C-276
4	Seat*	PCTFE, PEEK™
5	Handle	316 stainless steel
6	Thrust plug	Brass
7	Diaphragm retainer	316 stainless steel
8	Bonnet	316L stainless steel, Monel®, Hastelloy® C-276
9	Handle nut	18-8 stainless steel
10	Front ferrule*	316L stainless steel, Monel®, Hastelloy® C-276
11	Rear ferrule	316L stainless steel, Monel®, Hastelloy® C-276
12	Nut	316L stainless steel, Monel®, Hastelloy® C-276
13	Panel-mount nut	316L stainless steel, Monel®, Hastelloy® C-276

\*Wetted components

### Manual ¼-plus turn Valves

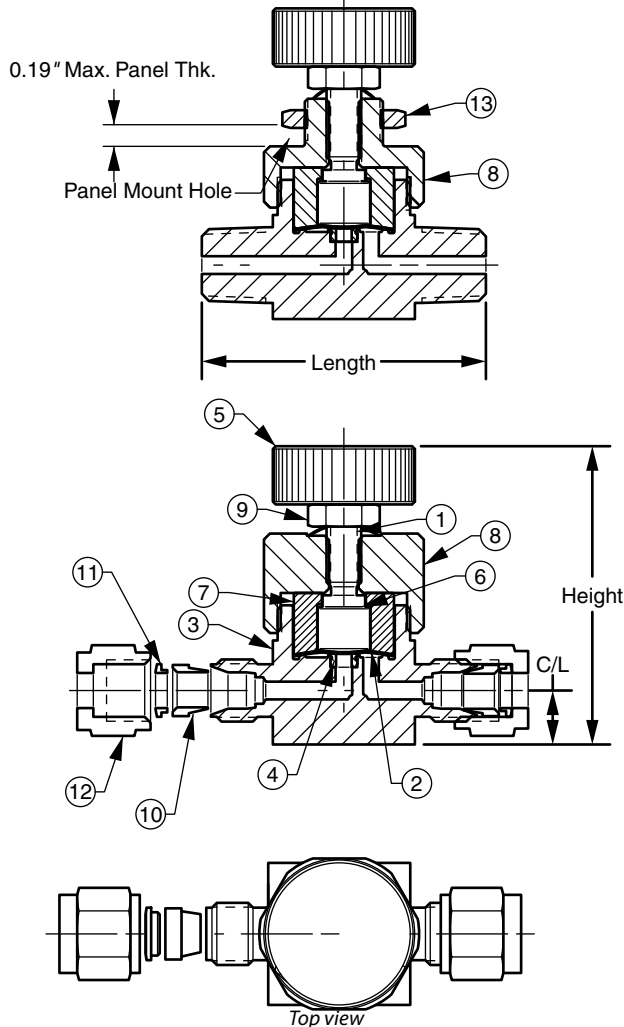

### Optional T-handle Valves

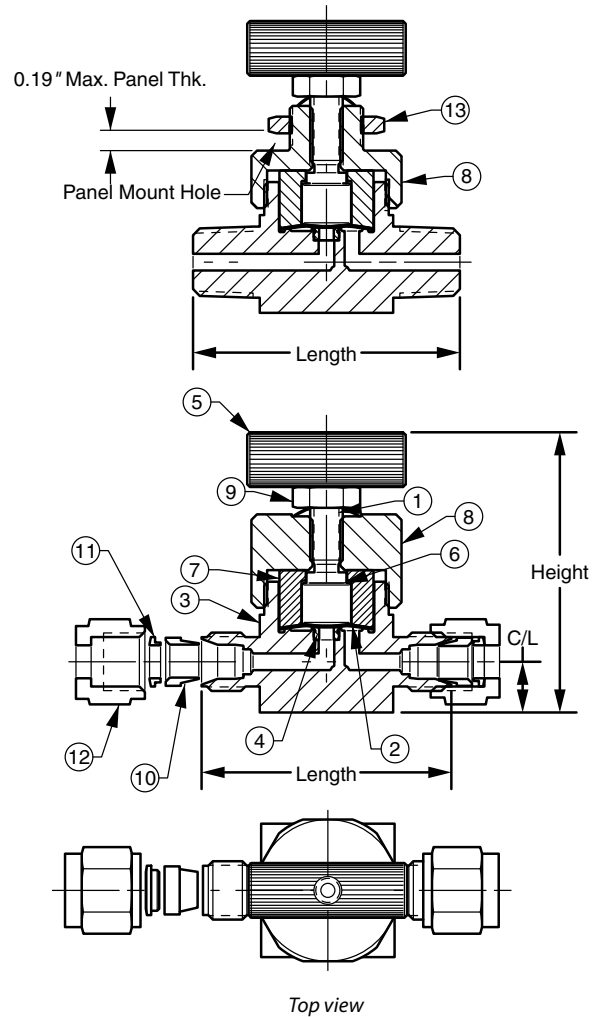

## Dimensions

### Manual ¼-plus Turn Valves

END CONNECTION	LENGTH	HEIGHT	HANDLE RADIUS	C/L CENTER LINE	PANEL MOUNT HOLE	PANEL MOUNT THICK
¼" MNPT	2.00"	2.44"	0.90"	0.38"	0.57"	0.19"
¼" FNPT	2.00"	2.44"	0.90"	0.38"	0.57"	0.19"
⅜" GYROLOK®	1.71"	2.44"	0.90"	0.38"	0.57"	0.19"
¼" GYROLOK®	1.87"	2.44"	0.90"	0.38"	0.57"	0.19"
¼" NPT extended	3.15"	2.44"	0.90"	0.38"	0.57"	0.19"
6mm GYROLOK®	47.5mm	61.98mm	22.86mm	9.65mm	14.48mm	4.83mm
8mm GYROLOK®	47.5mm	61.98mm	22.86mm	9.65mm	14.48mm	4.83mm

# DV1 Series

## Pneumatic Actuated Valves



### Technical Data

<b>BODY</b>	316L stainless steel, Monel® and Hastelloy® C-276
<b>SEATS</b>	PCTFE, PEEK™
<b>DIAPHRAGMS</b>	Elgiloy® AMS 5876
<b>ORIFICE SIZE</b>	0.110" (2.8 mm)
<b>FLOW CAPACITY</b>	0.17 Cv
<b>VALVE INTERNAL VOLUME*</b>	0.16 cc
<b>LEAKAGE</b>	1 × 10 <sup>-9</sup> cc/sec helium (inboard)

\* Internal volume in machined passages of the valve body between mounting surface and sealing diaphragm(s).

### Operating Pressures Ratings

	SMALL DIAMETER	MEDIUM DIAMETER	LARGE DIAMETER
<b>VALVE WORKING PRESSURE*</b>	Vacuum (50 torr) to 500 psig	Vacuum (50 torr) to 800 psig	Vacuum (50 torr) to 3600 psig
<b>VALVE PROOF PRESSURE</b>	1000 psig	1600 psig	7200 psig
<b>VALVE BURST PRESSURE</b>	2000 psig	3600 psig	14,400 psig

\* Valves cleaned for oxygen service are limited to 3000 psig (207 bar).

### Operating Temperatures

SEAT MATERIAL	¼-PLUS TURN TEMPERATURE
PCTFE	-40° F to +212° F (-40° C to +100° C)
PEEK™	-40° F to +400° F (-40° C to +204° C)

## Air Actuation Pressure Requirements

psig nominal

PRESSURE	SMALL DIAMETER	MEDIUM DIAMETER	LARGE DIAMETER
Valve Operating Pressure	Vacuum (50 torr) to 500 psig (Inlet)	Vacuum (50 torr) to 800 psig (Inlet)	Vacuum (50 torr) to 3600 psig (Inlet)
Actuation Pressure Normally Closed	40 psig (3 bar) (0–250 psig process pressure)	40 psig (3 bar) (0–250 psig process pressure)	50 psig (0–3600 psig process pressure)
Actuation Pressure Normally Open	40 psig (3 bar) (251–500 psig process pressure)	40 psig (3 bar) (501–800 psig process pressure)	N/A

# DV1 Series

## Dimensions & Materials of Construction

Dimensions are in inches (millimeters) for reference only and are subject to change.

### Normally Open

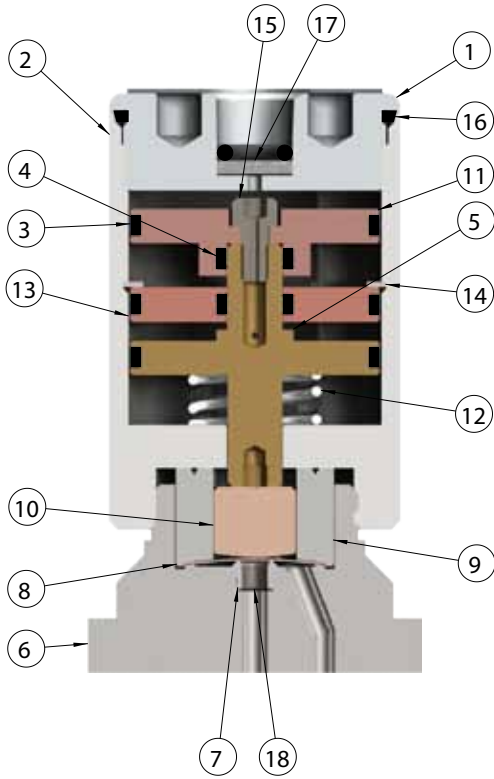

#	PART	MATERIALS
1	Actuator cap	Aluminum, 316L stainless steel, Monel® & Hastelloy® C-276
2	Actuator	Aluminum, 316L stainless steel
3	O-ring	Viton®
4	O-ring	Viton®
5	Piston	Brass
6	Body*	316L stainless steel, Monel® & Hastelloy® C-276
7	Seat*	PCTFE or PEEK®
8	Diaphragm*	Elgiloy® AMS 5876
9	Diaphragm retainer	316 stainless steel
10	Thrust plug	Brass
11	Upper piston	Brass
12	Spring	302 stainless steel
13	Chamber separator	Brass
14	Retaining ring	302 stainless steel
15	Cap screw	Alloy steel
16	O-ring	Viton®
17	Sintered filter	316 stainless steel, 40µ

\* Wetted components

### Normally Closed

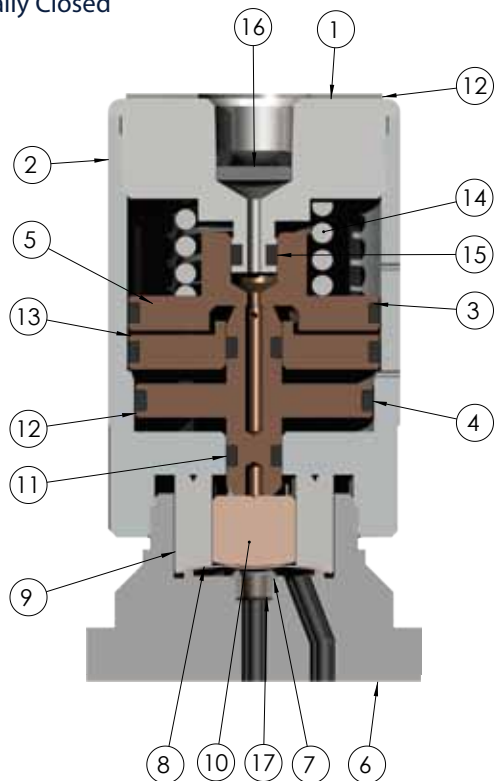

#	PART	MATERIALS
1	Actuator cap	Aluminum, 316L stainless steel, Monel® & Hastelloy® C-276
2	Actuator	Aluminum, 316L stainless steel
3	O-rings	Viton®
4	O-rings	Viton®
5	Upper piston	Brass
6	Body*	316L stainless steel, Monel® & Hastelloy® C-276
7	Seat*	PCTFE (formerly Kel-F®) or PEEK™
8	Diaphragm*	Elgiloy® AMS 5876
9	Diaphragm retainer	316 stainless steel
10	Thrust plug	Brass
11	O-ring	Viton®
12	Lower piston	Brass
13	Chamber separator	Brass
14	Spring	302 stainless steel
15	O-ring	Viton®
16	Sintered filter	316 stainless steel, 40µ

\* Wetted components

# DV1 Series

## Dimensions

### Pneumatic Small Diameter Actuator

END CONNECTION	LENGTH	HEIGHT	ACTUATOR DIAMETER	C/L CENTER LINE
¼" MNPT	2.00" (5.1 cm)	2.75" (7.0 cm)	1.31" (3.3 cm)	0.38" (1.0 cm)
¼" FNPT	2.00" (5.1 cm)	2.75" (7.0 cm)	1.31" (3.3 cm)	0.38" (1.0 cm)
⅜" GYROLOK®	1.71" (4.3 cm)	2.75" (7.0 cm)	1.31" (3.3 cm)	0.38" (1.0 cm)
¼" GYROLOK®	1.87" (4.8 cm)	2.75" (7.0 cm)	1.31" (3.3 cm)	0.38" (1.0 cm)
¼" NPT extended	3.15" (8.0 cm)	2.75" (7.0 cm)	1.31" (3.3 cm)	0.38" (1.0 cm)
6mm GYROLOK®	47.5mm	69.85mm	33.27mm	9.65mm
8mm GYROLOK®	47.5mm	69.85mm	33.27mm	9.65mm

### Pneumatic Medium Diameter Actuator

END CONNECTION	LENGTH	HEIGHT	ACTUATOR DIAMETER	C/L CENTER LINE
¼" MNPT	2.00" (5.1 cm)	2.75" (7.0 cm)	1.56" (4.0 cm)	0.38" (1.0 cm)
¼" FNPT	2.00" (5.1 cm)	2.75" (7.0 cm)	1.56" (4.0 cm)	0.38" (1.0 cm)
⅜" GYROLOK®	1.71" (4.3 cm)	2.75" (7.0 cm)	1.56" (4.0 cm)	0.38" (1.0 cm)
¼" GYROLOK®	1.87" (4.8 cm)	2.75" (7.0 cm)	1.56" (4.0 cm)	0.38" (1.0 cm)
¼" NPT extended	3.15" (8.0 cm)	2.75" (7.0 cm)	1.56" (4.0 cm)	0.38" (1.0 cm)
6mm GYROLOK®	47.5mm	69.85mm	39.62mm	9.65mm
8mm GYROLOK®	47.5mm	69.85mm	39.62mm	9.65mm

### Pneumatic Large Diameter Actuator

END CONNECTION	LENGTH	HEIGHT	ACTUATOR DIAMETER	C/L CENTER LINE
¼" MNPT	2.00" (5.1 cm)	3.25" (8.3 cm)	2.36" (6.0 cm)	0.38" (1.0 cm)
¼" FNPT	2.00" (5.1 cm)	3.25" (8.3 cm)	2.36" (6.0 cm)	0.38" (1.0 cm)
⅜" GYROLOK®	1.71" (4.3 cm)	3.25" (8.3 cm)	2.36" (6.0 cm)	0.38" (1.0 cm)
¼" GYROLOK®	1.87" (4.8 cm)	3.25" (8.3 cm)	2.36" (6.0 cm)	0.38" (1.0 cm)
¼" NPT extended	3.15" (8.0 cm)	3.25" (8.3 cm)	2.36" (6.0 cm)	0.38" (1.0 cm)
6mm GYROLOK®	47.5mm	82.55mm	59.94mm	9.65mm
8mm GYROLOK®	47.5mm	82.55mm	59.94mm	9.65mm

Normally Open

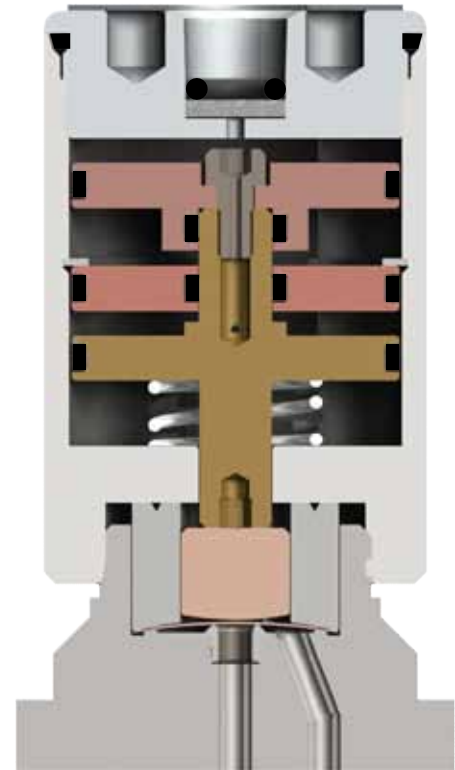

Normally Closed

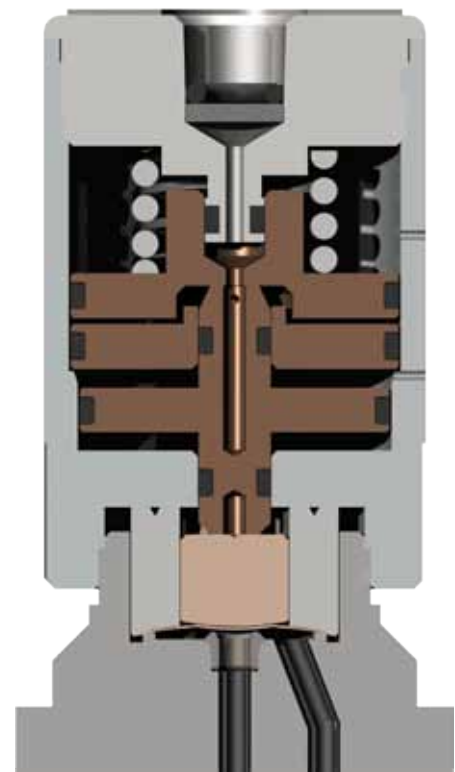

# DV1 Series

## How to Order

Standard items in bold

**DV1 - 1 C 2 5 C F4 F4 H 0 H**

### BODY MATERIAL

- 1 316L stainless steel**
- 4 Monel®**
- 6 Hastelloy® C-276**

### ACTUATION METHOD

- C** Air actuated—normally closed
- M** Manual ¼-plus turn round handle
- O** Air actuated—normally open
- T** Manual ¼-plus turn T-handle

### ACTUATOR SIZE

- X** Manually operated
- 1** Air actuated—small (500 psig max.)
- 2** Air actuated—medium (800 psig max.)
- 3** Air actuated—large (3,600 psig max.)

### ACTUATOR MATERIAL

- X** Manually operated
- 1** 316L stainless steel
- 5** **Aluminum**

### MAXIMUM PROCESS PRESSURE

- A** 250 psig
- B** 500 psig
- C** 800 psig
- D** 3,600 psig (surface mount only)
- E** 2,000 psig

### INLET CONNECTION TYPE\*

- C1** Male **GYROLOK®** ¼"
- G1** **GYROLOK®** ¼"
- G2** **GYROLOK®** ⅜"
- G4** **GYROLOK®** ½"
- T6** **GYROLOK®** 6mm
- T8** **GYROLOK®** 8mm
- F4** **Female NPT ¼"**
- M4** Male NPT ¼"
- B4** Female BSP/ISO 7/1 ¼"
- D4** Male BSP/ISO 7/1 ¼"
- X4** Extended, ¼" male NPT
- SM** Surface mount (ANSI/ISA SP76 compliant)
- V4** ¼" VCR®-compatible swivel female
- R4** ¼" VCR®-compatible fixed male
- W4** ¼" Tube stub
- S4** ¼" Tube socket weld

### OPTION

- 0** None
- 1** Cleaned for oxygen service\*\*
- 4** Panel mount (manual valves only)
- 6** Panel mount & cleaned for oxygen service (manual valves only)\*\*

### SEAT MATERIAL

- H** **PCTFE**
- Q** **PEEK™**

### OUTLET CONNECTION TYPE\*

- C1** Male **GYROLOK®** ¼"
- G1** **GYROLOK®** ¼"
- G2** **GYROLOK®** ⅜"
- G4** **GYROLOK®** ½"
- T6** **GYROLOK®** 6mm
- T8** **GYROLOK®** 8mm
- F4** **Female NPT ¼"**
- M4** Male NPT ¼"
- B4** Female BSP/ISO 7/1 ¼"
- D4** Male BSP/ISO 7/1 ¼"
- X4** Extended, ¼" male NPT
- SM** Surface mount (ANSI/ISA SP76 compliant)
- V4** ¼" VCR®-compatible swivel female
- R4** ¼" VCR®-compatible fixed male
- W4** ¼" Tube stub
- S4** ¼" Tube socket weld

\* Note with the exception of male NPT and female NPT, inlet and outlet connections must be of the same type.

\*\* Valves cleaned for oxygen service are limited to 3000 psig (207 bar). Body will be marked "cleaned for oxygen".

**NOTE:** The choices above represent an abbreviated list of the more commonly ordered options. For a complete listing of all available options, please see the Selection Wizard on the GO website at [www.goreg.com](http://www.goreg.com) or contact the factory.

## For Your Safety

It is solely the responsibility of the system designer and user to select products suitable for their specific application requirements and to ensure proper installation, operation, and maintenance of these products. Material compatibility, product ratings and application details should be considered in the selection. Improper selection or use of products described herein can cause personal injury or property damage.

**GYROLOK®** is a registered trademark of HOKE Incorporated.  
 Viton® is a registered trademark of DuPont Dow Elastomers.  
 Monel® is a registered trademark of Special Metals Corporation.  
 Hastelloy® is a registered trademark of Haynes International, Inc.  
 Elgiloy® is a registered trademark of Elgiloy Specialty Metals.  
 PEEK™ is a trademark of Victrex PLC.

[www.HOKE.com](http://www.HOKE.com)  
[www.dupontelastomers.com](http://www.dupontelastomers.com)  
[www.specialmetals.com](http://www.specialmetals.com)  
[www.haynesintl.com](http://www.haynesintl.com)  
[www.elgiloy.com](http://www.elgiloy.com)  
[www.victrex.com](http://www.victrex.com)





# **CIRCOR**

INSTRUMENTATION TECHNOLOGIES



**CIRCOR Instrumentation Technologies (CIT) is the logical choice for fluid control solutions. We provide the lowest cost of ownership, offering the best in class reliability and availability of our products. We have global coverage, delivering value in the form of local, flexible service to meet our customer's needs. CIT is a product group specializing in instrumentation with orifice sizes typically up to 2".**

**PO Box 4866  
Spartanburg, SC 29305-4866  
Tel +1-864-574-7966  
Fax +1-864-587-5608  
[www.hoke.com](http://www.hoke.com)  
[Sales-hoke@circor.com](mailto:Sales-hoke@circor.com)**

**Our headquarters and ISO 9001:2008 certified  
manufacturing facilities are located at  
405 Centura Court  
Spartanburg, SC, USA, 29303-6603**

**Proudly Distributed By:**

