

MODEL ECO-45

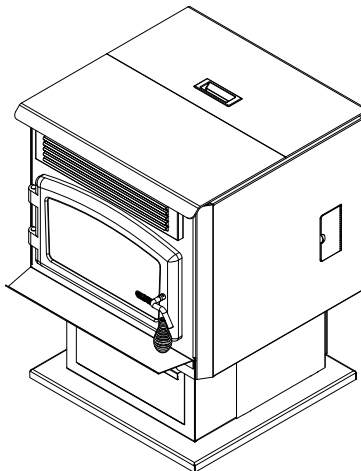

OWNER'S MANUAL

- **Warning:** If your appliance is not properly installed a house fire may result. For your safety, follow the installation directions. Contact local building or fire officials about restrictions and installation inspection requirements in your area.
- **PLEASE** read this entire manual before installation and use of this pellet fuel-burning room heater. Failure to follow these instructions could result in property damage, bodily injury, or even death.
- Save these instructions.
- Some surfaces become hot at higher feeding rates. To prevent potential burns, avoid contact with those areas.
- This heating appliance must serve as a supplementary heat source. An alternative heat source should be available in the home if needed. The manufacturer cannot be responsible for additional heating costs associated with the use of an alternative heat source.
- It is highly recommended that the user buys this product from a retailer who can provide installation and maintenance advice.

PROFESSIONAL INSTALLATION IS HIGHLY RECOMMENDED

**Manufactured by:
Stove Builder International Inc.
Quebec City (Quebec)
CANADA**

Thank you for purchasing the ECO-45 pellet stove. You are now prepared to burn wood in the most efficient, convenient way possible. To achieve the safest, most efficient and most enjoyable performance from your stove, you must do three things: 1) Install it properly; 2) Operate it correctly; and 3) Maintain it regularly. The purpose of this manual is to help you do all three.

PLEASE read this entire manual before installation and use of this palletized wood burning room heater. Failure to follow these instructions could result in property damage, bodily injury or even death.

Keep this manual handy for future reference.

You ECO-45 has been independently tested to ASTM E1509-95 Standard Specification for Room Heaters, Pellet Fuel Burning Type 1, UL 1482-1998 and ULC-S627-00 Standard for Solid Fuel Room Heaters, Oregon Administrative Rules for Mobile Homes (814-23-900 through 814-23-909) and Installation as a Stove Heater.

This pellet stove, when installed, must be electrically grounded in accordance with local codes, or in the absence of local codes, with the *National Electrical Code, ANSI/NFPA 70 and CSA-C22.1*.

This appliance is designed specifically for use only with pelletized wood. It is designed for residential installation according to current national and local building codes as a freestanding room heater. It is also approved as a mobile home heater which is designed for connection to an outside combustion air source.

The stove will not operate using natural draft or without a power source for the blower systems and fuel feed system and must not be burned with any type of coal.

This stove is designed to provide the optimum proportions of fuel and air to the fire in order to burn free of smoke and soot. Any blockage of the air supply to or from the stove will seriously degrade its performance and will be evidenced by a smoking exhaust and a sooting window. For best operation, the ash content of the pellet fuel should be less than 1% and the calorific value approximately 8,200 BTU/LB. Avoid high ash content fuels because this will rapidly fill up the burn pot and eventually cut off the combustion air supply.

Commercial and industrial installations of the ECO-45 should not be used since operational control is often not well managed in these settings.

REGISTER YOUR WARRANTY ONLINE

To receive full warranty coverage, you will need to show evidence of the date you purchased your stove. Keep your sales invoice. We also recommend that you register your warranty online at

www.drolet.ca

Registering your warranty online will help us track rapidly the information we need on your stove.



- Do not operate your stove if you smell smoke coming from it. Turn it off, monitor it, and call your dealer.



- Never use gasoline, gasoline-type lantern fuel, kerosene, charcoal lighter fluid, or similar liquids to start or "freshen up" a fire in this stove. Keep all such liquids well away from the stove while in use.



- Never block free airflow through the open vents of the stove.



- Never try to repair or replace any part of the stove unless instructions are given in this manual. All other work should be done by a trained technician.



- The stove will not operate during a power outage. If an outage does occur, check the stove for smoke spillage and open a window if any smoke spills into the room.



- Disconnect the power cord before performing any maintenance or repairs on the stove.
NOTE: Turning the stove "off" does not disconnect all power from the stove.



- Do not unplug the stove if you suspect a malfunction. Turn the stove off, periodically inspect it, and call your dealer.



- Keep foreign objects out of the hopper.



- Do not throw this manual away. This manual has important operating and maintenance instructions that you will need at a later time. Always follow the instructions in this manual.



- Do not place clothing or other flammable items on or near the stove.



- The viewing door must be closed and latched during operation.



- Do not operate the stove if the flame becomes dark and sooty or if the burn pot overfills with pellets. Turn the stove off, periodically inspect it, and call your dealer.



- Do not touch the hot surfaces of the heater. Educate all children of the danger of a high temperature stove. Young children should be supervised when they are in the same room as the stove.



- If the stove is installed in a room without air conditioning, or in an area where direct sunlight can shine on the unit, it is possible this can cause the temperature of the stove to rise to operational levels; one of the sensors could then make the stove start on its own. It is recommended that the stove be unplugged when not in use for extended amounts of time (i.e. during the summer months).



- Contact your local building officials to obtain a permit and information on any installation restrictions or inspection requirements in your area. Notify your insurance company of this stove as well.



- The exhaust system **must** be completely airtight and properly installed. The pellet vent joints must be sealed with RTV 500°F. (260°C.) silicone sealant, and with UL-181-AP foil tape.



- This unit must be properly installed to prevent the possibility of a house fire. The instructions must be strictly adhered to. Do not use makeshift methods or compromise in the installation.



- Your stove requires periodic maintenance and cleaning. Failure to maintain your stove may lead to smoke spillage in your home.



- Allow the stove to cool before carrying out any maintenance or cleaning. Ashes must be disposed in a metal container with a tight lid and placed on a non combustible surface well away from the home structure.



- This stove is designed and approved for pelletized wood fuel only. Any other type of fuel burned in this heater will void the warranty and safety listing.



- This stove must be connected to a standard 120 V., 60 Hz grounded electrical outlet. Do not use an adapter plug or sever the grounding plug. Do not route the electrical cord underneath, in front of, or over the stove.



- When installed in a mobile home, the stove must be bolted to the floor, have outside air, and **NOT BE INSTALLED IN A BEDROOM** (Per H.U.D. requirements). Check with local building officials.



- The exhaust system should be checked, at a minimum, at least twice a year for any build up of soot or creosote.



- **Stove Builder International Inc. grants no warranty, implied or stated, for the installation or maintenance of your stove, and assumes no responsibility of any consequential damage(s).**

| | | |
|--|-------|----|
| INTRODUCTION | ----- | 2 |
| SAFETY PRECAUTIONS | ----- | 3 |
| SPECIFICATIONS | ----- | 5 |
| INSTALLATION | ----- | 5 |
| Preparation | ----- | 5 |
| Clearances | ----- | 5 |
| Combustion Air Supply | ----- | 6 |
| When Outside Air Is Not Used | ----- | 6 |
| Venting | ----- | 6 |
| Freestanding Installations | ----- | 7 |
| Log set installation | ----- | 10 |
| OPERATION | ----- | 11 |
| Proper Fuel | ----- | 11 |
| Pre-Start-Up Check | ----- | 11 |
| Building a Fire | ----- | 11 |
| Lighting procedure | ----- | 11 |
| Unit Controls | ----- | 11 |
| Opening Door | ----- | 12 |
| Convection blower | ----- | 12 |
| If Stove Runs Out Of Pellets | ----- | 13 |
| Damper Control | ----- | 13 |
| Refueling | ----- | 13 |
| Shutdown Procedure | ----- | 13 |
| Safety Features | ----- | 13 |
| Optional Thermostat | ----- | 14 |
| Thermostat Installation | ----- | 14 |
| (Please Read This) Operating Safety Precautions | ----- | 15 |
| MAINTENANCE | ----- | 16 |
| Ash Removal | ----- | 16 |
| Ash Disposal | ----- | 16 |
| Vacuum Use | ----- | 17 |
| Cleaning | ----- | 17 |
| Blowers | ----- | 17 |
| Chimney Cleaning | ----- | 18 |
| Recommended Maintenance Schedule | ----- | 18 |
| Removal & Replacement of Broken Door Glass | ----- | 18 |
| TROUBLE SHOOTING GUIDE | ----- | 19 |
| ELECTRICAL DIAGRAM | ----- | 25 |
| REPLACEMENT PARTS LIST | ----- | 26 |
| HORIZONTAL/VERTICAL VENT CHART | ----- | 27 |
| WARRANTY | ----- | 28 |

ECO-45 FREESTANDING PELLETS STOVE

Width: 27"

Height: 30 1/2"

Depth: 24 5/8"

Weight: 230 lbs.

Flue size: 3" or 4"

Hopper Capacity: Up to 60 lbs.

(This can vary widely depending on pellet size, length, and diameter)

EPA status: exempt

Burn rate: 1.3 lbs to 5.5 lbs per hour

BTU range: 8,200 to 45,000

Electrical consumption: 3.5 Amps lighting cycle

2.5 Amps. continuous duty

Control board fuses: Main: 7.5A-250V fastblow

Igniter: 5A-250V fastblow

Electrical requirement: 120VAC 15A

Approved installations: mobile home, conventional

PREPARATION

Factory packaging must be removed, and some minor assembly work is required prior to installation:

- The black knob must be attached to heat exchanger rod;
- The black coil handle must be attached to the handle rod.

CLEARANCES

The ECO-45 has been tested and listed for installation in residential, mobile home.(refer figure 1 & 2)

FLOOR PROTECTION: minimum 6" in the front and 6" on each side. The stove must be placed on a continuous (grouted joints) noncombustible material such as ceramic tile, cement board, brick, 3/8" millboard or equivalent, or other approved or listed material suited for floor protection. NOTE: ceramic tile, or any tile, requires a continuous sheet beneath to prevent the possibility of embers falling through to the combustible floor if cracks or separation should occur in the finished surface, this would include floor protection for Built-in raised hearths. Check local codes for approved alternatives.

Clearances are measured from the sides, back and face (door opening) or stove body (refer to fig. 3).

DO NOT USE MAKESHIFT MATERIALS OR COMPROMISES IN THE INSTALLATION OF THIS UNIT.

INSTALL VENT WITH CLEARANCES SPECIFIED BY THE VENT MANUFACTURER.

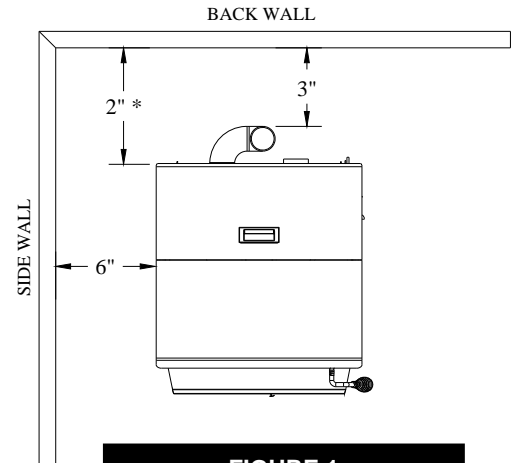

**FIGURE 1
Back wall installation**

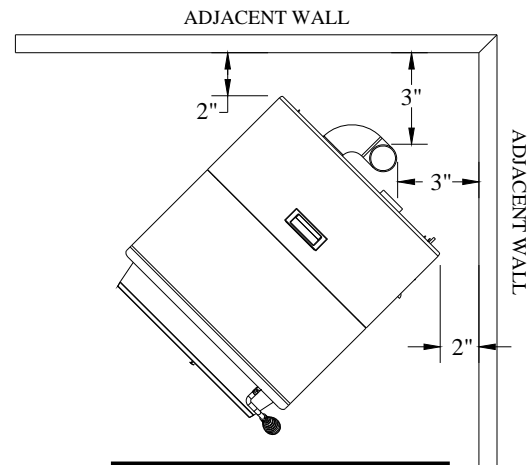

**FIGURE 2
Corner installation**

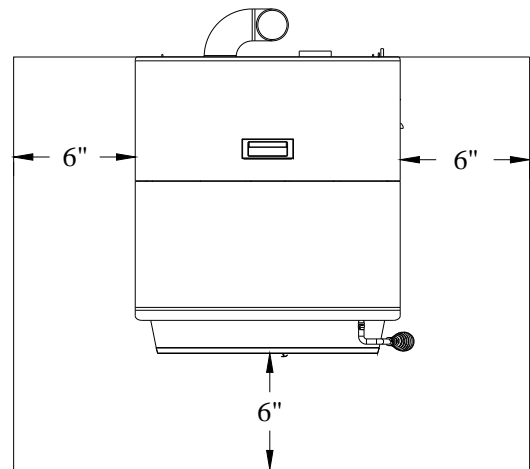

**FIGURE 3
Floor protection**

COMBUSTION AIR SUPPLY

For a mobile home installation the stove must be connected to an outside source of combustion air. A 3" inside diameter metallic pipe, either flexible or rigid, may be attached to the inlet at the stove's rear (refer to figures 4, 5 & 6). A rodent guard (minimum ¼" wire mesh) must be used at the terminus (refer to figure 5). All connections must be secured and airtight by either using the appropriately sized hose clamp and/or UL-181-AP foil tape.

For mobile home installations only: No combustion air supply may exceed 10 feet.

Sources of Outside Combustion Air

- A hole in floor near stove rear terminating only in a ventilated crawl space.
- A hole in the wall behind the stove.

WHEN OUTSIDE AIR IS NOT USED

If outside air is not used, it is important that combustion air be easily available to the air inlet. A closeable outside air register can be used in tightly insulated homes.

VENTING

The ECO-45 is certified for use with a vent certified to UL-103 or ULC S629M and a chimney type vent certified to UL-641 or ULC-S-609-M89 and ULC/ORD C441-M90, with 3" or 4" inner diameter. In Canada, we recommend that you use a listed pellet vent that meets the ULC S-609-M89 and ULC/ORD C441-M90 Standards. For the United States, we recommend that you use a listed pellet vent that meets the UL-641, 7th edition Standard. This unit can be vented in an existing chimney with the addition of a liner if the chimney is more than 4" in diameter. Class "A" chimney is not required. Refer to the instructions provided by the vent or chimney manufacturer, especially when passing through a wall, ceiling, or roof.

Your venting system should have at least one foot of vertical rise for each foot of horizontal run. The total vertical rise should never be less than 3 feet (see Appendix A).

This is a pressurized exhaust system. All vent connector joints must be sealed with 500°F (260°C) RTV silicone sealant to ensure consistent performance and avoid smoke spillage. All horizontal connector joints must be sealed with UL-181-AP foil tape. We recommend that all vertical vent connector joints be secured with a minimum of 3 screws.

DO NOT CONNECT THIS UNIT TO A CHIMNEY FLUE SERVING ANOTHER APPLIANCE.

DO NOT INSTALL A FLUE DAMPER IN THE EXHAUST VENTING SYSTEM OF THIS UNIT.

INSTALL VENT AT CLEARANCES SPECIFIED BY THE VENT MANUFACTURER.

WARNING: DO NOT INSTALL IN SLEEPING ROOM

CAUTION: THE STRUCTURAL INTEGRITY OF THE MANUFACTURED HOME FLOOR, WALL, AND CEILING/ROOF MUST BE MAINTAINED

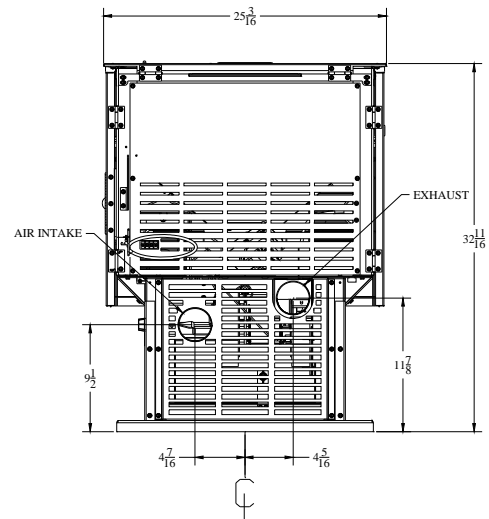

FIGURE 4
Rear view

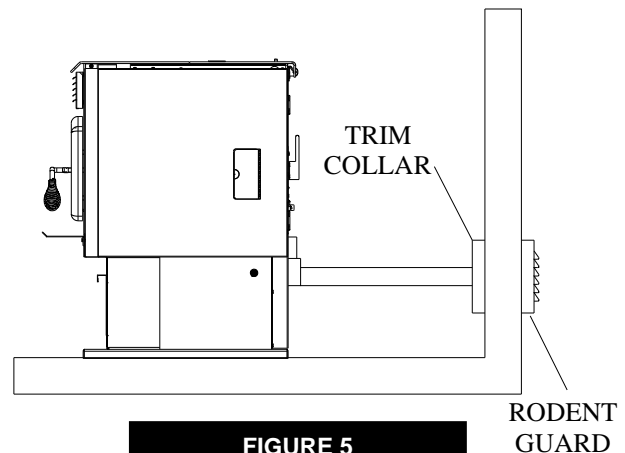

FIGURE 5
Fresh air supply

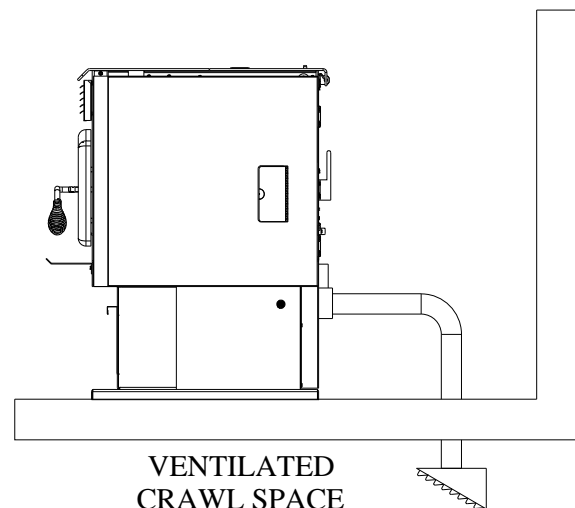

FIGURE 6
Fresh air supply

Equivalent Vent Length (EVL)

The longer the run of pipe in your installation, the more restriction there is in the system. Therefore, larger diameter pipe should be used.

- Use 4" pipe if you have more than **15 feet** of Equivalent Vent Length (EVL).
- Horizontal runs shall not exceed 10 feet of EVL.
- To calculate EVL, use the following conversions table:

| Qty | Type of pipe | EVL equivalent(ft) |
|------|---------------------|--------------------|
| 1 | 90° elbow or "T" | 5 |
| 1 | 45° elbow | 3 |
| 1 ft | Horizontal pipe run | 1 |
| 1 ft | Vertical pipe run | 0.5 |

NOTE: At altitudes above 3,000 feet, we suggest the use of 4" diameter vent at an EVL of 7 feet or more.

Here is an example on how to calculate the EVL of your installation. (See Figure 8)

$(3 \times 4'$ of vertical length = $12' \times 0.5 = 6$ EVL) + $(1 \times$ elbow or "T" = 5 EVL) + $(2 \times 1'$ of horizontal length = 2 EVL)

Total EVL = $(6 + 5 + 2) = 13$. So 3" diameter vent is allowed

INSTALLATION CONFIGURATIONS

A. HORIZONTALLY THROUGH WALL (refer to Figure 7 & 8)

NOTE: Follow the vent manufacturer's instructions.

1. Position stove, adhering to clearances shown in Figures 1 & 2.
2. Locate position of hole in wall; directly behind stove exhaust vent (refer to figure 4).
3. Always maintain 3" clearance from combustible materials.
4. Install a wall thimble as per the vent manufacturer's instructions.
5. Attach enough piping to penetrate and extend at least 6" beyond exterior walls. An 8-foot vertical pipe run is suggested where possible to reduce the possibility of smoke spillage in the event of a loss of negative pressure.
6. Attach cap and seal outside wall thimbles with non-hardening waterproof mastic.

Termination should not be located so that hot exhaust gases can ignite trees, shrubs, or grasses or be a hazard to children. Exhaust gases can reach temperatures of 500°F and cause serious burns if touched.

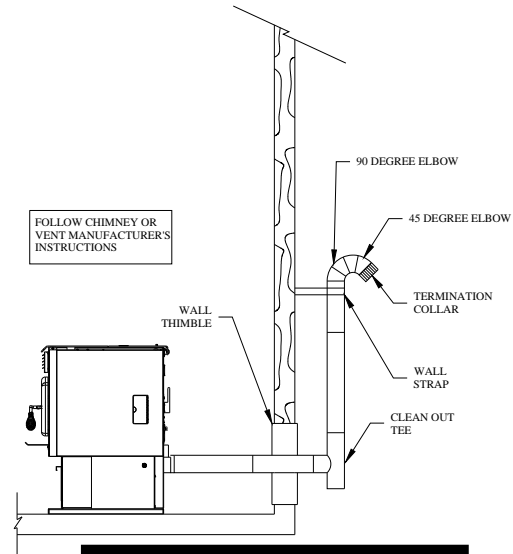

FIGURE 7
Venting through wall

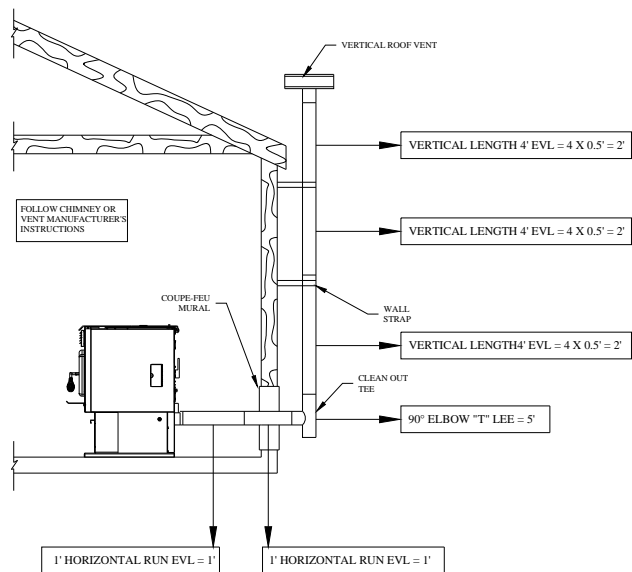

FIGURE 8
Venting through wall

Locate terminations: a) not less than 3 feet above any forced air inlet located within 10 feet; b) not less than 4 feet below or horizontally from, or one foot above, any door, window or gravity air inlet into any building; c) not less than two feet from an adjacent building and not less than 7 feet above grade when located adjacent to a public walkway. Mobile home installations must use a spark arrester. Other restrictions may apply, such as the need to maintain a minimum distance to a gas meter. US and Canadian Standards may vary. **Consult the vent manufacturer's instructions.**

A. VERTICALLY WITH NEW CHIMNEY SYSTEM (Refer to Figure 9 & 10 for basement installation)

NOTE: Follow the vent manufacturer's instructions.

OPTION: To achieve a center vertical installation, a 45° elbow and a clean-out tee can be used to offset the pipe from the exhaust outlet to the rear center of the stove.

OPTION: Install an elbow in place of clean-out tee. Locate stove. Drop plumb bob to center of tee outlet, mark point on ceiling. Install ceiling support and vent as per vent manufacturer's instructions.

1. Always maintain 3" clearance from combustible materials. When passing through additional floors or ceilings, always install firestop spacer.
2. After lining up for hole in roof, cut either around or square hole in roof, always 3" larger all the way around pipe. Install upper edge and sides of flashing under roofing materials, nail to the roof along upper edge. Do not nail lower edge. Seal nail heads with non-hardening waterproof mastic.
3. Apply non-hardening, waterproof mastic where the storm collar will meet the vent. Slide storm collar down until it sits on the flashing. Seal and install cap. Mobile home installations must use a spark arrester.

B. VERTICALLY INTO EXISTING CHIMNEY SYSTEM

As an alternative, 3" or 4" vent can be run inside existing chimney to termination (Figure 11). This is the preferred method.

Follow guidelines for equivalent vent length.

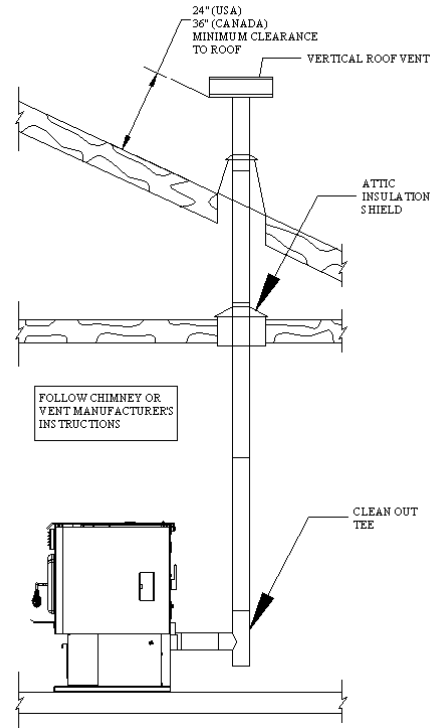

FIGURE 9
Venting through roof

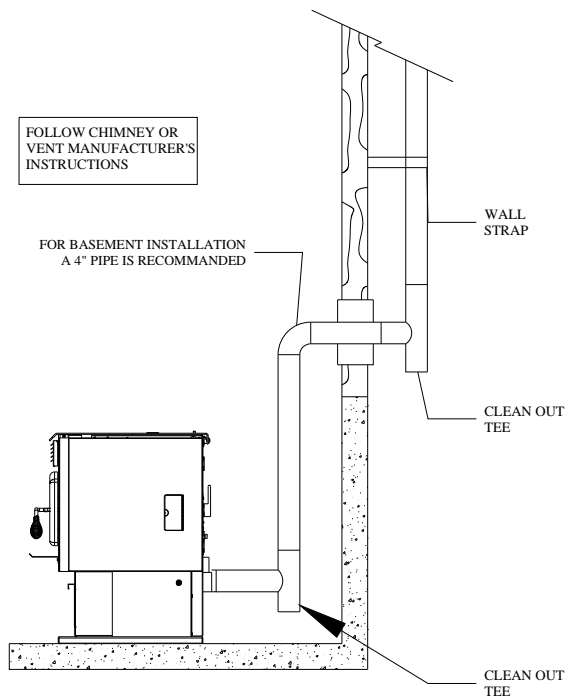

FIGURE 10
Basement installation

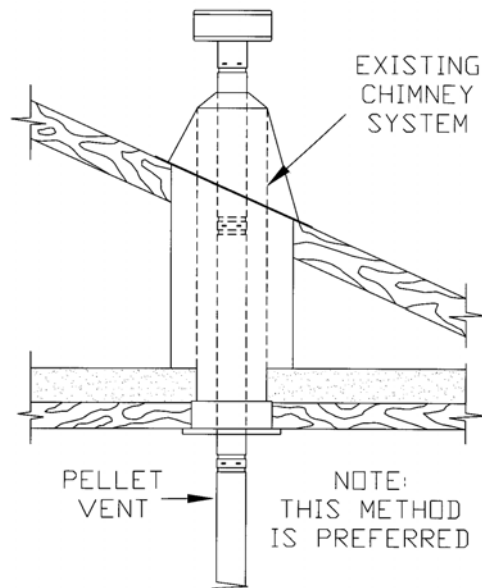

FIGURE 11
Venting through existing chimney

C. VERTICALLY INTO EXISTING MASONRY FIREPLACE

NOTE: Follow the vent manufacturer's instructions.

1. Have the masonry chimney inspected by a qualified chimney sweep or installer to determine its structural condition.
2. You will need a pipe length equal to the chimney height from the hearth. If outside combustion air is to be used, you will need a pipe length equal to the chimney height plus 18 inches.
3. Install a blanking plate and the chimney pipe, and if used the outside air pipe, as shown in Figure 12.
4. Attach the DuraVent adapter, a section of pipe and clean out tee, making sure the clean out tee is centered in the chimney flue area. Use RTV, metallic tape, and a minimum of three self-taping screws at all joint connections to ensure a tight seal.
5. Position the stove, adhering to the clearances in Figures 1 & 2.
6. Measure and build chimney top plate. Cut out holes for chimney pipe, and if used the outside air pipe. Install and seal with non-hardening mastic to prevent water leakage. Install vent cap.

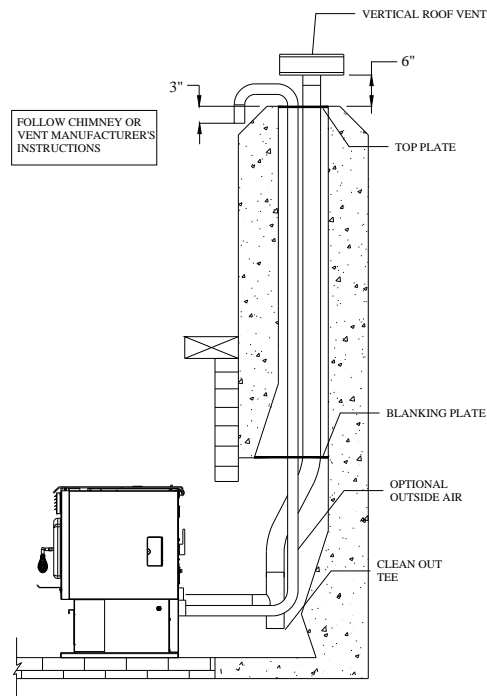

Figure 12
Venting through masonry chimney

D. INSTALLATION THROUGH SIDE OF MASONRY CHIMNEY

NOTE: Follow vent manufacturer's instructions.

1. Position the stove, adhering to the clearances in Figures 1 & 2. Mark the center of the hole where the pipe is to pierce the masonry chimney.
2. It will be necessary to break out the masonry around the location of the pipe center mark. Use a 4-inch diameter hole for 3-inch pipe and 5-inch diameter hole for 4-inch pipe.
3. Measure and build chimney top plate. Cut out holes for chimney pipe, and if used the outside air pipe.
4. Install the tee on the bottom of the vertical pipe system and lower it down the chimney until the center branch of the tee is level with the center of the hole in the masonry, as shown in Figure 13.
5. Install and seal the top plate from step 3 with non-hardening mastic. Slip the storm collar over the pipe, and while holding the pipe at the proper elevation, affix the collar with a minimum of three ¼" stainless steel sheet metal screws. Seal all joints and seams around the collar.
6. Connect the horizontal pipe by pushing it through the hole in the masonry and lining it up with the branch in the tee. Push the pipe into the tee while twisting it to lock it into the tee.
7. If desired, once the horizontal pipe is in place, the space between the pipe and masonry may be filled with high-temperature grout.

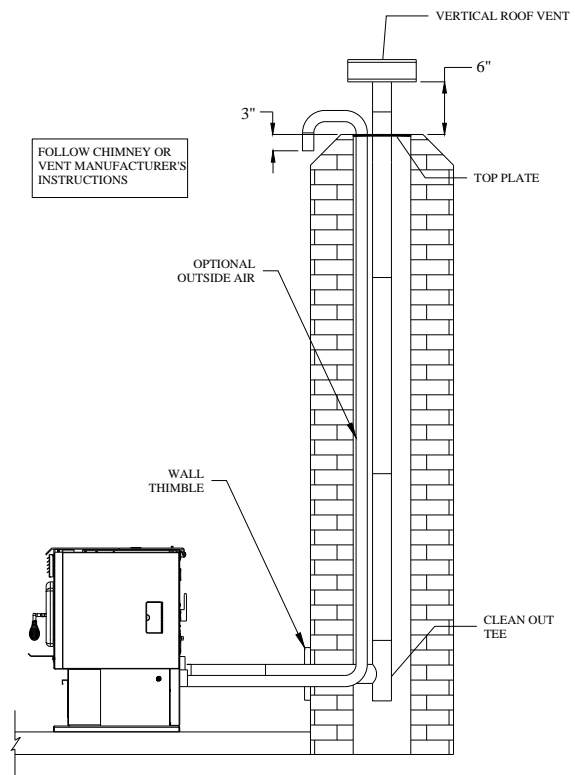

Figure 13
Venting through side of masonry chimney

Install the trim collar. An adjustable pipe length and adapter may be needed to finish the connection to the stove.

OPTIONAL LOG SET INSTALLATION

To install the optional log set, you first need to remove the four screws indicated on figure 14a. Keep the screws. Locate the two fixation brackets figure 14b that came with your owner's manual. Fix the two brackets using the same screws you have removed. Lay the log set inside the firebox as shown on figure 14d & 14e

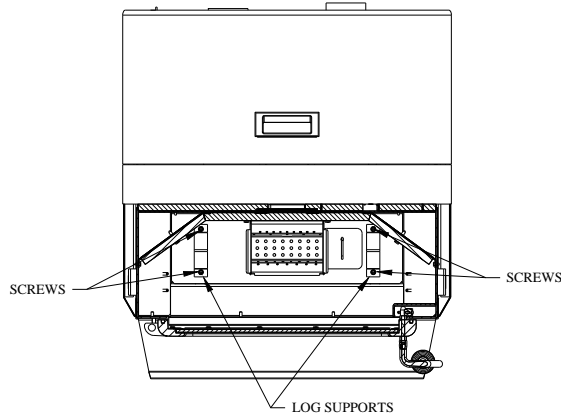

Figure 14a
Fixation of supports

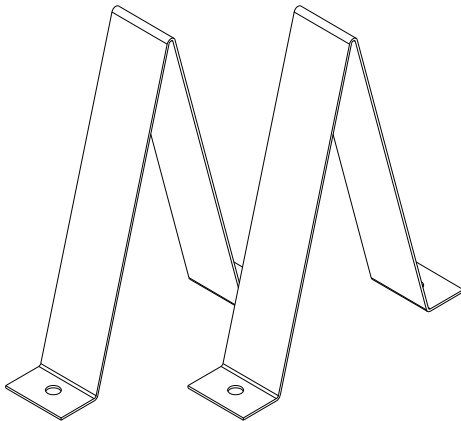

Figure 14b
Log set supports

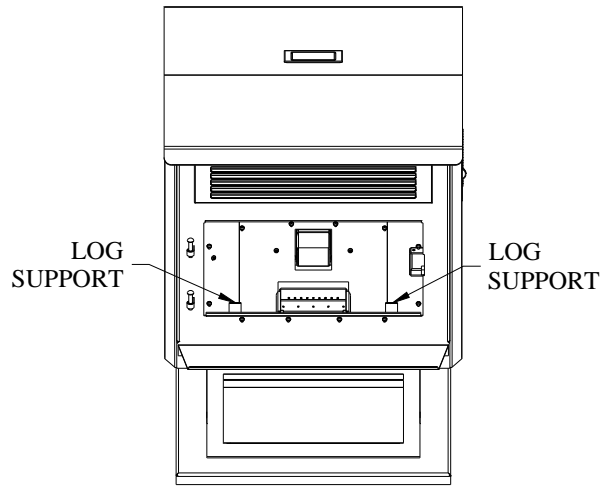

Figure 14c
Location of supports

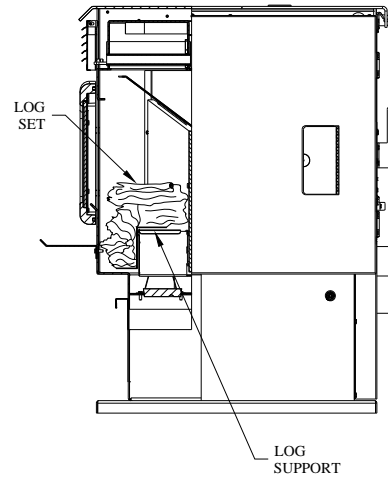

Figure 14d
Log set positioning

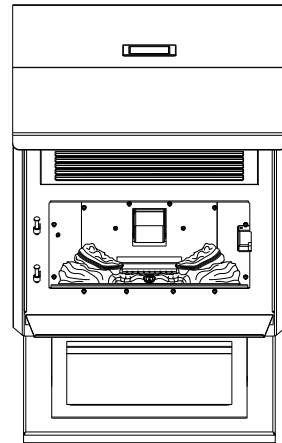

Figure 14e
Log set positioning

PROPER FUEL

THIS STOVE IS APPROVED FOR BURNING PELLETIZED WOOD FUEL ONLY! Factory-approved pellets are those ¼" or 5/16" in diameter and not over 1" long. Longer or thicker pellets sometimes bridge the auger flights, which prevents proper pellet feed. **Burning wood in forms other than pellets is not permitted. It will violate the building codes for which the stove has been approved and will void all warranties.** The design incorporates automatic feed of the pellet fuel into the fire at a carefully prescribed rate. Any additional fuel introduced by hand will not increase heat output but may seriously impair the stoves performance by generating considerable smoke. Do not burn wet pellets. The stove's performance depends heavily on the quality of your pellet fuel. Avoid pellet brands that display these characteristics:

- a. **Excess Fines** – "Fines" is a term describing crushed pellets or loose material that looks like sawdust or sand. Pellets can be screened before being placed in hopper to remove most fines.
- b. **Binders** – Some pellets are produced with materials to hold them together, or "bind" them.
- c. **High ash content** – Poor quality pellets will often create smoke and dirty glass. They will create a need for more frequent maintenance. You will have to empty the burn pot plus vacuum the entire system more often. Poor quality pellets could damage the auger. Drolet cannot accept responsibility for damage due to poor quality pellets. The pellet ash content should be less than 1%. The pellet grade and ash content should be indicated on the bag by the pellet manufacturer.

PRE-START-UP CHECK

Remove burn pot, making sure it is clean and none of the air holes are plugged. Clean the firebox, and then reinstall burn pot. Clean door glass if necessary (a dry cloth or paper towel is usually sufficient). Never use abrasive cleaners on the glass or door. Check fuel in the hopper, and refill if necessary.

BUILDING A FIRE

Never use a grate or other means of supporting the fuel. Use only the Drolet approved burn pot.

NOTE: During the first few fires, your stove will emit an odor and a small amount of fumes as the high temperature paint cures or becomes seasoned to the metal. Maintaining smaller fires will minimize this. Avoid placing items on stovetop during this period because paint could be affected. Make sure the room is well-ventilated. Open windows. **Odors and fumes released during this process are unpleasant but they are not toxic.**

LIGHTING PROCEDURE

- a. Fill hopper and clean burn pot.
- b. Press "MODE" button to select the desired setting "MANUAL" or "THERMOSTAT"
- c. If the flame is too low in burn pot or the unit has difficulty to light, reduce the air supply by turning the air supply control knob toward the minimum setting. The knob is located on the side of the unit. Once the fire is established, adjust the air supply knob to the desired flame height.
- d. Adjust feed rate to desired setting by pressing "-" or "+" button.

If fire doesn't start in 30 minutes, refer to troubleshooting section.

UNIT CONTROLS (See Figure 15)

The blowers and automatic fuel supply are controlled from a panel on the right-hand side of the ECO-45. The control panel functions are as follows.

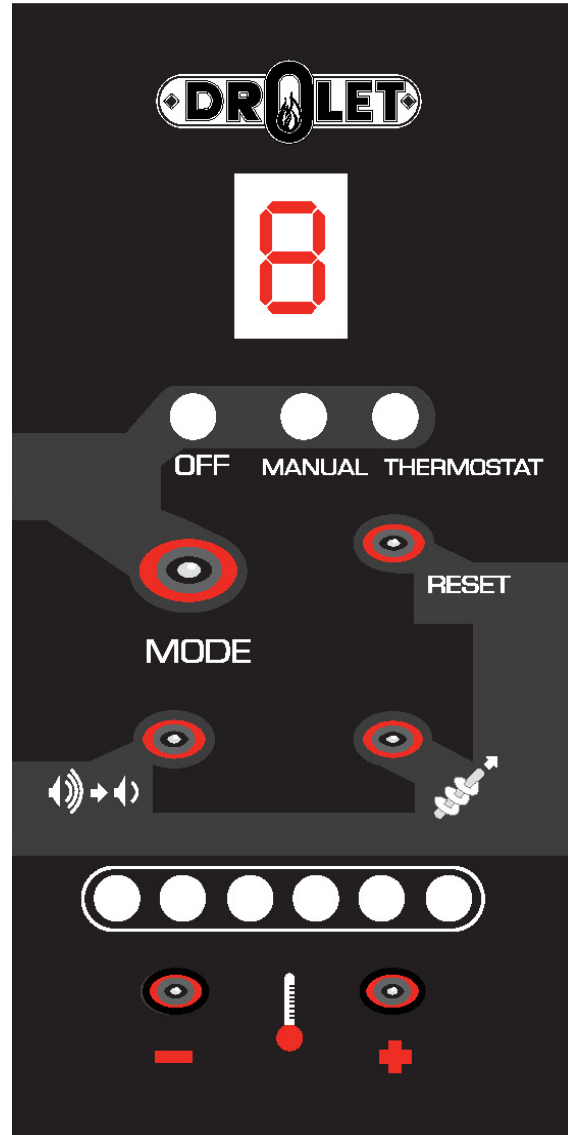

FIGURE 15
PC board



a. **MODE SWITCH**

- When the mode switch is pressed, the stove will automatically ignite. If the manual mode is selected, the heat level must be selected manually to adjust the stove's heat output to the desired level. If the thermostat mode is selected, the stove will automatically modulate between the lowest heat level and the heat level selected to keep the room temperature at the thermostat's setting. If the set room temperature is achieved while the stove has been running at the lowest heat level for more than 45 minutes, the unit will automatically shut off and will start another ignition cycle only when the thermostat calls for heat again. No fire starter is necessary to ignite the unit. The auger will feed fuel for 4 minutes and the electronic igniter will stay on for 10 minutes. If the unit doesn't ignite within 15 minutes, the stove will wait for 5 minutes and will start a second ignition cycle. If ignition fails a second time, a warning message will appear on control panel.
- The Heat Level may be selected during the ignition cycle. However, the unit will only feed fuel at the desired heat level setting when the heat sensor located into the stove will receive a signal indicating that the unit has been fully ignited. This may take anywhere between 10 and 15 minutes.



b. **FUEL FEED SWITCH**

- When the "Fuel Feed" button is pushed and held down the stove will feed pellets continuously into the burn pot.

CAUTION: THIS FUNCTION CAN ONLY BE OPERATED WHEN THE STOVE IS IN "OFF" POSITION. THE FUEL FEED SWITCH IS USED TO PRIME THE AUGER WHEN AUGER IS EMPTY.



c. **NOISE REDUCER**

- The convection blower speed varies directly with the fuel feed rate.
- When the "NOISE REDUCER" button is pushed, the convection blower will switch to its lowest speed. The convection blower will remain at its lowest speed unless the stove reaches a certain temperature. If this occurs, the convection blower will go back to its highest setting to cool down the stove. The low noise button will have to be pressed again for the convection blower to go back to its lowest speed. Please note that the difference in noise level may not be noticeable on units manufactured after October 2007, (with serial #1677 or above). Those units already use two ultra-quiet tubeaxial convection blowers that produce a very low noise even at full speed.

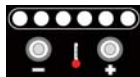

d. **HEAT LEVEL**

- By pressing "+" or "-", you can set the pellet feed rate and hence the heat output of your stove. The levels of heat output will incrementally change and each LED indicate the level from 1 to 6.



e. **RESET**

Reset button has to be used to clear any warning on the control and restart your stove.

OPENING DOOR

The door should be open only for maintenance purposes.

CONVECTION BLOWER (ROOM AIR FAN)

Upon starting your stove, the convection blower will not come on until the stove's heat exchanger warms up. This usually takes about 10 to 15 minutes from start-up. Speed will vary with the selected feed rate, except if the noise reducer mode has been activated.

COMBEXtm

Your stove uses a unique patented technology called COMBEX. As opposed to most other pellet stoves, which use only an exhaust blower, your ECO-45 uses a motor on which are mounted two housings with impeller blades. One housing serves for combustion, and the other for exhaust. This is why we refer to the combustion/exhaust blower throughout this manual. The COMBEX system balances combustion air and uptake to provide clean, worry-free combustion which is less dependent on the leak-tightness of the device and the quality of the combustible.

IF THE STOVE RUNS OUT OF PELLETS

The fire goes out and the auger motor and blowers will run until the stove cools down. This will take a few minutes.

After the stove's components stop running, a warning message will appear .

To restart, press the "RESET" button, refill the hopper, and press the "FUEL FEED" button  until pellets begin to fall into the burn pot. Press the "MODE" button to start the unit on Manual or Thermostatic mode.

DAMPER CONTROL

The damper control rod on the stove's lower right side adjusts the combustion air. This control is necessary due to the varied burn characteristics of individual installations and different pellet brands. It allows you to improve the efficiency of your stove. Providing correct combustion air will reduce the frequency of cleaning your glass door and prevent the rapid buildup of creosote inside your stove and chimney.

You should adjust the damper based on the fire's appearance. A low, reddish, dirty fire can be improved by increasing the air supply using the control knob located on the side of the unit. A "blow torch" fire can be improved by reducing the air supply.

Through trial and error, you will find the best setting. Consult your dealer if you need help.

REFUELING

We recommend that you not let the hopper drop below ¼ full. If the reload lid stays for open more than 3 minutes, a warning  will appear. To restart, press the "RESET" button, and then press the "MODE" button to start the unit on Manual or Thermostatic mode.

KEEP HOPPER LID CLOSED AT ALL TIMES EXCEPT WHEN REFILLING. THE HOPPER MAY BE FILLED WHILE THE STOVE IS OPERATING. DO NOT OVERFILL HOPPER.

SHUTDOWN PROCEDURE

Turning your Drolet stove off is a matter of pressing the "MODE" control panel switch, until the "OFF" led goes on. The blowers will continue to operate until internal firebox temperatures have fallen to a preset level.



SAFETY FEATURES

- Your stove is equipped with a re-settable high temperature switch (also called heat sensor or heat switch). The switch has a reset button on its backside. Like a circuit breaker, once tripped, the reset button will have to be pushed before you can restart the stove. The high temperature switch is there to protect the stove from overheating in case of an evacuation problem, a control board problem, a blower problem, or any other problem causing the unit to overheat. The manufacturer recommends that you call your dealer if this occurs as it may indicate a more serious problem. A service call may be required.

NOTE: If an overheating situation occurs, the high temperature switch (called the L-250 manual reset) will automatically shut down the auger (fuel feed system) and a warning code  will appear.

- If the combustion blower fails, an air pressure switch will automatically shut down the auger and a warning message  will appear. This safety feature is to prevent the unit from burning fuel when the combustion/exhaust blower has failed, therefore preventing combustion fumes from spilling into the room.

- If the temperature in the auger rises beyond a certain acceptable level, a second high temperature switch located on the auger housing will stop the fuel feed system and an warning  will appear.

| CODE | BEFORE RESETTING | TO RESET |
|--|--|--|
| H1, H2, H3 OR H4 | Heat exchanger and/or exhaust system is/are clogged. Refer to the owner's manual for maintenance procedures. | Press simultaneously for 2 seconds  and  . |
| *** After 3 attempts, reset is no longer possible, call SBI technical support. | | |

OPERATING THE STOVE USING A THERMOSTAT

A thermostat may help you maintain a constant house temperature automatically. A millivolt thermostat or 24 Volt thermostat is required. A fixed wall mount or hand held model can be used. The control panel can be set up two ways to operate your stove in thermostatic mode.

THERMOSTAT INSTALLATION

- Unplug the stove from the power outlet.
- Connect two thermostat wires to the terminal block located on the lower right side of the back of the stove. To do so, loosen the two screws and insert the wires in the terminals. Tighten the two screws. (See figure 16)
- If you are using a wireless wall thermostat or a hand held thermostatic remote control, you can locate the receiver behind the stove's back panel, on the right end side, just below the terminal block. Most receivers are already equipped with quick-connect terminals. Simply unplug the PC board wires connected to the back of the terminal block and connect them directly with the receiver's terminals. Location of the thermostat is very important to obtain the best comfort and efficiency from you ECO-45. The thermostat should be mounted 50 inch from the floor on a wall located 15 to 20 feet from the stove. You should avoid an installation directly in front of the stove to avoid cycling. (See figure 17)

MODES

THERMOSTATIC MODE

- To use this mode, the "MODE" button must be pushed to "Thermostat" upon starting the stove. The heat setting is then selected using the "Heat Level" selector "+ or -". When set in thermostatic mode, the stove will automatically run at the heat level selected until the set room temperature is reached. When that occurs, the stove will switch to heat setting #1 (lowest) until the thermostat calls for heat again. The convection blower will also slow to its lowest speed. When the thermostat calls for heat again, the stove will increase its feed rate to match the heat setting selected.
- **N.B.:** If the room temperature remains stable and the thermostat does not call for heat during at least 45 minutes, the stove will shut down. When the thermostat calls for heat again, the stove will start an ignition cycle. Once the ignition cycle is completed, the stove will increase its feed rate to match the heat setting selected.

NOTE: When in thermostatic mode:

- You should not operate the manual control or play with the temperature setting.
- YOUR THERMOSTAT SHOULD BE INSTALLED BY AN AUTHORIZED DEALER OR SERVICE PERSON.

THERMOSTAT
TERMINAL

FIGURE 16
Rear view



D = MINIMUM DISTANCE 15 FEET

FIGURE 17
Thermostat location

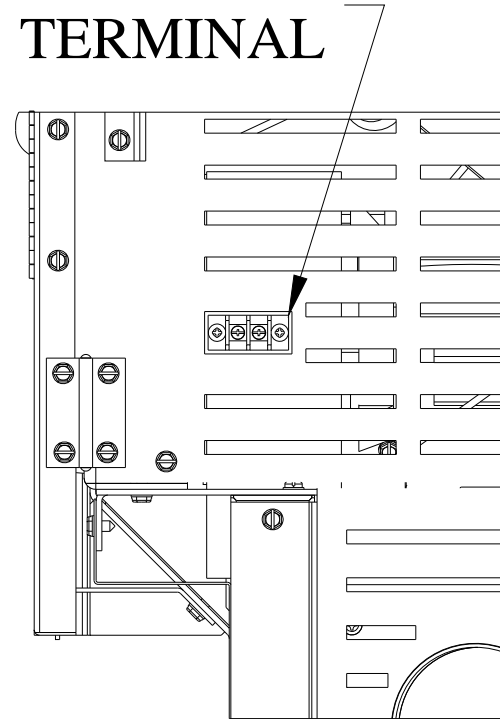
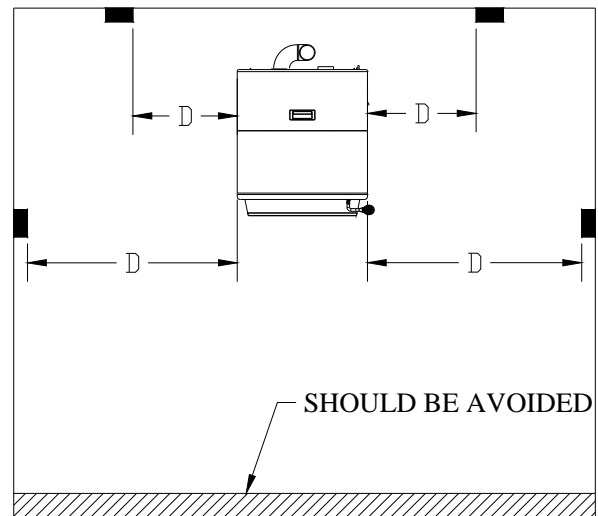
OPERATING SAFETY PRECAUTIONS

PLEASE READ THIS!

- a. **If you notice a smoldering fire** (burnpot full but no visible flame) **AND a heavy smoke buildup in firebox, immediately TURN OFF the stove, but DO NOT unplug it. Do not open the door, change the damper setting or tamper with any controls on the stove.** Wait until smoke inside the firebox clears and blowers shut down. Do as instructed in “**PRE-START-UP CHECK**” and “**LIGHTING PROCEDURE**”, then attempt to restart the fire. If the problem persists, contact your dealer. Please note that smoke build-up during ignition may occur. Smoke can accumulate in the firebox for a few seconds just before the igniter is hot enough to fire-up the pellets in the burn pot. This is normal. As soon there is fire in the burn pot, smoke will disappear.
- b. **DO NOT STORE OR USE FLAMMABLE LIQUIDS, ESPECIALLY GASOLINE, IN THE VICINITY OF YOUR DROLET STOVE. NEVER USE A GAS OR PROPANE TORCH, GASOLINE, GASOLINE-TYPE LANTERN FUEL, KEROSENE, CHARCOAL LIGHTER FLUID OR SIMILAR FLUIDS TO START OR “FRESHEN UP” A FIRE IN THIS HEATER.**
- c. **WARNING: DO NOT OVERFIRE THIS STOVE.** This may cause serious damage to your stove and void your warranty. It also may create a fire hazard in your home. **IF ANY EXTERNAL PART OF THE UNIT BEGINS TO GLOW, YOU ARE OVERFIRING.** Immediately press the “MODE” switch on the control panel, until reaching the ‘OFF’ position. **DO NOT UNPLUG YOUR STOVE.** If you leave your house and your stove is not connected to a thermostat or a fresh air supply, do not leave it at the maximum setting. If the ambient air in a confined room becomes too hot, the stove may overheat and the thermal protection on the combustion/exhaust motor may be activated, causing the motor to stop.
- d. **KEEP ALL LOOSE OR MOVEABLE HOUSEHOLD COMBUSTIBLES, SUCH AS FURNITURE, DRAPES, TOYS, ETC. AT LEAST THREE FEET FROM THE OPERATING STOVE.**
- e. Maintain proper ventilation. It is important that adequate oxygen be supplied to the fire for the combustion process. Modern houses are often so well insulated that it may become necessary to open a window slightly or install an outside air vent to provide sufficient combustion air.
- f. Since heating with solid fuel is potentially hazardous, even with a well made and thoroughly tested stove, it would be wise to install strategically placed smoke detectors and have a fire extinguisher in a convenient location, near an exit.
- g. Do not open the stove door when operating unless necessary. This will create a dirty, inefficient burn and could allow smoke spillage or sparks to escape.
- h. Do not permit operation by young children or those unfamiliar with stove’s operation.
- i. **Do not service or clean this appliance without disconnecting the power cord.**
- j. Do not abuse the door glass by striking, slamming or similar trauma. Do not operate the stove with the glass removed, cracked or broken.
- k. If the stove is installed in a room without air conditioning, or in an area where direct sunlight can shine on the unit, it is possible this can cause the temperature of the stove to rise to operational levels; one of the sensors could then make the blowers start on their own. It is recommended that the stove be unplugged when not in use for extended periods of time (i.e. during the summer months).

FAILURE TO CLEAN AND MAINTAIN THIS UNIT AS INDICATED CAN RESULT IN POOR PERFORMANCE AND SAFETY HAZARDS. NEVER CLEAN WHEN HOT.

NOTE: Inspect burn pot periodically to see that holes have not become plugged. If so, clean thoroughly.

ASH REMOVAL

Ashes should be placed in a metal container with a tight-fitting lid. The closed container or ashes should be placed on a noncombustible surface or on the ground, well away from all combustible materials pending final disposal. If ashes are disposed of by soil burial or otherwise locally dispersed, they should be retained in the closed container until all cinders have thoroughly cooled.

ASH DISPOSAL

The ECO-45 has an ash bin located below the firebox. To remove ashes:

- Make sure fire is out and the firebox is cool.
 - Open the door and remove the baffle from the firebox. Close the door.
 - With the door closed, clean heat exchanger tubes by activating the cleaning rod back and forth from front to back. (see Cleaning section and Figure 18 & 19) .
 - Open the door and remove the burn pot by grasping it and pulling straight out. Scrape the burn pot with a scraper if necessary. Make sure that the burn pot holes are not plugged. Empty ashes from the burn pot into the pedestal ash bin through the opening at the bottom of the firebox. Put the burn pot back in place. Make sure it is level and pushed all the way in.
 - Scrape the ashes in the firebox into the pedestal ash bin through the opening or the bottom of the firebox or vacuum to remove ashes.
- WARNING: Make sure ashes are cool to the touch before using a vacuum. See "VACUUM USE".**
- Periodically remove and empty the ash bin (see Figure 20) by opening the front lid of the pedestal below the ash lip. Dispose of ashes properly. (See "**ASH REMOVAL**" above)
 - Put the ash bin back into place, making sure that you tighten the knob and maintain a good seal. Inspect gasket at the same time to make sure it is in good condition.

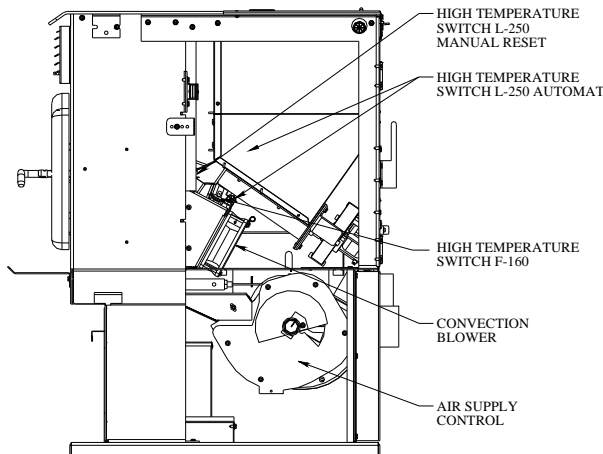

FIGURE 21
Side view

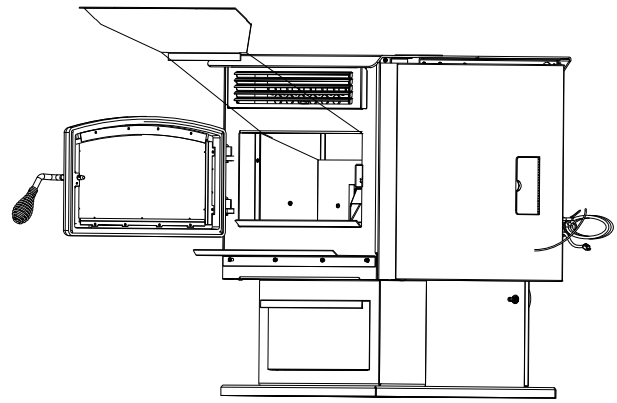

FIGURE 18
Baffle removal

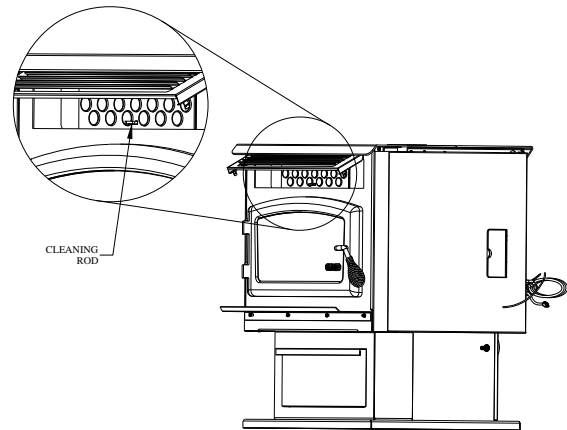

FIGURE 19
Cleaning rod

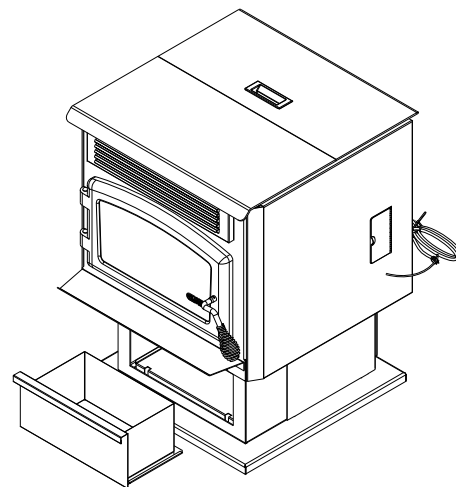

FIGURE 20
Ash drawer

VACCUM USE

If a vacuum is used to clean your stove, we suggest using a vacuum designed for ashes.

Some regular vacuums and shop vacs leak ash into the room. Your vacuum or shop vac may have a special filter or bag available to eliminate this leakage.

CLEANING

- a. **Heat Exchange Tubes** – Your ECO-45 stove is designed with a build-in heat exchanger tube cleaner. This should be used weekly to remove accumulated ash on the tubes. To clean the heat exchanger, open the door and grab the cleaning rod located behind the louvers (just above the stove's door) and push it forward. Close the door. Slide the cleaning rod back and forth two or three times from front to back (refer to figure 19). When finished, push the cleaning rod back in, behind the louvers.
- b. **Baffle:** Remove the baffle and scrape off ashes. Use a vacuum if necessary. In some cases, you will need to remove creosote on the baffle, which can accumulate rapidly under certain conditions. A small wire brush can be used. It is important to remove this creosote because it is highly combustible and could cause premature corrosion.
- c. **Chamber walls:** Periodically, you must vacuum the ashes that may have accumulated on the main walls of the combustion chamber. **START BY REMOVING THE DECORATIVE MASONRY-LIKE PANELS, WHICH ARE SIMPLY HELD BY SCREWS.** Scrape off ashes. Use a vacuum if necessary. There is also a cleaning outlet located behind the left side panel of the combustion chamber. Remove this panel using a screw driver. You will notice a small rectangular cleaning outlet. Inspect behind this outlet (see figure 22) Insert the vacuum tip through the cleaning outlet and clean thoroughly. **REPEAT THIS OPERATION AT LEAST ONCE PER TON OF PELLETS BURNED UNTIL YOU ARE FAMILIAR WITH HOW ASHES ACCUMULATE WITH YOUR OPERATING PRACTICES.**

BLOWERS

DANGER: RISK OF ELECTRIC SHOCK. DISCONNECT POWER BEFORE SERVICING UNIT.

- **Cleaning** – Over a period of time, ashes or dust may collect on the blades of both the combustion/exhaust blower and convection blower. Periodically, the blowers should be cleaned as the ash and dust can impede performance. The combustion/exhaust blower can be accessed by opening the left, right, and back panels located on the pedestal. To clean the blades in the combustion housing, insert the vacuum tip through the air inlet damper opening located on the side of the combustion housing. Clean thoroughly. To clean the blades in the exhaust housing, use a screw driver to remove the cleaning access panel located on the side of the metal box covering the housing. Insert the vacuum tip through the cleaning outlet and clean the blades thoroughly.

NOTE: When cleaning, be careful not to bend fan blades. Some stove owners lightly spray an anti-creosote chemical on the fire to help reduce creosote formation within the stove.

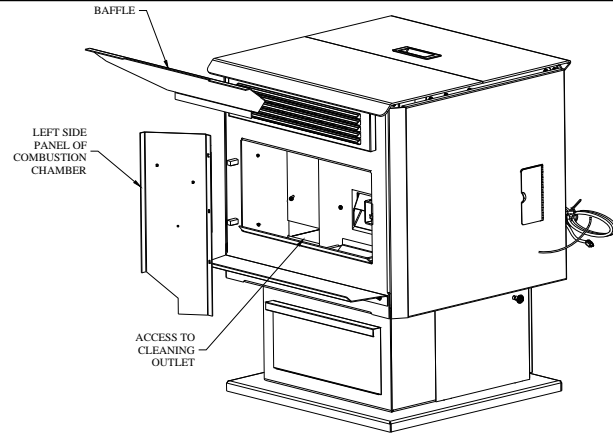

FIGURE 22
Access to cleaning outlet #1

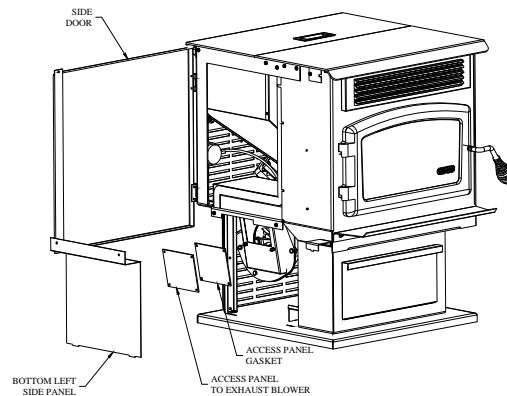

FIGURE 23
Access to cleaning outlet #2

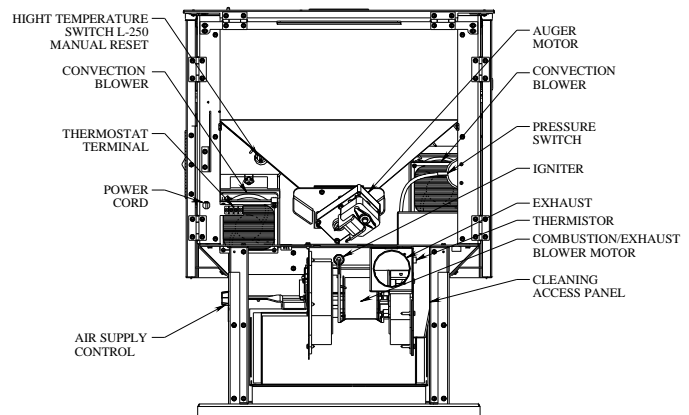

FIGURE 24
Rear view

Oiling – both the convection and combustion/exhaust blowers have sleeve bearings that are permanently sealed. No oiling is required.

CHIMNEY CLEANING

- a. **Creosote Formation** – When any wood is burned slowly, it produces tar and other organic vapors, which combine with expelled moisture to form creosote. The creosote vapors condense in the relatively cool chimney flue or a newly started fire or from a slow-burning fire. As a result, creosote residue accumulates on the flue lining. When ignited, this creosote makes an extremely hot fire, which may damage the chimney or even destroy the house. Despite their high efficiency, pellet stoves can accumulate creosote under certain conditions.
- b. **Fly Ash** – This accumulates in the horizontal portion of an exhaust run. Though noncombustible, it may impede the normal exhaust flow. It should therefore be periodically removed.
- c. **Inspection and Removal** – The chimney connector and chimney should be inspected annually or per ton to determine if a creosote or fly ash build-up has occurred. If creosote has accumulated, it should be removed to reduce the risk of a chimney fire. Inspect the system at the stove connection and at the chimney top. Cooler surfaces tend to build creosote deposits quicker, so it is important to check the chimney from the top as well as from the bottom.

The creosote should be removed with a brush specifically designed for the type of chimney in use. A qualified chimney sweep can perform this service. It is also recommended that before each heating season the entire system be professionally inspected, cleaned and, if necessary, repaired.

To clean the chimney, detach the vent at the combustion blower transition where it is attached to the blower.

RECOMMENDED MAINTENANCE SCHEDULE

Use this as a guide under average-use conditions.

| Components | Daily | Weekly or after +/- 10 bags | Twice a year or after +/- 25 bags | Annually or per ton of pellets |
|---------------------------|---|----------------------------------|-----------------------------------|--------------------------------|
| Burn Pot | Empty | Empty / Brush | | |
| Glass | Wipe | Clean | | |
| Heat Exchanger Tubes | Activate cleaning rod every time you load the stove | Activate cleaning rod and vacuum | | |
| Baffle | | Empty and brush | | |
| Convection Blower Filters | | Vacuum | | |
| Ashe Drawer | | Empty | | |
| Combustion Chamber | | Vacuum | Vacuum / Brush | |
| Left-hand Channel | | | Vacuum | |
| Exhaust Blower | | | Vacuum | |
| Pressure Switch Tap | | | Brush | |
| Venting System | | | Inspect | Sweep |
| Gaskets | | | Inspect | |
| Hopper | | | | Empty / Vacuum |

Gasket around door and door glass should be inspected and repaired or replaced when necessary (see “REPLACEMENT PARTS”).

REMOVAL AND REPLACEMENT OF BROKEN DOOR GLASS

While wearing leather gloves (or any other gloves suitable for handling broken glass), carefully remove any loose pieces of glass from the door frame. Dispose of all broken glass properly. Return the damaged glass to your Drolet Dealer for replacement. It is absolutely critical that you replace the glass with a genuine one supplied by your dealer.

MOTOR OILING

Both the convection and combustion/exhaust blowers have sleeve bearings that are permanently sealed. No oiling is required.

When your stove acts out of the ordinary, the first reaction is to call for help. This guide may save time and money by enabling you to solve simple problems yourself. Problems can be caused by to only five factors: 1) poor fuel; 2) poor operation or maintenance; 3) poor installation; 4) component failure; 5) factory defect. You can usually solve those problems related to 1 and 2. Your dealer can solve problems relating to 3, 4 and 5. Refer to figures 25 - 27 to help locate indicated parts.

Should you need to contact your dealer or the manufacturer, please photocopy and fill out the form in Appendix B. Try to answer as many questions as you can. Have it handy when you call. This will help you obtain a much faster service.



|  | |
|--|--|
| STOVE SHUTS OFF AND APPEARS ON CONTROL BOARD | |
| <u>Possible Causes:</u> | <u>Possible Remedies:</u> (Unplug stove first when possible) |
| 1. Airflow pressure switch hose or pressure tab for hose are blocked. | Unhook air hose from the airflow switch and blow through it. If air flows freely, the hose and tube are fine. If air will not flow through the hose, use a thin wire to clear the blockage. |
| 2. The air inlet, burn pot, interior combustion air chambers, combustion blower, or exhaust pipe are blocked with ash or foreign material. | Follow all cleaning procedures in the maintenance section of the owner's manual. |
| 3. Vent pipe is incorrectly installed. | Check to make sure vent pipe installation meets criteria in owner's manual and pipe manufacturer. |
| 4. The airflow pressure switch wire connections are faulty. | Check the connectors that attach to the airflow pressure switch. |
| 5. The airflow pressure switch wires are pulled loose at the connector on the wiring harness. | Check to see if the wires are loose at the connector. |
| 6. Combustion/exhaust blower failure. | With the stove on, check to see if the combustion/exhaust blower is running. If it is not, you will need to check for power going to the combustion/exhaust blower. Current reading may vary. If there is power, the blower is bad. If there is not, see #7. |
| 7. Control board not sending power to combustion/exhaust blower. | If there is no current going to the combustion blower, check all wire connections. If all wires are properly connected, you have a bad control board. |
| 8. Control board not sending power to airflow pressure switch. | There should be a 120-volt current going to the air switch after the stove has been on. You will need a technician to perform this test. |
| 9. Airflow pressure switch has failed (very rare). | To test the airflow pressure switch, you will need to disconnect the air hose from the body of the stove. With the other end still attached to the switch, very gently suck on the loose end of the hose (you may want to remove the hose entirely off the stove and the switch first and make sure it is clear). If you hear a click, the switch is working. BE CAREFUL TOO MUCH VACUUM CAN DAMAGE THE SWITCH. |

| STOVE SHUTS OFF AND  APPEARS ON THE CONTROL BOARD | |
|--|--|
| <u>Possible Causes:</u> | <u>Possible Remedies:</u> (Unplug stove first when possible) |
| 1. The hopper is out of pellets. | Refill the hopper. |
| 2. The air damper is too far open for a low feed setting. | If burning on the low setting, you may need to close the damper all the way turn the air supply knob toward the minimum setting. |
| 3. The burn pot holes are blocked. | Remove the burn pot and clean it thoroughly. |
| 4. The air inlet, the interior chambers, or exhaust system has a partial blockage. | Follow all cleaning procedures in the maintenance section of the owner's manual. |
| 5. The auger motor has failed. | Remove the auger motor from the auger shaft and try to run the motor separately by pressing the fuel feed button on the control board. If the motor turns, the shaft is jammed on something. If the motor does not turn, the motor is bad or a connection with the control board is faulty. To remove the auger motor, take off the top and bottom panels at the back of the stove's body. Loosen the two screws holding the motor to the auger shaft. Then, remove the plate located on the stove body, at the bottom of the gear motor, to allow the motor to slide out of the stove body. |
| 6. The auger shaft is jammed. | Remove that auger shaft from the auger housing. Start by emptying the hopper. Take off the top and bottom panels at the back of the stove's body. Then, remove the auger motor by removing the screws holding the motor to the auger shaft. Remove the plate located on the stove body, at the bottom of the gear motor, to allow the motor to slide out of the stove body. Once, the motor is out, remove the four screws on the steel plate holding the auger shaft to the auger housing. Then, rotate the bottom end of the auger shaft down towards you until you can pull the shaft down out of the stove. After you have removed the shaft, inspect it for bent flights, burrs, or broken welds. Remove any foreign material that might have caused the jam. Also, check the auger housing for signs of damage such as burrs, rough spots, or grooves cut into the metal that could have caused a jam. Clean the auger housing thoroughly to remove all pellet dust. |
| 7. The thermistor heat sensor has malfunctioned. | The thermistor is a heat sensor located on the exhaust housing. Its function is to tell the control board that the unit has ignited properly by measuring the heat in the exhaust. The pellet stove will not start feeding pellets at the desired heat setting until it has received a signal from the thermistor heat sensor. If the thermistor heat sensor is bad, the unit will stop after the ignition cycle. If this situation occurs, call your dealer or technician. |

| STOVE FEEDS PELLETS, BUT WILL NOT IGNITE AND  APPEARS ON THE CONTROL BOARD | |
|---|---|
| <u>Possible Causes:</u> | <u>Possible Remedies:</u> |
| 1. Air damper open too far for ignition. | Turn the air supply knob toward the minimum setting for startup. In some situations, it may be necessary to have the damper completely closed for ignition to take place. After there is a flame, the damper can then be adjusted for the desired feed setting. |
| 2. Blockage in igniter tube or inlet for igniter tube. | Remove the burn pot and clean it thoroughly. Make sure that all openings are clear. Find the igniter tube coming out of the burn pot housing. It is a small tube located on the back of the burn pot housing. Make sure it is clear. Make sure there is not any debris around the igniter element or inside the igniter tube. |
| 3. Bad igniter element. | Put power directly to the igniter element. Watch the tip of the igniter from the front of the stove. After about 2 minutes, the tip should glow. If it does not, the element is bad. You may need a technician to perform this test. |
| 4. The thermistor heat sensor has malfunctioned. | The thermistor is a heat sensor located on the exhaust housing. Its function is to tell the control board that the unit has ignited properly by measuring the heat in the exhaust. The pellet stove will not start feeding pellets at the desired heat setting until it has received a signal from the thermistor heat sensor. If the thermistor heat sensor is bad, the unit will stop after the ignition cycle. If this situation occurs, call your dealer or technician. |
| 5. The control board is not sending power to the igniter. | Check the voltage going to the igniter during startup. It should be a full current. If the voltage is lower than full current, check the wiring. If the wiring checks out good, the board is bad. You will need a technician to perform this test. |

| STOVE FEEDS PELLETS, BUT WILL NOT IGNITE AND  APPEARS ON THE CONTROL BOARD | |
|---|---|
| <u>Possible Causes:</u> | <u>Possible Remedies:</u> |
| 1. The igniter fuse on the control board has blown. | Remove the control board and check at the back to see if the F3 fuse appears to be bad. Replace it with a 5 Amp 250V fuse. Plug the stove back and try to run the unit. |

| STOVE STOPS FEEDING PELLETS AND  APPEARS ON THE CONTROL BOARD | |
|--|--|
| <u>Possible Causes:</u> | <u>Possible Remedies:</u> |
| 1. The L-250 manual reset high temperature switch has tripped. | Using the owner's manual, locate the L-250 high temperature switch. There is a red button located on the back of it. Press the red button. If you hear a click, the high limit had tripped. Reset the stove. The stove should now function normally. YOU NEED TO INSPECT YOUR UNIT AT THIS POINT. The F-250 high temperature switch will trip if the unit overheats. There might be a problem with another component or the installation, causing the stove to overheat. Make sure that the convection blower works. If the convection blower has failed, this can cause the unit to overheat. Clean any dust off of the windings and blades of the convection blower. Call your dealer or a technician if you get this code again. |

| | | |
|---|--|--|
|  STOVE STOPS FEEDING PELLETS AND APPEARS ON THE CONTROL BOARD | | |
| Possible Causes: | | Possible Remedies: |
| 1. One of the two L-250 automatic high temperature switches has been tripped. | | The L-250 automatic high temperature switch is located on the auger housing and will send a signal to the control board if the auger housing overheats. Wait until the stove cools down. YOU NEED TO INSPECT YOUR UNIT AT THIS POINT. There might be a problem with another component or the installation, causing the stove to overheat. Reset the stove and start it. Call a technician if you get this code again. |
| CODE | BEFORE RESETTING | TO RESET |
| H1, H2, H3 OR H4 | Heat exchanger and/or exhaust system is/are clogged. Refer to the owner's manual for maintenance procedures. | Press simultaneously for 2 seconds  and  . |
| *** After 3 attempts, reset is no longer possible, call SBI technical support. | | |

| | | |
|---|--|--|
|  STOVE STOPS FEEDING PELLETS AND APPEARS ON THE CONTROL BOARD | | |
| Possible Causes: | | Possible Remedies: |
| 1. The hopper lid has stayed open for more than 3 minutes | | As a security measure, the auger will stop turning and feeding pellets as soon as the hopper lid opens. It will resume normal operation as soon as the hopper lid is closed. However, if the hopper lid stays open for more than 3 minutes, the unit will stop and a code "d" will appear on the control board. Close the hopper lid. Reset the unit and start it again. |

| | | |
|--|--|--|
| SMOKE SMELL COMING BACK INTO THE HOME | | |
| Possible Causes: | | Possible Remedies: |
| 1. There is a leak in the vent pipe system. | | Inspect all vent pipe connections. Make sure they are sealed with RTV silicone that has a temperature rating on 500°F or higher. Also, seal joints with UL-181-AP foil tape. |
| 2. The gasket on the combustion/exhaust blower housing has gone bad. | | Inspect the gasket on the combustion/exhaust blower housing to make sure it is in good shape. |

| | | |
|--|--|--|
| AUGER MOTOR STOP FEEDING PELLETS AND COMES BACK ON | | |
| Possible Causes: | | Possible Remedies: |
| 1. The auger motor is overheating and tripping the internal temperature shutoff (thermal protector). | | Start by emptying the hopper. Then, remove the auger motor by removing the screws holding the motor to the auger shaft. Remove the plate located on the stove body, at the bottom of the gear motor, to allow the motor to slide out of the stove body. Once, the motor is out, remove the four screws on the steel plate holding the auger shaft to the auger housing. Then, rotate the bottom end of the auger shaft down towards you until you can pull the shaft down out of the stove. After you have removed the shaft, inspect it for bent flights, burrs, or broken welds. Remove any foreign material that might have caused the jam. Also, check the auger housing for signs of damage such as burrs, rough spots, or grooves cut into the metal that could have caused a jam. Clean the auger housing thoroughly to remove all pellet dust. |

| | |
|--|---|
| <ul style="list-style-type: none"> • GLASS “SOOT’S” UP AT A VERY FAST RATE • FLAME IS LAZY, DARK, AND HAS BLACK TIPS • AFTER STOVE HAS BEEN ON FOR A WHILE, THE BURNPOT OVERFILLS | |
| <u>Possible Causes:</u> | <u>Possible Remedies:</u> |
| 1. Stove or vent pipe is dirty, which restricts airflow through the burn pot. | Follow all cleaning procedure in the maintenance section of the owner's manual. |
| 2. Vent pipe installed improperly. | Check to make sure the vent pipe has been installed according to the criteria in the owner's manual. |
| 3. The air damper is too far closed for a higher setting. | Turn the air supply knob toward the maximum setting and try to burn the unit again. |
| 4. Burn pot holes are blocked. | Remove the burn pot and clean it thoroughly. |
| 5. Blockage in air intake pipe. | Visually inspect the air intake pipe that leads into the burn pot for foreign material. |
| 6. Combustion/exhaust blower is not spinning fast enough. | Test the RPM on the blower (separately – bypassing the control board) after the blades have been cleaned. The RPM should be approximately 3000 RPM. You will need a technician to perform this test. |
| 7. Bad pellets (Applies to “GLASS SOOTS UP AT A VERY FAST RATE” Only) | The brand of pellets or the batch of pellets that are being used may be of poor quality. If possible, try a different brand of pellets. You might also want to try a brand that is made from a different type of wood (softwood vs. hardwood). Different woods have different characteristics when being burned. Your pellets may also be too humid. Make sure your store your fuel properly, in a dry ventilated area. |

| | |
|---|--|
| <ul style="list-style-type: none"> • The control board does not display any information. | |
| <u>Possible Causes:</u> | <u>Possible Remedies :</u> |
| 1. A fuse on the control board has blown. | Remove the control board. Check if the F2 fuse on the back of it appears to be bad. Replace it with a 7.5 Amp 250 Volt fuse. Plug the stove back in and try to run the unit. |

| | | |
|---|---|--|
| THE STOVE IS RUNNING BUT DISPLAYS WARNING CODE |  | |
| <u>Possibles Causes:</u> | <u>Possibles Solutions:</u> | |
| Warning generated by a power failure while the stove was running. | The stove will restart on the initial setting once it cools off. Note: For a short power failure (less than 5 seconds), the stove will continue to function at the selected speed. | |

| MESSAGE | | CORRESPONDING WARNING |
|---------|--|---|
| P | | Pressure switch warning. |
| H | | L-250 automatic high temperature switch, located under the auger. |
| O | | L-250 manual reset high temperature switch, located beside convection blower. |
| E | | Hopper is empty |
| L | | Lighting warning. |
| d | | Hopper lid stay open more than 3 minutes. |
| n | | Inverted polarity in power outlet. |
| C | | Power outage |
| I | | Igniter fuse blew up |

SMOKE SMELL OR SOOT BUILD-UP

Because it is a wood-burning device, your ECO-45 may emit a faint wood-burning odor. If this increases beyond normal, or if you notice an unusual soot build-up on walls or furniture, check your exhaust system carefully for leaks. All joints should be properly sealed. Also clean your stove, following instructions in **"MAINTENANCE"**. If problem persists, contact your dealer.

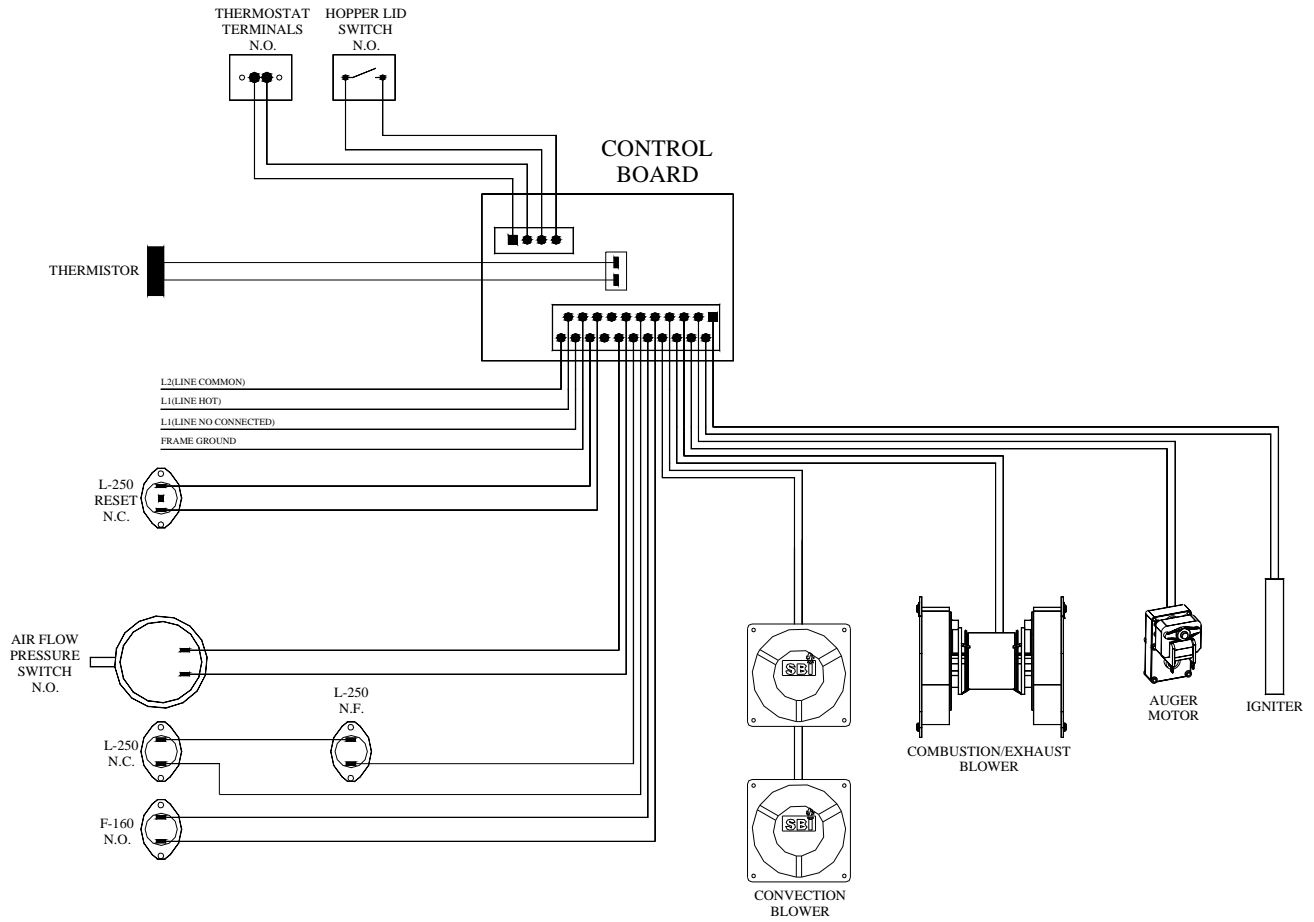

FIGURE 25

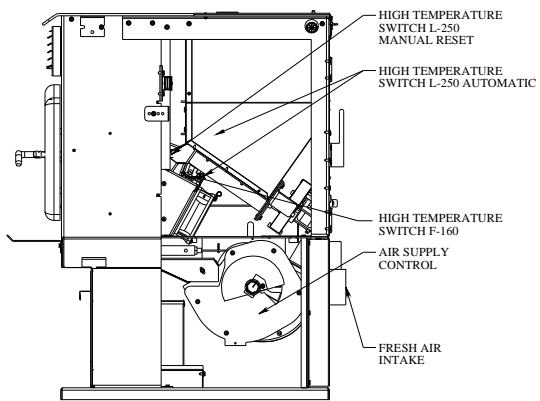

FIGURE 26

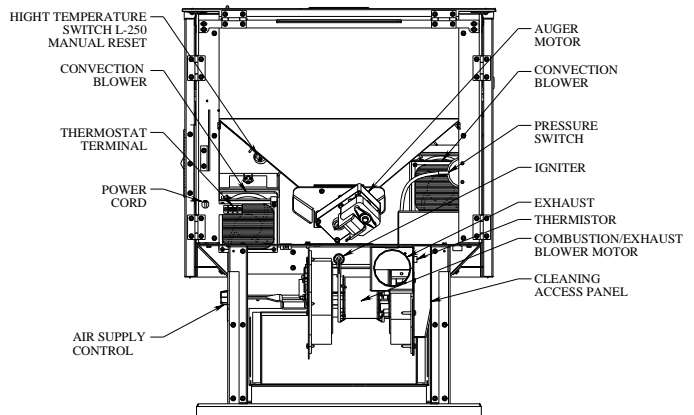

FIGURE 27

Contact an Authorized Drolet Dealer to obtain any of these parts. Never use substitute materials. Use of non-approved parts can result in poor performance and safety hazards.

| ITEM | PART # |
|--------------------------------------|---------|
| Airflow Pressure Switch | 44029 |
| Air Switch Hose | 49004 |
| Auger Motor | 44038 |
| Burn Pot | PL52545 |
| Control Board | 44032 |
| Combustion/Exhaust Blower Assembly | 44039 |
| Tubeaxial Convection Blower (2) | 44100 |
| Door Gasket | AC06100 |
| Door Glass | SE52708 |
| Log support | PL52691 |
| Exhaust Adapter 3" | SE52572 |
| Hot Rod Igniter | 44030 |
| Thermistor | 44095 |
| F-160 Convection blower heat sensor | 44058 |
| L-250 Automatic High Temp. Switch | 44059 |
| L-250 Manual Reset High Temp. Switch | 44041 |
| Window Gasket (7') | AC06400 |
| Convection blower gasket | 21107 |
| Combustion/Exhaust blower gasket | 21109 |
| Auger | 24017 |
| Loading lid switch | 44098 |
| Loading lid handle | 30527 |
| Ash drawer | SE52615 |
| Baffle | PL52628 |

HORIZONTAL AND VERTICAL VENT CHART

**Possible Vertical
vent length (feet)**

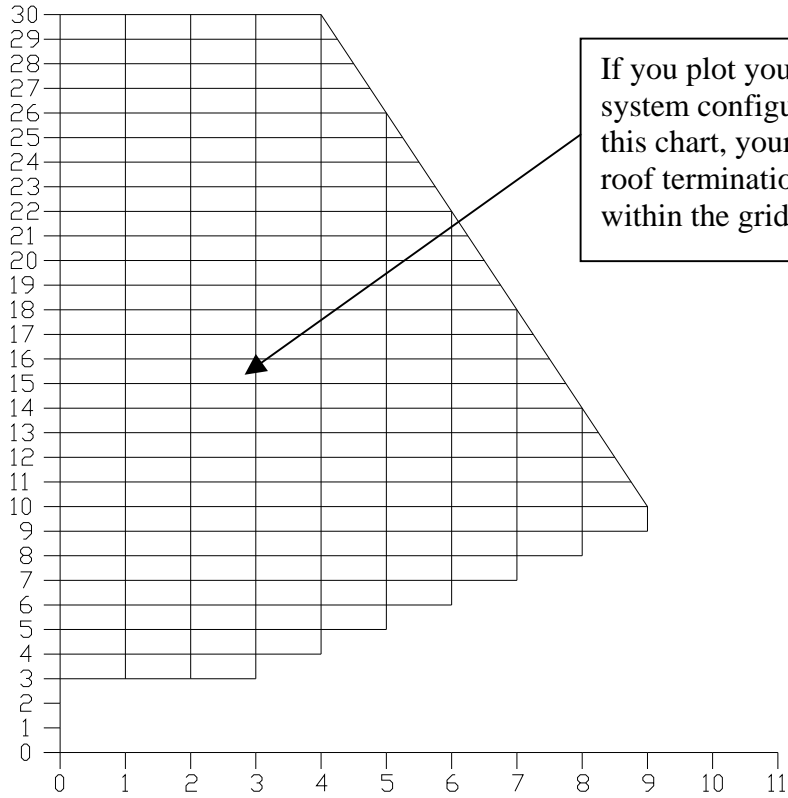

**Possible Horizontal
vent length (feet)**

Let's imagine an installation consisting of a horizontal vent coming out at the back of the stove on a total distance of 8 feet. This horizontal run is followed by a Tee and a 6-foot vertical rise. This type installation is not acceptable. As you can see, the vent termination is clearly outside the allowed configuration zone on the chart. The venting system does not have at least one foot of vertical rise for each foot of horizontal run.

Instead, if the installation consisted of a horizontal vent coming out at the back of the stove on a total distance of 4 feet, followed by a Tee and a 6-foot vertical rise, it would be acceptable. The installation would end within the allowable configuration zone on the chart since it would have at least one foot of vertical rise for each foot of horizontal run. Furthermore, the total vertical rise would be at least 3-foot high.



Fabriquant de poêle international inc.
 Stove Builder International Inc.
 1700, rue Léon-Harmel, Québec (Québec) G1N 4R9
 Phone : (418) 527-3060 Fax : (418) 527-4311
 E-mail : tech@sbi-international.com Web site : www.drolet.ca

INSTALLATION DIAGRAM

DRAW YOUR INSTALLATION
 1 SQUARE = 1 FOOT

Installation int. ext.

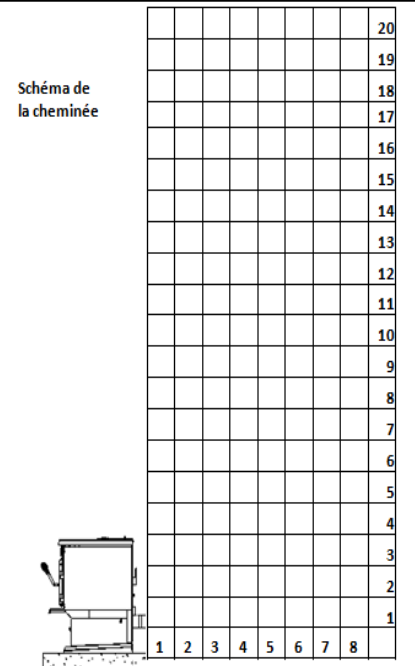

Equivalent vent lenght calculation table

Equivalent vent lenght (EVL)

CLEANING

| PART | DAILY | +/- 10 bags | +/- 25 bags | +/- 50 bags |
|--------------------------|--|--|--|--|
| Exchanger | <input type="checkbox"/> YES <input type="checkbox"/> NO | | | |
| Baffle | | <input type="checkbox"/> YES <input type="checkbox"/> NO | | |
| Left interior channel | | | <input type="checkbox"/> YES <input type="checkbox"/> NO | |
| Hopper | | | <input type="checkbox"/> YES <input type="checkbox"/> NO | |
| Evacuation blower | | | <input type="checkbox"/> YES <input type="checkbox"/> NO | |
| Blower blades | | | | <input type="checkbox"/> YES <input type="checkbox"/> NO |
| Pressure system | | | <input type="checkbox"/> YES <input type="checkbox"/> NO | |
| Burn pot | <input type="checkbox"/> YES <input type="checkbox"/> NO | | | |
| Convection blower filter | | <input type="checkbox"/> YES <input type="checkbox"/> NO | | |
| Evacuation system | | | <input type="checkbox"/> YES <input type="checkbox"/> NO | <input type="checkbox"/> YES <input type="checkbox"/> NO |
| Gaskets | | | <input type="checkbox"/> YES <input type="checkbox"/> NO | |

Use 4" pipe if you have more than 15 feet of Equivalent Vent Length (EVL).

The longer the run of pipe in your installation, the more restriction there is in the system. Therefore, larger diameter pipe should be used.

INDICATE APPLIANCE CODE

DESCRIPTION OF THE PROBLEM

Appliance code

| | | | | | |
|---|--------------------------|---|--------------------------|---|--------------------------|
| d | <input type="checkbox"/> | C | <input type="checkbox"/> | 0 | <input type="checkbox"/> |
| 1 | <input type="checkbox"/> | P | <input type="checkbox"/> | H | <input type="checkbox"/> |
| E | <input type="checkbox"/> | n | <input type="checkbox"/> | L | <input type="checkbox"/> |

INSPECTION AND REPAIR FORM

DROLET LIMITED LIFETIME WARRANTY

The warranty of the manufacturer extends only to the original consumer purchaser and is not transferable. This warranty covers brand new products only, which have not been altered, modified nor repaired since shipment from factory. Proof of purchase (dated bill of sale), model name and serial number must be supplied when making any warranty claim to your DROLET dealer.

This warranty applies to normal residential use only. Damages caused by misuse, abuse, improper installation, lack of maintenance, negligence or accident during transportation are not covered by this warranty.

This warranty does not cover any scratch, corrosion, warping, or discoloration caused by over firing, abrasives or chemical cleaners. Any defect or damage caused by the use of unauthorized parts or others than original parts void this warranty. An authorized qualified technician must perform the installation in accordance with the instructions supplied with this product and all local and national building codes. Any service call related to an improper installation is not covered by this warranty.

The manufacturer may require that defective products be returned or that digital pictures be provided to support the claim. Returned products are to be shipped prepaid to the manufacturer for investigation. If a product is found to be defective, the manufacturer will repair or replace such defect and reasonable transportation fees will be refunded. Repair work covered by the warranty, executed at the purchaser's domicile by an authorized qualified technician requires the prior approval of the manufacturer. Labour cost and repair work to the account of the manufacturer are based on predetermined rate schedule and must not exceed the wholesale price of the replacement part. All labour and freight costs covered by this warranty are limited according to the table below.

The manufacturer at its discretion may decide to repair or replace any part or unit after inspection and investigation of the defect. The manufacturer may, at its discretion, fully discharge all obligations with respect to this warranty by refunding the wholesale price of any warranted but defective parts. The manufacturer shall in no event be responsible for any special, indirect, consequential damages of any nature, which are in excess of the original purchase price of the product.

| DESCRIPTION | WARRANTY APPLICATION | |
|---|----------------------|---------|
| | PARTS | LABOUR |
| Combustion chamber (welds only), heat exchanger, auger, and castings. | Lifetime | 5 years |
| Plating (defective manufacture) – subject to limitations above | Lifetime | n/a |
| Convection blower, combustion blower, auger motor, and PC board | 2 years | 1 year |
| Stainless steel baffle and parts | 5 years | 3 years |
| Carbon steel baffle and parts | 2 years | 1 year |
| Ceramic glass (thermal breakage only*) | 2 years | n/a |
| Heat sensors, switches, and igniter. | 1 year | 1 year |
| Paint (peeling), ceramic logs, gaskets, and masonry-like panels | 1 year | n/a |

**Pictures required*

Shall your unit or a components be defective, contact immediately your **DROLET** dealer. Prior to your call make sure you have the following information necessary to your warranty claim treatment:

- Your name, address and telephone number;
- Bill of sale and dealer's name;
- Serial number and model name as indicated on the nameplate fixed to the back of your unit;
- Nature of the defect and any relevant information.

Before shipping your unit or defective component to our plant, you must obtain from your DROLET dealer an Authorization Number. Any merchandise shipped to our plant without authorization will be refused automatically and returned to sender.