

**CHELSEA<sup>®</sup>**

Bulletin HY25-1202-M1/US

# Owner's Manual Split Shaft and Gear Box

Effective: January 2005  
Supersedes: HY25-1202-M1/US  
April 2003

---

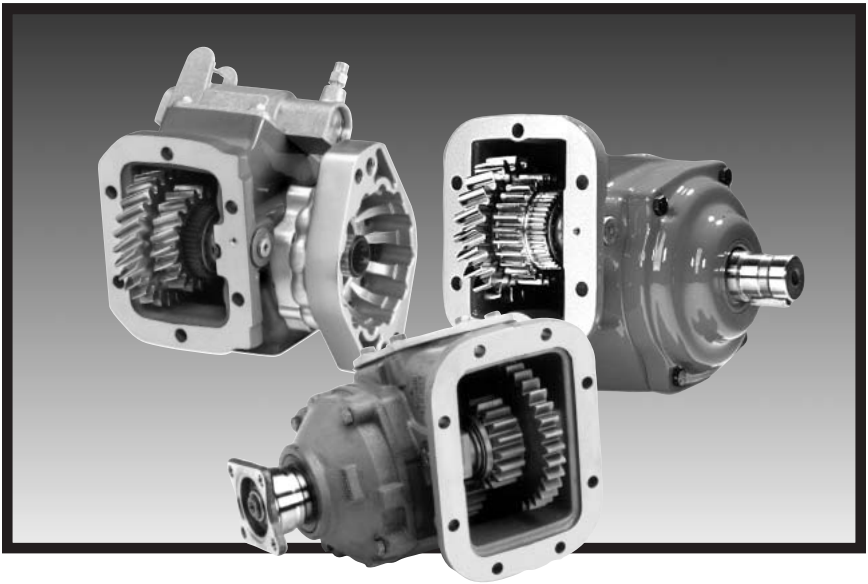

**700 Series  
712 Series  
721 Series  
732 Series**

**741 Series  
901 Series  
912 Series  
931 Series**

**941 Series  
2230 Series  
2442 Series**



---

 **WARNING**

FAILURE OR IMPROPER SELECTION OR IMPROPER USE OF THE PRODUCTS AND/OR SYSTEMS DESCRIBED HEREIN OR RELATED ITEMS CAN CAUSE DEATH, PERSONAL INJURY AND PROPERTY DAMAGE.

This document and other information from Parker Hannifin Corporation, its subsidiaries and authorized distributors provide product and/or system options for further investigation by users having technical expertise. It is important that you analyze all aspects of your application and review the information concerning the product or system in the current product catalog. Due to the variety of operating conditions and applications for these products or systems, the user, through its own analysis and testing, is solely responsible for making the final selection of the products and systems and assuring that all performance, safety and warning requirements of the application are met.

The products described herein, including without limitation, product features, specifications, designs, availability and pricing, are subject to change by Parker Hannifin Corporation and its subsidiaries at any time without notice.

**Offer of Sale**

The items described in this document are hereby offered for sale by Parker Hannifin Corporation, its subsidiaries or its authorized distributors. This offer and its acceptance are governed by the provisions stated in the "Offer of Sale".

**Patent Information**

The Chelsea® Power Take-Off or its components shipped with this owner's manual may be manufactured under one or more of the following U.S. patents:

4610175    5228355    4597301    5645363    6151975    6142274    6260682

Other patents pending.

© Copyright 2005, Parker Hannifin Corporation, All Rights Reserved

**Contents****General Information**

Safety Information .....	1-3
Direct Mount Pump Support Recommendations .....	4
Shifting Procedures .....	5
Foreword .....	6
Split Shaft and Gear Box Specifications .....	8
Horsepower-Torque-R.P.M. Conversion Chart .....	9

**Installation of a Split Shaft**

Application Data .....	10-11
Lubrication Information .....	12
Installation Instructions .....	13
Model 901 Installation Drawings .....	14
Model 901 Dimensional Drawings .....	15
Model 912 Installation Drawing .....	16
Model 912 Dimensional Drawing .....	17
Model 931 Installation Drawings .....	18
Model 931 Dimensional Drawings .....	19
Model 941 Installation Drawing .....	20
Model 941 Dimensional Drawing .....	21

**Installation of a Gear Box**

Installation Instructions .....	22
Models 700, 712, 721, 732, 741, 2230 and 2442	

**Breather Hose Installation** ..... 23**Installation of a P.T.O. to a Split Shaft**

Application Questions .....	24
Mounting Instructions—6 or 8 Bolt Applications .....	25-26
880/912 Split Shaft Installation .....	27

**Checking Backlash** ..... 28**Wire Shift P.T.O.'s and Gear Boxes**

Cable Control Installation Instructions .....	29-32
---	-------

**Air Shift Installation Sketch**

2442 Gear Box .....	33
901, 912, and 941 Split Shafts .....	34
Air Shift Circuit 2230 Series .....	35

**Dash Drilling Templates**

2442 Gear Box Air Shift Control .....	36
901, 912, and 941 Split Shafts Air Shift Control .....	37
Wire and Lever Controls .....	38
Indicator Light Installation .....	39

**Continuity Check** ..... 40**Troubleshooting** ..... 41-42**Power Take-Off Maintenance** ..... 43**Offer of Sale** ..... 44

## Safety Information

These instructions are for your safety and the safety of the end user. Read them carefully until you understand them.

### General Safety Information

#### To prevent injury to yourself and/or damage to the equipment:

- Read carefully all owner's manuals, service manuals, and/or other instructions.
- Always follow proper procedures, and use proper tools and safety equipment.
- Be sure to receive proper training.
- Never work alone while under a vehicle or while repairing or maintaining equipment.
- Always use proper components in applications for which they are approved.
- Be sure to assemble components properly.
- Never use wornout or damaged components.
- Always block any raised or moving device that may injure a person working on or under a vehicle.
- Never operate the controls of the Power Take-Off or other driven equipment from any position that could result in getting caught in the moving machinery.

#### Proper Matching of P.T.O.



**WARNING:** A Power Take-Off must be properly matched to the vehicle transmission and to the auxiliary equipment being powered. An improperly matched Power Take-Off could cause severe damage to the vehicle transmission, the auxiliary driveshaft, and/or to the auxiliary equipment being powered. **Damaged components or equipment could malfunction causing serious personal injury to the vehicle operator or to others nearby.**

#### To avoid personal injury and/or equipment damage:

- Always refer to Chelsea catalogs, literature, and owner's manuals and follow Chelsea recommendations when selecting, installing, repairing, or operating a Power Take-Off.
- Never attempt to use a Power Take-Off not specifically recommended by Chelsea for the vehicle transmission.
- Always match the Power Take-Off's specified output capabilities to the requirements of the equipment to be powered.
- Never use a Power Take-Off whose range of speed could exceed the maximum safe speed of the equipment to be powered.



This symbol warns of possible personal injury.

## Safety Information (Continued)

### Cold Weather Operation of Powershift P.T.O.s



**WARNING:** During extreme cold weather operation [32°F (0°C) and lower], a disengaged Powershift Power Take-Off can momentarily transmit high torque that will cause unexpected output shaft rotation. This is caused by the high viscosity of the transmission oil when it is extremely cold. As slippage occurs between the Power Take-Off clutch plates, the oil will rapidly heat up and the viscous drag will quickly decrease.

The Power Take-Off output shaft rotation could cause unexpected movement of the driven equipment resulting in serious personal injury, death, or equipment damage.

#### To avoid personal injury or equipment damage:

- Driven equipment must have separate controls.
- The driven equipment must be left in the disengaged position when not in operation.
- Do not operate the driven equipment until the vehicle is allowed to warm up.

### Rotating Auxiliary Driveshafts



**WARNING:**



- Rotating auxiliary driveshafts are dangerous. You can snag clothes, skin, hair, hands, etc. This can cause serious injury or death.
- Do not go under the vehicle when the engine is running.
- Do not work on or near an exposed shaft when the engine is running.
- Shut off the engine before working on the Power Take-Off or driven equipment.
- Exposed rotating driveshafts must be guarded.

### Guarding Auxiliary Driveshafts



**WARNING:** We strongly recommend that a Power Take-Off and a directly mounted pump be used to eliminate the auxiliary driveshaft whenever possible. If an auxiliary drive-shaft is used and remains exposed after installation, it is the responsibility of the vehicle designer and P.T.O. installer to install a guard.



This symbol warns of possible personal injury.

## Safety Information (Continued)

### Using Set Screws



**WARNING:** Auxiliary driveshafts may be installed with either recessed or protruding set screws. If you choose a square head set screw, you should be aware that it will protrude above the hub of the yoke and may be a point where clothes, skin, hair, hands, etc. could be snagged. A socket head set screw, which may not protrude above the hub of the yoke, does not permit the same amount of torquing as does a square head set screw. Also, a square head set screw, if used with a lock wire, will prevent loosening of the screw caused by vibration. Regardless of the choice made with respect to a set screw, an exposed rotating auxiliary driveshaft must be guarded.

### IMPORTANT: Safety Information and Owner's Manual

Chelsea Power Take-Offs are packaged with safety information decals, instructions, and an owner's manual. These items are located in the envelope with the P.T.O. mounting gaskets. Also, safety information and installation instructions are packaged with some individual parts and kits. **Be sure to read the owner's manual before installing or operating the P. T. O.** Always install the safety information decals according to the instructions provided. Place the owner's manual in the vehicle glove compartment.



### **WARNING: Operating the P.T.O. with the Vehicle in Motion**

Some Power Take-Offs may be operated when the vehicle is in motion. To do so, the P.T.O. must have been properly selected to operate at highway speeds and correctly matched to the vehicle transmission and the requirements of the driven equipment.

If in doubt about the P.T.O.s specifications and capabilities, avoid operating the P.T.O. when the vehicle is in motion. Improper application and/or operation can cause serious personal injury or premature failure of the vehicle, the driven equipment, and/or the P.T.O.

Always remember to disengage the P.T.O. when the driven equipment is not in operation.

### Pump Installation Precautions (see next page)

Use a bracket to support the pump to the transmission if:

- The pump weighs **40 pounds [18.14 kg]** or more.
- The combined length of the P.T.O. and pump is **18 inches [45.72 cm]** or more from the P.T.O. centerline to the end of the pump.



This symbol warns of possible personal injury.

## Direct Mount Pump Support Recommendations

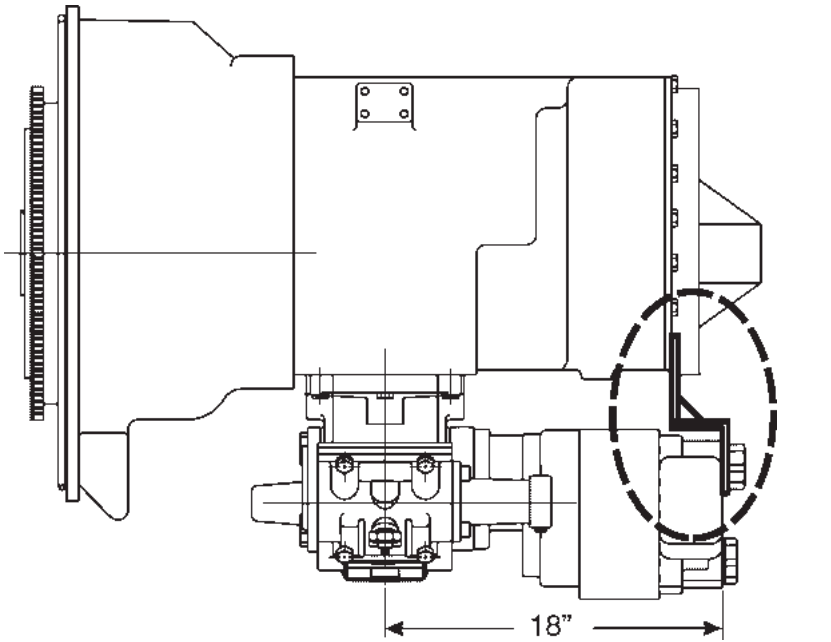

**Note:** For Proper Bracketing Attach At 2 or more Transmission Bolt Locations and 2 or More Pump Locations.

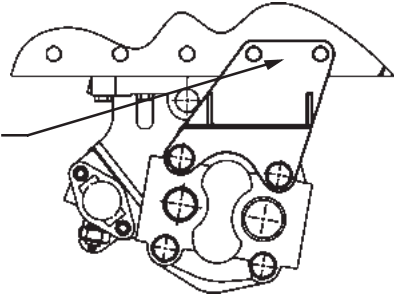

**⚠ Use caution to ensure that bracket does not pre-load pump/ P.T.O. mounting**

Chelsea strongly recommends the use of pump supports (Support Brackets) in all applications. P.T.O. warranty will be void if a pump bracket is not used when:

- 1) The combined weight of pump, fittings and hose exceed **40 pounds** [18.14 kg].
- 2) The combined length of the P.T.O. and pump is **18 inches** [45.72 cm] or more from the P.T.O. centerline to the end of the pump.

**ALSO:** Remember to pack the female pilot of the P.T.O. pump shaft with grease before installing the pump on the P.T.O. (reference Chelsea grease pack 379688)

**⚠ This symbol warns of possible personal injury.**

## **Shifting Procedures**

### **Gear Box Operation**

#### **Vehicle Stationary**

Before shifting the gear box into or out of gear, make sure the gears in the unit and input shaft have stopped rotating.

### **Split Shaft Operation**

#### **Manual Transmission—Vehicle Stationary**

##### **Road mode to P.T.O. mode:**

1. Disengage the clutch and stop the vehicle.
2. Engage the parking brakes.
3. Shift the split shaft to P.T.O. mode.
4. Select the desired transmission gear as required.
5. Engage the clutch.
6. Apply throttle as required.

##### **P.T.O. mode to road mode:**

1. Disengage the clutch.
2. Shift the split shaft to road mode.
3. Disengage the parking brakes.
4. Resume normal driving procedures.

#### **Automatic Transmission**

##### **Road mode to P.T.O. mode:**

1. Stop the vehicle.
2. Engage the parking brakes.
3. Shift the transmission into Neutral "N."
4. Shift the split shaft to P.T.O. mode.
5. Shift the transmission into the desired drive range position.
6. Apply throttle as required.

##### **P.T.O. mode to road mode:**

1. Shift the transmission into Neutral "N."
2. Shift the split shaft to road mode.
3. Release the parking brake.
4. Resume normal driving procedures.

**CAUTION: Inadvertent shift may cause vehicle movement or unexpected engagement of P.T.O.**



## Foreword

Since it is our major objective to show you how to get additional and more profitable miles from truck, tractor, and trailer components, we want to provide you with information on the installation of Chelsea Power Take-Offs.

We all realize that an inadequate Split Shaft will overwork any Power Take-Off in a very short period of time. In addition, a mismatched Split Shaft/P.T.O. combination can result in unsatisfactory performance of the equipment right from the start.

Before you order new trucks, be sure that you're getting the right Gear Box, Split Shaft or P.T.O. combination. This is vital for efficient performance and adequate power. To help you select the proper type, size, and design of P.T.O., discuss your specific requirements with a Chelsea P.T.O. specialist. They know their products and have easy access to equipment, transmission, and Power Take-Off manufacturers. They can tell you everything you need to know about power, at the right time, before you specify components.

## Chelsea P.T.O. Safety Label Instructions

1. The two black and orange on white 5" x 7" pressure sensitive vinyl labels, part number 379274; must be placed on the vehicle frame rails (one (1) on each side), in a position that would be HIGHLY visible to anyone that would go under the truck near the P.T.O. rotating shaft. If the vehicle is to be painted after these labels are installed, cover them with two-(2) blank masking covers. Remove the masking covers after painting.
2. Place the one (1) black and orange on white 3.5" x 5" pressure sensitive vinyl label, part number 379275, on the visor nearest the operator of the vehicle, this must be placed near the P.T.O. visor label.
3. Place the one (1) red and white with black lettering 3.5" x 7.5" sensitive vinyl label, part number 379915, on the opposite side of the visor from the above label # 379275.
4. Place the one (1) white and black heavy duty card, part number 379276, in the vehicle glove box. Again in a position highly visible to the operator, for example: try to place this card on top of whatever may be in the glove box.

If you require additional labels, please order part number 328946X at no charge from your local Chelsea Warehouse or send request direct to:

**Parker Hannifin Corporation**  
**Chelsea Products Division**  
**8225 Hacks Cross Road**  
**Olive Branch, MS 38654**  
**Customer Service: (662) 895-1011**



## Split Shaft and Gear Box Specifications

<b>Model No.</b>	<b>Horsepower at 500 R.P.M. 1000 R.P.M.</b>		<b>Intermittent Torque Rating P.T.O. Shaft</b>	<b>Approximate Weight</b>	<b>Lube Capacity</b>	<b>Liters</b>
700	11.9	23.5	125 ft. lbs.	39 lbs.	1.5 pt.	.7
Single Speed	10	20	110 ft. lbs.	39 lbs.	1.5 pt.	.7
712 Two Speed Shaft	11.9	23.5	125 ft. lbs.	39 lbs.	1.5 pt.	.7
721	13.2	26.5	140 ft. lbs.	49 lbs.	1.5 pt.	.7
732	13.2	26.5	140 ft. lbs.	49 lbs.	1.5 pt.	.7
741	13.2	26.5	140 ft. lbs.	49 lbs.	1.5 pt.	.7
2230U	21.4	42.8	225 ft. lbs.	88 lbs.	1.5 pt.	.7
2442F	23.5	47	250 ft. lbs.	69 lbs.	1.5 pt.	.7
2442L	23.5	47	250 ft. lbs.	69 lbs.	1.5 pt.	.7
2442Q	21.4	42.8	225 ft. lbs.	69 lbs.	1.5 pt.	.7
2442R	21.4	42.8	225 ft. lbs.	69 lbs.	1.5 pt.	.7
2442S	19	38	200 ft. lbs.	69 lbs.	1.5 pt.	.7
2442U	18.6	37.2	195 ft. lbs.	69 lbs.	1.5 pt.	.7
2442W	16.7	33.4	175 ft. lbs.	69 lbs.	1.5 pt.	.7
2442X	13.2	26.5	140 ft. lbs.	69 lbs.	1.5 pt.	.7
					2.5 qt. vertical	2.4
901•			500 ft. lbs.	185 lbs.	3.0 qt. horizontal	2.8
912•			*	130 lbs.	2.5 qt. less P.T.O.	2.4
931•			250 ft. lbs.	102 lbs.	2.25 qt.	2.175
941•			**	60 lbs.	2.25 pt.	

• For allowable split shaft input torque, please consult the chart [on page 11](#).

\* The 912 has 3 eight bolt P.T.O. openings on it. For correct P.T.O. applications please consult your HY25-3000/US catalog.

\*\*The 941 has 2 six bolt P.T.O. openings on it. For correct P.T.O. applications please consult your HY25-3000/US catalog.

## Horsepower-Torque-R.P.M. Conversion Chart

**To find the Torque.** Given: 100 HP at 1750 R.P.M.

Then: with a straight edge on HP scale at 100 (Left Side) and on R.P.M. scale at 1750.  
 Find Answer on T scale = 300 foot pounds torque (Middle).

$$\text{Formula: } \frac{\text{HP} \times 5252}{\text{R.P.M.}} = \text{T Foot Pounds Torque}$$

**To find the HP.** Given: 3 pounds feet torque at 1750 R.P.M.

Then: with a straight edge on the T scale at 3 (Middle) and on the R.P.M. scale at 1750.  
 Find Answer on the HP scale = 1 Horsepower (Left Side)

$$\text{Formula: } \frac{\text{T} \times \text{R.P.M.}}{5252} = \text{HP Horsepower}$$

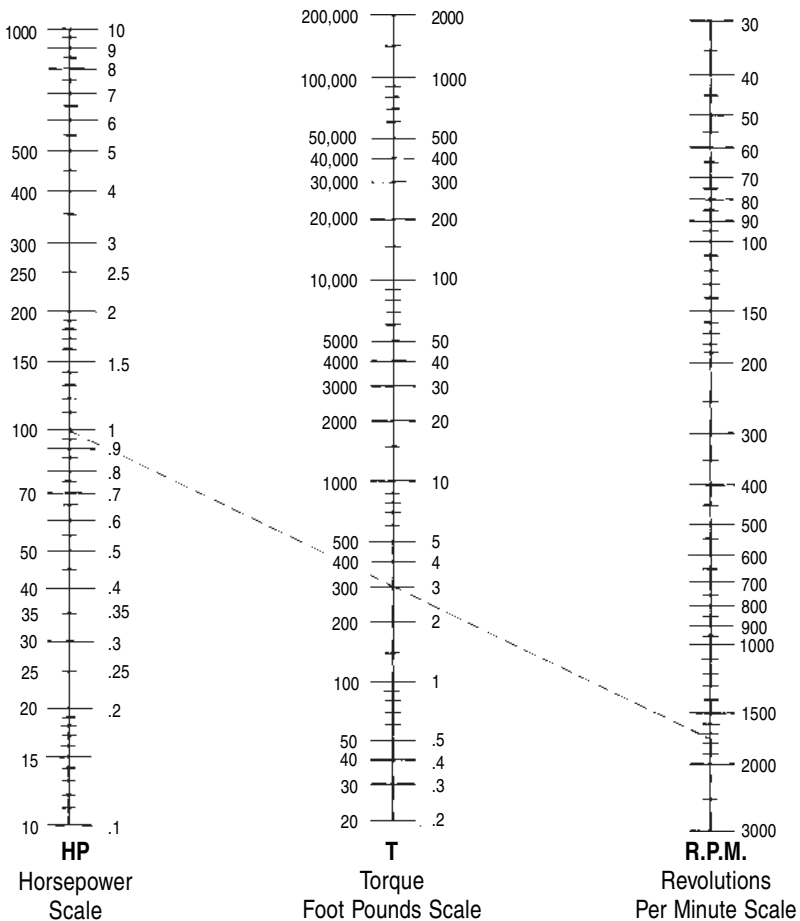

## Application Data for Installation of a Split Shaft

### Split Shaft Through Torque Ratings

The torque capacity of the Chelsea Split Shaft units is limited by either the engine capacity or the vehicle wheel skid conditions. To correctly choose a split shaft model for a given application, the maximum torque from the engine, and the maximum torque due to wheel conditions, should be calculated. The limiting value obtained by these calculations should then be compared with the charted split shaft torque capacity.

### Formula

#### Maximum Through Torque From the Engine

1. Maximum Torque From the Engine = Maximum Net Engine Torque X Manual Transmission Low Gear Ratio X 85% Efficiency
2. For an automatic transmission, the maximum torque from the engine should be taken from the engine-transmission performance curve stall torque value. This information is generally available from the manufacturer of the automatic transmission.

#### Maximum Torque Due to Wheel Skid Conditions

$$3. \quad \text{Maximum ft. lbs. of Torque} = \frac{\text{GVW} \times f \times \text{RAD}}{12 \times \text{AR}}$$

Where: GVW = maximum gross vehicle weight on the rear wheels only  
 f = coefficient of friction  
 RAD = tire loaded rolling radius (inches)  
 AR = axle ratio

Based on past experience, the coefficients of friction used have been:

- f = 0.8 for on-highway service (dry pavement)
- f = 0.5 for off-highway service

These are generally used values but if information is available for a specific application, the appropriate coefficient of friction can be used.

## Application Data for Installation of a Split Shaft

### Split Shaft Through Torque Capacity

Split Shaft Model	Shaft Outside Diameter	Maximum Nominal Torque Rating (ft. lbs.)			
		Diesel Engine		Gas Engine	
		Automatic Transmission	Manual Transmission	Automatic Transmission	Manual Transmission
901	1 3/4"	3,300	3,100	4,200	3,900
912	2 3/4"	13,000	2,000	16,000	15,000
931	1 3/8"	1,700	1,600	2,200	2,200
941	1 1/2"	3,100	2,900	4,200	3,900

### SERVICE FACTOR CHART

Duty	Vehicle Description	Service Factor
Extra Light	Light Vehicle on Highway	1.0
Light	Light Vehicle off Highway	1.1
Heavy	Heavy Vehicle on Highway	1.2
Extra Heavy	Heavy Vehicle off Highway	1.3

The allowable split shaft torque can be calculated using the above charted values and the following equation:

$$\text{Allowable Split Shaft Torque} = \frac{\text{Maximum Nominal Torque Rating}}{\text{Application Service Factor}}$$

## Lubrication Information

To insure proper lubrication and operating temperatures in these units, it is most important that the proper lubricants be used and that correct oil levels be maintained.

### Recommended Lubricants

The following lubricants are recommended, in order of preference, for use in all Chelsea Split Shafts and Gear Boxes.

### Models 700, 712, 721, 732, 741, 901, 912, 931, 941, 2230, and 2442

Temperature	Grade	Type
Above 0°F	S.A.E. 30, 40, or 50	Heavy Duty Engine Oil Meeting Spec
Below 0°F	S.A.E. 30	MIL-L-2104B or MIL-L-45199 Series 3
Above 0°F	S.A.E. 90	Straight Mineral Gear Oil
Below 0°F	S.A.E. 80	

**Do Not Use Extreme Pressure Additives**, such as found in multi-purpose or rear axle type lubricants. These additives are not required in our split shafts and gear boxes, and they may in some cases create transmission problems. Multi-purpose oils, as a group, have relatively poor oxidation stability, a high rate of sludge formation and a greater tendency to react on or corrode the steel and bronze parts.

### Oil Changes

We recommend an initial oil change and flush after the split shaft is placed in actual service. This change should be made any time following 1,000 miles, but never to exceed 4,000 miles, of over-the-road service. In off-highway use, the change should be made after 24 and before 100 hours of service have elapsed. There are many factors that influence the following oil change periods, and we have not specified a definite mileage interval.

In general, it is suggested that a drain and flush period be scheduled every 20,000 miles for normal over-the-highway operations. Off-the-highway usually requires an oil change every 30 days. The oil level in the split shaft should be checked every 2,000 miles on-highway, or every 24 hours in off-highway operation. When it is necessary to add oil, we recommend that types or brands of oil not be mixed. The correct oil level in all Chelsea Split Shafts is established by the filler plug opening.

**Refill**—First, remove all dirt around the filler plug. Then refill with new oil of a grade recommended for the existing season and prevailing service.

### Overfilling

Do not overfill the gear box or split shaft. Overfilling usually results in oil breakdown due to excessive heat and aeration from the churning action of the gears. Early breakdown of the oil will result in heavy varnish and sludge deposits that plug up oil ports and buildup on splines and bearings. Overflow of oil usually escapes onto clutch or parking brakes, causing additional trouble.

## Installation Instructions—Split Shaft

Split shaft Power Take-Offs are installed into the vehicle driveline. This requires cutting and reworking driveshafts. No attempt will be made here to list driveline fabrication or rework procedures. For answers to specific questions, contact the Drivetrain Service Division. Listed are the necessities for a good Power Take-Off installation that will run quietly and without vibration. The unit itself should be suspended from a rubber isolated crossmember and will replace the center bearing for the driveline. Grade 8 bolts should be used for all fastenings.

1. Front—a short coupled joint connecting the transmission to the split shaft should be installed so as to permit equal joint angles of less than 3°.

Rear—A two joint assembly connecting the split shaft to the rear axle should be installed so as to permit equal joint angles of less than 5° to insure the best performance. The joint angles should be kept within a minimum of 1° to 3°.

Front & Rear—the two joint assembly at the front and rear should be installed so as to permit equal joint angles of less than 5°.

2. Determine a suitable location for crossmembers for mounting the split shaft. Raise or lower or move the split shaft front or rear as required to reduce the joint angles to a minimum but not less than 1°.
3. Align the split shaft with the transmission and rear axle.
  - A. For the best installation and optimum performance, the input and output shafts of the split shaft should be parallel respectively within 1° to the main shaft of the transmission and the pinion shaft of the axle.
  - B. With the shafts parallel, the joint angles should be in one plane only. Make sure the offset in the horizontal or vertical planes will provide for equal joint angles of less than 3° with a short coupled joint or less than 5° with a two joint assembly.
4. Excessive angles result in a loss of speed and power. The figures shown below are approximate and any angle less than those shown will provide a better installation.

Speed	True Joint Operating Angle
5,000 R.P.M.	3° 15'
4,000 R.P.M.	4° 15'
3,000 R.P.M.	5° 50'

Slight angles of 1° in each joint are necessary for the circulation of the needles.

5. The front and rear shafts should be assembled, straightened, and balanced before installation.



## Model 901 Split Shaft Installation Drawings

### Vertical Mounting

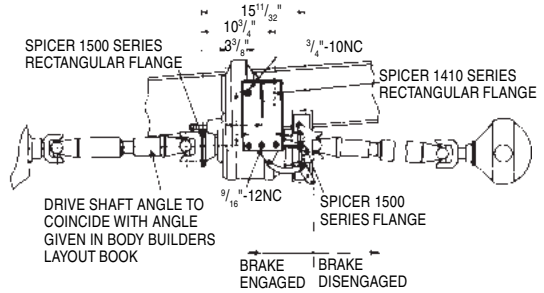
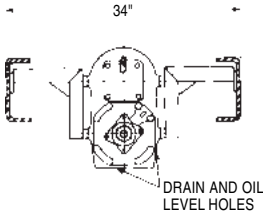

### Horizontal Mounting

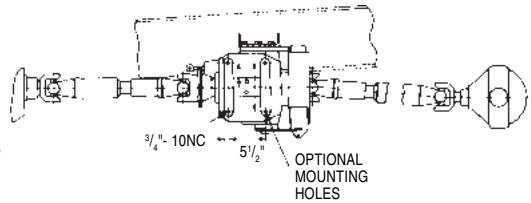
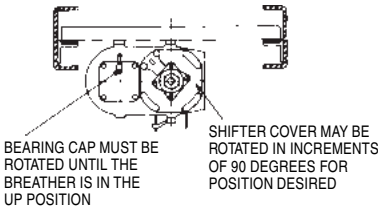

### Horizontal Mounting

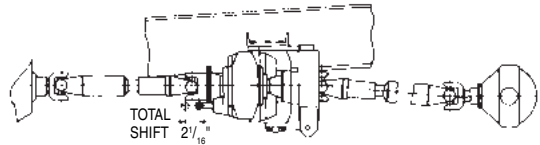
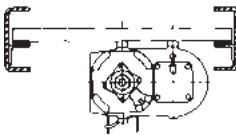

### Model 901 Split Shaft Dimensional Drawings

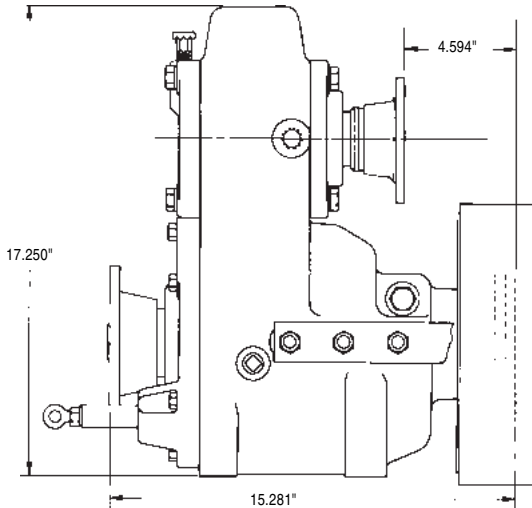
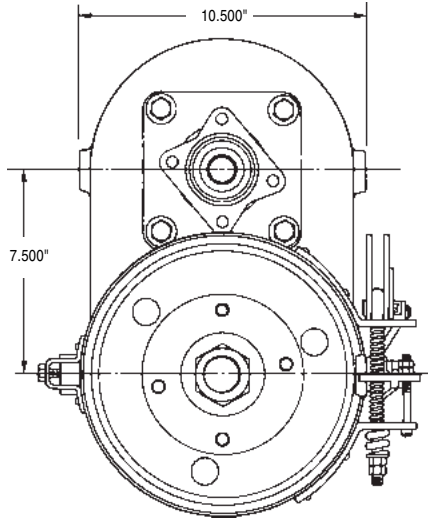

### Model 912 Split Shaft Installation Drawing

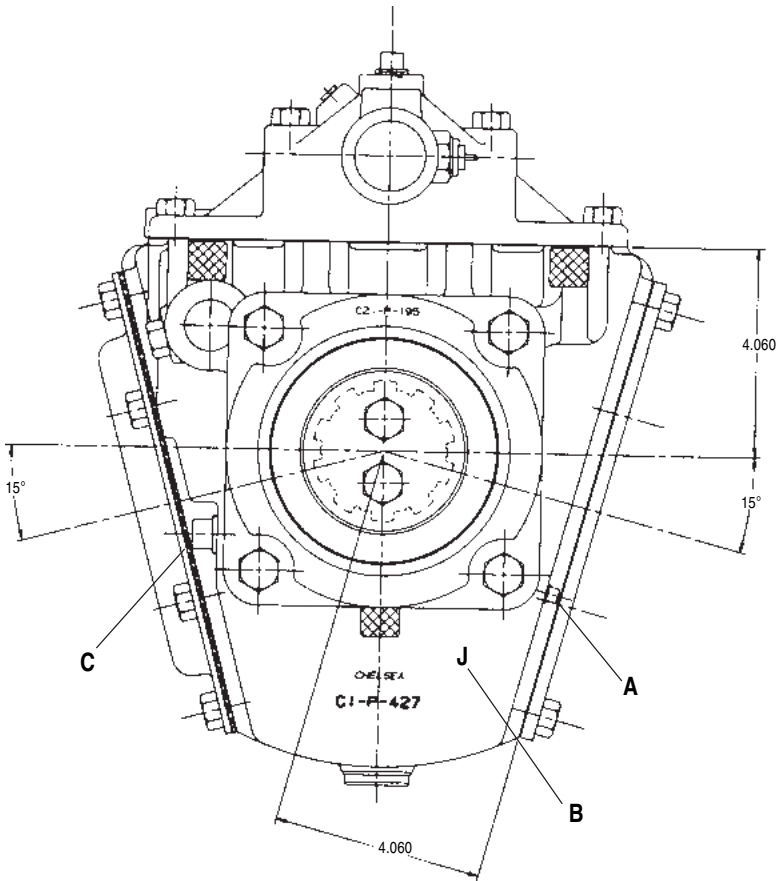

When filling the 912 series split shaft unit with oil it is always important not to over fill the Power Take-Off unit. This is very important when installing two 885 series P.T.O.s.

A change was made to the 912 housing (1-P-484) lowering the fill plug located on the lower right rear of the housing (see drawing, Note A). To verify that you have a 912 housing that has the proper plug location for checking the oil level with two 885 Power Take-Offs, check for the "Revision" level of the housing. This revision level is in the form of a letter located on the driveline output side of the housing and located to the right of the casting number (see drawing, Note B). If the Revision letter is "J" or higher then the plug in the housing has been changed for the correct oil level for two 885 series Power Take-Off.

On all other applications or with one 885 series P.T.O. use the oil level plug located on the left side of the housing to check for proper oil levels (see drawing, Note C).

### Model 912 Split Shaft Dimensional Drawing

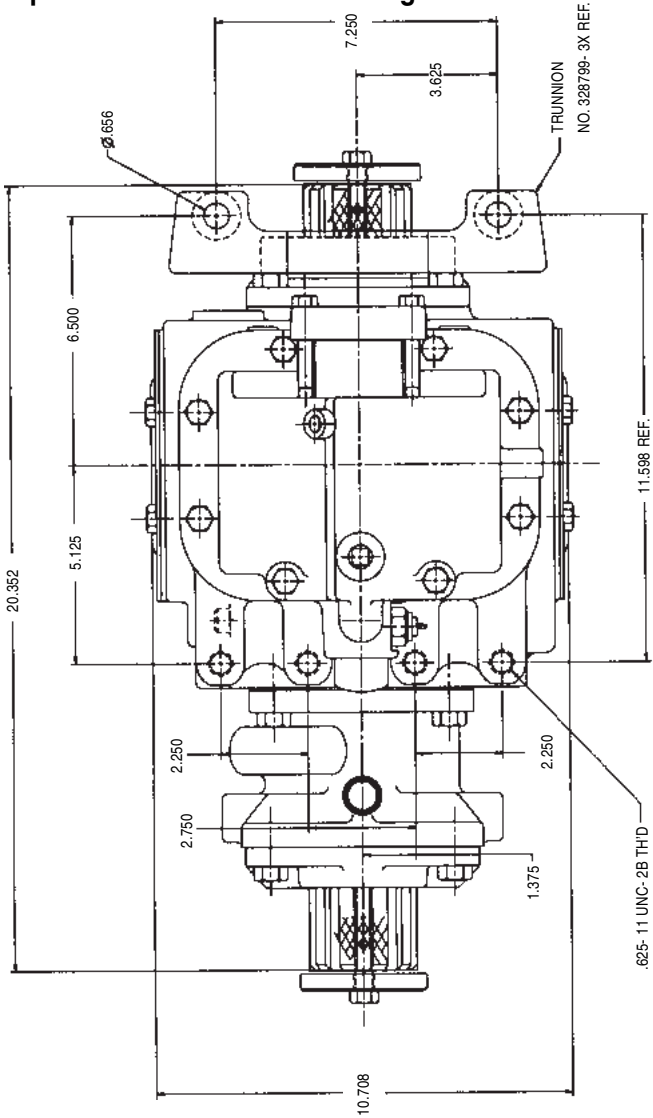

### Model 931 Split Shaft Installation Drawings

With Cover and Crossmember Support - Below

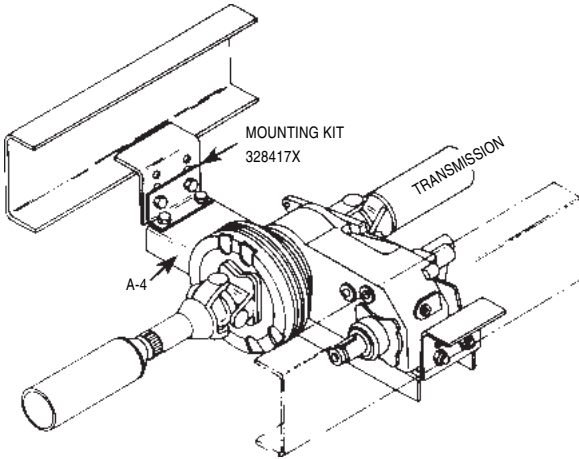

With Cover and Crossmember Support - Above

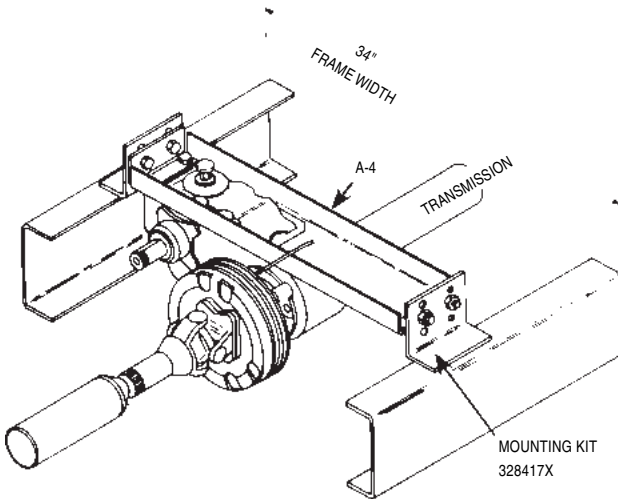

**NOTE:** When installing the Split Shaft, the **Vent Assembly** must be in an upright position.

### Model 931 Split Shaft Dimensional Drawings

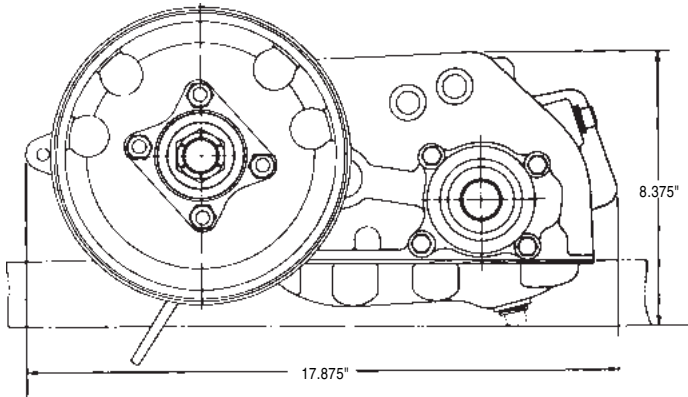
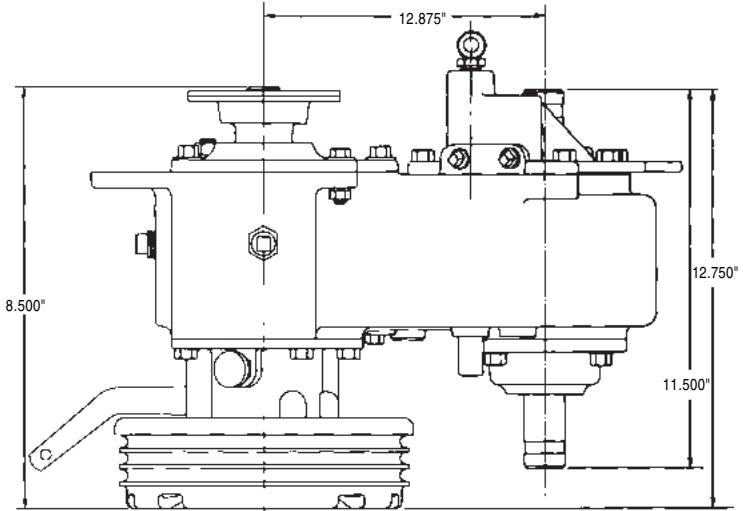

### Model 941 Split Shaft Installation Drawings

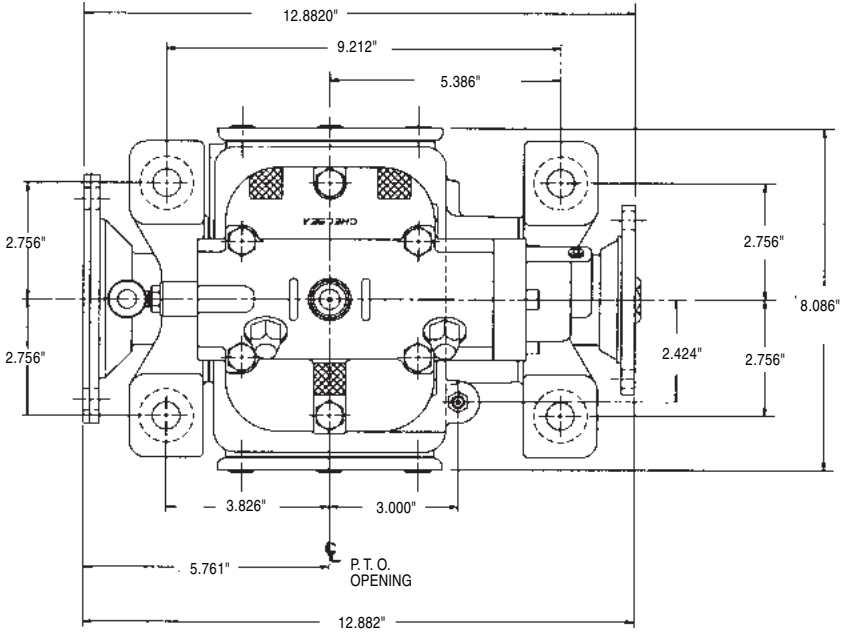

### Model 941 Split Shaft Dimensional Drawings

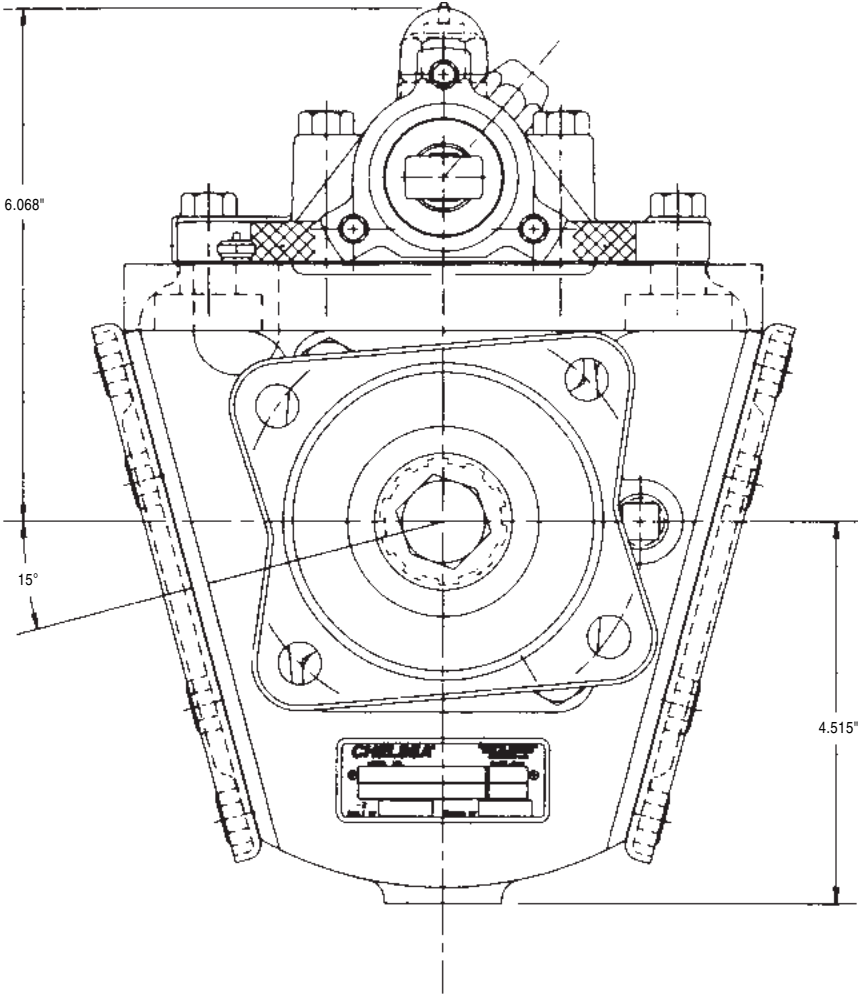



## Installation Instructions – Gear Boxes Models 700, 712, 721, 732, 741, 2230, and 2442

Gear boxes are installed very similarly to split shaft Power Take-Offs. The differences are that the gear box is driven from a Power Take-Off rather than the transmission main shaft, and the gear box drives a piece of equipment rather than the rear axle. Installation of a gear box requires fabrication of new shafts rather than cutting into the existing driveline. Listed are the necessities for a good gear box installation which are basically the same as those required for a good split shaft Power Take-Off installation. The unit itself is mounted on a plate which must be mounted to a sturdy support on the vehicle. Rubber isolation of the unit is important to prevent transmitting vibrations throughout the vehicle. Then follow the steps below:

1. **Front**—The short coupled joint connecting the Power Take-Off to the gear box should be installed so as to permit equal joint angles of less than 3°.

**Rear**—The two joint assembly connecting the gear box to the driven equipment should be installed so as to permit equal joint angles of less than 5°. To insure the best performance, the joint angles should be kept within a minimum of 1° to 3°.

**Front & Rear**—The two joint assemblies at the front and rear should be installed so as to permit equal joint angles of less than 5°.

2. Determine a suitable location for mounting the gear box. Raise or lower or move the gear box front or rear as required to reduce the joint angles to a minimum, but not less than 1°.
3. Align the gear box with the Power Take-Off and driven equipment.
  - A. For the best installation and optimum performance, the input and output shafts of the gear box should be parallel respectively with 1° to the output shaft of the Power Take-Off and the input shaft of the driven equipment.
  - B. With the shafts parallel, the joint angles should be in one plane only. Make sure the offset in the horizontal or vertical planes will provide for equal joint angles of less than 3° with a short coupled joint or less than 5° with a two joint assembly.
4. Excessive angles result in a loss of speed and power. The figures shown below are approximate and any angles less than those shown will provide a better installation.

Speed	True Joint Operating Angle
5,000 R.P.M.	3° 15'
4,000 R.P.M.	4° 15'
3,000 R.P.M.	5° 50'

Slight angles of 1° in each joint are necessary to permit circulation of the needles.

5. If at all possible, the shafts front and rear should be assembled, straightened, and balanced. The various models of gear boxes offer three (or several) types of shifters. Wire shift is installed identically to a six bolt Power Take-Off installation. Linkage for lever controls must be designed and fabricated by the installer. Air shift plumbing is shown in the typical sketch on pages 33-35 for a single acting air shift.

## Breather Hose Installation

When installing a breather hose assembly on a gear box or split shaft, the top of the vent assembly must be at least 12 inches above the unit as shown in figure 1. Figure 2 shows an incorrect installation. When installing any vent assembly, make sure it is in the upright position.

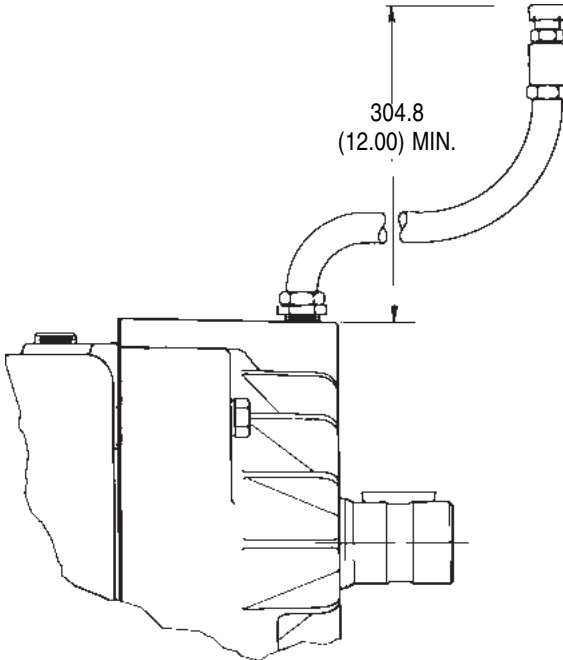

Fig. 1

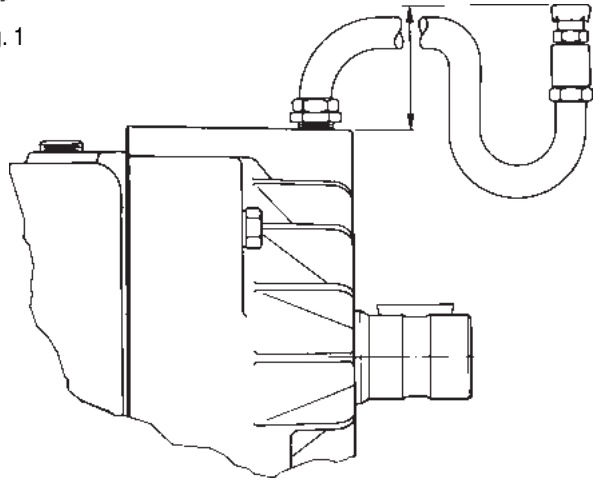
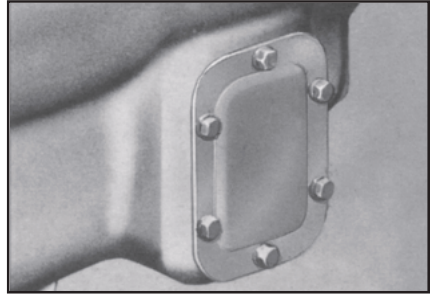

Fig. 2

## Application Questions for Installation of a P.T.O. to a Split Shaft

Specifying and mounting a P.T.O. to the 912 & 914 Split Shaft is accomplished the same as on a transmission. There are certain application questions and installation procedures that you should follow. The next four pages will take you through these steps.

1. What is the make and model of your transmission?
2. Which P.T.O. opening will be used?
3. What accessory is to be driven?
4. How much horsepower is required to drive the accessory?
5. What is the required rotation of the P.T.O. ?
6. What is the required P.T.O. output shaft speed as a percent of engine speed?
7. What is the required method of shifting the P.T.O. – cable, lever or air?

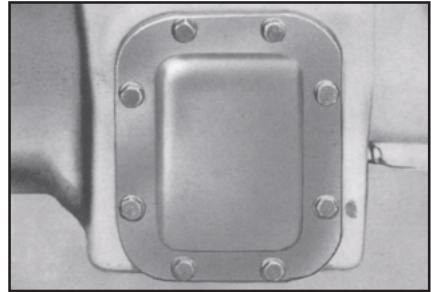

S.A.E. 6 Bolt

S.A.E. 8 Bolt  
Standard SAE Power Take-Off Apertures

Once all the answers to these questions have been determined, a transmission mounted P.T.O. can be selected to meet the horsepower, speed, and rotation that you require.

Having made the selection of a P.T.O., you are ready to start the installation.

### P.T.O. Drive Gear Location

The standard location for the P.T.O. drive gear in the transmission is 1/2" to the front or 1/2" to the rear of the vertical center line.

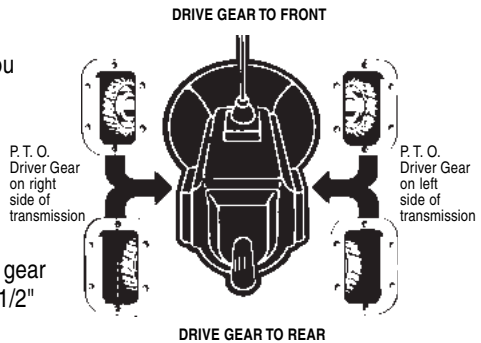

## Mounting P.T.O. to Split Shaft for 6 or 8 Bolt Applications

1. Drain the oil from the transmission, and remove the P.T.O. aperture cover plate. (See Fig. 1.)



Fig. 1

2. Discard the cover plate and cover plate gasket. Clean the aperture pad using a putty knife or wire brush. (See Fig. 2.)

**NOTE:** Stuff a rag in the aperture opening to prevent dirt from entering the transmission while you are cleaning it.



Fig. 2

3. Using your hand, rock the P.T.O. drive gear in the transmission (See Fig. 3.) and the driven gear in the P.T.O. assembly (See Fig. 4.). Rocking the gears provides two important factors.

A. It shows you the amount of backlash that has been designed into each unit.

B. It is helpful in establishing the proper backlash when installing the P.T.O.

4. Install the proper studs in the P.T.O. aperture pad using a stud driver. (See Fig. 5.)
5. Where holes are tapped through the transmission case, use Permatex or an equivalent to prevent leaks.



Fig. 3



Fig. 4

**NOTE:** Avoid contact of Permatex with automatic transmission fluid in automatics. Always check to be sure the studs do not interfere with transmission.

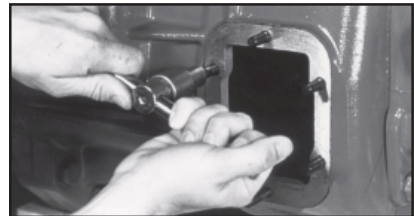

Fig. 5

## Mounting P.T.O. to Split Shaft (Continued)

6. Tighten the studs securely, and torque them to 10 - 15 ft. lbs. (1.38 - 2.07 kg. meters) for the 6 bolt and 15 - 20 ft. lbs. (2.07 - 2.77 kg. meters) for the 8 bolt. (See Fig. 6.)

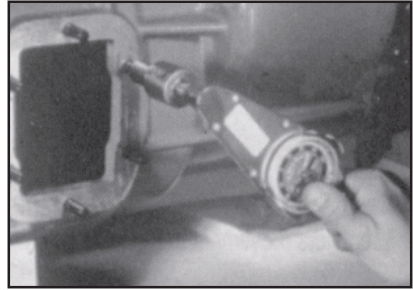

Fig. 6

7. Place the correct number of gaskets over the studs. (See Fig. 7.) Do not use Permatex between gaskets because you may want to add or subtract gaskets to obtain the proper backlash.

- When mounting a P.T.O., use gaskets between all mounting surfaces.
- Do not stack more than 3 gaskets together.
- Usually one thick gasket .020" (.50 mm) will be required.
- Remember the lubricant in the transmission also lubricates the P.T.O. Therefore, at least one gasket must always be used on either side of filler blocks, adapter assemblies, or adapter plates. More gaskets may be required when establishing proper backlash.



Fig. 7

8. Secure P.T.O. to the transmission. The 220 Series must always have a copper washer under its one capscrew head which goes through the inside of the housing. (See Fig. 8.)

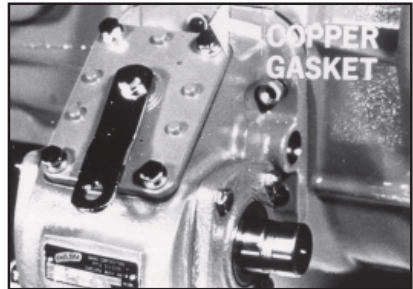

Fig. 8

9. Fasten the P.T.O. to the transmission. Torque the 6 bolt to 30 - 35 ft. lbs. (4.14 - 4.84 kg. meters) and the 8 bolt to 45 - 50 ft. lbs. (6.22 - 6.91 kg. meters). (See Fig. 9.)

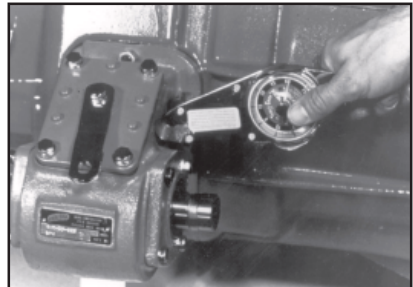
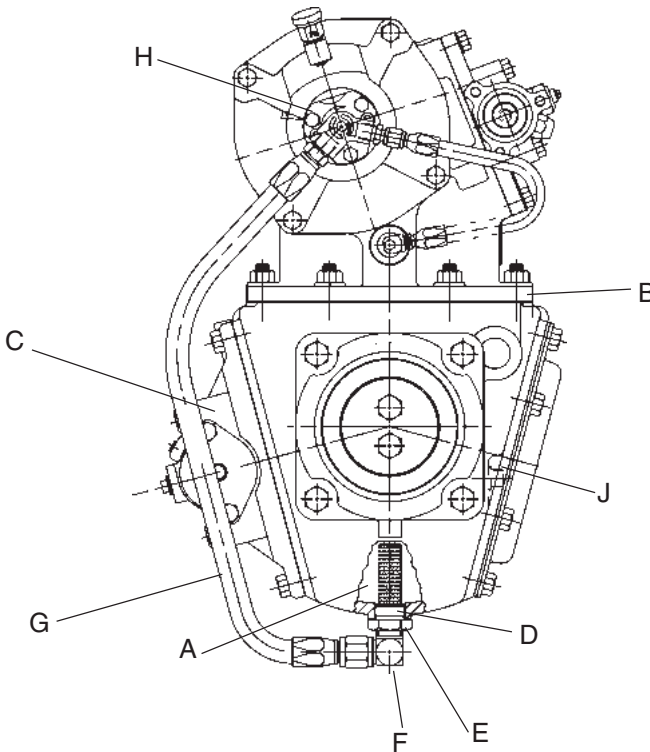

Fig. 9

## Installation Instructions for 880 Series with “L” Output, Top Mounted to 912 Series Split Shaft - Requiring Self-Lube Option

1. Drain split shaft oil at drain plug (A). Filter or screen oil & reuse if desired.
2. Remove top split shaft aperture cover plate at (B) or air shift Assembly (C) & reassemble to either side of split shaft in place of shipping cover. Install P.T.O. on split shaft & set backlash at .006" to .012". (See page 28 for checking proper backlash)
3. Install copper gasket (D), screened strain plug (E) & 90° elbow (F) in place of drain plug at (A). Also install pressure lube hose (G) between elbow (F) and pump (H). (Use pipe sealant on all pipe threads)
4. Fill split shaft with filtered, screened or new oil at fill plug (J), until oil reaches plug level, then reinstall plug.
5. Finish P.T.O. & split shaft installation per owner's manual. Also install shaft and/or pump to be driven by P.T.O.
6. After brief P.T.O. operation, remove fill plug (J), add oil until it reaches plug level, then reinstall plug.

**IMPORTANT:** Lube pump (H) must rotate clockwise (engine rotation) as view from front of vehicle.



## Checking Backlash

To check for proper backlash on P.T.O. with shift cover:

1. Remove the P.T.O. shift housing and/or inspection plate.
2. Mount the dial indicator so that it registers movement in the input gear (driven gear) of the P.T.O. (See Fig. 10.)



Fig. 10

**NOTE:** See Figure 11 for the proper location of the dial indicator's contact point. (Two common types of dial indicators are shown.)

3. Hold the P.T.O. driver gear in the transmission with a screwdriver or bar, and rock the P.T.O. input gear (driven gear) back and forth with your hand. Note the total movement on the dial indicator.
4. Establish backlash at .006" - .012" (.15 mm - .30 mm) by adding or subtracting gaskets.

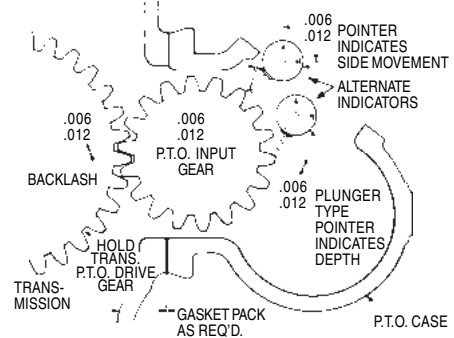

Fig. 11

**NOTE:** For any additional information on hooking up the shifter or installation of the P.T.O., please consult the Owner's Manual included with the unit.

**General rule—A Chelsea .010" gasket will change backlash approximately .006." A .020" gasket changes backlash approximately .012."**

### Cable Control Installation Instructions\*

1. Find a suitable area on the dash to install the cable control (328346-10X) and the control plate (68-P-18) indicator light.

Optional Location: As an option the control cable and knob can be located through floor. Using this option the control plate and indicator light should still be located on dash, in close proximity.

**NOTE:** The location of the cable control and the control plate should be as close to each other as possible and easily accessible by the driver or operator, but should not be an obstacle to driver movement nor interfere with other controls, instruments, or equipment.

2. CAUTION: Before drilling any holes, make sure there is adequate room on both sides through dash wall, drill a 1/2" (.5") diameter hole for the control cable. [1]
3. Install the control cable on the dash using the hex nuts supplied with the cable. The knob can then be screwed into place [2]. The length of cable can then run through the firewall and back to the P.T.O. —making sure it is kept away from the exhaust, moving parts, etc.

**NOTE:** Do not kink the cable. In order for the cable to operate properly, there can be no bends smaller than 6 inch radius. Total bends in the cable should not exceed 360° (example - four 90° bends in cable).

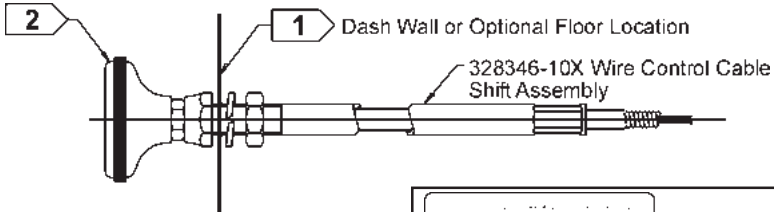

4. Using the template found on page 38 (SK-168) drill the necessary holes for the control plate-indicator light.
5. Install the control plate (68-P-18) stick on decal and indicator light on the dash using the hardware supplied in the 328751-1X installation kit (Fig. 25).

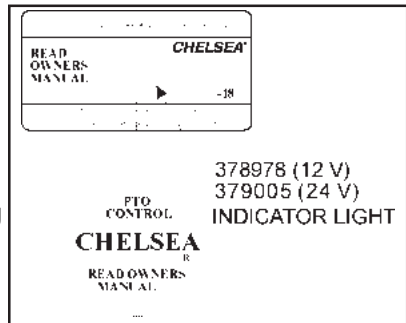

Fig. 25

\* All six bolt wire shifts with the exception of the reversible, dual shift units, and some gear boxes.



**Cable Control Installation Instructions (Continued)**

6. Determine from which direction the cable must come in order for the unit to be disengaged when the knob is all the way in.

**NOTE:** The shifter must always be installed in the following manner:

\* CABLE IN: P.T.O. DISENGAGED(6A): OUT OF GEAR POSITION

CABLE OUT: P.T.O. ENGAGED(6B): IN GEAR POSITION

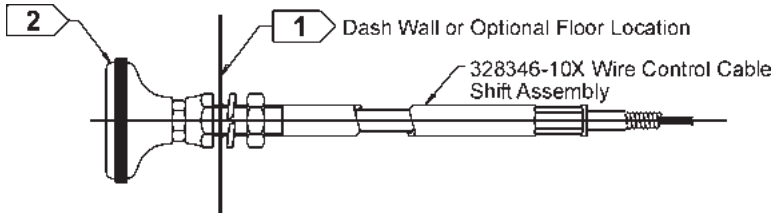

\* The wire shift cable should be installed so that when the cable (knob) is pushed all the way in, the P.T.O. has also moved the full travel of the P.T.O. shifter, to the disengaged mode.

7. Install the wire control bracket found in either the 328380X or 328380-1X wire control parts bag. [7]
8. Line the cable up with the wire control bracket and shifter lever (disengaged position) on the P.T.O. cover assembly [8]

**NOTE:** It may be necessary to change the position of the shifter lever on the P.T.O. To do this, remove the shifter cover from the unit. This will prevent the possible loss of the poppet and/or spring into the transmission if the shifter post assembly should be pushed through the cover when reinstalling the lever.

9. Shift the P.T.O. to the engaged position to see how much of the cable casing must be cut to allow the lever enough travel to shift in and out completely. The casing need only go just beyond the bracket, whereas, the wire must be long enough to go through the swivel pin in the shifter lever. [9]

**NOTE:** In some instances the cable control may not be long enough. Chelsea has available four longer lengths than the standard ten-foot cable. These come in five foot increments (i.e., 328346-15X = 15-foot cable).

10. When the length of the casing has been determined, pull the wire back through until the case can be cut without cutting the wire. Use a hacksaw or heavy pair of side cutters to cut the casing.

**NOTE:** The cable can be held by a bench vise as long as the jaws are not tightened to the point where the case mushrooms. If a vise is not accessible, a pair of vise grips will do the job.

### Cable Control Installation Instructions\* (Continued)

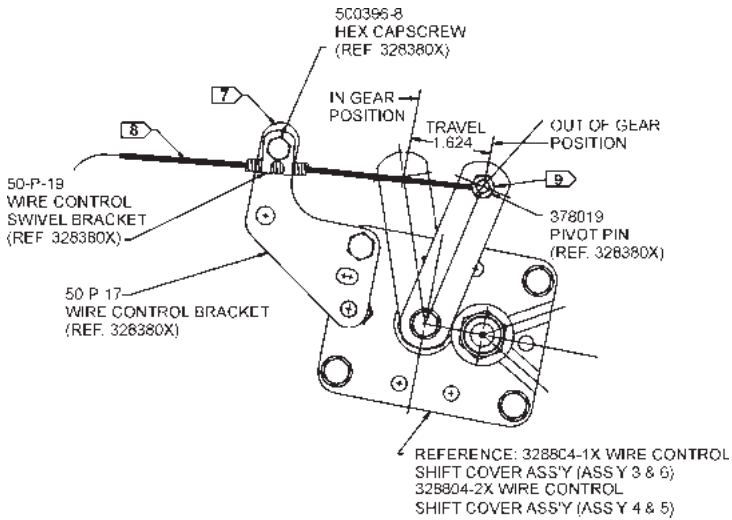

11. Push the wire back through and install the cable using the hardware from the previously mentioned wire control parts bag (328380X).
12. Cut the excess wire after the cable casing and wire have been installed and tightened.

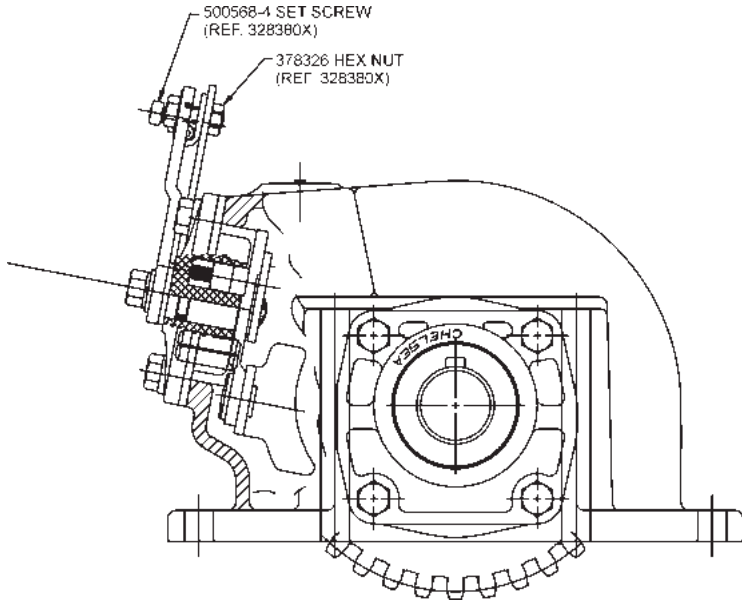

\* All six bolt wire shifts with the exception of the reversible, dual shift units, and some gear boxes.

Cable Control Installation Instructions\* (Continued)

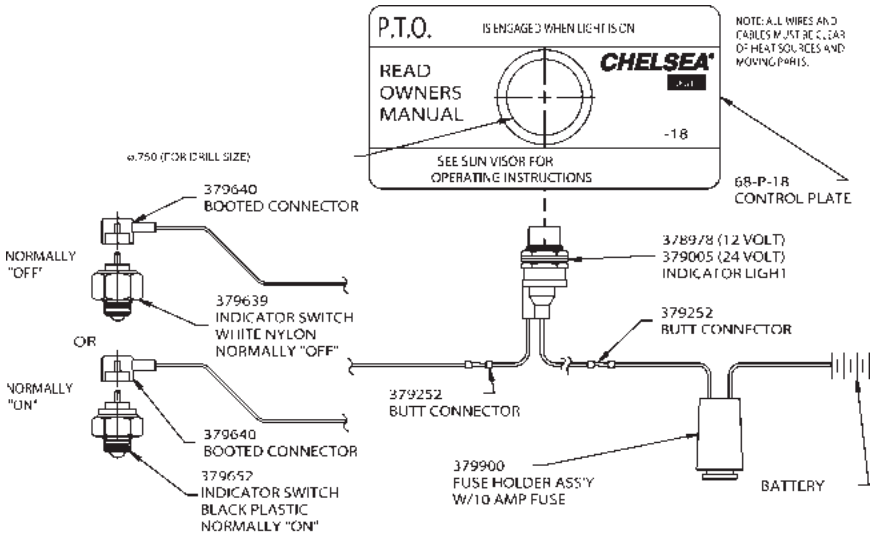

Indicator Light Installation Sketch (SK-286 Rev G)

**CAUTION:** Indicator switches are capable of 0.5 amps maximum.

**NOTE:** All wires and cables must be clear of heat source and moving parts.

13. Shift the P.T.O. to insure enough casing has been removed to allow full gear engagement.
14. Install the wiring for the indicator light using the schematic above (SK-286 Rev G).

**NOTE:** Check both the cable and indicator light wires to be certain that they are not near the exhaust system or any moving parts. Carefully fasten to stationary parts of the vehicle if necessary.

15. Shift the P.T.O. The following should be adhered to:
  - 15A. CABLE IN: P.T.O. DISENGAGED: LIGHT OUT
  - 15B. CABLE OUT: P.T.O. ENGAGED: LIGHT ON

**NOTE:** The P.T.O. should be checked for continuity as per the instructions in this manual.

**NOTE:** Cable must be rigidly mounted-possibly to the transmission within 12-24" of the P. T. O.

\* All six bolt wire shifts with the exception of the reversible, dual shift units, and some gear boxes.

**Air Shift Installation Sketch for the 2442 Series Gear Box (SK-231 Rev D)**

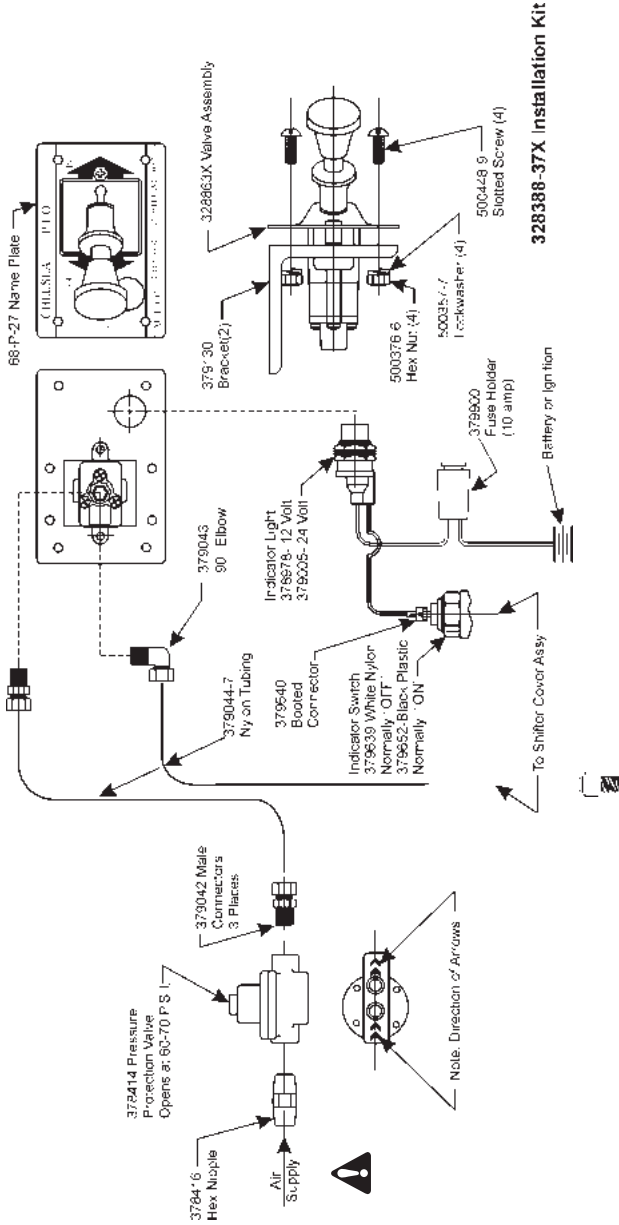

**328388-37X Installation Kit**

- Warning:** Connect directly to the air supply. Do not use tubing between the air supply and the pressure protection valve.
- Caution:** When installing nylon tubing avoid sharp angles, exhaust and manifold systems.
- Important:** When this installation is used on vehicles with automatic transmissions, the P.T.O. drive gear must be stopped before shifting.
- NOTE:** Tube nut is reusable as long as nylon tubing is not removed from the tube nut.
- The template for the control plate is on page 36.

## Air Shift Installation Sketch for 901, 912, and 941 Split Shafts (SK-276 Rev G)

### 328388-61X Installation Kit

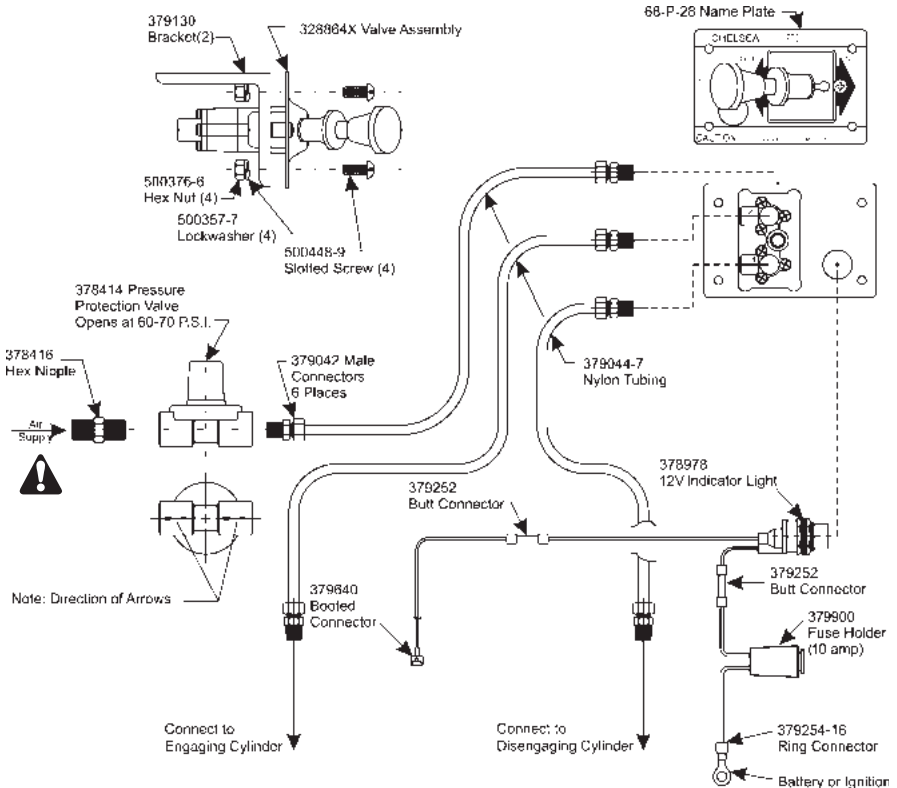

**Warning:** Connect directly to the air supply. Do not use tubing between the air supply and the pressure protection valve.

**Caution:** When installing nylon tubing avoid sharp angles, exhaust and manifold systems.

**Important:** When this installation is used on vehicles with automatic transmissions, the P.T.O. drive gear must be stopped before shifting.

**NOTE:** Tube nut is reusable as long as nylon tubing is not removed from the tube nut.

**NOTE:** The template for the control plate is [on page 37](#).

Air Shift Circuit 2230 Series (SK-246 Rev E)

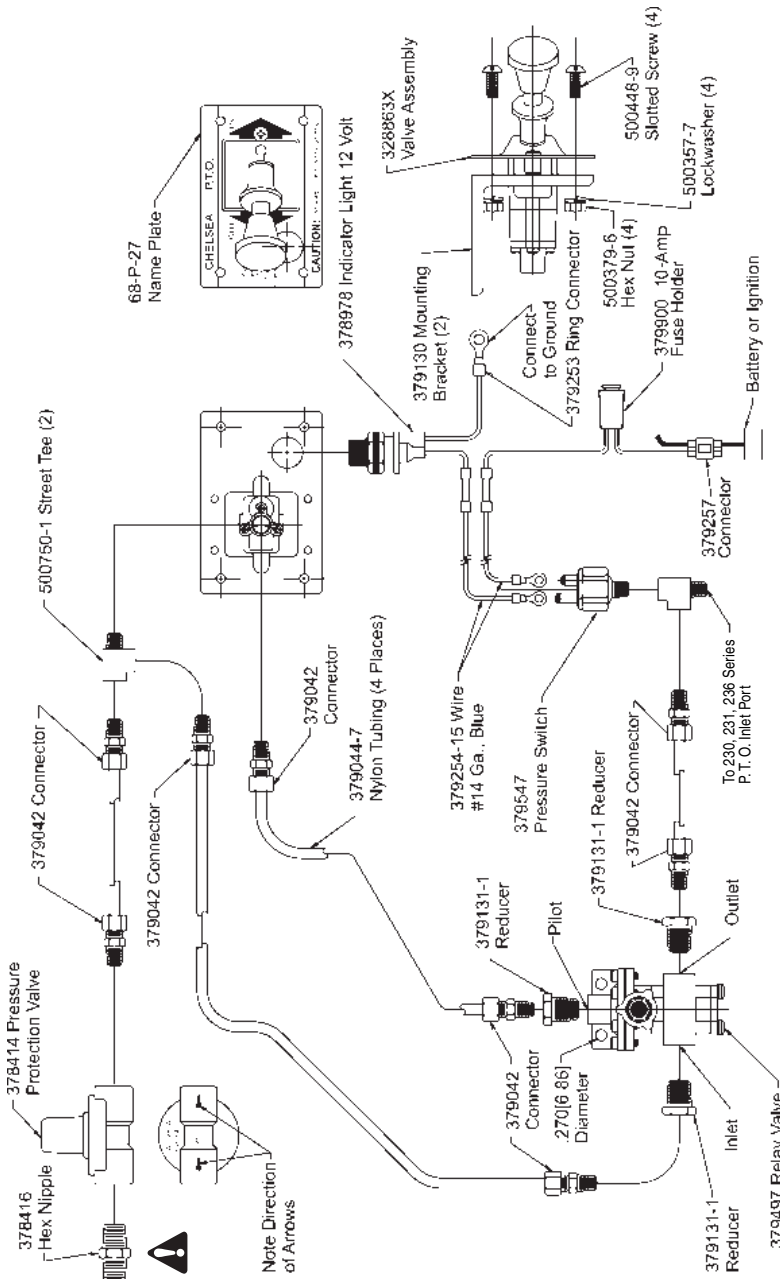

**Warning:** Connect directly to air supply. Do not use tubing between air supply and pressure protection valve.

### Dash Drilling Template for 2442 Series Gear Box Air Shift Control (SK-204 Rev C)

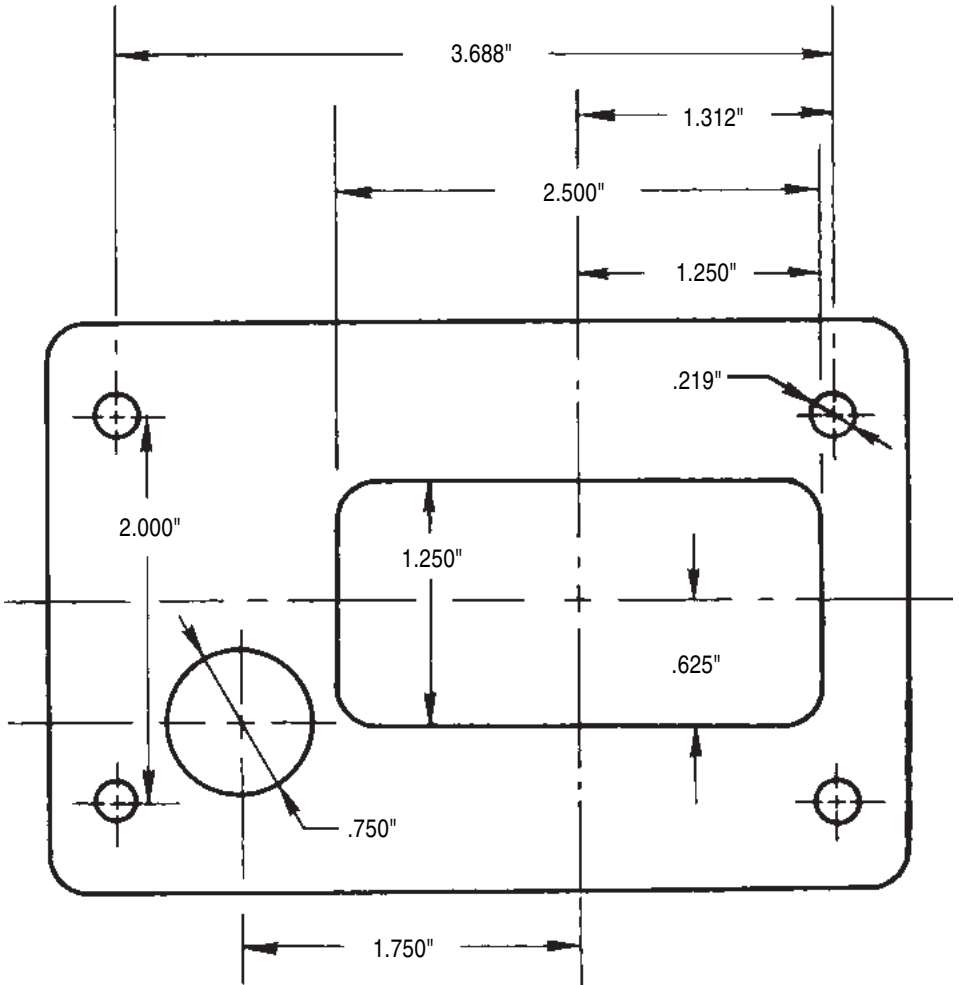

Dash Drilling Template for 901, 912, and 941 Split Shafts Air  
Shift Controls (SK-204 Rev C)

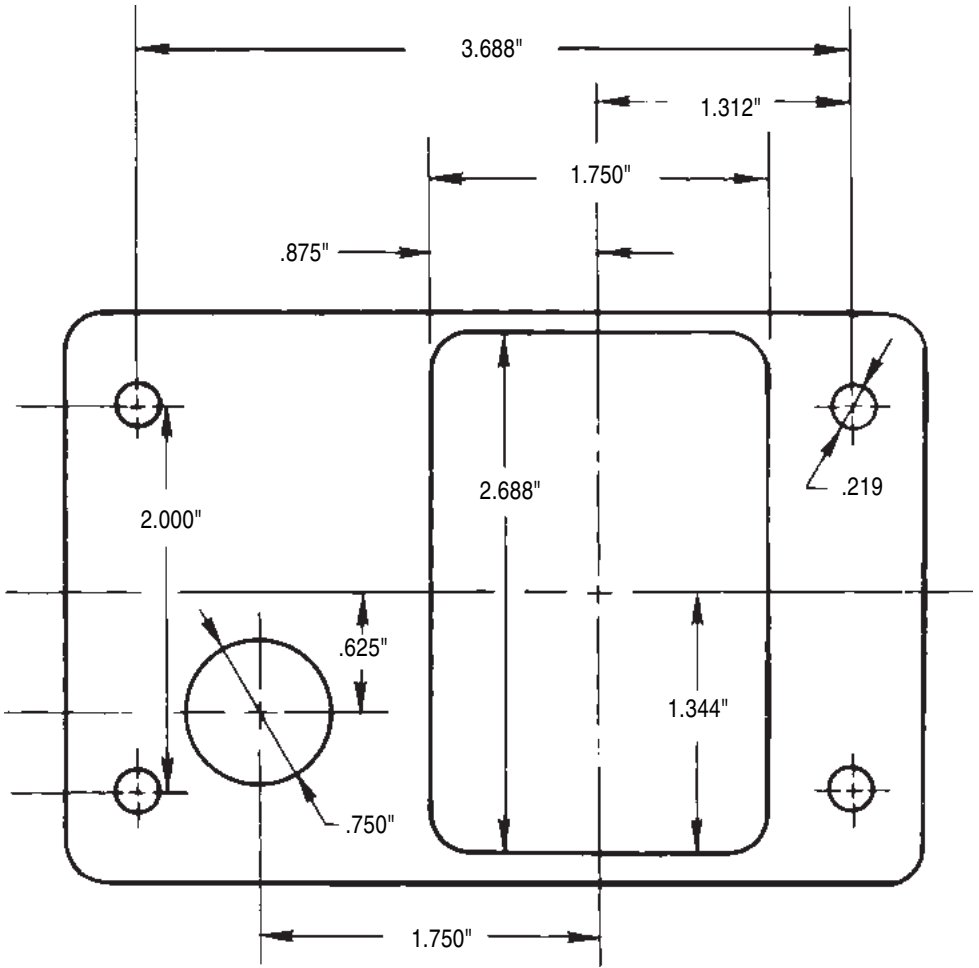



### Dash Drilling Template for Wire and Lever Controls (SK-168)

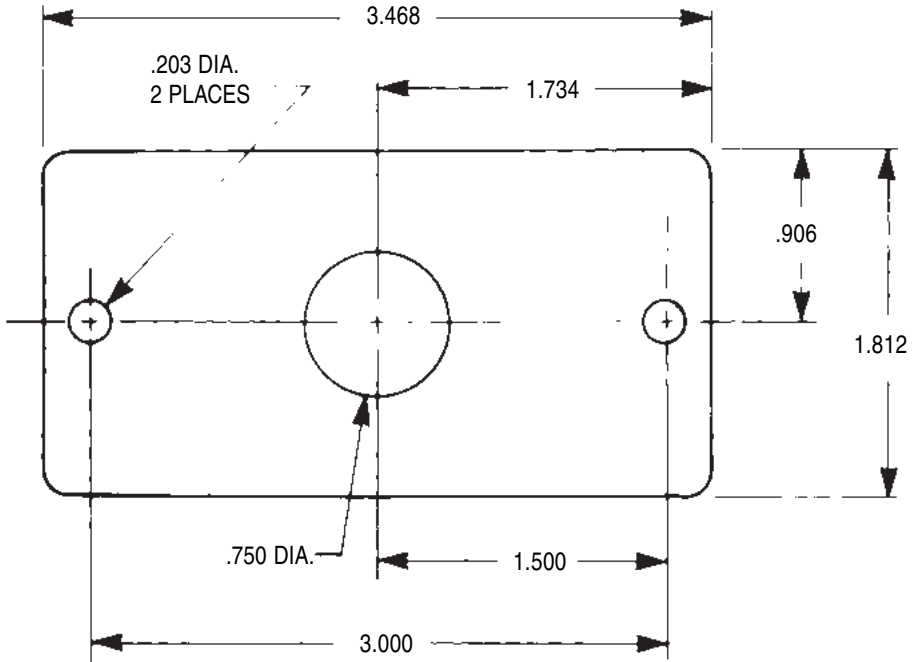

### Indicator Light Installation (SK-286 Rev G)

For wire and lever shift option on the 700, 712, 721, 732, 741, 901, 912, 931, 941 and 2442 gear boxes.

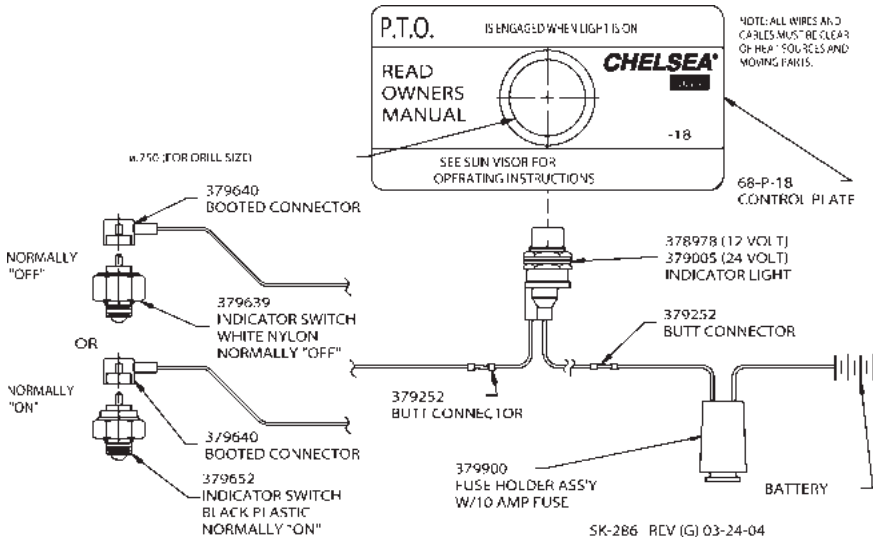

**Caution:** Indicator switches are capable of 0.5 amps maximum.

**NOTE:** All wires and cables must be clear of heat source and moving parts.

## Continuity Check

### 379639 and 379652 Indicator Switches

In order to insure that the switch is functioning properly, the following procedure can be used with the unit on a bench, or installed.

1. Use a continuity checker, battery type, either meter or light. Attach one (1) probe to the screw on the 379639 or 379652 Indicator Switch.

**Note:** Make sure 379639 and 379652 Indicator Switches in the P.T.O. shifter or housing are torqued to 10-15 ft. lbs. (1.38-2.07 kg meters).

2. With the other probe, make contact with the shifter cover or housing (Fig. 23).
3. Actuate shifting device and the meter or light\* should be actuated when P.T.O. gear is engaged (Fig. 24).
4. Shift unit out of gear and the meter or light\* should return to normal as shown.



Fig. 23

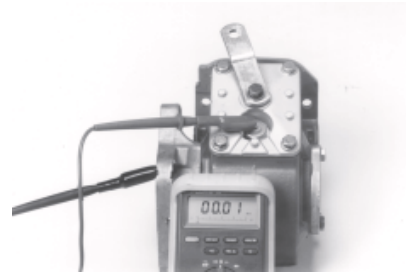

Fig. 24

This test procedure can be used to check Chelsea wire, lever, and air shifter covers, although an air source would be necessary for the latter.

\* If a meter is not available the light in the 328751-1X can be used. A six volt battery is all that is necessary for a power source.

**CAUTION:** Indicator switches are capable of 0.5 amps maximum.

## Troubleshooting

**Driver Training:** One of the major causes of bearing and gear failures in the auxiliary unit is poor driving habits. Drivers should be taught to always use the Lo Speed or reductions available in the auxiliary unit and keep the front box in the higher ratios not vice versa.

Worn and pitted gears, as well as worn and pitted bearings are usually caused by excessive use of the auxiliary overdrive gears with the mainbox in lower gear ratios.

Broken teeth in the auxiliary unit are usually caused by drivers trying to start their vehicles with the auxiliary unit in the high ratio while the big reduction is made in the front box. Frogging or quick release of clutch gives a jump start which is also noted for breaking teeth.

**Noisy Operation:** Noise is usually very elusive and generally not the fault of the auxiliary; therefore, mechanics should road test to determine if the driver's complaint of noise is actually in the auxiliary. Remember that auxiliary units act as sounding boxes and in numerous instances, drivers have insisted that the noise was in the auxiliary. However, investigations revealed the noise to be caused by one of the following conditions:

- A. Fan out of balance or bent blades.
- B. Defective vibration dampers.
- C. Crankshafts out of balance.
- D. Flywheels out of balance.
- E. Flywheels mounting bolts loose.
- F. Engine rough at idle producing rattle in gear train.
- G. Clutch assembly out of balance.
- H. Engine mounts loose or broken.
- I. P.T.O. gear not fully engaged or housing not properly shimmed.
- J. Universal joints wornout.
- K. Propeller shafts out of balance.
- L. Universal joint angles out of plane or at an excessive angle.
- M. Center bearings in driveline dry, not mounted properly, etc.
- N. Wheels out of balance.
- O. Tire treads humming or vibrating at certain speeds.
- P. Air leaks on suction side of induction system—especially with turbo-chargers.

Mechanics should try to locate and eliminate noise by means other than auxiliary removal, or overhaul. However, if the noise appears to be in the auxiliary, try to break it down into the following classifications. If possible, determine what position the gear shift lever is in when the noise occurs. If the noise is evident in only one gear position, the cause of the noise is generally traceable to the gears in operation.

- A. Growling and humming or, more serious, a grinding noise. These noises are caused by worn, chipped, rough, or cracked gears. As gears continue to wear, the grinding noise will be noticeable, particularly in the gear position that throws the greatest load on the worn gear.

## **Troubleshooting**

- B.** Hissing or, more serious, a thumping or bumping type noise. Hissing noises can be caused by bad bearings. As bearings wear and retainers start to break up, etc., the noise could change to a thumping or bumping.
- C.** Metallic rattles within the auxiliary usually result from a variety of conditions. Engine torsional vibrations are transmitted to the transmission through the clutch, which may be amplified and transmitted to the auxiliary through the connecting propeller shaft. In heavy duty equipment, clutch discs with vibration dampers are not used, so a rattle, particularly in neutral, is common with diesel equipment. In general, engine speeds should be 600 R.P.M. or above to eliminate objectionable rattles and vibration during the idle. Always leave the main box in neutral and the auxiliary unit in gear when idling. A defective or faulty injector would cause a rough or lower idle speed and a rattle in the auxiliary. Rattle could also be caused by excessive backlash in P.T.O. unit mounting.
- D.** Improper lubricants or lack of lubricant can produce noises. Auxiliaries with low oil levels sometimes run hotter than normal, as there is insufficient lubricant to cool and cover the gears.
- E.** Squealing, particularly when the auxiliary is operating at higher speeds, could be caused by one of the free running gears seizing on the thrust face or fluted diameter temporarily and then letting go. In general, a mild seizure will clear itself up and the auxiliary will continue to operate satisfactorily without this defect being known. See "G."
- F.** Gear seizure at High Speed, usually accompanied with a loud squealing noise, is readily apparent to the driver, since the truck will suddenly slow down as if the brakes were being applied. If the truck continues to move ahead, even though the gear shift lever is placed in neutral, it would indicate the floating gear on the main shaft had seized. Depressing the clutch should interrupt the driving torque. The seized gear could be checked quite readily by depressing the clutch and checking the action with the gear shift lever progressively in all shift positions. If releasing the clutch tends to kill the engine, then this gear position has not seized. In other words, the auxiliary would be in two gears at the same time. By a process of elimination, the gear at fault can be readily identified. See "G."
- G.** Vibration. Gear seizures on thrust faces or fluted diameters are usually caused by vibrations in the power train. This could be engine, propeller shafts, joint angles, rear axles, differentials, etc.

## Power Take-Off Maintenance

Due to the normal and sometime severe torsional vibrations that Power Take-Off units experience, operators should follow a set maintenance schedule for inspections. Failure to service loose bolts or Power Take Off leaks could result in potential auxiliary Power Take-Off or transmission damage.

Periodic P.T.O. MAINTENANCE is required by the owner/operator to ensure proper, safe and trouble free operation.

**Daily:** Check all air, hydraulic and working mechanisms before operating P.T.O. Perform maintenance as required.

**Monthly:** Inspect for possible leaks and tighten all air, hydraulic and mounting hardware, if necessary. Torque all bolts, nuts, etc. to Chelsea specifications. Insure that splines are properly lubricated, if applicable. Perform maintenance as required.

With regards to the direct mounted pump splines, the P.T.O. requires the application of a specially formulated anti-fretting, high pressure, high temperature grease. The addition of the grease has been proven to reduce the effects of the torsional vibrations, which result in fretting corrosion on the P.T.O. internal splines as well as the pump external splines. Fretting corrosion appears as a "rusting and wearing" of the pump shaft splines. Severe duty applications, which require long P.T.O. running times and high torque may require more frequent regreasing. Applications such as Utility Trucks that run continuously and are lightly loaded also require frequent regreasing due to the sheer hours of running time. It is important to note that service intervals will vary for each and every application and is the responsibility of the end user of the product. Chelsea also recommends that you consult your pump owners manuals and technical services for their maintenance guidelines. Fretting corrosion is caused by many factors and without proper maintenance; the anti-fretting grease can only reduce its effects on components.

Chelsea offers the grease to our customers in two packages. The first is a 5/8 fluid ounce tube (379688), which is included with every applicable P.T.O., and the second is a 14-ounce grease cartridge (379831). Chelsea also offers greaseable shafts for most all output designators.

**Warranty:** Failure to comply entirely with the provisions set forth in the appropriate Owner's Manual will result in voiding of ALL Warranty consideration.

## Offer of Sale

The items described in this document and other documents or descriptions provided by Parker Hannifin Corporation, its subsidiaries and its authorized distributors are hereby offered for sale at prices to be established by Parker Hannifin Corporation, its subsidiaries and its authorized distributors. This offer and its acceptance by any customer ("Buyer") shall be governed by all of the following Terms and Conditions. Buyer's order for any such items, when communicated to Parker Hannifin Corporation, its subsidiary or an authorized distributor ("Seller") verbally or in writing, shall constitute acceptance of this offer.

**1. Terms and Conditions of Sale:** All descriptions, quotations, proposals, offers, acknowledgments, acceptances and sales of Seller's products are subject to and shall be governed exclusively by the terms and conditions stated herein. Buyer's acceptance of any offer to sell is limited to these terms and conditions. Any terms or conditions in addition to, or inconsistent with those stated herein, proposed by Buyer in any acceptance of an offer by Seller, are hereby objected to. No such additional, different or inconsistent terms and conditions shall become part of the contract between Buyer and Seller unless expressly accepted in writing by Seller. Seller's acceptance of any offer to purchase by Buyer is expressly conditional upon Buyer's assent to all the terms and conditions stated herein, including any terms in addition to, or inconsistent with those contained in Buyer's offer. Acceptance of Seller's products shall in all events constitute such assent.

**2. Payment:** Payment shall be made by Buyer net 30 days from the date of delivery of the items purchased hereunder. Amounts not timely paid shall bear interest at the maximum rate permitted by law for each month or portion thereof that the Buyer is late in making payment. Any claims by Buyer for omissions or shortages in a shipment shall be waived unless Seller receives notice thereof within 30 days after Buyer's receipt of the shipment.

**3. Delivery:** Unless otherwise provided on the face hereof, delivery shall be made F.O.B. Seller's plant. Regardless of the method of delivery, however, risk of loss shall pass to Buyer upon Seller's delivery to a carrier. Any delivery dates shown are approximate only and Seller shall have no liability for any delays in delivery.

**4. Warranty:** Seller warrants that the items sold hereunder shall be free from defects in material or workmanship for a period of: (A) All Power Take-Off units one (1) year from date of installation. (B) Except 267, 277, 278, 242, 244, 245, 250, 251 and 859 series two (2) years from date of installation.

**THIS WARRANTY COMPRISES THE SOLE AND ENTIRE WARRANTY PERTAINING TO ITEMS PROVIDED HEREUNDER. SELLER MAKES NO OTHER WARRANTY, GUARANTEE, OR REPRESENTATION OF ANY KIND WHATSOEVER. ALL OTHER WARRANTIES, INCLUDING BUT NOT LIMITED TO, MERCHANTABILITY AND FITNESS FOR PURPOSE, WHETHER EXPRESS, IMPLIED, OR ARISING BY OPERATION OF LAW, TRADE USAGE, OR COURSE OF DEALING ARE HEREBY DISCLAIMED. NOTWITHSTANDING THE FOREGOING, THERE ARE NO WARRANTIES WHATSOEVER ON ITEMS BUILT OR ACQUIRED WHOLLY OR PARTIALLY, TO BUYER'S DESIGNS OR SPECIFICATIONS.**

**5. Limitation Of Remedy: SELLER'S LIABILITY ARISING FROM OR IN ANY WAY CONNECTED WITH THE ITEMS SOLD OR THIS CONTRACT SHALL BE LIMITED EXCLUSIVELY TO REPAIR OR REPLACEMENT OF THE ITEMS SOLD OR REFUND OF THE PURCHASE PRICE PAID BY BUYER, AT SELLER'S SOLE OPTION. IN NO EVENT SHALL SELLER BE LIABLE FOR ANY INCIDENTAL, CONSEQUENTIAL OR SPECIAL DAMAGES OF ANY KIND OR NATURE WHATSOEVER, INCLUDING BUT NOT LIMITED TO LOST PROFITS ARISING FROM OR IN ANY WAY CONNECTED WITH THIS AGREEMENT OR ITEMS SOLD HEREUNDER, WHETHER ALLEGED TO ARISE FROM BREACH OF CONTRACT, EXPRESS OR IMPLIED WARRANTY, OR IN TORT, INCLUDING WITHOUT LIMITATION, NEGLIGENCE, FAILURE TO WARN OR STRICT LIABILITY.**

**6. Changes, Reschedules and Cancellations:** Buyer may request to modify the designs or specifications for the items sold hereunder as well as the quantities and delivery dates thereof, or may request to cancel all or part of this order, however, no such requested modification or cancellation shall become part of the contract between Buyer and Seller unless accepted by Seller in a written amendment to this Agreement. Acceptance of any such requested modification or cancellation shall be at Seller's discretion, and shall be upon such terms and conditions as Seller may require.

**7. Special Tooling:** A tooling charge may be imposed for any special tooling, including without limitation, dies, fixtures, molds and patterns, acquired to manufacture items sold pursuant to this contract. Such special tooling shall be and remain Seller's property notwithstanding payment of any charges by Buyer. In no event will Buyer acquire any interest in apparatus belonging to Seller which is utilized in the manufacture of the items sold hereunder, even if such apparatus has been specially converted or adapted for such manufacture and notwithstanding any charges paid by Buyer.

Unless otherwise agreed, Seller shall have the right to alter, discard or otherwise dispose of any special tooling or other property in its sole discretion at any time.

**8. Buyer's Property:** Any designs, tools, patterns, materials, drawings, confidential information or equipment furnished by Buyer or any other items which become Buyer's property, may be considered obsolete and may be destroyed by Seller after two (2) consecutive years have elapsed without Buyer placing an order for the items which are manufactured using such property. Seller shall not be responsible for any loss or damage to such property while it is in Seller's possession or control.

**9. Taxes:** Unless otherwise indicated on the face hereof, all prices and charges are exclusive of excise, sales, use, property, occupational or like taxes which may be imposed by any taxing authority upon the manufacture, sale or delivery of the items sold hereunder. If any such taxes must be paid by Seller or if Seller is liable for the collection of such tax, the amount thereof shall be in addition to the amounts for the items sold. Buyer agrees to pay all such taxes or to reimburse Seller therefore upon receipt of its invoice. If Buyer claims exemption from any sales, use or other tax imposed by any taxing authority, Buyer shall save Seller harmless from and against any such tax, together with any interest or penalties thereon which may be assessed if the items are held to be taxable.

**10. Indemnity For Infringement of Intellectual Property Rights:** Seller shall have no liability for infringement of any patents, trademarks, copyrights, trade dress, trade secrets or similar rights except as provided in this Part 10. Seller will defend and indemnify Buyer against allegations of infringement of U.S. Patents, U.S. Trademarks, copyrights, trade dress and trade secrets (hereinafter "Intellectual Property Rights"). Seller will defend at its expense and will pay the cost of any settlement or damages awarded in an action brought against Buyer based on an allegation that an item sold pursuant to this contract infringes the Intellectual Property Rights of a third party. Seller's obligation to defend and indemnify Buyer is contingent on Buyer notifying Seller within ten (10) days after Buyer becomes aware of such allegations of infringement, and Seller having sole control over the defense of any allegations or actions including all negotiations for settlement or compromise. If an item sold hereunder is subject to a claim that it infringes the Intellectual Property Rights of a third party, Seller may, at its sole expense and option, procure for Buyer the right to continue using said item, replace or modify said item so as to make it noninfringing, or offer to accept return of said item and return the purchase price less a reasonable allowance for depreciation. Notwithstanding the foregoing, Seller shall have no liability for claims of infringement based on information provided by Buyer, or directed to items delivered hereunder for which the designs are specified in whole or part by Buyer, or infringements resulting from the modification, combination or use in a system of any item sold hereunder. The foregoing provisions of this Part 10 shall constitute Seller's sole and exclusive liability and Buyer's sole and exclusive remedy for infringement of Intellectual Property Rights.

If a claim is based on information provided by Buyer or if the design for an item delivered hereunder is specified in whole or in part by Buyer, Buyer shall defend and indemnify Seller for all costs, expenses or judgments resulting from any claim that such item infringes any patent, trademark, copyright, trade dress, trade secret or any similar right.

**11. Force Majeure:** Seller does not assume the risk of and shall not be liable for delay or failure to perform any of Seller's obligations by reason of circumstances beyond the reasonable control of Seller (hereinafter "Events of Force Majeure"). Events of Force Majeure shall include without limitation, accidents, acts of God, strikes or labor disputes, acts, laws, rules or regulations of any government or government agency, fires, floods, delays or failures in delivery of carriers or suppliers, shortages of materials and any other cause beyond Seller's control.

**12. Entire Agreement/Governing Law:** The terms and conditions set forth herein, together with any amendments, modifications and any different terms or conditions expressly accepted by Seller in writing, shall constitute the entire Agreement concerning the items sold, and there are no oral or other representations or agreements which pertain thereto. This Agreement shall be governed in all respects by the law of the State of Ohio. No actions arising out of the sale of the items sold hereunder or this Agreement may be brought by either party more than two (2) years after the cause of action accrues.

9/01-P



**Parker Hannifin Corporation**

Chelsea Products Division

8225 Hacks Cross Road

Olive Branch, Mississippi 38654 USA

Tel: (662) 895-1011

Fax: (662) 895-1019

[www.parker.com/chelsea](http://www.parker.com/chelsea)

FP 01/05 1.5M