

ARB **AIR**

LOCKER

**AIR OPERATED
LOCKING DIFFERENTIALS**

INSTALLATION GUIDE



RD166

DANA 60, 35 SPLINE, 4.56 & UP

Part No. 2102166
Revision Date 23/07/2010
Copyright © 2009 by ARB Corporation Limited

1 Introduction

IMPORTANT :

BEFORE ATTEMPTING TO DISMANTLE YOUR VEHICLE FOR THIS INSTALLATION, PLEASE READ THIS INSTALLATION GUIDE IN ITS ENTIRETY, AS WELL AS ALL APPLICABLE SECTIONS OF YOUR VEHICLE MANUFACTURER'S SERVICE MANUAL.

1.1 Pre-Installation Preparation

This booklet is to be used in conjunction with your vehicle manufacturer's service manual. ARB endeavors to account for every possible variation in vehicle model when publishing its installation guides, and guides are updated regularly as new model information becomes available, however, the rapid and globally varied release of some vehicles makes it difficult to insure that your vehicle model has been accurately accounted for. In the case of any technical discrepancies between this guide and your service manual, we strongly advise that you adhere to the specifications and techniques as documented in your service manual.

Although your *ARB Air Locker* comes complete with all the step by step instructions you will need to supplement your vehicle manufacturer's service manual and install your new differential, ARB recommends that you have your *Air Locker* installed by a trained professional. Many ARB distributors around the world have been fully instructed in *Air Locker* installations by ARB, and have gained a wealth of experience and skill from years of performing similar installations.

Once you begin this installation your vehicle will be immobile until all steps of the installation are complete. Make sure your *Air Locker* kit is the correct model for your vehicle and that it contains all of the parts listed on back cover of this booklet. Also be sure you have appropriately equipped yourself with all the necessary tools, parts, and materials to complete this installation (see section 1.2 *Tool-Kit Recommendations*), and that you have allowed for an appropriate amount of vehicle down time.

HINT : Place a ✓ mark inside each of the symbols as you complete each step. It is very important NOT to miss any of the steps!



1 Introduction

1.2 Tool-Kit Recommendations

Below is a list of tools and supplies you may need to complete this installation. Requirements for your vehicle may vary. Please consult your vehicle service manual for additional recommendations.

1.2.1 Tools

- Standard automotive sizes (metric and/or imperial) of sockets, wrenches, Alan keys, and drills.
- A dial indicator or other suitable measuring tool for checking ring & pinion backlash.
- A standard automotive feeler gauge.
- A razor knife to cut the nylon tubing.
- A differential housing spreader, to facilitate removal of the carrier. (e.g., ARB Differential Spreader #0770003)
- A torque wrench. (See vehicle service manual for required torque range.)
- A lubricant drain reservoir.
- Suitable measuring tools to measure a differential for pre-load and/or backlash shimming. (See Section 3.2)
- A 11.2mm [7/16"] drill and ¼" NPT tap for bulkhead fitting installation.
- An automotive bearing puller (e.g., ARB Bearing Puller #0770001) or a differential carrier bearing puller.
- A bearing press or arbor press.

1.2.2 Supplies

- Thread lubricant/sealant compound for pressure fittings (e.g., LOCTITE #567 Teflon paste)
- Thread locking compound (e.g., LOCTITE #272)
- Either a replacement gasket, or gasket sealant, for your differential cover.
- A sufficient volume of differential oil to completely refill your housing. (see the *ARB Air Locker Operating and Service Manual* for recommended lubricants)
- A soap and water mixture to test for air leaks.



2 Removing the Existing Differential

2.1 Vehicle Support

- Safely secure the vehicle on a hoist. We recommend supporting the vehicle on a chassis hoist to keep the differential area at a convenient working height and to leave the wheels and axles free to be rotated and removed.
- Once supported off the ground, release the parking brake and leave the vehicle in neutral. Chock the wheels if necessary.

2.2 Differential Fluid Drain

HINT : This is a good time to check for metal particles in your oil, on your drain plug, or in the bottom of the housing which may indicate a worn bearing or differential component.

- Clean around the differential cover plate seal to prevent dirt from entering the differential.
- Position a fluid drain reservoir under the differential and loosen all differential cover plate retaining bolts.
- If a drain plug exists, remove it and completely drain all differential oil from the housing.
- If no drain plug exists then the oil can be drained by loosening the cover bolts and gently prying the cover away at the bottom until oil runs out.

HINT : If a drain plug does not exist then it would be a good idea to drill and tap for a tapered oil drain plug to assist with future oil changes.

- Once drained, remove the differential cover plate.

2 Removing the Existing Differential

2.3 Disconnecting the Axles

IMPORTANT :

Collision damage or heavy off-road use of your vehicle in the past may have resulted in some degree of bending in the axle. Any misalignment of the axle tubes may result in excessive wear and/or failure of your differential and axle shafts. ARB strongly recommends that you have your axle assembly inspected for concentricity and straightness before installing your *Air Locker*.

- Remove the wheels, and brakes according to your vehicle manufacturer's service manual.
- Remove both axle shafts according to your vehicle manufacturer's service manual.

NOTE : The axle oil seals are delicate and can be easily damaged. Support the weight of the axle shaft when drawing them out of their sockets in the housing.

2.4 Marking the Bearing Caps

- Using a pointed center punch, gently mark the bearing caps in a way that will enable you to know which cap is 'LEFT' and which cap is 'RIGHT', which way is 'UP' and which way is 'DOWN'. (Fig.1.)

HINT : Many installers choose to make one punch mark on the left hand side of the left hand bearing cap and one similar punch mark on the housing at close proximity to the cap mark. The right hand side is then designated with two punch marks on the right hand side of the cap and two similar punch marks on the housing.



2 Removing the Existing Differential

2.5 Checking the Current Backlash Amount

IMPORTANT:

This step is a precautionary measure recommended by ARB due to the fact that some after market ring and pinion sets have been manufactured to run with different backlash settings than those specified by your vehicle manufacturer. Although ARB must recommend you set backlash according to your service manual guidelines, we also advise that you compare the backlash measurements taken here to the recommended backlash settings in your vehicle service manual. Measurements found to be outside of your service manual recommendations may indicate the need to deviate from those settings in order to achieve quiet running with a good contact mark.

Refer to your vehicle service manual or your local authorized ARB installer for more information.

- Set a depth indicator on one of the ring gear teeth as in figure 2.

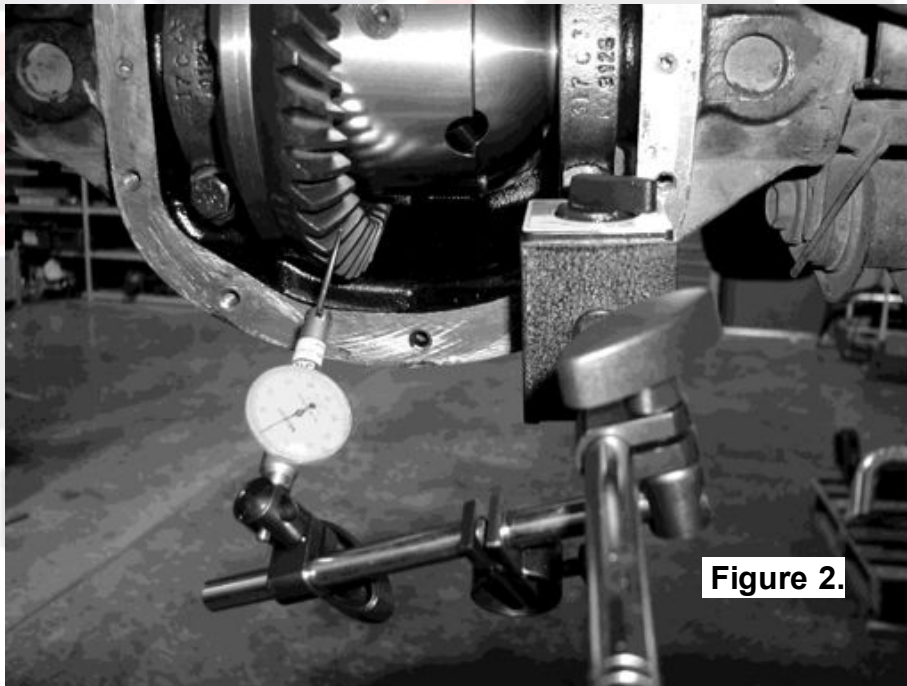

Figure 2.

- While supporting the pinion gear by holding the drive shaft flange, rotate the differential in both directions while observing the maximum variation in depth from the indicator (i.e., the highest value minus the lowest value). This value is referred to as the ring and pinion backlash.
- Rotate the differential center 90° and measure again for accuracy.
- Record the average of all measurements.

2 Removing the Existing Differential

2.6 Removing the Differential Center

IMPORTANT:

YOU MUST SPREAD THE HOUSING

Spreading the differential housing with a differential case spreader is a step which is critical to set up bearing pre-load (See Figure 3.). Improper pre-load will result in undue bearing wear, increased stresses in the differential center, increased running noise, and ultimately, ring and pinion gear damage.

- Remove both bearing caps.
- Carefully spread the housing (Fig.3.) enough to remove the differential center. (Refer to your vehicle's service manual).

NOTE : Do not spread the housing more than 0.50mm [0.020"].

HINT : Be sure not to mix up the left and right hand bearing cups. Later it will be necessary to know which cup came from which side.

- Once the housing has been adequately spread, the differential may be removed by pulling forward on the differential carrier.

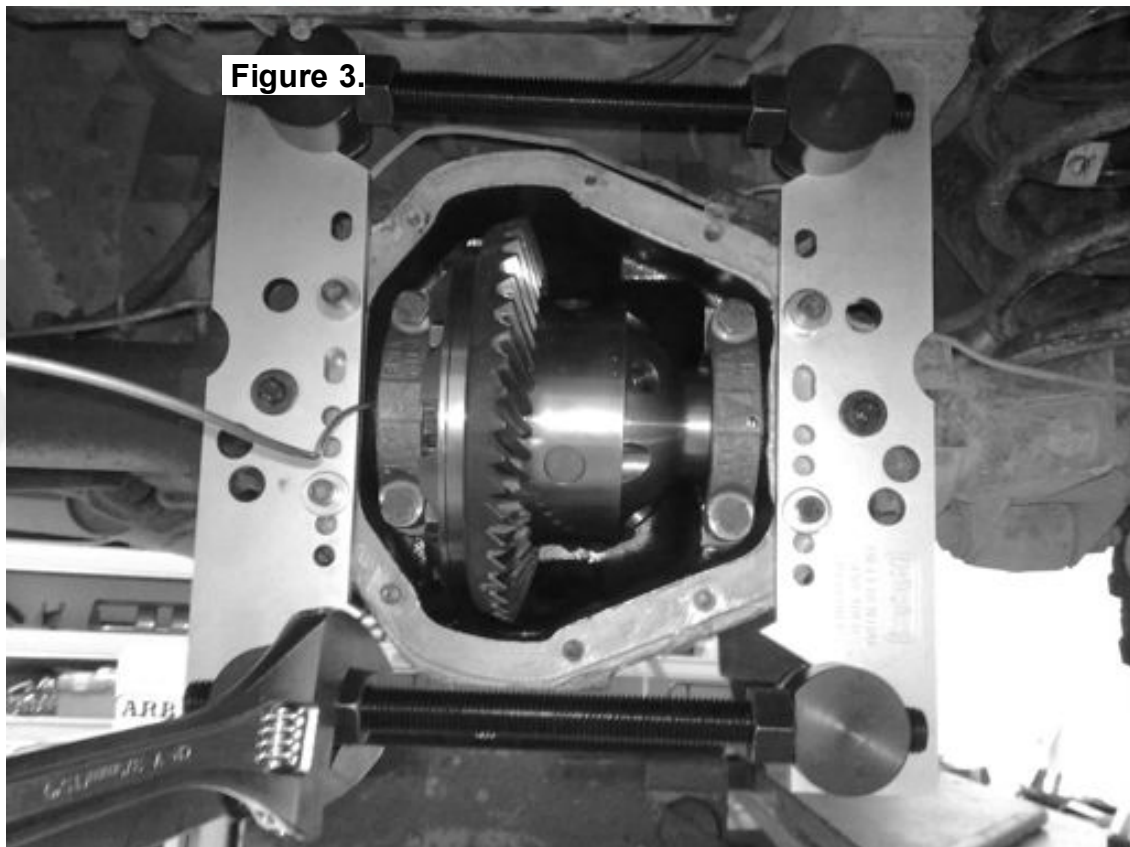

2 Removing the Existing Differential

NOTE : The differential center is heavy and quite difficult to handle when covered in oil. Take care not to drop it.

- Relieve any tension on the spreader immediately after the differential has been removed.



3 Installing the Air Locker

3.1 Insuring Adequate Oil Drainage

IMPORTANT:

Some Salisbury axles were manufactured with poor oil drainage between the axle tubes and the differential housing. This can often result in one of the axle tubes filling up with differential oil while running. In most cases this will result in a blocked air vent which will cause the differential housing to pressurize and expel oil from the axle seals at the wheels or force oil into the air system of the *Air Locker*, eventually expelling oil at the solenoid valve. This is a design flaw which was corrected by most automakers in the later releases of their axle assemblies. If no lower drainage point is present in the differential housing then it is critical that you modify the housing to include one.

- Inspect the differential housing for the presence of adequate drainage in both axle tubes (refer to Fig.4.).

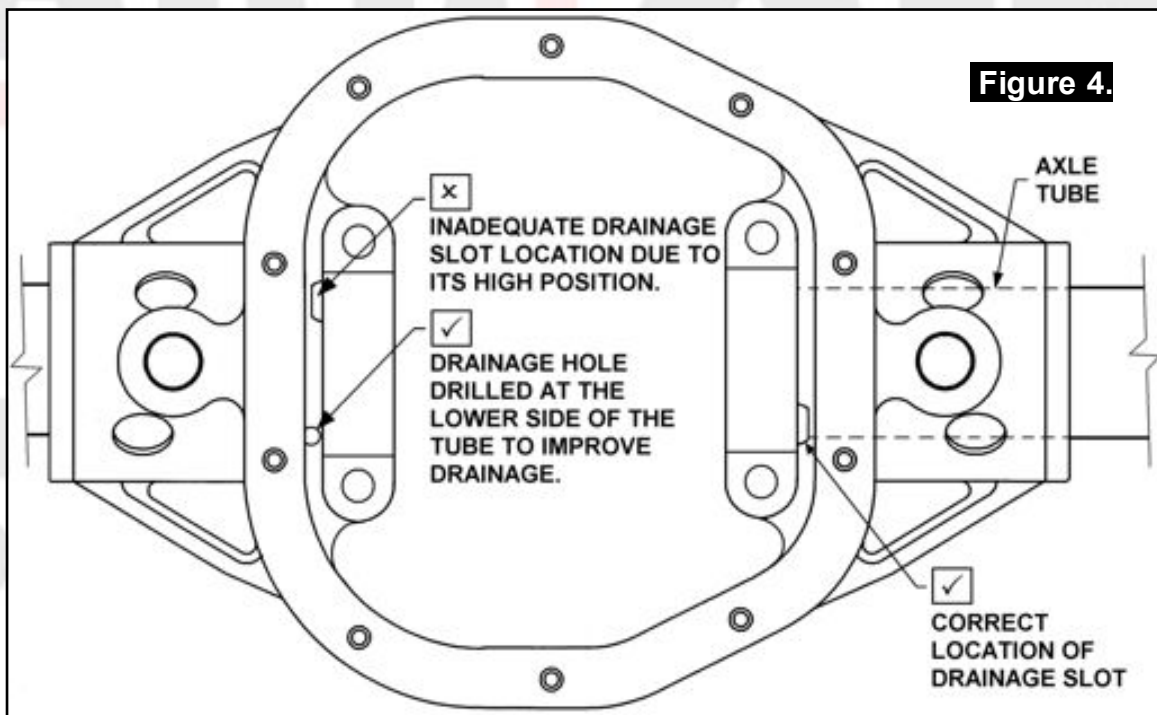

- If no drainage slot is present at the left-hand side (refer to Fig.4.) of the housing at all, then a slot will have to be created as clearance for the seal housing tube (Refer to Section 3.8 *Reinstalling the Bearing Caps*).
- If drainage exists but is inadequate then a slot or hole should be cut into the housing on the lower side of the tube(s) to allow oil out of the axle tube area.

3 Installing the Air Locker

NOTE : Make sure any grinding dust, filings or drill chips left behind by cutting the drainage slots is completely cleaned out of the housing.

- Check that the axle air vents are clear and working correctly.

3.2 Approximate Backlash Shimming

In order to reproduce a similar pre-load and ring and pinion backlash in your *Air Locker* to that of your original differential, measurements need to be taken so that a shim thickness can be calculated.

- Secure the original differential to a work bench.
- Remove the bolts that hold the ring gear in place.
- Using a plastic or copper hammer, tap in a circle around the ring gear to separate it from the differential carrier.

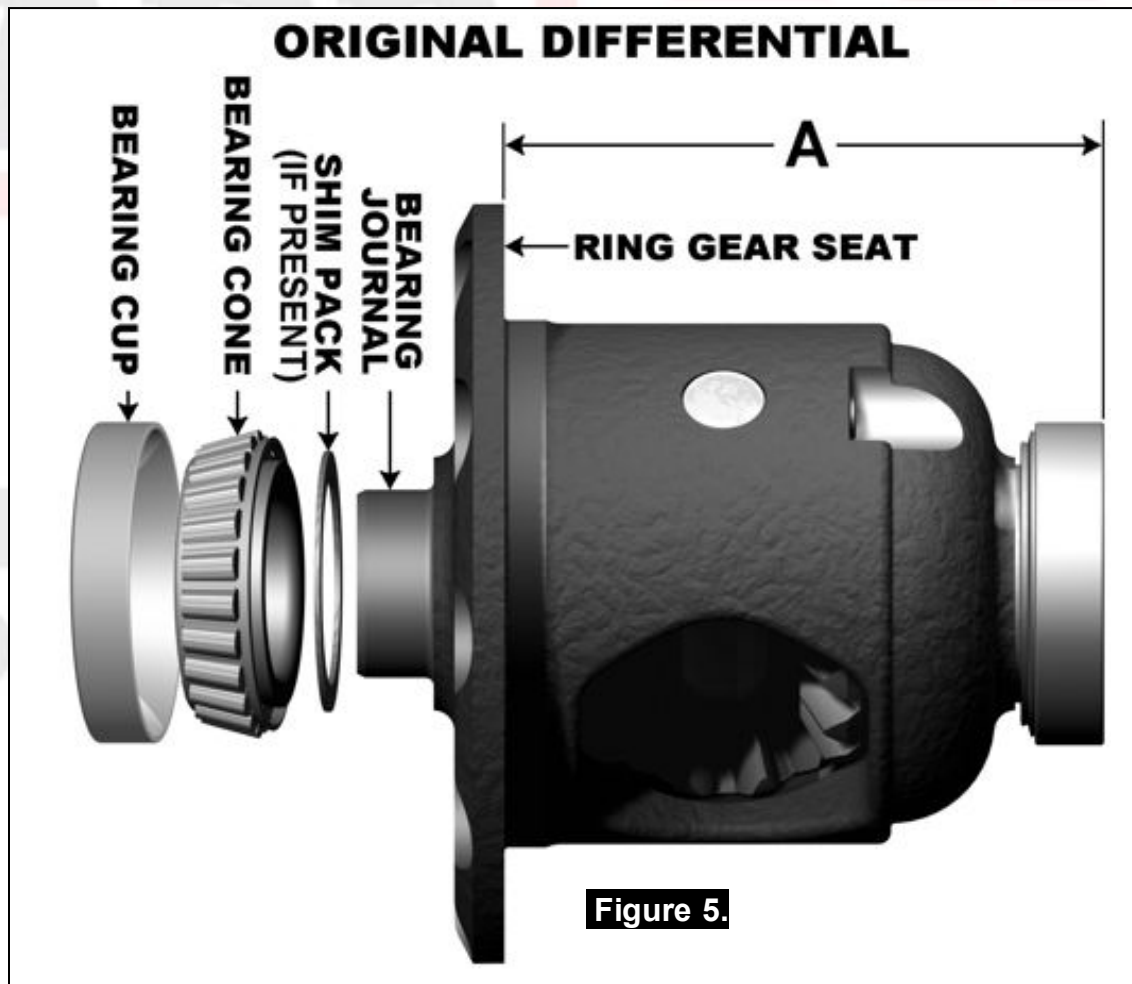

Figure 5.

- Assemble the original bearing cup onto the cone of the right-hand side of the original differential carrier.

3 Installing the Air Locker

- Using a caliper or similarly accurate measurement method (i.e., able to take accurate measurements within 0.04mm [0.0015"]), measure the distance from the shoulder of the outer face of the bearing cup to the ring gear mounting face (shown as 'A' in Figure 5.) and record this measurement as 'A'.

NOTE : Be sure to measure using the bearing cup that originally came off of the right-hand side.

- Remove the bearings from the original carrier using an automotive bearing puller (ARB #0770001). Inspect the bearings for wear or damage and replace if necessary.
- Apply a thin film of high pressure grease to both bearing journals of the *Air Locker* to prevent seizing.
- Using a bearing press or arbor press, press one of the bearing cones onto one bearing journal of the *Air Locker* (refer to Figure 6.) until the bearing seats firmly against the bearing journal shoulder.

NOTE : Do not add any shims between the bearings and the bearing seat, even if they were present on the OE carrier.

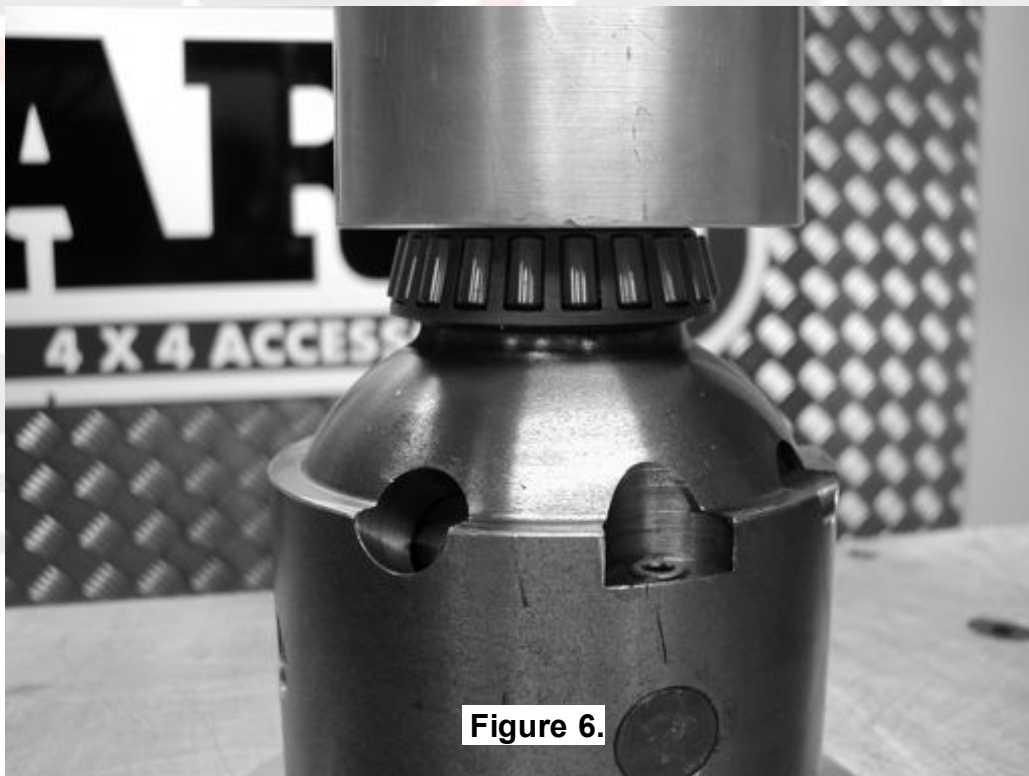

- Invert the *Air Locker* and press the other tapered roller bearing cone onto the opposite bearing journal of the differential carrier until the bearing seats firmly against the bearing journal shoulder.

3 Installing the Air Locker

- Assemble the new bearing cup onto the right-hand side of the *Air Locker* (as shown in Fig. 7.) and measure the total distance 'C'.

NOTE : The shim pack 'B' will be determined and added later.

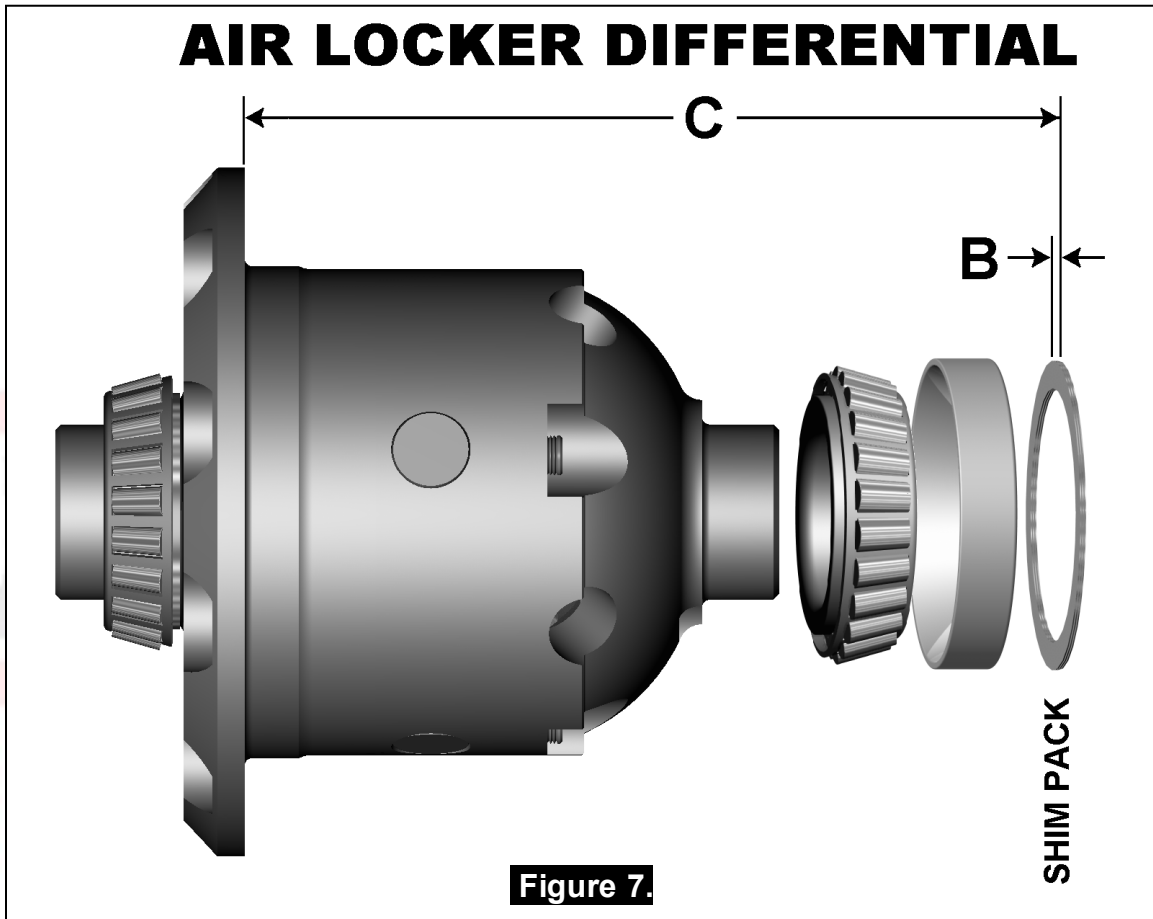

- Record this measurement as 'C'.

The thickness of the shim pack 'B' should make the distance 'C' on the *Air Locker* closely match the distance 'A' on the existing differential (within 0.1mm [0.004"]).

- Use the following calculation to find the desired thickness of 'B':

$$A - C = B \text{ (Replacement Shim Pack)}$$

HINT : If your calculations are correct then the following equation will also be true:

$$A - B - C = \text{ZERO}$$

3 Installing the Air Locker

- Select shims from the shim kit supplied with your *Air Locker* to make the thickness 'B' as determined above.

NOTE : If necessary, shim kit 'B' can be made from the standard Dana shims (not supplied) and put between the bearing cone and bearing seat.

- Place this shim pack on the bearing cup.
- Re-measure the new distance 'C' from the *Air Locker* (now including the shim pack 'B') to make sure that it matches 'A' on the original differential.

NOTE : NEVER machine the *Air Locker*.



3 Installing the Air Locker

3.3 Mounting the Ring Gear

- Apply a thin film of high pressure grease to the ring gear shoulder of the *Air Locker* to prevent seizing.
- Thoroughly clean any thread locking compound or other foreign matter from the holes of the ring gear, the threads of the ring gear bolts, and the mating surfaces between the ring gear and the *Air Locker* flange.

HINT : **Stoning the ring gear mounting face before installation will remove any high spots around the threads.**

- Heat the ring gear to between 80 and 100°C [175 - 212°F] in hot water or in an oven to slightly expand the gear and facilitate assembly.

NOTE : **NEVER HEAT GEARS WITH A FLAME! This could damage the hardened surface of the gear and result in premature wear or failure.**

- Dry the gear and bolt holes with compressed air (if wet).
- Install the ring gear onto the *Air Locker* by aligning the bolt holes and then gently tapping it around in a circle with a soft mallet. Avoid using the bolts to pull down the ring gear as this puts excess strain on the bolts and the differential flange.
- Apply a thread locking compound to the thread of each ring gear bolt before inserting it. Do not apply threading compound directly into the threaded hole as this could prevent the bolt from reaching its full depth.
- Tighten the ring gear bolts in a star pattern with a torque wrench according to your vehicle manufacturer's specified torque.

3 Installing the Air Locker

3.4 Drilling and Tapping the Bulkhead Port

An airline port must be drilled and tapped through the differential housing to mount the bulkhead fitting into.

NOTE : Higher ratio gearing uses deeper (thicker) ring gears with teeth that extend much further. Make sure the intended hole location is far enough away from the ring gear teeth that the air line will not be at risk of contact with the current or future ring gears.

- Mark a position on the top of the outside shell of the differential housing in either of the positions shown in Figure 8. Choose the position that is more suited to giving maximum clearance around the bulkhead fitting. The bulkhead position must allow the seal housing tube (assembled at a later time) to be clear of the ring gear position.

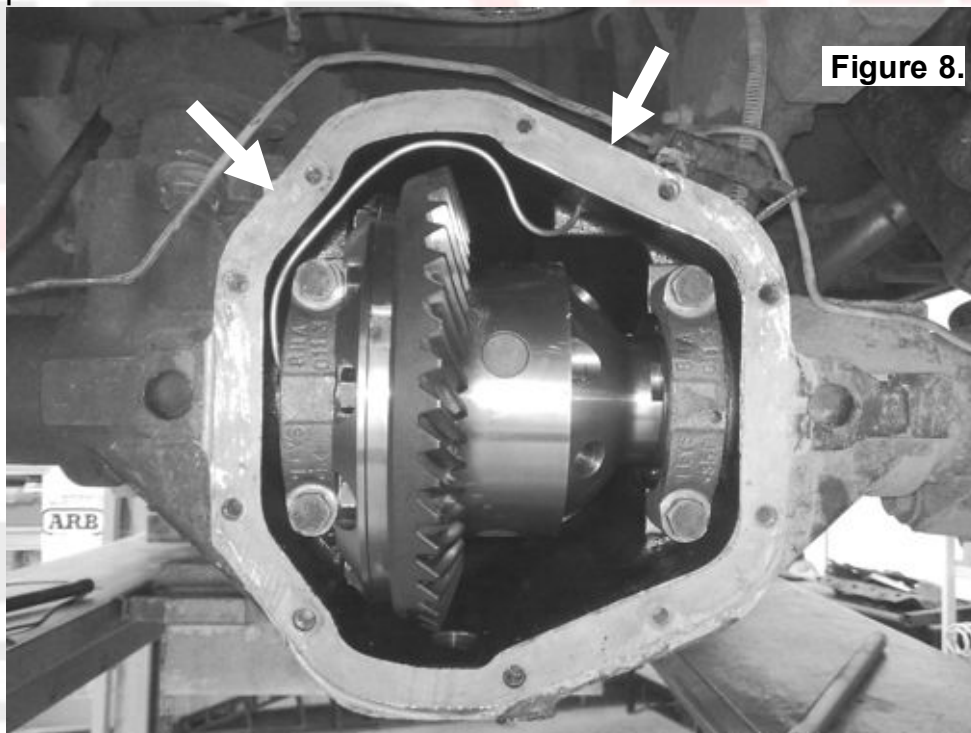

- Cover the drive pinion and axle tube areas with a rag to protect them from metal filings.
- Drill through the housing square to the outside surface using a 11.2mm [7/16"] drill.
- Tap the hole from the outside using a 1/4" NPT pipe tap.
- Remove any sharp edges from the hole that may chip-off and fall into the housing.
- Carefully remove the rags and inspect with a service light inside the housing to ensure no metal filings are left behind.

3 Installing the Air Locker

3.5 Assembling the Seal Housing

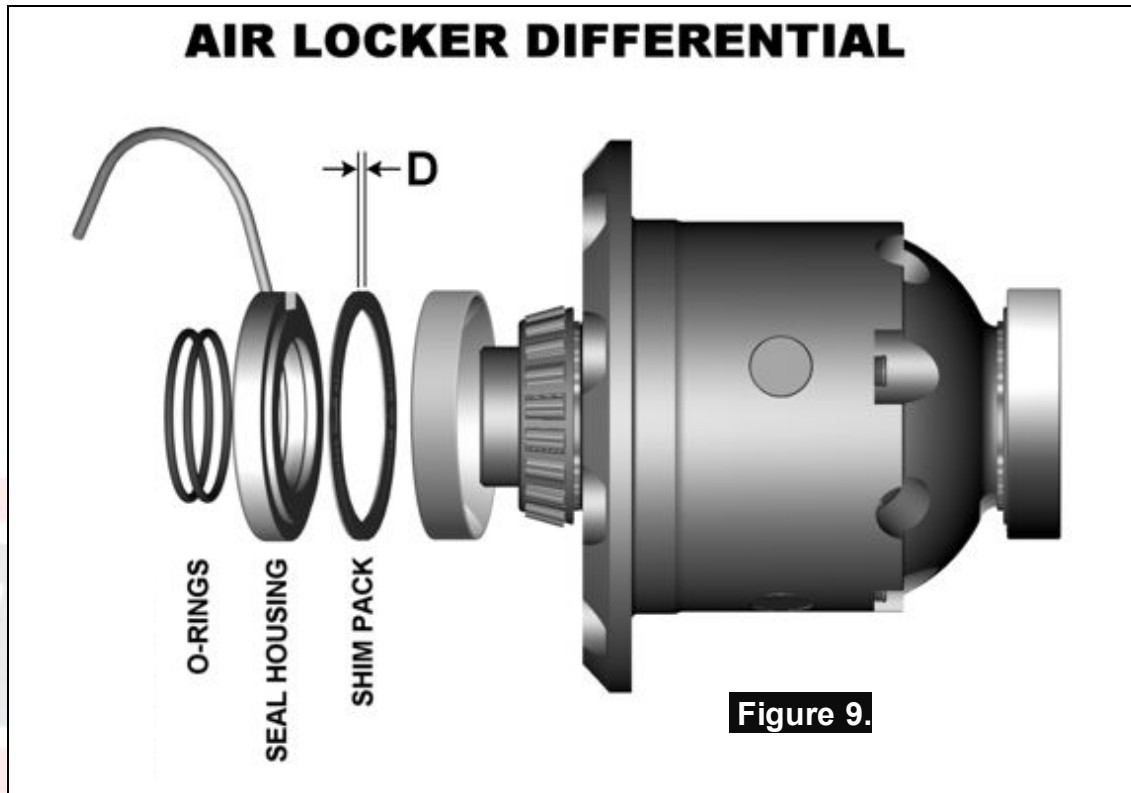

- Make sure the grooves and airway of the seal housing are clean and free from any contaminants (e.g. water, dirt, metal filings, etc.).
- Inspect the seal housing O-rings (supplied) for dirt, damage or other conditions which might cause leaks.
- Generously lubricate the O-rings with oil prior to assembly, then insert them into the grooves of the seal housing.

NOTE : When assembling the O-rings, be careful not to leave them twisted when seated in the grooves as this could cause excessive wear and leakage.

- Lubricate the seal housing running surface on the *Air Locker* carrier with oil. Assemble a bearing cup onto the left-hand side of the *Air Locker*.
- With the stepped side towards the bearing, carefully install the seal housing by sliding it all of the way onto the bearing journal with a gentle twisting motion. This will allow the O-rings to engage gently.

IMPORTANT :

A 4mm Master Shim is supplied for use with the "thin" bearing cup (382A). Do not use this shim with the "thick" bearing cup (382-S).

3 Installing the Air Locker

3.6 Pre-Load Shimming

In order to pre-load the tapered roller bearings in your *Air Locker*, measurements need to be taken so that a value can be calculated for the shim thickness 'D' in Figure 9.

- Insert and hold the *Air Locker* into the differential housing.
- Insert the shim pack determined earlier as 'B' between the bearing cup (right-hand side) and the axle housing.
- Push (or lightly pry) the *Air Locker* hard across to the right-hand side, and measure the maximum gap (also called the 'end float') between the outside of the seal housing and the inside face of the axle housing with an automotive feeler gauge. (Fig.10.)



Figure 10.

- Consult your vehicle manufacturer's service manual to determine the carrier bearing pre-load amount specified for your vehicle.
- Add the specified pre-load amount to the measurement taken with the feeler gauge to determine a shim amount for 'D' in Figure 9.

PRE-LOAD + END FLOAT = SHIM PACK

- Create a shim pack 'D' from the shims supplied with your *Air Locker*.

NOTE : A wide variety of shims has been included in the shim kit for your convenience and to cover various Dana 60 applications, however it should not be necessary to use them all.

3 Installing the Air Locker

NOTE : Do not add shims between the bearing cone and the bearing seat of the seal housing side and **NEVER** machine the *Air Locker*.

- Remove the *Air Locker* from the axle housing.
- Install the shim pack 'D' between the bearing cup and the seal housing as shown in Figure 9.
- Spread the differential housing again (Refer to Section 2.6).
- Re-install the *Air Locker* into the axle housing.

NOTE : If the *Air Locker* is too tight to fully install then the spreader tension may need to be increased. **Do not spread the housing more than 0.50mm [0.020"]**.

NOTE : Use the ARB Shim Driver #0770004 to install the supplied *Air Locker* shims.

- Rotate the seal housing until the tube is pointing straight out of the axle housing.
- Release all spreader tension.
- Check that some backlash can be felt between the ring and pinion gears. No backlash would be an early indication of incorrect shim thickness.

3 Installing the Air Locker

3.7 Reinstalling the Bearing Caps

- Install the bearing caps oriented as they were marked before they were removed, and tighten the bearing cap bolts. It is not necessary to torque them down at this time.
- Check that some clearance exists between the bearing cap and the seal housing tube. If not, the bearing cap should be removed and the tube re-bent for adequate clearance.
- Tighten all bearing cap bolts with a torque wrench to the torque specified in your vehicle manufacturer's service manual.



3 Installing the Air Locker

3.8 Checking the Backlash

- Set a depth indicator on one of the ring gear teeth as in Figure 11.
- While supporting the pinion gear by holding the drive shaft, rotate the differential in both directions while observing the maximum variation in depth from the indicator (i.e., the highest value minus the lowest value). This value is referred to as the ring and pinion backlash.
- Rotate the differential center 90° and measure again for accuracy.

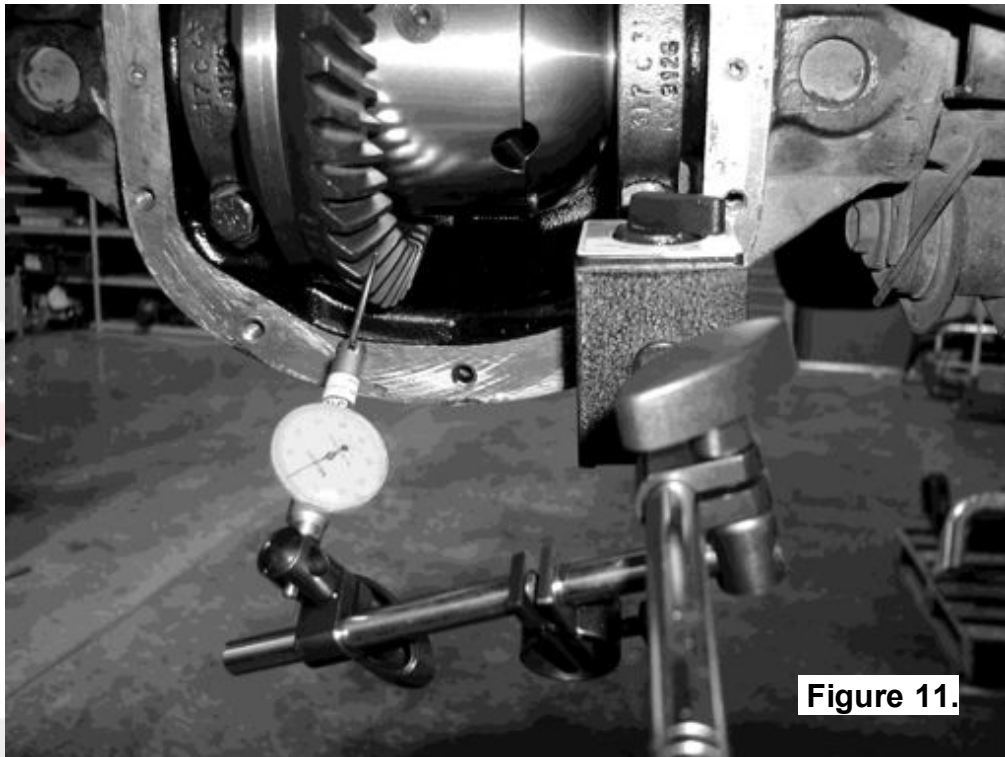

- Refer to your vehicle service manual for the specified maximum and minimum amounts of backlash. If the backlash is not within the specifications then the differential will have to be removed and re-shimmed.

3.8.1 Re-Shimming the Backlash

NOTE : This step is only necessary when adjusting for incorrect backlash.

- Remove the bearing caps.
- Remove the differential as before.
- To decrease the amount of backlash, reduce the shim thickness 'B' (Fig.7.) and increase the shim thickness 'D' (Fig.9.) by the same amount. Reverse this step to increase the backlash.

3 Installing the Air Locker

- Remount the differential as before.
- Release spreader tension (if applicable).
- Check backlash again as before.

3.9 Setting Up the Bulkhead Fitting

- Apply thread sealant to the threads of the bulkhead body.
- Screw the bulkhead body into the tapped hole, and tighten.
- Wipe the area clean of any excess thread sealant (inside and outside of the housing).
- Bend the seal housing tube to the approximate shape (Fig. 12.), and trim to length using an automotive tube cutter.
- Insert the free end of the seal housing tube into the bulkhead fitting until it protrudes approximately 8mm [5/16"] through the other side.
- From the outside of the housing, assemble the small O-ring over the top of the short length of seal housing protruding through the bulkhead fitting.
- While still holding the seal housing tube into the bulkhead fitting, insert the small drilled end of the center compression nut over the extended tube as shown in the assembly diagram (Fig.13.), and screw it into the bulkhead body, and lightly tighten.

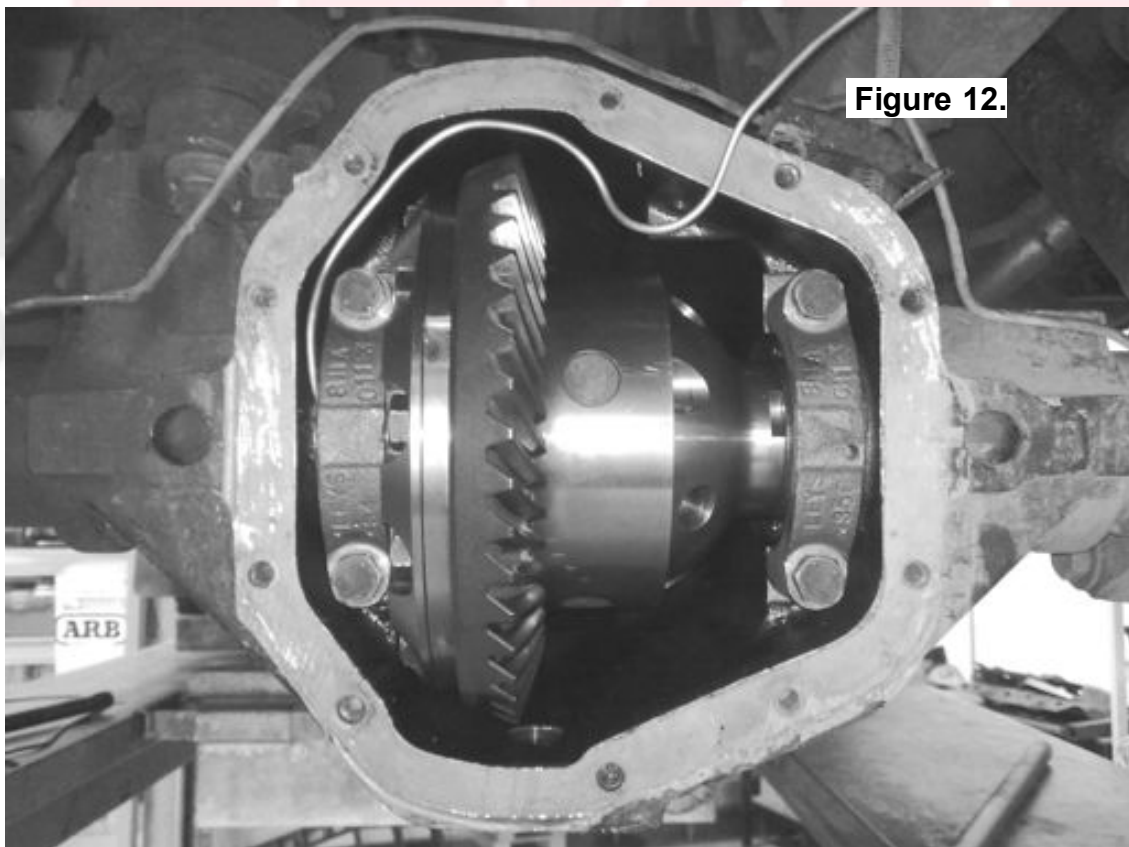

3 Installing the Air Locker

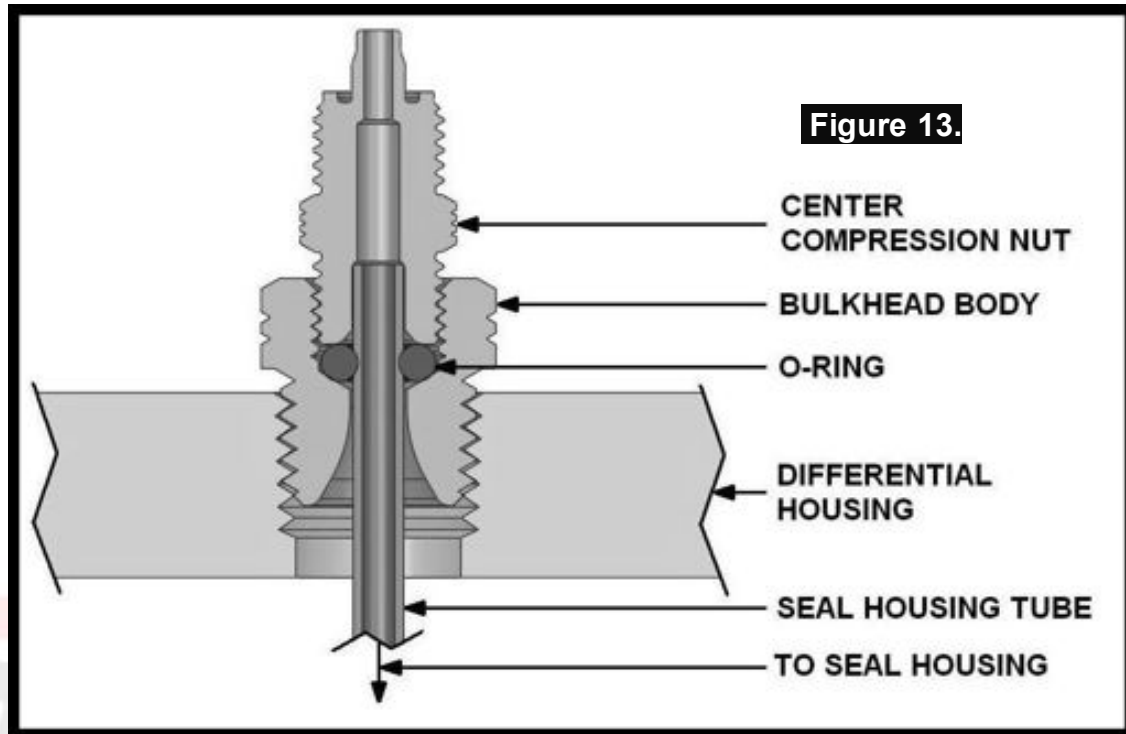

NOTE : Excessive tightening of the center compression nut is not necessary to form a good seal around the tube and may damage the O-ring, the seal housing tube, or the threads of the compression nut.

NOTE : Make sure the seal housing tube is all of the way into the center compression nut while you are tightening it.

3 Installing the Air Locker

3.10 Profiling the Seal Housing Tube

- Completely remove the differential spreader.
- Without using sharp, jagged tools such as pliers (usually your hands are the best tool for this job), gently bend the seal housing tube so that it runs along the inside of the differential housing as shown in Figure 14.

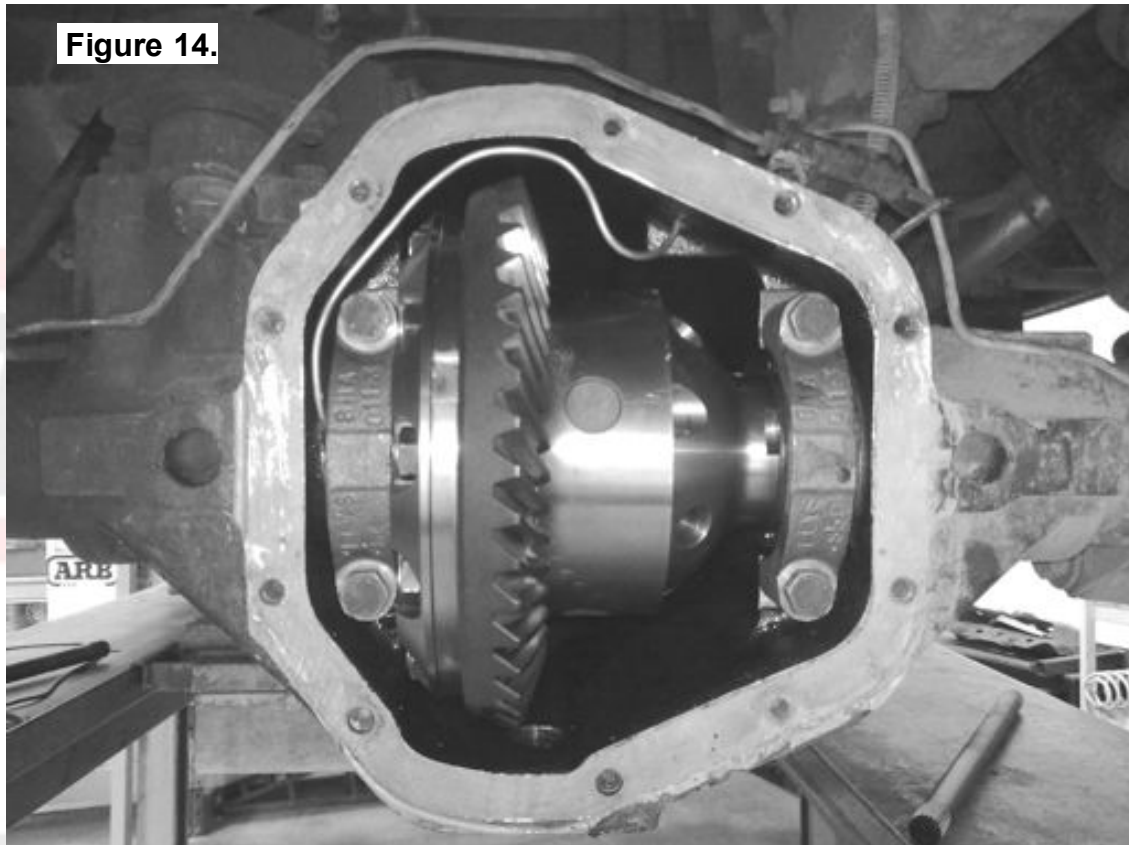

NOTE : It is also a good idea to keep the tube away from the bearing caps or any other part of the differential casting as any contact due to vibration or shock may wear the tube and eventually cause a leak.

3 Installing the Air Locker

3.11 Bench Testing the Air Locker

- To test the *Air Locker*, when 620kPa [90 PSI] shop air is applied to the seal housing tube, the *Air Locker* should engage.
- Check all fittings and the seal housing for air leaks.
- Rotate the differential carrier by turning the pinion flange whilst applying air pressure.

NOTE : An accurate way to test for air leaks is to fit a shut-off valve to an air pressure gauge (ARB part # 0770005). Once 620 KPA [90 PSI] is reached close the valve, disconnect the air hose, and watch to see if there is any drop in pressure. If so, this will indicate an air leak. (Fig.15.)

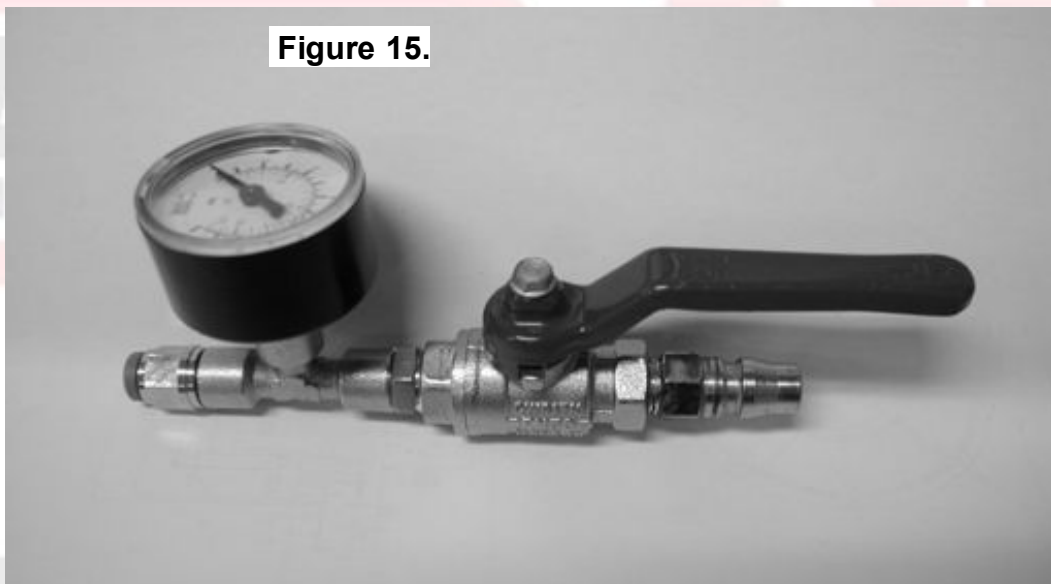

- If a leak is found to be present, spray a soap and water mixture onto the bulkhead air fitting. Bubbles should appear at any leak points.

NOTE : Do not spray this soapy mixture inside the differential.

- Check that leaky fittings have been adequately tightened.
- Disassemble, clean threads, and reapply thread sealant if leaking persists.

If a leak is found at the seal housing, carefully remove the seal housing assembly and examine the O-rings. Be very careful with the O-rings and check for defects, damage, wear, or presence of foreign material in the O-ring grooves. Replace if necessary.

4 Installing the Air System

4.1 Mounting the Solenoid

4.1.1 Connection to an ARB Air Compressor (Fig.16.)

- Remove one of the 1/8" BSP plugs from its port in the compressor tank.
- Apply Teflon paste to the nipple (1/8" X 1/8" BSP) and insert it into the port and tighten.
- Apply Teflon paste to the free end of the nipple.
- Assemble the inlet port side of the solenoid (stamped with a '1') onto the nipple and tighten. The solenoid should be rotated into a position that does not obstruct any other ports on the compressor tank.

NOTE : The solenoid exhausts compressed air through the center of the black retaining cap when the *Air Locker* is disengaged. Make sure this orifice cannot be obstructed.

- Apply Teflon paste to the threads of the 5mm push-in fitting and assemble it into the solenoid outlet port (stamped "2") and tighten.

ARB

Air Compressor

Figure 16.

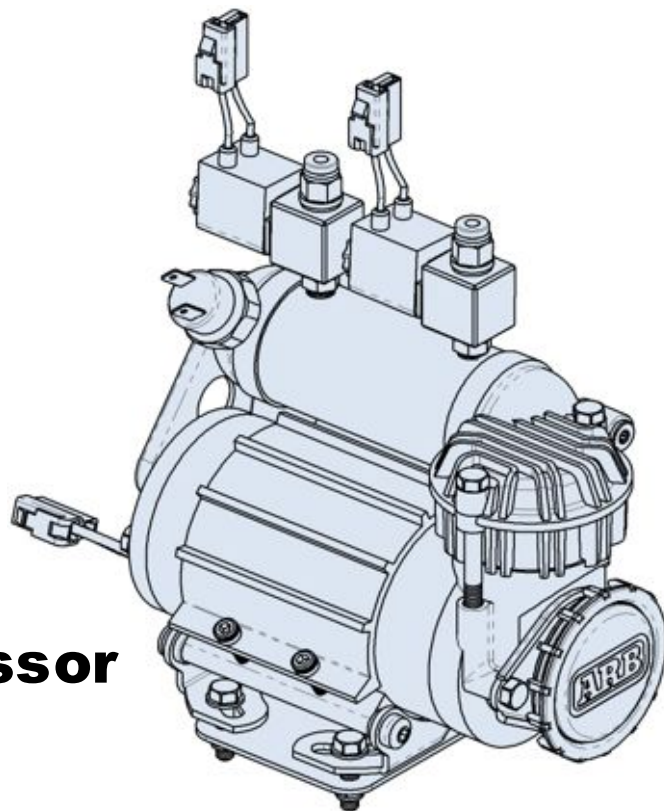

4 Installing the Air System

4.1.2 Connection to an Alternate Air Source

For ease of installation, quality of air supply, and a high level of dependability from your *Air Locker(s)*, ARB strongly recommends use of a genuine ARB Air Compressor, however, the *Air Locker* air system can be operated on any alternate air source that meets each of the following guidelines:

- Must supply a minimum of 85PSI [586kPa].
- The supply must never exceed 105PSI [724kPa].
- The Air source should have a tank capacity that enables it to actuate the *Air Locker(s)* in one charge so that no hesitation is experienced when locking one or two differentials.

HINT : A good way to insure that you have the necessary capacity is to make sure you can engage, disengage, and then reengage your *Air Locker(s)* without the air source having to regenerate (e.g., without the compressor turning on to refill the tank).

- Must supply clean air, free of rust, dirt, water, or other foreign matter.
- Must match the 1/8" BSP porting of the *Air Locker* solenoid.
- Mount solenoid within close proximity of the air supply and secure it from the effects of vibration and shock.
- Connect the air supply to the 1/8" BSP inlet port of the solenoid (stamped "1" on the solenoid body) using thread sealant.

IMPORTANT :

ARB cannot warrant your *Air Locker(s)* against damage caused as a result of using an alternate air supply. If you have any doubts as to the suitability of your air system to use in an *Air Locker* system, consult your ARB distributor.



4 Installing the Air System

4.2 Running and Securing the Air Line

The path taken by the air line from your air source (i.e., compressor) to your *Air Locker* is unique to your vehicle and the position of your air source. Plan ahead carefully when running the air line and always follow these guidelines:

- Account for axle travel when running the line from the axle to a fixed point on the vehicle. Leave enough slack in the air line to allow for maximum suspension travel in both directions.
(Not necessary on IFS installations)
- Avoid leaving large lengths of air line hanging underneath the vehicle where they may get tangled on rocks, sticks, etc.

HINT : Cable tying the air line to one of your flexible brake lines will account for axle travel and should help keep your line from getting snagged.

- Run the air line all the way from the compressor to the differential before trimming either end of the line to length. This will save complications that may arise if the air line has to be removed.
- Make sure the line does not contact sharp edges or abrasive surfaces that may damage the air line over time.
- Do not run the air line around tight bends which may kink the air line and restrict or block the air flow.
- Keep the air line well away from your vehicle's exhaust components. Air lines will melt if subjected to extreme heat.
- Do not run more air line than necessary. Excess line volume created when coiling the left over hose, using unusually large diameter hose, etc., will increase drain on the compressor tank resulting in the compressor running more often than needed.
- Support the air line by tying it back with cable ties wherever possible.
- At the solenoid end of the air line, always trim the line to length with a sharp knife to avoid distorting the tube where it plugs into the push-in fitting.

NOTE : To remove the air line from the push-in fitting; while holding the flange of the fitting out, push the air line into the fitting as far as possible, then press the flange inward, then pull the air line free of the fitting.

4 Installing the Air System

- To attach the air line to the push-in fitting of the solenoid; insert the line firmly into the fitting, pull outward on the flange of the fitting while holding the line as far into the fitting as possible, and then gently pull outward on the air line to clamp the line in place.

4.3 Connection to the Bulkhead Fitting

- In the case of an IFS axle assembly or in the case that the axle assembly has been completely removed from the vehicle, the assembly will have to be remounted in order to position the bulkhead fitting in its correct location for air line access.
- Trim the air line to length using a sharp knife.
- Insert the support spring over the end of the air line - small end first. (Fig.17.)
- Insert the outer compression nut over the air line.
- Push the airline onto the barb on the center compression nut, ensuring that it is pushed all the way to the end.

Figure 17.



- HINT :** If the tube is too difficult to push on, place the end of the air line into a cup of boiled water to soften the tubing.

4 Installing the Air System

- Screw on the outer compression nut and tighten, while supporting the center compression nut with a 3/8" spanner. The airline is now attached to the center compression nut.

NOTE : The outer compression nut will tighten against a stop. Over tightening will not create a better seal.

- Assemble the support spring over the outside of the outer compression nut.
- Secure any loose sections of tube with a cable tie.



5 Mounting & Connecting the Electrical System

5.1 Mounting the Actuator Switch(es)

Air Locker actuator switch(es) can be easily panel mounted inside the vehicle in a 21mm x 36.5mm [0.83" x 1.44"] rectangular cutout.

NOTE : Only attach the cover plate to the face of the switch once the switch has been mounted and wired correctly as the cover plates are designed to be difficult to remove.

For reasons of safety and for ease of operation, the *Air Locker* actuator switch(es) should be mounted in a location picked to best suit the operator. Make sure you have taken the following points into consideration:

- Switch(es) MUST be mounted and should never be allowed to simply dangle from the wiring loom during vehicle use.
- Switch(es) should be within easy reach of the driver. Ideally, any *Air Locker* switch should be able to be operated without physical effort or distraction to the driver.
- Switch(es) should be mounted within the line of sight of the driver so that switch position ('ON' or 'OFF') can be visually determined by the rocker position and the illumination state.
- The position of the switch(es) should best eliminate any possibility of accidental operation by the driver or one of the passengers.
- Switch cutout position(s) must be located in an area with a minimum of 50mm [2"] of clearance behind the face of the cutout.
- Switch(es) should not be mounted where they will be exposed to water (e.g., in the lower section of an inner door panel).
- ARB recommends that you apply the *Air Locker* Warning Sticker (ARB part # 210101) within close visual proximity of the switch location.

NOTE : If no adequate position can be found on existing dashboard panels, a surface mounted bracket (Fig. 18.) may be purchased from your ARB *Air Locker* distributor to suit 1, 2, or 3 switches.

5 Mounting & Connecting the Electrical System

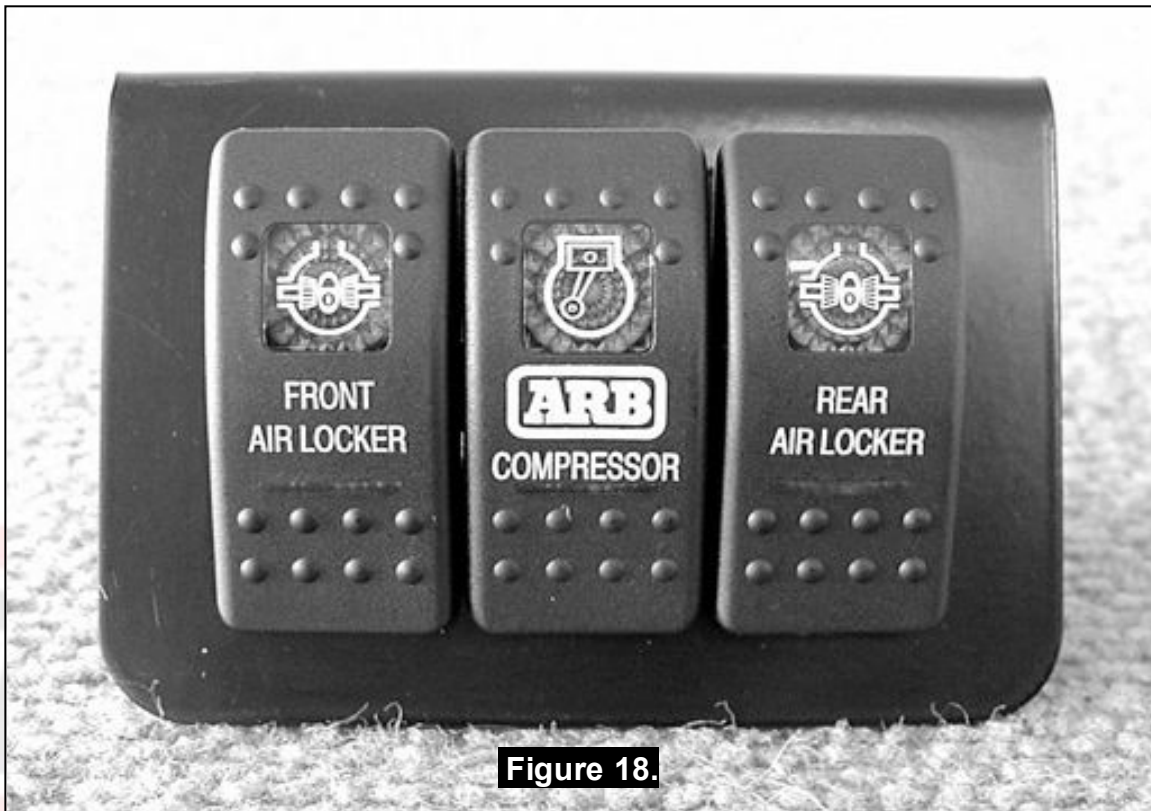

Figure 18.

5.2 Wiring the Actuator System

5.2.1 Connection to an ARB AIR COMPRESSOR

When wiring the *Air Locker* actuator switch(es) and solenoid(s) to an ARB Air Compressor, all connections can easily be set up directly from the supplied wiring loom. (Fig. Error! Reference source not found.)

NOTE : 180409 model loom shown for reference only. Refer to your ARB Air Compressor Installation Guide for details on configuring your installation.

5 Mounting & Connecting the Electrical System

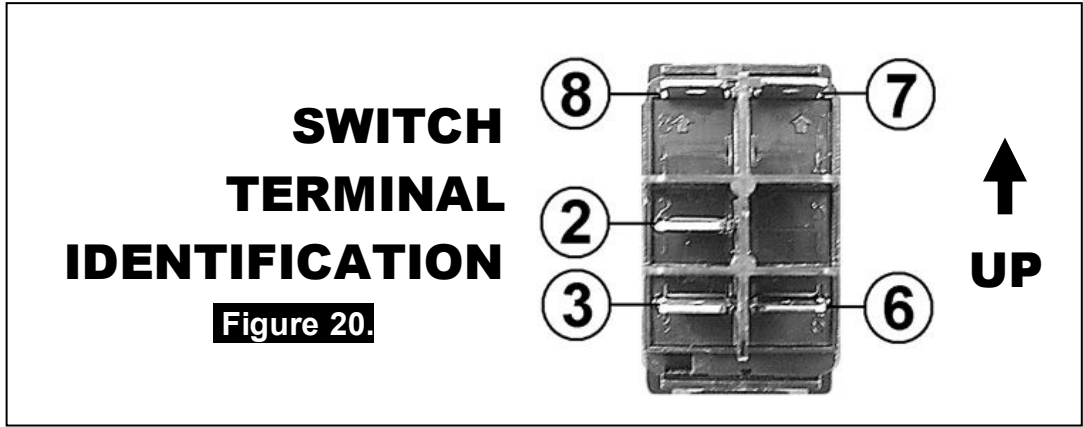
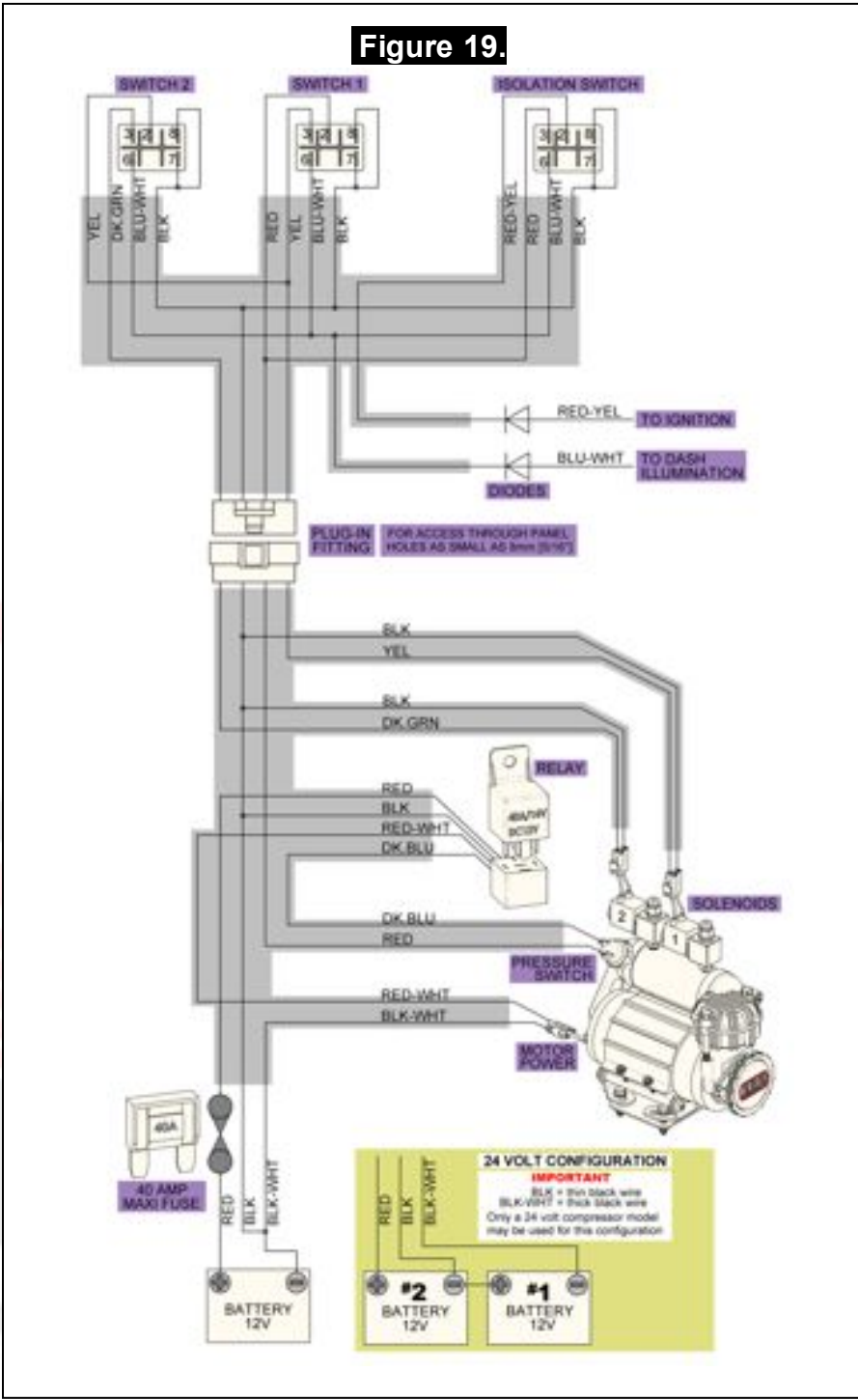

5 Mounting & Connecting the Electrical System

5.2.2 Connection to an Alternate Air Source

When connecting the actuation switch to an alternate air source, the switch(es) should be wired according to figures 21. and 22., depending on whether one or two *Air Lockers* will be installed in the vehicle.

5.2.2.1 Single Air Locker System

- If only one *Air Locker* is to be installed in the system, the switch and solenoid should be wired according to figure 21. regardless of whether the *Air Locker* has been installed in the front or rear axle of the vehicle.
- Attach the appropriate switch cover (i.e., 'FRONT' or 'REAR') to the switch.

NOTE : Refer to Figure 20. for the correct switch terminal identification and switch orientation.

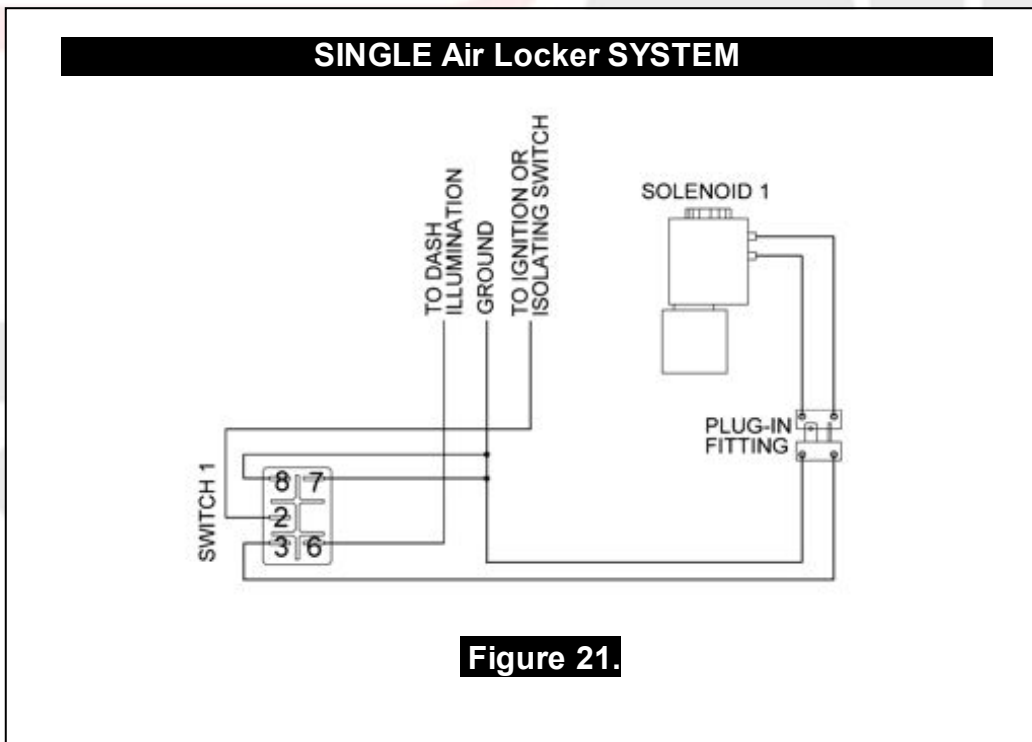

5 Mounting & Connecting the Electrical System

5.2.2.2 Dual Air Locker System

- If two *Air Lockers* are to be installed in the system, ARB recommends that the switches and solenoids be wired according to figure 22. For safety reasons, this configuration allows SOLENOID 2 to be actuated only if SOLENOID 1 is already on.
- Attach the “REAR AIR LOCKER” switch cover to SWITCH 1, and the “FRONT AIR LOCKER” switch cover to SWITCH 2.

NOTE : Refer to Figure 20. for the correct switch terminal identification and switch orientation.

- Configure SOLENOID 1 as the air line leading to the rear axle *Air Locker*, and SOLENOID 2 as the air line leading to the front axle *Air Locker*.

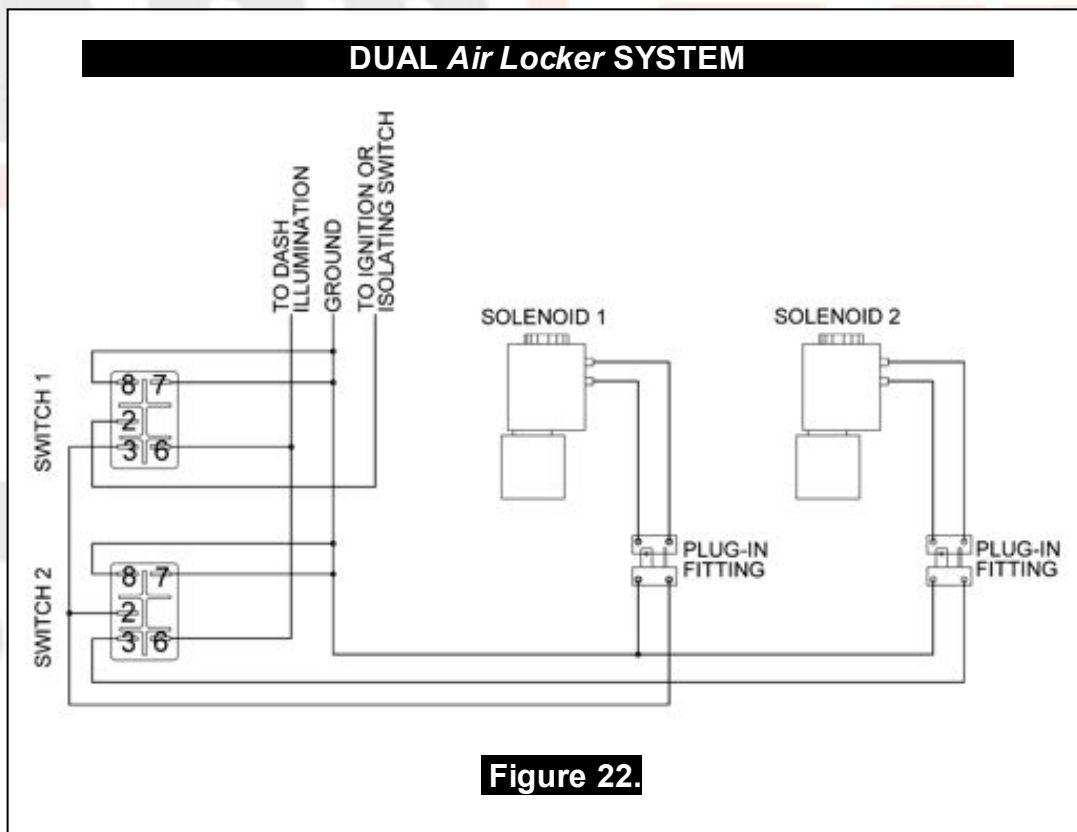

6 Testing & Final Assembly

6.1 Leak Testing

- With the vehicle parked and the engine off, turn the compressor on and wait until the air system is fully charged.

NOTE : With the *Air Locker(s)* disengaged, the air source (i.e., compressor) should not have to recharge over time. Intermittent recharging without *Air Locker* use usually indicates a leak at the solenoid fittings or at the compressor tank O-ring seal.

- Actuate the *Air Locker(s)*.
- The compressor should not come on again for a period of at least 15min. Air system recharging within that time period would indicate that a leak is present in the system.

NOTE : If an alternate air source (e.g., an air cylinder or a belt driven air pump) is used instead of a compressor, the air system will have to be leak tested with a pressure gauge and a shut-off valve in series before the solenoid input.

- If a leak is found to be present, spray a soap and water mixture onto all air fittings in the system while the compressor is fully charged. Bubbles should appear at any leak points.
- Check that leaky fittings have been adequately tightened.
- Disassemble, clean threads, and reapply thread sealant if leaking persists.

6.2 Reinstalling the Axles

- Insert both axles fully into the housing and gently tap them inward.

NOTE : Be careful not to damage the axle oil seals with the spline of the axle.

- Reconnect the drive shaft to the differential drive flange.
- Reassemble the remainder of the differential assembly (e.g., hubs, brakes, wheels, etc.) to the vehicle according to your vehicle's service manual.

6 Testing & Final Assembly

6.3 Testing the Air Locker Actuation

To test that your air system, electrical system, and your *Air Locker* differential is functioning correctly:

- Support the vehicle such that the wheels are free to rotate (e.g., on axle stands, a chassis hoist, etc.)
- Leave the parking brake off, the transmission in neutral, and the *Air Locker* switch 'OFF'.
- Turn the ignition to the 'ON' position (leaving the motor off). The large illuminating symbol on the *Air Locker* switch cover should be 'OFF'.
- Turn the compressor (or alternate air source) on to charge the air supply up to its maximum pressure.
- While supporting the drive shaft flange, rotate one wheel by hand.
- The wheel should rotate freely and the opposite wheel should be turning in the opposite direction without any resistance or mechanical noise from within the differential.
- Turn the *Air Locker* switch to the 'ON' position. The illuminated symbol on the switch cover should light up.
- Rotate the same wheel again.
- Both wheels should rotate together.
- Turn the switch off again.
- Rotate the same wheel.
- The wheels should again rotate in opposite directions.

6.4 Re-Sealing & Filling the Differential

NOTE : Consult the *ARB Air Locker Operating & Service Manual* for recommendations on differential lubricant specifications.

- Replace the differential cover using gasket sealant or a new standard differential cover gasket for your make of vehicle.
- Refill the differential until level with the filler hole.
- Rotate the differential center 2 full turns.
- Check the oil level and add oil if necessary.
- Replace filler plug (apply thread sealant to filler plug before inserting if it is a threaded type plug).
- Wipe differential housing clean of any oil or grease which may collect dirt or other abrasive particles.

6 Testing & Final Assembly

6.5 Post-Installation Check List

Now that the *Air Locker* installation has been completed, ARB recommends that you take the time to complete the following check list just to insure that you haven't missed any of the vital steps.

- The air system has been leak tested.
- Thread locking compound was used on the ring gear bolts.
- All torque settings comply with the vehicle manufacturer's specs and were set with an accurate torque wrench.
- Differential fluid complies with ARB recommendations and has been filled to the correct level.
- All air lines and wiring have been securely cable tied to resist snagging.
- Switch(es) have been securely mounted within operator reach, yet well away from danger of accidental engagement.
- Switch(es) function properly and illuminate to indicate that *Air Locker(s)* are engaged.
- All operators who are to use the *Air Locker* have read, and fully understand the *ARB Air Locker Operating & Service Manual*.
- The *Air Locker* Warning Sticker has been located within close proximity of the actuator switch(es).

INSTALLATION PERFORMED BY: _____

DATE OF INSTALLATION: _____

ODOMETER READING: _____

ARB AIR LOCKER SERIAL No: _____



7 Parts List

7.1 Exploded Assembly Diagram

(See itemized parts list overleaf)

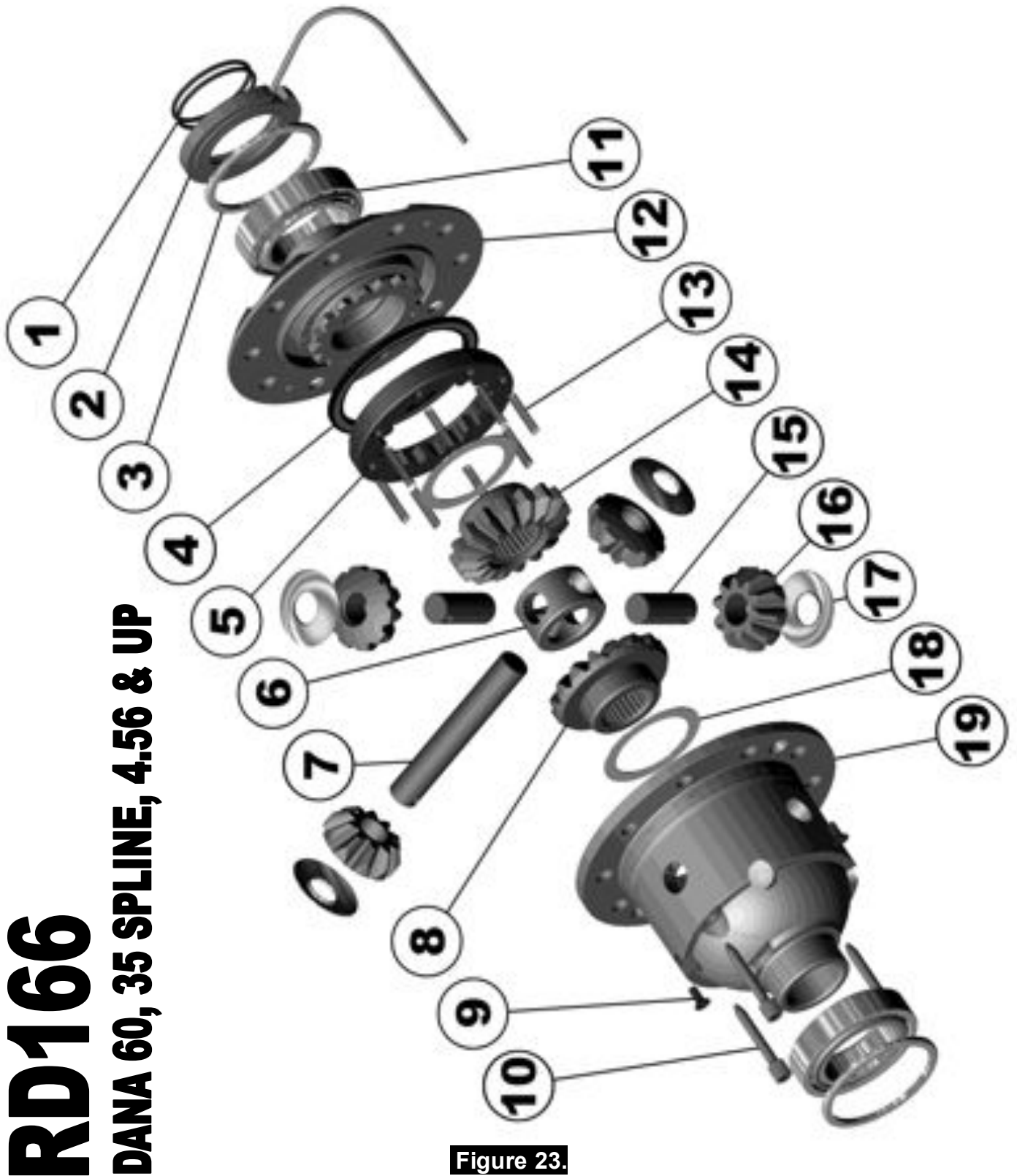

Figure 23.

7 Parts List

7.2 Itemized Parts List

(See exploded diagram figure 23.)

AIR LOCKER MODEL No. :		RD166	
ITEM #	QTY	DESCRIPTION	PART #
01	2	SEAL HOUSING O-RING	160248
02	1	SEAL HOUSING ASSEMBLY	082104
03	1	SHIM KIT	SHK001
*	1	MASTER SHIM	150330
*	1	MASTER SHIM	150331
04	1	BONDED SEAL	160703
05	1	CLUTCH GEAR	050807
06	1	SPIDER BLOCK	070402
07	1	LONG CROSS SHAFT	061501
08	1	SIDE GEAR	728K041**
09	2	COUNTERSUNK SCREW	200214
10	3	CROSS SHAFT RETAINING PIN	120601
11	2	TAPERED ROLLER BEARING	NOT SUPPLIED
12	1	FLANGE CAP ASSEMBLY	028605
13	12	RETURN SPRING	150107
14	1	SPLINED SIDE GEAR	728K041**
15	2	SHORT CROSS SHAFT	061601
16	4	PINION GEAR	728K041**
17	4	PINION THRUST WASHER	151113
18	2	SIDE GEAR THRUST WASHER	151007
19	1	DIFFERENTIAL CASE	013205
*	1	BULKHEAD KIT,O-RING TYPE,3.5-5mm	170111
*	1	PUSH-IN FITTING,5mm (R1 5 1/8")	170201
*	1	AIR LINE (5mm DIA X 6m LONG)	170301
*	1	NIPPLE, 1/8" BSP,MALE TO MALE	170501
*	1	SOLENOID VALVE	180103
*	1	ACTUATOR SWITCH	180209
*	1	SWITCH COVER (FRONT)	180210
*	1	SWITCH COVER (REAR)	180211
*	10	CABLE TIE	180301
*	1	WARNING LABEL	210101
*	1	BUMPER STICKER	210102
*	1	OPERATION & SERVICE MANUAL	210200
*	1	INSTALLATION GUIDE	2102166

* Not illustrated in exploded view.

** Available only as complete 6 gear set

