



# MICROWAVE OVEN

MR4381G

# *SERVICE* Manual

## MICROWAVE OVEN

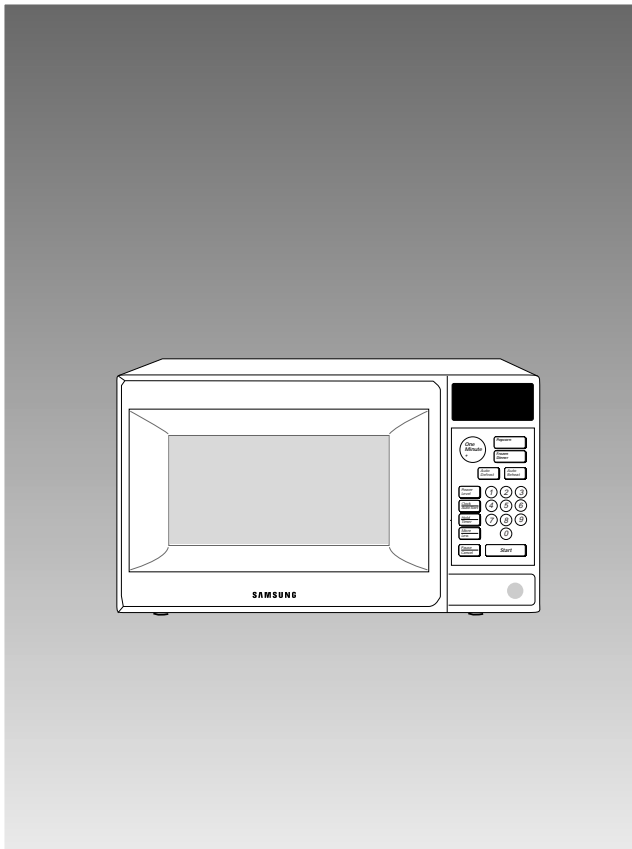

## CONTENTS

1. Precaution
2. Specifications
3. Operating Instructions
4. Disassembly and Reassembly
5. Alignment and Adjustments
6. Troubleshooting
7. Exploded Views and Parts List
8. PCB Diagrams
9. Schematic Diagrams

SEA

## **PRECAUTIONS TO BE OBSERVED BEFORE AND DURING SERVICING TO AVOID POSSIBLE EXPOSURE TO EXCESSIVE MICROWAVE ENERGY**

- (a) Do not operate or allow the oven to be operated with the door open.
- (b) Make the following safety checks on all ovens to be serviced before activating the magnetron or other microwave source, and make repairs as necessary:
  - (1) Interlock operation,
  - (2) proper door closing,
  - (3) seal and sealing surfaces (arcing, wear, and other damage),
  - (4) damage to or loosening of hinges and latches,
  - (5) evidence of dropping or abuse.
- (c) Before turning on microwave power for any service test or inspection within the microwave generating compartments, check the magnetron, wave guide or transmission line, and cavity for proper alignment, integrity, and connections.
- (d) Any defective or misadjusted components in the interlock, monitor, door seal, and microwave generation and transmission systems shall be repaired, replaced, or adjusted by procedures described in this manual before the oven is released to the owner.
- (e) A Microwave leakage check to verify compliance with the Federal performance standard should be performed on each oven prior to release to the owner.

---

# 1. Precaution

---

Follow these special safety precautions. Although the microwave oven is completely safe during ordinary use, repair work can be extremely hazardous due to possible exposure to microwave radiation, as well as potentially lethal high voltages and currents.

## 1-1 Safety precautions ( ⚠ )

---

1. All repairs should be done in accordance with the procedures described in this manual. This product complies with Federal Performance Standard 21 CFR Subchapter J (DHHS).
2. Microwave emission check should be performed to prior to servicing if the oven is operative.
3. If the oven operates with the door open : Instruct the user not to operate the oven and contact the manufacturer and the center for devices and radiological health immediatly.
4. Notify the Central Service Center if the microwave leakage exceeds 5 mW/cm<sup>2</sup>
5. Check all grounds.
6. Do not power the MWO from a "2-prong" AC cord. Be sure that all of the built-in protective devices are replaced. Restore any missing protective shields.
7. When reinstalling the chassis and its assemblies, be sure to restore all protective devices, including: nonmetallic control knobs and compartment covers.
8. Make sure that there are no cabinet openings through which people--particularly children--might insert objects and contact dangerous voltages. Examples: Lamp hole, ventilation slots.
9. Inform the manufacturer of any oven found to have emission in excess of 5 mW/cm<sup>2</sup>, Make repairs to bring the unit into compliance at no cost to owner and try to determine cause.  
Instruct owner not to use oven until it has been brought into compliance.  
  
**SAMSUNG ELECTRONICS AMERICA, INC.**  
**HEADQUARTER OFFICE**  
**105 CHALLENGER ROAD**  
**RIDGEFIELD PARK N.J.07660-0511**
10. Service technicians should remove their watches while repairing an MWO.
11. To avoid any possible radiation hazard, replace parts in accordance with the wiring diagram. Also, use only the exact replacements for the following parts: Primary and secondary interlock switches, interlock monitor switch.
12. If the fuse is blown by the Interlock Monitor Switch: Replace all of the following at the same time: Primary and secondary switches, as well as the Interlock Monitor Switch. The correct adjustment of these switches is described elsewhere in this manual. Make sure that the fuse has the correct rating for the particular model being repaired.
13. Design Alteration Warning:  
Use exact replacement parts only, i.e., only those that are specified in the drawings and parts lists of this manual. This is especially important for the Interlock switches, described above. Never alter or add to the mechanical or electrical design of the MWO. Any design changes or additions will void the manufacturer's warranty.10.Always unplug the unit's AC power cord from the AC power source before attempting to remove or reinstall any component or assembly.
14. Never defeat any of the B+ voltage interlocks. Do not apply AC power to the unit (or any of its assemblies) unless all solid-state heat sinks are correctly installed.
15. Some semiconductor ("solid state") devices are easily damaged by static electricity. Such components are called Electrostatically Sensitive Devices (ESDs). Examples include integrated circuits and field-effect transistors.  
  
Immediately before handling any semiconductor components or assemblies, drain the electrostatic charge from your body by touching a known earth ground.
16. Always connect a test instrument's ground lead to the instrument chassis ground *before* connecting the positive lead; always remove the instrument's ground lead last.

---

## 1-2 Special Servicing Precautions (Continued)

---

17. When checking the continuity of the witches or transformer, always make sure that the power is OFF, and one of the lead wires is disconnected.
18. Components that are critical for safety are indicated in the circuit diagram by shading, ▲ or ▲ .
19. Use replacement components that have the same ratings, especially for flame resistance and dielectric strength specifications. A replacement part that does not have the same safety characteristics as the original might create shock, fire or other hazards.

---

## 1-3 Special High Voltage Precautions

---

1. High Voltage Warning  
Do not attempt to measure any of the high voltages--this includes the filament voltage of the magnetron. High voltage is present during any cook cycle.  
  
Before touching any components or wiring, always unplug the oven and discharge the high voltage capacitor (See Figure 1-1)
2. The high-voltage capacitor remains charged about 30 seconds after disconnection. Short the negative terminal of the high-voltage capacitor to the oven chassis. (Use a screwdriver.)
3. High voltage is maintained within specified limits by close-tolerance, safety-related components and adjustments. If the high voltage exceeds the specified limits, check each of the special components.

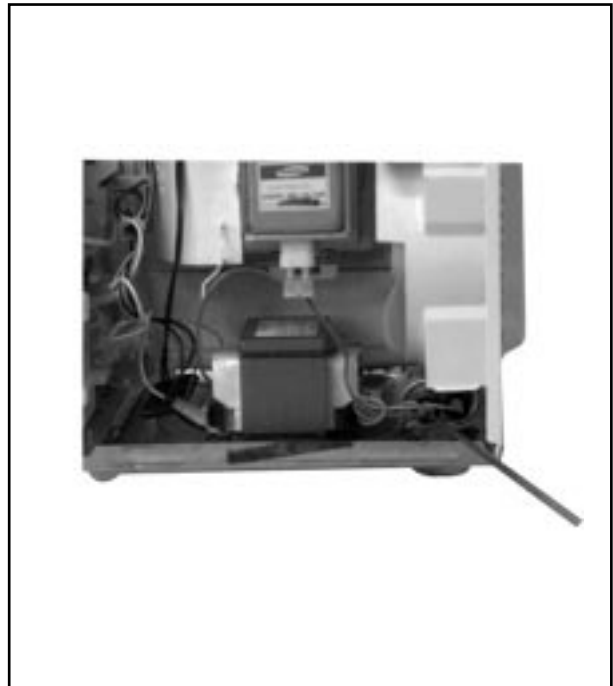

Fig. 1-1. Discharging the High Voltage Capacitor

## 2. Specifications

### 2-1 Table of Specifications

ITEM	MODEL	MR4381G
TIMER		99 MINUTES 99 SECONDS
POWER SOURCE		120V/60HZ, AC
POWER CONSUMPTION		MICROWAVE : 1,150W
OUTPUT POWER		FROM 70 TO 700W (10 LEVEL POWER) (IEC-705 TEST PROCEDURE)
OPERATING FREQUENCY		2,450MHz
MAGNETRON		OM75SH(31)
COOLING METHOD		COOLING FAN MOTOR
OUTSIDE DIMENSIONS		19 <sup>1</sup> / <sub>4</sub> "(W) x 11 <sup>5</sup> / <sub>8</sub> "(H) x 13 <sup>9</sup> / <sub>16</sub> "(D)
NET WEIGHT		30 LBS.
SHIPPING WEIGHT		33 LBS.

### 2-2 Comparison Chart

FEATURE	MODEL	MR4381G
MORE/LESS		○
AUTO REHEAT		○
AUTO DEFROST		○
TIME COOK		○
POWER LEVEL		○
INSTANT COOK		○
MEMORY		-
BOOST		-
CHILD LOCK		○
CLOCK		○
GRILL		-
COMBI		-

### 3. Operating Instructions

#### 3-1 Control Panel

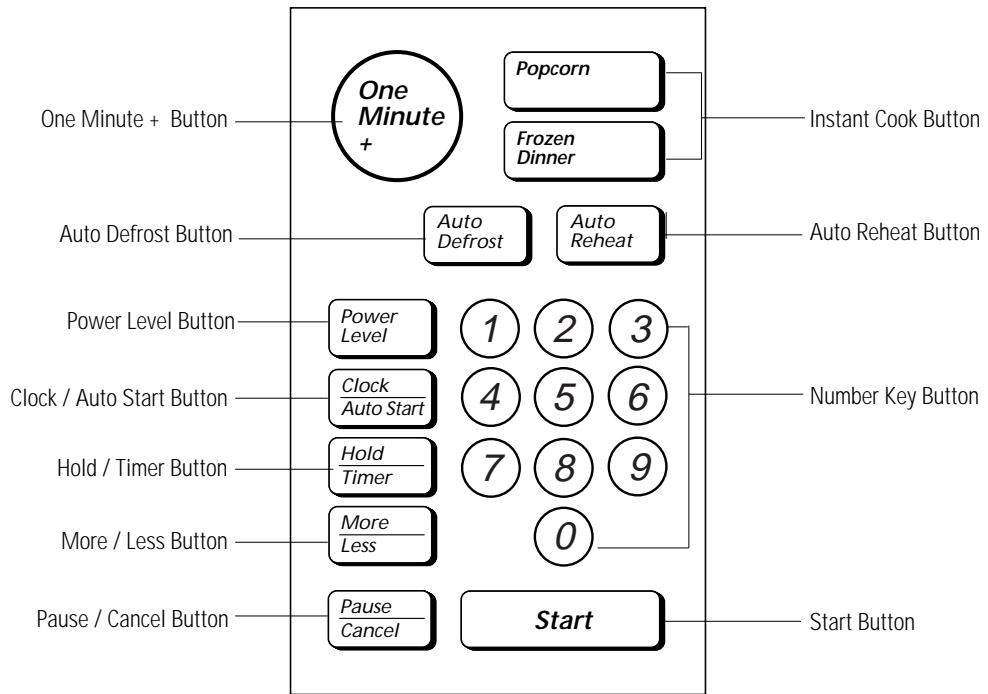

#### 3-2 Features & External Views

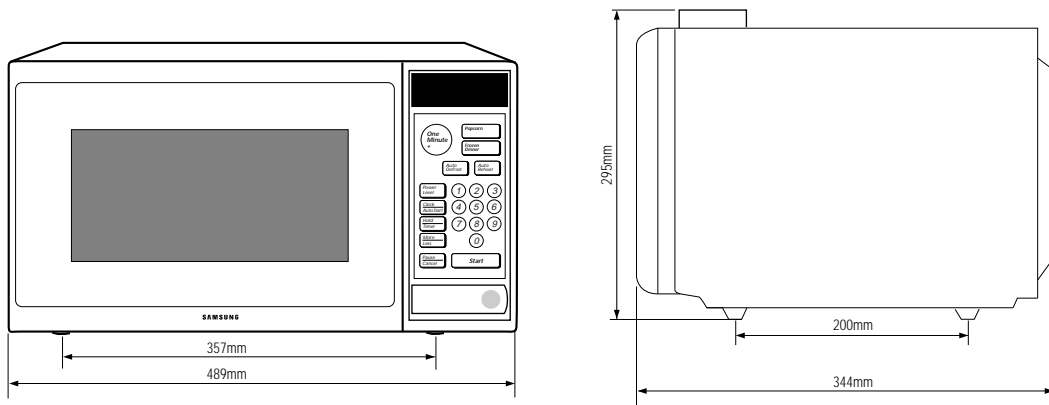
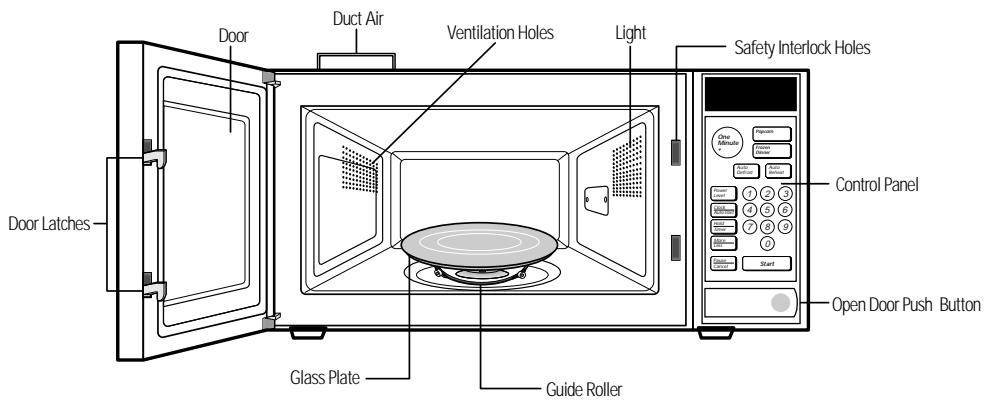

### 3-3 Installation Instructions

#### CAUTION

- **THIS OVEN WAS MANUFACTURED FOR USE IN A RECREATIONAL VEHICLE ONLY.**
- **MAY BE BUILT INTO A CABINET STRUCTURE, BUT NOT FOR USE ADJACENT TO (WITHIN 2 FEET OF) ANY GAS OR ELECTRIC RANGE, COOKTOP, OR OVEN**
- **PLUG THE THREE-PRONG POWER CORD INTO A PROPERLY GROUNDED OUTLET, 120V, 60Hz**

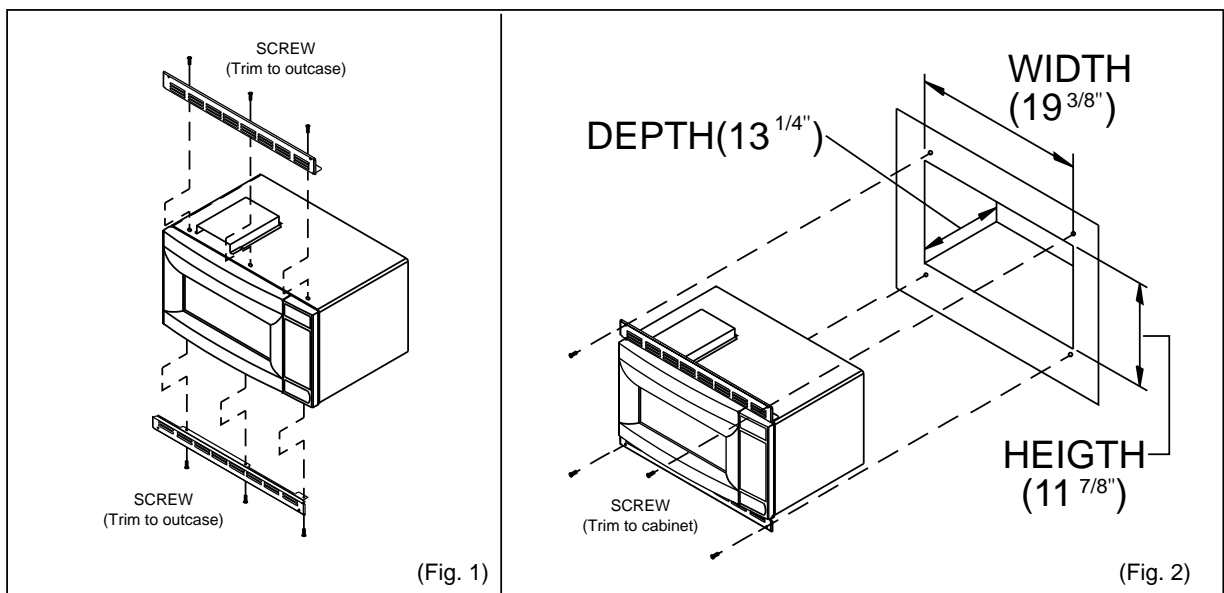

---

## 4. Disassembly and Reassembly

---

### 4-1 Replacement of Magnetron, Motor Assembly and Lamp

---

Remove the magnetron including the shield case, permanent magnet, choke coils and capacitors (all of which are contained in one assembly).

1. Disconnect all lead wires from the magnetron and lamp.
2. Remove the bracket mounting.
3. Remove the air cover.
4. Remove screws securing the magnetron to the wave guide.
5. Take out the magnetron very carefully.
6. Remove screws from the back panel.
7. Take out the fan motor.
8. Remove the oven lamp by pulling out from hole of air cover carefully.

NOTE1: When removing the magnetron, make sure that its antenna does not hit any adjacent parts, or it may be damaged.

NOTE2: When replacing the magnetron, be sure to remount the magnetron gasket in the correct position and make sure the gasket is in good condition.

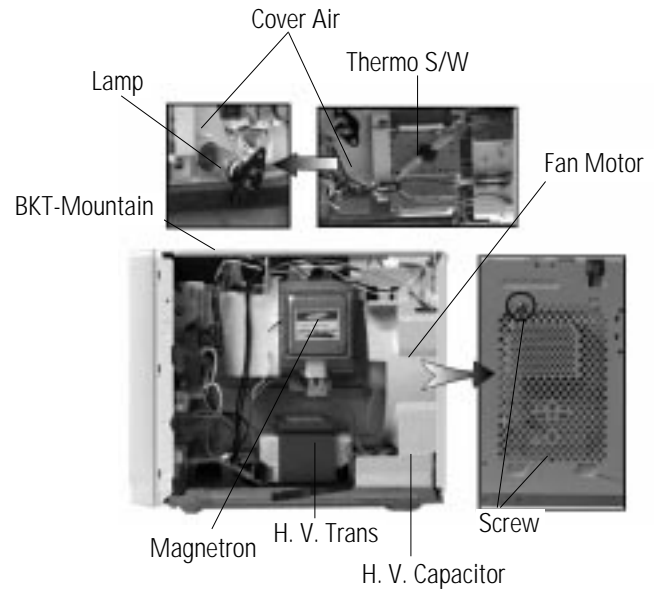

### 4-2 Replacement of High Voltage Transformer

---

1. Discharge the high voltage capacitor.
2. Disconnect all the leads.
3. Remove the mounting bolts.
4. Reconnect the leads correctly and firmly.

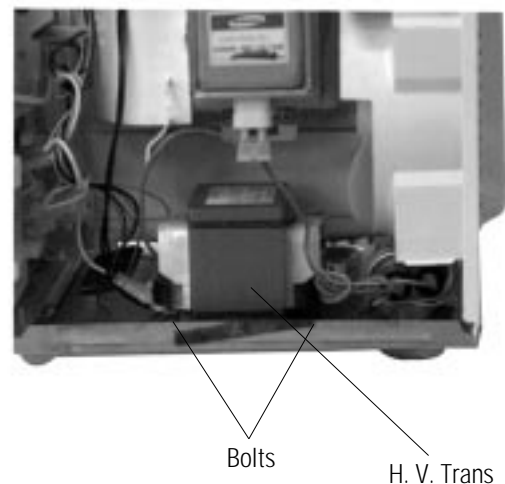



## 4-3 Replacement of Door Assembly

### 4-3-1 Removal of Door Assembly

Remove screws securing the upper hinge and lower hinge. Then remove the door assembly.

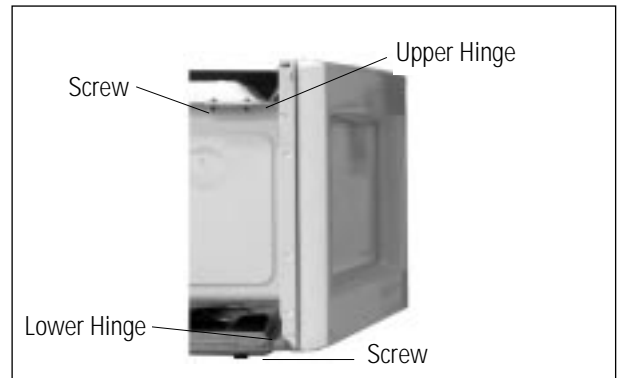

### 4-3-2 Removal of Door "C"

Insert flat screwdriver into the gap between Door "A" and Door "C" to remove Door "C". Be careful when handling Door "C" because it is fragile.

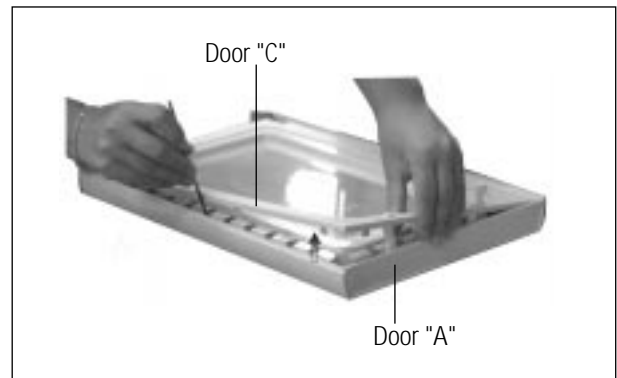

### 4-3-3 Removal of Door "E"

Following the procedure as shown in the figure, insert and bend a thin metal plate between Door "E" and Door "A" until you hear the 'tick' sound.

1. Insertion depth of the thin metal plate should be 0.5mm or less.

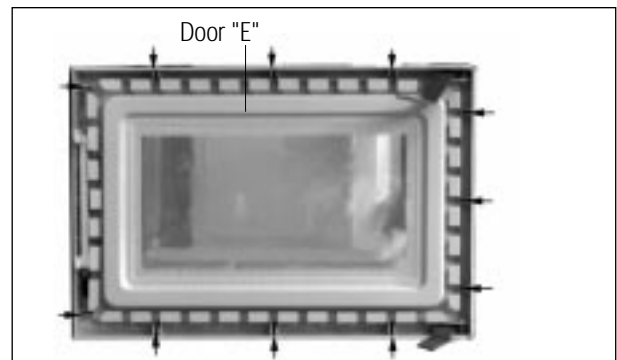

### 4-3-4 Removal of Key Door & Spring

Remove pin hinge from Door "E"  
Detach spring from Door "E" and key door.

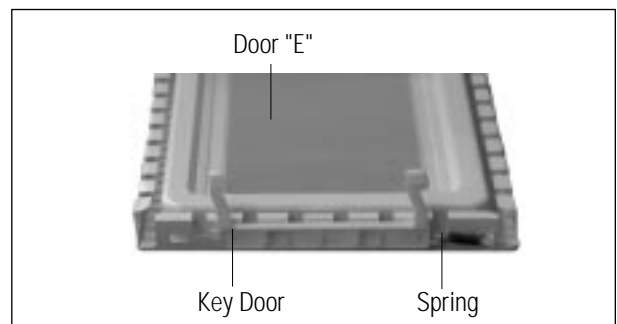

### 4-3-5 Reassembly Test

After replacement of the defective component parts of the door, reassemble it and follow the instructions below for proper installation and adjustment so as to prevent an excessive microwave leakage.

1. When mounting the door to the oven, be sure to adjust the door parallel to the bottom line of the oven face plate by moving the upper hinge and lower hinge in the direction necessary for proper alignment.
2. Adjust so that the door has no play between the inner door surface and oven front surface. If the door assembly is not mounted properly, microwave energy may leak from the space between the door and oven.
3. Do the microwave leakage test.

### 4-4 Replacement of Fuse

1. Disconnect the oven from the power source.
2. Remove the 15A fuse in the fuse holder.
3. When replacing the 15A fuse, be sure to use an exact replacement part. If new 15A fuse blows out again after replacement, check the primary interlock switch, door sensing switch and interlock monitor switch.
4. When the above three switches operate properly, check if any other part such as the control circuit board, blower motor or high voltage transformer is defective.

### 4-5 Replacement of Drive Motor

1. Take out the glass tray and guide roller from the cavity.
2. Turn the oven upside down to replace the drive motor.
3. Remove a screw securing the drive motor cover.
4. Disconnect all the lead wires from the drive motor.
5. Remove screws securing the drive motor to the cavity.
6. Remove the drive motor and coupler.
7. When replacing the drive motor, be sure to remount it in the correct position with the coupler.
8. Connect all the leads to the drive motor.
9. Screw the drive motor cover to the base plate with a screw driver.

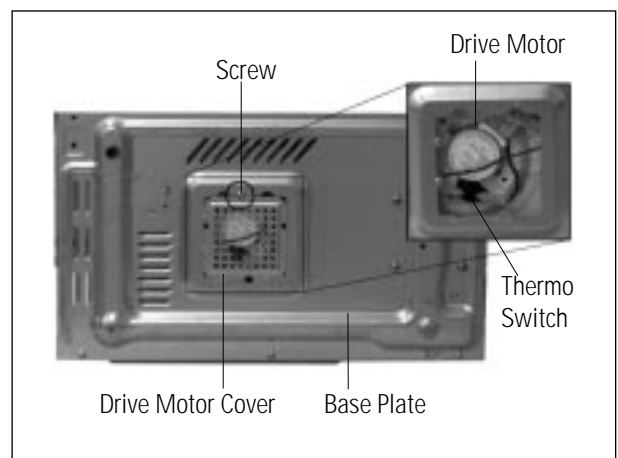

## 4-6 Replacement of Control Circuit Board

### 4-6-1 Removal of Control Box Assembly

1. Be sure to ground any static electric charge in your body and never touch the control circuit.
2. Disconnect the connectors from the control circuit board.
3. Remove screws securing the control box assembly.
4. Remove the screw securing the ground tail of the keyboard.

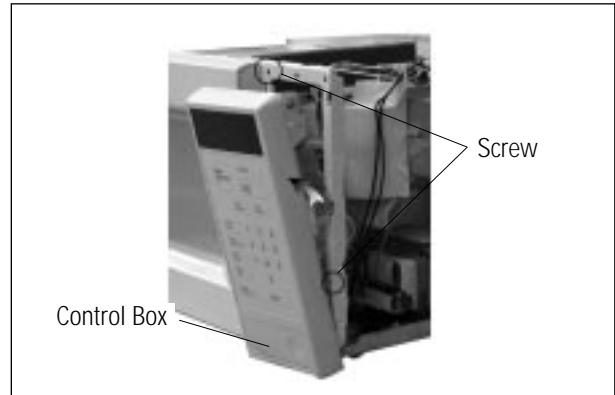

### 4-6-2 Removal of P.C.B Assembly

1. Pull the lever end of the plastic fastener and remove the Flexible Printed Circuit(FPC) of membrane panel.
2. Remove screws securing the control circuit board.
3. Lift up the control circuit board from the Ass'y control box.
4. When reconnecting the FPC connector, make sure that the holes on the connector are properly engaged with the hooks on the Plastic Fastener.

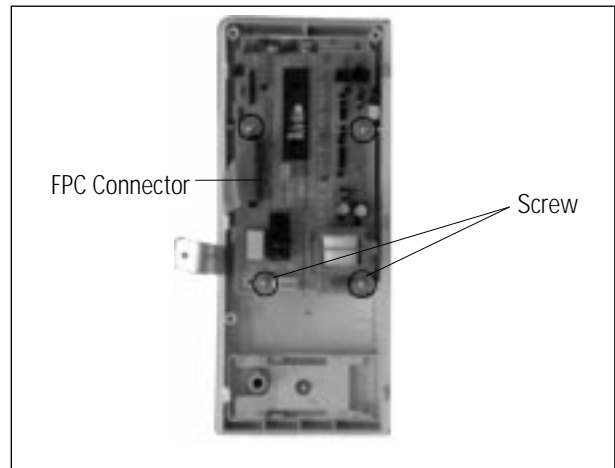

### 4-6-3 Removal of Window Display & Membrane Panel

1. Window display should not be disassembled as its mounting tabs will be broken. If repair work is difficult, replace with Ass'y control panel.
2. The membrane key board is attached to the escutcheon base with doublefaced adhesive tape. Therefore, applying hot air such as using of hair dryer is recommended for smoother removal.
3. When installing new membrane key board, make sure that the surface of escutcheon base is cleaned sufficiently so that any problems (shorted contacts or uneven surface) can be avoided.



## 5. Alignment and Adjustments

### PRECAUTION

1. High voltage is present at the high voltage terminals during any cook cycle.
2. It is neither necessary nor advisable to attempt measurement of the high voltage.
3. Before touching any oven components or wiring, always unplug the oven from its power source and discharge the high voltage capacitor.

### 5-1 High Voltage Transformer

1. Remove connectors from the transformer terminals and check continuity.
2. Normal resistance readings are as follows:

MODEL	SHV-4370UCI
Secondary	123.5Ω ±10%
Filament	Shows Continuity
Primary	0.557Ω ± 10%

(Room temperature = 20°C)

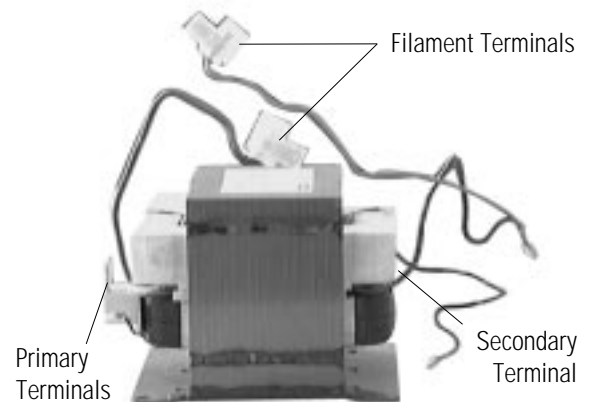

### 5-2 Low Voltage Transformer

1. The low voltage transformer is located on the control circuit board.
2. Remove the low voltage transformer from the PCB Ass'y and check continuity.
3. Normal resistor reading is shown in the table.

Terminals	Resistance
	CE-5574W
1-2(Input)	248.7Ω
4-5(Output17V)	9.55Ω
7-8(Output2.7V)	1.63Ω

### 5-3 Magnetron

1. Continuity checks can indicate only an open filament or a shorted magnetron. To diagnose an open filament or shorted magnetron :
2. Isolate the magnetron from the circuit by disconnecting its leads.
3. A continuity check across the magnetron filament terminals should indicate one ohm or less.
4. A continuity check between each filament terminal and magnetron case should read open.

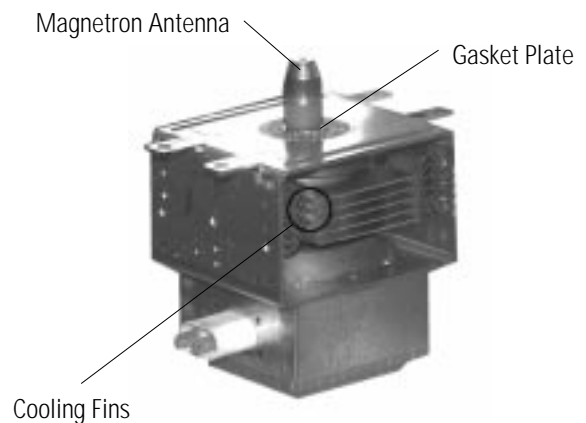

## 5-4 High Voltage Capacitor

1. Check continuity of the capacitor with the meter set at the highest resistance scale.
2. Once the capacitor is charged, a normal capacitor shows continuity for a short time, and then indicates 9MΩ.
3. A shorted capacitor will show continuous continuity.
4. An open capacitor will show constant 9MΩ.
5. Resistance between each terminal and chassis should read infinite.

## 5-5 High Voltage Diode

1. Isolate the diode from the circuit by disconnecting its leads.
2. With the ohm-meter set at the highest resistance scale, measure across the diode terminals. Reverse the meter leads and read the resistance. A meter with 6V, 9V or higher voltage batteries should be used to check the front-to back resistance of the diode (otherwise an infinite resistance may be read in both directions). The resistance of a normal diode will be infinite in one direction and several hundred KΩ in the other direction.

## 5-6 Main Relay and Power Control Relay

1. The relays are located on the PCB Ass'y. Isolate them from the main circuit by disconnecting the leads.
2. Operate the microwave oven with a water load in the oven. Set the power level set to high.
3. Check continuity between terminals of the relays after the start pad is pressed.

## 5-7 Adjustment of Primary Switch, Door Sensing Switch and Monitor Switch

### Precaution

For continued protection against radiation hazard, replace parts in accordance with the wiring diagram and be sure to use the correct part number for the following switches: Primary interlock and secondary interlock(door sensing), and the interlock monitor switch (replace all together). Then follow the adjustment procedures below. After repair and adjustment, be sure to check the continuity of all interlock switches and the interlock monitor switch.

1. When mounting Primary switch, Interlock Monitor switch and Secondary switch to Latch Body, consult the figure.
2. No specific adjustment during installation of Primary switch and Monitor switch to the latch body is necessary.
3. When mounting the Latch Body to the oven assembly, adjust the Latch Body by moving it so that the oven door will not have any play in it. Check for play in the door by pulling the door assembly. Make sure that the latch keys move smoothly after adjustment is completed. Completely tighten the screws holding the Latch Body to the oven assembly.
4. Reconnect to Monitor switch and check the continuity of the monitor circuit and all latch switches again by following the components test procedures.
5. Confirm that the gap between the switch housing and the switch actuator is no more than 0.5mm when door is closed.

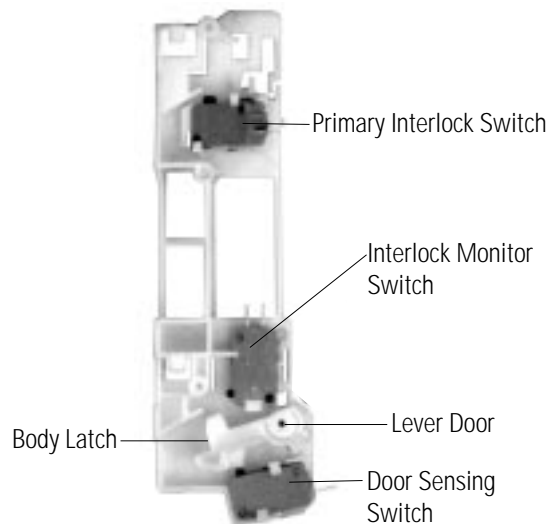

	Door Open	Door Closed
Primary switch	∞	0
Monitor switch (COM-NC)	0	∞
Door Sensing S/W	∞	0

## 5-8 Output Power of Magnetron

### CAUTION MICROWAVE RADIATION

PERSONNEL SHOULD NOT ALLOW EXPOSURE TO MICROWAVE RADIATION FROM MICROWAVE GENERATOR OR OTHER PARTS CONDUCTING MICROWAVE ENERGY.

The output power of the magnetron can be measured by performing a water temperature rise test.

Equipment needed :

\* Two 1-liter cylindrical borosilicate glass vessel (Outside diameter 190 mm)

\* One glass thermometer with mercury column

NOTE: Check line voltage under load. Low voltage will lower the magnetron output. Make all temperature and time tests with accurate equipment.

1. Fill the one liter glass vessel with water.
2. Stir water in glass vessel with thermometer, and record glass vessel's temperature ("T1", 10±1°C).
3. After moving the water into another glass vessel, place it in the center of the cooking tray. Set the oven to high power and operate for 61seconds exactly. (2 seconds included as a holding time of magnetron oscillation:)
4. When heating is finished, stir the water again with the thermometer and measure the temperature ("T2").
5. Subtract T1 from T2. This will give you the water temperature rise. (ΔT)
6. The output power is obtained by the following formula;

$$\text{Output Power} = \frac{4.187 \times 1000 \times \Delta T + 0.88 \times Mc \times (T_2 - T_0)}{59.81}$$

59.81: Heating Time (sec)  
4.187 : Coefficient for Water  
1000 : Water (cc)  
ΔT : Temperature Rise (T2-T1)  
Mc : Cylindrical borosilicate glass weight  
T<sub>0</sub> : Room temperature.

7. Normal temperature rise for this model is 9°C to 11°C at 'HIGH'.

NOTE 1: Variations or errors in the test procedure will cause a variance in the temperature rise.

Additional power test should be made if temperature rise is marginal.

NOTE 2: Output power in watts is computed by multiplying the temperature rise (step 5) by a factor of 70 times the of centigrade temperature.

## 5-10 Microwave Heat Distribution - Heat Evenness

The microwave heat distribution can be checked indirectly by measuring the water temperature rise at certain positions in the oven:

1. Prepare five beakers made of 'Pyrex', having 100 milliliters capacity each.
2. Measure exactly 100milliliters off water load with a measuring cylinder, and pour into each beaker.
3. Measure the temperature of each water load. (Readings shall be taken to the first place of decimals.)
4. Put each beaker in place on the cooking tray as illustrated in figure below. Start heating.
5. After heating for 2 minutes, measure the water temperature in each beaker.
6. Microwave heat distribution rate can be calculated as follows:

$$\text{Heat Distribution} = \frac{\text{Minimum Temperature Rise}}{\text{Maximum Temperature Rise}} \times 100(\%)$$

The result should exceed 65%.

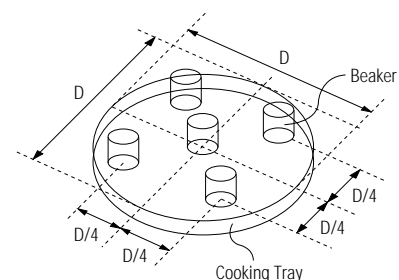

## 5-10 Procedure for Measurement of Microwave Energy Leakage

- 1) Pour  $275 \pm 15$ cc of  $20 \pm 5^\circ\text{C}$  ( $68 \pm 9^\circ\text{F}$ ) water in a beaker which is graduated to 600cc, and place the beaker in the center of the oven.
- 2) Start to operate the oven and measure the leakage by using a microwave energy survey meter.
- 3) Set survey meter with dual ranges to 2,450MHz.
- 4) When measuring the leakage, always use the 2 inch spacer cone with the probe. Hold the probe perpendicular to the cabinet door. Place the spacer cone of the probe on the door and/or cabinet door seam and move along the seam, the door viewing window and the exhaust openings moving the probe in a clockwise direction at a rate of 1 inch/sec. If the leakage testing of the cabinet door seam is taken near a corner of the door, keep the probe perpendicular to the areas making sure that the probe end at the base of the cone does not get closer than 2 inches to any metal. If it gets closer than 2 inches, erroneous readings may result.
- 5) Measured leakage must be less than  $4\text{mW}/\text{cm}^2$ , after repair or adjustment.

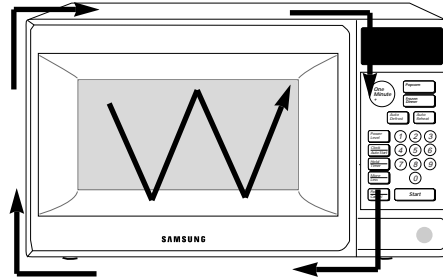

Maximum allowable leakage is  $5\text{mW}/\text{cm}^2$ .  
 $4\text{mW}/\text{cm}^2$  is used to allow for measurement and meter accuracy

## 5-11 Check for Microwave Leakage

1. Remove the outer panel.
2. Pour  $275 \pm 15$ cc of  $20 \pm 5^\circ\text{C}$  ( $68 \pm 9^\circ\text{F}$ ) water in a beaker which is graduated to 600cc, and place the beaker in the center of the oven.
3. Start the oven at the highest power level.
4. Set survey meter dual ranges to 2,450MHz.
5. Using the survey meter and spacer cone as described above, measure the opening of magnetron, the surface of the air guide and the surface of the wave guide as shown in the following photo.( but avoid the high voltage components.) The reading should be less than  $4\text{mW}/\text{cm}^2$ .



## 5-12. Note on Measurement

- 1) Do not exceed the limited scale.
- 2) The test probe must be held on the grip of the handle, otherwise a false reading may result when the operator's hand is between the handle and the probe.
- 3) When high leakage is suspected, do not move the probe horizontally along the oven surface; this may cause damage to the probe.
- 4) Follow the recommendation of the manufacturer of the microwave energy survey meter.

## 5-13 Leakage Measuring Procedure

### 5-13-1 Record keeping and notification after measurement

- 1) After adjustment and repair of a radiation preventing device, make a repair record for the measured values, and keep the data.
- 2) If the radiation leakage is more than  $5\text{mW}/\text{cm}^2$  after determining that all parts are in good condition, functioning properly and the identical parts are replaced as listed in this manual notify that fact to ;

**Samsung Electronics America, inc.**  
**Headquarter office**  
**105 challenger road**  
**ridgefield park n.j.07660-0511**

### 5-13-2 At least once a year have the microwave energy survey meter checked for accuracy by its manufacturer.

## 6. Troubleshooting

### PRECAUTION

1. CHECK GROUNDING BEFORE CHECKING FOR TROUBLE.
2. BE CAREFUL OF THE HIGH VOLTAGE CIRCUIT.
3. DISCHARGE THE HIGH VOLTAGE CAPACITOR.
4. WHEN CHECKING THE CONTINUITY OF THE SWITCHES OR TRANSFORMER, DISCONNECT ONE LEAD WIRE FROM THESE PARTS AND THEN CHECK CONTINUITY WITHOUT THE POWER SOURCE ON. TO DO OTHERWISE MAY RESULT IN A FALSE READING OR DAMAGE TO YOUR METER.
5. DO NOT TOUCH ANY PART OF THE CIRCUIT OR THE CONTROL CIRCUIT BOARD, SINCE STATIC DISCHARGE MAY DAMAGE IT. ALWAYS TOUCH GROUND WHILE WORKING ON IT TO DISCHARGE ANY STATIC CHARGE BUILT UP.

### 6-1 Electrical Malfunction

SYMPTOM	CAUSE	CORRECTIONS
Oven is dead. Fuse is OK. No display and no operation at all.	<ol style="list-style-type: none"> <li>1. Open or loose lead wire harness</li> <li>2. Open thermal cutout (Magnetron)</li> <li>3. Open low voltage transformer</li> <li>4. Defective Ass'y PCB</li> </ol>	<p>Check fan motor when thermal cutout is defective.</p> <p>Check Ass'y PCB when LVT is defective.</p>
No display and no operation at all. Fuse is blown.	<ol style="list-style-type: none"> <li>1. Shorted lead wire harness</li> <li>2. Defective primary latch switch (NOTE 1)</li> <li>3. Defective monitor switch (NOTE1)</li> <li>4. Shorted HVCapacitor</li> <li>5. Shorted HVTransformer (NOTE2)</li> </ol> <p>NOTE 1: All of these switches must be replaced at the same time. (refer to adjustment instructions) Check continuity of power relay contacts and if it has continuity, replace power relay also.</p> <p>NOTE 2: When HVTransformer is replaced, check diode and magnetron also.</p>	<p>Check adjustment of primary, interlock monitor, door sensing switch.</p>
Oven does not accept key input (Program)	<ol style="list-style-type: none"> <li>1. Key input is not in-Sequence</li> <li>2. Open or loose connection of membrane key pad to Ass'y PCB</li> <li>3. Shorted or open membrane panel</li> <li>4. Defective Ass'y PCB</li> </ol>	<p>Refer to operation procedure.</p> <p>Replace PCB main.</p>
Timer starts countdown but no microwave oscillation. (No heat while oven lamp and fan motor turn on.)	<ol style="list-style-type: none"> <li>1. Off-alignment of latch switches</li> <li>2. Open or loose connection of high voltage circuit especially magnetron filament circuit</li> </ol> <p>NOTE: Large contact resistance will bring lower magnetron filament voltage and cause magnetron to lower output and/or intermittent oscillation.</p> <ol style="list-style-type: none"> <li>3. Defective high voltage components H.V.Transformer H.V.Capacitor H.V.Diode Magnetron</li> <li>4. Open or loose wiring of power relay</li> <li>5. Defective primary latch switch</li> <li>6. Defective power relay or Ass'y PCB</li> </ol>	<p>Adjust door and latch switches.</p> <p>Check high voltage component according to component test procedure and replace if it is defective.</p> <p>Replace PCB main.</p>



## 6-1 Electrical Malfunction(continued)

SYMPTOM	CAUSE	CORRECTIONS
Oven lamp and fan motor turn on	<ol style="list-style-type: none"> <li>Misadjustment or loose wiring of primary latch switch</li> <li>Defective primary latch switch</li> </ol>	Adjust door and latch switches.
Oven can program but timer does not start.	<ol style="list-style-type: none"> <li>Open or loose wiring of secondary interlock switch</li> <li>Off-alignment of primary interlock</li> <li>Defective secondary interlock S/W</li> </ol>	Adjust door and interlock switches.
Microwave output is low;. Oven takes longer time to cook food.	<ol style="list-style-type: none"> <li>Decrease in power source voltage.</li> <li>Open or loose wiring of magnetron filament circuit. (Intermittent oscillation))</li> <li>Aging of magnetron</li> </ol>	Consult electrician.
Fan motor turns on when plugged in	Loose wiring of door sensing switch	Check wire of door sensing switch.
Oven does not operate and return to the plugged in mode.	Defective Ass'y PCB	Replace PCB main.
Loud buzzing noise can be heard.	<ol style="list-style-type: none"> <li>Loose fan and fan motor</li> <li>Loose screws on H.V. Transformer</li> <li>Shorted H.V.Diode</li> </ol>	Tighten screws of fan motor. Tighten screws of H.V. Transformer. Replace H.V.Diode.
Turntable motor does not rotate.	<ol style="list-style-type: none"> <li>Open or loose wiring of turntable motor.</li> <li>Defective turntable motor.</li> </ol>	Check the wire of turntable motor Replace turntable motor.
Oven stops operation during cooking	<ol style="list-style-type: none"> <li>Open or loose wiring of primary interlock switch</li> <li>Operation of thermal cutout(Magnetron)</li> </ol>	Adjust door and latch switches.
Sparks	<ol style="list-style-type: none"> <li>Metallic ware or cooking dishes touching on the oven wall.</li> <li>Ceramic ware trimmed with gold or silver powder also causes sparks.</li> </ol>	Inform the customer.  Do not use any type of cookware with metallic trimming.
Uneven cooking	Uneven intensity of microwave due to its characteristics.	Wrap thinner parts of the food with aluminum foil. Use plastic wrap or cover with a lid. Stir once or twice while cooking foods such as soup, cocoa, or milk.
Noise from the turntable motor when it starts to operate.	Noise may result from the motor.	Replace turntable motor.

# 7. Exploded Views and Parts List

## 7-1 Exploded Views

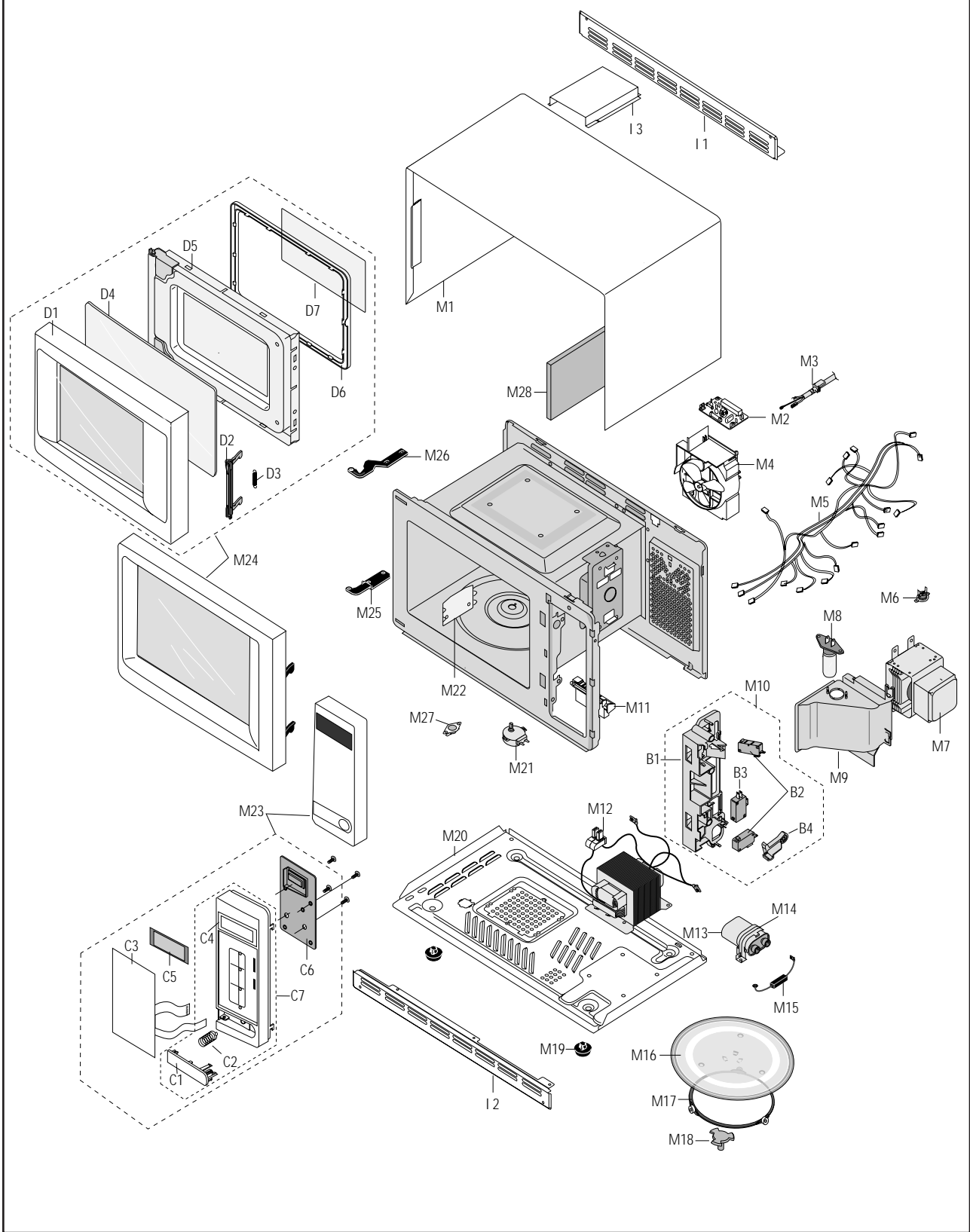

## 7-2 Main Parts List

Ref. No.	Parts No.	Description/Specification	Q'ty	Remarks
M 1	DE70-30128A	PANEL-OUTER;SECC T0.6 W351.7 L1014.7 MTR	1	
M 2	DE91-40100A	ASSY NOISE FILTER;SN-U15A 250V 15A SECA	1	
M 3	DE39-20037E	ASSY POWER CORD;SJT AWG16 GRY 230V50HZ L135	1	●
M 4	DE31-30031B	FAN-MOTOR;SMF437UA 120V/60HZ ASSY-FAN-MO	1	●
M 5	DE39-40699A	WIRE HARNESS-A;120V60HZ MR4381G R/V MODEL	1	●
M 6	DE47-20009A	THERMOSTAT;CS-7SA(160/60) 187Y 250V7.5A 160	1	●
M 7	DE03-30029A	MAGNETRON;OM75SH(31)ESS	1	▲
M 8	4713-001012	LAMP-INCANDESCENT;130V,-,40W,ORG,B/L,-,2	1	●
M 9	DE71-60010A	COVER-AIR;PP(TB53) T1.7 WHT 64G M745	1	●
M 10	DE93-20001D	ASSY BODY LATCH;2ND-SEA MW4370W	1	●
M 11	DE66-90013A	LEVER-DOOR;POM(F20-01) NTR MW5630T	1	
M 12	DE26-10113A	TRANS-H.V;SHV-4370UC1 120V 60HZ DPC 2080V	1	● ▲
M 13	2501-001018	C-OIL;800nF,2100V,35X54X70,20mm,BK	1	●
M 14	DE61-50106A	BRACKET-HVC;SECC T0.8 W31 L125.8	1	
M 15	DE59-40001A	DIODE-H.V;HVR-1X-32B-12	1	
M 16	DE74-20102B	TRAY-COOKING;GLASS T5.0 PI288 780G M745	1	●
M 17	DE92-90436A	ASSY-GUIDE ROLLER;MW4370W	1	●
M 18	DE67-60002A	COUPLER;PPS 5GR BRN M97G45	1	●
M 19	DE61-40017A	FOOT;PP(A353) BLK MW5630T	2	
M 20	DE80-10117A	BASE-PLATE;SGCC1-Z T0.8 W340 L550 MTR43	1	●
M 21	DE31-10154A	MOTOR-DRIVE;M2HJ49ZR02,ST-16 21V 5/6	1	●
M 22	DE71-60011A	COVER-MGT;PP T2.0 WHT M745	1	●
M 23		ASSY CONTROL-BOX;120V60HZ MR4371G GRY	1	● ▲
M 24		ASSY DOOR;PUSH D-GRAY MW4371G	1	● ▲
M 25	DE61-80004A	HINGE-LOWER;SCP1 T2.3 ZN-COATING BLK	1	●
M 26	DE61-80005A	HINGE-UPPER;SCP1 T2.3 BLK ZN-COATING	1	●
M 27	DE47-20008A	THERMOSTAT;PW2N-52JC 100/60 250V/7.5A H	1	●
M 28	DE63-90035G	CUSHION-RUBBER;DFA20 T2 W190 L100 BLK	1	
M 29	DE72-50094A	DUCT-AIR;SGCC1-Z T0.6 MR4381G(2ND	1	

● : Option Parts

▲ : Warning

▲ :Electrostatically Sensitive Devices

### 7-3 Door Parts List

Ref. No.	Parts No.	Description/Specification	Q'ty	Remarks
D 1	DE64-40014B	DOOR-A;ABS (HR0370) T3 MW4371G	1	●
D 2	DE64-40006A	DOOR-KEY;POM(TC3005) T2.0 12GR BLK CE945G	1	●
D 3	DE61-70033A	SPRING-KEY;ES HSWR10 PI0.6 D6.0 L22.3 BL	1	
D 4	DE67-20151E	SCREEN-DOOR;PET T1.1888 W166 L305 NO-BEDA	1	● ▲
D 5	DE92-50126B	ASSY DOOR-E;COATING BLK CE745G	1	●
D 6	DE64-40008B	DOOR-C;PP T1.5 BLK CE745G	1	●
D 7	DE01-00003A	FILM-DOOR;PE-FILM T0.15 W143 L265 M745	1	●

### 7-4 Control Parts List

Ref. No.	Parts No.	Description/Specification	Q'ty	Remarks
C 1	DE66-20010B	BUTTON-PUSH;ABS D-GRY ME4371G	1	●
C 2	DE61-70076A	SPRING-BUTTON;HSWR PI0.6	1	
C 3	DE34-10202T	SWITCH-MEMBRANE;PET MR4381G/XAA SEA	1	● ▲
C 4	DE72-70009B	CONTROL-PANEL;ABS (VH-0853) 173.5G GRY MW437	1	●
C 5	DE67-40003A	WINDOW-DISPLAY;ACRYL T2.3 W36.8 L91.8 SM	1	●
C 6	DE91-10368A	ASSY P.C.B-MAIN;120V/60HZ NS V.F.D N/HEL	1	● ▲
C 7	DE93-30384B	ASSY CONTROL-PANEL;N-DESIGN D/GRY MW4371G	1	

### 7-5 Body Latch Parts List

Ref. No.	Parts No.	Description/Specification	Q'ty	Remarks
B 1	DE66-40001A	LATCH-BODY;POM(F20-02) 40GR NTR	1	
B 2	3405-000178	SWITCH-MICRO;250V,15A,200gf,SPST-NO	3	
B 3	3405-000175	SWITCH-MICRO;250V,15A,200gf,SPST-NO	1	
B 4	DE66-90001A	LEVER-SWITCH;P.O.M(F20-02) 2 6 NTR 2ND-W	1	

### 7-6 Installation Parts List

Ref. No.	Parts No.	Description/Specification	Q'ty	Remarks
I 1	DE64-90157A	TRIMMER-UPPER;SECC T0.8 W150 L90 MTR43	1	
I 2	DE64-90158A	TRIMMER-LOWER;SECC T0.8 W150 L80 BLK MTR	1	
I 3	DE72-50094A	DUCT-AIR;SGCC1-Z T0.6 MR4381G(2NG	1	

## 7-7 Standard Parts List

Parts No.	Description / Specification	Q'ty	Remarks
DE60-10066A	SCREW-TAP TH;TH M4 L8 FEFZY 2-SLOT	1	MEM-PN
DE60-10069A	SCREW-TAP TH;TH M4 L10 FRFZY	4	B-PLTE
DE60-10069A	SCREW-TAP TH;TH M4 L10 FRFZY	1	CV/AIR
DE60-10080A	SCREW-WASHER;M5 L12 2S	4	HVT
DE60-10080A	SCREW-WASHER;M5 L12 2S	4	MGT
DE60-10053A	SCREW-TAP PH;PH M4 L10 FEFZY	1	CV-TCO
DE02-00029A	TAPE-SCOTCHPAR;POLYESTER 3M-893 W50	1	
DE60-10082H	SCREW-A;2S-4X12 TOOTHED	2	BD-LAT
DE60-10082H	SCREW-A;2S-4X12 TOOTHED	2	CON-BX
DE60-10082H	SCREW-A;2S-4X12 TOOTHED	4	OUT-PN
DE60-10045A	SCREW-TAP PH;PH M3 L6 FEFZY	2	MGT-TC
DE60-10053A	SCREW-TAP PH;PH M4 L10 FEFZY	1	FUSE-H
DE60-10053A	SCREW-TAP PH;PH M4 L10 FEFZY	2	M/GEAR
DE60-10066A	SCREW-TAP TH;TH M4 L8 FEFZY 2-SLOT	1	B/HVC
DE60-10082H	SCREW-A;2S-4X12 TOOTHED	1	P-CO-E
DE60-10082H	SCREW-A;2S-4X12 TOOTHED	2	CV/BLW
DE60-10082H	SCREW-A;2S-4X12 TOOTHED	1	B/DR-M
DE60-10088A	SCREW-TAP PH;PH M3 L8 FEFZY PLAIN	2	P.C.B
DE60-10082A	SCREW-A;M4 L12 2S TOOTHED	4	OUT-PN
DE60-10082A	SCREW-A;M4 L12 2S TOOTHED	1	B/DR-M
DE60-10082A	SCREW-A;M4 L12 2S TOOTHED	2	CON-PA
DE60-10012A	SCREW-TAP TITE;TH + 3 M4 L10 SWR10 ZPC2	2	HI-UPP
DE60-10082A	SCREW-A;M4 L12 2S TOOTHED	1	P-CO-E
DE60-10012A	SCREW-TAP TITE;TH + 3 M4 L10 SWR10 ZPC2	2	HI-LOW

# 8. P.C.B Diagrams

## 8-1 P.C.B Diagrams

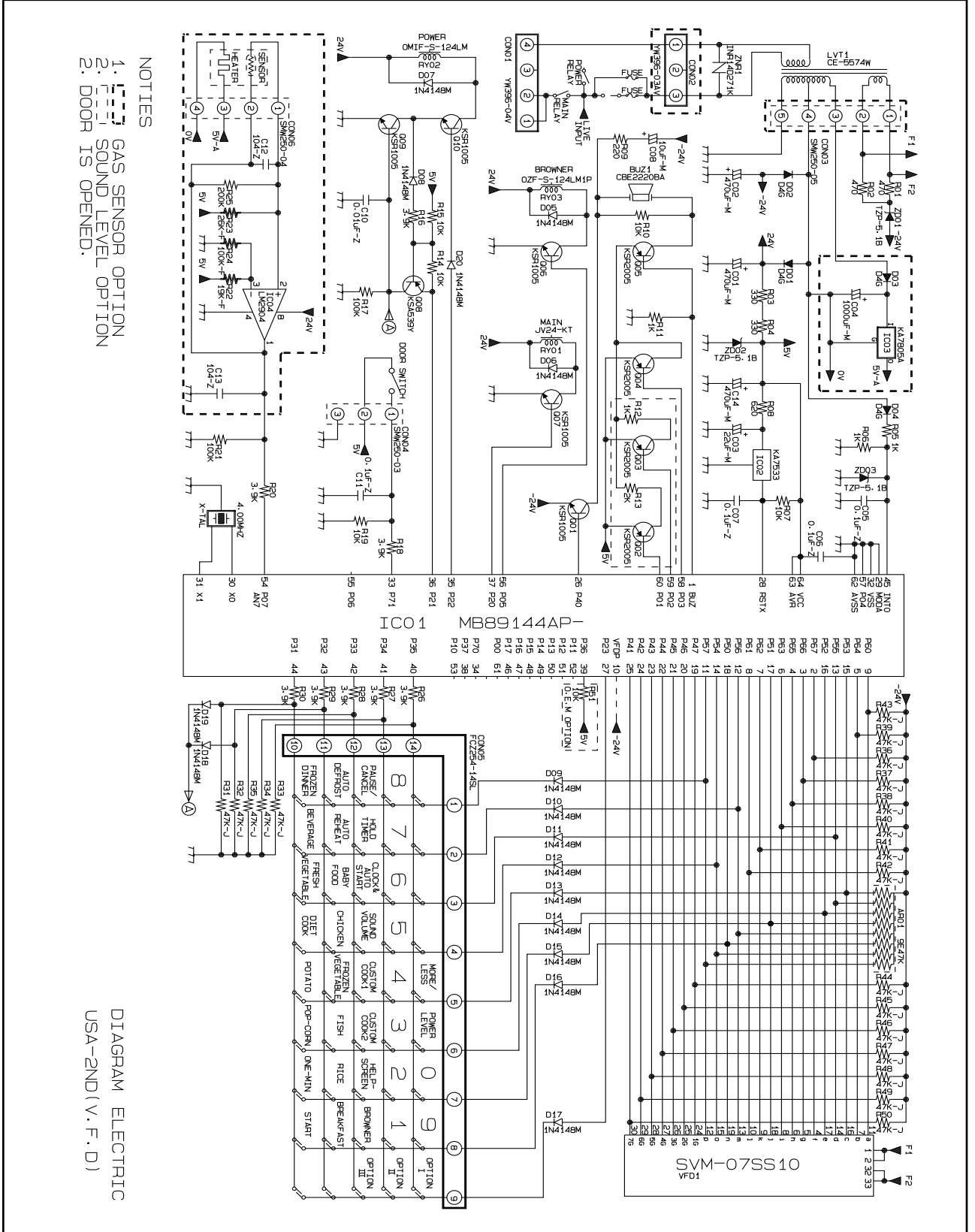

## 8-2 P.C.B Parts List

Parts No.	Description / Specification	Q'ty	Remarks
0401-001002	DIODE-SWITCHING;1N4148M,100V,200mA,500mW	16	D05-20
0402-000559	DIODE-RECTIFIER;D4G,400V,1A,T-1	1	D01,2,4
0501-000283	TR-SMALL SIGNAL;-;PNP,400mW,TO-92,TP,120	1	Q08
1405-000129	VARISTOR;270V,4500A,17x12mm,TP	1	ZNR1
2202-000121	C-CERAMIC,MLC-AXIAL;100pF,10%,50V,Y5P,1.	1	C09
2202-000127	C-CERAMIC,MLC-AXIAL;10nF,+80-20%,25V,Y5V	1	C10
2202-000780	C-CERAMIC,MLC-AXIAL;100nF,+80-20%,50V,Y5	1	C05
2202-000780	C-CERAMIC,MLC-AXIAL;100nF,+80-20%,50V,Y5	1	C06
2202-000780	C-CERAMIC,MLC-AXIAL;100nF,+80-20%,50V,Y5	1	C07
2202-000780	C-CERAMIC,MLC-AXIAL;100nF,+80-20%,50V,Y5	1	C11
2401-000247	C-AL;100uF,20%,10V,GP,6.3x11mm,5mm,	1	C14
2401-000466	C-AL;10uF,20%,35V,GP,5x7mm,5mm,	1	C08
2401-001412	C-AL;470uF,20%,35V,GP,10x16,5mm,TP	1	C01
2401-001412	C-AL;470uF,20%,35V,GP,10x16,5mm,TP	1	C02
2802-000161	RESONATOR-CERAMIC;4MHz,0.5%,TP,10.0x5.0x	1	X-TAL
3501-001014	RELAY-POWER;24V,21.8mA,17A,1FormA,20mS,8	1	RY02
3501-001016	RELAY-MINIATURE;JV24-KT 24V,12.5MA,5A 1F	1	RY01
3708-000529	CONNECTOR-FPC/FC/PIC;FCZ254-14SL,BLK 14P	1	CON05
3711-000881	CONNECTOR-HEADER;SMW250-03,WHT BOX,3P,1R	1	CON04
A1000-0218	R-CARBON;RD 1/8 T 221-J	1	R09
A1000-0220	R-CARBON;RD 1/8 T 621-J	1	R08
A1000-0225	R-CARBON;RD 1/8 T 392-J	8	R16,18,20,26-30
A1000-0228	R-CARBON;RD 1/8 T 103-J	5	R07,10,14,15,19
A1000-0241	R-CARBON;RD 1/8 T 202-J	1	R13
A1000-0327	R-CARBON;RD 1/8 T 471-J	1	R01
A1000-0327	R-CARBON;RD 1/8 T 471-J	1	R02
A1000-0433	R-CARBON;RD 1/8 T 104-J	2	R17,21,
A1000-0473	R-CARBON;RD 1/8 T 102-J	1	R05,6,11,12
A1000-0598	R-CARBON;RD 1/8 T 473-J	20	R31-50
A1000-0620	R-CARBON;RD 1/2 T(S) 331-J	2	R03,4
A1104-0763	C-ELEC;CE 04 -40/85 16V T 220-M NP W/2 1	1	C03
A4060-0008	TR-W/RESISTOR;KSR1005 300MW 100MA 50V EB	1	Q1,6,7,9,10
A4060-0009	TR-W/RESISTOR;KSR2005 300MW -100MA -50V	1	Q2-5
A4106-0154	DIODE-ZENER;TZP5.1B 5.1/5.7V 40MA T 1W	3	ZD1-3
A6010-0461	CONNECTOR-WAFER;YW396-04V WHT	1	CON01
DE07-10035A	V.F.DISPLAY;SVM-07SS10 SEA	1	VFD1
DE09-30459A	IC-MCU;MB89143AP-159 8K DIP 64PIN	1	IC01
DE13-20009A	IC;KA7533 DIP	1	IC02
DE26-20144A	TRANS-L.V;DN-5574W,CE-5574W 120V 60HZ AC	1	LVT1
DE30-20016A	BUZZER;CBE2220BA STICK	1	BUZ1
DE39-60001A	WIRE-SO COPPER;PI0.6 SN T 52MM	25	J01-25
DE41-10330A	P.C.B-MAIN;FR-1 T1.6 W88 L163 USA-2ND	1	PCB
DE61-90053A	HOLDER-DIGITRON;PP-JI350 7G BLK	1	

# 9. Schematic Diagrams

## 9-1 Schematic Diagrams

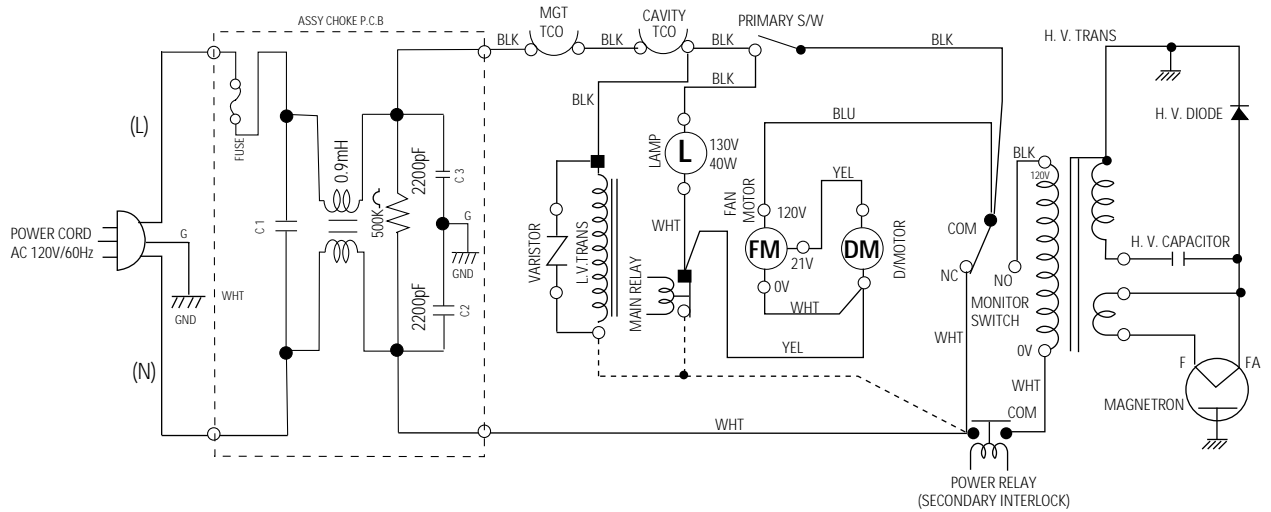

- 1. INPUT : 120V 60HZ
- 2. DOOR : OPEN
- 3. LAMP : ON
- 4. - - - - : P.C.B PATTERN
- 5. ■ : P.C.B IN/OUT POINT (CON1)

- WHT : WHITE
- BLK : BLACK
- YEL : YELLOW
- BLU : BLUE
- ORG : ORANGE
- G : GREEN

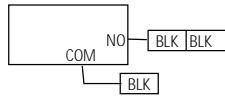

PRIMARY INTERLOCK SWITCH

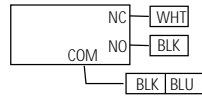

INTERLOCK MONITOR SWITCH

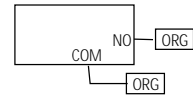

DOOR SENSING SWITCH

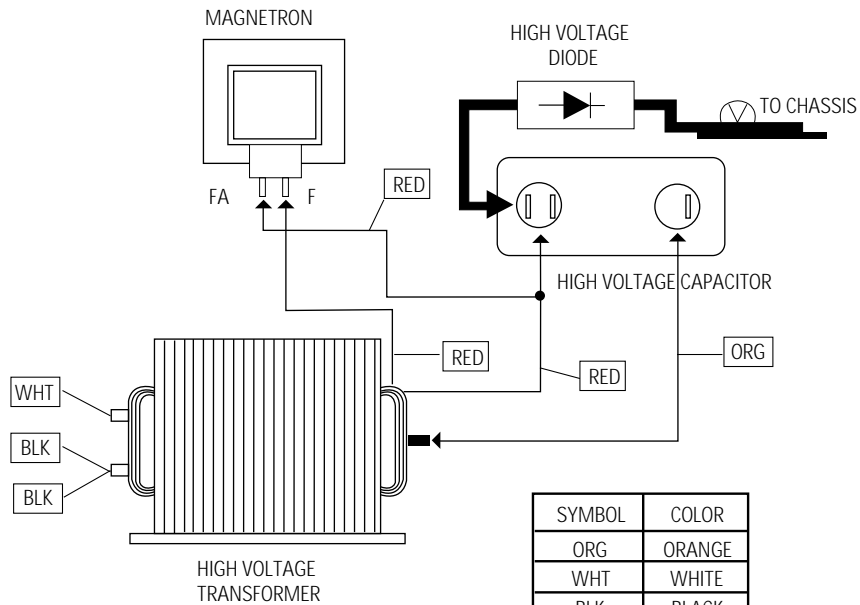

SYMBOL	COLOR
ORG	ORANGE
WHT	WHITE
BLK	BLACK
BLU	BLUE
RED	RED