



**OWNERS AND SERVICE MANUAL**  
**INNOVATIVE CONCEPTS IN ENTERTAINMENT INC.**  
10123 MAIN ST., CLARENCE, NY 14031  
SERVICE: 1-716-759-0360  
FAX: 1-716-759-0884  
E-MAIL: [service@icegame.com](mailto:service@icegame.com)  
WEBSITE: [www.icegame.com](http://www.icegame.com)

# TABLE OF CONTENTS

<b>SAFETY AND WARNINGS</b>	<b>3</b>
• Before You Begin	
• Installation	
• Warning	
<b>GAME SETUP AND FEATURES</b>	<b>4</b>
• Player Controls	
• Playing The Game	
• Initial Game Setup	
• Assembly - Main cabinet to Podium & Speakers	5
• Stool to Platform Assembly	6
<b>ADJUSTMENTS &amp; AUDIT MENU SYSTEM</b>	<b>8</b>
• Main Menu	
• Operator Adjustments	
• Game Adjustments	
• Ticket MECH adjustments	
• Coin Settings	
• Player Cost/ Payout	
• Volume	
• General Audits	
• Game Audits	
• Ticket Audits	
• System Audits	
• Coin Audits	
• Reset Menu	
• System Test	
<b>MAINTENANCE</b>	<b>15</b>
• Access the Computer	
• AC Power fuse	
• Power Supply Replacement and Adjustments	16
• Main and I/O board replacement	17
• Platform Lights replacement	18
• Marquee Bulbs replacement	19
• Cleaning	20
• Monitor Replacement	
• Speaker Replacement	
• Monitor Adjustments	21
• Deal No Deal and Suit case Buttons and bulbs	22
• Side Light Replacement	
• System Wiring both 110v and 220v	24
• Spare Parts List	28
<b>WARRANTY INFORMATION</b>	<b>29</b>

# SAFETY AND WARNINGS

## BEFORE YOU BEGIN

WARNING: WHEN INSTALLING THIS GAME, A GROUNDED A.C. RECEPTACLE MUST BE USED. FAILURE TO DO SO COULD RESULT IN INJURY TO YOURSELF OR OTHERS. FAILURE TO USE A GROUNDED RECEPTACLE COULD ALSO CAUSE IMPROPER GAME OPERATION, OR DAMAGE TO THE ELECTRONICS.

DO NOT DEFEAT OR REMOVE THE GROUNDING PRONG ON THE POWER CORD FOR THE SAME REASON AS GIVEN ABOVE. USING AN IMPROPERLY GROUNDED GAME COULD VOID YOUR WARRANTY.

HAVE A QUALIFIED ELECTRICIAN CHECK YOUR A.C. RECEPTACLE TO BE SURE THE GROUND IS FUNCTIONING PROPERLY.

## INSTALLATION

The game comes ready to play with just a few simple things to keep in mind.

1. Plug the game into the A.C. outlet and turn on power to the game. The switch for the game is located on a power module on the outside rear of the game.

THIS GAME IS DESIGNED TO DISSIPATE STATIC ELECTRICITY THROUGH THE GROUNDING PLANE OF THE GAME. IF THE A.C. GROUND DOES NOT WORK, THE GAME COULD DISCHARGE STATIC ELECTRICITY THROUGH THE GAME CIRCUITRY, WHICH COULD CAUSE DAMAGE.

2. Make sure the game is level after installation. It is necessary to make sure the game is level for safety concerns.
3. Check that the A.C. voltage rating on the back of the game matches the A.C. voltage of your location.

THE POWER SUPPLY IS NOT VOLTAGE ADJUSTABLE. TO OPERATE THE GAME AT VOLTAGES OTHER THAN THOSE IT WAS DESIGNED FOR. PLEASE CONTACT OUR SERVICE DEPARTMENT FOR VOLTAGE CONVERSION INFORMATION.

## WARNING

DO NOT remove any of the components on the main board (e.g. compact flash and eproms) while the game is powered on. This may cause permanent damage to the parts and the main board. Removing any main board component part while powered on will void the warranty.

**NOTE: THIS GAME IS INTENDED FOR INDOOR USE ONLY.**  
**ON THE BACK PANEL OF THE GAME: WARNING: SHOCK HAZARD - DO NOT OPEN. REFER SERVICING TO SERVICE PERSONNEL.**

# GAME SETUP AND FEATURES

## Player Controls

To begin the game, insert the proper number of credits. **DEAL OR NO DEAL** is a one player game. Select **DEAL** or **DOUBLE DEAL to begin the game.** Selecting Double Deal doubles the amount of tickets!

## Playing the Game

The object of the game is to wind up with the highest value deal as possible. The player selects his/her case. Then the player must determine which cases he/she feels hold the lowest value. By selecting the cases, the player eliminates potential deal values. Round to round the banker will offer a deal value that the player is entitled to take. If a deal is taken, the game dispenses the deal value in tickets and the game ends. If the player does not take the bankers deal value throughout the game, he/she will be left with the value inside his/her case. The game will dispense the value of tickets in his/her case and the game ends.

## Initial Game Setup

The game is setup at the factory with the recommended factory settings. The settings may be adjusted by accessing the menu system. The game's menu system is a series of on screen menus that allow the operator to setup or adjust the settings. Each menu provides the ability to adjust a specific setting or access another menu with other game settings.

To access the menu system press the program button inside the coin door. The main menu will appear on the game screen. To navigate the menu system use volume up to scroll up and volume down to scroll down. To select a menu option use the program button. Use the volume up and down buttons to scroll through the setting levels on specific menu option screens. Use the program button to select and save desired setting level.

## Assembly - Main cabinet to podium

Start by attaching all electrical connections first. Now slide the podium flush to the main cabinet and attach the side mounting brackets with three mounting screws. To attach the side speakers onto the main cabinet first connect the two wire connector to the speaker. Then install the two top and bottom screws. Finally install the three back screws to complete the mounting of the speaker unit. See diagrams below and on the next page.

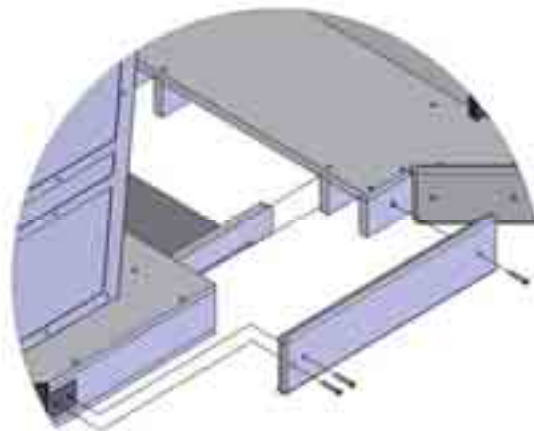

# GAME SETUP AND FEATURES

Assembly - Main cabinet to podium cont.

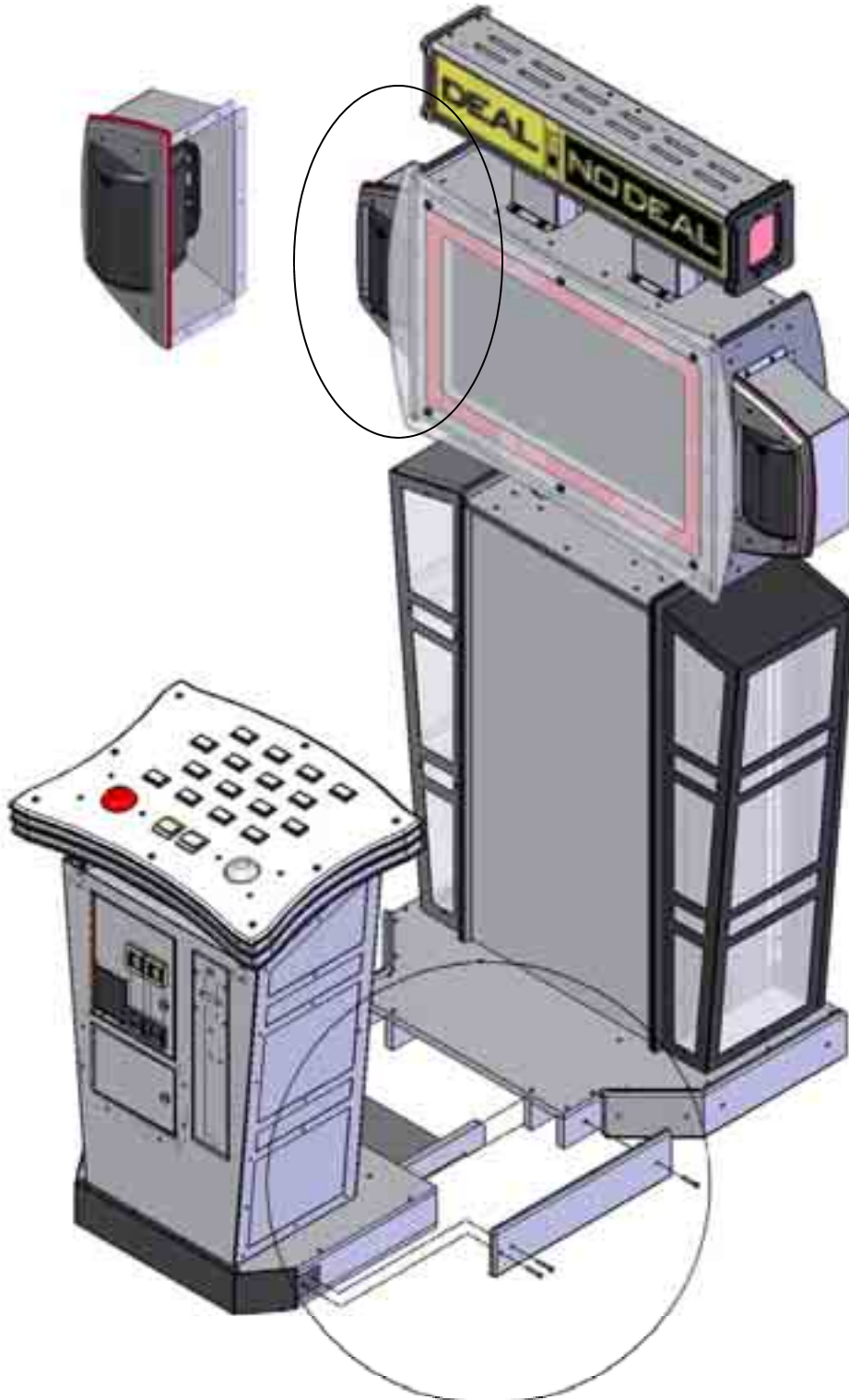

# GAME SETUP AND FEATURES

## Stool to Platform Assembly

If you purchased the Deluxe version of Deal or No Deal you will need to attach the stool onto the base by lifting the bottom collar ring up on the stool and exposing the four mounting holes. See pictures below. Insert four washers and four bolts through the mounting holes and tighten. See diagram below. Replace the collar. See picture below.



## Platform to Cabinet Assembly

Now attach the stool assembly to the podium by removing the front bottom bezel. Now slide the stool assembly into the cabinet and attach two mounting screws on both sides. See pictures below and diagram on the next page.



# GAME SETUP AND FEATURES

Platform to Cabinet Assembly cont.

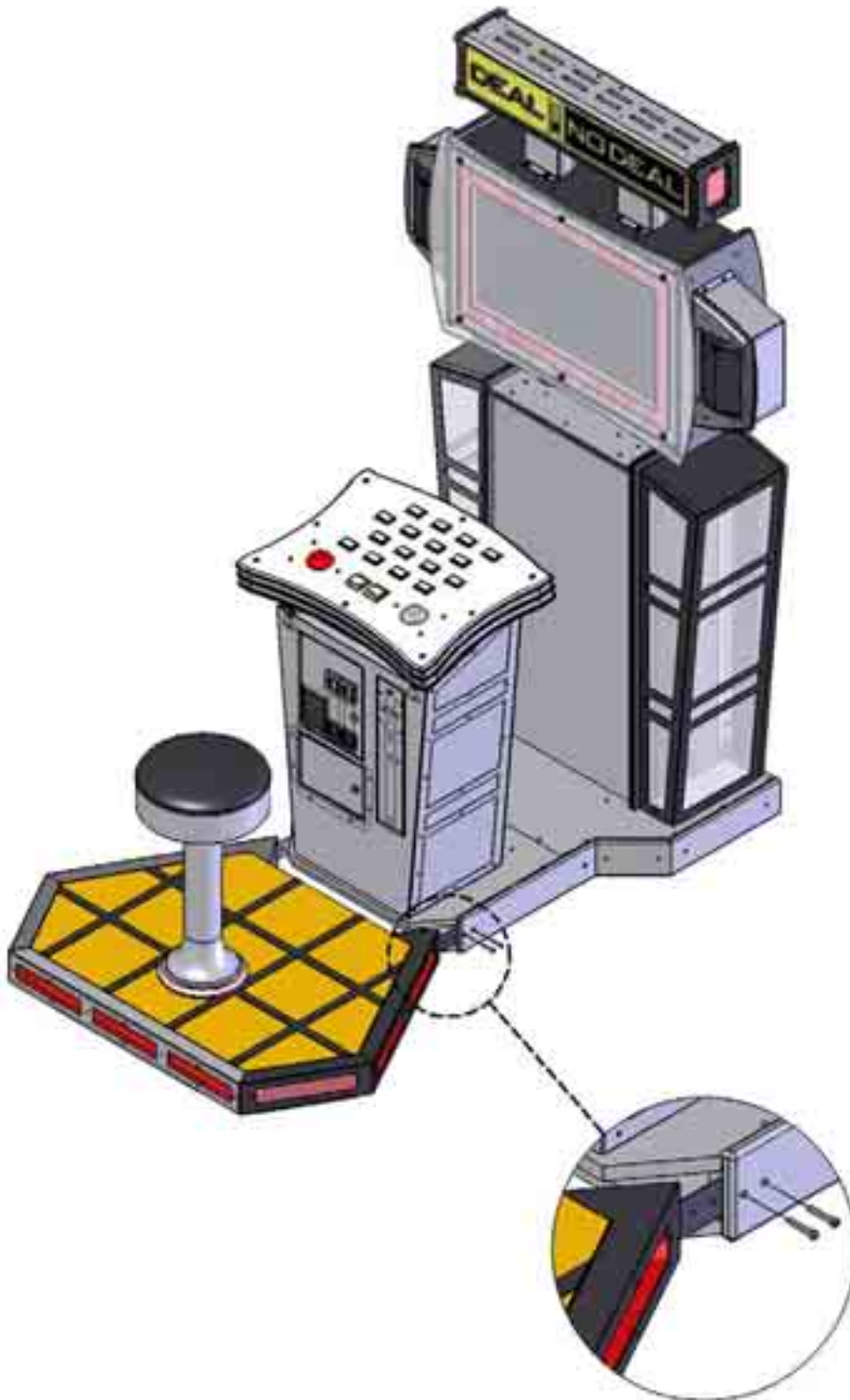

# DIAGNOSTIC, ADJUSTMENTS & AUDIT MENU SYSTEM

## MAIN MENU

### **OPERATOR ADJUSTMENTS**

- *adjust various game play/operation settings*

### **GENERAL AUDITS**

- *view game/coin/ticket audit data*

### **RESET MENU**

- *reset game/coin/ticket audits*

### **SYSTEM TESTS MENU**

- *perform various system tests/diagnostics*

## Main Menu - OPERATOR ADJUSTMENTS

### **GAME ADJUSTMENTS**

- adjust game play settings

### **TICKET MECH ADJUSTMENT**

- turn the ticket mechanism on/off

### **COIN ADJUSTMENTS**

- adjust the currency type and coin switch values

### **PLAYER COST / PAYOUT**

- adjust the cost of the game and the level of payout

### **VOLUME**

- adjust the volume for the game

## Main Menu - Operator Adjustments - GAME ADJUSTMENTS

### **FIXED TICKET MODE**

- XXX

**DEFAULT=OFF**

### **COUNTDOWN TIMER**

**DEFAULT = 10**

- the amount of time that the user has to make an input before the game makes an auto-input.  
The value ranges from 3 to 20 seconds [min = 3, max = 20]

### **COUPONS OR TICKETS DEFAULT = TICKETS**

- the prizes given out by the game can be labeled as either TICKETS or COUPONS

### **SHUFFLE GAME**

- XXX

**DEFAULT=OFF**

### **SHUFFLE SPEED**

- XXX

**DEFAULT=100%**

## Main Menu - Operator Adjustments - TICKET MECH ADJUSTMENT

### **TICKET OUTPUT**

- enables/disables output from the ticket mechanism. [ON / OFF]

**DEFAULT = ON**



# DIAGNOSTIC, ADJUSTMENTS & AUDIT MENU SYSTEM

## Main Menu - Operator Adjustments - COIN SETTINGS

### **FREEPLAY**

-allow the game to be played without credits  
[ON / OFF]

**DEFAULT = OFF**

### **CURRENCY TYPE**

- the currency type can be set to a variety of world currency values. the default is the US dollar.

**DEFAULT = DOLLAR**

### **CURRENCY UNIT VALUE**

-the unit value of a single credit.

**DEFAULT = \$0.25**

### **COIN 1 VALUE**

- the amount of credits given by one pulse from coin switch #1

**DEFAULT = \$0.25**

### **COIN 2 VALUE**

- the amount of credits given by one pulse from coin switch #2

**DEFAULT = \$0.25**

### **COIN 3 VALUE / DBV PULSE**

- the amount of credits given by one pulse from coin switch #3 or the dollar bill acceptor.

**DEFAULT = \$1.00**

### **MAXIMUM CREDITS**

- the maximum number of credits allowed by the machine. if more credits than this are inserted, the internal coin meters will still tick, but the game will ignore the input.

**DEFAULT = \$500.00**

### **CREDIT VALUE (Coins Only)**

- when coins are selected as the currency type, there is an added option for a credit value. this allows the operator to set an alternate value for each coin. for example, if a token was worth only \$0.05, the credit value would be set to 0.05.

**DEFAULT = \$0.25**

# DIAGNOSTIC, ADJUSTMENTS & AUDIT MENU SYSTEM

## Main Menu - Operator Adjustments - PLAYER COST / PAYOUT

### **PAY MODEL**

**DEFAULT = PAY UP FRONT**

- the game can be set to PAY UP FRONT, where there is a one-time cost to play the game, or PAY PER ROUND, where an individual price can be set for each round of play, and the player is prompted to enter more money as the game goes on.  
[PAY UP FRONT / PAY PER ROUND]

### **GAME START COST**

**DEFAULT = \$1.00**

- cost to start the game [min = FREE, max = \$25.00]

### **GAME START COST (DOUBLE DEAL)**

**DEFAULT = \$2.00**

- cost to start the Double Deal game.  
(note: the Double Deal mode is the same as the regular game, except that all the payout values are doubled. the cost of the Double Deal game should almost always be twice the cost of the regular game.)  
[min = FREE, max = \$25.00]

### **TICKET VALUE**

**DEFAULT = \$0.01**

- the value of a single ticket in relation to a unit of currency. the default setting is 0.01, which means that one ticket equals one cent.  
[min = \$0.00, max = \$1.00]

### **HIGHEST PAYOUT VALUE**

**DEFAULT = 200**

- the value of a single ticket in relation to a unit of currency. the default setting is 0.01, which means that one ticket equals one cent.  
[SETTINGS = 100 / 200 / 500 / 1000]

## **(THE FOLLOWING ADJUSTMENTS ONLY APPEAR IF SET TO "PAY PER ROUND")**

### **ROUND 2 COST**

**DEFAULT = FREE**

### **ROUND 3 COST**

**DEFAULT = FREE**

### **ROUND 4 COST**

**DEFAULT = FREE**

### **ROUND 2 COST (DOUBLE DEAL)**

**DEFAULT = FREE**

### **ROUND 3 COST (DOUBLE DEAL)**

**DEFAULT = FREE**

### **ROUND 4 COST (DOUBLE DEAL)**

**DEFAULT = FREE**

- if PAY PER ROUND is selected as the pay model, the operator has the option to set individual costs for each round of play. if a particular round is set to FREE, the player is allowed to play that round without being prompted to enter more credits.

# DIAGNOSTIC, ADJUSTMENTS & AUDIT MENU SYSTEM

## Main Menu - Operator Adjustments - VOLUME

### **GAME VOLUME**

- in-game volume [min = 0, max = 32]

**DEFAULT = 24**

### **ATTRACT VOLUME**

- volume of the attract mode [min = 0, max = 32]

**DEFAULT = 24**

### **MINIMUM VOLUME**

- the lowest level that both the game and attract mode volumes can be set to. [min = 0, max = 32]

**DEFAULT = 4**

### **ATTRACT SOUNDS**

- how frequently the sounds will play while in attract mode. [SETTINGS = OFF / OCCASIONALLY / ALWAYS]

**DEFAULT = OCCASIONALLY**

## Main Menu - GENERAL AUDITS

### **GAME AUDITS**

- audits for total number of plays, game time, etc.

### **TICKET AUDITS**

- audits for the number of tickets won, average tickets, number of tickets owed, etc.

### **SYSTEM AUDITS**

- audits for play time, up time, etc.

### **COIN AUDITS**

- audits for the number of coins in, etc.

ALL AUDITS ARE VISIBLE IN THE ATTACHED SCREENSHOTS.

\*\*\*\*ONE CHANGE IS CURRENTLY BEING MADE: UNDER "COIN AUDITS", "BONUS COINS" WILL NOT BE PRESENT IN THE FINAL BUILD.\*\*\*\*

# DIAGNOSTIC, ADJUSTMENTS & AUDIT MENU SYSTEM

## Main Menu - General Audits - GAME AUDITS

### **TOTAL PLAYS**

- total number of games played

### **TOTAL DEAL GAMES**

-- total number of standard games played

### **TOTAL DOUBLE DEAL GAMES**

- total number of "Double Deal" games played

### **TOTAL WON HIGHEST**

- number of times the player has won the highest possible value

### **TOTAL WON LOWEST**

- number of times the player has won the lowest possible value

### **AVERAGE GAME TIME**

- the length of the average game, specified in minutes

### **TOTAL GAME TIME**

- the cumulative time the game has been played

### **TOTAL DEALS**

- number of times players have chosen the "Deal"

### **TOTAL NO DEALS**

- number of times players have chosen "No Deal"

## Main Menu - General Audits - TICKET AUDITS

### **TOTAL TICKETS DISPENSED**

- the total number of tickets given out by the game

### **AVERAGE TICKETS PER PLAY**

- the average number of tickets given out each game

### **CURRENT PAYOUT PCT**

- the current payout percentage of the game. this number changes as people play the game, and the game tries to get this value as close to the target payout as possible.

### **TOTAL TICKETS (500 GAMES)**

- the total number of tickets dispensed in the past 500 games

### **AVG. TICKETS (500 GAMES)**

- the average number of tickets given out during the past 500 games

### **PAYOUT PCT. (500 GAMES)**

- the payout percentage for the past 500 games

### **TICKETS OWED**

- how many tickets are currently owed to the player. this number will be non-zero if there has been some kind of ticket mechanism error (i.e. out of tickets, ticket jam)

# DIAGNOSTIC, ADJUSTMENTS & AUDIT MENU SYSTEM

## Main Menu - General Audits - SYSTEM AUDITS

### **PLAY TIME**

- total play time logged on the game

### **UP TIME**

- length of time the game has been powered on

### **WATCHDOGS**

- the number of times the game has forced itself to reset (power cycle)

### **EXCEPTIONS**

- the number of times the game has detected a software error of type #1

### **BAD TRAPS**

- the number of times the game has detected a software error of type #2

## Main Menu - General Audits - COIN AUDITS

### **TOTAL COIN 1**

- total number of coins read by coin counter #1

### **TOTAL COIN 2**

- total number of coins read by coin counter #2

### **TOTAL COIN 3 (DBV)**

- total number of coins read by coin counter #3 (often used for dollar bill acceptors)

### **LIFETIME COIN COUNT**

- cumulative coin count for all three coin counters

### **SERVICE CREDITS**

- total number credits added via the "service credits" button

## Main Menu - RESET MENU

### **RESET GAME AUDITS**

- reset the game audits (total plays, current payout, etc.)

### **RESET CREDITS**

- reset the number of credits currently in the game

### **RESET COIN COINTERS**

- reset the coin audits

### **RESET ADJUSTMENTS**

- reset the game adjustments (game cost, highest payout, etc.)

### **RESET TICKETS**

- reset the ticket audits

### **FACTORY RESET**

- reset all audits (game, credits, coin, adjustments and tickets)

# DIAGNOSTIC, ADJUSTMENTS & AUDIT MENU SYSTEM

## Main Menu - SYSTEM TESTS

### **VERSION LIST**

- display the individual software versions for the game

### **SWITCH TEST**

- perform a switch test for coin counters, start, volume, test and service buttons

### **SCREEN TESTS**

- perform a series of screen tests such as color and grid adjustment

### **SOUND TEST**

- play a series of test sounds to diagnose audio problems

### **FILE TEST**

- perform a test to validate all of the files used by the game

### **COIN METER TEST**

- tick the coin meter once

### **TICKET DISPENSER TEST**

- dispense one ticket from the ticket mechanism

### **DIPSWITCH SETTINGS**

- read the state of the eight dip switches on the IO board

### **START BUTTON LAMPS**

- alternately flash the two starts buttons

### **WATCHDOG TEST**

- test the reset capability of the IO board. NOTE: this will reset the game!

### **LPT SWITCH TEST**

- perform a switch & lamp test for the 16 case buttons and Deal / No Deal buttons.

ALL AUDITS ARE VISIBLE IN THE ATTACHED SCREENSHOTS.

# Maintenance

## Access the Computer

Remove the back cover and slide the computer drawer out. You can access the CDROM drive from the front of the computer. To replace the computer remove the two screws that hold the computer clamp down to the drawer. Remove all connectors to the computer before removing. See picture below.



## AC Power Fuse

Located in the power module is a 6 amp slow blow fuse. To check or replace the fuse pull the tab with the label out. There is only one fuse installed. See diagram below.

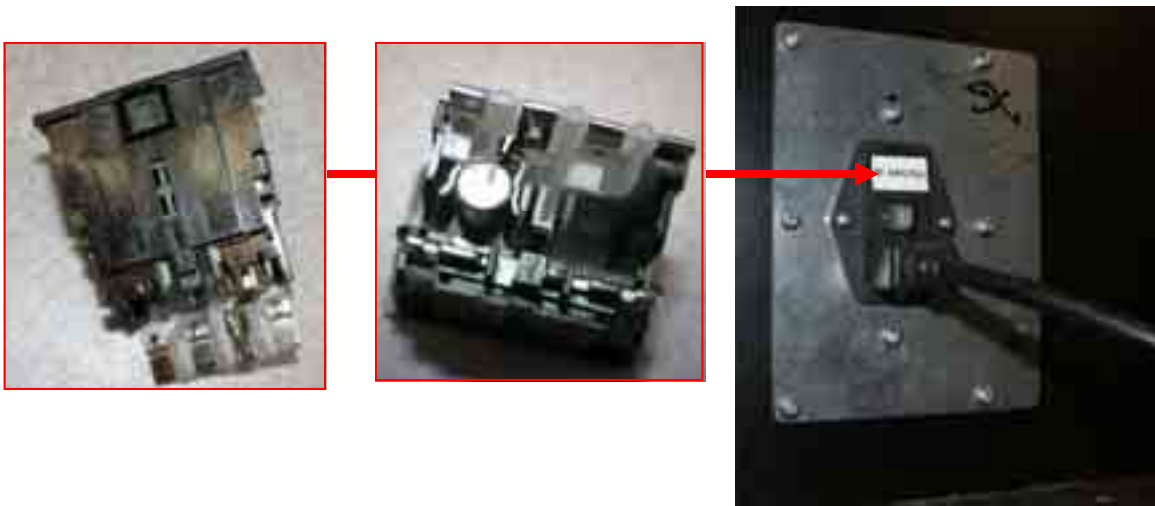



# Maintenance

## Power Supply Adjustment/Replacement

The power supply is accessed through the back of the game. Remove the back door panel to gain access to the power supply.

To replace the power supply remove the two mounting screws and all wires connecting to the power supply. Take note in which wires go into which connector before removing them. Replace the power supply with same type of unit and reconnect all wires matching their previous locations then install the two mounting screws.

To adjust the power supply turn the adjustment pot located at the bottom of the power supply until +5 is between +4.95 – 5.10. To measure the power supply's voltage place the positive lead on the red wire and the negative lead on the black wire. Set your meter to DC voltage. See pictures below.

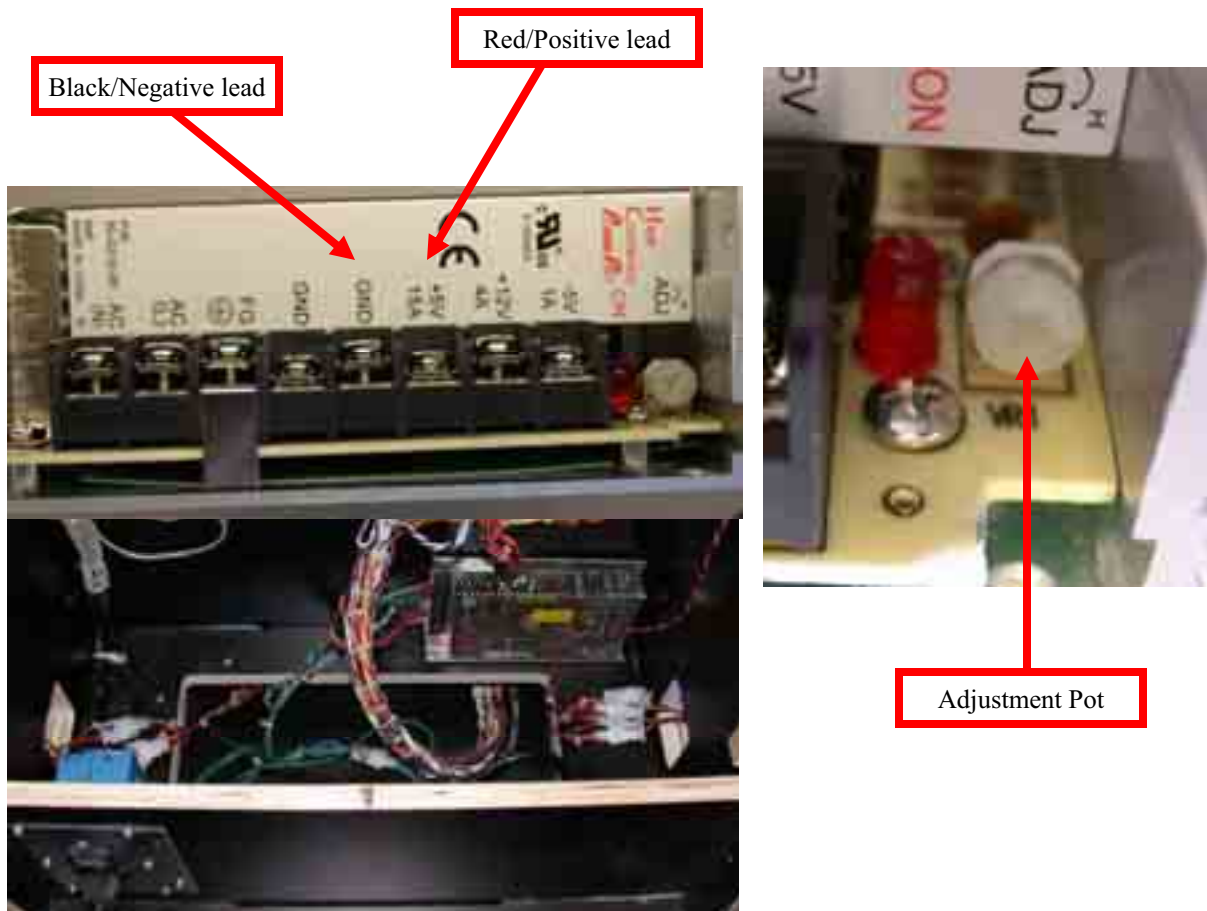

# Maintenance

## Main Board and I/O Replacement

To Remove the main board, unplug the JAMMA connector, serial cable (P2), audio cable (P8), and p1. Now remove the four plastic hex nuts. Assembly in reverse.

To remove the I/O board, unplug connectors P1, J2, J3, J4, J5, J6, J7, and J8. Remove the four plastic hex nuts. Assembly in reverse.

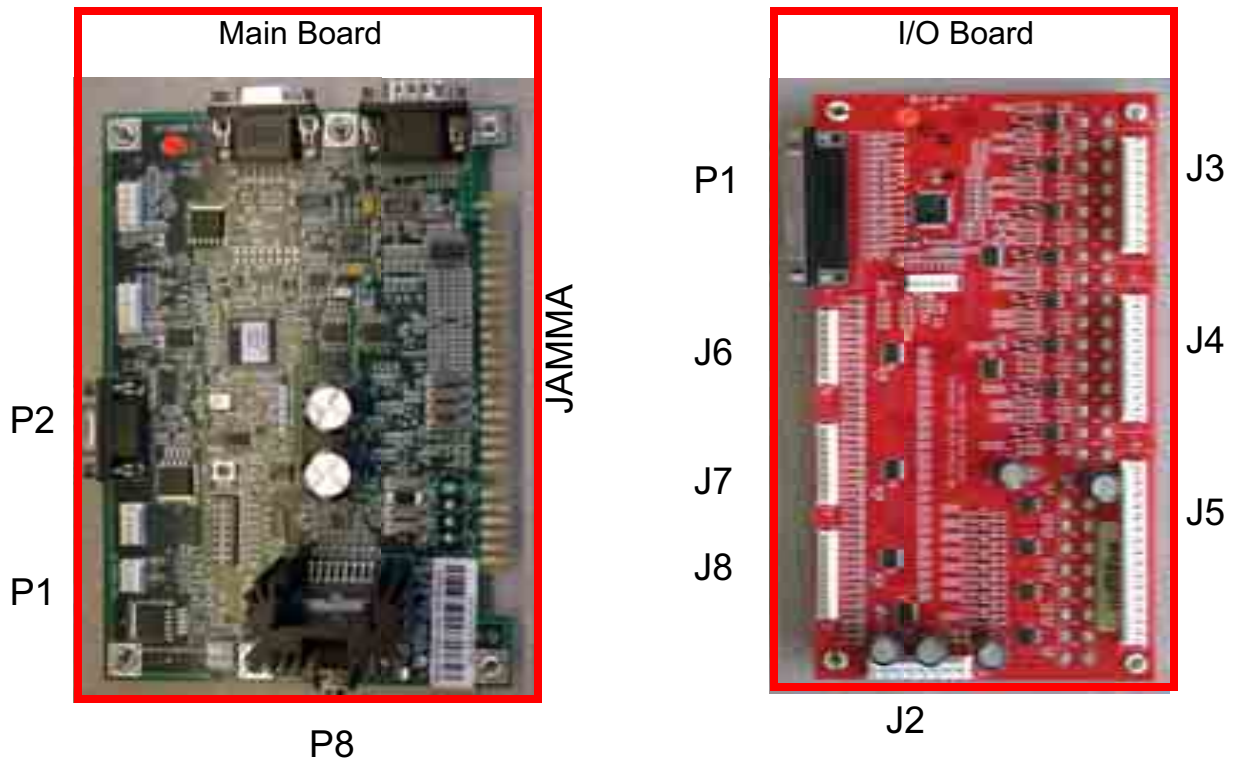

# Maintenance

## Platform Light Bulb Replacement

Remove the two strips shown below to access the top screws that hold the floor to the stage. Now remove the floor. You can now access the fluorescent bulbs. To replace bulbs 2,3, and 4 press the red button, remove the plastic retainers, lift up, and slide out as shown below. To replace bulbs 1 and 5 press the red button, remove the plastic retainers, and lift up and out as shown below.

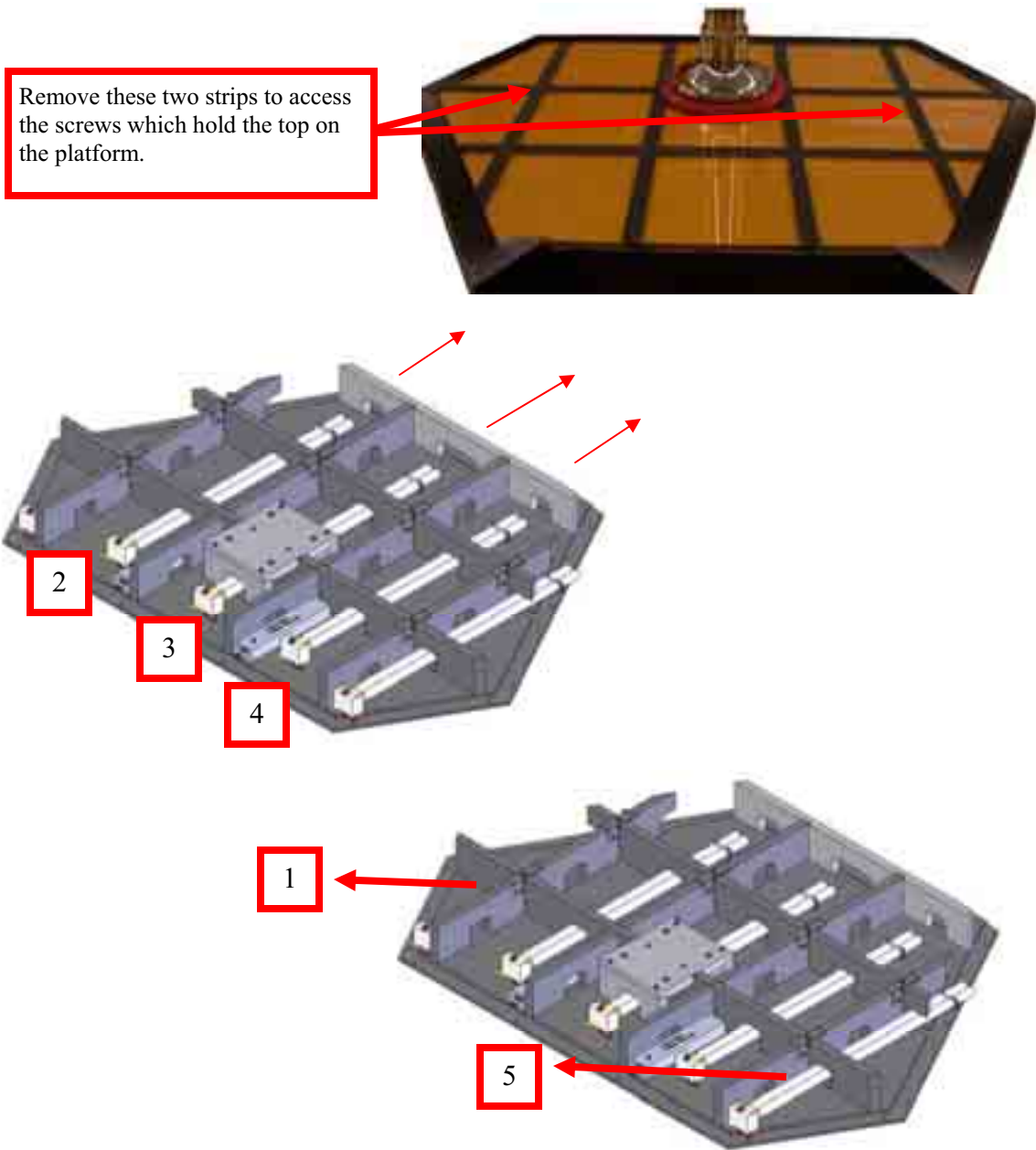

# Maintenance

## Marquee Bulb Replacement

To replace the fluorescent bulbs inside the marquee, remove the back panel by removing the upper and lower bolts from behind only. The bulbs are mounted onto this panel. Remove the plastic retainer clips and press the red buttons to eject the bulbs. Replace in reverse order. See Red circle below.

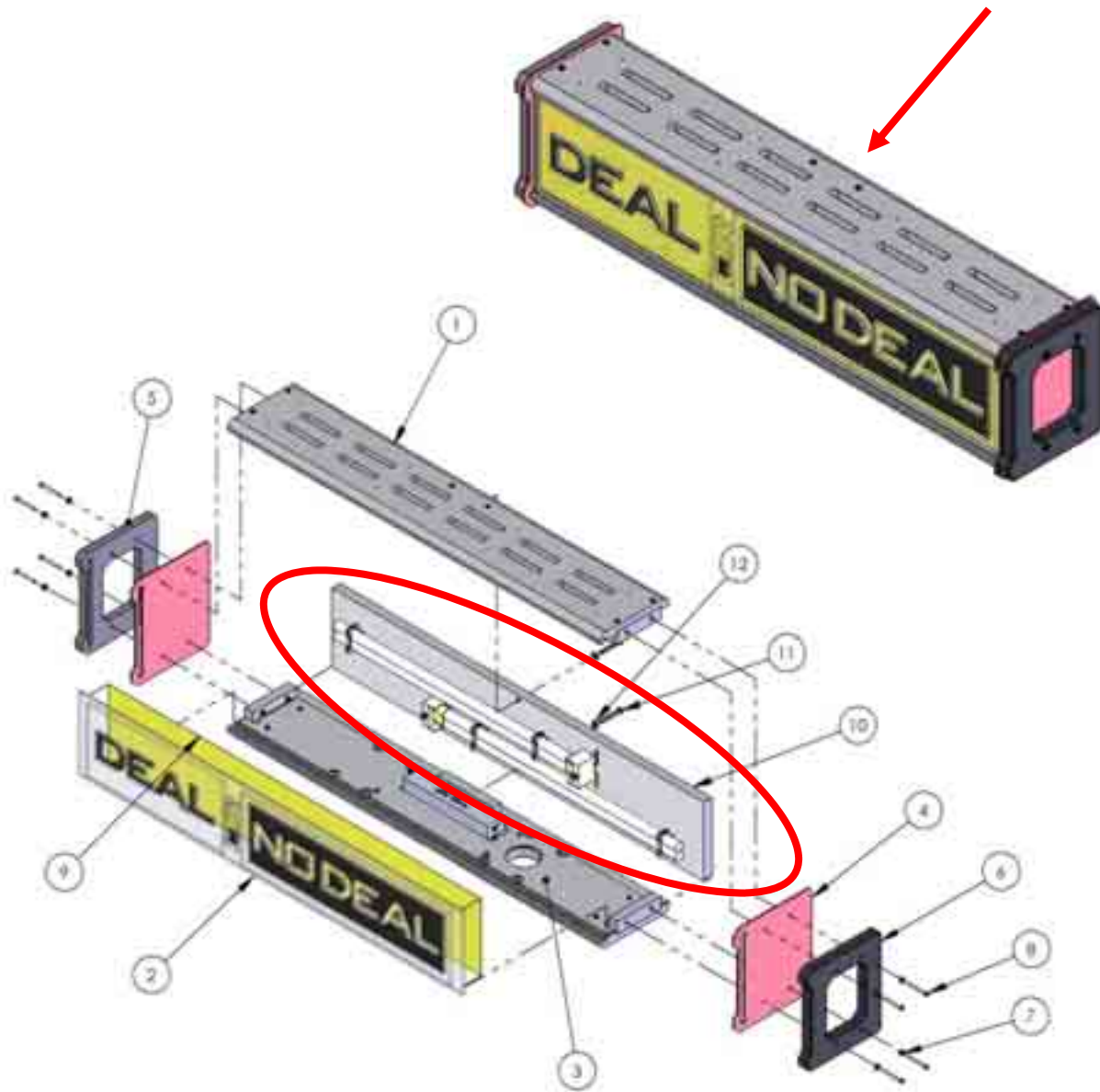

# Maintenance - Monitor Enclosure

## Monitor Replacement

To access the monitor, remove the six front screws shown below. Remove the front plastic and bezel. Now remove the mounting screws that hold the monitor to the cabinet. See diagram below

## Speaker Replacement

The speaker is accessed through the front of the assembly as shown below. Unscrew the four security screws and remove the front cover. Now remove the two nuts holding the speaker to the speaker housing. Unplug the speaker wire connection. Assembly in reverse. See diagram below.

**\*\* Warning \*\***

Use a soft lint free cloth to clean the plastic. Do not use ammonia based glass cleaners on clear plastic surfaces. Doing so will cause the plastic to fog over a period of time. Any ammonia free glass cleaner is recommended. Novus (cleaner #1) makes a special plastic cleaner that reduces static build up and restores a glass shine back to the plastic.

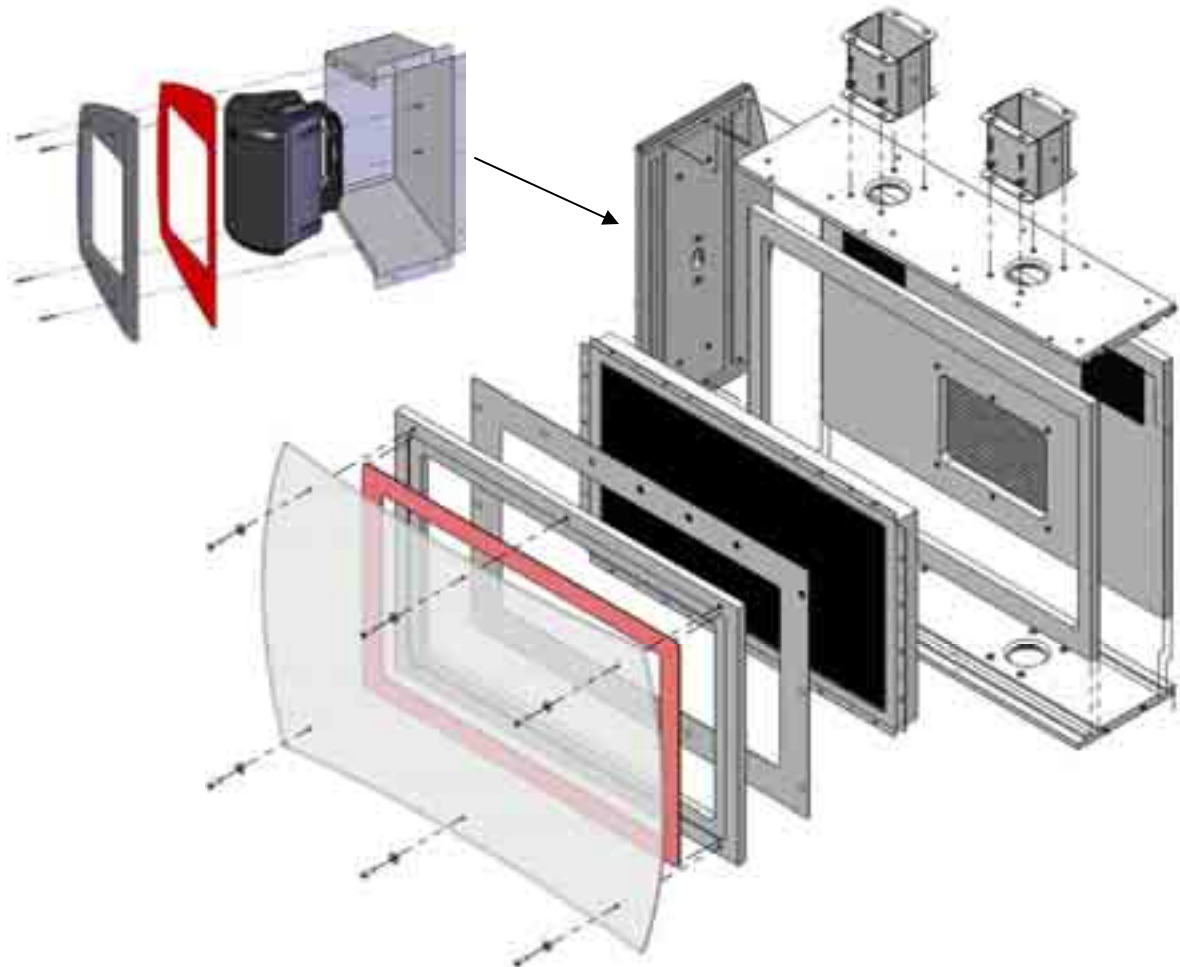



# Maintenance - Monitor Enclosure

## Monitor Adjustments

The controls of the monitor are accessed through the back of the monitor cabinet directly underneath the black label. The configuration of the buttons are in the same pattern printed. See pictures below.

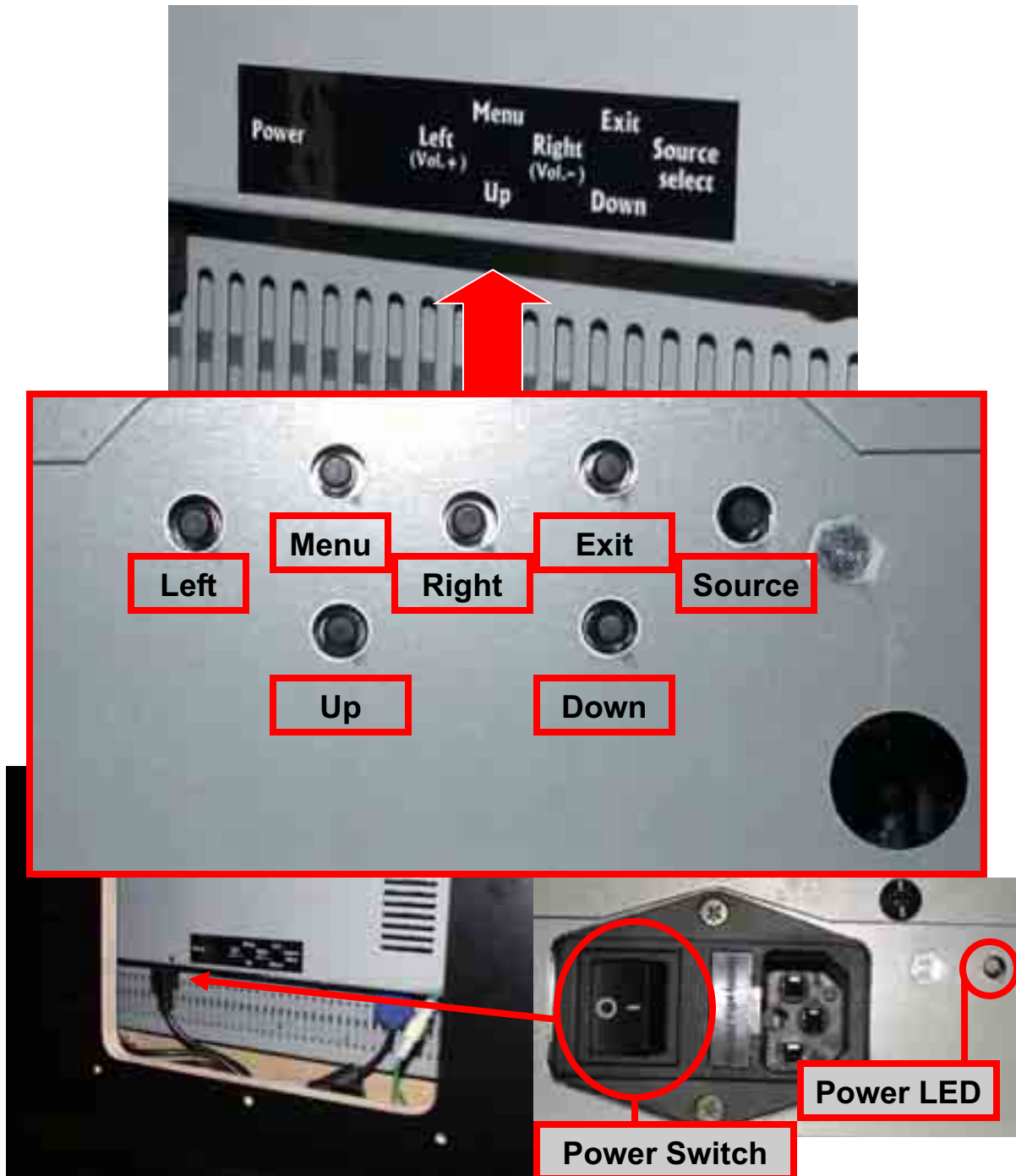

# Maintenance - Buttons

## Deal No Deal buttons

### Bulbs:

The Fluorescent bulbs are 110V ac and should only be replaced with the power off. Do not replace with incandescent type bulbs as the socket is not designed for this and is a fire hazard. When replacing use ICE Part numbers 8980 (red) and 8981 (white). To access the bulbs remove the two switches holding the metal bracket with the bulb socket on it. Now slide the bracket out and replace the bulb. Assemble in reverse. See diagram below.

### Switches:

The MEGA switch is made up with four smaller switches acting as one. When replacing the switch it is important to connect the normally open lead of the switch and ground. No wire should connect to Normally closed. When testing switches, your meter should read less than a ohm with it set to ohms test. There are two different switch assemblies used. ICE part number DN2006R (red) and DN2006W (white).

## Suit Case Buttons

### Bulbs and Switches:

The bulbs used in the suit cases are 12volt DC LEDs. They are glued in the socket and cannot be removed. You must replace this as a assembly. The ICE part numbers are DN2004S01 through DN2004S16. These are connected Normally open and no wire should be connected to Normally closed lead. When testing switches, your meter should read less than a ohm with it set to ohms test. The positive wire (orange) must connect to the + lead on the LED bulb. The yellow with a color strip is the - on the LED bulb. The Yellow start buttons are DN2005DD (double deal) and DN2005S (Deal).

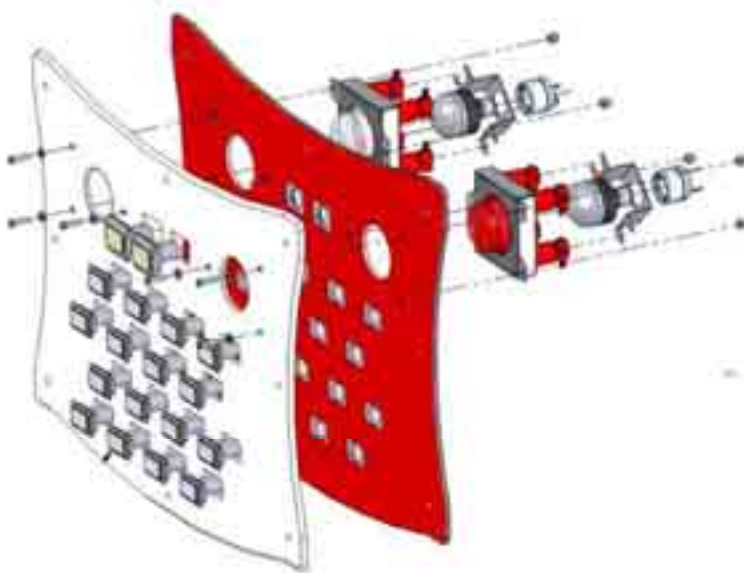

Remove these buttons to remove bulb socket bracket.





# Maintenance - Cabinet Mood Lighting

## Side Light Replacement

Your cabinet changes color depending on the action of the game. To accomplish this LED technology is used. There are three separate colors of LED strips which look the same. It is important to replace the color strips with the correct color. To access the strips, remove the back side panels. The LED strips are mounted on this panel. Refer to the diagram below for correct part numbers when ordering.

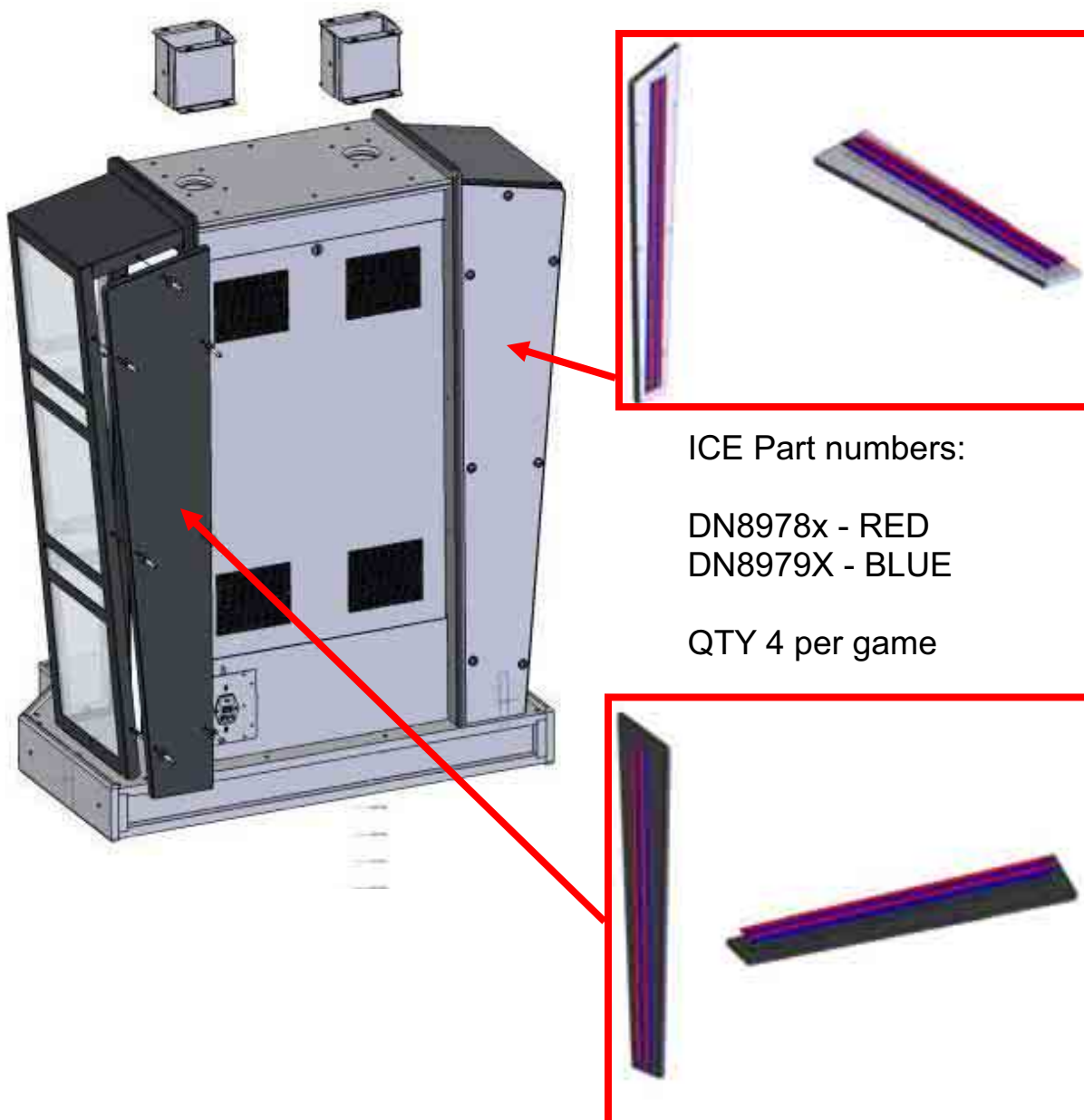

ICE Part numbers:

DN8978x - RED

DN8979X - BLUE

QTY 4 per game

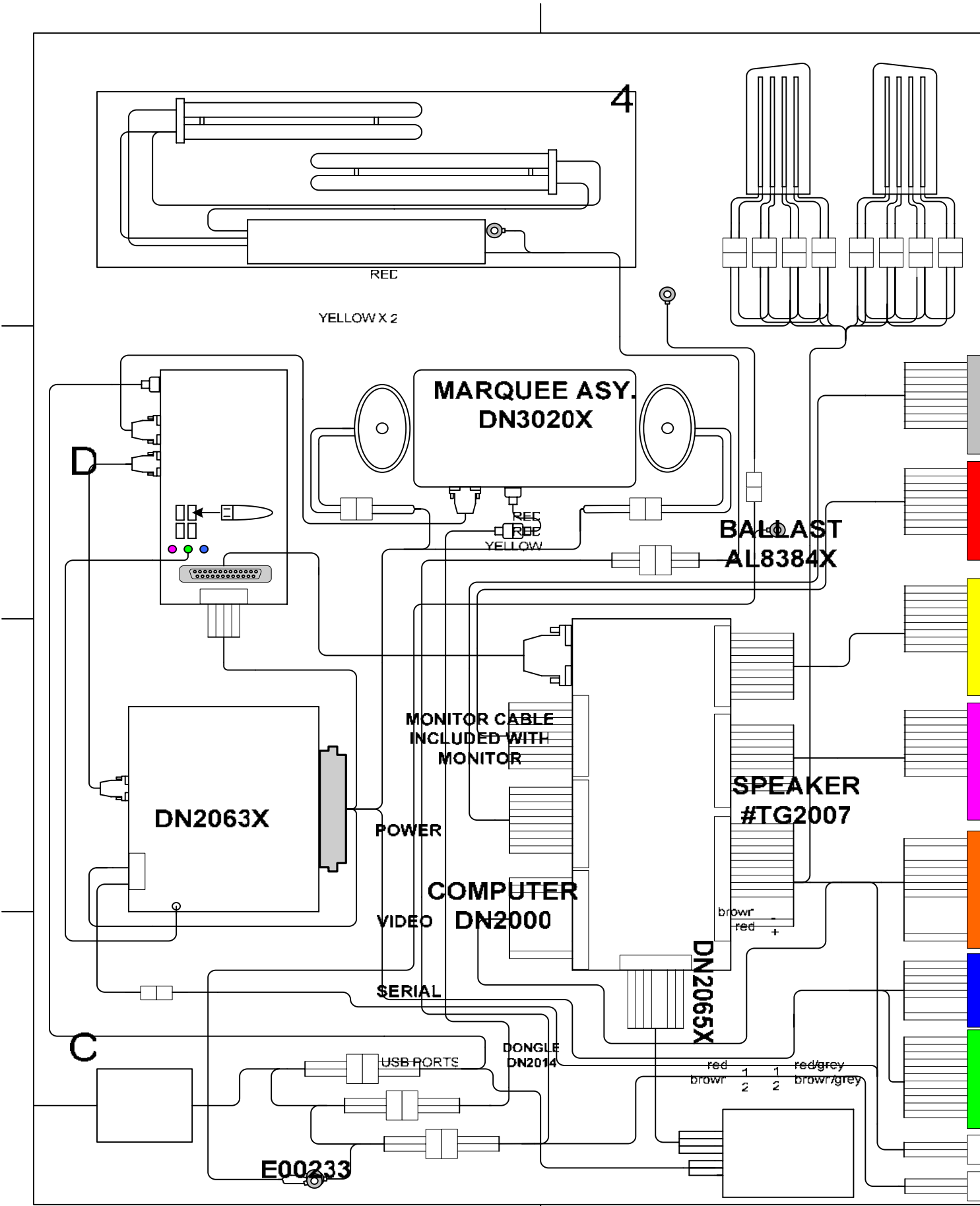

E02247

- 1 ORANGE
- 2 BLACK
- 3 VIOLET
- 4 RED
- 5 BLACK

E00231

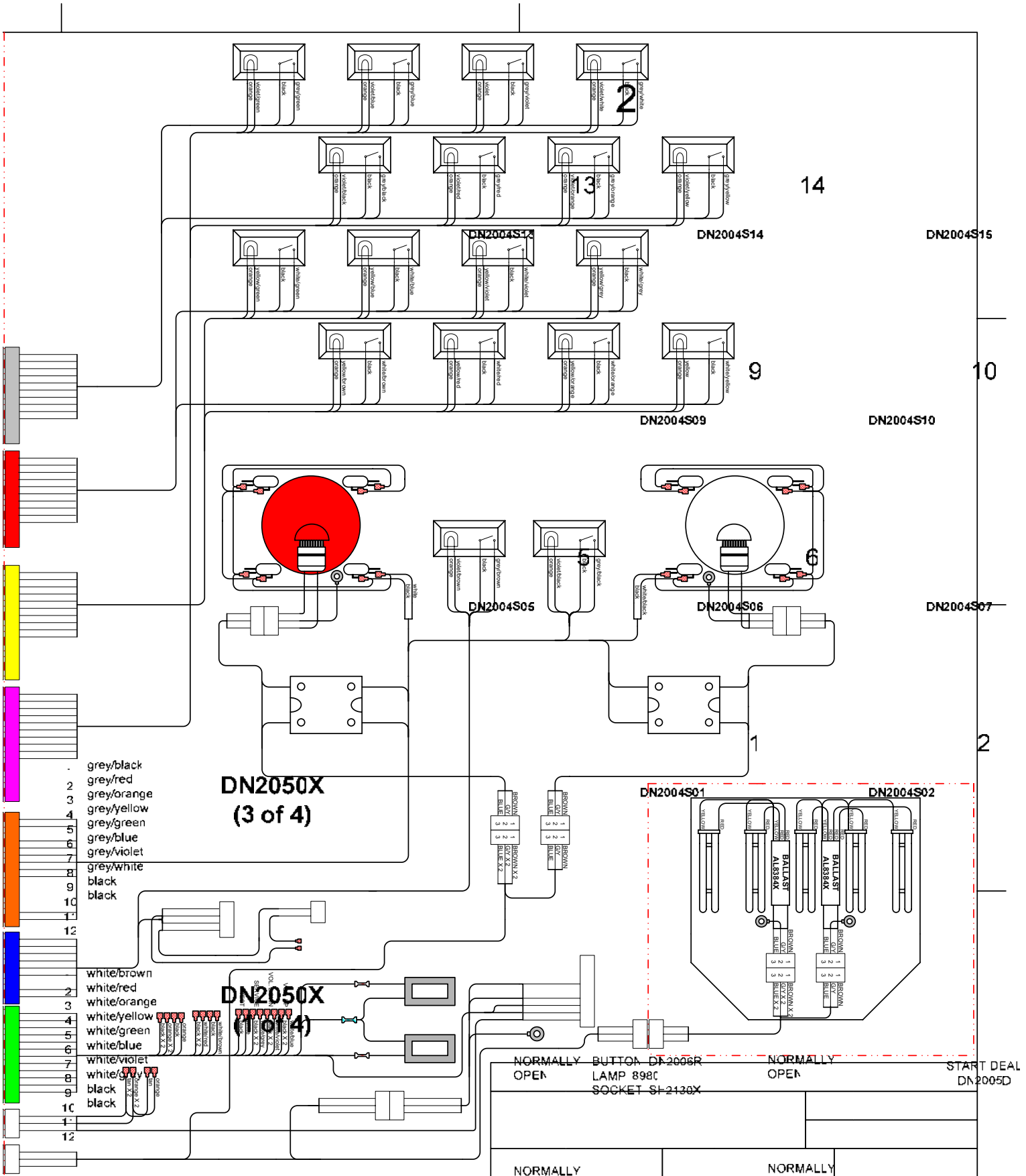

- 1 grey/black
- 2 grey/red
- 3 grey/orange
- 4 grey/yellow
- 5 grey/green
- 6 grey/blue
- 7 grey/violet
- 8 grey/white
- 9 black
- 10 black

- 1 white/brown
- 2 white/red
- 3 white/orange
- 4 white/yellow
- 5 white/green
- 6 white/blue
- 7 white/violet
- 8 white/grey
- 9 black
- 10 black

- 1 yellow/brown
- 2 yellow/red
- 3 yellow/orange
- 4 yellow
- 5 yellow/green
- 6 yellow/blue
- 7 yellow/violet
- 8 yellow/grey
- 9 orange
- 10 orange

**DN2050X  
(3 of 4)**

**DN2050X  
(4 of 4)**

**DN2050X  
(4 of 4)**

25

BROWN	-	BLACK
G/Y	2	G/Y
BLUE	3	WHITE

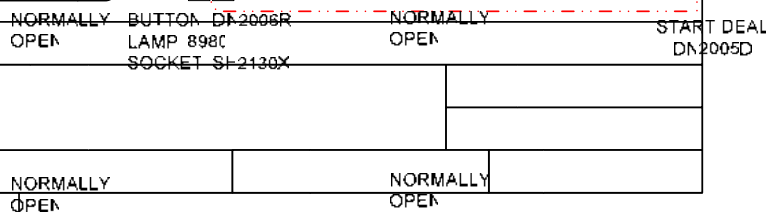

4

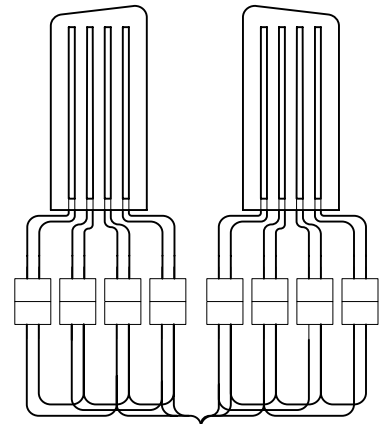
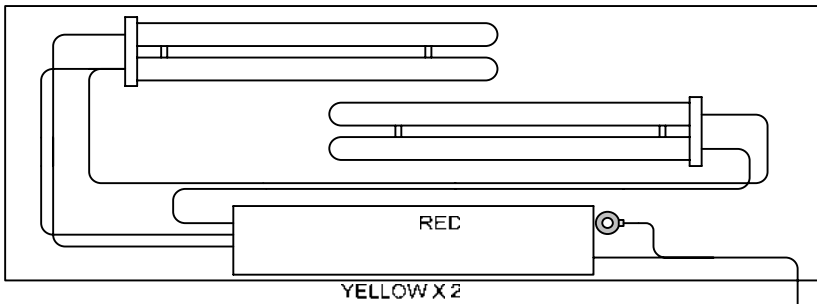

MARQUEE ASY.  
DN3020X

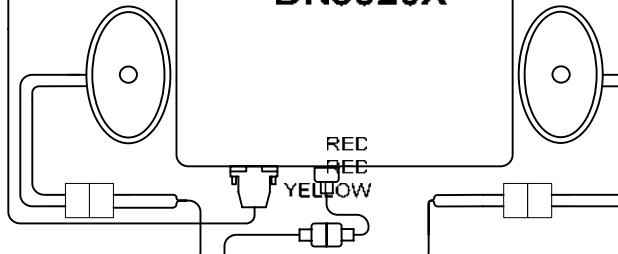

BALLAST  
AL8384X

D

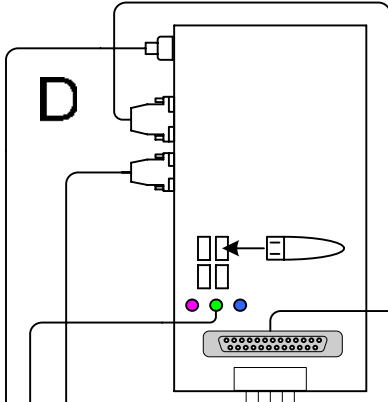

MONITOR CABLE  
INCLUDED WITH  
MONITOR

DN2063X

POWER

COMPUTER  
DN2000

VIDEO

SERIAL

SPEAKER  
#TG2007

DN2065X

brown -  
red +

C

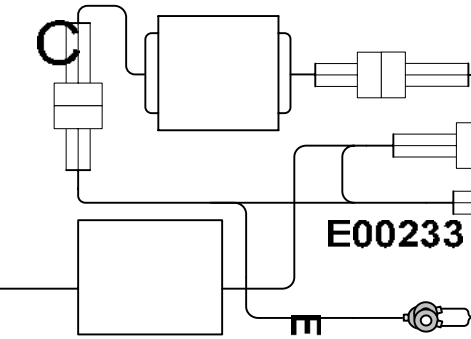

USB PORTS  
DONGLE  
DN2014

1 red/grey  
2 brown/grey

E02247

E00231

220 volt AC

- 1 ORANGE
- 2 BLACK
- 3 VIOLET
- 4 (SHELD)
- 5 BLACK

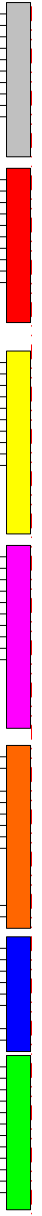

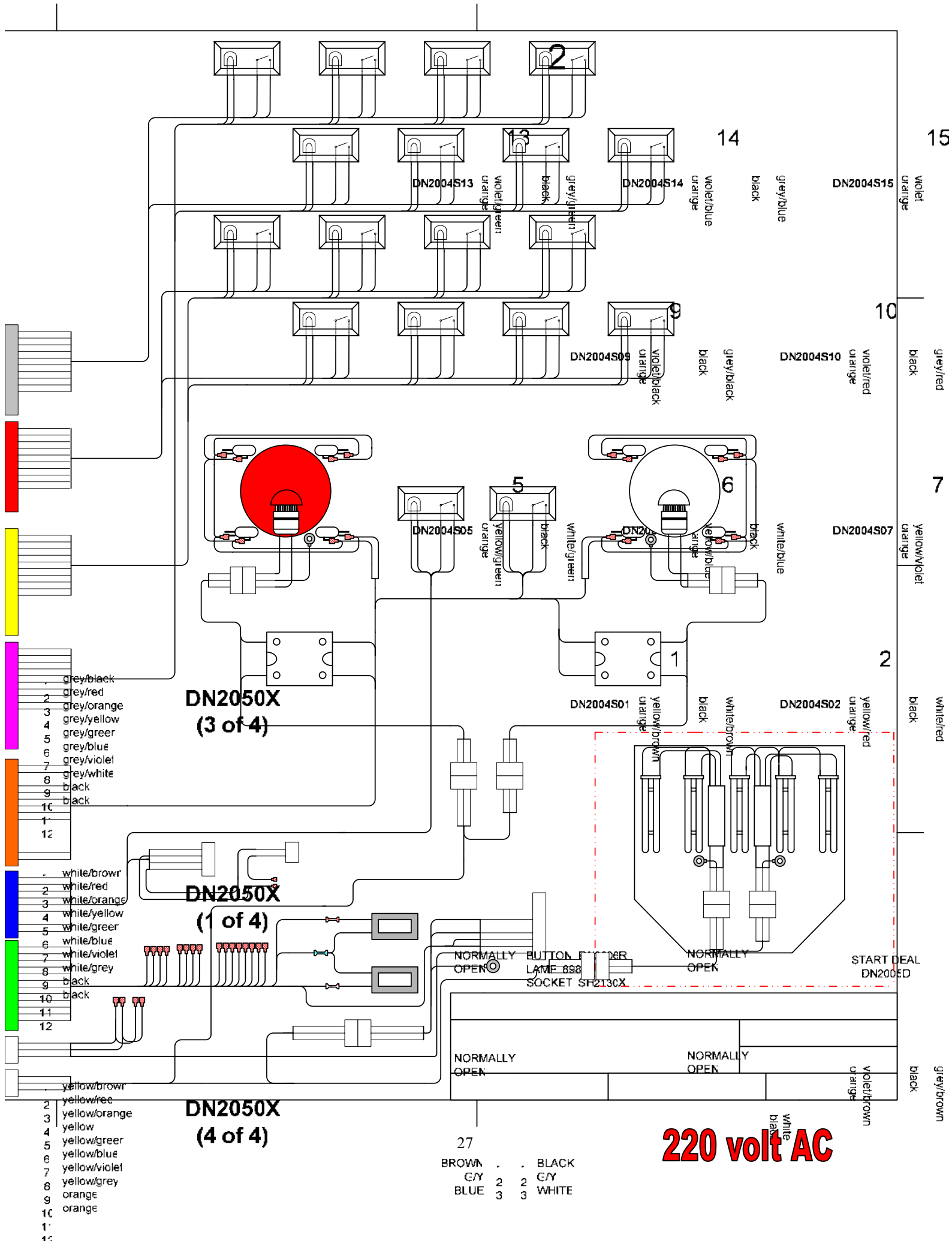

- 1 grey/black
- 2 grey/red
- 3 grey/orange
- 4 grey/yellow
- 5 grey/green
- 6 grey/blue
- 7 grey/violet
- 8 grey/white
- 9 black
- 10 black
- 11
- 12

- 1 white/brown
- 2 white/red
- 3 white/orange
- 4 white/yellow
- 5 white/green
- 6 white/blue
- 7 white/violet
- 8 white/grey
- 9 black
- 10 black
- 11
- 12

- 1 yellow/brown
- 2 yellow/red
- 3 yellow/orange
- 4 yellow
- 5 yellow/green
- 6 yellow/blue
- 7 yellow/violet
- 8 yellow/grey
- 9 orange
- 10 orange
- 11
- 12

27  
 BROWN . . BLACK  
 C/Y 2 2 C/Y  
 BLUE 3 3 WHITE

**220 volt AC**

NORMALLY OPEN    BUTTON LAMP 828    SOCKET SF213CX    NORMALLY OPEN    START DEAL DN200ED

NORMALLY OPEN    NORMALLY OPEN    violet/brown    black    grey/brown

# Spare Parts Listing

## Mechanical

CP1050	DRAWER SLIDE
DN1015	COMPUTER STRAP
DN4001	COMPUTER FOAM PAD
TG4002	Stool

## Electrical

DN8978X	DIP red LED
DN8979X	DIP red LED
DN2000	Computer
DN2014	Dongle
DN2034x	I/O Board (serial)
MON32LCD	32" TFT Monitor
SH2007x	Power Module
TG2007	Polk Speakers
UC2010	Switching Power Supply
DN2035x	I/O Board (parallel)
E00231	Parallel Cable
E02247	Serial Cable
DN2090x	Restore CD
8980	LED Bulb 110VAC (red)
8981	LED Bulb 110VAC (white)
DN2004S01	'Briefcase' #1 Button
DN2004S02	'Briefcase' #2 Button
DN2004S03	'Briefcase' #3 Button
DN2004S04	'Briefcase' #4 Button
DN2004S05	'Briefcase' #5 Button
DN2004S06	'Briefcase' #6 Button
DN2004S07	'Briefcase' #7 Button
DN2004S08	'Briefcase' #8 Button
DN2004S09	'Briefcase' #9 Button
DN2004S10	'Briefcase' #10 Button
DN2004S11	'Briefcase' #11 Button
DN2004S12	'Briefcase' #12 Button
DN2004S13	'Briefcase' #13 Button
DN2004S14	'Briefcase' #14 Button
DN2004S15	'Briefcase' #15 Button
DN2004S16	'Briefcase' #16 Button
HH5005D	Ticket Dispenser
DN2005DD	Yellow "Double Deal" Button
DN2005S	Yellow "Start" Button
DN2006R	Mega Push Button (RED)
DN2006W	Mega Push Button (WHITE)
8312	Bulb (40W)
AL8384x	Ballast (marquee)
CX8384x	Ballast (Stool Base)
PP250x	Bulb Socket

## Graphics

DN7003	Cabinet Front
DN7005	Monitor Bezel
DN7006	Floor Graphic—Yellow

# Warranty

I.C.E warrants all components in the **Deal Or No Deal™** game to be free of defects in materials and workmanship for a period of ninety days from the date of purchase.

This warranty does not cover items damaged due to normal wear and tear, subjected to abuse, improperly assembled by the end user, modified, repaired, or operated in a fashion other than that described in the service manual.

If your **Deal or No Deal™** game fails to conform to the above-mentioned warranty, our sole responsibility shall be at our option to repair or replace any defective component with a new or remanufactured component of equal to or greater O.E.M. specification.

I.C.E. will assume no liability whatsoever, for costs associated with labor to replace defective parts, or travel time associated therein.

Our obligation will be to ship free of charge, replacement parts by U.P.S. Ground, U.S. mail, or other comparable shipping means. Any express mail or overnight shipping expense is at the cost of the purchaser.

Products will be covered under warranty only when:

- The serial number of the game with the defective parts is given. A RMA number has been issued by an I.C.E. technical representative.
- The serial number of the defective part, if applicable, is given..
- A copy of the sales receipt is available as proof of purchase upon request of I.C.E.

I.C.E. distributors are independent, privately owned and operated. In their judgment, they may sell parts or accessories other than those manufactured by I.C.E. We cannot be responsible for the quality, suitability, or safety of any non-I.C.E. part, or any modification, including labor, which is performed by such a distributor.





# WARRANTY

ICE Inc warrants that all of its products will be free from defects in material and workmanship.

When placing a warranty request, please be prepared to provide the following information:

- Serial Number of Game or Bill of Sale
- Machine Type
- A Detailed Description of the Equipment Fault Symptoms

ICE product, including Cromptons, Sam's Billiards, Uniana and Bell Fruit is warranted as follows:

- 180 days on the Main PCB and Computers
- 180 days on Motors
- 90 days on all other components (i.e. DBV's, Ticket Dispensers, etc)
- 30 days on repaired items
- 3 years on all Crane Harnessing
- 9 Months on Printers

ICE Inc shall not be obligated to furnish a warranty request under the following conditions:

- Equipment has been subjected to unwarranted stress through abuse or neglect
- Equipment has been damaged as a result of arbitrary repair/modification attempts
- Equipment that has failed through normal wear and tear

ICE Inc will assume no liability whatsoever for costs associated with labor to replace defective parts or travel time associated therein.

All defective warranty covered components will be replaced with new or factory refurbished components equal to OEM specifications. ICE Inc will cover all UPS ground, or comparable shipping means, freight costs during the warranty period. Expedited shipments are available for an additional charge.

Defective parts are returned to ICE Inc, at the customer's expense, in a timely fashion.

ICE distributors are independent, privately owned and operated. In their judgment, they may sell parts and/or accessories other than those manufactured by ICE Inc. We cannot be responsible for the quality, suitability or safety of any non-ICE part, modification (including labor) that is performed by such a distributor.

I.C.E. Parts/Service Dept.  
Innovative Concepts in Entertainment  
10123 Main St.  
Clarence, NY 14031  
Phone #: (716) - 759 - 0360  
Fax #: (716) - 759 - 0884