



INSTRUCTIONS

-J04431

REV. 2013-06-14

MODULAR BRAKE LINE KITS

GENERAL

For ABS Models:

WARNING

The rider's safety depends upon the correct installation of this kit. Dealer installation is required for vehicles equipped with ABS brakes. Proper installation of this kit requires the use of special tools available only through a Harley-Davidson Dealer. An improperly serviced brake system can adversely affect brake performance, which could result in death or serious injury. (00578b)

NOTE

ABS and NON-ABS models share upper brake line kits, however ABS model installation instructions are found with the ABS Lower Brake Line Kit instructions (-J04652 or -J05790).

For Non-ABS Models:

These instructions describe the installation of upper and lower brake lines on non-ABS Electra Glide®, Street Glide®, Road King®, Road Glide®, Tri Glide™ Ultra Classic® and Street Glide® Trike models ONLY. For installation of the upper brake line on any other model, including ABS, refer to the instruction sheet included in the Lower Brake Line Kit for that model.

For 2014-later Trike Models:

2014-later Trike models and earlier NON-ABS Trike models share upper brake line kits, however 2014-later linked brake model installation instructions are found with the Linked Lower Brake Line and Linked Adapter Kit instructions (-J05690 or -J05691).

Kit Numbers

Table 1. Upper Brake Line Kits (Banjo Angle 0° - Straight)

Diamond-Black Kit	Diamondback Kit	Length
N/A	42393-08	18 inch
N/A	42396-08	19 inch
N/A	42399-08	20 inch
N/A	42428-08	21 inch
41800279A	42439-08A	22 inch
N/A	42461-08	23 inch
N/A	42484-08A	24 inch
N/A	42527-08A	26 inch
41800348	42548-08A	28 inch
N/A	42599-08	30 inch
41800350	44081-09A	32 inch
N/A	46336-09	34 inch
41800281	46566-09	36 inch

Table 2. Upper Brake Line Kits (Banjo Angle 35°)

Diamond-Black Kit	Diamondback Kit	Length
N/A	44106-08	18 inch
N/A	44138-08	19 inch
48940-10	44206-08	20 inch
N/A	44213-08	21 inch
N/A	44250-08A	22 inch
38118-10	44259-08	23 inch
N/A	44306-08A	24 inch
38120-10	44340-08	26 inch
38139-10	44355-08A	28 inch
38141-10	44461-08	30 inch
N/A	40958-09	32 inch
41800282	46711-09	34 inch
N/A	46727-09	36 inch
38143-10	38147-10	40 inch
38145-10	38149-10	44 inch

Table 3. Upper Brake Line Kits (Banjo Angle 90°)

Diamond-Black Kit	Diamondback Kit	Length
48931-10	44790-08	18 inch
48929-10	45007-08	19 inch
N/A	45082-08	20 inch
48944-10	45094-08	21 inch
N/A	45131-08	22 inch
N/A	45134-08	23 inch
N/A	45150-08	24 inch
N/A	45223-08	26 inch
N/A	45251-08	28 inch
N/A	45260-08	30 inch
48995-10	44162-09	32 inch
N/A	46743-09	34 inch
N/A	46747-09	36 inch

NOTE

Diamondback™ and Diamond-Black Upper Brake Line Kits are available in a variety of master cylinder banjo angles and brake line lengths. Shorter or longer lines may be necessary when modifications (i.e., optional handlebars) have been made to the motorcycle. See the P&A retail catalog or a Harley-Davidson dealer for more information.

Table 4. Lower Brake Line Kits

Diamond-Black Kit	Diamondback Kit	Models
41800280	44905-08	2008-2013 Electra Glide® and Street Glide®
48942-10	44907-08	2008-2013 Road King® and Road Glide®
48938-10	45818-07	1994-2007 Road King® and Road Glide®
N/A	45820-07	1996-2007 Electra Glide® and Street Glide®
N/A	83666-10	2008-2013 Street Glide® Trike and Tri Glide™ Ultra Classic®
41800338	41800336	2014-Later Electra Glide®, Street Glide® and Road King®

Models

For model fitment information, see the P&A retail catalog or the Parts and Accessories section of www.harley-davidson.com (English only).

⚠ WARNING

Brakes are a critical safety component. Contact a Harley-Davidson dealer for brake repair or replacement. Improperly serviced brakes can adversely affect brake performance, which could result in death or serious injury. (00054a)

⚠ WARNING

The rider's safety depends upon the correct installation of this kit. Use the appropriate service manual procedures. If the procedure is not within your capabilities or you do not have the correct tools, have a Harley-Davidson dealer perform the installation. Improper installation of this kit could result in death or serious injury. (00333a)

NOTE

This instruction sheet refers to service manual information. A service manual for this year/model motorcycle is required for this installation and is available from a Harley-Davidson dealer.

Additional Parts Required

NOTE

This instruction sheet covers motorcycle models that use either DOT 4 Hydraulic Brake Fluid or DOT 5 Silicone Hydraulic Brake Fluid. The motorcycle's owner's manual, service manual and the master cylinder cover will all indicate which type of brake fluid should be used for this motorcycle.

⚠ CAUTION

Direct contact of D.O.T. 5 brake fluid with eyes can cause eye irritation, swelling, and redness. Avoid eye contact. In case of eye contact flush with large amounts of water and get medical attention. Swallowing large amounts of D.O.T. 5 brake fluid can cause digestive discomfort. If swallowed, obtain medical attention. Use in well ventilated area. KEEP OUT OF REACH OF CHILDREN. (00144a)

⚠ CAUTION

Direct contact of D.O.T. 4 brake fluid with eyes can cause irritation. Avoid eye contact. In case of eye contact flush with large amounts of water and get medical attention. Swallowing large amounts of D.O.T. 4 brake fluid can cause digestive discomfort. If swallowed, obtain medical attention. Use in well ventilated area. KEEP OUT OF REACH OF CHILDREN. (00240a)

Fresh, uncontaminated DOT 4 (H-D Part No. 99953-99A) or DOT 5 brake fluid (H-D Part No. 99902-77) from a sealed container is required. See the service manual.

WARNING

Install proper length brake lines. Incorrect brake line length can adversely affect motorcycle operation, which could cause loss of control resulting in death or serious injury. (00325a)

- If installing different handlebars, measure the change in distance that will be required from the end of the stock brake line to the brake master cylinder.
- Compare this revised length to the brake line provided in your kit.
- If the line is more than 2.0 in (50.8 mm) longer or more than 1.0 in (25.4 mm) shorter than the above measured distance, see a Harley-Davidson dealer for the correct brake line length.

Kit Contents

See Table 6, Table 7, Table 8 and Table 9.

REMOVAL

WARNING

To prevent accidental vehicle start-up, which could cause death or serious injury, remove main fuse before proceeding. (00251b)

1. Refer to the service manual and follow the instructions given to remove the main fuse.

NOTICE

D.O.T. 4 brake fluid will damage painted and body panel surfaces it comes in contact with. Always use caution and protect surfaces from spills whenever brake work is performed. Failure to comply can result in cosmetic damage. (00239b)

NOTE

Immediately wipe up any brake fluid spillage with a clean, dry, soft cloth. Follow up by thoroughly wiping affected area with a clean, damp, soft cloth (small spills) or washing with a large quantity of soapy water (large spills).

2. Drain the brake fluid from the front brake reservoir and lines per the instructions in the service manual.

NOTE

Cover the front fender and the front of the fuel tank with clean shop towels to prevent scratching. Damage to the finish could result.

3. Disconnect the front brake lines following the instructions in the appropriate service manual.

Save the master cylinder banjo bolt, the caliper banjo bolts (for 1994-2007 models), the caliper banjo bleeder bolts (for 2008-later models), the brake line tee attaching screw (for 2008-2013 models) and the hardware mounting the plastic brake line mount bracket at the rear of the lower triple-clamp (for 2014-later models) for later assembly. Discard all sealing washers and the plastic brake line mount bracket (for 2014-later models).

4. Some stock Touring models are equipped with a locating roll pin on the mounting surface for the lower brake line

manifold. Remove the roll pin before installing this brake line kit.

INSTALLATION (2013-EARLIER MODELS)

1. Verify that the correct upper and lower Brake Line Kits have been obtained.
 - In some cases, the Upper Brake Line Kit has already been specified.
 - In other cases, the proper Upper Brake Line Kit (see Table 1, Table 2 or Table 3) needs to be determined using the Cable and Brake Line Measurement Tool Kit. See a Harley-Davidson dealer for assistance.
 - See Table 4 to determine the correct Lower Brake Line Kit for your model motorcycle.

NOTICE

Avoid leakage. Be sure gaskets, banjo bolt(s) and brake line are clean and undamaged before assembly. (00323a)

2. See Figure 1. Obtain the **new** lower brake line assembly (2).

NOTE

The lower brake line manifold tee is mounted so the two lines to the calipers go to the rear and down.

3. Position the brake line tee (3) to the underside of the fork stem, and center the lower legs of the brake line between the forks.
4. Install the brake line tee attaching screw (4) removed earlier and fasten the tee to the fork stem. Tighten the screw to 10-15 ft-lbs (13.6-20.3 Nm).

NOTE

The brake lines must not contact the forks. If either brake line is touching the fork, loosen the brake tee, reposition and re-tighten.

WARNING

Replace brake line gaskets. Re-using original gaskets can cause brake failure and loss of vehicle control, which could result in death or serious injury. (00318a)

5. **For 2008-Later Models:** At each front brake caliper, position a **new** copper gasket from the Lower Brake Line Kit on each side of the brake line banjo fitting. Insert the banjo bleeder bolt (removed earlier) through the washers and fitting. Thread the bolt into the caliper and tighten to 17-19 ft-lb (23.0-25.8 Nm).

For 1994-2007 Models: At each front brake caliper, position a **new** sealing washer (steel/rubber) from the Lower Brake Line Kit on each side of the brake line banjo fitting. Insert the banjo bolt (removed earlier) through the washers and fitting. Thread the bolt into the caliper and tighten to 17-22 ft-lb (23.0-29.8 Nm).

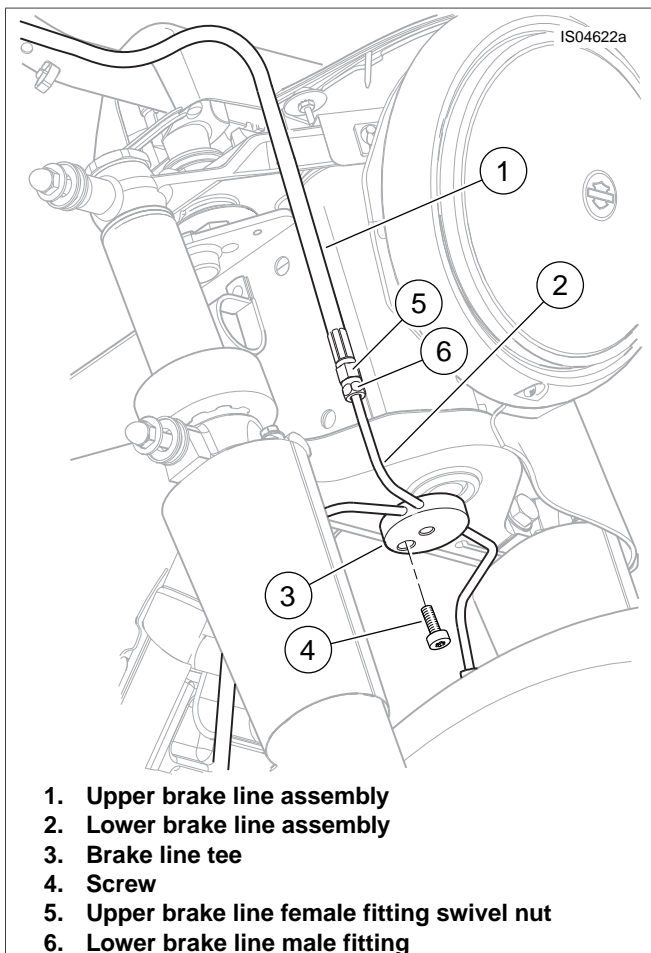

Figure 1. 2013-Earlier Front Brake Lines (Road King Model Shown)

6. Obtain the **new** upper brake line assembly (1). Route the upper brake line from the master cylinder through the fairing or headlamp nacelle area to the male fitting on the upper end of the lower brake line.
7. Install the banjo fitting of the **new** upper brake line at the master cylinder, using a **new** copper gasket from the Upper Brake Line Kit on each side of the fitting.
8. Install the banjo bolt (removed earlier) snug, but do not fully tighten at this time.
9. **For Road King and Road Glide models:** Using cable straps from the Lower Brake Line Kit, tie the brake line to the handlebar riser.

For Electra Glide models: Route the upper brake line the same as the original equipment brake line, along the handlebar between the inner fairing and the inner fairing cap.

For ALL models: Review the routing of the upper brake line from the master cylinder, through the fairing or headlamp nacelle area, to the junction of the upper and lower brake lines.

Verify that the routing of the brake line is smooth and does not interfere with any vehicle components. If necessary, adjust the position of the cable straps.

NOTE

When tightening the fitting, turn only the swivel nut. Do not allow the male fitting or manifold tubing to turn.

10. See Figure 1. Position the upper brake line female fitting swivel nut (5) to the male fitting (6) on the lower brake line. Thread the nut onto the male fitting finger-tight, do not twist the upper or lower brake lines while tightening.
11. See Figure 3. Using two 7/16 inch open-end wrenches, tighten the swivel nut (2) past finger-tight by 45 degrees (1/8 turn) relative to the male fitting (4) or tighten to 45-65 **in-lbs** (5.1-7.3 Nm).

INSTALLATION (2014-LATER MODELS)

1. Verify that the correct upper and lower Brake Line Kits have been purchased.
 - In some cases, the Upper Brake Line Kit has already been specified.
 - In other cases, the proper Upper Brake Line Kit (see Table 1, Table 2 or Table 3) needs to be determined using the Cable and Brake Line Measurement Tool Kit. See a Harley-Davidson dealer for assistance.
 - See Table 4 to determine the correct Lower Brake Line Kit for your model motorcycle.

NOTICE

Avoid leakage. Be sure gaskets, banjo bolt(s) and brake line are clean and undamaged before assembly. (00323a)

2. See Figure 2. Obtain the new upper (1) and lower (2) brake line assemblies.

NOTE

The lower brake line manifold is mounted so the two lines to the calipers go to the rear and down.

3. Position the lower brake line (2) to the backside of the lower triple clamp, and center the lower legs of the brake line between the forks oriented rearward and down.
4. Obtain the large (6) and small (7) brake line P-clamps and attachment screws removed earlier from the plastic brake line mount bracket. Attach the lower brake line assembly and fasten the P-clamps to the triple clamp. The right hand p-clamps will overlap. Tighten the screw to 10-15 ft-lbs (13.6-20.3 Nm).

NOTE

The brake lines must not contact the forks. If either brake line is touching the fork, loosen the p-clamps, reposition and re-tighten.

WARNING

Replace brake line gaskets. Re-using original gaskets can cause brake failure and loss of vehicle control, which could result in death or serious injury. (00318a)

5. At each front brake caliper (4) position a new copper gasket from the Lower Brake Line Kit on each side of the brake line banjo fitting. Insert the banjo bleeder bolt (removed earlier) through the gaskets and banjo fitting.
6. Orient the banjo fitting against the rotation stop on the caliper and thread the bolt into the caliper. Tighten to 17-19 ft-lb (23.0-25.8 Nm).
7. Route the upper portion of the brake line (1) from the master cylinder (3) through the fairing or headlamp nacelle

area to the male fitting on the upper end of the lower brake line (5).

8. Install the banjo fitting of the **new** upper brake line at the master cylinder, using new copper gaskets from the Upper Brake Line Kit on each side of the fitting.
9. Install the banjo bolt (removed earlier) snug, but do not fully tighten at this time.

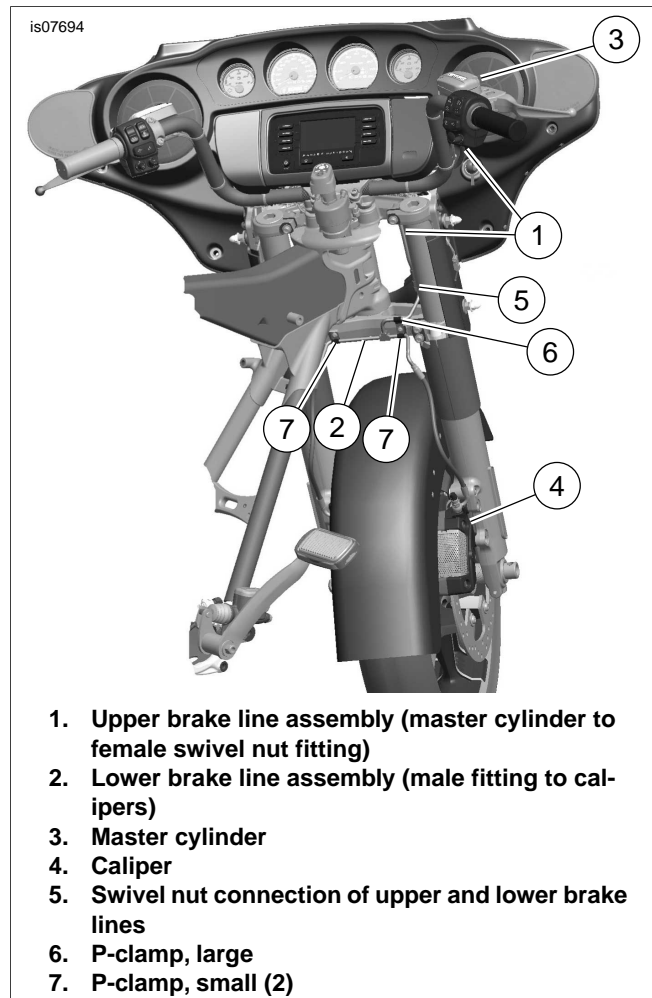

Figure 2. 2014-Later Front Non-ABS Brake Lines

10. **For Road King models:** Route the upper brake line the same as the original equipment brake line along the handlebar to fit under the riser cover into the headlamp nacelle and secure as needed using cable straps from the Upper Brake Line Kit.

For Electra Glide models: Route the upper brake line the same as the original equipment brake line, along the handlebar between the inner fairing and the inner fairing cap and secure as needed using cable straps from the Upper Brake Line Kit.

For ALL models: Review the routing of the upper brake line from the master cylinder, through the fairing or head lamp nacelle area, to the junction of the upper and lower brake lines.

Verify that the routing of the brake line is smooth and does not interfere with any vehicle components. If necessary, adjust the position of the cable straps.

11. See Figure 3. Position the upper brake line female fitting swivel nut (2) to the male fitting (4) on the lower brake line.

Thread the nut onto the male fitting finger-tight. Do not twist the upper or lower brake lines while tightening.

12. Using two 7/16 inch open-end wrenches, tighten the swivel nut (2) past finger tight by 45 degrees (1/8 turn) relative to the male fitting (4) or torque to 45-65 **in-lbs** (5.1-7.3 Nm).

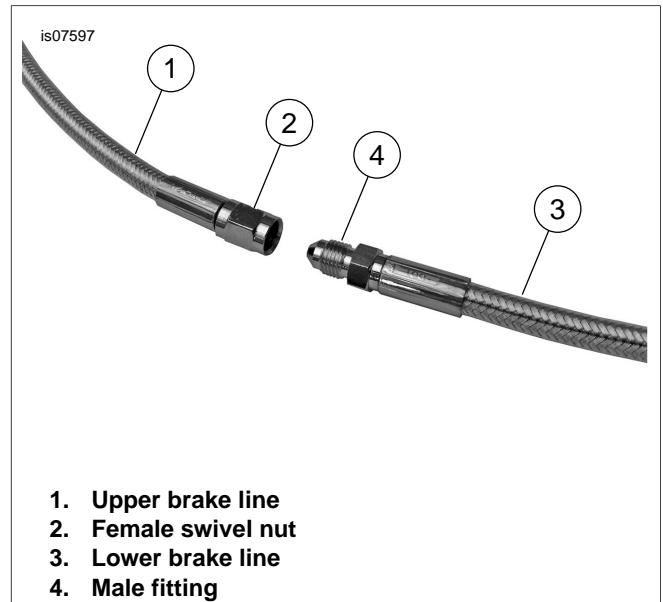

Figure 3. Upper to Lower Brake Line Fittings

BRAKE LINE ROUTING CHECK

1. Using a motorcycle lift, raise the vehicle frame so that the front forks reach maximum extension. Verify that the lower brake lines are not pulled tight when forks are fully extended.
2. Fully compress the forks to check that the lower brake lines do not interfere with motorcycle components.
3. Turn the handlebars to the full-left and full-right fork stops to verify smooth routing and proper slack in the brake lines, and to verify the brake lines do not contact any vehicle components.
4. Adjust the brake lines and/or banjo fitting orientation if the brake lines interfere or catch on motorcycle components, or if the routing does not appear correct.

See Table 5. When all adjustments are complete, tighten the master cylinder banjo bolt to specification.

Table 5. Banjo Bolt Torque Values

Models	Master Cylinder Banjo Bolt Torque
1994-2007 Models	17-22 ft-lbs (23.0-29.8 Nm)
2008-Later Models	12.5-14.5 ft-lbs (17-20 Nm)

FINAL ASSEMBLY

NOTE

This instruction sheet covers motorcycle models that use either DOT 4 Hydraulic Brake Fluid or DOT 5 Silicone Hydraulic Brake Fluid. The specific model's owner's manual, service manual

and the master cylinder cover will all indicate which type of brake fluid should be used for this motorcycle.

⚠ WARNING

Clean filler cap before removing. Use only D.O.T. 4 brake fluid from a sealed container. Contaminated fluid can adversely affect braking, which could result in death or serious injury. (00504c)

NOTES

Do not mix grades of brake fluid as they are not compatible.

Immediately wipe up any brake fluid spillage with a clean, dry, soft cloth. Follow up by thoroughly wiping affected area with a clean, damp, soft cloth (small spills) or washing with a large quantity of soapy water (large spills).

Cover nearby motorcycle surfaces to help protect against damage to finish caused by spillage or splash of DOT 4 brake fluid.

1. Add the appropriate brake fluid to the master cylinder reservoir following the instructions in the service manual. Do not reuse old brake fluid. Only use fluid from a sealed container.

⚠ WARNING

Be sure the master cylinder relief port is not plugged. A plugged relief port can cause brake drag or lockup and loss of vehicle control, which could result in death or serious injury. (00317a)

2. Verify proper operation of the master cylinder relief port. Actuate the brake hand lever. A slight spurt of fluid will break the fluid surface in the reservoir compartment if all internal components are working properly.
3. Bleed the brake system following the instructions in the appropriate service manual.

NOTE

Before installing the master cylinder cover, verify that the cover gasket bellows is not expanded. If bellows is expanded, brake fluid will be ejected from the reservoir during cover installation, which could damage the vehicle finish.

4. Note that the shape of the master cylinder cover has one end thinner than the other.

For 2008 Models: Install the cover (with gasket compressed) on the master cylinder reservoir so the thinner end is positioned above the brake line fitting.

For 1994-2007 Models: Install the cover (with gasket compressed) on the master cylinder reservoir so the thicker end is positioned above the brake line fitting.

For All Models: Install two screws to fasten the cover to the reservoir. Tighten the screws to 6-8 **in-lb** (0.7-0.9 Nm).

5. Verify that the ignition key switch is turned to the OFF position.
6. Refer to the service manual and follow the instructions to install the main fuse or connect the battery cable.

7. Turn the ignition key switch to IGNITION, but do not start the motorcycle. Actuate the front brake hand lever to verify operation of the brake lamp.
8. Install any other removed components following the instructions in the service manual.

⚠ WARNING

After repairing the brake system, test brakes at low speed. If brakes are not operating properly, testing at high speeds can cause loss of control, which could result in death or serious injury. (00289a)

9. Test ride the motorcycle. If the brake feels spongy, repeat the bleeding procedure.

SERVICE PARTS

Table 6. Service Parts, Upper Brake Line Kits - Purchase Separately

Item	Description (Quantity)	Part Number
1	Brake line assembly, upper	Not sold separately
2	Copper gasket, brake line (2)	41751-06A
3	Cable strap (3)	10006

Table 7. Service Parts, Lower Brake Line Kits 44905-08, 44907-08, 48942-10, 83666-10 and 41800280

Item	Description (Quantity)	Part Number
1	Brake line assembly, lower	Not sold separately
2	Copper gasket, brake line (4)	41751-06A
3	Cable strap (3)	10006

Table 8. Service Parts, Lower Brake Line Kits 45818-07, 45820-07 and 48938-10

Item	Description (Quantity)	Part Number
1	Brake line assembly, lower	Not sold separately
2	Sealing washer (4)	41731-01
3	Cable strap (3)	10006

Table 9. Service Parts, Lower Brake Line Kits 41800336 and 41800338

Item	Description (Quantity)	Part Number
1	Brake line assembly, lower	Not sold separately
2	Copper gasket (4)	41751-06A
3	P-clip, large	Not Sold Separately
4	P-clip, small (2)	Not Sold Separately
5	Cable strap (3)	10006