

# User Manual

# Armadillo 10X Series

Models: Gasoline, LP & Diesel



**PREFACE**

Thank you for your purchase of the now industry standard for sweepers. PowerBoss takes great pride in offering the most dependable, reliable and best value in industrial power sweepers and sweeper / scrubbers. We set the standard.

Our Publishing Department would like to hear from you. If you see any errors, omissions or something that needs clarification in this Spare Parts Catalog please let us know. We are working hard toward perfection in our corner of the process to bring you the best you can buy. Please copy the form below, fill out and comment on how you found our catalog.

Thank you.

\*Name \_\_\_\_\_

\*Title: \_\_\_\_\_

\*Company Name: \_\_\_\_\_

\*Address: \_\_\_\_\_

\*Country: \_\_\_\_\_

Type of equipment or model number: \_\_\_\_\_

Comments:

\*Information is optional.

Please return to:

Manager, Publishing Department, International  
PowerBoss, Inc.  
175 Anderson Street  
Aberdeen, North Carolina 28315 USA

Phone (800) 982-7141 Toll Free

(910) 944-2105 Local

E-Mail - techsupport@powerboss.com

This is the Spare Parts Catalog for the PowerBoss Armadillo SW/10X Sweeper. This catalog covers all Standard Armadillo 10X machine variations beginning May 2009. We believe this machine will provide excellent service for many years.

However, the best results will be obtained if:

- The machine is operated with reasonable care.
- The machine is maintained regularly per the maintenance schedule provided in the User Manual.
- The machine is maintained with PowerBoss Inc. supplied or equivalent parts.

All right side and left side references to the machine (except for engine) are determined by facing the direction of forward travel. The front of the engine or engine fan faces the rear of the machine. Some hardware considered to be common or locally available has been omitted from the parts section to make this manual clear. Be sure to use equivalent hardware when replacement becomes necessary.

The Model and Serial Number of your machine is shown on the I.D. name plate. This information is needed when contacting Technical Support or when ordering parts. The I.D. plate is mounted on the console of the machine left of the operator. Adjacent the main broom adjustment access door.

Example I.D Plate;

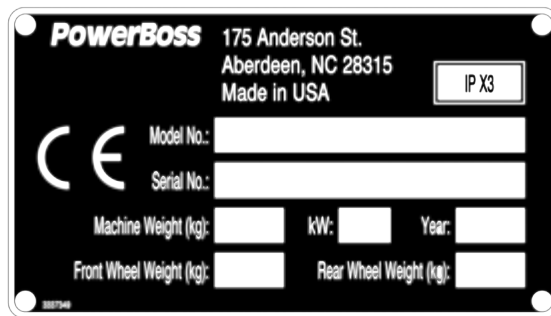

Parts may be ordered by phone, fax or e-mail from any PowerBoss parts and service center. Before ordering parts or supplies, be sure to have your machine model number and serial number handy. For your convenience Fill out the data block below for future reference.

<b>MACHINE DATA</b>	
Fill out at installation	
Serial Number:	_____
Engine Serial Number:	_____
Sales Rep.:	_____
Date of Install:	_____

All information contained in this catalog is current at the time of printing However, PowerBoss reserves the right to make changes at any time without notice.

©2011, PowerBoss, Inc., Printed in USA

**TECHNICAL SPECIFICATIONS**

Model Armadillo 10X  
 Model No.  
 Tier III Models 10XT3DSL / 10XT3LP / 10XT3GAS  
 Other Models 3350500 / 10XLP / 3350400

**DIMENSIONS & WEIGHT**

Length . . . . .105 inch (266.7 cm)  
 width . . . . .68 inch (172.7 cm)  
 height . . . . .55.38 inch (  
 w/ overhead guard . . . . .81 inch (205.7 cm)  
 w/ cab . . . . .81 inch (205.7 cm)  
 weight . . . . .4,575 lbs. (2,075 kg)  
 minimum u-turn . . . . .115 inch (292 cm)

**SWEEPING SYSTEM**

productivity . . . . .217,800 ft<sup>2</sup>/hr (20,234 m<sup>2</sup>/hr)  
 sweep path . . . . .74 inch (187.9 cm)  
 main broom . . . . .56 inch (142 cm)  
 side broom . . . . .26 inch (66 cm)  
 Left side broom optional . . . . .86 inch (218.4 cm)  
 hopper type . . . . .RTR high dump  
 hopper volume . . . . .30 cu ft  
 hopper load capacity . . . . .2,000 lbs (907 kg)  
 dust control . . . . .180 ft<sup>2</sup> (16.7 m<sup>2</sup>)  
 high dump . . . . .64 inch (162.6 cm)  
 RTR  
 (rotary trash relocation) . . . . .yes

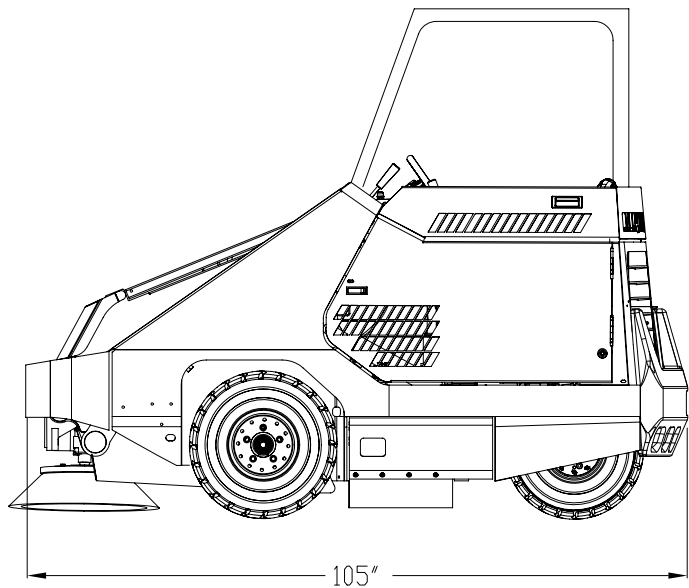
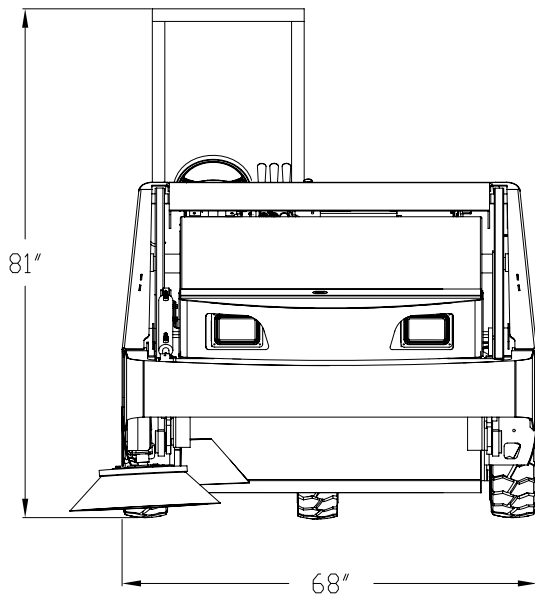

# PowerBoss®

The Power of Clean

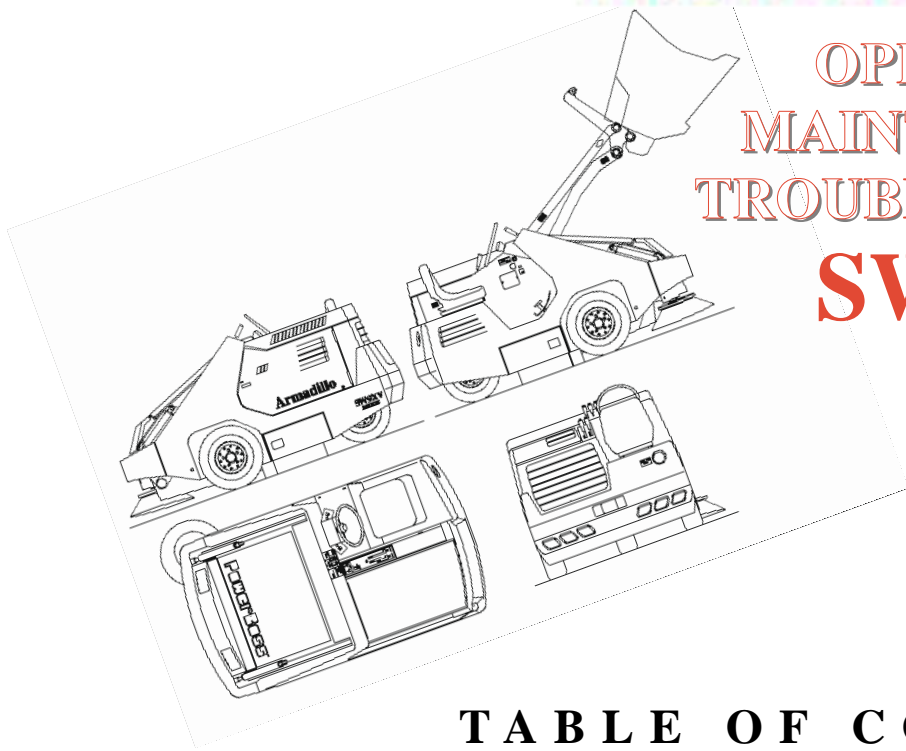

## OPERATION, MAINTENANCE & TROUBLESHOOTING SW/10XV

### TABLE OF CONTENTS

Features .....	7
Limited Warranty .....	8
<b>SAFETY</b>	
Safety Symbols .....	9
Safety Decals .....	10-11
Basic PowerBoss® Safety .....	12-14
<b>OPERATION</b>	
Basic Operating Controls .....	15-16
Sweeping Controls .....	17
Debris Hopper Dump Controls .....	18
<b>Operating Procedures</b>	
Pre-Operation Check .....	19
Starting .....	19
Slowing and Stopping .....	20
Operating on Grades .....	20
Sweeping .....	20
Emptying the Hopper .....	20
Using the Rotary Trash Relocator (RTR™) .....	21
Transporting the Machine .....	22

**TABLE OF CONTENTS (Continued)**

**MAINTENANCE**

Introduction..... 23

**Planned Maintenance Chart**

Engine ..... 24  
 Air Intake System ..... 24  
 Electrical System ..... 24  
 Coolant System ..... 24  
 Hydraulics System..... 25  
 Sweep Components ..... 25  
 Hopper..... 26  
 Steering ..... 26  
 Parking Brake ..... 26  
 Tires ..... 27  
 Miscellaneous ..... 27  
 Impeller ..... 27

**Service Instructions**

Engine ..... 28  
 Air Intake  
     Filter Removal..... 29  
     Filter Cleaning ..... 29  
     Filter Inspection ..... 29  
     Filter Installation..... 29  
 Electrical System  
     Battery Cleaning ..... 30  
     Battery Replacement..... 30  
     Circuit Breakers..... 30  
     Fuses ..... 30  
 Fuel System  
     **WARNINGS**..... 31  
     Tier II Compliance ..... 31  
 Coolant System  
     Blowing Out Radiator Fins ..... 32  
     Reverse Flow Flushing..... 33  
 Lubrication  
     Changing Engine Oil ..... 33  
     Lubrication Points..... 34  
 Hydraulics System  
     Filling the Fluid Reservoir ..... 35  
     Changing the Hydraulic Fluid ..... 35  
     Changing the Hydraulic Fluid Filter ..... 36  
     Adjusting the Directional Control  
     Return Spring ..... 36-37

**TABLE OF CONTENTS (Continued)**

**MAINTENANCE (CONTINUED)**

Sweep Components

Broom Door Flap Inspection ..... 38  
Broom Door Flap Replacement  
and Adjustment ..... 38  
Main Broom Adjustment..... 38  
Main Broom Height Adjustment ..... 39  
Main Broom Taper Adjustment..... 40  
Main Broom Replacement..... 41  
Side Broom Angle Adjustment ..... 42  
Side Broom Height (Wear) Adjustment..... 42  
Side Broom Replacement..... 43

Hopper

Hopper Removal ..... 44  
Hopper Replacement..... 44  
Filter Removal..... 45  
Filter Cleaning ..... 45  
Filter Replacement ..... 45  
Floor Clearance and Dump Adjustments ..... 46  
Adjusting Maximum Hopper Dump Angle ..... 47  
Vacuum Gasket Mount Adjustment ..... 47  
Flap Replacement..... 48  
Frame Seal Replacement  
    Front Frame Seal..... 48  
    Side Frame Seal ..... 48

Parking Brake ..... 49

Tires

Changing Solid Tires ..... 50  
Changing Pneumatic Tires ..... 50

Miscellaneous Adjustments

Anti-Static Chain ..... 51  
Latches and Hinges ..... 51  
Cables ..... 51

## **TABLE OF CONTENTS (Continued)**

### **TROUBLESHOOTING**

#### **Basic Machine Operating Problems**

Engine will not start or runs roughly after start .....	52
Engine overheats .....	53
PowerBoss® moves slowly or does not move .....	53
PowerBoss® creeps in neutral .....	54

#### **Sweeping Problems**

Brushes do not turn or turn very slowly .....	54
Little or no vacuum in brush compartment.....	55
Loss of dust control .....	55
Sweeper unit leaving debris .....	55-56
Hopper does not raise or lower .....	56
Hopper does not rotate or rotates slowly .....	57

#### **Hydraulic System Problems**

Hopper lift cylinder failure .....	57
Hydraulic motor failure .....	58
Hydraulic gear pump failure .....	58
Hydraulic variable displacement pump failure .....	59
Hydraulic system noisy.....	60

Your page .....	61
-----------------	----

Notes .....	62
-------------	----

Electrical Schematic Kubota V2203.....	63
----------------------------------------	----

Electrical Schematic GM 1.6L .....	64
------------------------------------	----

Blank .....	65
-------------	----

Hydraulic Schematic 10XV.....	66
-------------------------------	----

Warranty Matrix .....	67
-----------------------	----



## **SW/10XV**

### **FEATURES**

1. Dust Control Filter: 180 Sq. Ft. total
2. Timed Electric Filter Shakers
3. Shock-mounted Hydraulic Impeller
4. Power Steering with Tilt Steering Wheel
5. Adjustable Seat
6. Exhaust Air Expelled Outside Engine
7. Industrial Liquid-Cooled Engine
8. 4-Core Radiator
9. Tri-Phase Air Cleaner
10. Built-In Dust PreFiltering
11. One-Piece Unitized Steel Frame
12. Clogged Filter Indicator
13. Hydraulics Protection Package
14. Dual Performance Sweep Mode
15. Quick-Change Floating 56" Main Broom
16. PowerClimb™ All-Terrain Access  
(Two 23" OD Pneumatic Front Tires & One 21" OD Pneumatic Rear Tire)
17. Oversized Hopper with RTR™
18. Retractable Quick-Change Side Broom
19. Multi-Level Hopper Dumping Up To 64.0"
20. Fire-in-hopper Indicator

Revision G  
Effective September 2010  
PowerBoss Made Simple Industrial Limited Warranty

Minuteman International owner of PowerBoss warrants to the original purchaser/user that the product is free from defects in workmanship and materials under normal use. PowerBoss will, at its option, repair or replace without charge, parts that fail under normal use and service when operated and maintained in accordance with the applicable operation and instruction manuals. All warranty claims must be submitted through and approved by factory authorized repair stations.

This warranty does not apply to normal wear, or to items whose life is dependent on their use and care. Parts not manufactured by PowerBoss are covered by and subject to the warranties and/or guarantees of their manufacturers. Please contact Minuteman International for procedures in warranty claims against these manufacturers.

**Special warning to purchaser** -- Use of replacement parts not manufactured by PowerBoss or its designated licensees, will void all warranties expressed or implied. A potential health hazard exists without original equipment replacement.

All warranted items become the sole property of Minuteman International or PowerBoss or its original manufacturer, whichever the case may be.

PowerBoss disclaims any implied warranty, including the warranty of merchantability and the warranty of fitness for a particular purpose. PowerBoss assumes no responsibility for any special, incidental or consequential damages.

This limited warranty is applicable only in the U.S.A. and Canada, and is extended only to the original user/purchaser of this product. Customers outside the U.S.A. and Canada should contact their local distributor for export warranty policies. PowerBoss is not responsible for costs or repairs performed by persons other than those specifically authorized by PowerBoss. This warranty does not apply to damage from transportation, alterations by unauthorized persons, misuse or abuse of the equipment, use of non-compatible chemicals, or damage to property, or loss of income due to malfunctions of the product. If a difficulty develops with this machine, you should contact the dealer from whom it was purchased.

This warranty gives you specific legal rights, and you may have other rights, which vary from state to state. Some states do not allow the exclusion or limitation of special, incidental or consequential damages, or limitations on how long an implied warranty lasts, so the above exclusions and limitations may not apply to you.

	Travel*	Labor	Parts	Engine	Extended Warranty	Costs
<b>Walk behinds</b>						
Battery sweepers	Ninety days	One year	One year	N/A	2 years Parts + Labor (or 2000 Hours)	2%
IC sweepers	Ninety days	One year	One year	Through manufacturer	2 years Parts + Labor (or 2000 Hours)	2%
Battery scrubbers	Ninety days	Two years	Three years	N/A	3 Years Parts + Labor (or 3000 Hours)	2%
<b>Riders</b>						
Battery scrubbers	Ninety days	Two years	Three years/2000 hrs	N/A	3 Years Parts + Labor (or 3000 Hours)	2%
IC sweeper/scrubbers	Ninety days	Six months	Two years/2000 hrs	Two years/3000 hrs**	2 years Parts + Labor (or 2000 Hours)	3%
IC sweepers	Ninety days	Six months	Four years/3000 hrs	Five years/3000 hrs**	4 Years Parts + 2 Years Labor (or 4000 Hours)	3%
<b>Exceptions</b>						
Apex series sweeper	Ninety days	One year	One year/1000 hrs	One year/1000 hrs**	2 years Parts + Labor (or 2000 Hours)	3%
6X sweeper	Ninety days	Six months	Two years/2000 hrs	Two years/2000 hours**	2 years Parts + Labor (or 2000 Hours)	3%
<b>Other Products</b>						
QRE-3001A	Ninety days	Six months	Two years/2000 hrs	Two years/3000 hours**	2 years Parts + Labor (or 2000 Hours)	3%

**Tank Bladders** Eight years/ no additional labor  
**Polyethylene plastic tanks** Ten years/ no additional labor  
**Batteries** 0-3 months full replacement, 4-12 prorated credit  
**Chargers** One-year replacement  
**Replacement parts** Ninety days  
**\*Two-hour cap**

\*\*Through engine manufacturer. See section 3 of warranty manual for engine warranty exceptions

\*\*\* Based upon dealer's certification status

Extended Warranty MUST be signed up within 30 days of delivery to End User (Dealer has 1Year from Receiving Machine to Sign up extended Warranty)

Extended Warranty Cost is based on Invoice Price multiplied by the Percentage listed in the Extended Warranty Column

*All above labor and travel reimbursed at 65 or 75% of the published shop rate.*

## SAFETY SYMBOLS

Five symbols are used throughout this manual to emphasize various levels of safety information. These symbols and the meaning of each are listed below.



**DANGER:** To warn of immediate hazards which will result in severe personal injury or death



**WARNING:** To warn of hazards or unsafe practices which could result in severe personal injury or death.



**CAUTION:** To warn of hazards or unsafe practices which could result in minor personal injury.



**ATTENTION!:** To warn of practices which could result in extensive equipment damage.



**NOTE:** To direct your attention to important equipment information or special instructions for preventing damage to equipment

Symbols at the top of the list are the strongest warnings. However, all symbols represent important information which should be observed to protect you and others from harm and injury, and to prevent damage to the equipment.

## SAFETY DECALS

Decals directly attached to various parts of the sweeper are highly visible safety reminders which should be read and observed. Make sure the decals are replaced if they become illegible or damaged. The decal below is located in the drive compartment. Other safety decals on your machine appear on the next page.

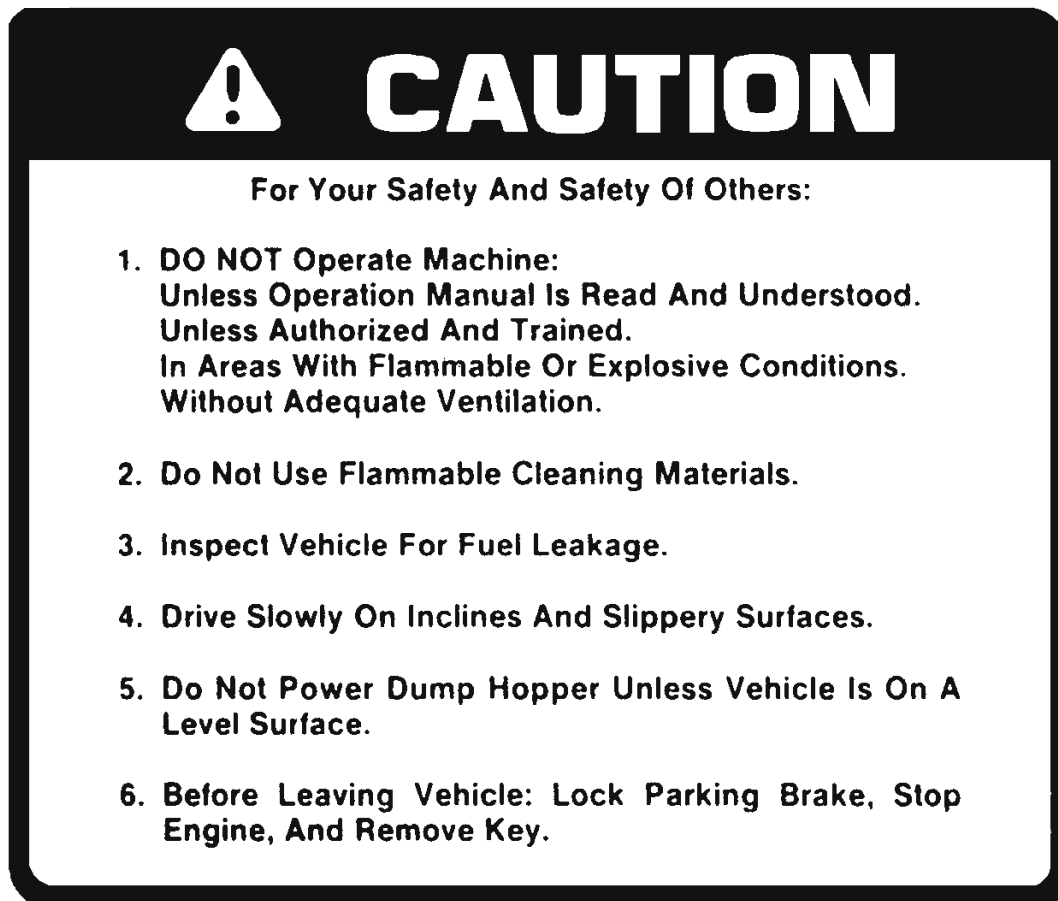

Part Number 301854

## SAFETY DECALS (Continued)

Located at the Impeller:

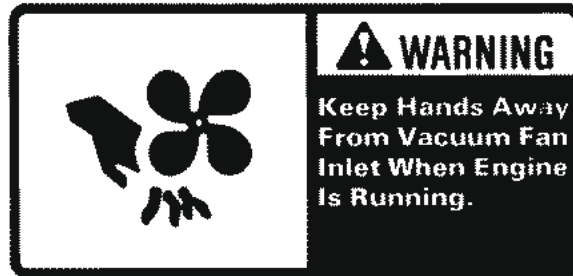

Part Number 301729

Located on the High Dump Hopper:



Part Number 301732

Located on the Shroud of the Radiator:



Part Number 301733

## BASIC PowerBoss<sup>®</sup> SAFETY

PowerBoss<sup>®</sup> sweepers should never be operated unless: 1. The operator is trained and authorized to operate the equipment and, 2. The equipment is free of malfunctions. Malfunctioning equipment should be removed from service.



1. *Keep cigarettes, matches and all other flame sources away from the sweeper. Gasoline, LP gas and diesel fuel are highly flammable. Lead acid batteries are equally dangerous due to the highly explosive hydrogen gas they emit.*



1. *Before starting the engine, make sure that:*
  - \* *You are securely seated in the operator's seat.*
  - \* *The parking brake is locked.*
  - \* *The directional control pedal is in neutral.*
  - \* *The throttle is in idle.*
  - \* *Hydraulic controls are in the OFF position.*
2. *During operation:*
  - \* *Keep your hands and body clear of moving parts, especially when the hopper or lift arms are partially or fully raised.*
  - \* *Make sure others in the area stay clear of the equipment and moving parts.*
  - \* *Never attempt to dump debris from a dock or mezzanine. Dump from ground level only.*
3. *When leaving the sweeper unattended:*
  - \* *Place the controls in the OFF position.*
  - \* *Set the parking brake.*
  - \* *Shut off the engine.*

## BASIC PowerBoss® SAFETY (Continued)

### 4. *During cleaning and maintenance:*

- \* *Always stop the engine and set the parking brake before servicing.*
- \* *Never use detergents or cleansers that are flammable or combustible.*
- \* *Never inflate a pneumatic tire without using a safety cage.*
- \* *Do not attempt any impeller adjustment unless you have shut off the engine. Never place your hands near the intake hoses or inlet when the engine is running.*
- \* *Always engage the safety arm before servicing the hopper. Do not rely on the hydraulic cylinder to keep the hopper raised.*
- \* *Never test for hydraulic hose leaks using your hand or any other part of your body. High pressure leaks can be very dangerous and should only be checked using a piece of paper.*

### 5. *When servicing or repairing the fuel system:*

- \* *Work in a properly ventilated area, do not smoke or allow an open flame near the fuel system.*
- \* *Never bypass safety components unless you are testing them.*
- \* *Never bypass the fuel filter lock, except when testing them (and always reconnect them after testing).*
- \* *Wear gloves to disconnect the tank coupling.*

### 6. *Do not operate an LPG powered sweeper when any component in the fuel system is malfunctioning or leaking.*

### 7. *Replace any defective safety components before operating the sweeper.*



1. *Do not drive with the hopper in the raised position except the few feet necessary to position the hopper over the dumpster or receptacle. Driving with the hopper raised reduces visibility and creates conditions for striking overhead objects, throwing the machine off-balance and other hazards.*

## **BASIC PowerBoss<sup>®</sup> SAFETY (Continued)**

2. *Travel slowly on grades.*
3. *Place a block or chock behind the wheels when parking on inclines.*
4. *Use special care when traveling on wet surfaces.*
5. *Observe all proper procedures for operation and maintenance of the sweeper, as outlined in this manual.*
6. *Remain alert at all times to people and equipment in and around your area of operation.*

### **ATTENTION!**

1. *Do not operate the #2 RTR lever before the #1 light illuminates.*
2. *Never push or tow a machine faster than 6 mph.*



## BASIC OPERATING CONTROLS

**IGNITION SWITCH** The machine has a four position key switch used to turn the machine's electric power on and off.

**STARTER** To start gasoline powered machines, turn the key clockwise to the **Start** position. When the engine starts, release the key. To stop the engine, turn the key to **OFF**.  
To start diesel engines, turn the ignition key counterclockwise to the **Glow Plug warming position** for **20 seconds**. After 20 seconds turn ignition key clockwise to the **Start** position. When engine starts release key.

**NOTE**

**If the engine does not start after 10 seconds, release the key, wait 1 minute and repeat the procedure.**

**HORN** The horn is activated by pressing the horn button located on the right side of the operator.

**FUEL LEVEL GAUGE** The fuel gauge indicates the amount of fuel remaining in the tank.

**VOLTMETER AMP GAUGE** The **Voltmeter** used on gas & LP units or **Amp Gauge** used on diesel units indicates the charging current which is being sent to the battery by the alternator. It also indicates a drop in voltage when the alternator is not charging.

**HOUR METER** The hour meter records the number of hours the machine has been operated, providing a helpful guide for performing routine maintenance tasks.

**ENGINE OIL PRESSURE** The engine oil pressure gauge ranges from 0 psi to 60 psi. A reading below 7 psi indicates problems which may result in damage to the engine.

**ENGINE COOLANT TEMPERATURE GAUGE** The engine coolant temperature gauge registers the temperature of the engine coolant. Temperatures above 220°F indicate an overheating engine.

## BASIC OPERATING CONTROLS (Continued)

### THROTTLE

The throttle adjusts the engine speed from idle to the operating speed.

- The throttle should be in the IDLE position when starting the engine and immediately before shutdown.
- Full throttle position should be used during operation to ensure proper broom speed and dust control.

### DIRECTIONAL CONTROL PEDAL

The directional control pedal controls the speed and direction of the machine. It is also used for slowing the machine or stopping.

- To propel the machine forward, apply pressure to the front of the pedal, increasing pressure to increase speed.
- To propel the machine backward, apply pressure to the rear of the pedal.
- To slow or stop the machine, move the foot pedal into neutral.
- For emergency stops, move the foot pedal past neutral and into the opposite position.



**Use for emergency stops only! Constant use of this braking method may result in damage to the drive components.**

The sweeper is equipped with a speed limiter. A stop is mounted under the directional control pedal and can be raised to reduce the maximum speed.

### PARKING BRAKE

The hydraulic drum brakes on the two front wheels are operated by pressing on the brake pedal. The parking brake is cable activated. To engage the parking brake pull upward on the hand brake lever located on the left side of the front wall of the operator's compartment.

## SWEEPING CONTROLS

### **BROOM CONTROL LEVER**

The broom control lever activates the brooms. (“Side Broom OFF” position activates the main broom only.)

**NOTE**

**The main broom and side broom may be lowered independently.**

**NOTE**

**The “OFF” position is achieved by placing the broom control lever in the center of the slot. Both broom motors (main & side) are de-activated by taking this action.**

### **MAIN BROOM HANDLE**

The main broom handle to the immediate left of the driver raises and lowers the main broom. For normal sweeping, position the handle at the **LOWER** position on the handle slot.

- For extremely uneven floor, position the handle at the **FLOAT** position on the handle slot.

**NOTE**

**Extensive use of the FLOAT position reduces broom life.**

- When not sweeping, position and lock the handle to the **RAISE** position on the handle slot.

### **SIDE BROOM HANDLE**

The side broom handle to the immediate left of the driver raises and lowers the side broom.

- When not sweeping, the side broom should remain in the **RAISE** position.
- To lower the side broom, position the handle to the **LOWER** position in the handle slot.

## DEBRIS HOPPER DUMP CONTROLS

### HOPPER FILTER SHAKER BUTTON

This button is used to activate the filter shakers prior to dumping or as needed during sweeping operation. It is located to the left hand side of the instrument panel.

To shake the filter:

1. Bring the machine to a complete stop.
2. Place the broom control lever in the **OFF** position.
3. Press and hold the filter shaker button for 20 to 30 seconds.
4. Place the broom control lever in the **ON** position and resume sweeping.



*Do not leave the hopper in the RAISE position for an extended period of time.*

### HIGH DUMP MODELS

The two far left levers on the front of the control panel are used to raise the hopper to any height up to 60" (1.52 m) and dump it.

- To raise the hopper, pull back Lever 1 to the **RAISE** position and hold until the hopper raises to the proper height for the dumpster or container.
- To empty debris, pull back Lever 2 to the **DUMP** position to rotate the hopper forward and empty the debris.
- To rotate the hopper back, push Lever 2 forward to the **RETURN** position until the hopper rotates and stops.
- To lower the hopper, push Lever 1 forward to the **LOWER** position until the hopper stops.

### ROTARY TRASH RELOCATOR (RTR™)

Rotary Trash Relocator (RTR™) is a standard feature on high-dump models. Its purpose is to increase the holding capacity of the debris hopper to make dumping the hopper necessary less frequently.

## OPERATING PROCEDURES

### PRE-OPERATION CHECKS

Prior to starting the engine, check the following:

1. Engine oil level
2. Engine coolant level
3. Fuel level
4. Hydraulic fluid level
5. Brakes, steering and directional controls
6. The floor beneath the machine for signs of fluid leaks

Fluid levels should be correct. Brakes, steering and directional controls should be functioning properly. Hoses, lines and tanks should be free of damage and leaks.

### STARTING



**WARNING**

*Before starting the engine, sit in the operator's seat and make sure the parking brake is locked.*

1. Make sure the directional control pedal is in the neutral position.
2. Make sure the throttle is in the idle position.
3. Gasoline-powered: Turn the ignition key to the **ON** position, push the button located just below the key. When the engine starts, release the button. If the engine is cold, pull out the choke knob and repeat the above procedure. When the engine is running smoothly, push the choke knob in.



**CAUTION**

*If the engine fails to start, do not continue cranking for more than ten seconds. Allow the starter motor to cool between attempts.*

4. Move the machine forward or backward as follows:
  - **Forward:** Apply pressure to the front of the directional control pedal, increasing pressure to increase speed.
  - **Reverse:** Apply pressure to the rear of the pedal, increasing pressure to increase speed.

**SLOWING AND STOPPING**

1. Allow the directional control pedal to move into neutral. The machine will slow and coast to a stop.

**OPERATING ON GRADES**

1. Always travel slowly.
2. Exercise extreme caution when traveling across or turning on grades.

**SWEEPING**

1. Lower the Brooms
  - \* When sweeping extremely uneven floors, position the main broom handle at **FLOAT** on the handle slot.
  - \* Lower the side broom by positioning the side broom handle at **LOWER** in the handle slot.
  - \* Lower the main broom by positioning the main broom handle to **LOWER** on the handle slot.
2. Activate the broom motors.
  - \* Activate both main and side broom motors by pushing the broom and brush control lever to the **ON** position.
  - \* Activate the main broom motor by pulling the broom and brush control lever to the **SIDE BROOM OFF** position.

**NOTE**

**Broom control lever must be in the center OFF position.**

3. Drive the machine over the area to be swept.

**EMPTYING THE HOPPER**  
**High Dump Models**

1. Drive the machine to the dumping area.
2. Use the directional control pedal to position the machine so that the space between the machine and the container or dumpster is adequate to raise the hopper.
3. Reduce the engine speed.
4. Pull back Lever 1 to the **RAISE** position and hold until the bottom of the hopper is high enough to clear the top of the container.

**⚠ WARNING**

*Never place your hands or other body parts near the lift arms when the hopper is operating.*

5. Use the directional control pedal to slowly and carefully move the machine forward until the hopper is properly positioned to dump the debris into the container.

**⚠ WARNING**

*It is unsafe to travel an extended distance with the hopper raised. Travel only the distance necessary to position the hopper.*

6. Shake the filters for 20-30 seconds. Pull back Lever 2 to the **DUMP** position to rotate the hopper forward and empty the debris.
7. After the hopper empties, push Lever 2 forward to the **RETURN** position until the hopper rotates and stops.
8. Slowly back the machine away from the dumpster approximately 5 feet.
9. Push Lever 1 forward to the **LOWER** position until the hopper stops.

**USING THE  
ROTARY TRASH  
RELOCATOR  
(RTR™)**

1. Use the directional control pedal to stop the machine on a level surface.
2. Move the throttle to the **IDLE** position.

**NOTE**

**As you complete Steps three and four, observe the two red lights labeled 1 and 2 in the upper left corner of the control pane.**

- Light 1 illuminates when the hopper reaches the minimum height required to use the RTR™ feature.
  - Light 2 illuminates when the hopper reaches the rotation stop point.
3. Pull back Lever 1 to the **RAISE** position and hold until Light 1 illuminates, then release.

**⚠ WARNING**

*Make sure no one is in the area under or around the hopper.*

**NOTE**

4. Pull back Lever 2 to the DUMP position and hold until Light 2 illuminates, then release.

**This rotates the hopper, causing the debris to move from the rear entrance to the front wall of the hopper. Rotating beyond this point will cause the debris to be dumped from the hopper.**

5. Push Lever 2 forward to the RETURN position until the hopper rotates back and stops.
6. Push Lever 1 forward to the LOWER position until the hopper returns to the normal operating position.
7. Move the throttle to the RUN position and resume sweeping.

**TRANSPORTING  
THE MACHINE  
Loading**

1. Position the machine on the transport vehicle or trailer and apply the parking brake.
2. Tie the machine down using the tie down holes in the frame behind both front wheels and in the rear center of the frame.

**NOTE**

**Pushing**

**Attach the tie downs to the frame only.**

1. Push the machine from the front or rear using the bumpers only.

**ATTENTION!**

***Do not tow or push the machine a distance of more than .5 miles (.80 kilometers) or faster than one mile per hour (1.61 km). Exceeding these restrictions may cause damage to the hydraulic system. If towing will exceed the above restrictions, the rear wheel must be raised or supported by a dolly.***



## PLANNED MAINTENANCE CHART INTRODUCTION

Regular maintenance on your sweeper results in better cleaning, faster cleaning and a prolonged service life for the equipment and components. This section contains the following information to help you give your sweeper the maintenance attention it requires:

- A Planned Maintenance Chart
- Service Instructions for Required Maintenance Tasks

Because it is extremely important to your safety, you will see the following WARNING repeated throughout this section:



*Never attempt to perform any service on the equipment or components until the engine is OFF, the parking brake is LOCKED, and the wheels are CHOCKED.*

**PLANNED MAINTENANCE CHART**

FREQUENCY (IN HOURS)					SERVICE (BY MAINTENANCE AREA)
DAILY	50	100	200	500	
		X			<p><b>ENGINE</b></p> <p>Pressure wash engine</p> <p><i>For additional maintenance requirements, refer to the engine manual.</i></p>
X					<p><b>AIR INTAKE SYSTEM</b></p> <p>Empty rubber dust cup of air filter element.</p> <p>Clean air filter. <i>NOTE: Clean more often in dusty conditions.</i></p>
	X		X		<p>Replace air filter.</p>
		X			<p><b>ELECTRICAL SYSTEM</b></p> <p>Check electrolyte level in battery cells and fill as needed.</p>
			X		<p>Clean battery top.</p>
X					<p><b>COOLANT SYSTEM</b></p> <p>Check coolant level and fill as needed.</p>
	X				<p>Inspect radiator fins and clean as needed.</p>
		X			<p>Blow out radiator fins.</p>

**PLANNED MAINTENANCE CHART (Continued)**

FREQUENCY (IN HOURS)					SERVICE (BY MAINTENANCE AREA)
DAILY	50	100	200	500	
					<b>HYDRAULIC SYSTEM</b>
X					Check hydraulic reservoir gauge and fill as needed.
				X	Replace breather cap filter element.
				X	Replace hydraulic fluid and filter
X					Check functioning of directional control pedal and adjust as needed.
				X	Clean hydraulic fluid strainer in reservoir.
	X				Inspect hydraulic oil cooler fins and clean as needed .
		X			Blow out hydraulic oil cooler fins with compressed air .
					<b>SWEEPING COMPONENTS</b>
X					Inspect brooms for wear and remove strings and debris from bristles and drive assembly.
	X				Inspect broom skirts for wear and adjust or replace as needed.
	X				Rotate main broom end-to-end.
	X				Perform main broom adjustment test and adjust as needed.
X					Inspect the side broom for wear and adjust as needed.
					<i>Replace main and side brooms as needed. Main Broom—Bristles are 1" in length. Side Broom—Bristles are 3" in length.</i>

**PLANNED MAINTENANCE CHART (Continued)**

FREQUENCY (IN HOURS)					SERVICE (BY MAINTENANCE AREA)
DAILY	50	100	200	500	
					<b>HOPPER</b>
X					Check hopper filters and clean or replace as needed.
	X				Check hopper clearance from floor and adjust as needed.
X					Inspect the hopper flaps for wear or damage and replace as needed.
		X			Inspect hopper side and frame seals for wear or damage. Adjust or replace as needed.
				X	Lubricate the pillow blocks supporting the dump mechanism.
					<b>STEERING</b>
				X	Lubricate steering cylinder rod ends.
				X	Lubricate steering fork assembly.
	X				Check for leaks.
					<b>PARKING BRAKE</b>
			X		Check for proper functioning and adjust as needed.

**PLANNED MAINTENANCE CHART (Continued)**

FREQUENCY (IN HOURS)					SERVICE (BY MAINTENANCE AREA)
DAILY	50	100	200	500	
X			X		<p><b>TIRES</b></p> <p>Visually inspect for wear and damage. Repair or replace as needed.</p> <p>Check pneumatic tires for proper air pressure (110 psi).</p>
				X	<p><b>MISCELLANEOUS</b></p> <p>Inspect latches and hinges. Tighten and lubricate as needed.</p>
			X		<p>Check anti-static drag chain on rear wall of broom chamber for damage or excessive wear. Replace as needed.</p>
				X	<p>Check side broom lift cable and lift cable for wear.</p>
X					<p><b>IMPELLER</b></p> <p>Check for hydraulic fluid leaks.</p>

## SERVICE INSTRUCTIONS ENGINE

---

Maintenance requirements and service instructions for your sweeper engine are outlined in the following parts of this Maintenance Section:

- \* Air Intake System
- \* Electrical System
- \* Fuel System
- \* Coolant System
- \* Lubrication System

All basic maintenance tasks are listed with their recommended frequencies on the Planned Maintenance Chart in this manual. Important additional maintenance requirements and instructions are explained in the engine manual which comes with your machine.

---



**WARNING**

*Never attempt to perform any service on the equipment or components until the engine is OFF, the parking brake is LOCKED, and the wheels are CHOCKED.*

## **SERVICE INSTRUCTIONS (CONTINUED)**

### **AIR INTAKE SYSTEM**

#### **AIR FILTER REMOVAL**

1. Turn off the engine and set the parking brake.
2. Lift the engine cover.
3. Locate the air filter and unclamp the retaining clamp.
4. Remove the dust cup.
5. Pull the rubber plug out of the dust cup and empty the contents.
6. Pull the air filter out of its housing.

#### **AIR FILTER CLEANING**

1. Once you have removed the air filter, empty the dust cup and clean the interior of the air filter housing.
2. Use an air hose to blow out the air filter. Air pressure should be 100 psi or less.

#### **AIR FILTER INSPECTION**

1. After you clean the air filter, check it for holes by passing a light bulb inside it.

#### **AIR FILTER INSTALLATION**

1. Wipe out the air cleaner housing with a damp cloth. Be sure all dirt is removed.
2. Install the cleaned replacement filter so that the fins are at the far end of the housing. Be careful not to damage the fins.
3. Replace the wing nut and tighten it.
4. Replace the rubber plug in the dust cup.
5. Replace dust cup, being sure embossed word “top” on cup is positioned correctly (up).
6. Tighten the ring clamp.
7. Check the condition of intake hoses and clamps. Close engine cover.

## SERVICE INSTRUCTIONS (CONTINUED) ELECTRICAL SYSTEM

### BATTERY CLEANING

1. Combine baking soda and water in a strong solution.
2. Brush the solution over the battery top, including terminals and cable clamps. Make sure the solution does not enter the battery.
3. Using a wire brush, clean the terminal posts and cable clamps.
4. Apply a thin coating of petroleum jelly to the terminals and cable clamps.

### BATTERY REPLACEMENT



*Remove the negative battery cable before you remove the positive battery cable. This is done to prevent accidental electrical shorting which can result in personal injury.*

1. Disconnect the negative (-) cable and then the positive (+) cable.
2. Remove the battery.
3. Install the new battery.
4. Connect the positive (+) battery cable first, then the negative (-) cable.

### CIRCUIT BREAKERS

If a circuit breaker trips, it can be reset by pressing the reset button in the center of the breaker. (The circuit breakers are located on the instrument panel below the steering wheel.)

### FUSES

Fuses are located in the fuse panel behind the hopper on the firewall upper right corner when facing the unit



*Safety Arm Must Be Engaged When Checking These Fuses*



## SERVICE INSTRUCTIONS (CONTINUED) FUEL SYSTEM

**⚠ WARNING**

1. *Never attempt to perform any service on the equipment or components until the engine is OFF, the parking brake is LOCKED, and the wheels are CHOCKED.*
2. *Never operate an LPG powered sweeper when any component in the fuel system is malfunctioning or leaking.*
3. *Never bypass safety components unless you are testing them.*
4. *Replace any defective safety components before operation the sweeper.*
5. *During repair or servicing of the fuel system, work in a properly ventilated area and do not smoke or allow an open flame near the fuel system.*
6. *When disconnecting the tank coupling, always wear gloves. LPG fuel can freeze bare hands.*
7. *Under no circumstances should the fuel filter lock be bypassed, except when testing. After testing, always reconnect lock. Bypassing the fuel filter lock after testing creates a potential fire hazard.*

Tier II compliant fuel system  
Refer to P.S.I Service Manual

## SERVICE INSTRUCTIONS (CONTINUED) COOLANT SYSTEM

### BLOWING OUT RADIATOR FINS

**NOTE**

Make sure radiator is cool before blowing out the radiator fins with compressed air.

### REVERSE FLOW FLUSHING

1. At the engine, disconnect the hoses.
2. Make sure the radiator cap is on tight.
3. Using a hose clamp, clamp a flushing gun onto the lower hose.
4. Turn on the water and fill the radiator.
5. To keep from damaging the radiator, apply air pressure slowly and carefully.
6. Shut off the air pressure, refill the radiator with water, and reapply the air pressure. You will need to repeat these steps until water flushed from the radiator runs out clear.
7. Inspect and clean the radiator cap.
8. Inspect and reconnect the hoses.
9. Refill the radiator with coolant.

**NOTE**

Use a 50/50 mixture of water and an anti-freeze with an ethylene glycol base.

## **SERVICE INSTRUCTIONS (CONTINUED) LUBRICATION**

Gasoline and LPG Engines: Use any SF or SG rated oil meeting API specifications and suited to seasonal temperatures.

Refer to the Engine Manufacturer's Operator Manual for these specifications.

### **CHANGING ENGINE OIL**

1. Place a drain pan under the lowest end of the engine.
2. Remove the drain plug and allow the oil to drain into the pan.
3. Remove the used oil filter and replace with a new one.
4. Dispose of the oil and oil filter in an approved manner.
5. Remove the engine oil cap, add oil in the amounts listed in the engine manual, then secure the cap.

**SERVICE INSTRUCTIONS (CONTINUED)  
LUBRICATION POINTS**

<b>Lubrication</b>	<b>Type of Lubrication</b>	<b>Frequency (In Hours)</b>
Steering Cylinder (2 fittings)	Grease	500
Steering Fork Assembly	Grease	500
Pillow Block Supporting Dump Mechanism (2 fittings)	Lithium Grease	500
Hood Latches & Hinges	Oil	500

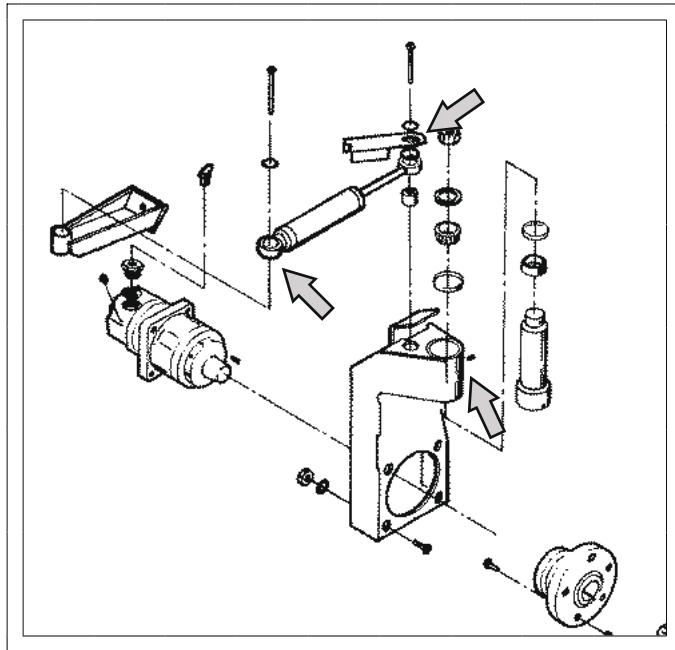

**Powerflex Steering Lubrication Points**

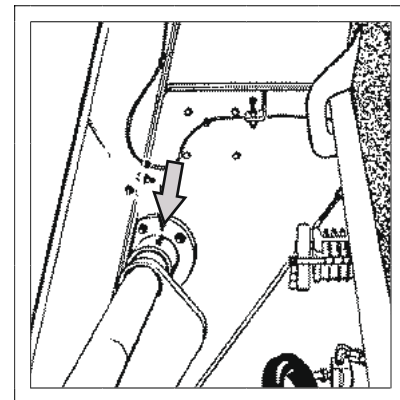

**Dump Arm Pillow Block  
Lubrication Points**

↑ Indicates location  
of grease fittings

## SERVICE INSTRUCTIONS (CONTINUED) HYDRAULICS SYSTEM

### FILLING THE FLUID RESERVOIR

**NOTE**

The reservoir is located inside the machine and is accessible by tilting the operator's seat forward.

1. When the machine is cool and the hopper is in the lowered position, remove the dipstick. Fluid level should be between the high and low marks on the dipstick.

**CAUTION**

**DO NOT OVERFILL! DO NOT USE TRANSMISSION FLUID**

PowerBoss, Inc. recommends 15w-40w motor oil We  
Currently use EXXON XD-3

2. If the fluid level is not acceptable, add hydraulic fluid.

### HYDRAULIC FLUID VISCOSITY SPECIFICATIONS

---

SUS @ 100° F 510-560  
SUS @ 210° F 78-84

### MAINTAINING HYDRAULIC OIL COOLER EFFICIENCY

Your machine is equipped with a hydraulic oil cooler, it is integrated with the radiator and utilizes exhausted radiator air from the engine fan to cool the hydraulic fluid. To maintain its efficiency, periodically blow out the radiator & oil cooler fins with compressed air. 100 p.s.i. is maximum

### CHANGING THE HYDRAULIC FLUID

1. Turn off the engine and engage the parking brake.
2. Place a drain pan on the floor below the reservoir.
3. Remove the drain plug located on the bottom rear of the reservoir and allow the fluid to drain.
4. Discard the fluid in an approved manner, then replace and retighten the drain plug.
5. Remove the filler / breather cap located on top of the reservoir and fill the reservoir with approved hydraulic fluid.

## SERVICE INSTRUCTIONS (CONTINUED) HYDRAULICS SYSTEM (CONTINUED)

**NOTE** Ten (10) gallons (US) of fluid are required.

6. Install the filler cap assembly.
7. Check the drain plug for leakage.

### CHANGING THE HYDRAULIC FLUID FILTER

1. Turn off the engine and engage the parking brake.
2. Unscrew the oil filter cartridge from the mount and discard in an approved manner.
3. Apply a thin coating of fluid to the seal of a new filter element.
4. Thread onto the mount and hand tighten.
5. Tighten an additional one-half turn beyond hand tight.

**NOTE** Do not over tighten.

5. Start the machine, shut it off, then check for leakage.

### ADJUSTING THE DIRECTIONAL CONTROL RETURN SPRING

You may encounter “creeping” problems from time to time. Creeping means the machine moves backward or forward when the forward/reverse pedal is in neutral. A grinding noise when the engine is shut down is a so an indicator that the directional control return spring needs adjusting. If this occurs, perform the procedure which follows:

1. Turn off the engine, engage the parking brake and chock both wheels.
2. Jack the rear of the machine so that the rear tire just clears the floor. Use two jack stands to support the machine.



***DO NOT USE A JACK ALONE TO HOLD THE MACHINE!!!***

## **SERVICE INSTRUCTIONS (CONTINUED) HYDRAULICS SYSTEM (CONTINUED)**

3. Locate the forward / reverse adjustment bracket mounted beneath the pump on the pump mounting plate.
4. Slightly loosen the bolt on the center of the bracket.
5. Loosen the locking nut on each of the adjusting bolts on the side of the bracket closest to the pump mounting plate.
6. From the operator's seat, start the engine and run at half throttle.
7. Turn the adjusting bolts while watching the rear wheel. Continue to adjust until the rear wheel does not turn in either direction.
8. Fully open the throttle. Push the directional control pedal forward and backward to be sure the pump stays in neutral. Check the wheel again and adjust as needed until the wheel remains motionless.
9. Retighten all the locking nuts and bolts.
10. Turn the engine off and lower the machine to the floor.

## **SERVICE INSTRUCTIONS (CONTINUED) SWEEP COMPONENTS**

### **BROOM DOOR FLAP INSPECTION**

**NOTE**

**Perform this inspection when the machine is parked on a level surface.**

1. Turn the machine off and lock the parking brake.
2. Inspect broom door flaps for wear and damage. Flap clearance should be  $\frac{1}{8}$ " (3.18 mm) above the floor.
3. Worn and damaged flaps should be replaced immediately to maintain proper dust control.

### **BROOM DOOR FLAP REPLACEMENT AND ADJUSTMENT**

The flaps are attached to the broom doors by a retainer bar, hex bolts and nuts. To remove the flaps, remove the nuts, bolts and retainer bar. To adjust the flaps, loosen the nuts and bolts, slide the flap up or down as needed. Retighten the nuts and bolts.

### **MAIN BROOM ADJUSTMENT**

**NOTE**

**Perform this adjustment on a flat, smooth test surface.**

1. Drive the machine onto the test surface with the main broom in the **RAISE** position.
2. Set the parking brake and position the main broom to the **NORMAL** position.
3. Push the broom control switch to the **ON** position to activate the broom motor and open the throttle to full RPM.
4. Allow about 45 seconds for the broom to operate, then deactivate the broom motor and raise the broom.

**NOTE**

**Test time will vary according to the test surface used.**

5. Drive the machine clear of the test site.



## SERVICE INSTRUCTIONS (CONTINUED) SWEEP COMPONENTS (CONTINUED)

6. Examine the polished pattern made by the broom on the test area.

**NOTE**

A rectangular shape the length of the main broom, 2" (5.08 cm) wide, indicates the main broom is properly adjusted. A pattern smaller than 2" (5.08 cm) indicates need for lower adjustment. A pattern wider than 2" (5.08 cm) indicates a need for higher adjustment. If pattern is tapered from end to end instead of rectangular, see Taper Adjustment on the next page.

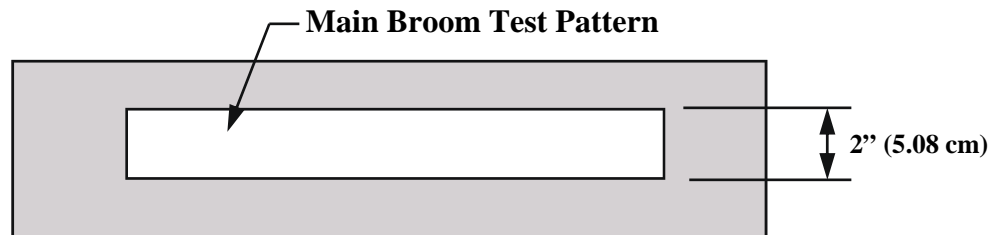

### MAIN BROOM HEIGHT ADJUSTMENT

1. Turn the machine off and lock the parking brake.
2. Position the main broom lever in the **LOWER** position.

**NOTE**

**The adjustment knob is located in the engine compartment on the broom control handle pivot.**

3. Turn the broom adjusting knob clockwise one-eighth turn to free the wingnut.
4. Turn the wingnut counter-clockwise to allow space for adjustment.
5. Make a lower or higher adjustment with the knob as required.
6. Retighten the wingnut.
7. Repeat the main broom adjustment test to see that the broom is properly adjusted.

## SERVICE INSTRUCTIONS (CONTINUED) SWEEP COMPONENTS (CONTINUED)

### MAIN BROOM TAPER ADJUSTMENT

**NOTE**

It is not usually necessary to perform this adjustment. However, if the main broom adjustment test shows a pattern that is tapered in length (one end is wider than the other), perform the procedures which follow.

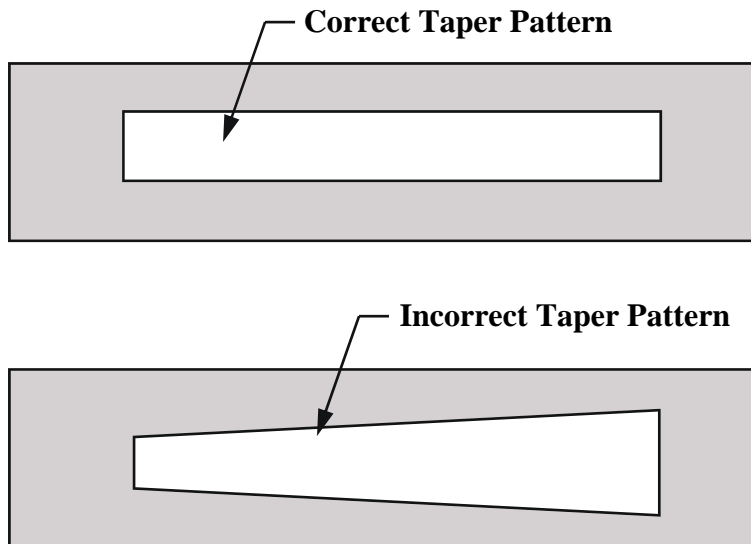

### Main Broom Taper Patterns

1. Locate the adjusting screws directly beneath the hydraulic pump.
2. Loosen the jam nuts on the adjusting screws, and loosen the retaining bolt on the inside of the mounting bracket.
3. Use the adjusting screws to raise or lower the left end of the main broom. (The right end of the broom remains fixed. All adjustments affect the left end of the broom.)
4. After adjustment, tighten the retainer bolt and adjusting screws.
5. Repeat the main broom adjustment test to see that the broom is properly adjusted.

## **SERVICE INSTRUCTIONS (CONTINUED) SWEEP COMPONENTS (CONTINUED)**

### **MAIN BROOM REPLACEMENT** (Bristles worn to a length of 1 inch; 2.54 cm or less)

1. Turn the engine off and lock the parking brake.
2. Push the main broom control lever to the **LOWER** position
3. Open the left broom chamber door (the door opposite the driver's seat).
4. Using a ¾" wrench, remove the hex bolt on the main broom idler mount.
5. Pull the main broom idler mount straight out to remove.
6. Grasp the main broom by the plastic drive hub, pull the main broom straight out and clear of the broom chamber.
7. Depending on broom condition, you can either rotate the old broom end-to-end and re-install it or you can install a new broom. Slide the main broom into the broom chamber and align the broom with the metal drive hub located at the far side of the broom chamber.

If a worn broom is being replaced, install the new broom by first adjusting the broom arms up, to better match the position of the drive hub with the hub on the new broom.

8. Once the broom is started onto the drive hubs, rotate the broom counter-clockwise while pushing lightly against the broom.
9. Once the broom is fully engaged, replace the idler hub while aligning the seats in the idler hub with the broom's drive hub ears.
10. Install the retaining bolt into position and tighten with the wrench.
11. Close and latch the left broom door.
12. Perform a main broom adjustment test and adjust as needed.

## **SERVICE INSTRUCTIONS (CONTINUED) SWEEP COMPONENTS (CONTINUED)**

### **SIDE BROOM ANGLE ADJUSTMENT**

The angle adjustment is controlled with a stop bolt. This stop bolt is located at the top front of the side broom arm (under the spring). To increase the angle of the side broom, loosen the jam nut and turn the stop bolt counter-clockwise. Be sure to retighten the jam nut back down once the adjustment is made.

### **SIDE BROOM HEIGHT (WEAR) ADJUSTMENT**

The height of the side broom is adjusted with the use of a stop bolt located at the lower rear of the curb broom arm. As the side broom wears, it will be necessary to lower the arm. To lower the side broom, loosen the jam nut on the stop bolt. Turn the stop bolt in a counter-clockwise direction, check the side broom for proper contact and re-tighten the jam nut.

### **SIDE BROOM LIFT CABLE ADJUSTMENT**

This adjustment is made at the cable clevis attached to the side broom assembly. It controls the height of the side broom in the **RAISED** position. This adjustment must be made with the hopper fully lowered.

1. Pull the side broom lever into the **RAISED** position.
2. Loosen the locknut on the threaded rod at the clevis.
3. Turn the threaded rod in or out to set the side broom in the maximum raised position.
4. Secure the cable adjustment by tightening the locknut.

## SERVICE INSTRUCTIONS (CONTINUED) SWEEP COMPONENTS (CONTINUED)

### SIDE BROOM REPLACEMENT (Bristles worn to a length of 3 inches; 7.62 cm or less)

**NOTE**

**The side broom features a quick release mechanism which enables the operator to remove the brush in seconds.**

1. Raise the side broom and lock in the RAISE position.
2. Turn the side broom by hand until the brush retainer bar is accessible.
3. Lift the bar and turn the broom clockwise (about one eighth of a turn) until the lock pins in the broom disengage from the drive plate.
4. Install the new broom by positioning the three drive pins into the pilot holes of the drive plate.
5. Lift and rotate the broom until the broom retainer bar springs into the locked position.
6. Check to make sure all the drive pins are properly engaged.

## SERVICE INSTRUCTIONS (CONTINUED) HOPPER

**NOTE**

It is not usually necessary to remove the hopper on high dump models. However, if it becomes necessary for maintenance or to install an option, use the following procedure to remove:

### HIGH DUMP HOPPER REMOVAL

1. Park the machine on a level surface and engage the parking brake.
2. Raise the hopper and position the high dump hopper dolly, a platform truck or similar four wheeled cart under the hopper.
3. Set the hopper down on the truck and turn the engine off.
4. Cycle the rotation control handle (#2) in both positions to relieve any residual hydraulic pressure.
5. Remove three bolts, washers, nuts and backing plate.
6. Disconnect the wire connections at the right side of the hopper.
7. While spreading the dump arms slightly, roll the hopper away from the machine.

### HIGH DUMP HOPPER REPLACEMENT

1. Position the hopper on the dolly so as to align the mounting holes in the sides of the hopper with the rotation mounts on the arms. Lift arms should be positioned about  $\frac{1}{3}$  of the way up.
2. Engage the lift arm rotation plates with the mounting bolts on each side of the hopper.
3. Start the machine and lift the hopper.
4. Drive away from the hopper dolly or cart.
5. Lower the hopper.
6. Engage the wire connections at the right side of the hopper.

## **SERVICE INSTRUCTIONS (CONTINUED) HOPPER (CONTINUED)**

### **FILTER REMOVAL**

1. Release the latch on the hopper cover and raise the cover.
2. Disconnect the wire harness leading to the filter shaker motor.
3. Unscrew the two screws (each attached using one conical washer and an isolator) securing the filter retainer bars to the hopper.
4. Remove the shaker motor assembly and filter retainer bars.
5. Lift out the panel filter.

### **FILTER CLEANING**

The dust control filter is a polyester type element filter. It may be vacuumed, blown out with compressed air, tapped against the floor or washed with soap and water.

1. If blown out with compressed air, use 100 psi or less.
2. If washed with soap and water, use 40 psi water pressure or less.

**NOTE**

**Make sure the filters are thoroughly dried while standing on their side before installing in the hopper. Do not install or use a wet filter.**

### **FILTER REPLACEMENT**

1. Insert the panel filter.
2. Install the shaker motor assembly.
3. Install and tighten the four filter retaining screws and isolators.
4. Hook the wire harness to the filter shaker motors.
5. Close the hopper cover and secure the latch.

## SERVICE INSTRUCTIONS (CONTINUED) HOPPER (CONTINUED)

### FLOOR CLEARANCE AND DUMP ADJUSTMENTS

In order to perform properly, the hopper must maintain a distance of 3½” (8.89 cm) from the floor to the rear hopper entrance lip. The front of the hopper should be adjusted so that the front bumper aligns with the hopper frame where the two meet. When properly adjusted, the front edge of the hopper will be 5” (12.7 cm) to 6” (15.24 cm) from the floor.

### ADJUSTING MAXIMUM HOPPER DUMP ANGLE

1. Park the machine on a level surface, shut off the engine and engage the parking brake.



*Do not rely upon the hydraulic cylinders to keep the hopper raised for maintenance. Always engage the safety arm before servicing the hopper.*

**SAFETY ARM  
ENGAGED**

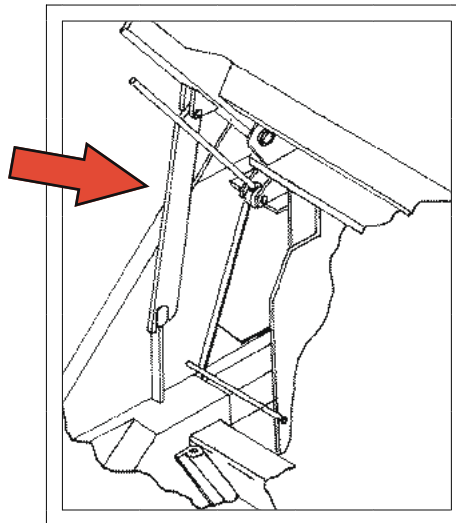

2. Adjust the lift arm stop bolts located on top of the wheel wells as low as possible while still allowing the side broom assembly to clear the lift arms when the hopper is in the **NORMAL** position. Be sure that both lift arms contact the stop bolts at the same time.

**NOTE**

**This may involve raising and lowering the hopper several times.**

3. After adjustment, with the hopper down, use the two adjustable stops located on the rotation plates on both sides of the hopper to establish 3½” (8.89 cm) clearance between the rear hopper entrance lip and the floor.



## SERVICE INSTRUCTIONS (CONTINUED) HOPPER (CONTINUED)

**NOTE**

The stop on the driver's side is located immediately below the cylinder rod end and is threaded into the cylinder mount arm. The stop on the left side is located directly above the arm rotation plate.

4. After the 3½" (8.89 cm) clearance is established, make sure both stops make contact simultaneously. The lower front edge of the hopper should be 5" (12.7 cm) to 6" (15.24 cm) from the floor. A balanced adjustment of both sets of adjustment bolts is required to correctly adjust the hopper in the lower position. If the bumper is lower than the frame, after the hopper is correctly adjusted, loosen the bumper attachment bolts and reposition the front bumper.
5. Raise the hopper and rotate fully.
6. Turn the engine off.

**⚠ WARNING**

*Do not rely upon the hydraulic cylinders to keep the hopper raised for maintenance. Always engage the safety arm before servicing the hopper.*

7. Adjust the stops on the hopper mounts on each side of the hopper so that clearance between the lift arms and the cut-outs in the bumper is ¼" (6.35 mm) maximum.
8. Loosen the locking set screw in the bottom side of the rotation cylinder rod end.
9. Using the hole in the cylinder rod, turn the rod to adjust the cylinder extended length to match the hopper rotation stops.
10. Tighten the set screw.
11. Rotate the hopper back, remove the safety arm and lower the hopper.

### VACUUM GASKET MOUNT ADJUSTMENT

1. With the hopper in the normal position, observe contact between the back of the hopper and gasket. If complete seal is not maintained, raise the high dump hopper.

**⚠ WARNING**

*Do not rely upon the hydraulic cylinders to keep the hopper raised for maintenance. Always engage the safety arm before servicing the hopper.*

## **SERVICE INSTRUCTIONS (CONTINUED) HOPPER (CONTINUED)**

2. Loosen the mounting bolts in the gasket mount. Move the assembly toward the hopper. Tighten the bolts. Test and repeat if necessary.

### **FLAP REPLACEMENT**

Flaps located at the entrance lip and on the sides of the hopper must be replaced when worn or damaged. The flap panels may be replaced separately.

1. Park the machine on a level surface and engage the parking brake.
2. Raise the hopper.



*Do not rely upon the hydraulic cylinder to keep the hopper raised for maintenance. Always engage the safety arm before servicing the hopper.*

3. Turn off the engine
4. Remove the flap retaining angle and worn or damaged flaps.
5. Install the new flaps.
6. Replace the retaining angle.

### **FRAME SEAL REPLACEMENT**

#### **FRONT FRAME SEAL**

The hopper frame seal bolts to the front edge of the engine pan. Install a new seal by folding it in half to align the holes. Doubled edge with holes goes on the bottom. Support the seal straight up while bolting the retainer bar in place. The seal should fall over the retainer bar after installation. Be certain that the seal edges are aligned to prevent twisting of the seal.

#### **SIDE FRAME SEAL**

The side frame seals should clear the floor by at least  $\frac{1}{8}$ " (3.18 cm). If the bottom of a side seal measures  $\frac{1}{2}$ " (1.27 cm) or more above the floor, readjust it or replace it by removing the bolts on the inside of the wheel wells, installing a new seal, and securing it with the bolts. The double edge with the holes goes toward the front.

## SERVICE INSTRUCTIONS (CONTINUED) PARKING BRAKE

Normal adjustment of the parking brake can be accomplished from the operator compartment. Locate the knurled handle on the parking brake lever. Turn the handle clockwise to increase brake tension.

**NOTE**

Two or three turns is usually adequate. *DO NOT OVERTIGHTEN.*

If this adjustment becomes ineffective, it will be necessary to adjust the cable length.

**⚠ WARNING**

*Do not rely upon the hydraulic cylinders to keep the hopper raised for maintenance. Always engage the safety arm before servicing in the area of the hopper.*

### ADJUSTING THE PARKING BRAKE CABLE LENGTH

1. Park the machine on a level surface and chock the wheels.
2. Place the parking brake lever in the “OFF” position.
3. Turn the knurled handle counter-clockwise as far as possible.
4. Raise the hopper and engage the safety arm.
5. Locate the cable clevis ends for the parking brake cables.
6. Disconnect the clevis ends from the bar.
7. Loosen the jam nuts at the base of the clevis.
8. Turn the clevis clockwise three or four complete turns.
9. Tighten the jam nuts and re-install the clevis ends onto the bar.
10. Adjust the knurled handle on the parking brake lever.

## SERVICE INSTRUCTIONS (CONTINUED) TIRES

### CHANGING SOLID TIRES

**NOTE**

The procedures which follow apply to **SOLID TIRES ONLY**.

1. Remove the tire from the vehicle by removing the five inner lug nuts.
2. Remove the ten hex head bolts and nuts.
3. Press the tire from the rim.
4. Press the large rim half into the new tire.
5. Mount the small rim half and secure with hex head bolts.
6. Reinstall the tire on the machine

### CHANGING PNEUMATIC TIRES

**CAUTION**

*Changing pneumatic tires must be performed in a safety cage and require special tools, PowerBoss, Inc. recommends that you have these tires changed by a professional tire dealer. (They are to be inflated to 110 psi.)*

## **SERVICE INSTRUCTIONS (CONTINUED) MISCELLANEOUS**

### **MISCELLANEOUS ADJUSTMENTS**

#### **ANTI-STATIC CHAIN ADJUSTMENT**

Each machine is equipped with an anti-static chain bolted to the back wall of the broom chamber. This should remain in contact with the floor at all times. Inspect the chain every 200 operating hours. Replace if at least one link does not drag the surface of the floor.

#### **LATCHED AND HINGE MAINTENANCE**

Latches and hinges should be inspected after every 500 hours of use. Retighten and oil if necessary.

#### **CABLES**

Inspect all cables for wear every 500 hours.

## TROUBLESHOOTING

PROBLEM	CAUSE	SOLUTION
<p>Engine will not start or runs roughly after start.</p> <p><i>NOTE: On machines with LPG fuel, also check the following:</i></p>	Battery dead.	Recharge or replace battery.
	Machine out of fuel.	Refuel
	Fuel filter plugged.	Clean or replace filter.
	Fuel line broken or obstructed.	Blow fuel line out with compressed air.
	Dirty air filter.	Clean or replace air filter.
	Problems with spark plugs, ignition points, ignition coil ignition switch, carburetor, regulator, wiring harness.	Review engine manual at back of this manual for maintenance and troubleshooting procedures.
	Tank valve not fully opened.	Open the valve slowly.
	Fuel tank type does not match fuel supply.	Use the correct tank type for the fuel supply.
	Fuel tank and lines are covered with frost.	Open shut-off valve slowly to ¼ open, start.
Defective vacuum lock-off.	Replace or repair.	

**TROUBLESHOOTING (CONTINUED)**

PROBLEM	CAUSE	SOLUTION
Engine overheats.	Low coolant level.	Supply coolant.
	Clogged radiator.	Flush radiator.
	Loose fan belt.	Tighten belt.
	Defective thermostat.	Replace thermostat.
<p>NOTE: If coolant loss has not occurred, check for malfunction of the temperature sending unit.</p>		
PowerBoss® moves slowly or does not move.	Parking brake is on.	Release brake.
	Directional control pedal jammed, damaged, or not adjusted properly.	Clear jam or adjust linkage.
	Tires skidding from contact with oil or grease.	Clean tires or drive through a solvent absorbing substance.
	Wheels jammed.	Clear jam.
Low hydraulic fluid level.	Add hydraulic fluid.	

**TROUBLESHOOTING (CONTINUED)**

PROBLEM	CAUSE	SOLUTION
PowerBoss® moves slowly or does not move (continued).	<p>Hydraulic fluid temperature too high and too thin caused by excessive load, climbing, high environment temperatures, worn pump, or improper fluid.</p> <p>Damaged or worn pump drive coupling.</p> <p>Other problems with the hydraulics system: pump failure, motor failure, relief valve leaking or stuck open.</p>	<p>Use the proper weight oil for the operation conditions; check pump.</p> <p>Replace damaged item.</p> <p>See Hydraulics System Problems in this section.</p>
PowerBoss® creeps in neutral.	Directional control pedal return spring is out of adjustment.	Perform the adjustment procedures.
Brushes do not turn or turn very slowly.	<p>Hydraulic system problem:</p> <ul style="list-style-type: none"> <li>⇒ motor</li> <li>⇒ control valve</li> <li>⇒ gear pump</li> <li>⇒ relief valve</li> </ul>	See Hydraulics System Problems in this section.



**TROUBLESHOOTING (CONTINUED)**

<b>PROBLEM</b>	<b>CAUSE</b>	<b>SOLUTION</b>
Little or no vacuum in brush compartment.	Filters clogged.	Clean filters.
	Leak or clog in hose from impeller.	Repair leaks; clear obstructions or replace hose.
	Impeller failure.	Check and repair.
Loss of dust control.	Debris in hose or impeller inlet.	Clean.
	Broom skirts or seal worn.	Replace.
	Skirt clearance from floor exceeds 1/8".	Adjust clearance.
	Dust control filters clogged.	Clean filters.
	Filter seals worn or missing.	Replace.
	Poor seal with vacuum gasket.	Visually check and adjust, if necessary.
Sweeper unit leaving debris.	Hopper full.	Dump hopper.
	Broom(s) out of adjustment.	Adjust.

**TROUBLESHOOTING (CONTINUED)**

PROBLEM	CAUSE	SOLUTION
Sweeper unit leaving debris (continued).	<p>Broom bristles worn.</p> <p>Poor performance of broom drive mechanism.</p> <p>Broom lift arms hung up with debris.</p> <p>Hopper flaps damaged or missing.</p> <p>Hopper out of adjustment.</p> <p>Dust control filters clogged.</p>	<p>Check broom for wear and adjustment.</p> <p>Check for jam in broom chamber.</p> <p>Clear out debris.</p> <p>Replace or adjust clearance.</p> <p>Check hopper clearance.</p> <p>Clean filters.</p>
Hopper does not raise or lower.	<p>Hydraulics system problem:</p> <ul style="list-style-type: none"> <li>• control valve</li> <li>• gear pump</li> <li>• lift cylinder</li> <li>• relief valve</li> </ul> <p>Hopper arms binding.</p>	<p>See Hydraulics Systems Problems in this section.</p> <p>Lubricate or adjust arm linkage.</p>

**TROUBLESHOOTING (CONTINUED)**

<b>PROBLEM</b>	<b>CAUSE</b>	<b>SOLUTION</b>
Hopper does not rotate or rotates too slowly.	Hopper load too heavy.  Hydraulics system problem: ⇒ control valve ⇒ gear pump ⇒ lift cylinder ⇒ relief valve	Dump more frequently.  See Hydraulics System Problems in this section.
Hopper lift cylinder failure.	Line to cylinder leaking.  Piston seals leaking.  Bent piston rod.	Tighten fittings or replace hose.  Replace seals.  Replace rod.
Hydraulic control valve failure	Misaligned control linkage.  Foreign matter in spool bore.  Valve seals Leaking.  O-rings leaking.  Relief valve stuck open.	Align.  Remove spool and clean bore.  Replace seals.  Replace o-rings  Clean or replace relief valve.

**TROUBLESHOOTING (CONTINUED)**

<b>PROBLEM</b>	<b>CAUSE</b>	<b>SOLUTION</b>
Hydraulic motor failure.	Motor leaking.	Replace seals.
	Drive link malfunction.	Replace drive link.
	Output shaft malfunction.	Replace output shaft and bearings.
Hydraulic gear pump failure.	Pump leaking.	Replace seals or RR Pump
	Gears worn or scored.	Rebuild pump or RR Pump
	Relief valve stuck.	Clean or replace (at control valve).
	Oil supply low.	Check and fill.
	Oil strainer clogged.	Replace strainer (inside reservoir).
	Incorrect oil.	Use recommended viscosity oil.
	Damage due to entry of air into hydraulic system.	Maintain correct hydraulic fluid level in reservoir. Keep suction hose fittings tight..

**TROUBLESHOOTING (CONTINUED)**

PROBLEM	CAUSE	SOLUTION
Hydraulic variable displacement pump failure.	Pump leaking.	Replace seals.
	Relief valve(s) stuck.	Clean or replace relief valve(s) at the pump.
	Drive coupling malfunction.	Replace defective gears.
	Control linkage out of adjustment.	Check to see if linkage is binding unfastened.
	Charge pump gears worn or scored.	Replace defective gears.
	Damage due to entry of air into hydraulic system.	Maintain correct hydraulic fluid level in reservoir. Keep suction hose fittings tight.

**TROUBLESHOOTING (CONTINUED)**

PROBLEM	CAUSE	SOLUTION
Hydraulic system noisy.	<p>Air in system.</p> <p>Relief valve dirty or damaged.</p> <p>Loose suction line.</p> <p>Clogged section filter or pump inlet line.</p> <p>Internal pump or motor damage.</p>	<p>Check fluid level in reservoir; check for loose connections or leaks.</p> <p>Clean or replace.</p> <p>Tighten fittings.</p> <p>Replace filter, clear line; change fluid in reservoir if dirty and flush system.</p> <p>Inspect and repair.</p>

## Your Page

Thank you for your purchase of the now industry standard for sweepers. PowerBoss takes great pride in offering the most dependable, reliable and value in industrial / commercial power sweepers and sweeper / scrubbers. *We set the standard.*

Our Publishing Department would like to hear from you. If you see any errors, omissions or something that just needs clarification in this manual please let us know. We are working hard toward perfection in our corner of the process to bring you the best you can buy. Please fill out the form below and comment on how you found our manual.

Thank you.

\*Name \_\_\_\_\_

\*Title: \_\_\_\_\_

\*Company Name: \_\_\_\_\_

\*Address: \_\_\_\_\_

\*Country: \_\_\_\_\_

Type of equipment or model number: \_\_\_\_\_

Comments:

\*Information is optional.

Please return to:

Manager, Publishing Department, International  
PowerBoss, Inc.  
175 Anderson Street  
Aberdeen, North Carolina 28315 USA

Phone (800) 982-7141 Toll Free





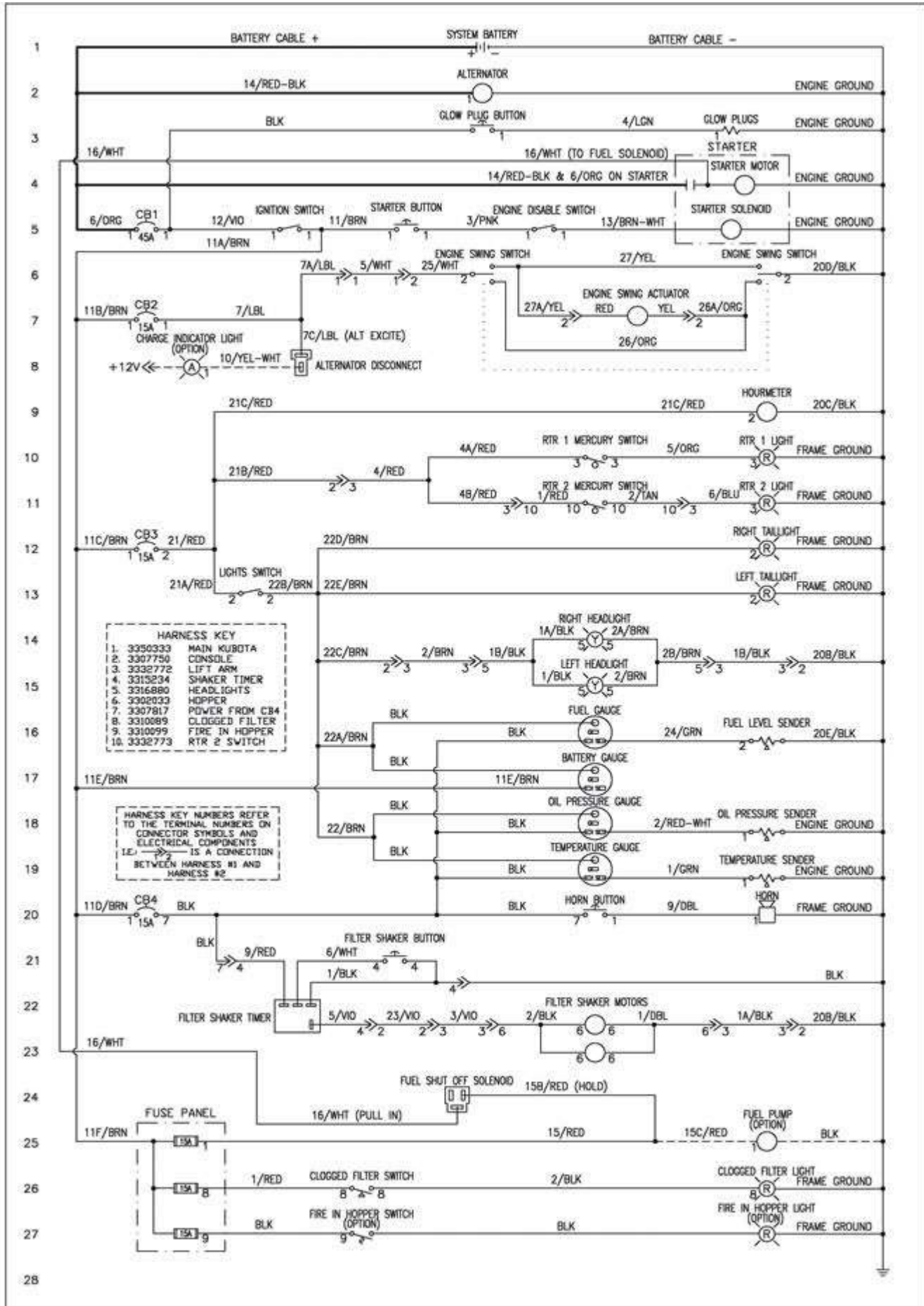

ENGINE CONNECTOR 1	
A	VSW
B	ALT EXCITE
C	FUEL PUMP -
D	FUEL PUMP +
E	AUX PWR 2
F	START COMMAND
G	REL OVALFUNCTION0
H	FUEL SELECT GAUX DISG D
J	FPPB/VVS
K	FPPB
L	SV RTN 1
N	SV EXT 1
O	CAN 3 +
P	CAN 1 -
R	SV RTN 2
S	SV EXT 2 (FPPB ONLY)

ENGINE CONNECTOR 2	
A	UNUSED
B	AUX PWR 5 RECDRC
C	AUX PWR 5
D	TACH
E	GROUND
F	AUX PWR 1
G	AUX ANA PWR
H	AUX ANA PWR
J	GOV SELECT 2
K	GOV SELECT 1
L	AUX DISG 2
M	AUX DISG 3
N	V5 +
P	V5 -
R	AUX ANA PWR
S	SEV RELAYED POWER

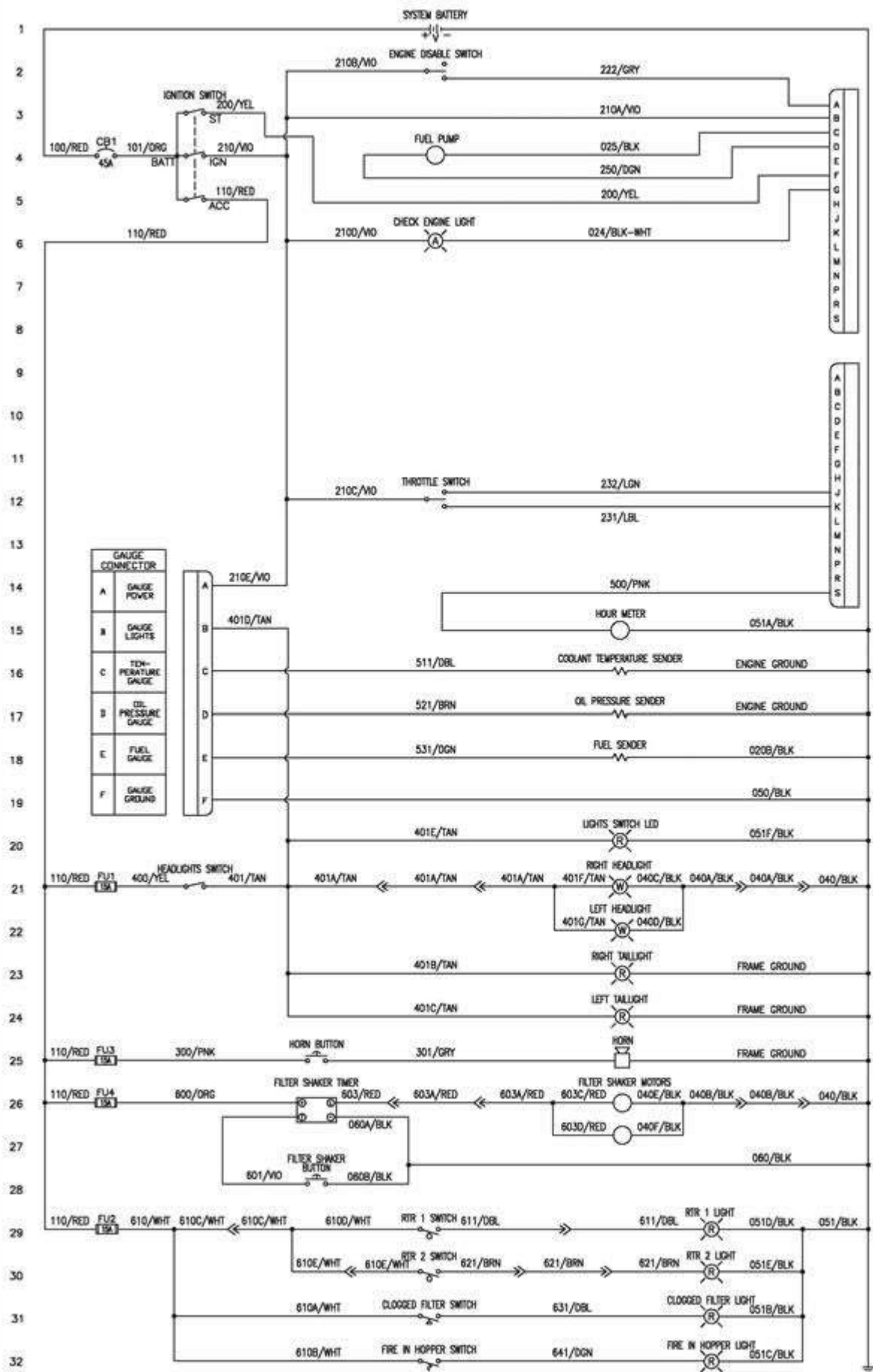

GAUGE CONNECTOR	
A	GAUGE POWER
B	GAUGE LIGHTS
C	TEMPERATURE GAUGE
D	OIL PRESSURE GAUGE
E	FUEL GAUGE
F	GAUGE GROUND



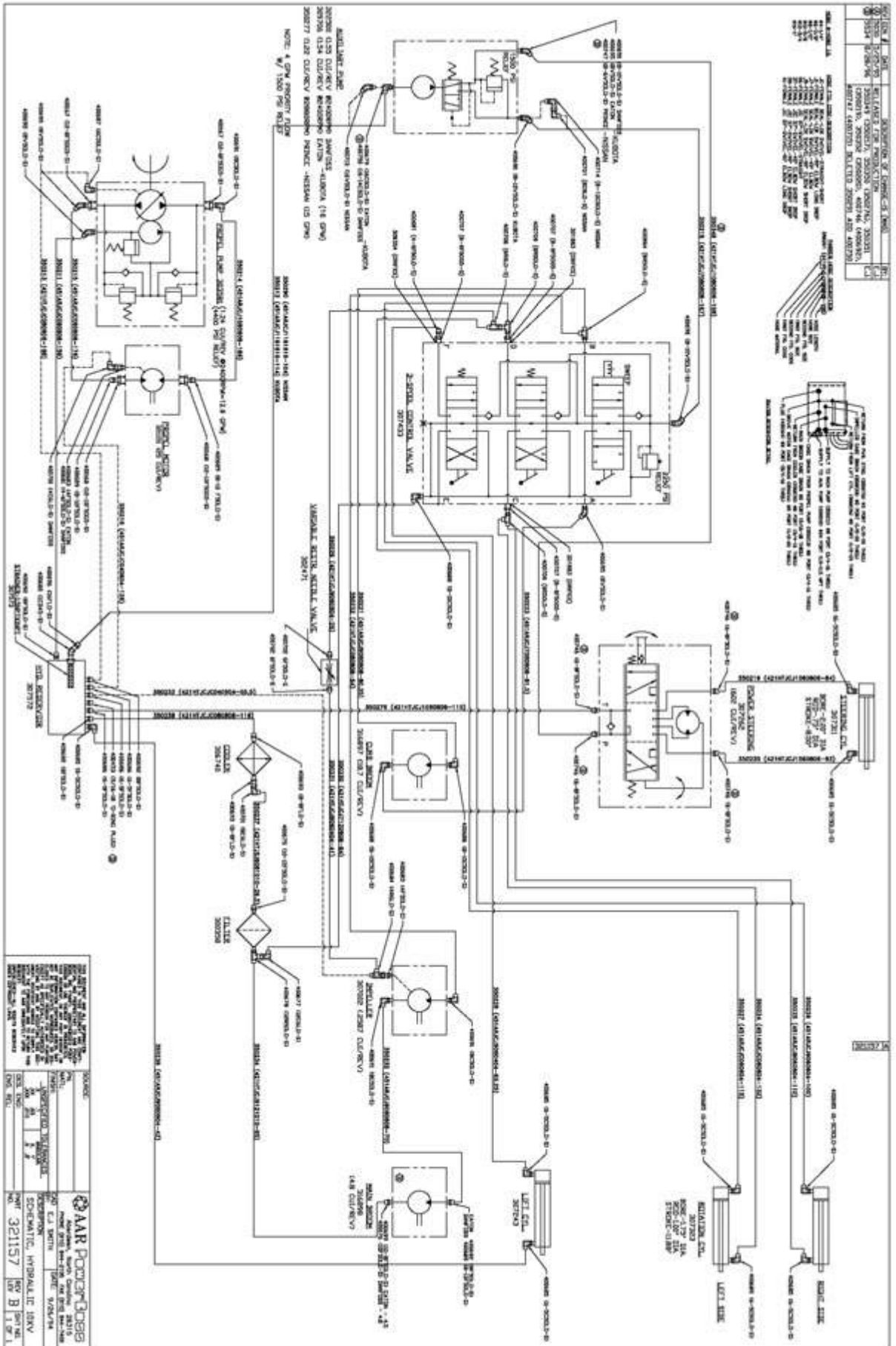

<p><b>ARR POWERBOSS</b>                  10000 W. Highway 100, Suite 100                  Dallas, TX 75243                  Phone: 972-261-1111                  Fax: 972-261-1112                  Email: sales@powerboss.com</p>	
<p>DATE: 10/1/01                  DRAWN: J. SMITH                  CHECKED: M. SMITH                  APPROVED: M. SMITH</p>	<p>NO. 321157                  REV B 1 OF 1</p>





***“The Power of Clean”***

**PowerBoss Is A Full Line Manufacturer Of Sweepers and Scrubbers For  
Industrial Facilities.**

PowerBoss, Inc 175 Anderson Street P.O. Box 1227- Aberdeen North Carolina 28315

Phone: 800-982-7141 - Fax: 1-800-277-7141 Local: 910-944-2105 Fax: 910-944-7409 e-mail: [techsupport@powerboss.com](mailto:techsupport@powerboss.com)

**A Member Of The Hako Group**