

# GROUP 00

# GENERAL

## CONTENTS

<b>HOW TO USE THIS MANUAL . . . . .</b>	<b>00-3</b>		
<b>TROUBLESHOOTING GUIDELINES</b>	<b>00-6</b>	HOW TO PERFORM VEHICLE IDENTIFICATION NUMBER (VIN) WRITING . . . . .	00-21
<b>HOW TO USE TROUBLESHOOTING/INSPECTION SERVICE POINTS . . . . .</b>	<b>00-6</b>	INITIALIZATION PROCEDURE FOR LEARNING VALUE IN MFI ENGINE . . . . .	00-22
TROUBLESHOOTING CONTENTS . . . . .	00-6	LEARNING PROCEDURE FOR IDLING IN MFI ENGINE . . . . .	00-23
HOW TO USE THE INSPECTION PROCEDURES . . . . .	00-8	SERVICING ELECTRICAL SYSTEM . . . . .	00-24
CONNECTOR MEASUREMENT SERVICE POINTS . . . . .	00-10	VEHICLE WASHING . . . . .	00-24
CONNECTOR INSPECTION SERVICE POINTS . . . . .	00-12	APPLICATION OF ANTI-CORROSION AGENTS AND UNDERCOATS . . . . .	00-24
HOW TO COPE WITH INTERMITTENT MALFUNCTIONS . . . . .	00-13	SCAN TOOL (MULTI USE TESTER { M.U.T.-III } SUB ASSEMBLY) . . . . .	00-25
INSPECTION SERVICE POINTS FOR A BLOWN FUSE . . . . .	00-15	<b>TOWING AND HOISTING . . . . .</b>	<b>00-26</b>
HOW TO TREAT CURRENT TROUBLE . . . . .	00-15	<b>GENERAL DATA AND SPECIFICATIONS . . . . .</b>	<b>00-29</b>
HOW TO TREAT PAST TROUBLE . . . . .	00-15	<b>TIGHTENING TORQUE . . . . .</b>	<b>00-30</b>
<b>VEHICLE IDENTIFICATION . . . . .</b>	<b>00-16</b>	<b>LUBRICATION AND MAINTENANCE</b>	<b>00-31</b>
VEHICLE IDENTIFICATION . . . . .	00-16	<b>RECOMMENDED LUBRICANTS AND LUBRICANT CAPACITIES TABLE . . . . .</b>	<b>00-33</b>
VEHICLE INFORMATION CODE PLATE . . . . .	00-17	<b>SCHEDULED MAINTENANCE TABLE</b>	<b>00-36</b>
<b>PRECAUTIONS BEFORE SERVICE.</b>	<b>00-21</b>		
SUPPLEMENTAL RESTRAINT SYSTEM (SRS) . . . . .	00-21		

Continued on next page

<b>MAINTENANCE SERVICE</b> . . . . .	<b>00-40</b>		
1. FUEL SYSTEM (TANK, PIPE LINE AND CONNECTION, AND FUEL TANK FILLER TUBE CAP) (CHECK FOR LEAKS) . . . . .	00-40	13. RESERVE TANK FOR ACD (CHECK FLUID LEVEL) . . . . .	00-47
2. FUEL HOSES (CHECK CONDITION) . . . . .	00-40	14. ENGINE COOLANT (CHANGE) . . . . .	00-48
3. AIR CLEANER ELEMENT (REPLACE) . . . . .	00-40	15. COOLANT HOSES (RADIATOR HOSE, HEATER HOSE) (INSPECT). . . . .	00-49
4. EVAPORATIVE EMISSION CONTROL SYSTEM (EXCEPT EVAPORATIVE EMISSION CANISTER) (CHECK FOR CLOGGING) . . . . .	00-40	16. DISC BRAKE PADS, ROTORS (INSPECT FOR WEAR) . . . . .	00-50
5. SPARK PLUGS (REPLACE). . . . .	00-41	17. BRAKE HOSES (CHECK FOR DETERIORATION OR LEAKS). . . . .	00-50
6. TIMING BELT (REPLACE) . . . . .	00-41	18. BALL JOINT AND STEERING LINKAGE SEALS (INSPECT FOR GREASE LEAKS AND DAMAGE) . . . . .	00-51
7. DRIVE BELT (FOR GENERATOR, WATER PUMP AND POWER STEERING OIL PUMP) (CHECK CONDITION) . . . . .	00-41	19. SUSPENSION SYSTEM (INSPECT FOR LOOSENESS AND DAMAGE) . . . . .	00-51
8. EXHAUST SYSTEM (CONNECTION PORTION OF MUFFLER, MUFFLER PIPES AND CONVERTER HEAT SHIELDS) (CHECK AND SERVICE). . . . .	00-43	20. DRIVESHAFT BOOTS (INSPECT FOR GREASE LEAKS AND DAMAGE). . . . .	00-51
9. ENGINE OIL (CHANGE). . . . .	00-43	21. REAR AXLE OIL (CHANGE). . . . .	00-51
10. ENGINE OIL FILTER (REPLACE) . . . . .	00-44	22. TIRES (ROTATE) . . . . .	00-52
11. MANUAL TRANSAXLE OIL . . . . .	00-45	23. AIR FILTER (REPLACE). . . . .	00-52
12. TRANSFER OIL . . . . .	00-46		
		<b>MAIN SEALANT AND ADHESIVE TABLE.</b> . . . . .	<b>00-53</b>

## HOW TO USE THIS MANUAL

M1001000101124

### MAINTENANCE, REPAIR AND SERVICING EXPLANATIONS

This manual provides explanations, etc. concerning procedures for the inspection, maintenance, repair and servicing of the subject model. Unless otherwise specified, each service procedure covers all models. Procedures covering specific models are identified by the model codes, or similar designation (engine type, transaxle type, etc.). A description of these designations is covered in this manual under "VEHICLE IDENTIFICATION."

### ON-VEHICLE SERVICE

The "ON-VEHICLE SERVICE" section has procedures for performing inspections and adjustments of particularly important components. These procedures are done with regard to maintenance and servicing, but other inspections (looseness, play, cracking, damage, etc.) must also be performed.

### SERVICE PROCEDURES

The service steps are arranged in numerical order. Attention to be paid in performing vehicle service are described in detail in SERVICE POINTS.

### DEFINITION OF TERMS

#### STANDARD VALUE

Indicates the value used as the standard for judging whether or not a part or adjustment is correct.

#### LIMIT

Shows the maximum or minimum value for judging whether or not a part or adjustment is acceptable.

#### REFERENCE VALUE

Indicates the adjustment value prior to starting the work (presented in order to facilitate assembly and adjustment procedures, and so they can be completed in a shorter time).

### DANGER, WARNING, AND CAUTION

DANGER, WARNING, and CAUTION call special attention to a necessary action or to an action that must be avoided. The differences among DANGER, WARNING, and CAUTION are as follows:

- If a DANGER is not followed, the result is severe bodily harm or even death.
- If a WARNING is not followed, the result could be bodily injury.
- If a CAUTION is not followed, the result could be damage to the vehicle, vehicle components or service equipment.

### TIGHTENING TORQUE INDICATION

The tightening torque indicates a median and its tolerance by a unit of N·m (in-lb) or N·m (ft-lb). For fasteners with no assigned torque value, refer to [P.00-30](#).

### SPECIAL TOOL NOTE

Only MMC special tool part numbers are called out in the repair sections of this manual. Please refer to the special tool cross-reference chart located at the beginning of each group, for the special tool number that is available in your market.

### ABBREVIATIONS

The following abbreviations are used in this manual for classification of model types:

M/T: Manual transaxle, or models equipped with manual transaxle.

MPI: Multipoint injection

DOHC: Engine with the double overhead camshaft

MIVEC: Mitsubishi Innovative Valve timing Electronic Control system

AWD: 4-wheel drive vehicles.

A/C: Air conditioning.

2.0L Engine: 2.0 liter <4G63> engine, or a model equipped with such an engine.

ECM: Engine control module

SWS: Simplified Wiring System

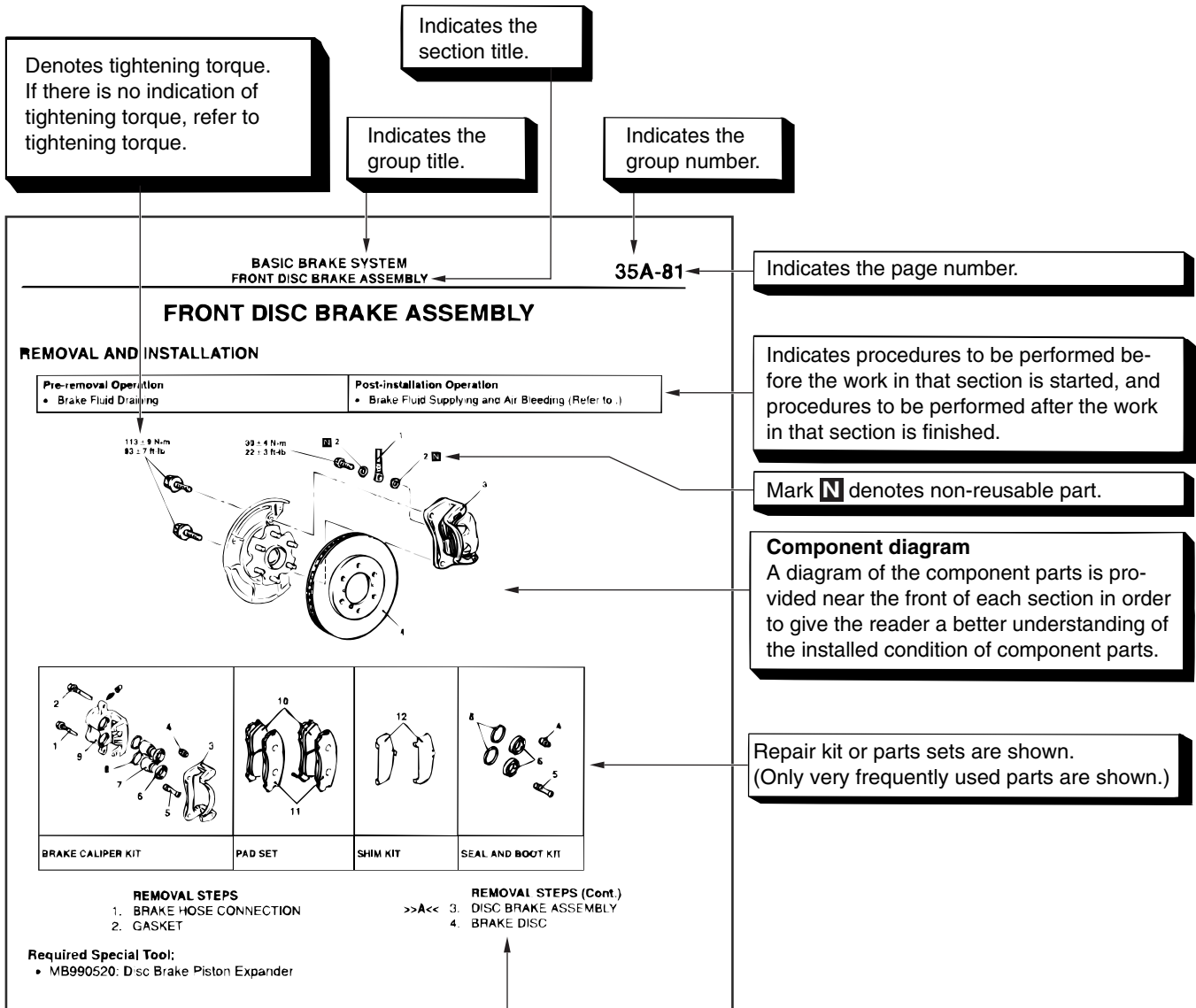

**Maintenance and servicing procedures**

The numbers provided within the diagram indicate the sequence for maintenance and servicing procedures.

- **Removal steps :**  
The part designation number corresponds to the number in the illustration to indicate removal steps.
- **Disassembly steps :**  
The part designation number corresponds to the number in the illustration to indicate disassembly steps.
- **Installation steps :**  
Specified in case installation is impossible in reverse order of removal steps. Omitted if installation is possible in reverse order of removal steps.
- **Assembly steps :**  
Specified in case installation is impossible in reverse order of removal steps. Omitted if assembly is possible in reverse order of disassembly steps.

**Classifications of major maintenance / service points**

When there are major points relative to maintenance and servicing procedures (such as essential maintenance and service points, maintenance and service standard values, information regarding the use of special tools, etc.). These are arranged together as major maintenance and service points and explained in detail.

<<A>> : Indicates that there are essential points for removal or disassembly.

>>A<< : Indicates that there are essential points for installation or assembly.

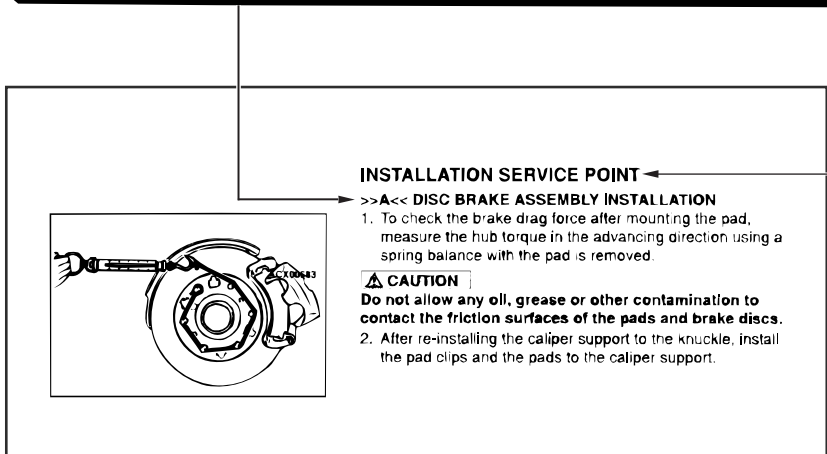

**INSTALLATION SERVICE POINT**

>>A<< DISC BRAKE ASSEMBLY INSTALLATION

1. To check the brake drag force after mounting the pad, measure the hub torque in the advancing direction using a spring balance with the pad is removed.

**CAUTION**  
Do not allow any oil, grease or other contamination to contact the friction surfaces of the pads and brake discs.

2. After re-installing the caliper support to the knuckle, install the pad clips and the pads to the caliper support.

Operating procedures, cautions, etc. on removal, installation, disassembly and assembly are described

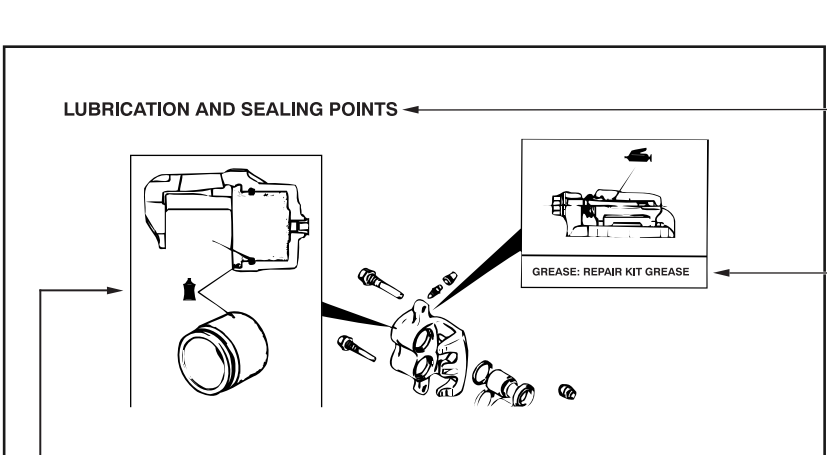

**LUBRICATION AND SEALING POINTS**





GREASE: REPAIR KIT GREASE

The title of the page (following the page on which the diagram of component parts is presented) indicating the locations of lubrication and sealing procedures.

Indicates (by symbols) where lubrication is necessary.

**Symbols for lubrication, sealants and adhesives**

Symbols are used to show the locations for lubrication and for application of sealants and adhesives. These symbols are included in the diagram of component parts or on the page following the component parts page. The symbols do not always have accompanying text to support that symbol.

-  : Grease (Multi-purpose grease unless there is a brand or type specified)
-  : Sealant or adhesive
-  : Brake fluid or automatic transmission fluid
-  : Engine oil, gear oil or air conditioning compressor oil
-  : Adhesive tape or butyl rubber tape

# TROUBLESHOOTING GUIDELINES

M1001008800328

## VERIFY THE COMPLAINT

- Make sure the customer's complaint and the service writer's work order description are understood before starting work.
- Make sure the correct operation of the system is understood. Read the service manual description to verify normal system operation.
- Operate the system to see the symptoms. Look for other symptoms that were not reported by the customer, or on the work order, that may be related to the problem.

## DETERMINE POSSIBLE CAUSES

Compare the confirmed symptoms to the diagnostic symptom indexes to find the right diagnosis procedure.

If the confirmed symptoms cannot be found on any symptom index, determine other possible causes.

- Analyze the system diagrams and list all possible causes for the problem symptoms.
- Rank all these possible causes in order of probability, based on how much of the system they cover, how likely they are to be the cause, and how easy they will be to check. Be sure to take experience into account. Consider the causes of similar problems seen in the past. The list of causes should be ranked in order from general to specific, from most-likely to least-likely, and from easy-to-check to hard-to-check.

## FIND THE PROBLEM

After the symptoms have been confirmed, and probable causes have been identified, the next step is to make step-by-step checks of the suspected system components, junctions, and links in logical order.

Use the diagnostic procedures in the service manual whenever possible. Follow these procedures carefully to avoid missing an important step in the diagnosis sequence. It might be the skipped step that leads to the solution of the problem.

If the service manual doesn't have step-by-step procedures to help diagnose the problem, make a series of checks based on the ranked list of probable causes. Troubleshooting checks should be made in the order that the list of causes was ranked:

- general to specific
- most-likely to least-likely
- easy-to-check to hard-to-check

## REPAIR THE PROBLEM

When the step-by-step troubleshooting checks find a fault, perform the proper repairs. Make sure to fix the root cause of the problem, not just the symptom. Just fixing the symptom, without fixing the root cause, will cause the symptom to eventually return.

## VERIFY THE REPAIR

After repairs are made, recheck the operation of the system to confirm that the problem is eliminated. Be sure to check the system thoroughly. Sometimes new problems are revealed after repairs have been made.

# HOW TO USE TROUBLESHOOTING/INSPECTION SERVICE POINTS

## TROUBLESHOOTING CONTENTS

### CAUTION

- During diagnosis, a DTC code associated with other system may be set when the ignition switch is turned on with connector(s) disconnected. On completion, confirm all systems for DTC code(s). If DTC code(s) are set, erase them all.
- When the M.U.T.-III detects a diagnostic trouble code, its display informs users whether a mechanical problem currently exists ("current trouble") or whether it existed before but normal operation has been restored ("past trou-

ble"). However, if an MFI, TPMS or SRS airbag-related DTC is set, "Active DTC/Stored DTC" is not displayed. In this case, follow the diagnosis procedure for current trouble.

Troubleshooting of electronic control systems for which the scan tool can be used follows the basic outline described below. Even in systems for which the scan tool cannot be used, part of these systems still follow this outline.

M1001013300288

## 1. STANDARD FLOW OF DIAGNOSTIC TROUBLESHOOTING

Troubleshooting strategy is shown in each group.

## 2. SYSTEM OPERATION AND SYMPTOM VERIFICATION TESTS

If verification of the symptom(s) is difficult, procedures for checking operation and verifying symptoms are shown.

## 3. DIAGNOSTIC FUNCTION

The following trouble code diagnoses are shown.

- How to read diagnostic trouble codes
- How to erase diagnostic trouble codes
- Input inspection service points

## 4. DIAGNOSTIC TROUBLE CODE CHART

If the scan tool displays a diagnostic trouble code, find the applicable inspection procedure according to this chart.

## 5. SYMPTOM CHART

If there are symptoms, even though the scan tools show that no DTCs are set, inspection procedures for each symptom will be found by using this chart.

## 6. DIAGNOSTIC TROUBLE CODE PROCEDURES

Indicates the inspection procedures corresponding to each diagnostic trouble code. (Refer to [P.00-8](#)).

## 7. SYMPTOM PROCEDURES

Indicates the inspection procedures corresponding to each symptom listed in the Symptom Chart (Refer to [P.00-8](#)).

## 8. DATA LIST REFERENCE TABLE

Inspection items and normal judgment values have been provided in this chart as reference information.

## 9. CHECK AT ECU TERMINALS

Terminal numbers for the ECU connectors, inspection items, and standard values have been provided in this chart as reference information.

## TERMINAL VOLTAGE CHECKS

1. Connect a needle-nosed wire probe to a voltmeter probe.

### CAUTION

**Short-circuiting the positive (+) probe between a connector terminal and ground could damage the vehicle wiring, the sensor, the ECU, or all three. Use care to prevent this!**

2. Insert the needle-nosed wire probe into each of the ECU connector terminals from the wire side, and measure the voltage while referring to the check chart.

*NOTE: Measure voltage with the ECU connectors connected.*

*You may find it convenient to pull out the ECU to make it easier to reach the connector terminals. Checks don't have to be carried out in the order given in the chart.*

3. If voltage readings differ from normal condition values, check related sensors, actuators, and wiring. Replace or repair as needed.
4. After repair or replacement, recheck with the voltmeter to confirm that the repair has corrected the problem.

## TERMINAL RESISTANCE AND CONTINUITY CHECKS

1. Turn the ignition switch to the "LOCK" (OFF) position.
2. Disconnect the ECU connector.

### CAUTION

**If resistance and continuity checks are performed on the wrong terminals, damage to the vehicle wiring, sensors, ECU, and/or ohmmeter may occur. Use care to prevent this!**

3. Measure the resistance and check for continuity between the terminals of the ECU harness-side connector while referring to the check chart.

*NOTE: Checks don't have to be carried out in the order given in the chart.*

4. If the ohmmeter shows any deviation from the Normal Condition value, check the corresponding sensor, actuator and related electrical wiring, then repair or replace.
5. After repair or replacement, recheck with the ohmmeter to confirm that the repair has corrected the problem.

## 10. INSPECTION PROCEDURES USING AN OSCILLOSCOPE

When there are inspection procedures using an oscilloscope, these are listed.

HOW TO USE THE INSPECTION PROCEDURES

The causes of many of the problems occurring in electric circuitry are generally the connectors, components, the ECU, and the harnesses between connectors, in that order. These inspection procedures follow this order. They first try to discover a problem with a connector or a defective component.

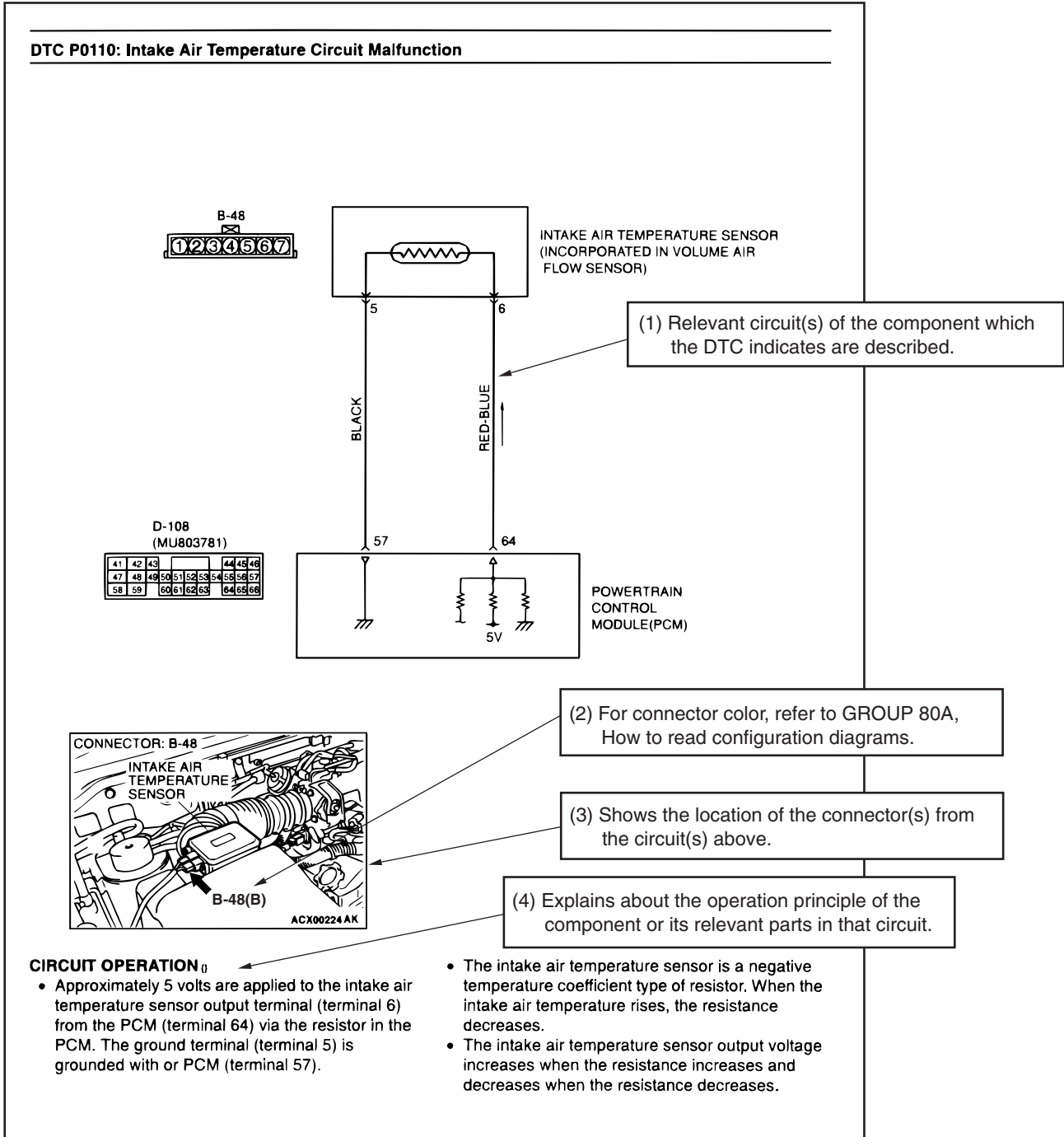

ACX00861AE



(5) Explains about technical details.

**TECHNICAL DESCRIPTION**

- The engine coolant temperature sensor converts the engine coolant temperature to a voltage and output it.

**DTC SET CONDITIONS**

**Check Conditions**

- Engine coolant temperature was 7°C (45°F) or more immediately before the engine was stopped at the last drive.

(6) Describes the conditions for that DTC being set (stored).

- The PCM checks whether this voltage is within a specified range.

(7) Describes possible cause(s) for that DTC.

**TROUBLESHOOTING HINTS (The most likely causes for this code to be set are: )**

- Engine coolant temperature sensor failed.
- Open or shorted engine coolant temperature sensor circuit, or loose connector.
- PCM failed.

(8) Start of the diagnosis procedure for that DTC.

**DIAGNOSIS**

**Required Special Tool:**

- MB991958: Scan Tool (M.U.T.-III Sub Assembly)
  - MB991824: V.C.I.
  - MB991827: USB Cable
  - MB991910: Main Harness A

(9) Identifies the special tool(s) necessary for diagnosing that DTC.

**STEP 1. Using scan tool MB991958, check data list item 15: Transmission Fluid Temperature Sensor.**

**CAUTION**  
 To prevent damage to scan tool MB991958, always turn the ignition switch to the "LOCK" (OFF) position before connecting or disconnecting scan tool MB991958.

- Connect scan tool MB991958 to the data link connector.
- Start the engine.
- Set scan tool MB991958 to the data reading mode for item 15, Transmission Fluid Temperature Sensor.
  - When the engine is cool: Almost equal to the ambient temperature (atmospheric temperature)
- Turn the ignition switch to the "LOCK" (OFF) position.

**NOTE:** Set scan tool MB991958 to data reading mode for item number 13, Intake Air Temperature (IAT) Sensor and note the temperature measurement. When the engine is cool, the temperature should be almost equal to the ambient temperature (atmospheric temperature), and the IAT sensor measurement should be approximately the same as the Transmission Fluid Temperature Sensor.

- When the engine is warm: 70 to 80°C (158 to 176°F)

**Q: Is the sensor operating properly?**

**YES :** It can be assumed that this malfunction is intermittent. Refer to GROUP 00, How to Use Troubleshooting/ Inspection Service Points – How to Cope with Intermittent Malfunction .

**NO :** Go to Step 2.

(10) Provides the inspection procedure for that DTC step by step.

AC210616AB

**CURRENT TROUBLE**

Indicates that the trouble is currently present. Carry out troubleshooting as described in the applicable inspection procedure.

**PAST TROUBLE**

Indicates that the status is "Stored" and the trouble is historic. Since the trouble may still be present, set the vehicle to the diagnosis code detection condition and check that the status changes to "Active". If the status does not change from "Stored", observe the applicable inspection procedure with particular emphasis on connector(s) and wiring harness.

**HARNESS INSPECTION**

Check for an open or short circuit in the harness between the terminals which were faulty according to the connector measurements. Carry out this inspection while referring to GROUP 00E, Harness Connector Inspection P.00E-2. Here, "Check harness between power supply and terminal xx" also includes checking for blown fuse. For inspection service points when there is a blown fuse, refer to "Inspection Service Points for a Blown Fuse P.00-15."

**MEASURES TO TAKE AFTER REPLACING THE ECM OR ECU**

If the trouble symptoms have not disappeared even after replacing the ECM or ECU, repeat the inspection procedure from the beginning.

**CONNECTOR MEASUREMENT SERVICE POINTS**

M1001013600320

Turn the ignition switch to the "LOCK" (OFF) position when connecting and disconnecting the connectors. Turn the ignition switch to "ON" when measuring, unless there are instructions to the contrary.

**IF INSPECTING WITH THE CONNECTOR CONNECTED <WATERPROOF CONNECTORS>**

Be sure to use special tool. Never insert a test probe from the harness side, as this will reduce the waterproof performance and result in corrosion.

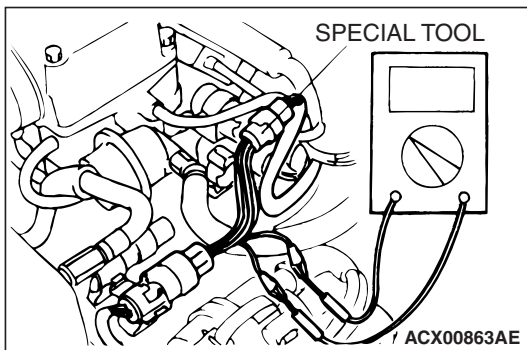
**IF INSPECTING WITH THE CONNECTOR CONNECTED <ORDINARY (NON-WATERPROOF) CONNECTORS>**

Inspect by inserting a test probe from the harness side. If the connector is too small to insert a test probe (e.g. control unit connector), do not insert it forcibly. Use special tool extra fine probe (MB992006).

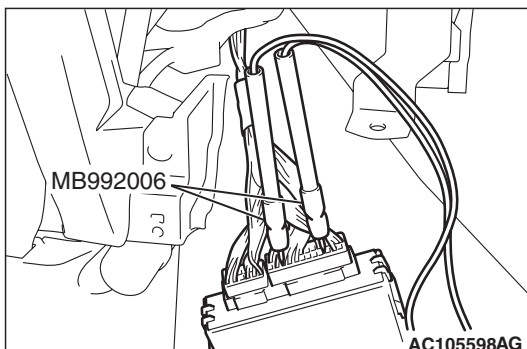

### IF INSPECTING WITH THE CONNECTOR DISCONNECTED <WHEN INSPECTING A FEMALE PIN>

#### Required Special Tool:

- MB991219: Inspection Harness (Included in MB991223, Harness Set)
- The special tool MB991219 for connector pin contact pressure should be used. The test probe should never be forcibly inserted, as it may cause a defective contact.

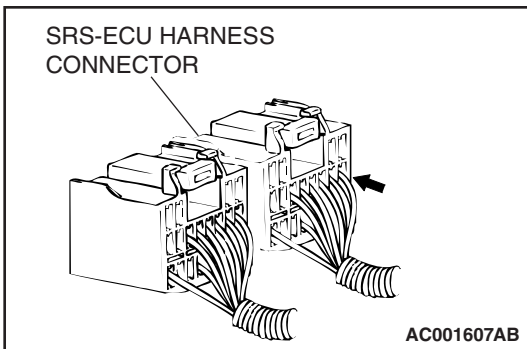
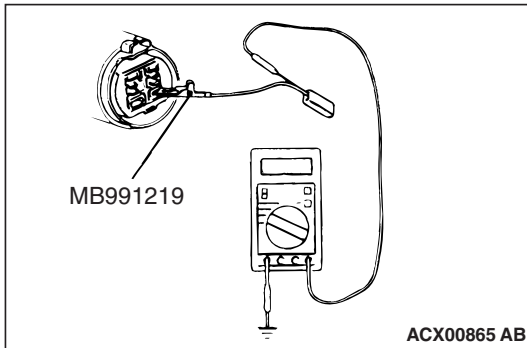

- From back side of the connector (SRS-ECU harness side connector)
- Since the SRS-ECU harness connector is plated to improve conductivity, observe the warning below when checking this connector.

#### **⚠ WARNING**

***Insert the backprobing tool into the connector from the harness side, and connect the tester to the backprobing tool. If any tool other than the backprobing tool is used, it may cause damage to the harness and other components. Furthermore, measurement should not be carried out by touching the backprobing tool directly against the terminals from the front of the connector. The terminals are plated to increase their conductivity, so that if they are touched directly by the backprobing tool, the plating may break, which will decrease reliability.***

### IF INSPECTING WITH THE CONNECTOR DISCONNECTED <WHEN INSPECTING A MALE PIN>

#### **⚠ CAUTION**

**At this time, be careful not to short the connector pins with the test probes. Doing so may damage the circuits inside the ECU.**

Touch the pin directly with the test probe.

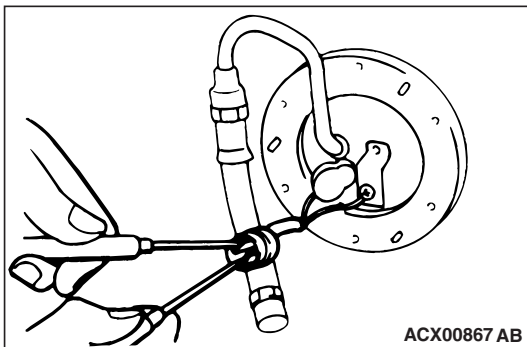

**CONNECTOR INSPECTION SERVICE POINTS**

M1001013700112

**VISUAL INSPECTION**

- Connector is disconnected or improperly connected
- Connector pins are pulled out
- Stretched or broken wires at terminal section
- Low contact pressure between male and female terminals
- Low connection pressure due to rusted terminals or foreign matter lodged in terminals

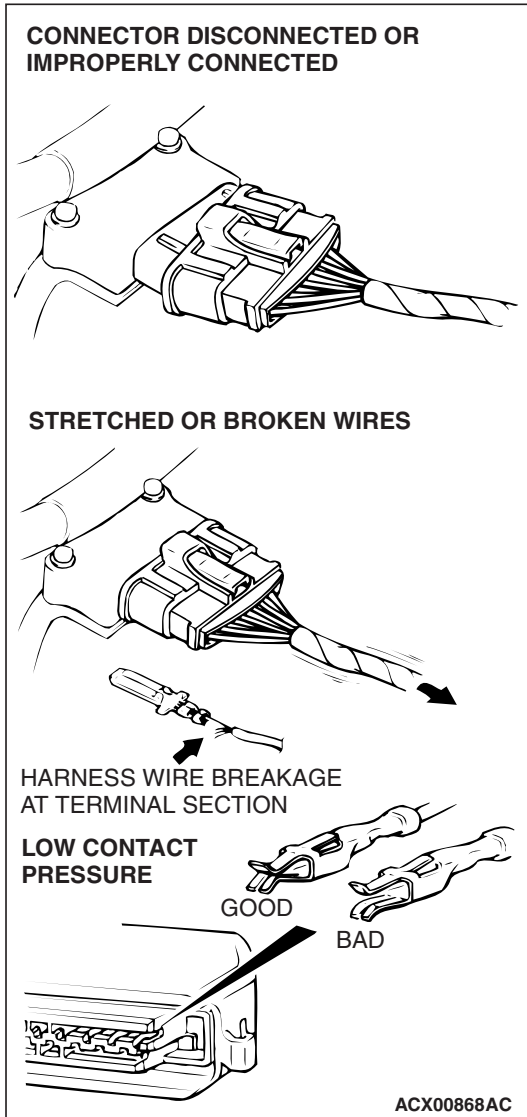
**CONNECTOR PIN INSPECTION**

If the connector pin stopper is damaged, the terminal connections (male and female pins) will not be perfect even when the connector body is connected, because the pins may pull out of the back side of the connector. Therefore, gently pull the wires one by one to make sure that no pins pull out of the connector.

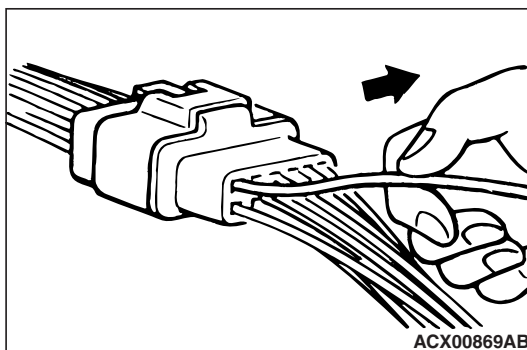

## CONNECTOR ENGAGEMENT INSPECTION

### Required Special Tool:

- MB991219: Inspection Harness (contained in MB991223 Test Harness)

Use special tool MB991219 to inspect the engagement of the male pins and female pins. [Pin drawing force: 1 N (0.2 pound) or more]

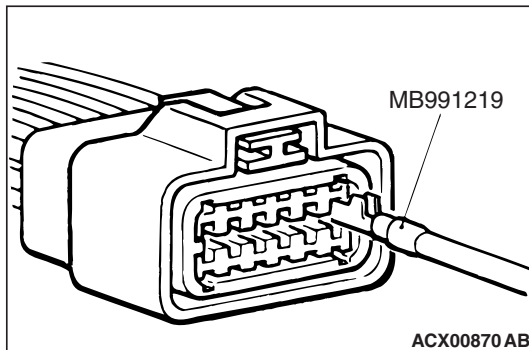

## HOW TO COPE WITH INTERMITTENT MALFUNCTIONS

M1001013900116

Most intermittent malfunctions occur under certain conditions. If those conditions can be identified, the cause will be easier to find.

### TO COPE WITH INTERMITTENT MALFUNCTION; 1. ASK THE CUSTOMER ABOUT THE MALFUNCTION

Ask what it feels like, what it sounds like, etc. Then ask about driving conditions, weather, frequency of occurrence, and so on.

### 2. DETERMINE THE CONDITIONS FROM THE CUSTOMER'S RESPONSES

Typically, almost all intermittent malfunctions occur from conditions like vibration, temperature and/or moisture change, poor connections. From the customer's responses, it should be reasoned which condition is most likely.

### 3. USE SIMULATION TEST

Use the simulation tests below to attempt to duplicate the customer's complaint. Determine the most likely circuit(s) and perform the simulation tests on the connectors and parts of that circuit(s). Be sure to use the inspection procedures provided for diagnostic trouble codes and trouble symptoms.

For temperature and/or moisture condition related intermittent malfunctions, try to change the conditions of the suspected circuit components, then use the simulation tests below.

#### 4. VERIFY THE INTERMITTENT MALFUNCTION IS ELIMINATED

Repair the malfunctioning part and try to duplicate the condition(s) again to verify the intermittent malfunction has been eliminated.

#### SIMULATION TESTS

*NOTE: In case of difficulty in finding the cause of the intermittent malfunction, the data recorder function in the scan tool is effective.*

For these simulation tests, shake, then gently bend, pull, and twist the wiring of each of these examples to duplicate the intermittent malfunction.

- Shake the connector up-and-down, and right-and-left.
- Shake the wiring harness up-and-down, and right-and-left. Especially, check the splice points of wiring harnesses carefully. Refer to GROUP 00E, Harness Connector Inspection [P.00E-2](#).
- Shake the part or sensor.

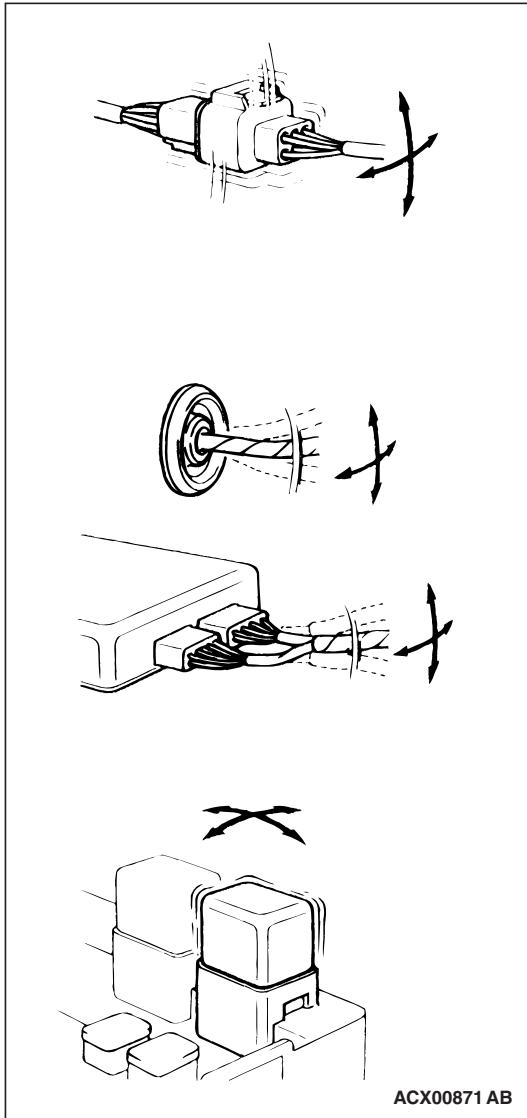

## INSPECTION SERVICE POINTS FOR A BLOWN FUSE

M1001013800119

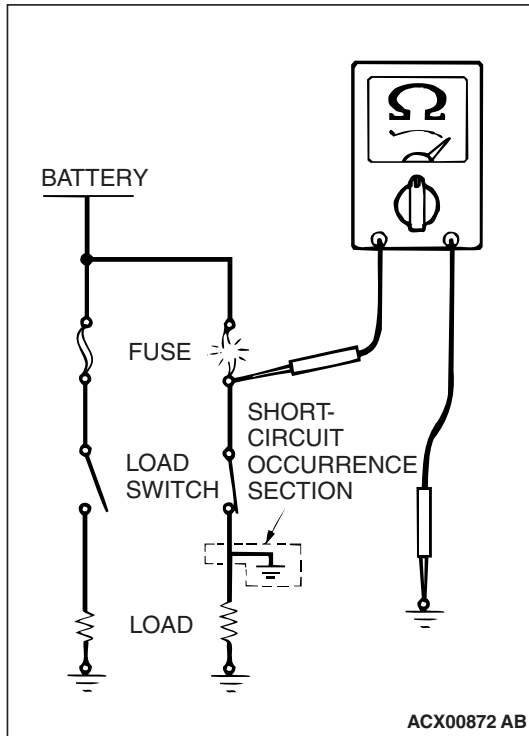

Remove the blown fuse and measure the resistance between the load side of the blown fuse and the ground. Close the switches of all circuits which are connected to this fuse. If the resistance is almost  $0 \Omega$  at this time, there is a short somewhere between these switches and the load. If the resistance is not  $0 \Omega$ , there is no short at the present time, but a momentary short has probably caused the fuse to blow.

The main causes of a short circuit are the following.

- Harness being clamped by the vehicle body
- Damage to the outer casing of the harness due to wear or heat
- Water getting into the connector or circuitry
- Human error (mistakenly shorting a circuit, etc).

## HOW TO TREAT CURRENT TROUBLE

M1001014000042

1. Make a note of the diagnostic trouble code, and erase it.
2. Check the trouble symptom again.
3. Check for diagnostic trouble codes again.
4. If a diagnostic trouble code is set, follow the applicable Diagnostic Trouble Code Chart.
5. If no diagnostic trouble code is set, refer to "How to Cope with Intermittent Malfunction P.00-13."

## HOW TO TREAT PAST TROUBLE

M1001014100209

Since the trouble may still be present even the status is "Stored", set the vehicle to the diagnosis code detection condition and check that the status changes to "Active". If the status does not change from "Stored", carry out the following procedure.

1. Establish from the customer whether a fuse or connector has been replaced or disconnected.
2. If yes, erase the diagnosis code, and then check that no diagnostic code is reset. If no diagnosis code is reset, the diagnosis is complete.
3. If no, follow the applicable Diagnostic Trouble Code Chart. Then check the wiring harness and connector, and refer to "How to Cope with Intermittent Malfunction P.00-13."

**VEHICLE IDENTIFICATION****VEHICLE IDENTIFICATION**

M1001000401244

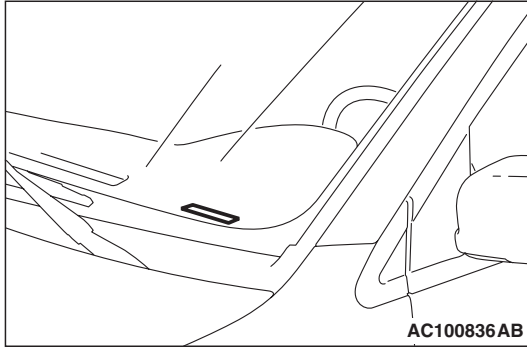
**VEHICLES IDENTIFICATION NUMBER LOCATION**

The vehicle identification number (VIN) is located on a plate attached to the left top side of the instrument panel.

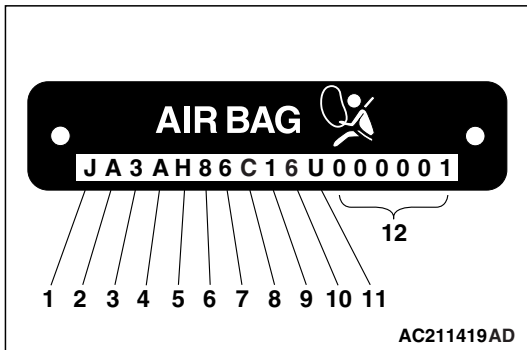
**VEHICLE IDENTIFICATION CODE CHART PLATE**

All vehicle identification numbers contain 17 digits. The vehicle number is a code which tells country, make, vehicle type, etc.

NO.	ITEM	CONTENT	
1	Country	J	Japan
2	Make	A	Mitsubishi
3	Vehicle type	3	Passenger car
4	Others	A	Driver and passenger air bags
5	Line	H	LANCER AWD
6	Price class	3	Medium
		8	Sports
7	Body	6	4-door sedan
8	Engine	C	2.0L DOHC-Intercooler Turbocharger (4G63) MIVEC
9	Check digits*	-	0, 1, 2, 3, -----9, X
10	Model year	6	2006 year
11	Plant	U	Mizushima
12	Serial number	-	000001 to 999999

**NOTE:** \*: Check digit means a singles number or letter X used to verify the accuracy of transcription of vehicle identification number.



**VEHICLE IDENTIFICATION NUMBER LIST**

**VEHICLES FOR FEDERAL EMISSION REGULATION**

VIN (EXCEPT SEQUENCE NUMBER)	BRAND		ENGINE DISPLACEMENT	MODEL CODE
JA3AH36C_6U	MITSUBISHI LANCER EVOLUTION-IX	RS	2.0L Intercooler Turbocharger	CT9ASNDFZL2M
JA3AH86C_6U		GSR		CT9ASNGFZL2M
JA3AH86C_6U				CT9ASJGFZL2M

**VEHICLE INFORMATION CODE PLATE**

M1001005400893

The vehicle information code plate is riveted onto the engine hood in the engine compartment. The plate shows model code, engine model, transaxle model and body color code.

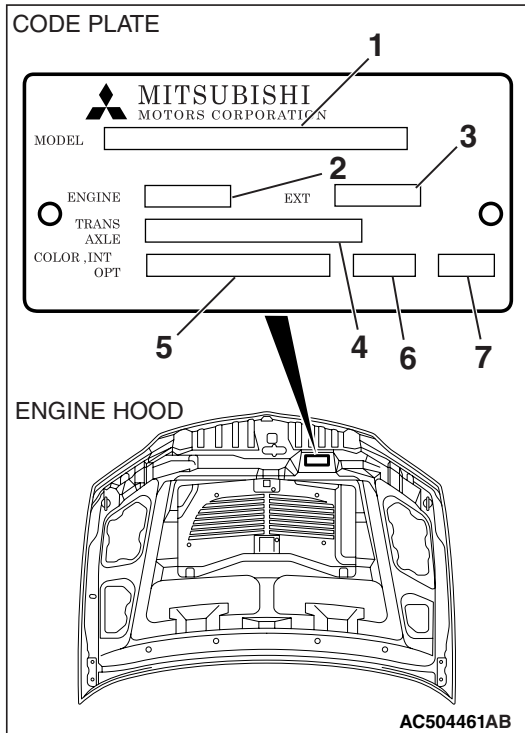

NO.	ITEM	CONTENT	
1	MODEL	CT9ASNGF ZL2M	CT9AS: Vehicle model
			NGFZL2M: Model series
2	ENGINE	4G63	Engine model
3	EXT	ZZZ	Exterior code
4	TRANS AXLE	W5M51	Transaxle model
5	COLOR	W83	Body color code
6	INT	33X	Interior code
7	OPT	N22	Equipment code

For monotone color vehicles, the body color code shall be indicated.

**VEHICLE SAFETY CERTIFICATION LABEL**

The vehicle safety certification label is attached to the face of the left door sill.

This label indicates the month and year of manufacture, Gross Vehicle Weight Rating (GVWR), front and rear Gross Axle Weight Rating (GAWR), and Vehicle Identification Number (VIN).

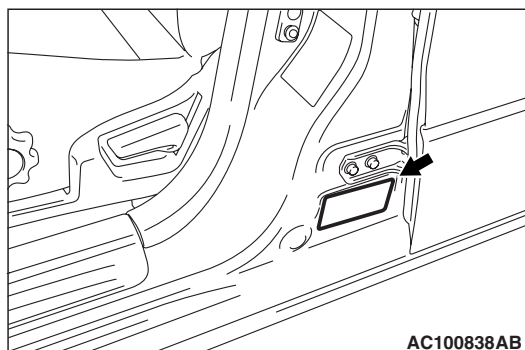

**TIRE AND LOADING INFORMATION PLACARD**

The tire and loading information placard is located on the inside sill of the driver's door.

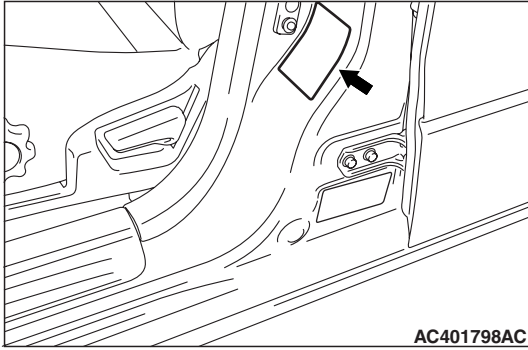

AC401798AC

**ENGINE MODEL STAMPING**

The engine model is stamped on the cylinder block. These engine model number are as shown as follows.

ENGINE MODEL	ENGINE DISPLACEMENT
4G63	2.0L

The engine serial number is stamped near the engine model number.

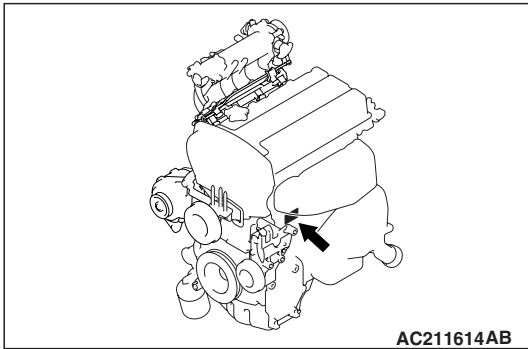

AC211614AB

**THEFT PROTECTION PLATE, LABEL OR STAMP**

A: FOR ORIGINAL PARTS

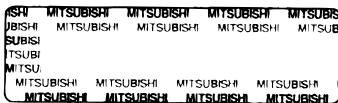

B: FOR REPLACEMENT PARTS



AC101015AE

**THEFT PROTECTION**

In order to protect against theft, a Vehicle Identification Number (VIN) is attached as a plate or label to the following major parts of the engine and transaxle, as well as main outer panels: Engine cylinder block, Transaxle housing, Fender, Doors, lift-gate, Quarter panel, Hood, Bumpers  
In addition, a theft-protection label is attached to replacement parts for the body outer panel main components, and the same data is stamped into replacement parts for the engine and the transaxle.

**CAUTION**

When replacing a part that has the theft protection plate, label or stamp on it, be sure that the part has either A or B shown in the figure. It is illegal if both A and B are attached, or neither A nor B is attached.

**⚠ CAUTION**

Cautions regarding panel repairs:

1. When repainting original parts, do so after first masking the theft-protection label. After painting, be sure to peel off the masking tape.
2. The theft-protection label for replacement parts is covered by masking tape, so such parts can be painted as is. The masking tape should be removed after painting is finished.
3. The theft-protection label should not be removed from original parts or replacement parts.

LOCATIONS

**LABEL AREA (A: FOR ORIGINAL EQUIPMENT PARTS, B: FOR REPLACEMENT PARTS)**

ENGINE

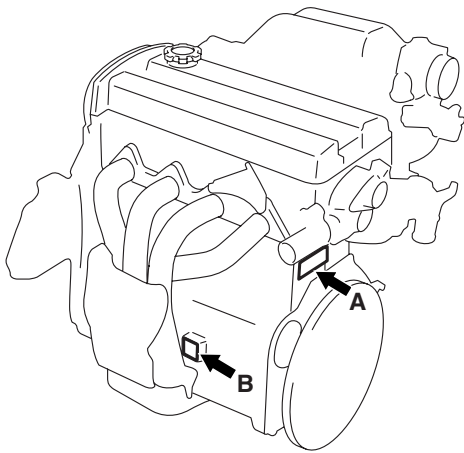

AC211574 AB

MANUAL TRANSAXLE

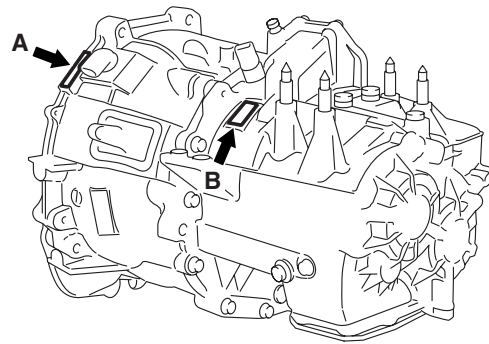

AC211575 AB

FENDER

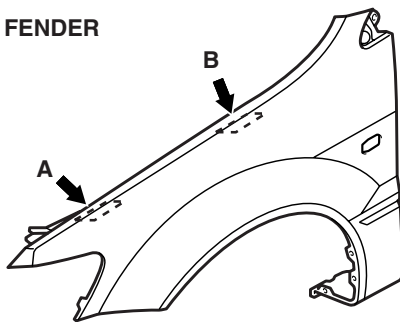

AC101605 AB

THE ILLUSTRATION INDICATES LEFT OUTER SIDE. RIGHT SIDE IS SYMMETRICALLY OPPOSITE.

QUARTER PANEL OUTER

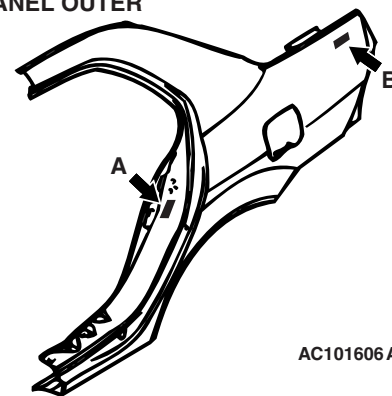

AC101606 AB

THE ILLUSTRATION INDICATES LEFT OUTER SIDE. RIGHT SIDE IS SYMMETRICALLY OPPOSITE.

**LABEL AREA (A: FOR ORIGINAL EQUIPMENT PARTS, B: FOR REPLACEMENT PARTS)**

**FRONT DOOR**

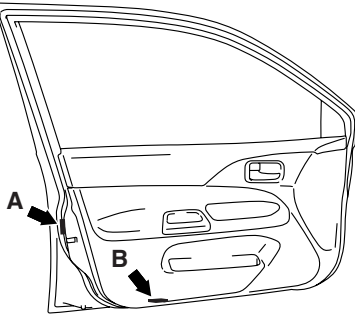

THE ILLUSTRATION INDICATES LEFT INNER SIDE.  
RIGHT SIDE IS SYMMETRICALLY OPPOSITE.

AC101607AB

**REAR DOOR**

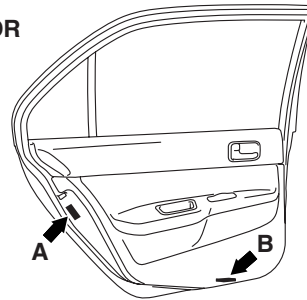

THE ILLUSTRATION INDICATES LEFT INNER SIDE.  
RIGHT SIDE IS SYMMETRICALLY OPPOSITE.

AC101608AB

**HOOD**

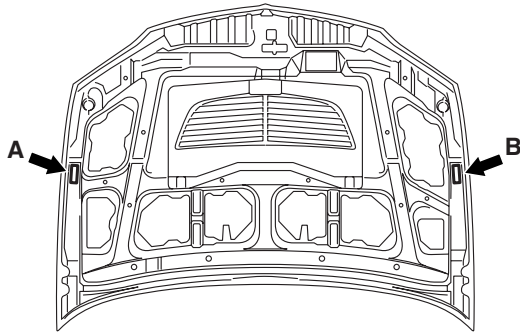

AC211576AB

**TRUNK LID**

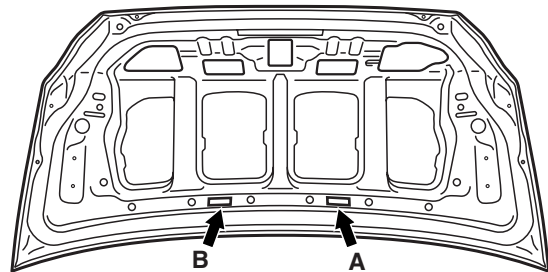

AC212032 AB

**FRONT BUMPER**

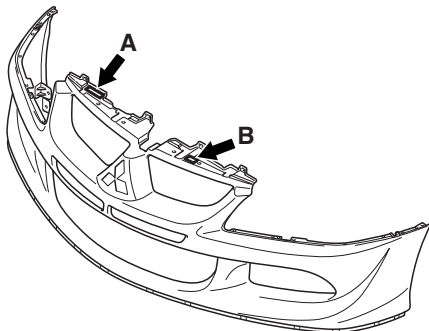

AC211577AB

**REAR BUMPER**

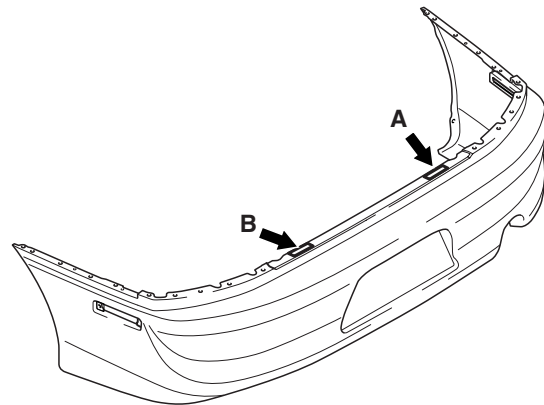

AC211578AB

## PRECAUTIONS BEFORE SERVICE

### SUPPLEMENTAL RESTRAINT SYSTEM (SRS)

M1001011600313

1. Items to review when servicing SRS
  - (1) Be sure to read GROUP 52B, Supplemental Restraint System (SRS). For safe operation, please follow the directions and heed all warnings.
  - (2) Wait at least 60 seconds after disconnecting the battery cable before doing any further work. The SRS system is designed to retain enough voltage to deploy the air bag even after the battery has been disconnected. Serious injury may result from unintended air bag deployment if work is done on the SRS system immediately after the battery cable is disconnected.
  - (3) Warning labels must be heeded when servicing or handling SRS components. Warning labels can be found in the following locations.
    - Hood
    - Front impact sensor
    - Sun visor
    - SRS-ECU
    - Steering wheel
    - Clock spring
    - Joint cover
    - Air bag module (Driver's and front passenger's)
    - Seat belt pre-tensioner
  - (4) Always use the designated special tools and test equipment.
  - (5) Store components removed from the SRS in a clean and dry place. The air bag module should be stored on a flat surface and placed so that the pad surface is facing upward.
  - (6) Never attempt to disassemble or repair the SRS components (SRS-ECU, air bag module, clock spring and seat belt pre-tensioner). If there is a defect, replace the defective part.
  - (7) Whenever you finish servicing the SRS, check the SRS warning light operation to make sure that the system functions properly.
  - (8) Be sure to deploy the air bag before disposing of the air bag module or disposing of a vehicle equipped with an air bag. (Refer to GROUP 52B, Air Bag Module Disposal Procedures P.52B-180.)
2. Observe the following when carrying out operations on places where SRS components are installed, including operations not directly related to the SRS air bag.
  - (1) When removing or installing parts, do not allow any impact or shock to occur to the SRS components.
  - (2) If heat damage may occur during paint work, remove the SRS components. After re-installing them, check the SRS warning light operation to make sure that the system functions properly.
  - SRS-ECU, air bag module, clock spring: 93° C (200° F) or more
  - Seat belt pre-tensioner: 90° C (194° F) or more

### HOW TO PERFORM VEHICLE IDENTIFICATION NUMBER (VIN) WRITING

M1001011400289

The Vehicle Identification Number (VIN) is stored in the ECM by the vehicle manufacture. If the VIN to be stored in the ECM is eliminated fraudulently, the Malfunction Indicator Lamp (SERVICE ENGINE SOON) illuminates and Diagnostic Trouble Code (DTC) No. P0630 (VIN malfunction) is shown. When the ECM is replaced, and entry of the VIN necessary due to DTC No. P0630 (VIN malfunction). Enter the VIN in accordance with the procedure as follows:

### WRITING PROCEDURE

#### Required Special Tools:

- MB991958: Scan Tool (M.U.T.-III Sub Assembly)
  - MB991824: V.C.I.
  - MB991827: USB Cable
  - MB991911: Main Harness B

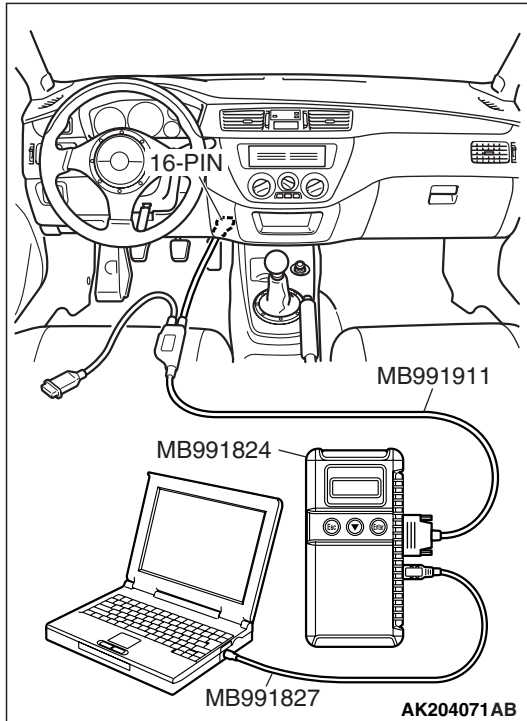
**⚠ CAUTION**

To prevent damage to scan tool MB991958, always turn the ignition switch to the "LOCK" (OFF) position before connecting or disconnecting scan tool MB991958.

1. Connect scan tool MB991958 to the data link connector.
2. Turn the ignition switch to the "ON" position.
3. Confirm DTC No. P0603 (EEPROM malfunction) is not shown.

*NOTE: When DTC No. P0603 (EEPROM malfunction) is shown, the VIN cannot be stored even if entered. Therefore, the troubleshooting is performed when this DTC is shown.*

4. Select "Coding" form the menu screen.
5. Select "VIN writing" form the menu screen.
6. Enter the VIN.
7. After entry of the VIN, turn the ignition switch to the "LOCK" (OFF) position. After ten seconds or more passed, turn to the "ON" position again.

8. Confirm DTC No. P0630 (VIN malfunction) is not shown.

*NOTE: When DTC No. P0630 (VIN malfunction) is shown, enter the VIN again because that would be not appropriate.*

## INITIALIZATION PROCEDURE FOR LEARNING VALUE IN MFI ENGINE

M1001011700354

When the following service is performed, initialize the learning value.

- At replacing engine assembly
- At replacing throttle body and at cleaning
- At replacing knock sensor

## INITIALIZATION PROCEDURE

### Required Special Tools:

- MB991958: Scan Tool (M.U.T.-III Sub Assembly)
  - MB991824: V.C.I.
  - MB991827: USB Cable
  - MB991911: Main Harness B

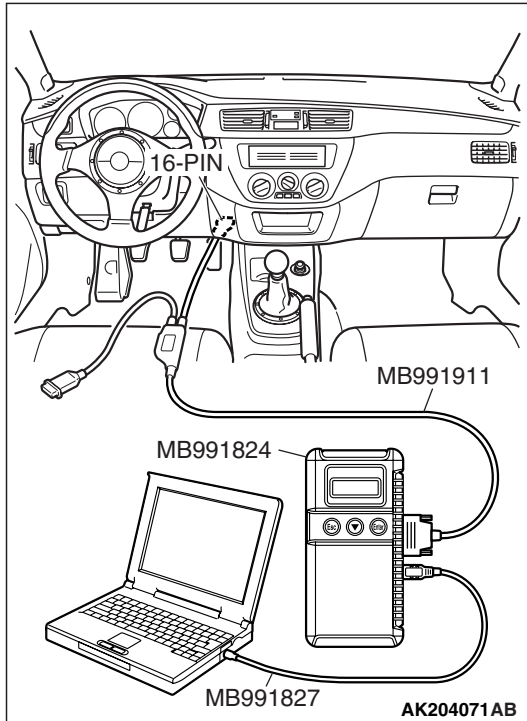

**CAUTION**

To prevent damage to scan tool MB991958, always turn the ignition switch to the "LOCK" (OFF) position before connecting or disconnecting scan tool MB991958.

1. Connect scan tool MB991958 to the data link connector.
2. Turn the ignition switch to the "ON" position.
3. Select "Check Mode" form the menu screen.
4. Select "ERASE MEMORY" form the menu screen.
5. Initialize the learning value.
6. After initialization of the learning value, learn the idling in MFI engine. (Refer to LEARNING PROCEDURE FOR IDLING IN MFI ENGINE).

## LEARNING PROCEDURE FOR IDLING IN MFI ENGINE

M1001011800373

### PURPOSE

When the ECM is replaced, or when the learning value is initialized, the idling is not stabilized because the learning value in MFI engine is not completed. In this case, carry out the learning method for the idling through the following procedures.

### LEARNING PROCEDURE

1. Start the engine and carry out the warm-up for the engine coolant temperature to reach 80° C (176° F) or more.
2. When the engine coolant temperature is 80° C (176° F) or more, the warm-up is not needed if the ignition switch is in "ON" position once.
3. Place the ignition switch in "LOCK" (OFF) position and stop the engine.
4. After 10 seconds or more, start the engine again.
5. For 10 minutes, carry out the idling under the condition shown below and then confirm the engine has the normal idling.
  - Transaxle: Neutral
  - Operation in ignition-related, fan and attachments: Not to be operated
  - Engine coolant temperature: 80° C (176° F) or more

*NOTE: When the engine stalls during the idling, check the dirtiness (on the throttle valve) of the throttle body and then perform the service from Procedure 1 again.*

## SERVICING ELECTRICAL SYSTEM

M1001011900262

**⚠ WARNING**

**Battery posts, terminals and related accessories contain lead and lead compounds. WASH HANDS AFTER HANDLING.**

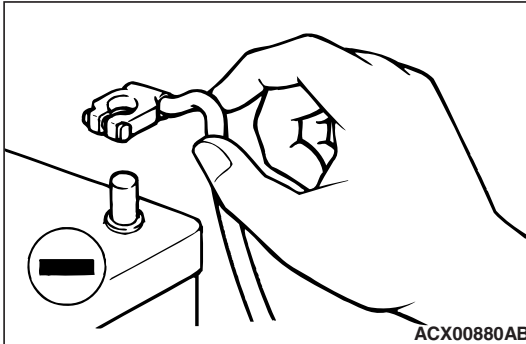

1. Note the following before proceeding with working on the electrical system.

Never perform unauthorized modifications to any electrical device or wiring. Such modifications might lead to a vehicle malfunction, over-capacity or short-circuit that could result in a fire in the vehicle.

**⚠ CAUTION**

- Before connecting or disconnecting the negative battery cable, be sure to turn the ignition switch to the "LOCK" (OFF) position and turn off the lights. (If this is not done, there is the possibility of semiconductor parts being damaged.)
  - After completion of the work (and the negative battery terminals is connected), warm up the engine and allow it to idle for approximately 10 minutes under the conditions described below in order to stabilize engine control conditions, and then check to be sure that the idle is satisfactory.
    - Engine coolant temperature: 85 – 95° C (185 – 203° F)
    - Lights and all accessories: OFF
    - Transaxle: "N" position
    - Steering wheel: straight-forward position
2. When servicing the electrical system, disconnect the negative cable terminal from the battery.

## VEHICLE WASHING

M1001012000132

If high-pressure car-washing equipment or steam car-washing equipment is used to wash the vehicle, be sure to maintain the spray nozzle at a distance of at least approximately 40cm (16 inches) from any plastic parts and all opening parts (doors, luggage compartment, etc.).

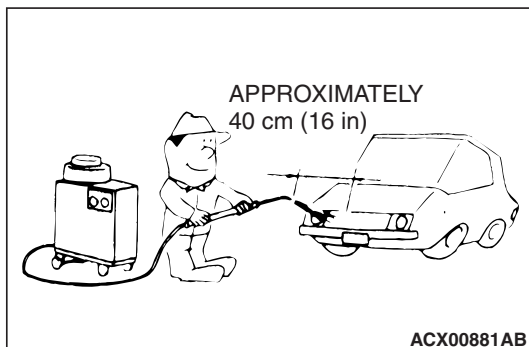
APPLICATION OF ANTI-CORROSION AGENTS  
AND UNDERCOATS

M1001011000128

Be careful not to apply oil or grease to the heated oxygen sensor. If applied, the sensor may malfunction. Protect the heated oxygen sensor with a cover before applying anti-corrosion agent, etc.



SCAN TOOL(MULTI USE TESTER { M.U.T.-III } SUB ASSEMBLY)

M1001012400044

**CAUTION**

Turn the ignition switch to the "LOCK" (OFF) position before disconnecting or connecting the scan tool.

NOTE: MB991826 M.U.T.-III Trigger Harness is not necessary when pushing V.C.I. ENTER key.

VEHICLE COMMUNICATION  
INTERFACE (V.C.I.)

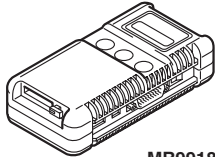

MB991824

M.U.T.-III USB CABLE

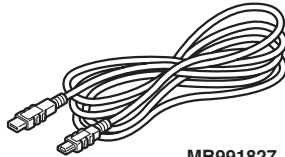

MB991827

M.U.T.-III MAIN HARNESS A

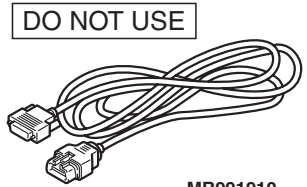

MB991910

M.U.T.-III MAIN HARNESS B

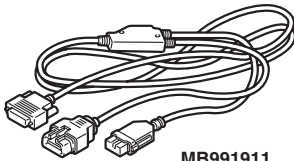

MB991911

M.U.T.-III MAIN HARNESS C

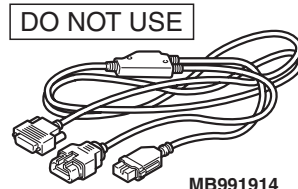

MB991914

M.U.T.-III MEASUREMENT ADAPTER

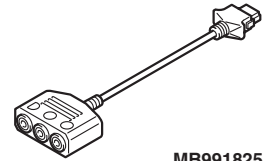

MB991825

M.U.T.-III TRIGGER HARNESS



MB991826

AC504424AB

**TOWING AND HOISTING**

M1001000800324

**WRECKER TOWING RECOMMENDATION****FRONT TOWING PICKUP****⚠ CAUTION**

- The vehicle must not be towed by placing only its front wheels on a rolling dolly, because to do so will result in deterioration of the viscous coupling and in the viscous coupling causing the vehicle to jump forward suddenly.
- If this vehicle is towed, use flat bed equipment

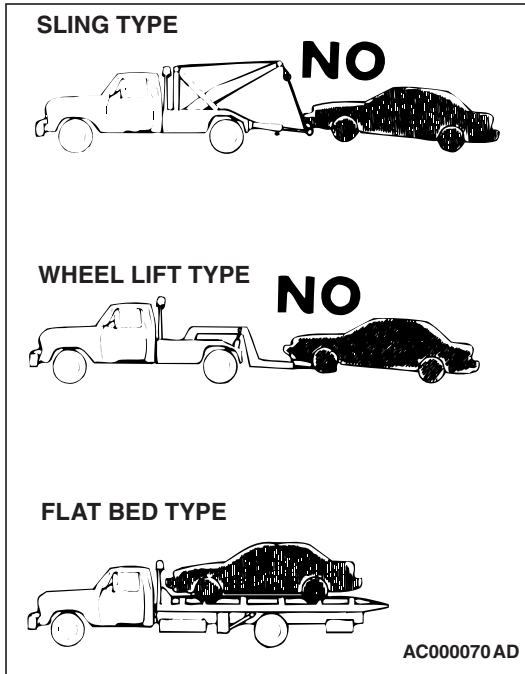
**REAR TOWING PICKUP****⚠ CAUTION**

- The vehicle must not be towed by placing only the rear wheels on a rolling dolly, because to do so will result in deterioration of the viscous coupling causing the vehicle to jump forward suddenly.
- If this vehicle is towed, use flat bed equipment.

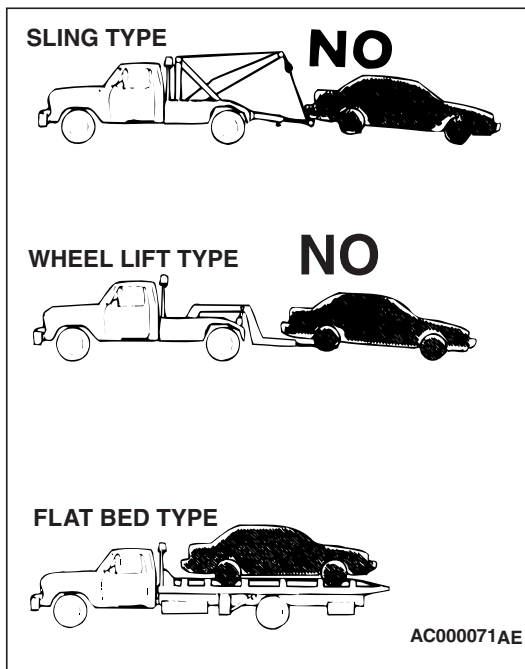
**SAFETY PRECAUTIONS**

The following precautions should be taken when towing the vehicle:

1. DO NOT LIFT OR TOW THE VEHICLE BY ATTACHING TO OR WRAPPING AROUND THE BUMPER.
2. Any loose, protruding, or damaged parts such as hoods, doors, fenders, trim, etc. should be secured or removed prior to moving the vehicle.
3. Refrain from going under a vehicle when it is lifted by the towing equipment, unless the vehicle is adequately supported by safety stands.
4. Never allow passengers to ride in a towed vehicle.
5. State and local rules and regulations must be followed when towing a vehicle.

## LIFTING, JACKING SUPPORT LOCATION

### FLOOR JACK

**⚠ CAUTION**

- Never support any point other than the specified one, or that point will be damaged.
- For lifting, put rubber or similar material between the side sill and rigid rack, or the side sill area will be damaged.

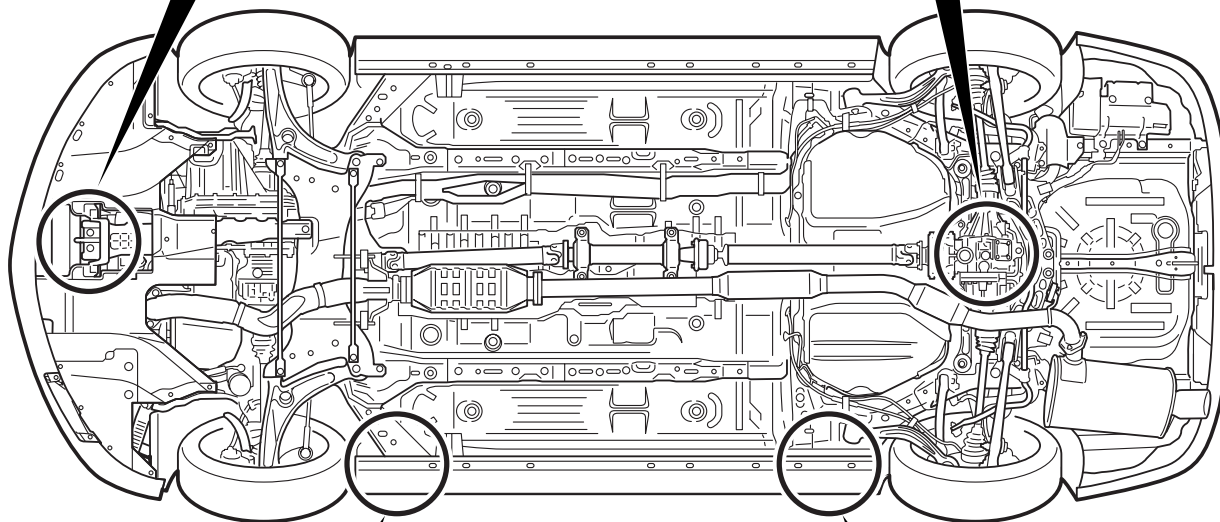
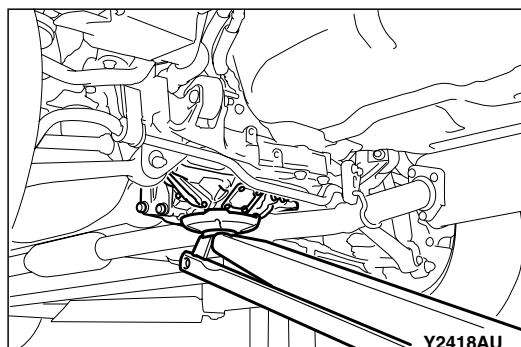
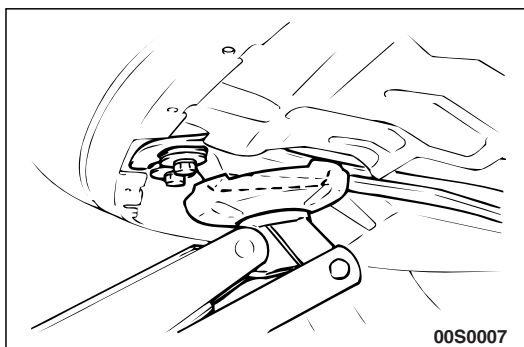

### RIGID RACK

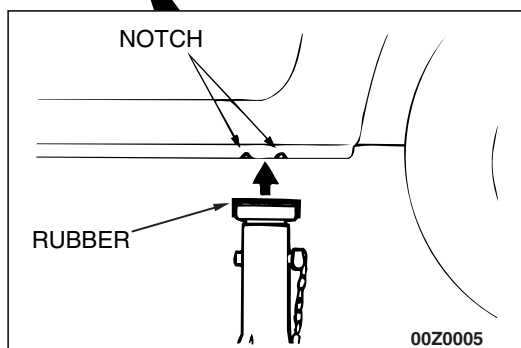
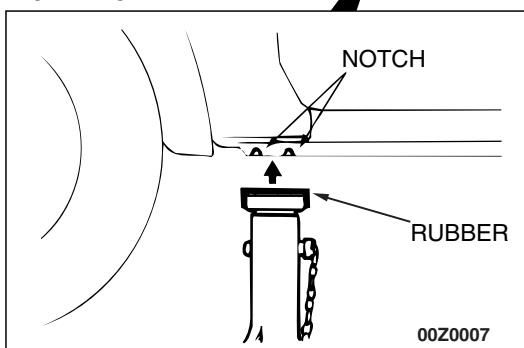

AC211777AB

**POST TYPE**

Special care should be taken when raising the vehicle on a frame contact type hoist. The hoist must be equipped with the proper adapters in order to support the vehicle at the proper locations.

**⚠ CAUTION**

When service procedures require removing rear suspension, fuel tank and spare tire, place additional weight on rear end of vehicle or anchor vehicle to hoist to prevent tipping when the location of the center of gravity changes.

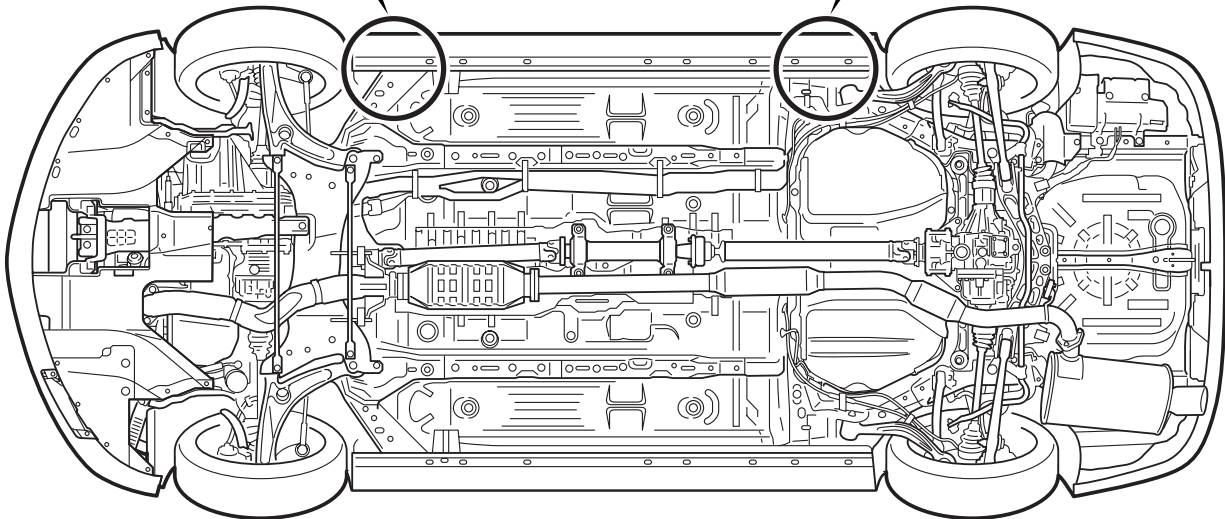
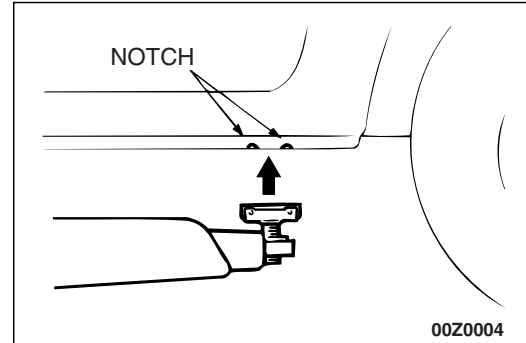
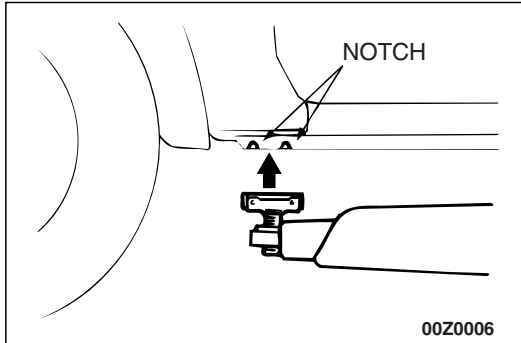
AC211557  
AC211778 AB

# GENERAL DATA AND SPECIFICATIONS

M1001000901056

## GENERAL SPECIFICATIONS

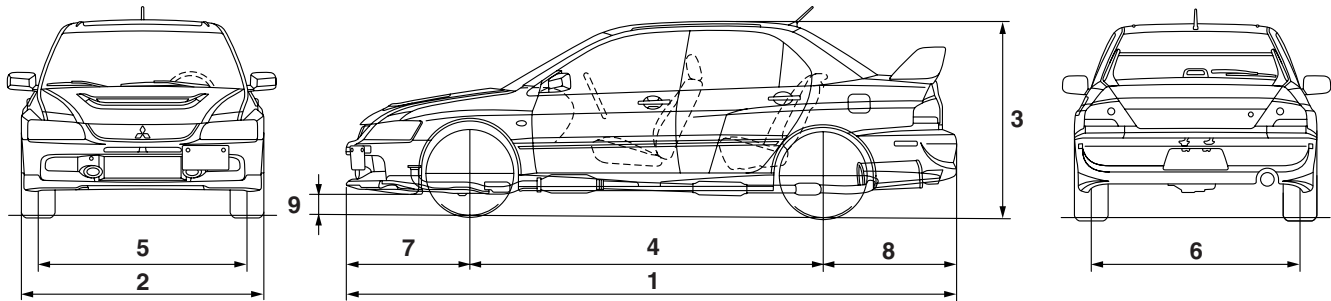

AC505134AB

ITEM		RS		GSR	
			CT9ASNDFZL2M	CT9ASNGFZL2M	CT9ASJGFZL2M
Vehicle dimension mm (in)	Overall length	1	4,535 (178.5)		
	Overall width	2	1,770 (69.7)		
	Overall height (unladen)	3	1,450 (57.1)		
	Wheelbase	4	2,625 (103.3)		
	Tread-front	5	1,515 (59.6)		
	Tread-rear	6	1,515 (59.6)		
	Front overhang	7	930 (36.6)		
	Rear overhang	8	980 (38.6)		
	Minimum running ground clearance	9	140 (5.5)		
Vehicle weight kg (lb)	Curb weight		1,440 (3,174)	1,485 (3,274)	1,490 (3,284)
	Gross vehicle weight rating		1,915 (4,222)		
	Gross axle weight rating-front		1,030 (2,270)		
	Gross axle weight rating-rear		905 (1,995)		
Seating capacity			5		
Engine	Model type		4G63-DOHC-Intercooler, Turbocharger		
	Piston displacement cm <sup>3</sup> (cu.in)		1,997 (121.9)		
	Maximum output kW/rpm (HP/r/min)		206/6,500 (276/6,500)		
	Maximum torque N· m/rpm (lbs-ft/r/min)		387/3,500 (285/3,500)		

ITEM		RS	GSR	
		CT9ASNDFZL2M	CT9ASNGFZL2M	CT9ASJGFZL2M
Transaxle	Model type	W5M51		W6MAA
	Transaxle type	5-speed forward, 1-speed reverse constant mesh		6-speed forward, 1-speed reverse constant mesh
Fuel system	Fuel supply system	Electronic controlled multiport fuel injection		

## TIGHTENING TORQUE

M1001001100771

Each torque value in the table is a standard value for tightening under the following conditions.

1. Bolts, nuts and washers are all made of steel and plated with zinc.
2. The threads and bearing surface of bolts and nuts are all in dry condition.
1. If toothed washers are inserted.
2. If plastic parts are fastened.
3. If bolts are tightened to plastic or die-cast inserted nuts.
4. If self-tapping screws or self-locking nuts are used.

The values in the table are not applicable:

### STANDARD BOLT AND NUT TIGHTENING TORQUE

THREAD SIZE		STANDARD TIGHTENING TORQUE		
NOMINAL BOLT DIAMETER (mm)	PITCH (mm)	HEAD MARK "4"	HEAD MARK "7"	HEAD MARK "8"
M5	0.8	2.5 ± 0.5 N·m (23 ± 4 in-lb)	5.0 ± 1.0 N·m (44 ± 9 in-lb)	6.0 ± 1.0 N·m (53 ± 9 in-lb)
M6	1.0	5.0 ± 1.0 N·m (44 ± 9 in-lb)	8.5 ± 1.5 N·m (76 ± 13 in-lb)	10 ± 2 N·m (89 ± 17 in-lb)
M8	1.25	11 ± 2 N·m (98 ± 17 in-lb)	20 ± 4 N·m (15 ± 3 ft-lb)	24 ± 4 N·m (18 ± 3 ft-lb)
M10	1.25	23 ± 4 N·m (17 ± 3 ft-lb)	42 ± 8 N·m (31 ± 6 ft-lb)	53 ± 7 N·m (39 ± 5 ft-lb)
M12	1.25	42 ± 8 N·m (31 ± 6 ft-lb)	80 ± 10 N·m (59 ± 7 ft-lb)	93 ± 12 N·m (68 ± 9 ft-lb)
M14	1.5	70 ± 10 N·m (52 ± 7 ft-lb)	130 ± 20 N·m (96 ± 15 ft-lb)	150 ± 20 N·m (111 ± 14 ft-lb)
M16	1.5	105 ± 15 N·m (78 ± 11 ft-lb)	195 ± 25 N·m (144 ± 18 ft-lb)	230 ± 30 N·m (170 ± 22 ft-lb)
M18	1.5	150 ± 20 N·m (111 ± 14 ft-lb)	290 ± 40 N·m (214 ± 29 ft-lb)	335 ± 45 N·m (247 ± 33 ft-lb)
M20	1.5	210 ± 30 N·m (155 ± 22 ft-lb)	400 ± 60 N·m (295 ± 44 ft-lb)	465 ± 65 N·m (343 ± 48 ft-lb)
M22	1.5	290 ± 40 N·m (214 ± 29 ft-lb)	540 ± 80 N·m (398 ± 59 ft-lb)	630 ± 90 N·m (465 ± 66 ft-lb)
M24	1.5	375 ± 55 N·m (277 ± 40 ft-lb)	705 ± 105 N·m (520 ± 77 ft-lb)	820 ± 120 N·m (605 ± 88 ft-lb)

**FLANGE BOLT AND NUT TIGHTENING TORQUE**

THREAD SIZE		STANDARD TIGHTENING TORQUE		
NOMINAL BOLT DIAMETER (mm)	PITCH (mm)	HEAD MARK "4"	HEAD MARK "7"	HEAD MARK "8"
M6	1.0	5.0 ± 1.0 N· m (44 ± 9 in-lb)	10 ± 2 N· m (89 ± 17 in-lb)	12 ± 2 N· m (107 ± 17 in-lb)
M8	1.25	13 ± 2 N· m (111 ± 22 in-lb)	24 ± 4 N· m (18 ± 3 ft-lb)	28 ± 5 N· m (20 ± 4 ft-lb)
M10	1.25	26 ± 5 N· m (19 ± 4 ft-lb)	50 ± 5 N· m (37 ± 4 ft-lb)	58 ± 7 N· m (43 ± 5 ft-lb)
M10	1.5	25 ± 4 N· m (18 ± 3 ft-lb)	46 ± 8 N· m (34 ± 6 ft-lb)	55 ± 5 N· m (41 ± 3 ft-lb)
M12	1.25	47 ± 9 N· m (35 ± 6 ft-lb)	93 ± 12 N· m (68 ± 9 ft-lb)	105 ± 15 N· m (78 ± 11 ft-lb)
M12	1.75	43 ± 8 N· m (32 ± 6 ft-lb)	83 ± 12 N· m (61 ± 9 ft-lb)	98 ± 12 N· m (72 ± 9 ft-lb)

## LUBRICATION AND MAINTENANCE

M1001001200477

Maintenance and lubrication service recommendations have been compiled to provide maximum protection for the vehicle owner's investment against all reasonable types of driving conditions. Since these conditions vary with the individual vehicle owner's driving habits, the area in which the vehicle is operated and the type of driving to which the vehicle is subjected, it is necessary to prescribe lubrication and maintenance service on a time frequency as well as mileage interval basis.

Oils, lubricants and greases are classified and graded according to standards recommended by the Society of Automotive Engineers (SAE), the American Petroleum Institute (API) and the National Lubricating Grease Institute (NLGI).

### MAINTENANCE SCHEDULES

Information for service maintenance is provided in the "SCHEDULED MAINTENANCE TABLE." Three schedules are provided; one for "Required Maintenance," one for "General Maintenance" and one for "Severe Usage Service."

The item numbers in "SCHEDULED MAINTENANCE TABLE" correspond to the section numbers in "MAINTENANCE SERVICE."

### SEVERE SERVICE

Vehicles operating under severe service conditions will require more frequent service.

Component service information is included for vehicles operating under one or more of the following conditions:

1. Trailer towing or police, taxi or commercial type operation.

### 2. Operation of Vehicle

- (1) Short-trip operation at freezing temperature (engine not thoroughly warmed up)
- (2) More than 50% operation in heavy city traffic during hot weather above 32° C (90° F)
- (3) Extensive idling
- (4) Driving in sandy areas
- (5) Driving in salty areas
- (6) Driving in dusty conditions
- (7) Driving off-road

### ENGINE OIL

**⚠ CAUTION**

**Test results submitted to EPA have shown that laboratory animals develop skin cancer after prolonged contact with used engine oil. Accordingly, the potential exists for humans to develop a number of skin disorders, including cancer, from such exposure to used engine oil. Therefore, when changing engine oil, be careful not to touch it as much as possible. Protective clothing and gloves, that cannot be penetrated by oil, should be worn. The skin should be thoroughly washed with soap and water, or use waterless hand cleaner, to remove any used engine oil. Do not use gasoline, thinners, or solvents.**

Either of the following engine oils should be used:

1. Engine oil displaying ILSAC certification symbol.
2. Engine oil conforming to the API classification SL or SL/CF. For further details, refer to "LUBRICANTS SELECTION P.00-33."

## LUBRICANTS AND GREASES

Semi-solid lubricants bear the NLGI designation and are further classified as grades 0, 1, 2, 3, etc. Whenever "Chassis Lubricant" is specified, Multipurpose Grease, NLGI grade Number 2, should be used.

## FUEL USAGE STATEMENT

### CAUTION

**Using leaded gasoline in this car will damage the catalytic converters and heated oxygen sensors, and affect the warranty coverage validity.**

This vehicle must use unleaded gasoline only.

This vehicle has a fuel filler tube which is especially designed to accept only the smaller-diameter unleaded gasoline dispensing nozzle.

The 2.0L model is designed to operate on premium grade unleaded gasoline having a minimum octane rating of 93 [(MON + RON)/2], or 98 RON.

#### NOTE:

- *MON: Motor Octane Number*
- *RON: Research Octane Number*

## GASOLINE CONTAINING ALCOHOL

Some gasoline sold at service stations contain alcohol although they may not be so identified.

Using fuels containing alcohol is not recommended unless the nature of the blend can be determined as being satisfactory.

Gasohol: A mixture of 10% ethanol (grain alcohol) and 90% unleaded gasoline may be used in your vehicle. If driveability problems are experienced as a result of using gasohol, it is recommended that the vehicle be operated on gasoline.

Methanol: **Do not use gasoline containing methanol (wood alcohol).** Using this type of alcohol can result in vehicle performance deterioration and damage critical parts in the fuel system components. Fuel system damage and performance problems resulting from the use of gasoline containing methanol may not be covered by the new vehicle warranty.

## GASOLINE CONTAINING METHYL TERTIARY BUTYL ETHER (MTBE)

Unleaded gasoline containing 15% or less MTBE may be used in your vehicle. (Fuel containing MTBE over 15% in volume may cause reduced engine performance and produce vapor lock or hard starting.)

## MATERIALS ADDED TO FUEL

Indiscriminate use of fuel system cleaning agents should be avoided. Many of these materials intended for gum and varnish removal may contain highly active solvents or similar ingredients that can be harmful to gasket and diaphragm materials used in fuel system component parts.



## RECOMMENDED LUBRICANTS AND LUBRICANT CAPACITIES TABLE

M1001001300593

### RECOMMENDED LUBRICANTS

LUBRICANT		SPECIFICATION	REMARK
Engine oil		Fully synthetic engine oils displaying ILSAC certification symbol ("Starburst" symbol) or conforming to the API classification SL, SL/CF or higher	For further details, refer to "LUBRICANTS SELECTION" section .
Engine coolant		Long Life Antifreeze Coolant or an equivalent	-
Manual transaxle oil	W5M51	DiaQueen NEW MULTI GEAR OIL API classification GL-3, SAE 75W-80 or Gear oil API classification GL-4, SAE 75W-85/75W-90	-
	W6MAA	DIA QUEEN super multi gear 75W-85W (GL-4) or exact equivalent	-
Transfer oil		MITSUBISHI limited slip differential oil (LSD) or equivalent	-
Active Center Differential (ACD) fluid		DIAMOND ATF SP III	-
Rear differential gear oil		MITSUBISHI Limited Slip Differential Oil (LSD) or equivalent	-
Power steering fluid		GENUINE MITSUBISHI POWER STEERING FLUID	-
Brake fluid		Conforming to DOT 3 or DOT 4	-
Door hinges		Engine oil	-

## LUBRICANT CAPACITY TABLE

DESCRIPTION		SPECIFICATION
Engine oil dm <sup>3</sup> (qt)	Oil pan (excluding oil filter and oil cooler)	4.5 (4.8)
	Oil filter	0.3 (0.32)
	Oil cooler	0.5 (0.52)
Fuel tank dm <sup>3</sup> (gal)		53 (14.0)
Engine coolant dm <sup>3</sup> (qt)		6.0 (6.3)
Manual transaxle oil dm <sup>3</sup> (qt)	W5M51	2.8 (3.0)
	W6MAA	2.2 (2.3)
Transfer oil dm <sup>3</sup> (qt)		0.6 (0.63)
Active Center Differential (ACD) fluid dm <sup>3</sup> (qt)		0.9 (0.95)
Power steering fluid dm <sup>3</sup> (qt)	Oil pump	1.0 (1.1)
	Gear box	As required

## LUBRICANT SELECTION

## ENGINE OIL

**⚠ CAUTION**

**Never use nondetergent or straight mineral oil.**

**Oil Identification Symbol**

Use only engine oils displaying the ILSAC certification symbol ("Starburst" symbol) on the container.

ILSAC CERTIFICATION SYMBOL  
("STARBURST" SYMBOL)



ACX00394AJ

API SERVICE SYMBOL

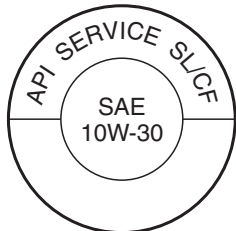

AC210927AB

If these oils are not available, an API classification SL or SL/CF or higher can be used.

### OIL VISCOSITY

The SAE grade number indicates the viscosity of the oil. A proper SAE grade number should be selected according to ambient temperature.

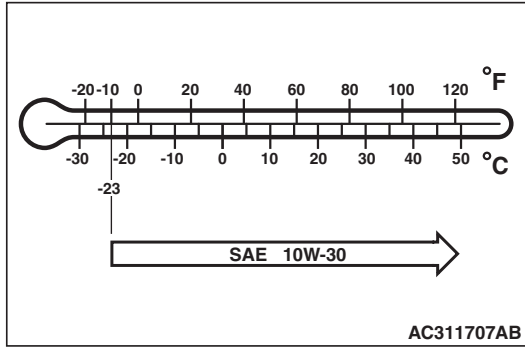

### SELECTION OF COOLANT

#### COOLANT

Relationship between Coolant Concentration and Specific Gravity

**⚠ CAUTION**

- If the concentration of the coolant is below 30%, the anti-corrosion property will be adversely affected. In addition, if the concentration is above 60%, both the anti-freeze and engine cooling properties will decrease, affecting the engine adversely. For these reasons, be sure to maintain the concentration level within the specified range.
- Do not use a mixture of different brands of anti-freeze.

ENGINE COOLANT TEMPERATURE °C (°F) AND SPECIFIC GRAVITY					FREEZING TEMPERATURE	SAFE OPERATING TEMPERATURE	COOLANT CONCENTRATION (SPECIFIC VOLUME)
10 (50)	20 (68)	30 (86)	40 (104)	50 (122)	°C (°F)	°C (°F)	%
1.054	1.050	1.046	1.042	1.036	-16 (3.2)	-11 (12.2)	30
1.063	1.058	1.054	1.049	1.044	-20 (-4)	-15 (5)	35
1.071	1.067	1.062	1.057	1.052	-25 (-13)	-20 (-4)	40
1.079	1.074	1.069	1.064	1.058	-30 (-22)	-25 (-13)	45
1.087	1.082	1.076	1.070	1.064	-36 (-32.8)	-31 (-23.8)	50
1.095	1.090	1.084	1.077	1.070	-42 (-44)	-37 (-35)	55
1.103	1.098	1.092	1.084	1.076	-50 (-58)	-45 (-49)	60

**Example**

The safe operating temperature is -15°C (5°F) when the specific gravity is 1.058 at the engine coolant temperature of 20°C (68°F)

## SCHEDULED MAINTENANCE TABLE

M1001001400664

SCHEDULED MAINTENANCE SERVICE FOR EMISSION CONTROL AND PROPER  
VEHICLE PERFORMANCE

Inspection and service should be performed any time a malfunction is observed or suspected.

NO.	EMISSION CONTROL SYSTEM MAINTENANCE	SERVICE INTERVALS	KILOMETERS IN THOUSANDS	24	48	72	96	120	144	168	192	216	240
			MILEAGE IN THOUSANDS	15	30	45	60	75	90	105	120	135	150
			MONTHS	15	30	45	60	75	90	105	120	135	150
1	Fuel system (tank, pipe line and connection, and fuel tank filler tube cap)	Check for leaks			X <sup>*3</sup>		X		X		X		X
2	Fuel hoses	Check condition			X <sup>*3</sup>		X		X		X		X
3	Air cleaner element	Replace		X <sup>*1</sup>	X	X	X	X	X	X	X	X	X
4	Evaporative emission control system (except evaporative emission canister)	Check for leaks and clogging					X				X		
5	Spark plugs	Iridium-tipped type	Replace				X				X		
6	Timing belt	Replace					X <sup>*1</sup>			X <sup>*2</sup>	X <sup>*4</sup>		
7	Drive belts (for the generator, water pump, power steering pump)	Replace			X		X		X		X		X
8	Exhaust system (connection portion of muffler, muffler pipes and converter heat shields)	Check and service			X <sup>*3</sup>		X		X		X		X

**GENERAL MAINTENANCE SERVICE FOR PROPER VEHICLE PERFORMANCE**

NO.	GENERAL MAINTENANCE	SERVICE INTERVALS	KILOMETERS IN THOUSANDS	24	48	72	96	120	144	168	192	216	240	
				MILEAGE IN THOUSANDS	15	30	45	60	75	90	105	120	135	150
				MONTHS	15	30	45	60	75	90	105	120	135	150
9	Engine oil	Turbo	Change	Every 5 months or every 8,000 km (5,000 miles)										
10	Engine oil filter	Turbo	Replace	Every 5 months or every 8,000 km (5,000 miles)										
11	Manual transaxle oil	Check oil level		X		X		X		X		X		
		Change			X		X		X		X		X	
12	Transfer oil	Check oil level		X		X		X		X		X		
		Change			X		X		X		X		X	
13	Reserve tank for ACD <sup>*6</sup>	Check fluid level		X	X	X	X	X	X	X	X	X	X	
14	Engine coolant	Change			X		X		X		X		X	
15	Coolant hoses (radiator hose, heater hose)	Inspect			X				X				X	
		Replace					X				X			
16	Disc brake pads, rotors	Inspect for wear		Every 5 months or every 8,000 km (5,000 miles)										
17	Brake hoses	Check for deterioration or leaks		X	X	X	X	X	X	X	X	X	X	
18	Ball joint and steering linkage seals	Inspect for grease leaks and damage		X	X	X	X	X	X	X	X	X	X	
19	Suspension system	Inspect for looseness and damage		Every 5 months or every 8,000 km (5,000 miles)										
20	Driveshaft boots	Inspect for grease leaks and damage		Every 5 months or every 8,000 km (5,000 miles)										
21	Rear axle oil	With LSD <sup>*5</sup>	Change		X		X		X		X		X	
22	Tires	Rotate		Every 5 months or every 8,000 km (5,000 miles)										
23	Air purifier filter	Replace		X	X	X	X	X	X	X	X	X	X	

**NOTE:**

<sup>\*1</sup>: For California, Massachusetts, Vermont and Maine, this maintenance is recommended but not required to maintain the emissions warranty.

<sup>\*2</sup>: This maintenance is not required if previously replaced.

<sup>\*3</sup>: This maintenance is recommended but is not required to maintain the emissions warranty.

<sup>\*4</sup>: In case of replaced at 96,000 km (60 miles)

<sup>\*5</sup>: LSD (Limited Slip Differential)

<sup>\*6</sup>: ACD (Active Center Differential)

**SCHEDULED MAINTENANCE UNDER SEVERE USAGE CONDITIONS**

Maintenance should be carried out according to the following table:

NO.	EMISSION CONTROL SYSTEM MAINTENANCE	SERVICE INTERVALS	KILOMETERS IN THOUSANDS	24	48	72	96	120	144	168	192	216	240
			MILEAGE IN THOUSANDS	15	30	45	60	75	90	105	120	135	150
			MONTHS	16	32	48	64	80	96	112	128	144	160
1	Fuel system (tank, pipe line and connection, and fuel tank filler tube cap)	Check for leaks			X		X		X		X		X
2	Fuel hoses	Check condition			X		X		X		X		X
3	Air cleaner element	Replace		X	X	X	X	X	X	X	X	X	X
4	Evaporative emission control system (except evaporative emission canister)	Check for leaks and clogging					X				X		
5	Spark plugs	Iridium-tipped type	Replace				X				X		
6	Timing belt	Replace					X				X		
7	Drive belts (for the generator, water pump, power steering pump)	Replace			X		X		X		X		X
8	Exhaust system (connections portion of muffler, muffler pipes and converter heat shields)	Check and service			X		X		X		X		X

**GENERAL  
SCHEDULED MAINTENANCE TABLE**

**00-39**

NO.	GENERAL MAINTENANCE	SERVICE INTERVALS	KILOMETERS IN THOUSANDS	24	48	72	96	120	144	168	192	216	240	
				MILEAGE IN THOUSANDS	15	30	45	60	75	90	105	120	135	150
				MONTHS	16	32	48	64	80	96	112	128	144	160
9	Engine oil	Turbo	Change	Every 4 months or every 6,000 km (3,750 miles)										
10	Engine oil filter	Turbo	Replace	Every 4 months or every 6,000 km (3,750 miles)										
11	Manual transaxle oil	Change		X	X	X	X	X	X	X	X	X	X	
12	Transfer oil	Change		X	X	X	X	X	X	X	X	X	X	
13	Reserve tank for ACD* <sup>6</sup>	Check fluid level		X	X	X	X	X	X	X	X	X	X	
14	Engine coolant	Change			X		X		X		X		X	
15	Coolant hoses (radiator hose, heater hose)	Inspect			X				X				X	
		Replace					X				X			
16	Disc brake pads, rotors	Inspect for wear		Every 4 months or every 6,000 km (3,750 miles)										
17	Brake hoses	Check for deterioration or leaks		X	X	X	X	X	X	X	X	X	X	
18	Ball joint and steering linkage seals	Inspect for grease leaks and damage		X	X	X	X	X	X	X	X	X	X	
19	Suspension system	Inspect for looseness and damage		Every 4 months or every 6,000 km (3,750 miles)										
20	Drive shaft boots	Inspect for grease leaks and damage		Every 4 months or every 6,000 km (3,750 miles)										
21	Rear axle oil	With LSD * <sup>5</sup>	Change		X		X		X		X		X	
22	Tires	Rotate		Every 4 months or every 6,000 km (3,750 miles)										
24	Air purifier filter	Inspect for clogging		X	X	X	X	X	X	X	X	X	X	

**NOTE:**

\*<sup>5</sup>: LSD (Limited Slip Differential)

\*<sup>6</sup>: ACD (Active Center Differential)

**Severe usage conditions:**

- Driving on dusty, rough, muddy or salt-spread roads
- Towing or police, taxi or commercial operation
- Extensive idling and/or low speed operation
- Repeated short-trip operation at freezing temperatures (engine not thoroughly warmed up)
- Extended use of brakes while driving
- Driving in sandy areas
- More than 50% operation in heavy city traffic during hot weather above 32° C (90° F)

**MAINTENANCE SERVICE****1. FUEL SYSTEM (TANK, PIPE LINE AND CONNECTION, AND FUEL TANK FILLER TUBE CAP) (CHECK FOR LEAKS)**

M1001001600293

Check for damage or leakage in the fuel lines and connections.

**2. FUEL HOSES (CHECK CONDITION)**

M1001001700289

1. Inspect the surface of fuel hoses for heat and mechanical damage. Hard and brittle rubber, cracking, tears, cuts, abrasions and excessive swelling indicate deterioration of the rubber.
2. If the fabric casing of the rubber hose is exposed by cracks and abrasions in the fuel system, the hoses should be replaced.

**3. AIR CLEANER ELEMENT (REPLACE)**

M1001001800305

The air cleaner element will become dirty during use, reducing its effectiveness. Replace it with a new one.

**REPLACEMENT OF AIR CLEANER ELEMENT**

1. Unclamp the air cleaner cover.
2. Remove the air cleaner element and install a new one.
3. When clamping the air cleaner cover in place, be sure that the cover is completely closed.

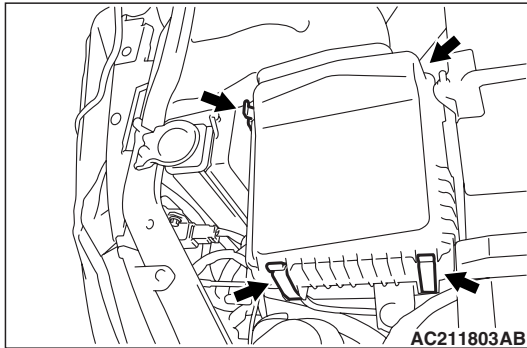
**4. EVAPORATIVE EMISSION CONTROL SYSTEM (EXCEPT EVAPORATIVE EMISSION CANISTER) (CHECK FOR CLOGGING)**

M1001001900294

If the fuel-vapor vent line is clogged or damaged, fuel vapor will escape into the atmosphere causing excessive emissions. Disconnect the line at both ends, and blow it clean with compressed air. Remove the fuel tank filler tube cap from the filler tube and check to see if there is evidence that the seal makes improper contact to the filler tube.



## 5. SPARK PLUGS (REPLACE)

M1001002000432

### ⚠ CAUTION

Iridium plugs are used. Use care not to damage the iridium and platinum tips of the plugs. Do not adjust the spark plug gap.

1. Spark plugs must spark properly to assure proper engine performance and reduce exhaust emission level. Therefore, they should be replaced periodically with new ones.

Spark plug type

MAKER	IDENTIFICATION NO.
NGK	ILFR7H

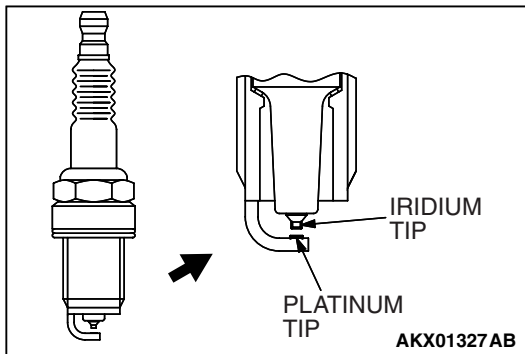

2. The new plugs should be checked for the proper gap.

**Spark plug gap: 0.5 –0.6 mm (0.020 –0.024 inch)**

3. Install the spark plugs and tighten to 25±5 N· m (18±4 ft-lb).

## 6. TIMING BELT (REPLACE)

M1001002300433

Replace the belt with a new one according to the maintenance schedule on (P.00-36) to assure proper engine performance.

For removal and installation procedures, refer to GROUP 11A, Engine Mechanical –Timing Belt –Removal and Installation P.11A-48.

## 7. DRIVE BELT (FOR GENERATOR, WATER PUMP AND POWER STEERING OIL PUMP) (CHECK CONDITION)

M1001002500545

### Drive Belt Tension Check

<When using scan tool MB991958>

#### Required Special Tools:

- MB991668: Belt Tension Meter Set
- MB991958: Scan Tool (M.U.T.-III Sub Assembly)
  - MB991824: V.C.I.
  - MB991911: Main Harness B

1. Check the drive belt tension. (Refer to P.11A-8.)
2. Measure the drive belt tension vibration frequency by the following procedures:

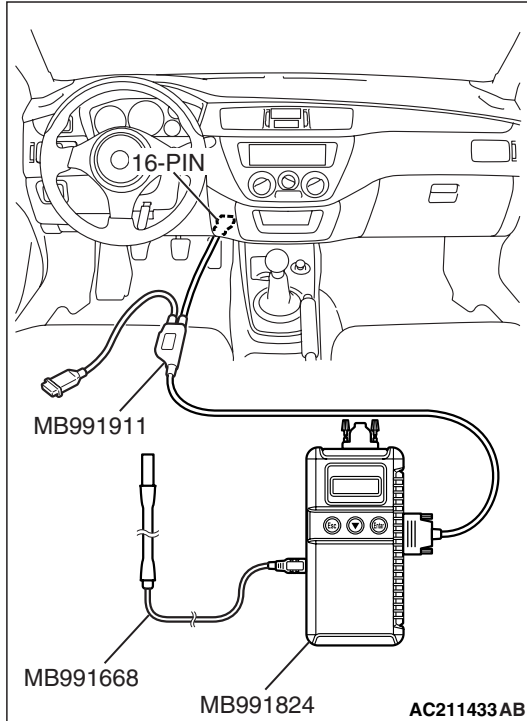
**⚠ CAUTION**

To prevent damage to scan tool MB991824, always turn the ignition switch to the "LOCK" (OFF) position before connecting or disconnecting scan tool MB991824.

- (1) Connect special tool MB991668 to scan tool MB991824.
- (2) Connect scan tool MB991911 to scan tool MB991824.
- (3) Connect scan tool MB991911 to the data link connector.
- (4) Turn the ignition switch to the "ON" position and select "Belt Tension Measurement" from the menu scan tool MB991824 screen.

**⚠ CAUTION**

- The temperature of the surface of the belt should be as close to normal temperature as possible.
  - Do not allow any contaminants such as water or oil to get onto the microphone.
  - If strong gusts of wind blow against the microphone or if there are any loud sources of noise nearby, the values measured by the microphone may not correspond to actual values.
  - If the microphone is touching the belt while the measurement is being made, the values measured by the microphone may not correspond to actual values.
  - Do not take the measurement while the vehicle's engine is running.
- (5) Hold special tool MB991668 to the middle of the drive belt between the pulleys (at the place indicated by arrow), approximately 10 –20 mm (0.40 –0.78 inch) away from the rear surface of the belt so that it is perpendicular to the belt (within an angle of  $\pm 15$  degree).
  - (6) Gently tap the middle of the belt between the pulleys (the place indicated by the arrow) with your finger as shown in the illustration, and measure that the vibration frequency of the belt is within the standard value.

**Standard value: 110 –144 Hz**

3. If not within the standard value, replace the auto-tensioner. (Refer to [P.11A-48.](#))

**<When using a tension gauge>**

1. Check the drive belt tension. (Refer to [P.11A-8.](#))
2. Use a belt tension gauge in the middle of the belt between the pulleys (at the place indicated by the arrow) to measure that the belt tension is within the standard value.

**Standard value: 245 –412 N**

3. If not within the standard value, replace the auto-tensioner. (Refer to [P.11A-48.](#))

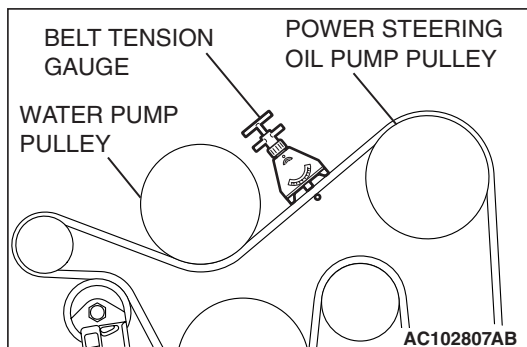
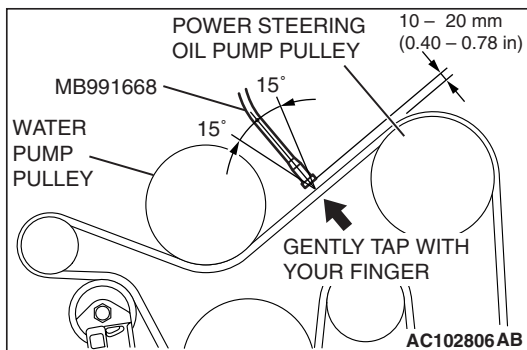

## 8. EXHAUST SYSTEM (CONNECTION PORTION OF MUFFLER, MUFFLER PIPES AND CONVERTER HEAT SHIELDS) (CHECK AND SERVICE)

M1001005800404

1. Check for holes and exhaust gas leaks due to damage, corrosion, etc.
2. Check the joints and connections for looseness and exhaust gas leaks.
3. Check the rubber hangers and brackets for damage.

## 9. ENGINE OIL (CHANGE)

M1001002600586

1. Start the engine and allow it to warm up until the temperature of the coolant reaches 80°C (176°F) to 90°C (194°F).

### **⚠ WARNING**

*Use care as oil could be hot.*

2. Remove the engine oil filler cap.
3. Remove the drain plug to drain oil.
4. Install a new drain plug gasket so that it faces in the direction shown in the illustration, and then tighten the drain plug to the specified torque.

**Tightening torque: 39 ± 5 N·m (29 ± 3 ft-lb)**

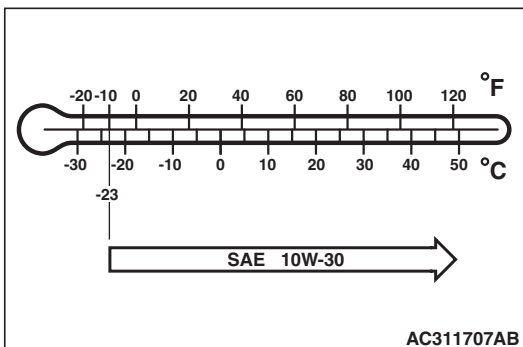
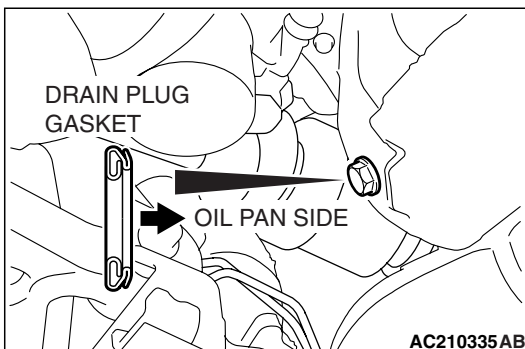

### **⚠ CAUTION**

- Do not use conventional petroleum based motor oil. Using conventional motor oil may cause engine or turbocharger damage.
  - Do not use "blends" of conventional oil and synthetic oil.
5. Refill the specified quantity of oil.
    - Specified Engine Oil: Fully synthetic engine oils displaying ILSAC certification symbol ("Starburst" symbol) or conforming to the API classification SL or SL/CF or higher
    - Total quantity (Includes volume inside oil filter and oil cooler): 5.1 dm<sup>3</sup> (5.4 quarts)
- NOTE: SAE 5W-30 fully synthetic engine oil can be used to improve engine startability in very cold weather areas where the lowest atmospheric temperature is below -18°C (0°F).*
6. Install the engine oil filler cap.
  7. Start the engine and run it at idle for a few minutes.

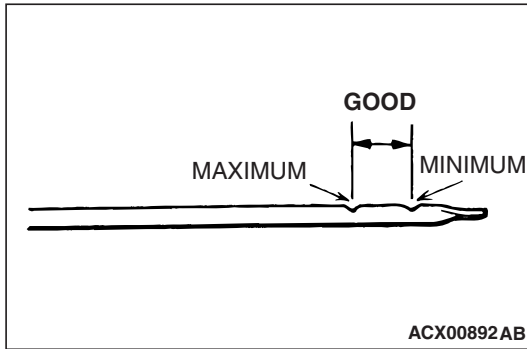

8. Stop the engine and check to ensure that the engine oil level is within the level range indicated on the dip stick.

## 10. ENGINE OIL FILTER (REPLACE)

M1001002700453

The quality of replacement filters varies considerably. Only high quality filters should be used to assure most efficient service. Genuine oil filters require that the filter is capable of withstanding a pressure of 1,800 kPa (261 psi) are high quality filters and are recommended as follows:

**Mitsubishi Oil Filter Part Number: MD356000 or equivalent**

### Engine Oil Filter Selection

The same type of filter is recommended as a replacement filter for this vehicle. It is possible, particularly in cold weather, that this vehicle may develop high oil pressure for a short duration. Make sure that any replacement filter used on this vehicle is a high-quality filter. The filter must withstand a pressure of 1,800 kPa (261 psi) [manufacturer's specifications] to avoid filter and ultimately engine damage. The following is a high-quality filter and is strongly recommended for use on this vehicle: Mitsubishi Engine Oil Filter Part number MD356000. Any replacement oil filter should be installed in accordance with the oil filter manufacturer's installation instructions.

### Oil Filter Replacement

1. Start the engine and allow it to warm up until the temperature of the coolant reaches 80° C (176° F) to 90° C (194° F).

#### **⚠ WARNING**

***Use care as oil could be hot.***

2. Remove the engine oil filler cap.
3. Remove the drain plug to drain oil.
4. Remove the side cover.

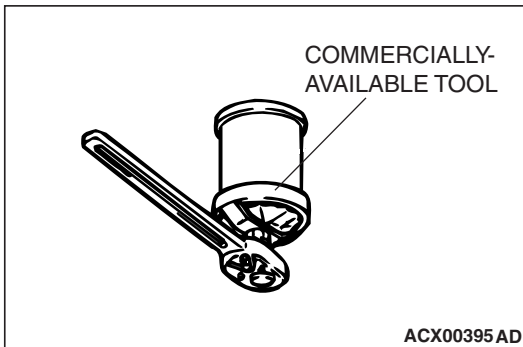

5. Use the commercially-available tool to remove the engine oil filter.
6. Clean the filter bracket side mounting surface and ensure the old O-ring has been removed.

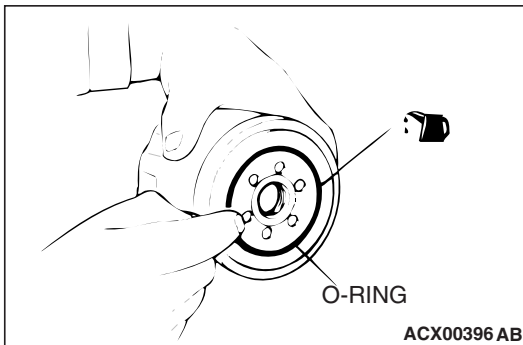

7. Apply a small amount of engine oil to the O-ring of the new oil filter.
8. Where the oil filter O-ring touches the oil pan flange, tighten the oil filter to the specified torque using the commercially-available tool.

**Tightening torque: Approximately 3/4 turn [14 ± 2 N· m (124 ± 18 in-lb)]**

9. Install the side cover.
10. Install the drain plug and refill engine oil. (Refer to Engine Oil Replacement P.12-3.)
11. Rev the engine a few times, and check to be sure that no engine oil leaks from the installation section of the oil filter.

## 11. MANUAL TRANSAXLE OIL

M1001002800290

### CHECK OIL LEVEL

Inspect each component for evidence of leakage. Check the oil level by removing the filler plug.

1. Remove the filler plug.
2. Check that the oil level is up to the lower edge of the filler plug hole.
3. Check that the oil is not noticeably dirty.
4. Tighten the filler plug to the specified torque.

**Tightening torque: 32 ± 2 N· m (23 ± 2 ft-lb)**

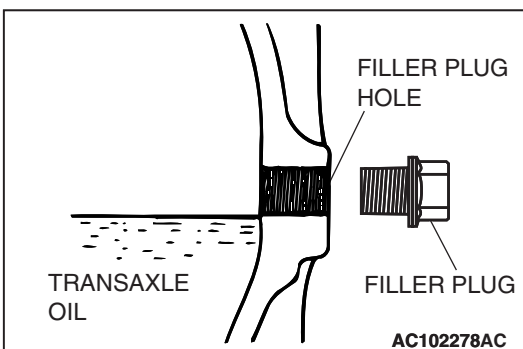

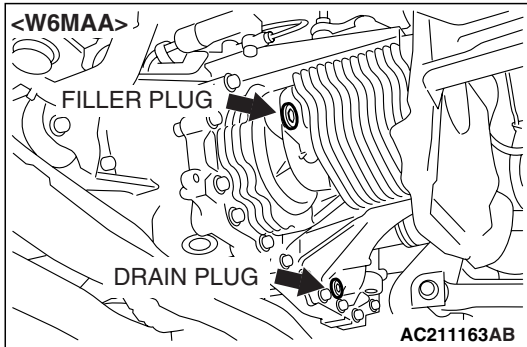
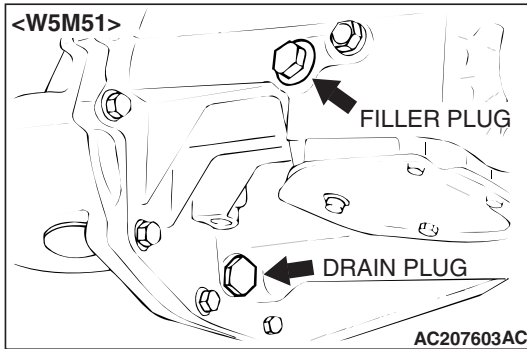
**CHANGE OIL**

1. Remove the filler plug.
2. Remove the drain plug and drain the oil.
3. Tighten the oil drain plug to the specified torque.

**Tightening torque <W5M51>:  $32 \pm 2$  N·m (23 ± 2 ft-lb)**

**Tightening torque <W6MAA>:  $35 \pm 4$  N·m (26 ± 3 ft-lb)**

4. Fill with specified oil till the level comes to the lower portion of oil filler plug hole.

**Specified transmission oil <W5M51>: Gear oil API classification GL-4 SAE 75W-85W or 75W-90**

**Specified transmission oil <W6MAA>: DIA QUEEN SUPER MULTI GEAR SAE 75W-85 (GL-4) or exact equivalent**

**Quantity <W5M51>: 2.8 dm<sup>3</sup> (2.9 quart)**

**Quantity <W6MAA>: 2.2 dm<sup>3</sup> (2.3 quart)**

5. Tighten the oil filler plug to the specified torque.

**Tightening torque <W5M51>:  $32 \pm 2$  N·m (23 ± 2 ft-lb)**

**Tightening torque <W6MAA>:  $35 \pm 4$  N·m (26 ± 3 ft-lb)**

**12. TRANSFER OIL**

M1001003000189

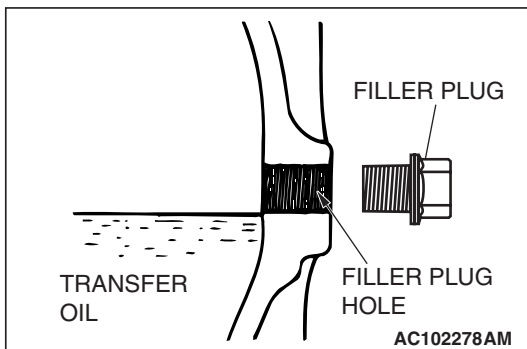
**TRANSFER OIL LEVEL CHECK**

1. Remove the filler plug.
2. Check that the oil level is up to the lower edge of the filler plug hole.
3. Check that the oil is not noticeably dirty.
4. Tighten the filler plug to the specified torque.

**Tightening torque:  $32 \pm 2$  N·m (23 ± 2 ft-lb)**

**TRANSFER OIL CHANGE**

1. Remove the filler plug.
2. Remove the drain plug and drain the oil.
3. Tighten the drain plug to the specified torque.

**Tightening torque:  $32 \pm 2$  N·m (23 ± 2 ft-lb)**

**⚠ CAUTION**

**Cover the heat protector of the front exhaust pipe with cardboard or something similar when refilling transfer oil so that transfer oil does not enter the area between the front exhaust pipe and heat protector.**

4. Fill with hypoid gear oil API classification GL-5 SAE90 until the level comes to the lower portion of filler plug hole.

**Quantity: 0.6 dm<sup>3</sup> (0.63 quart)**

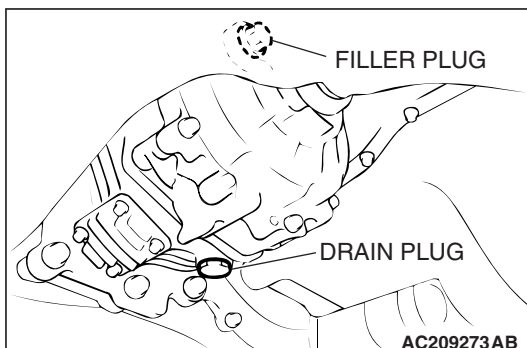

5. Tighten the filler plug to the specified torque.

**Tightening torque:  $32 \pm 2$  N·m ( $23 \pm 2$  ft·lb)**

### 13. RESERVE TANK FOR ACD (CHECK FLUID LEVEL)

M1001014700018

1. <Not using scan tool MB991958>

- If the vehicle has been run, leave it for 90 min. or more in an ordinary temperature [ $10^{\circ}\text{C} - 30^{\circ}\text{C}$  ( $50^{\circ}\text{F} - 86^{\circ}\text{F}$ )] to allow the accumulator internal pressure to drop.

*NOTE: If the ambient temperature is  $10^{\circ}\text{C}$  ( $50^{\circ}\text{F}$ ) or less, allow more time to leave the vehicle to stand idle.*

2. <Using scan tool MB991958>

#### **⚠ CAUTION**

**To prevent damage to scan tool MB991958, always turn the ignition switch to the "LOCK" (OFF) position before connecting or disconnecting scan tool MB991958.**

- Connect scan tool MB991958 to the data link connector.
- Turn "ON" the ignition switch, perform scan tool MB991958 actuator test (Item No.03), forcibly drive the hydraulic unit and remove the pressure in the accumulator.

#### **NOTE:**

- *In the actuator test (Item No.03: Oil Level Check Mode), the proportioning valve of the hydraulic unit is moved to the left and right for 20 times, and then the differential is cleared automatically. Drive can also be cleared forcibly using the clear key of the scan tool MB991958.*
- *If the function has been stopped by fail-safe, the hydraulic unit cannot be cleared forcibly.*

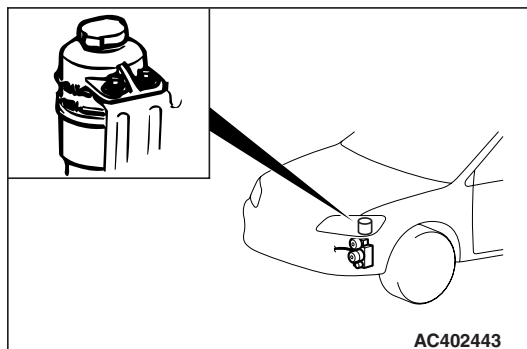
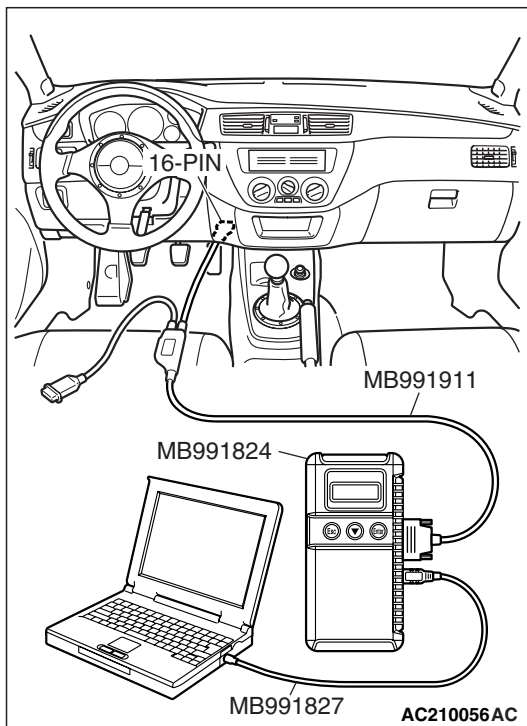

3. Check that the fluid level in the oil reservoir is in the range between MAX and MIN.

4. If the fluid level is lower than MIN, add the specified fluid.

**Specified fluid: DIAMOND ATF SP III**

5. Reinstall the maintenance lid.

**14. ENGINE COOLANT (CHANGE)**

M1001003100506

Check the cooling system parts such as the radiator, heater and oil cooler hoses, thermostat and their connections for leakage and damage.

**CHANGING COOLANT****Required Special Tool:**

- MB991871: LLC Changer

1. Remove the under cover (Refer to GROUP 51, Front Bumper P.51-2).

**⚠ WARNING**

***When removing the radiator cap, use care to avoid contact with hot coolant or steam. Place a shop towel over the cap and turn the cap counterclockwise a little to let the pressure escape through the vinyl tube. After relieving the steam pressure, remove the cap by slowly turning it counterclockwise.***

2. Drain the water from the radiator, heater core and engine after unplugging the radiator drain plug and removing the radiator cap.
3. Drain the water in the water jacket by unplugging the drain plug of the cylinder block.
4. Remove the reserve tank and drain the coolant.
5. Drain the cooling water then clean the path of the cooling water by injecting water into the radiator from the radiator cap area.
6. Apply the designated sealant to the screw area of the cylinder block drain plug, and then tighten to the standard torque.

**Specified sealant: 3M™ AAD Part No. 8731 or equivalent**

**Tightening torque:  $44 \pm 5$  N·m ( $33 \pm 3$  ft-lb)**

7. Securely tighten the drain plug of the radiator.
8. Assemble the reserve tank.

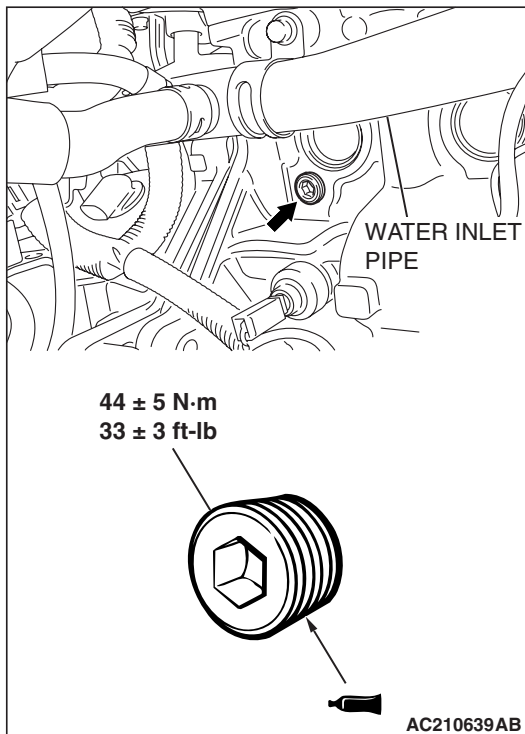



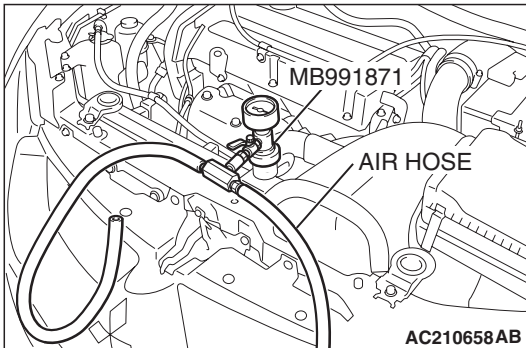

**⚠ CAUTION**

Do not use alcohol or methanol anti-freeze or any engine coolants mixed with alcohol or methanol anti-freeze. The use of an improper anti-freeze can cause corrosion of the aluminum components.

9. By referring to the section on coolant, select an appropriate concentration for safe operating temperature within the range of 30 to 60%. Use special tool MB991871 to refill the coolant. A convenient mixture is a 50% water and 50% antifreeze solution [freezing point:  $-31^{\circ}\text{C}$  ( $-23.8^{\circ}\text{F}$ )].

**Recommended antifreeze: Long Life Antifreeze Coolant or an equivalent**

**Quantity: 6.0 dm<sup>3</sup> (6.3 quarts)**

*NOTE: For how to use special tool MB991871, refer to its manufacturer's instructions.*

10. Reinstall the radiator cap.
11. Start the engine and let it warm up until the thermostat opens.
12. After repeatedly revving the engine up to 3,000 r/min several times, then stop the engine.
13. Remove the radiator cap after the engine has become cold, and pour in coolant up to the brim. Reinstall the cap.

**⚠ CAUTION**

Do not overfill the reserve tank.

14. Add coolant to the reserve tank between the "FULL" and "LOW" mark if necessary.
15. Install the under cover (Refer to GROUP 51, Front Bumper [P.51-2](#)).

**15. COOLANT HOSES (RADIATOR HOSE, HEATER HOSE) (INSPECT)**

M1001009700012

Inspect the surface of radiator hoses and heater hoses for heat and mechanical damage. Hard and brittle rubber, cracking, tears, cuts, abrasions and excessive swelling indicate deterioration of the rubber.

**16. DISC BRAKE PADS, ROTORS (INSPECT FOR WEAR)**

M1001003200268

**Disc Brake Pads Check**

Check for fluid contamination and wear. Replace the complete set of pads if any one pad is defective.

**Thickness of lining**

**Minimum limit: 2.0 mm (0.08 inch)**

**⚠ CAUTION**

The pads for the right and left wheels should be replaced at the same time. Never split or intermix brake pad sets. All four pads must be replaced as a complete set.

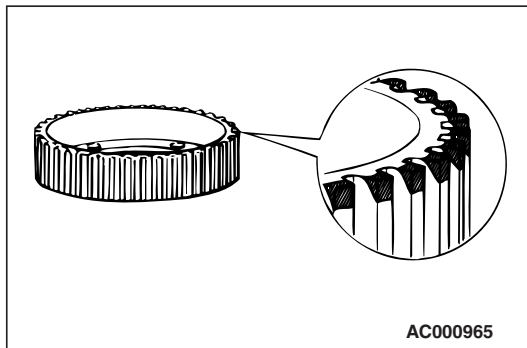
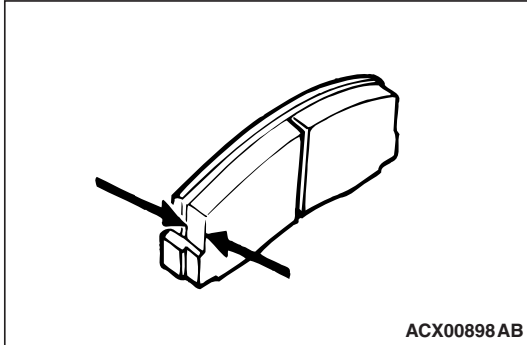
**Rotors Check**

Check whether the ABS rotor teeth are broken or deformed. Replace the Eight Ball Fixed Joint (EBJ) assembly of the drive-shaft, respectively, if the teeth are damaged or deformed.

**17. BRAKE HOSES (CHECK FOR DETERIORATION OR LEAKS)**

M1001003400295

Inspection of brake hoses should be included in all brake service operations.

The hoses should be checked for:

1. Incorrect length, severe surface cracking, pulling, scuffing or worn spots. (If the fabric casing of the hoses is exposed by cracks or abrasion in the rubber hose cover, the hoses should be replaced. Eventual deterioration of the hose and possible bursting failure may occur.)
2. Incorrect installation, twisting or interference with wheel, tire or chassis.

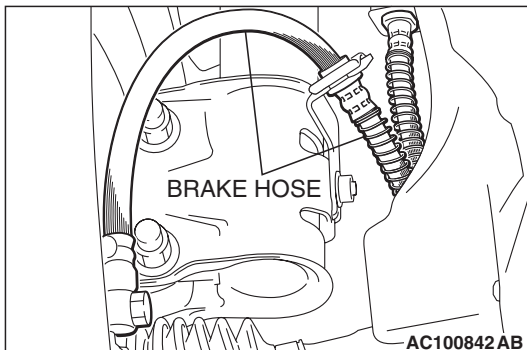

## 18. BALL JOINT AND STEERING LINKAGE SEALS (INSPECT FOR GREASE LEAKS AND DAMAGE)

M1001003500300

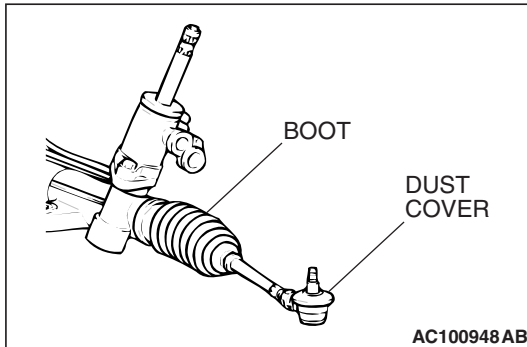

1. These components, which are permanently lubricated at the factory, do not require periodic lubrication. Damaged seals and boots should be replaced to prevent leakage or grease contamination.
2. Inspect the dust cover and boots for proper sealing, leakage and damage. Replace them if defective.

## 19. SUSPENSION SYSTEM (INSPECT FOR LOOSENESS AND DAMAGE)

M1001009600026

Visually inspect the front/rear suspension components for deterioration and damage. Re-tighten the front/rear suspension components retaining bolts to specified torque.

## 20. DRIVESHAFT BOOTS (INSPECT FOR GREASE LEAKS AND DAMAGE)

M1001003600459

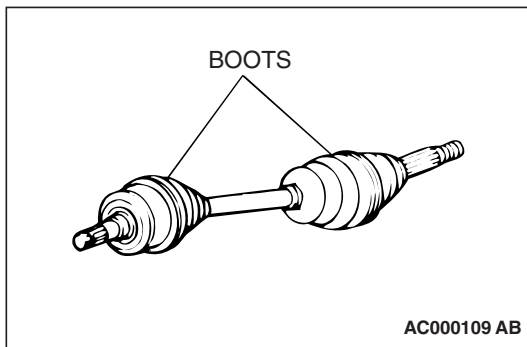

1. These components, which are permanently lubricated at the factory, do not require periodic lubrication. Damaged seals and boots should be replaced to prevent leakage or grease contamination.
2. Inspect the dust cover and boots for proper sealing, leakage and damage. Replace them if defective.

## 21. REAR AXLE OIL (CHANGE)

M1001007500120

Before the changing the rear axle oil, check that there is no oil leakage from the rear axle housing.

1. Remove the filler plug.
2. Remove the drain plug and drain out the oil.
3. Replace the packing for drain plug and tighten the drain plug to the specified torque.

**Tightening torque: 64 ± 4 N·m (47 ± 3 ft-lb)**

4. Refill engine oil via the filler hole.
  - **Specified gear oil: Hypoid gear oil MITSUBISHI Genuine Gear Oil Part No. 8149630 EX or equivalent**
  - **Quantity: 0.55 dm<sup>3</sup> (0.58 quart)**

- Replace the gasket for drain plug and tighten the drain plug to the specified torque.

**Tightening torque:  $49 \pm 9$  N·m ( $37 \pm 6$  ft-lb)**

## 22. TIRES (ROTATE)

M1001008900455

Rotate tires regularly to equalize tire wear and help extend tire life. Recommended tire rotation is every 5 months or 8,000 km (5,000 miles) under normal driving conditions and every 4 months or 6,000 km (3,750 miles) in severe driving conditions. Timing for the rotation may vary according to vehicle condition, road surface conditions, and individual driver's habits.

When rotating tires, check for uneven wear, damage, and wheel alignment. Abnormal wear is usually caused by incorrect tire pressure, improper wheel alignment, out-of-balance wheels, or severe braking.

The first rotation is the most important, to achieve more uniform wear for all tires on the vehicle.

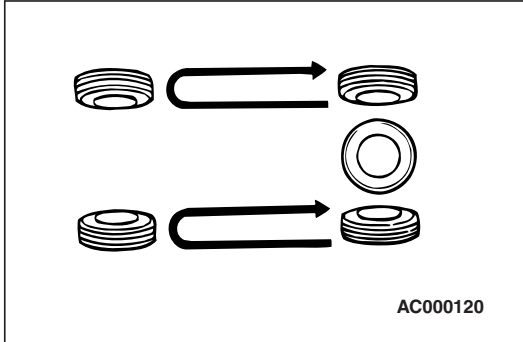

## 23. AIR FILTER (REPLACE)

M1001009000091

- Remove the glove box (Refer to group 52A, instrument panel [P.52A-3](#).)
- Remove the two screws as shown, and replace the clean air filter.
- Remove the clean air filter.
- Install the glove box.

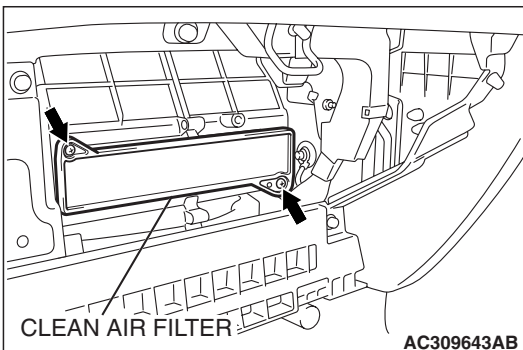

## MAIN SEALANT AND ADHESIVE TABLE

M1001003800464

APPLICATION		3M™ NO.	LOCTITE®/PERMATEX® NO.
ENGINE AND DRIVETRAIN	Between rocker cover and camshaft bearing cap. Between rocker cover, semicircular packing and cylinder head. Between oil pressure switch and engine.	3M™ AAD Part No. 8672 Ultrapro High Temp. Silicone Gasket or 3M™ AAD Part No. 8679 Black/8678 Black Press-In-Place Silicone gasket strips	Permatex® Ultra Black 598, No.82180
	Between engine coolant temperature switch, engine coolant temperature sensor, thermo valve, thermo switch, joint, engine coolant temperature gauge unit (large-size) and engine	3M™ AAD Part No. 8731 Medium Strength Blue Threadlocker	Loctite®242 Blue Service Tool Removable 24200
	Between oil pan and engine block	3M™ AAD Part No. 8672, 3M™ AAD Part No. 8704 or 3M™ AAD Part No. 8679/ 3M™ AAD Part No. 8678	Permatex® Ultra Gray 599, No.82194
WEATHER-STRIPPING FOR GLASS	Between tempered glass, body flanges, and weatherstrip	3M™ AAD Part No. 8509 Auto Bedding and Glazing Compound or 3M™ AAD Part No. 8633 Windo-weld Resealant	—
WEATHER-STRIPPING FOR GLASS	Between laminated glass and weatherstrip	3M™ AAD Part No. 8633	—
INTERIORS	Adhesive of vinyl chloride cloth	3M™ AAD Part No. 8088 General Trim Adhesive or 3M™ AAD Part No. 8064 Vinyl Trim Adhesive	Permatex® Vinyl Repair Kit No.81786
	Adhesion of door weatherstrip	3M™ AAD Part No. 8001 (yellow) or 3M™ AAD Part No. 8008 (black) Super Weatherstrip Adhesive or 3M™ AAD Part No. 8011 Black Weatherstrip Adhesive	Permatex® Super Black Weatherstrip Adhesive No.82, 81850
	Sealing of various grommets and packing	3M™ AAD Part No. 8509 or 3M™ AAD Part No. 8678	—
	Adhesion of headliners and various interior decorative materials	3M™ AAD Part No. 8088 General Trim Adhesive or 3M™ AAD Part No. 8090 Super Trim Adhesive	Permatex® Spray Adhesive No.82019

**GENERAL  
MAIN SEALANT AND ADHESIVE TABLE**

APPLICATION		3M™ NO.	LOCTITE®/PERMATEX® NO.
BODY SEALANTS	Sealing of sheet metal joints, drip rail, floor, side panels, trunk, front panel, tail gate hinge	3M™ AAD Part No. 8531 Heavy Drip-Check Sealer (gray) or 3M™ AAD Part No. 8302 Ultrapro Autobody Sealant (clear) or 3M™ AAD Part No. 8361 Urethane A/B Sealant (gray or white)	–
	Miscellaneous body sealants (originally mounted w/adhesive tape) <ul style="list-style-type: none"> <li>• Waterproof door film</li> <li>• Fender panel</li> <li>• Splash shield</li> <li>• Mud guard</li> <li>• Rear combination lamp</li> </ul>	3M™ AAD Part No. 8633 Windo-weld Resealant	–
	Fuel Tank and Pad	3M™ AAD Part No. 8088 General Trim Adhesive or 3M™ AAD Part No. 8090 Super Trim Adhesive	Permatex® Spray Adhesive No.82019
CHASSIS SEALANT	Sealing of various flange faces and threaded parts. Packing of fuel level sensor	3M™ AAD Part No. 8730 High Strength Red Thread lock or 3M™ AAD Part No. 8731 Medium Strength Blue Threadlocker	Loctite®272 High Strength and High Temperature 27200
	Sealing of various threaded parts, dust covers. Differential carrier packing, dust covers and ball joint and linkage. Packing and shims of steering box, sealing of rack support cover and top cover of steering box housing, seal of junction face of knuckle arm flange	3M™ AAD Part No. 8672 Ultrapro High Temp. Silicone Gasket or 3M™ AAD Part No. 8679 (black) or 3M™ AAD Part No. 8678 (black) Press-In-Place Silicone gasket strips 3M™ AAD Part No. 8661 or 3M™ AAD Part No. 8663 Super Silicone sealant	Permatex® The Right Stuff No.25223
	Seal of brake shoe hold-down pin and wheel cylinder of drum brakes	3M™ AAD Part No. 8633 Windo-weld Resealant	–

**GENERAL  
MAIN SEALANT AND ADHESIVE TABLE**

**00-55**

<b>APPLICATION</b>		<b>3M™ NO.</b>	<b>LOCTITE®/PERMATEX® NO.</b>
QUICK FIX ADHESIVE	–	3M™ AAD Part No. 8155 Quick Fix Adhesive	Loctite® Quicktite Super Glue 21309
ANAEROBIC STRONG SEALING AGENT	Fixing of various threads, bolts, screws. Fixing of differential drive gear bolt, Connecting of tilt steering bolt. Fan, pulley, gear sealing of small gaps and flange faces	3M™ AAD Part No. 8730 High Strength Threadlocker or 3M™ AAD Part No. 8731 Medium Strength Threadlocker	Loctite® 271, High-Strength Threadlocker 27100 or 27200
UNDERCOATING AGENT	–	3M™ AAD Part No. 8883 Rubberized Undercoating Aerosol or 3M™ AAD Part No. 8864 Body Schutz Undercoating (qt)	Permatex® Heavy-Duty Undercoating 81833

---

## NOTES