



502-MSB2-6-003-00

SERVICE MANUAL

FOR

MSB2, MSB4 & MSB6

“Quick Mount”

MagnaShear™

FULLY ELECTRIC

OIL SHEAR MOTOR BRAKE

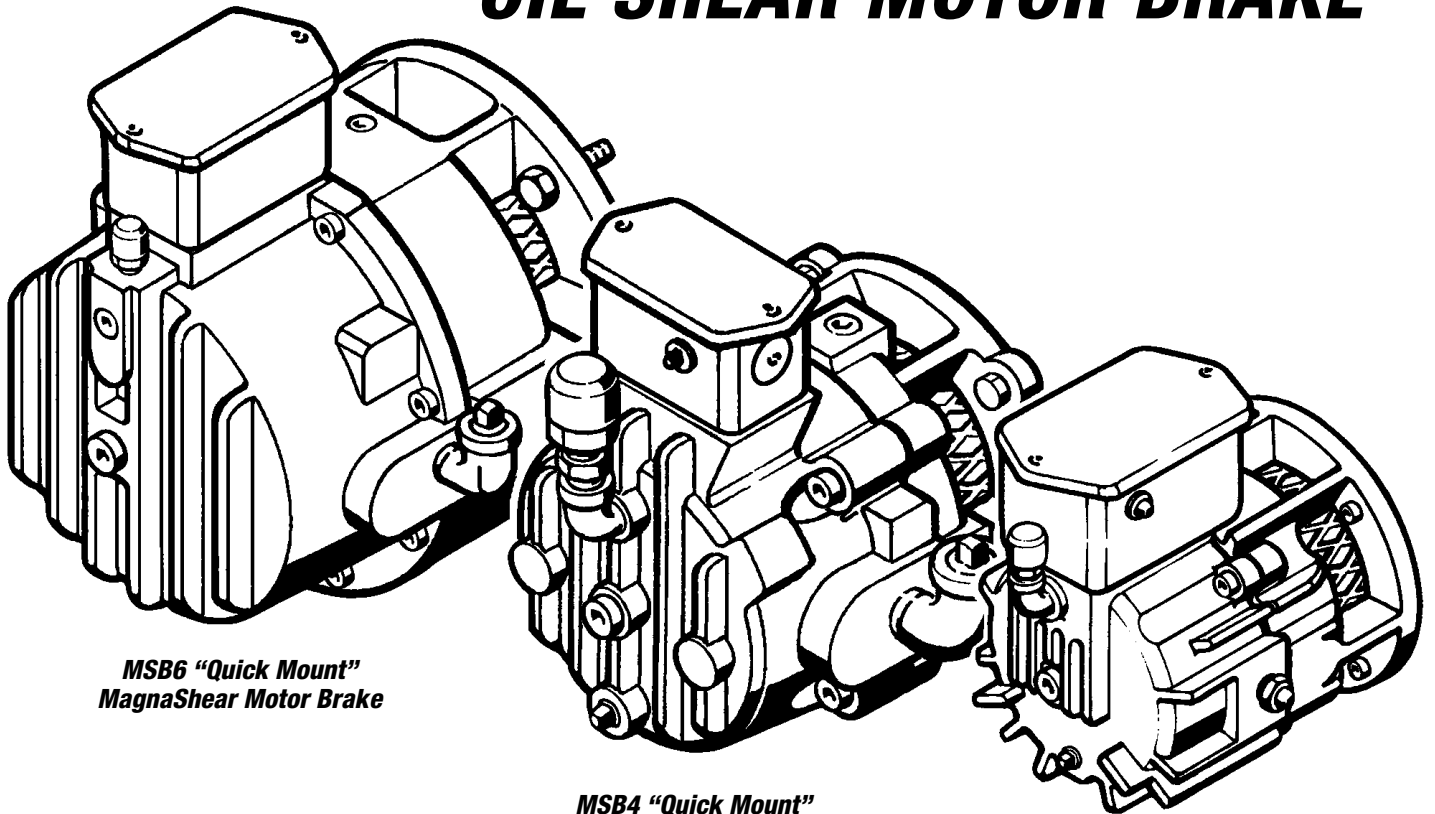

*MSB6 “Quick Mount”
MagnaShear Motor Brake*

*MSB4 “Quick Mount”
MagnaShear Motor Brake*

*MSB2 “Quick Mount”
MagnaShear Motor Brake*

WARNING - Read this manual before any installation, maintenance or operation.



FORCE CONTROL INDUSTRIES, INC.

MANUFACTURERS OF MECHANICAL AND ELECTRICAL POWER TRANSMISSION EQUIPMENT



DIST. AUTORIZADO

MEX (55) 53 63 23 31
QRO (442) 1 95 72 60

MTY (81) 83 54 10 18
ventas@industrialmagza.com

Limited Warranty

Upon written approval of the application by Force Control Industries, Inc. the standard warranty period will be extended to 24 months from date of shipment.

Force Control Industries, Inc. ("Force Control") warrants its products to be free from defects in material and workmanship under normal and proper use for a period of one year from the date of shipment. Any products purchased from Force Control that upon inspection at Force Control's factory prove to be defective as a result of normal use during the one year period will be repaired or replaced (at Force Controls' option) without any charge for parts or labor. This limited warranty shall be void in regard to (1) any product or part thereof which has been altered or repaired by a buyer without Force Control's previous written consent or (2) any product or part thereof that has been subjected to unusual electrical, physical or mechanical stress, or upon which the original identification marks have been removed or altered. Transportation charges for shipping any product or part thereof that the buyer claims is covered by this limited warranty shall be paid by the buyer. If Force Control determines that any product or part thereof should be repaired or replaced under the terms of this limited warranty it will pay for shipping the repaired or replaced product or part thereof back to the buyer. EXCEPT FOR THE EXPRESS WARRANTY SET OUT ABOVE, FORCE CONTROL DOES NOT GRANT ANY WARRANTIES EITHER EXPRESSED OR IMPLIED, INCLUDING IMPLIED WARRANTIES OF MERCHANTABILITY OR FITNESS FOR USE. The warranty obligation set forth above is in lieu of all obligations or liabilities of Force Control for any damages. Force Control specifically shall not be liable for any costs incurred by the buyer in disconnecting or re-installing any product or part thereof repaired or replace under the limited warranty set out above. FORCE CONTROL EXPRESSLY EXCLUDES ALL LIABILITY FOR ANY INDIRECT OR CONSEQUENTIAL DAMAGES THE BUYER MAY SUSTAIN IN CONNECTION WITH THE DELIVERY, USE, OR PERFORMANCE OF FORCE CONTROL PRODUCTS. Under no circumstances shall any liability for which Force Control is held responsible exceed the selling price to the buyer of the Force Control products that are proven to be defective. This limited warranty may be modified only in writing signed by a duly authorized officer of the company. This limited warranty applies exclusively to Force Control products; warranties for motors and gear reducers and other component parts may be provided by their respective manufactures. Any legal action for breach of any Force Control warranty must be commenced within one year of the date on which the breach is or should have been discovered.

A Return Goods Authorization (RGA) number must be obtained from the factory and clearly marked on the outside of the package before any equipment will be accepted for warranty work. Force Control will pay the shipping costs of returning the owner parts that are covered by warranty.

Force Control believes that the information in this document is accurate. The document has been carefully reviewed for technical accuracy. In the event that technical or typographical errors exist, Force Control reserves the right to make changes to subsequent editions of this document without prior notice to holders of this edition. The reader should consult Force Control if errors are suspected. In no event shall Force Control be liable for any damages arising out of or related to this document or the information contained in it.



FORCE CONTROL INDUSTRIES, INC.
MEX (55) 53 63 23 31 MTY (81) 83 54 10 18
QRO (442) 1 95 72 60 ventas@industrialmagza.com



TABLE OF CONTENTS

Section 1 - DESCRIPTION and OPERATION

1-1 UNIT DESCRIPTION	1
1-2 THE OIL SHEAR PRINCIPLE	1
1-3 OPERATION.....	2

Section 2 - SPECIFICATIONS

2-1 OPERATING SPECIFICATIONS.....	2
2-2 THERMAL HORSEPOWER RATINGS	3
2-3 MSB2 DIMENSIONS.....	3
2-4 MSB4 & MSB6 DIMENSIONS	4

Section 3 - INSTALLATION and START-UP

IMPORTANT SAFETY PRECAUTIONS	5
3-1 RECEIVING THE <i>MagnaShear</i> MOTOR BRAKE.....	5
A. Assembled Electric Brake Motor (EBM)	5
B. <i>MagnaShear</i> Motor Brake.....	5
3-2 VERIFYING MOTOR SPECIFICATIONS	5
3-3 INSTALLING THE <i>MagnaShear</i> BRAKE.....	6
A. MSB2 <i>MagnaShear</i>	6
B. MSB4 & MSB6 <i>MagnaShear</i>	6
3-4 VERTICAL MOUNTING	7
3-5 WIRING SPECIFICATIONS.....	7
3-6 START-UP	7

Section 4 - LUBRICATION

4-1 CHECKING THE OIL LEVEL	8
4-2 OPERATING TEMPERATURES	8
A. Ambient Temperatures	8
B. Oil Sump Temperature	8
4-3 CHANGING THE OIL.....	8
4-4 TYPE OF OIL	8

Section 5 - OPERATIONAL CHECKS

5-1 CHECKING THE BRAKE OPERATION	10
5-2 CHECKING THE BRAKE COIL OPERATION.....	10

Section 6 - TROUBLE SHOOTING

6-1 TROUBLE SHOOTING CHART.....	11
6-2 TROUBLE SHOOTING COILS.....	12
A. Coil Resistance Test.....	12
B. Coil Current Leakage Test.....	12

Section 7 - REPAIR and REPLACEMENT

7-1 GENERAL INFORMATION	13
7-2 CLEANING AND INSPECTION	13
7-3 REPAIR OR REPLACEMENT.....	13
7-4 MEASURING STACK HEIGHT	13
A. MSB2 <i>MagnaShear</i>	13
B. MSB4 & MSB6 <i>MagnaShear</i>	13

7-5 REPLACING MSB2 BRAKE STACK	14
A. Disassembly	14
B. Reassembly	14
7-6 REPLACING MSB4 & MSB6 BRAKE STACK	15
7-7 REPLACING CIRCUIT BOARD	16
7-8 REPLACING HOLDING COIL FOR MSB2	16
A. Disassembly	16
B. Reassembly	17
7-9 REPLACING HOLDING COIL FOR MSB4 & MSB6.....	17
A. Disassembly	17
B. Reassembly	17
7-10 REPLACING OIL SEAL & BEARING FOR MSB2	18
A. Disassembly	18
B. Reassembly	19
7-11 REPLACING OIL SEAL & BEARING FOR MSB4 & MSB6 .	20
A. Disassembly	20
B. Reassembly	20
7-12 FINAL REASSEMBLY PROCEDURE	21

Section 8 - ILLUSTRATED PARTS LIST

8-1 GENERAL INFORMATION	22
8-2 DRIVE MOTORS	22
8-3 FACTORY REBUILD SERVICE.....	22
8-4 ORDERING REPLACEMENT PARTS.....	22
8-5 NAME PLATE AND MODEL NUMBER.....	23
A. MSB2 <i>MagnaShear</i>	23
B. MSB4 & MSB6 <i>MagnaShear</i>	24

REPAIR PARTS LISTS

Parts List - Figure 8.1	25
Figure 8.1 - Electric Box and Circuit Board	25
Parts List - Figure 8.2	26
Figure 8.2 - MSB2 <i>MagnaShear</i> Motor Brake.....	27
Parts List - Figure 8.3	28
Figure 8.3 - MSB4 <i>MagnaShear</i> Motor Brake.....	29
Parts List - Figure 8.4	30
Figure 8.4 - MSB4 <i>MagnaShear</i> Motor Brake.....	31
Parts List - Figure 8.5	32
Figure 8.5 - MSB2 Vertical Installation	32
Parts List - Figure 8.6	33
Figure 8.6 - MSB4 Vertical Installation	33
Parts List - Figure 8.7	34
Figure 8.5 - MSB6 Vertical Installation	34
MANUAL REVISION HISTORY	35

FORCE CONTROL INDUSTRIES, INC.



MEX (55) 53 63 23 31 MTY (81) 83 54 10 18
QRO (442) 1 95 72 60 ventas@industrialmagza.com

Section 1

DESCRIPTION and OPERATION

1-1 UNIT DESCRIPTION

The **MSB2, MSB4 & MSB6 "Quick Mount" MagnaShear Fully Electric Motor Brake** with Oil Shear dependability mounts to the following NEMA standard motor frame sizes: From 56 to 254T and 284U with 5.875" or 7.250" Dia. Bolt Circle). This "Quick Mount" design means just that, quick and easy mounting to your drive motor. It comes ready to install. It does not require any disassembly of the brake for installation. IEC Frames can be available. Contact Force Control for IEC mounting configurations. Spring set torque ratings range from **6 Lb. Ft. to 86 Lb. Ft.**

A spring set brake stack is released when 115 VAC or 230 VAC (depending on model) power is supplied to the MagnaShear Brake. Control logic is made simple by use of the motor starter auxiliary contactors. Back EMF effect from the motor windings is eliminated.

The units are ideal for a wide variety of applications including indexing tables, lifts, transfer conveyors, tap heads and other start/stop devices.

1-2 THE OIL SHEAR PRINCIPLE

Conventional clutches and brakes depend on the friction between solid surfaces operating in air to transmit torque. Friction does the job but produces a great amount of heat and wear. The **MSB2, MSB4 & MSB6 MagnaShear Motor Brake** is an *Oil Shear Brake*, with the friction surfaces operating in a constantly replenished film of oil. The oil molecules tend to cling to each other and to the friction surfaces. As moving and stationary elements are brought together, a thin but positive film of oil is maintained between them which is controlled by the clamping pressure and carefully designed grooves in the friction discs. Torque is transmitted from one element to the other through the viscous shear of the oil film. As long as there is relative motion between the elements, they are protected by the oil, thus greatly reducing wear. The replenished oil film also effectively transmits heat away from the friction elements.

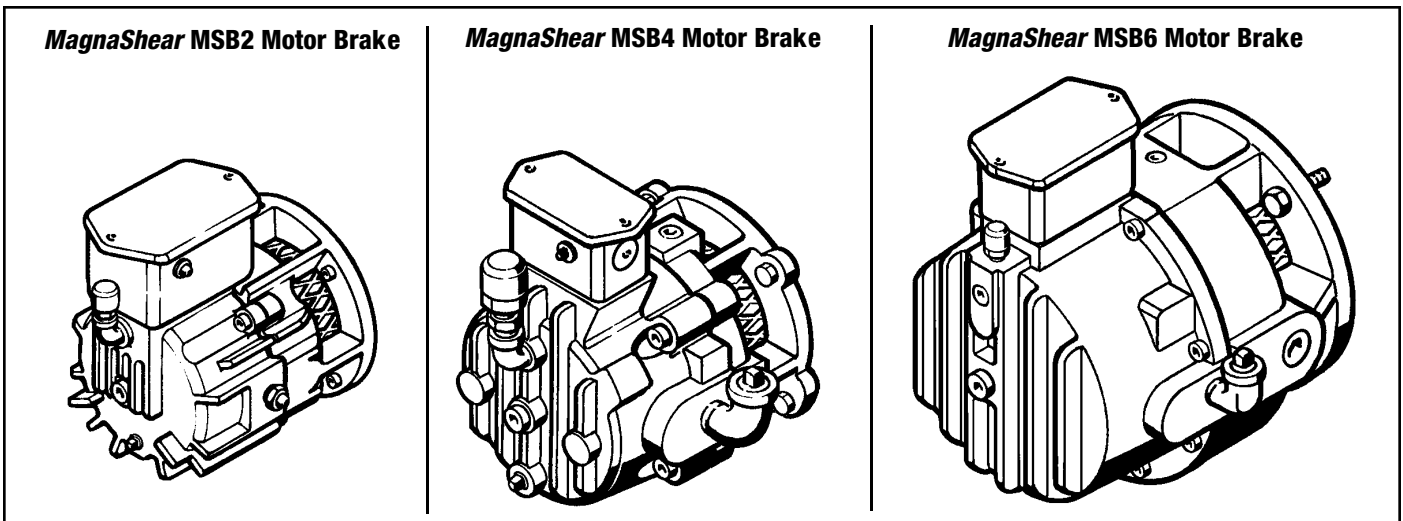
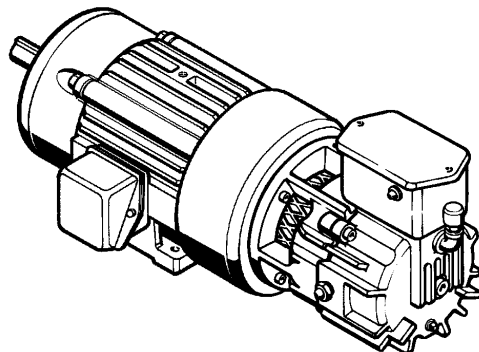

Figure 1.1 - MagnaShear "Quick Mount" Motor Brakes



MagnaShear "Quick Mount" Motor Brake furnished as an Assembled Brake Motor

FORCE CONTROL INDUSTRIES, INC.



MEX (55) 53 63 23 31 MTY (81) 83 54 10 18
 QRO (442) 1 95 72 60 ventas@industrialmagza.com

1-3 OPERATION

The cross section in *Figure 1.2* shows the **MagnaShear Motor Brake** in the Stopped position with the brake stack engaged. The **MagnaShear Motor Brake** will default to this position when all power is lost.

To run the Drive Motor the Brake Coil is energized, pulling the Armature Plate Assembly away from the Brake Stack which allows the splined hub and drive motor to rotate independently from the motor brake.

To stop the Drive Motor the Brake Coil is de-energized. This allows the brake springs to push the Armature Plate Assembly against the Brake Stack, clamping it and stopping the splined hub and drive motor.

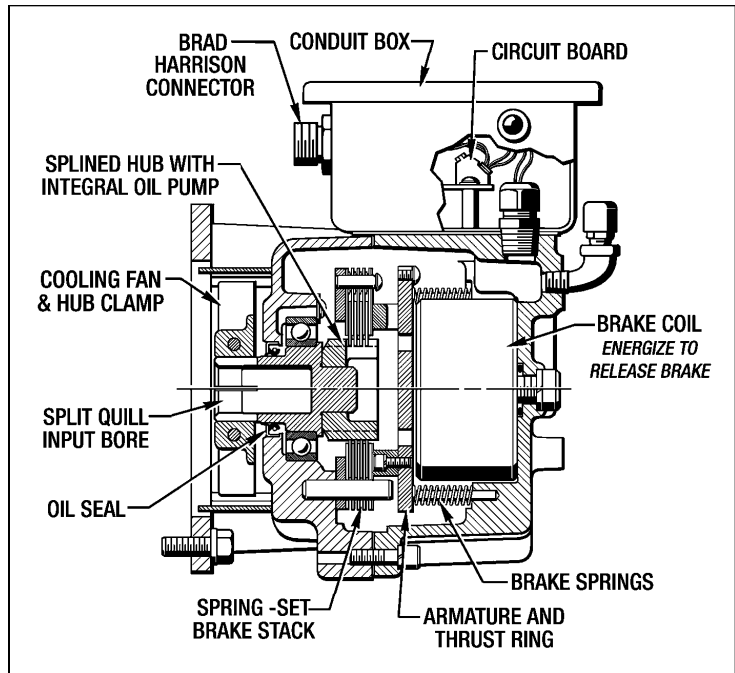

Figure 1.2 - MagnaShear "Quick Mount" Motor Brake Cross Section

Section 2 SPECIFICATIONS

2-1 MagnaShear "Quick Mount" MOTOR BRAKE OPERATING SPECIFICATIONS

BRAKE SIZE	AVAILABLE		QTY. OF SPRINGS	STATIC TORQUE (Lb. Ft.)	DYNAMIC TORQUE (Lb. Ft.)	MAX. KE per ENGMT. (Ft. Lbs.)	INERTIA (Lb. Ft. ²)	OIL CAP. (Fl. Oz.)	INPUT* VOLTAGE (VAC)	INRUSH CURRENT .4 Sec. (Amps)	HOLDING CURRENT (Amps)	MAX. DUTY CYCLE	COIL RESISTANCE @ 20° C. (Ohms)
	MNTG. BC (Inches)	COLLET BORE (Inches)											
MSB2	5.875	.625	3	6	5	7,975	0.011	28	115 230	2.5 1.3	.8 .4	100%	47 188
		.875	4	8	7								
			6	12	10								
MSB4	5.875 7.250	.875	3	14	12	22,000	0.024	40	115 230	5.5 2.2	1.7 .4	75%	47 188
		1.125	4	21	18								
			6	33	28								
MSB6	7.250	.875	4	38	32	26,500	0.058	50	115 230	6 3	1.8 .9	75%	23 92
		1.125	6	62	53								
		1.375	8	86	73								

NOTES: Above ratings are based on 96° C maximum oil temperature and 1800 RPM motor.
% - Duty is percentage of time brake is released. (Coil is Energized.)

* The MagnaShear Brake is either 115 VAC or 230 VAC (Depending on the Model Number.)

2-2 THERMAL HORSEPOWER RATING

Size MSB2

% DUTY	CYCLE RATE (cpm)	AMBIENT TEMP.	
		25° C	40° C
25%	2	.45	.17
	5	.45	.17
	10	.44	.16
50%	2	.37	.16
	5	.36	.15
	10	.35	.14
75%	2	.28	.13
	5	.27	.13
	10	.26	.12

Size MSB4

% DUTY	CYCLE RATE (cpm)	AMBIENT TEMPERATURE			
		TEFC Motor		TENV Motor	
		25° C	40° C	25° C	40° C
25%	2	0.26	0.19	0.20	0.14
	5	0.25	0.18	0.19	0.14
	10	0.24	0.17	0.18	0.13
50%	2	0.24	0.16	0.13	0.07
	5	0.24	0.15	0.12	0.06
	10	0.23	0.14	0.11	0.05
75%	2	0.23	0.13	0.05	NR
	5	0.22	0.13	NR	NR
	10	0.21	0.12	NR	NR

Size MSB6

% DUTY	CYCLE RATE (cpm)	AMBIENT TEMPERATURE			
		TEFC Motor		TENV Motor	
		25° C	40° C	25° C	40° C
25%	2	0.18	0.12	0.14	0.09
	5	0.16	0.11	0.13	0.08
	10	0.14	0.08	0.11	0.06
50%	2	0.12	0.06	0.05	NR
	5	0.11	0.12	0.14	0.09
	10	0.09	NR	NR	NR
75%	2	0.07	NR	NR	NR
	5	0.06	NR	NR	NR
	10	NR	NR	NR	NR

2-3 MSB2 MagnaShear DIMENSIONS

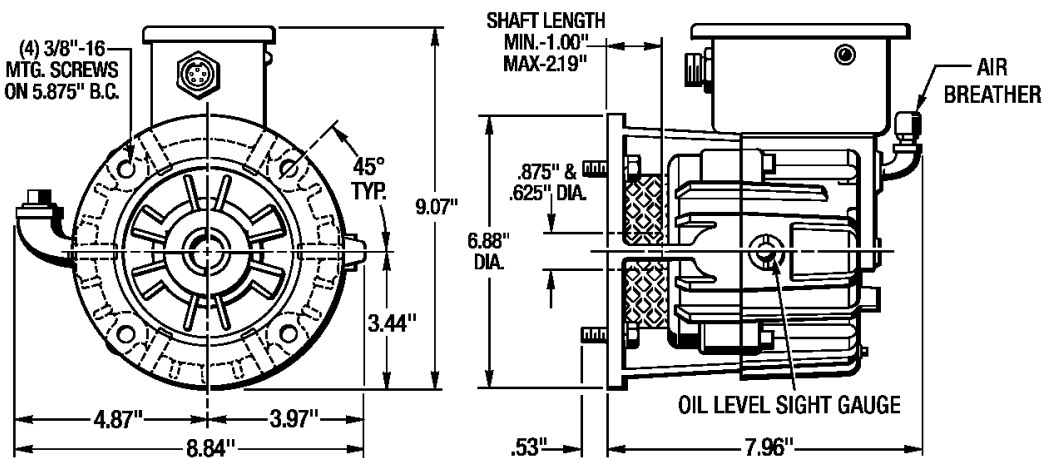
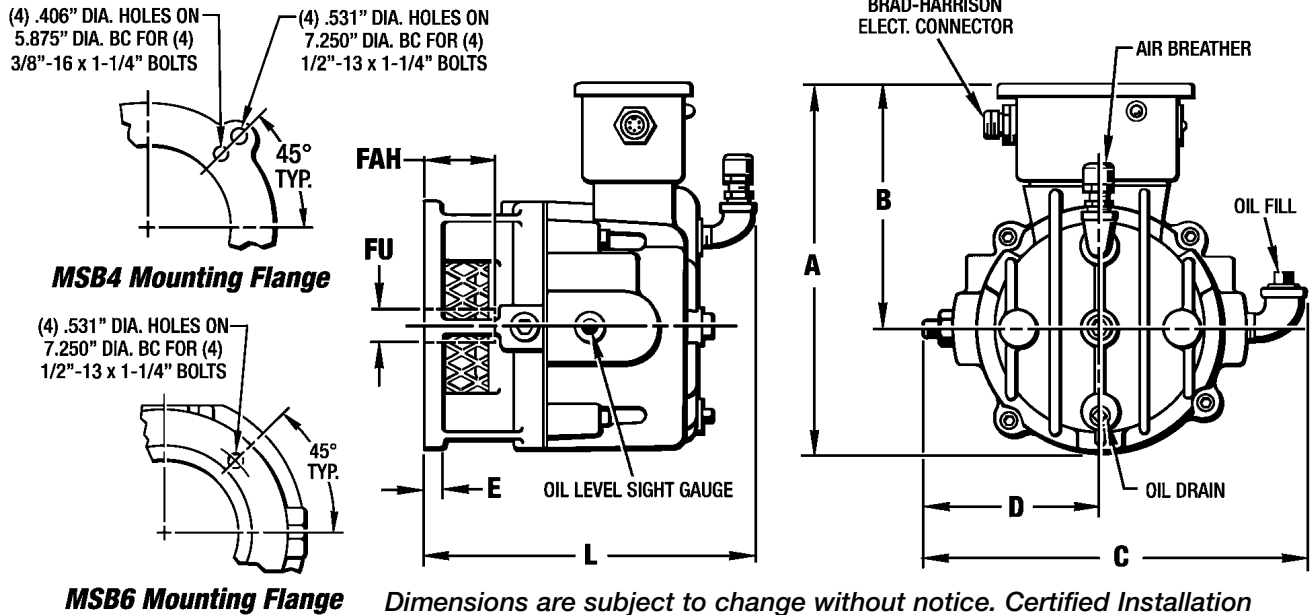

Figure 2.1 - Dimensions

Dimensions are subject to change without notice. Certified Installation Drawings are available upon request.

Std. Motor Shaft Tolerances:
.625" Dia & .875" Dia.
(+.0000" -.0005")

2-4 MSB4 AND MSB6 MagnaShear DIMENSIONS



BRAKE SIZE	MOTOR FRAME	QUILL BORE (Inches)			OVERALL DIMENSIONS (Inches)					
		FU	FAH		A	B	C	D	E	L
			MIN	MAX						
MSB4	182U	.875	1.37	2.89	10.25	6.88	10.75	5	.50	9.18
	184U									
	182T									
	184T									
	213U	1.125								
	215U									
	213T									
215T										
MSB6	213U	.875	1.62	4.25	12.58	7.56	12.72	6	.50	11.08
	215U									
	213T	1.125								
	215T									
	254U									
	256U	1.375								
	254T									
256T										

Std. Motor Shaft Tolerances:
 .875" Dia. (+.0000" -.0005")
 1.125" Dia. (+.0000" -.0005")
 1.375" Dia. (+.0000" -.0005")

Figure 2.2 - MSB4 and MSB6 Dimensions

Section 3 INSTALLATION

IMPORTANT SAFETY PRECAUTIONS

The *MagnaShear* Motor Brake units described in this manual must not be installed in any manner except as specified and must not be operated at speeds, horsepower loads or temperatures other than those specified in this manual.

Failure to limit the operation of the drive to the conditions specified could damage the unit or damage interconnected equipment and void the Warranty.

WARNING

BEFORE INSTALLATION OR ATTEMPTING ANY REPAIRS TO THE MOTOR BRAKE, OPEN THE DISCONNECTS TO THE DRIVE MOTOR. LOCK IT OUT TO AVOID THE POSSIBILITY OF PERSONAL INJURY.

3-1 RECEIVING THE *MagnaShear* MOTOR BRAKE

Check the brake for shortage or damage immediately after arrival. Prompt reporting to the carrier's agent, with notations made on the freight bill, will expedite satisfactory adjustment by the carrier.

A. Assembled Electric Brake Motor (EBM)

If your *MagnaShear* Motor Brake is shipped pre-assembled to a drive motor, it is filled with oil and ready to run except for installing the Air Breather (#45) and electrical wiring. (See Figure 3.7 and 3.8 for Electrical Wiring Diagram.)

NOTE:

Before shipment, the Air Breather (#45) is removed and a pipe plug put in its place. This is done to prevent oil spillage during shipment. In most cases this will be a red plastic plug. This plug must be removed and the Breather (#45) installed to prevent damage to the brake. The breather is taped to the motor shaft for shipment. Always check the oil level though, to see if the oil level is in the center of the Sight Gauge (#46). (See Section 4 - LUBRICATION.)

B. *MagnaShear* Motor Brake

The standard *MSB2*, *MSB4* & *MSB6* *MagnaShear* Motor Brakes has been completely assembled and filled with fluid. The Air Breather (#45), (4) Mounting Bolts and (4) Lockwashers) are usually shipped separate in a cloth bag tied to the brake unit.

A red plastic plug is installed in place of the Air Breather (#45) to prevent fluid from spilling out in shipment.

IMPORTANT - This red plastic plug must be removed and the Air Breather (#45) installed before operating your *MagnaShear* Motor Brake.

Also check the fluid level to see if any has spilled out in transit. **The fluid must be in the center of the Sight Gauge (#46).** See Section 4 - Lubrication. Add fluid if necessary.

The *MSB2* has a Fan (#120) which also serves as a Quill Clamping Device to clamp the Hub (#2) to the motor shaft. This Fan will just be tightened enough to keep it in position on the Hub (#2). You will have to loosen the (2) Soc. Hd. Screws (#273) in the Fan (#120) to insert the motor shaft into the quill end of the Hub (#2).

The *MSB4* & *MSB6* has a Locking Collar (#111) to clamp the Hub (#2) to the motor shaft. The Collar will just be tightened enough to keep it on the Hub (#2). You will have to loosen up the (2) screws in the Collar to slide the brake onto the motor shaft.

IMPORTANT - Make sure the motor shaft and motor mounting surfaces are thoroughly cleaned before installing the Brake. DO NOT USE ANY LUBRICANT ON THE MOTOR SHAFT.

3-2 VERIFYING MOTOR SPECIFICATIONS

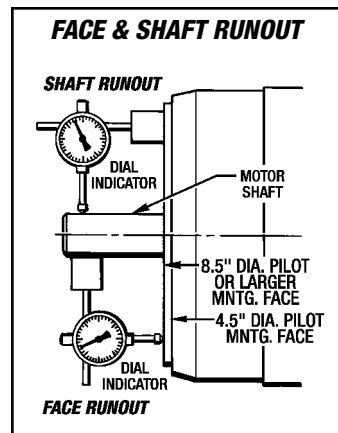

Figure 3.1 - Verifying Motor Specifications

The **Motor Manufacturer's Specifications** must be verified first to ensure the Motor Brake Oil Seal Reliability. (1) **Motor Shaft Runout** and (2) **Mounting Face Runout** need to be checked with a Dial Indicator as shown in Figure 3.1.

MAXIMUM ALLOWABLE T.I.R. (Inches)
(As Per NEMA MG 1 Standard)

Shaft Dia. Dimensions	Max. Allowable Shaft Runout	Max. Allowable Face Runout
.625" to 1.375"	.002"	.004"

CAUTION - T.I.R. in excess of this maximum will result in a potential leak condition.

3-3 INSTALLING THE *MagnaShear* BRAKE

A. MSB2 *MagnaShear* Only

(See Figures 3.2 and 3.3)

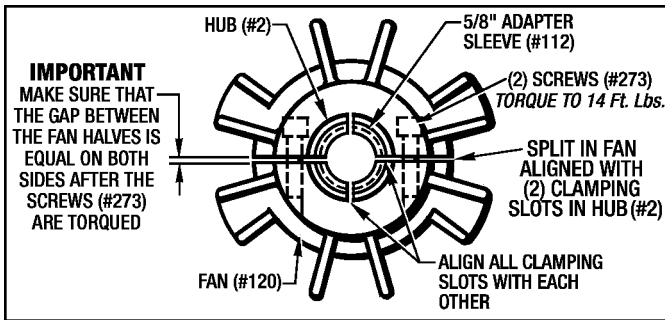

Figure 3.2 - Aligning Quill Clamping Slots (MSB2)

1. If you have a 5/8" Dia. motor shaft then there will be a 5/8" Adapter Sleeve (#112) in the bore of the Hub (#2). Make sure the Quill Locking Slots are all aligned with each other as shown in Figure 3.2.

Also if you have a 7/8" Dia. motor shaft, you won't have the Adapter Sleeve (#112), but two of the Quill Clamping Slots in the Hub (#2) has to be aligned with the split in the Fan (#120) as shown in Figures 3.2 and 3.3.

2. Push the Fan (#120) back against the small shoulder on the Hub (#2), then slide the Brake Unit onto the motor shaft as far as it will go. Align the (4) mounting holes with the motor and attach with (4) Mounting Bolts (#149) and (4) Lockwashers (#127). Finger tighten the (4) bolts. **Make sure the brake is snug against the motor face.**
3. Connect the electrical service to the Brad-Harrison Connector and actuate the brake coil to release the brake. (See Figures 3.7 & 3.8)

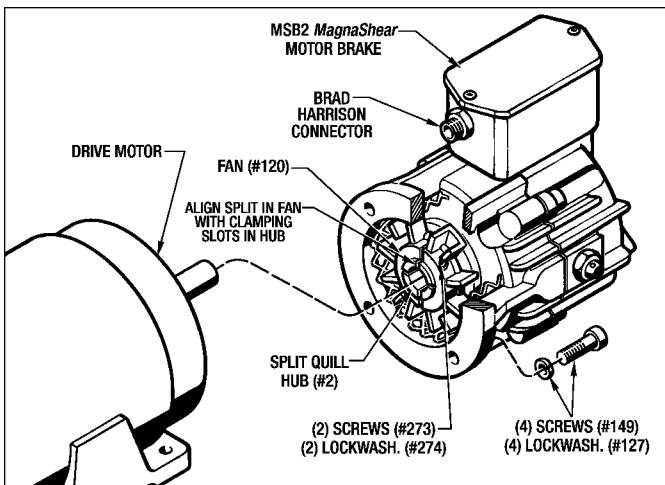

Figure 3.3 - Installing The MSB2 Onto The Drive Motor

4. Evenly torque the (2) Screws (#273) in the Fan (#120) to **14 Ft. Lbs.** Make sure that both slots in the Fan (#120) are equal as shown in Figure 3.2.

IMPORTANT - Make sure that both gaps in the Fan (#120) are the same after torquing the (2) Locking Screws (273).

NOTE - This will correctly center the brake and allow the brake to "Float" into position.

5. Turn the motor shaft by hand to make sure the bearings turn freely. Adjust if necessary.
6. Evenly torque the (4) Mounting Bolts (#149) in an opposite manner to **25 Ft. Lbs.**

B. MSB4 and MSB6 *MagnaShear*

(See Figures 3.4 and 3.5)

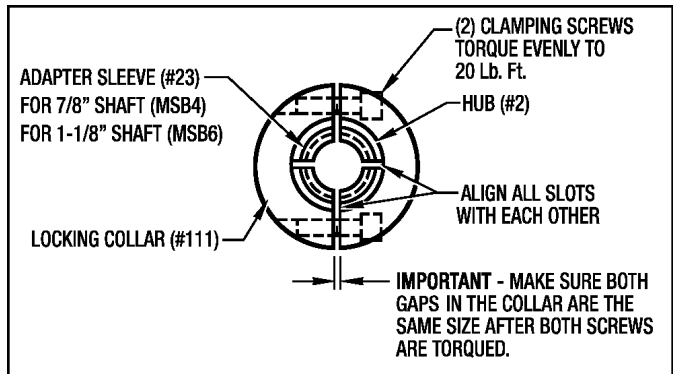

Figure 3.4 - Aligning Quill Clamping Slots (MSB4 & MSB6)

1. If you have an Adapter Sleeve (#23), make sure all the clamping slots are aligned with each other as shown in Figure 3.4.

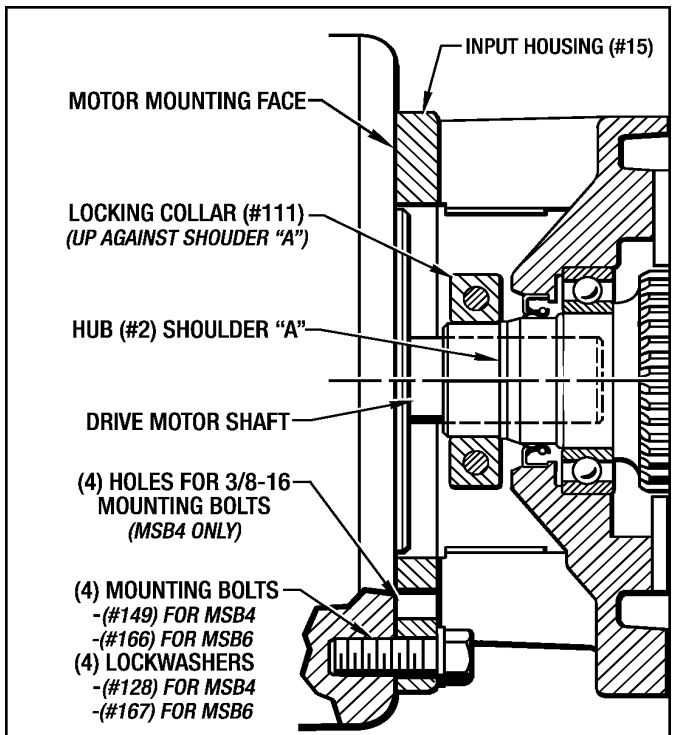

Figure 3.5 - Installing MSB4 & MSB6 Onto Drive Motor

If you don't have the Adapter Sleeve (#23), two of the slots in the Hub (#2) must be aligned with the (2) slots in the Clamping Collar (#111) as shown in Figure 3.4.

2. Push the Locking Collar (#111) back against the small shoulder "A" on the Hub (#2) as shown in Figure 3.5. Slide the Brake Unit onto the motor shaft as far as it will go. Align the (4) mounting holes with the motor and attach with (4) Mounting Bolts and (4) Mounting Lockwashers. Finger tighten the (4) bolts. **Make sure the brake is snug against the motor face.**
3. Connect the electrical service to the 5-Pin Brad-Harrison Connector and actuate the brake coil to release the brake. (See Figures 3.7 and 3.8)
4. Evenly torque the (2) Screws in the Clamping Collar (#111) to **20 Lb. Ft.**

IMPORTANT - Make sure that both slots in the Locking Collar (#111) are the same after torquing the (2) Screws.

NOTE - This will correctly center the brake and allow the brake to "Float" into position.

5. Turn the motor shaft by hand to make sure the bearings turn freely. Adjust if necessary.
6. Evenly torque the (4) Mounting Bolts in an opposite manner to the following torques:

(MSB4) Hex Hd. Screw (#149)
 5.875" Dia. Bolt Circle..... **25 Lb. Ft.**
 7.250" Dia. Bolt Circle..... **60 Lb. Ft.**

(MSB6) Hex Hd. Screw (#166)
 7.250" Dia. Bolt Circle..... **60 Lb. Ft.**

3-4 VERTICAL MOUNTING

Vertical Mounting vs. Horizontal Mounting is determined by the mounting angle. See Figure 3.6 above to determine the correct mounting configuration for your MagnaShear Motor Brake.

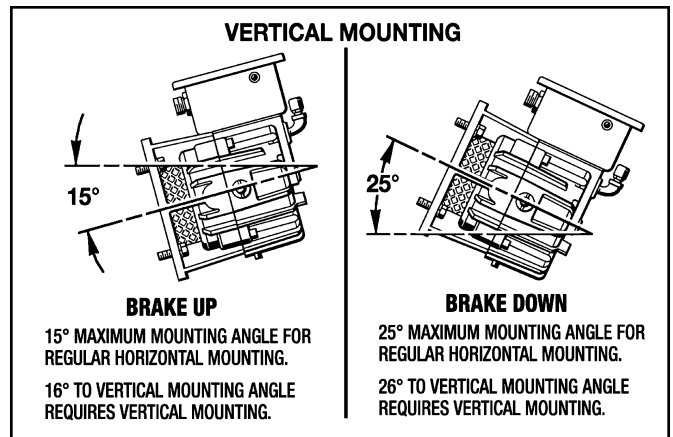

Figure 3.6 - Vertical Mounting

3-5 WIRING SPECIFICATIONS

(See Figure 3.7 and 3.8)

3-6 START-UP

Verify that the Brake Coil is wired correctly. Check to see if the Drive Motor is wired correctly, fuses are in place and the motor disconnect is turned on. Set-up preliminary settings on positioning switches to insure the brake will stop.

"Bump" the Drive Motor to check for correct rotation. If the rotation is incorrect change two of the phase wires and recheck rotation. Verify that the Brake Coil Indicator Light on the Conduit Box is **ON** while the drive motor is running. **(The indicator light comes on bright for .4 seconds and then dims after that.**

FUNCTION	BRAKE COIL ENERGIZED	
	On/Off	Ind.Light
RELEASE	ON	ON
BRAKING	OFF	OFF

Next, complete a cycle to insure that there are no interference problems within the system.

Set-up Position Switches as required.

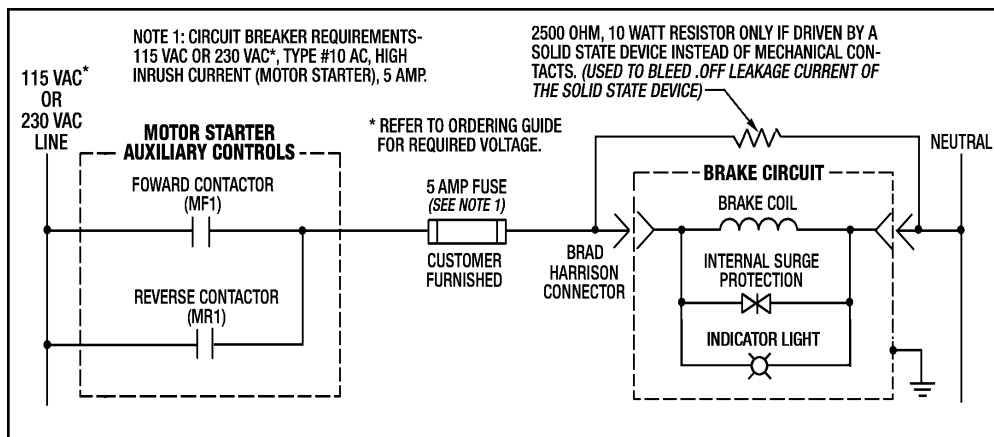

Figure 3.7 - Electrical Wiring Diagram

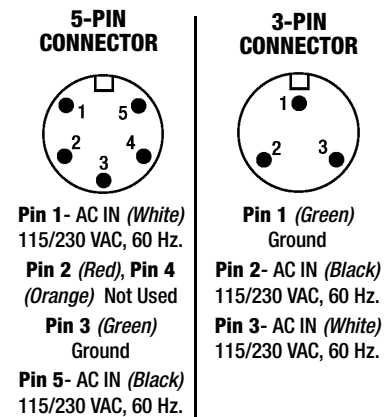

Figure 3.8 - Electrical Connector

Section 4 LUBRICATION

4-1 CHECKING THE OIL LEVEL

When the brake is installed and weekly thereafter, or until experience dictates otherwise, check the oil level. Always check the oil level with the brake at room temperature and while it is not running.

The **MagnaShear Motor Brakes** has an Oil Sight Gauge (#46) to visually check the fluid level. See *Figures 4.1, 4.2 and 4.3 for the location of this sight gauge.*

The oil level is to be at the center of this Sight Gauge (#46) for all models **with the drive motor turned off.**

4-2 OPERATING TEMPERATURES

A. Ambient Temperature

The standard oil used in the MagnaShear **Motor Brakes** was designed to operate in ambient temperatures up to 125° F. If the ambient temperature will fall outside of this range please contact Force Control Industries, Inc. for specific recommendations on proper lubricant and oil seals.

B. Oil Sump Temperature

The maximum recommended oil sump temperature is 200° F.

4-3 CHANGING THE OIL *(See Figures 4.1, 4.2 & 4.3)*

IMPORTANT

Always open the disconnects to the drive motor and lock them out before changing the oil.

Every three months completely drain the oil from the brake by removing the Drain Plug (#64). The Sight Gauge (#46) and Air Breather (#45) should also be removed and cleaned at this time.

The oil should be changed more frequently when used in harsh environments or high cyclic applications.

1. Remove Pipe Plug (#64) and drain out all the oil into a suitable container. Save or discard as conditions warrant. Replace the pipe plug when finished.
2. Remove the Pipe Plug (#62) and fill with fresh oil to the center of the sight Gauge (#46). Replace the pipe plug when finished.

CAUTION

Do not overfill the brake unit. Excess oil will cause the brake to over heat.

4-4 TYPE OF OIL

Use only Mobil Automatic Transmission Fluid ATF-210 (Type "F") or Mobil Multi-Purpose Automatic Transmission Fluid for most drives.

Other fluids may be specified for special applications.

Always use the type of oil specified on the Name Plate.

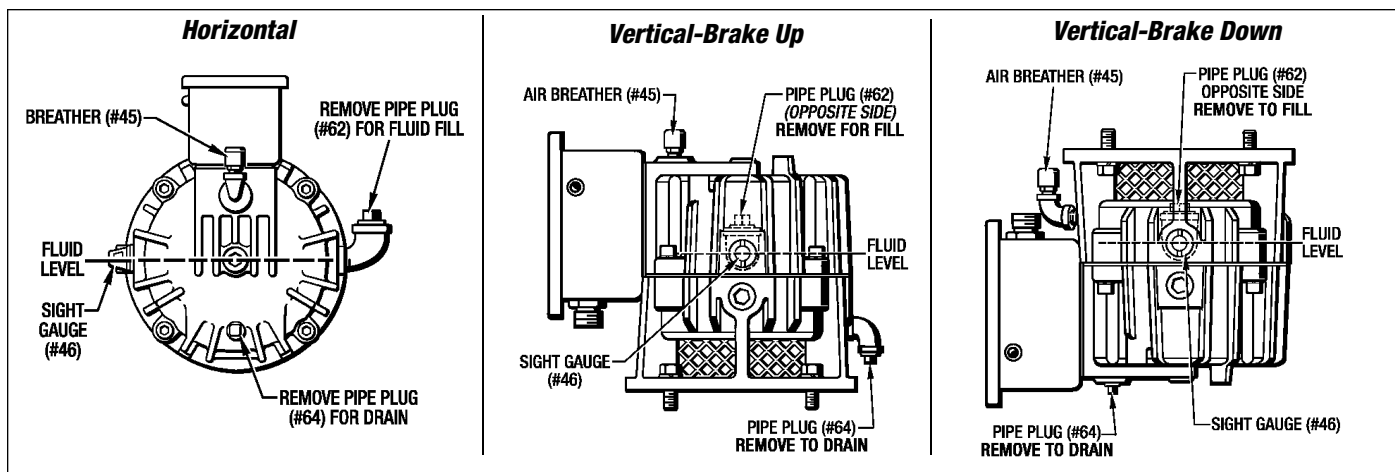

Figure 4.1 - Lubrication - MSB2

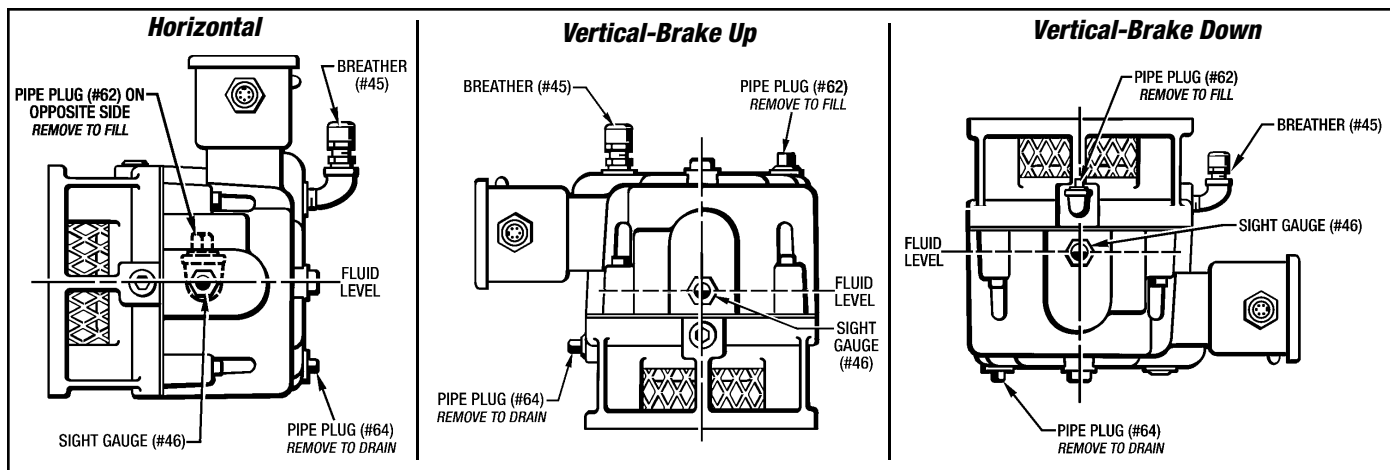

Figure 4.2 - Lubrication - MSB4 MagnaShear

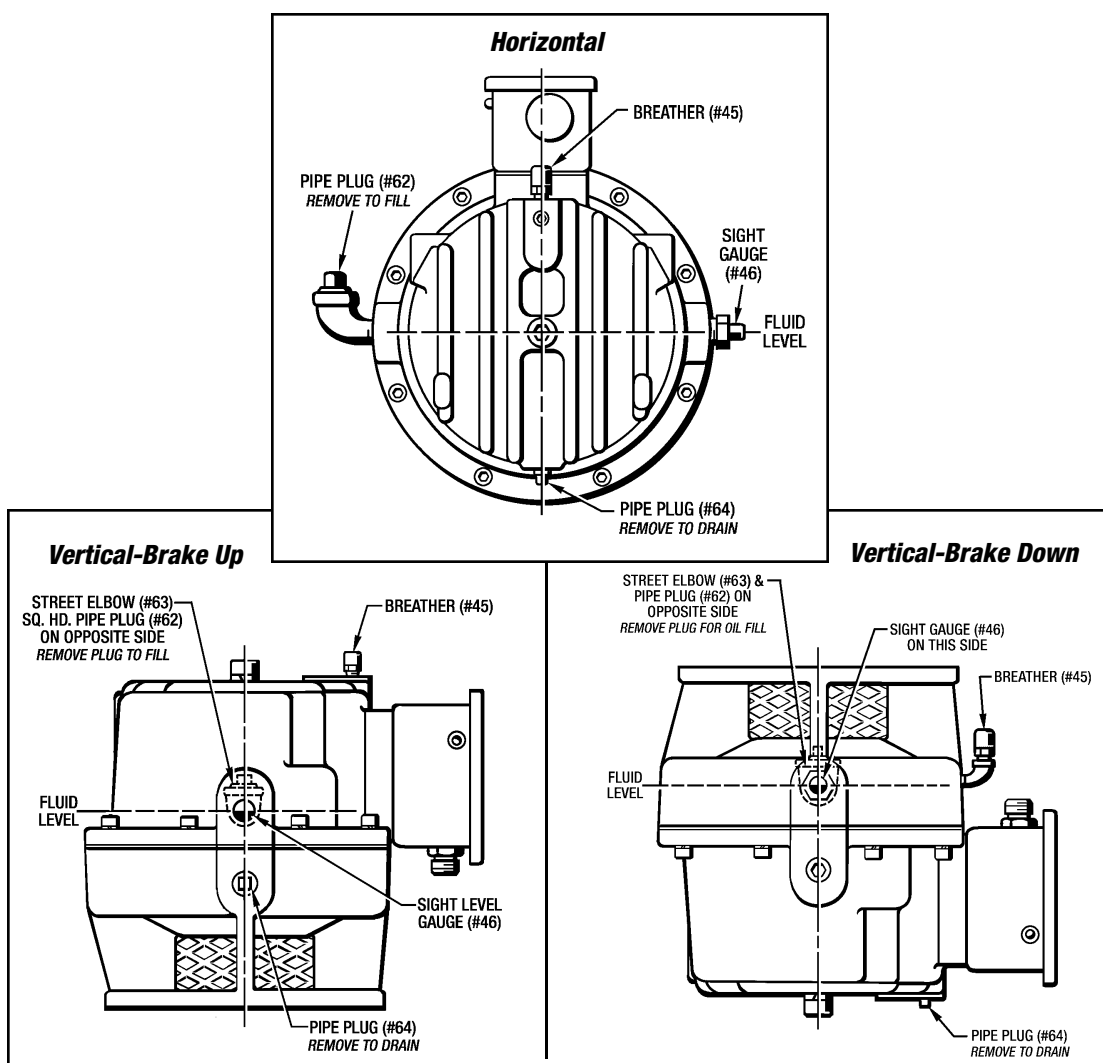

Figure 4.3 - Lubrication - MSB6 MagnaShear

Section 5 OPERATIONAL CHECKS

Make these Operational Checks with the **MagnaShear Motor Brake** shut down and completely assembled with the drive motor attached.

Provisions for manual operation checks must be made if the drive unit has been removed for service and repair. 115 or 230 VAC *, 60 Hz. electrical service is required to energize the coils. (See Figure 5.1 below for the Test Set-Up) * **Check Model Number for correct voltage.**

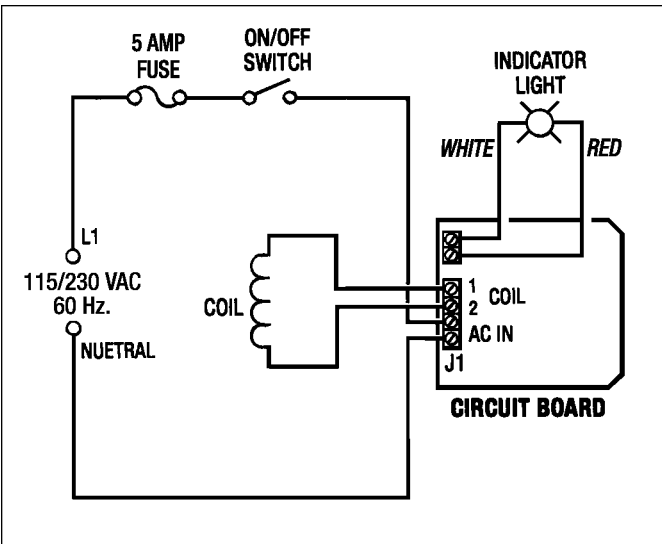

Figure 5.1 - Test Set-Up Electrical Schematic

5-1 CHECKING THE BRAKE OPERATION

To check the Brake Operation electrical power is not required to energize the coil since the **MagnaShear Motor Brake** has a normally spring loaded brake when

the coil is de-energized.

Disconnect the load to the motor. Install a torque wrench on the motor shaft and apply torque. The brake should slip at approximately the static torque of the brake. (Refer to page 2 for torque ratings.)

5-2 CHECKING THE BRAKE COIL OPERATION

1. Remove the cover from the Conduit Box (#405).
2. Disconnect the black and white power leads from the Brad-Harrison Cable Connector (# 416) to "AC In" on Terminal Strip J1. located on the Circuit Board (#400).
3. Connect the test power leads to "AC In" on J1. Turn the On/Off Switch to ON. The Power Indicator Light should come on bright for .4 seconds and then dim after that.
4. Manually turn the Drive Motor Output Shaft. If the shaft turns then the Brake Coil and Control Circuit is operating properly.

If it is not able to be turned, then the Brake Coil or Circuit Board is not functioning properly. (See Section 6 - Trouble Shooting.)

CAUTION

Physical damage or mal-function in the motor or brake stack can also prohibit shaft rotation.

Section 6 TROUBLESHOOTING

6-1 TROUBLESHOOTING CHART

PROBLEM	POSSIBLE CAUSE	REMEDY
1. Brake fails to engage properly.	Electrical control circuit. Faulty <i>MagnaShear</i> circuit board. Worn friction surfaces.	Check control circuit. Replace circuit board. Check disc stack for wear and replace if necessary.
2. Brake fails to release properly.	Electrical control circuit. Faulty <i>MagnaShear</i> circuit board. Faulty coil. Low voltage at coil.	Check control circuit. Replace circuit board. Replace coil. Check wire size and voltage.
3. Brake torque too high.	Excessive spring force. Low oil level.	Contact Force Control. Check oil level and add oil.
4. Brake torque too low	Inadequate spring force.	Contact Force Control.
5. Noise and vibration	Motor mounted on poor foundation.	Improve installation. Tighten mounting bolts
6. Drive overheats (200° F max.)	Brake fails to engage or disengage properly. Improper oil level.	See #1 and #2 above. Check oil level. Add/Drain as req'd.
7. Oil leakage.	Bad oil seal Gaskets. Poor ventilation.	Disassemble and replace. Tighten all external screws. Remove breather and clean.
8. Brake does not repeat.	Electrical control circuit. Faulty <i>MagnaShear</i> circuit board. * Oil temperature change. Machine resistance changed.	Check control circuit. Replace circuit board. Check temperature. Lubricate bearings.

* For installations requiring precise starting and stopping, operating temperatures are important. Operating temperatures between 115° F and 165° F are recommended.

6-2 TROUBLESHOOTING COILS

A. Coil Resistance Test

Remove the cover from the Junction Box (#405) and disconnect the (2) Coil Leads from both terminals on the Terminal Strip J1 located on the Circuit Board (#400).

Hook-Up a Meg-Ohmmeter to both coil leads as shown in Figure 6.1. Set the Meg-Ohmmeter to "Ohm" range and test Resistance at 500 VDC.

The Resistance should read as follows:

115 VAC Power*

MSB2 Coil Resistance.....47 Ohms \pm 10%
 MSB4 Coil Resistance.....47 Ohms \pm 10%
 MSB6 Coil Resistance.....23 Ohms \pm 10%

230 VAC Power*

MSB2 Coil Resistance.....188 Ohms \pm 10%
 MSB4 Coil Resistance.....188 Ohms \pm 10%
 MSB6 Coil Resistance.....92 Ohms \pm 10%

A reading outside of this range would indicate that the Coil is bad and needs to be replaced. See Section 7 for Coil Replacement.

NOTE:

A Hi-Pot Tester can be used for this test but do not exceed 1250 VDC.

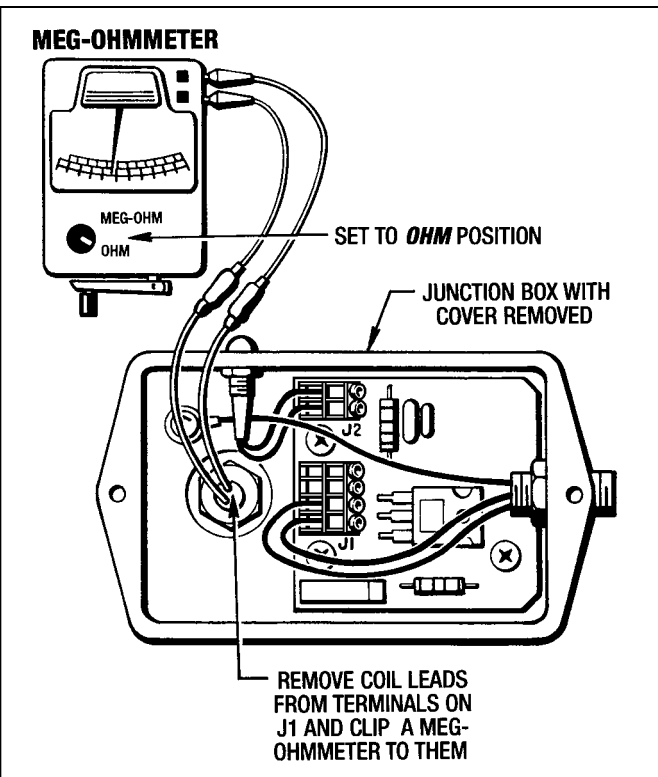

Figure 6.1 - Coil Resistance Testing

B. Coil Current Leakage Test

Remove the cover from the Junction Box (#405) and disconnect the (2) Coil Leads from both terminals on the Terminal Strip J1 located on the Circuit Board (#400).

Connect (1) alligator clip to both Coil Leads and the other one to Chassis Ground Screw (#426). (See Figure 6.2)

A reading of **10 Meg-Ohms or greater** indicates that the Coil is fine and does not need to be replaced. Anything much less would indicate that there is a short to ground and the Coil would need to be replaced. See Section 7 for Coil Replacement.

NOTE:

A Hi-Pot Tester can be used for this test but do not exceed 1250 VDC.

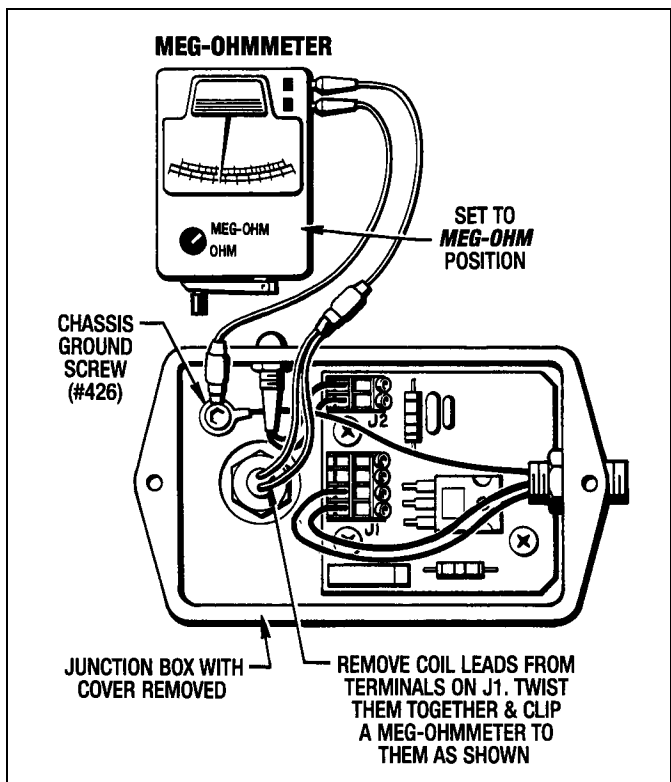

Figure 6.2- Coil Current Leakage Testing

* - Correct voltage is either 115 VAC or 230 VAC (See the Model Number for your correct voltage).

Section 7

REPAIR and REPLACEMENT

WARNING
SHUT-OFF AND LOCK-OUT ALL ELECTRICAL POWER BEFORE ATTEMPTING TO MAKE ANY REPAIRS TO THE BRAKE UNIT.

7-1 GENERAL INFORMATION

Unless the Motor Brake is to be completely overhauled, it should be disassembled only to the extent necessary to gain access to the worn or damaged parts.

During disassembly and reassembly procedure refer to the exploded view drawings in **Section 8** for a visual reference to all parts. They are as follows:

1. *Figure 8.1* - Electric Box and Circuit Board
2. *Figure 8.2* - MSB2 MagnaShear Motor Brake
3. *Figure 8.3* - MSB4 MagnaShear Motor Brake
4. *Figure 8.4* - MSB6 MagnaShear Motor Brake
5. *Figure 8.5* - MSB2 - Vertical Installation
6. *Figure 8.6* - MSB4 - Vertical Installation
7. *Figure 8.7* - MSB6 - Vertical Installation

7-2 CLEANING AND INSPECTION

Clean metal parts in a suitable solvent and dry with low pressure compressed air.

MSB2 - The Drive Plates (#12) and Shims (#986, #987 & #988) can be cleaned in a solvent but **DO NOT** clean the Friction Discs (#13) in solvent. Use only a clean, dry and lint-free rag to clean them. (Solvent will damage the friction material used on them.) Always keep the Friction Discs (#13) and Drive Plates (#12) in the same order as they were removed.

MSB4 and MSB6 - The Brake Stack (#41) can be taken apart and cleaned. Remove the Stack Retaining Washers on the end of the Retaining Pins. The MSB4 has (2) and the MSB6 has (4). The cleaning procedure and conditions are the same as the MSB2 above. Clean the Drive Plates in solvent and the Friction Discs with a clean, dry and lint free rag.

After cleaning inspect parts for cracks, distortion, scoring, nicks, burrs or any other damage that would affect the operation of the brake.

Pay particular attention to the Hub (#2) and the Oil Seal (#31) located in the Input Housing (#15). Check for any nicks, scratches or any damage that would cause leakage.

7-3 REPAIR OR REPLACEMENT

A fine stone or crocus cloth may be used to remove minor surface defects from parts if the operation or sealing action of the part is not affected. The use of coarser abrasives or other machining methods should not be attempted and damaged parts should be replaced.

Replacement is recommended for the following parts when needed:

1. Replace all Gaskets, O-Rings and Oil Seals removed at disassembly.
2. Replace Brake Stack as a complete Assembly.

7-4 MEASURING STACK HEIGHT

A. MSB2 MagnaShear

The Stack Height must be measured to determine whether or not the Brake Stack needs to be replaced. If it measures under the Minimum Worn Stack Height then the Brake Stack needs to be replaced. Also, if you are installing a new brake stack, it needs to be measured to determine the amount of shims required (See *Figure 7.1*)

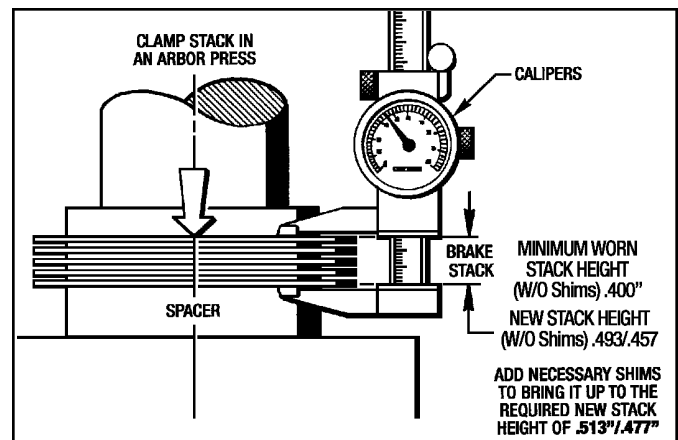

Figure 7.1 - Measuring Stack Height - MSB2

B. MSB4 and MSB6 MagnaShear

The Stack Height must be measured to determine whether or not the Brake Stack needs to be replaced. If it measures under the Minimum Worn Stack Height then the Brake Stack needs to be replaced. (See *Figure 7.2* on next page.)

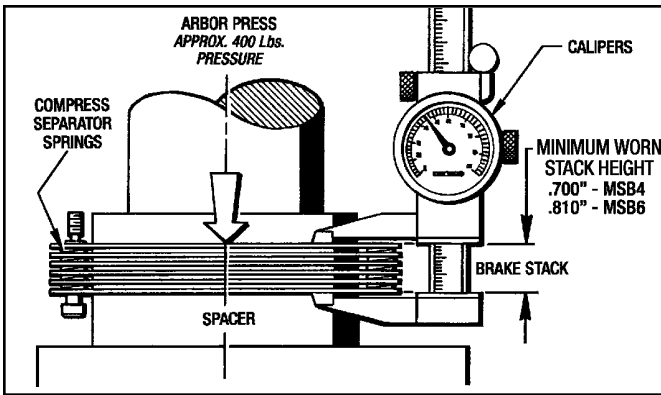

Figure 7.2 - Measuring Stack Height - MSB4 & MSB6

7-5 REPLACING MSB2 BRAKE STACK

(See Figures 7.3 and 8.2)

A. Disassembly

1. First drain all the oil from the unit into a suitable container. **See Section - 4 LUBRICATION** for location of drain plugs. Save or discard as condition warrants.
 2. Also disconnect the Brad Harrison Cable from the Electric Box (#405).
 3. Remove the (4) Screws (#169) and (4) Lockwashers (#129) from the End Housing (#9).
 4. Pull the End Housing (#9) away from the Input Housing (#15). Remove and discard the Gasket (#121).
5. Remove the (2) Button Hd. Screws (#181) that holds the brake stack together.
 6. Remove any Shims (#986, #987 & #988) that were required from the brake stack.
 7. Remove the complete Brake Stack off the Hub (#2). There will be (5) Drive Plates (#12), (4) Friction Discs (#13) and (8) Separator Springs (#17). Also remove the Thrust Plate (#5).
 8. Place the Brake Stack without any Separator Springs (#17), including any shims in an arbor press and measure the **Worn Stack Height** as described in **Section 7-4** to determine whether or not the Brake Stack needs to be replaced. (See Figure 7.1)

If the Brake Stack needs replaced then use the following procedure:

9. Measure the **New Brake Stack** with the same procedure as shown in Figure 7.1 to determine the amount of shims required. The normal shim requirement is .020".
10. Add any Shims necessary to bring the **Stack Height up to the Required Height of .513"/.477"**.

B. Reassembly

Make sure the Thrust Plate (#5), (2) Pins (#179) and (4) Pins (#176) are thoroughly cleaned and not damaged in any way.

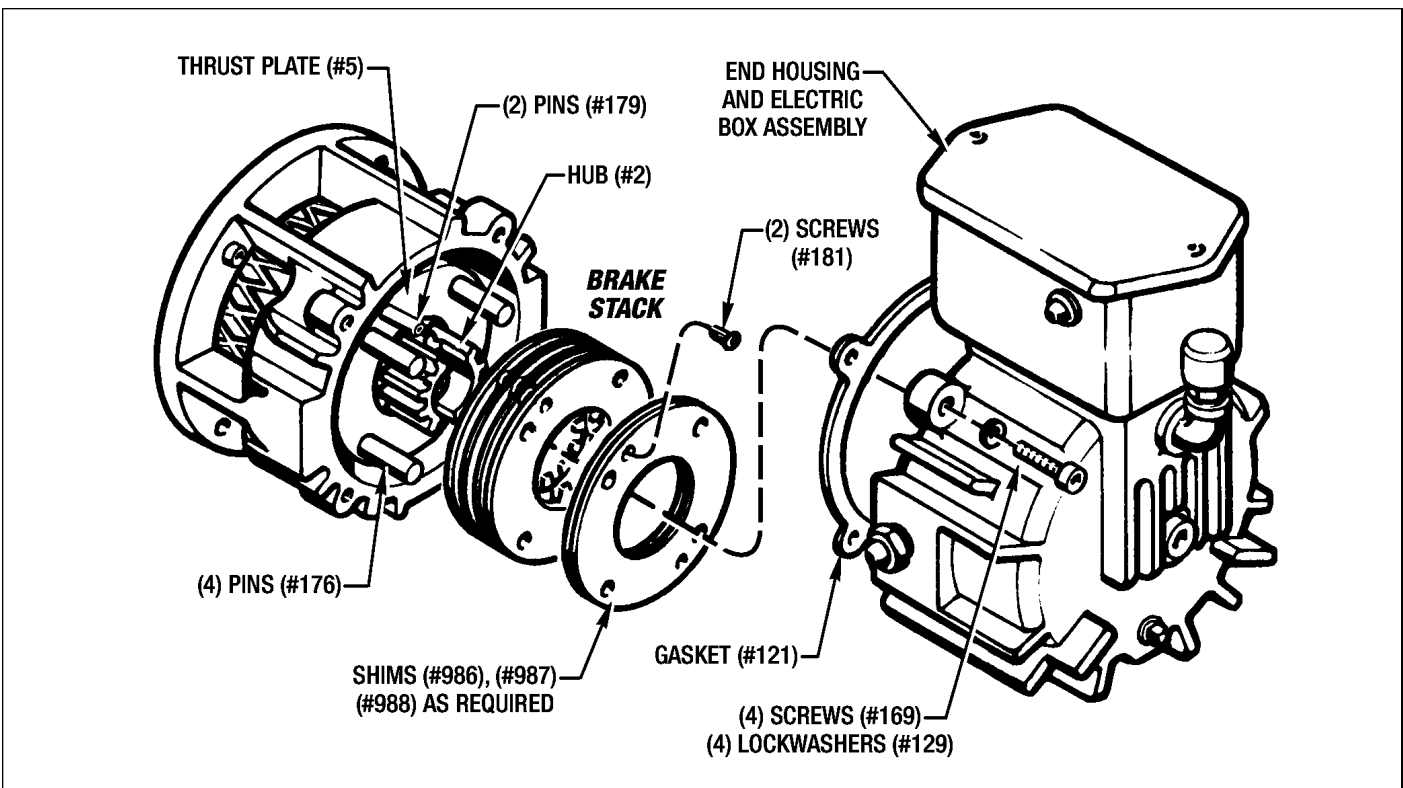

Figure 7.3 - Replacing the Brake Stack - MSB2 MagnaShear

1. First Install the Thrust Plate (#5) then a Drive Plate (#12) over the (4) Driver Pins (#176) and the (2) Pins (#179).
2. Install (2) Separator Springs (#17) on the (2) Pins (#179).
3. Next place a Friction Disc (#13) on the installed Drive Plate (#12).
4. Continue with this process until (5) Drive Plates (#12), (4) Friction Discs (#13) and (8) Separator Springs (#17) are installed. You will end up with a Drive Plate (#12) last.
5. Place any shims that are required for the correct stack height on last.
6. Install the (2) Button Hd. Screws (#181) into the (2) Pins (#179). **Use Primer T and Blue Loctite #242.**
7. Insert the (4) Screws (#169) along with (4) Lockwashers (#129) into the End Housing (#9).
Place a new Gasket (#121) on the mounting face of the End Housing (#9).
8. Attach the End Housing (#9) to the Input Housing (#15). **Torque the (4) Screws (#169) to 14 Ft. Lbs.**

7-6 REPLACING MSB4 & MSB6 BRAKE STACK

(See Figures 7.4, 8.3 and 8.4)

1. First drain all the oil from the unit into a suitable container. **See Section 4 - LUBRICATION** for location of drain plugs. Save or discard as condition warrants.
2. Also disconnect the Brad Harrison Cable from the Conduit Box (#405).
3. Remove the Screws (#72) and Lockwashers (#127) from the End Housing (#9). *There are (4) Screws and Lockwashers on the MSB4 Brake. The MSB6 Brake has (8) Screws and Lockwashers.*
4. Take the End Housing (#9) and Gasket (#121) or (#122) off. *The Gasket is (#121) for MSB4. For MSB6 the number is (#122).* Discard the Gasket.
5. The Brake Stack (#41) can now be removed by unscrewing the (4) shoulder bolts that attaches the drive plates to Housing (#15). Pull the Stack off the Hub (#2) spline and the (4) Pins (#176). (See Figure 7.4)
6. Place the Brake Stack (#41) in an arbor press and measure the Stack Height to determine whether or not the Brake Stack (#41) needs replaced. (See Section 7-4 and Figure 7.2)

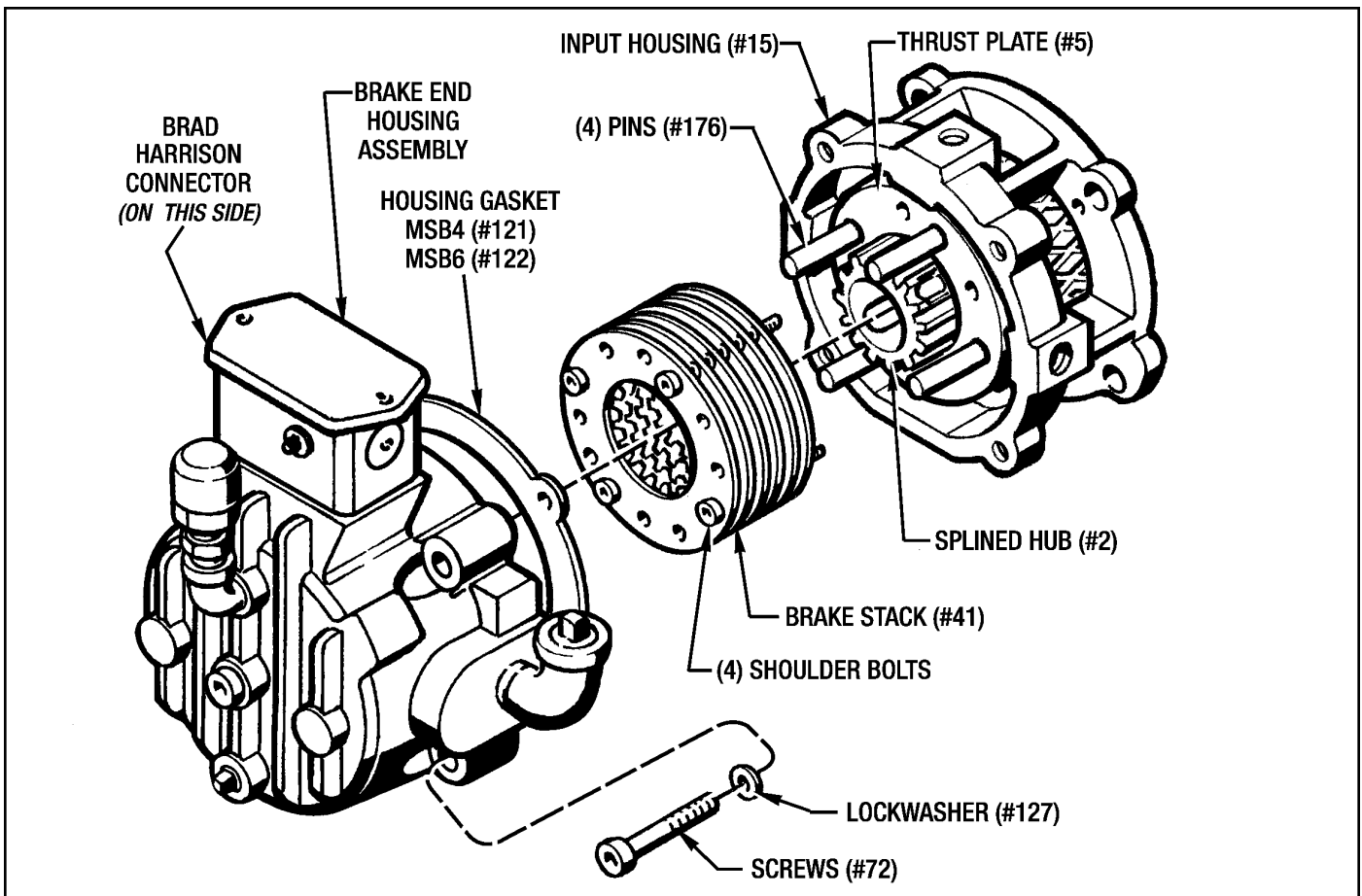

Figure 7.4 - Replacing MSB4 and MSB6 Brake Stack

FORCE CONTROL INDUSTRIES, INC.



MEX (55) 53 63 23 31 MTY (81) 83 54 10 18
QRO (442) 1 95 72 60 ventas@industrialmagza.com

- If the Brake Stack needs replaced then install a new stack onto the Hub (#2) and the (4) Pins (#176). Push it on as far as it will go and tighten the (4) shoulder bolts in the stack

NOTE: Make sure the teeth in the friction discs are aligned with each other so the Brake Stack (#41) will slide on to the Hub (#2) spline.

- If the Brake Stack is the only part that needs replaced then reassemble the End Housing Assembly back over the Brake Stack with a new Gasket (#121) or (#122). **Do not use any gasket sealant on this gasket.**

Tighten Screws (#72) to the following Torque:

MSB4 - 14 Ft. Lbs.

MSB6 - 25 Ft. Lbs.

- Replace drain plugs and refill with fresh oil as specified in **Section 4 - LUBRICATION.**

7-7 REPLACING CIRCUIT BOARD (#400)

(See Figure 7.5 and 8.1

- Take the cover off the Electric Box (#405).
- Disconnect all the wires from the (2) Terminal Strips J1 and J2 on the Circuit Board (#400).
- Remove the (3) Screws (#428) and (3) Nylon Washers (#431).
- Take the old Circuit Board (#400) off and replace it with a new one.

- Re-attach with (3) Screws (#428) and (3) Nylon Washers (#431). Re-connect the wires to J1 and J2 Terminal Strips.

- Replace the electric box cover.

7-8 REPLACING HOLDING COIL FOR MSB2

(See Figures 7.5, 7.6 and 8.2)

A. Disassembly

See **Section 7-5 REPLACING THE BRAKE STACK** and repeat **Steps 1 thru 4** to remove the End Housing (#9) from the Input Housing (#15).

- Remove the (2) Shoulder Bolts (#144) from the Armature Plate (#56).

CAUTION - Back these (2) Shoulder Bolts out in an even manner to release the spring pressure.

- Remove the Armature Plate (#56) and the Springs (#36) from the Pins (#119). See Figure 7.6 for spring quantity and location.
- Dis-connect the coil leads from J1 terminal strip located on the Circuit Board (#400). Also remove the compression nut from the Electrical Fitting (#415) and pry the rubber seal out of the fitting and off of the coil leads. (See Figure 7.5.)
- Remove Screw (#153) and Lockwasher (#275) from the End Housing (#9).
- Lift the Coil Assembly (#284) out of the End Housing.
- Remove and discard O-Ring (#103).

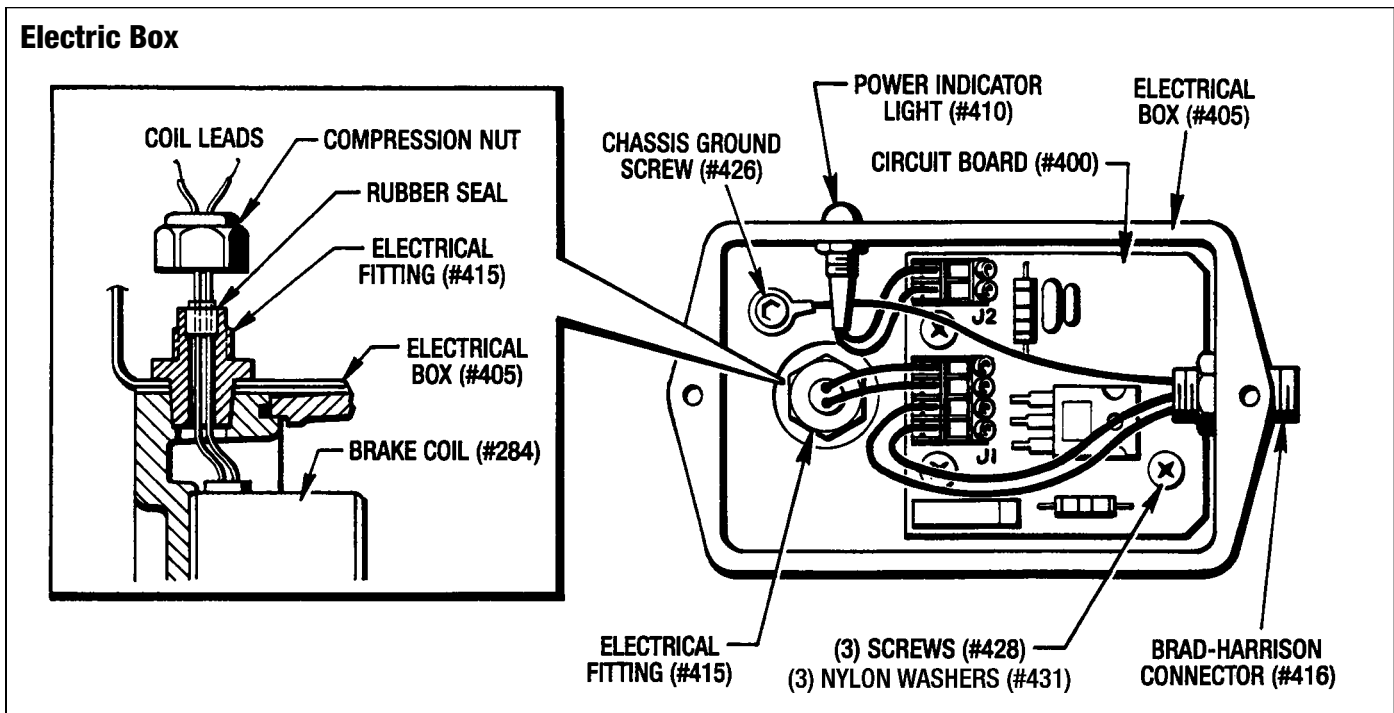

Figure 7.5 - Electric Box with Cover Removed

B. Reassembly

1. Lubricate a new O-Ring (#103) with white grease, or equivalent, and install it into the End Housing (#9) counterbore.
2. Place a new Holding Coil (#284) into the End Housing (#9), pushing the coil leads up through the Electrical Fitting (#415).
3. Attach the Coil (#284) with (1) Lockwasher (#275) and (1) Screw (#153). Make sure that the coil wires are at the top of the brake. **Torque to 60 Ft. Lbs.**
4. Place the rubber seal on the coil leads and pull the wires through, taking up all the slack in the wires. Seat the rubber seal into the threaded part of the Electrical Fitting (#415). Tighten down the compression nut. (See Figure 7.5)
5. Attach the coil leads to the Terminal Strip J1 on the Circuit Board (#400) and replace the cover on the Electrical Box (#405).
6. Set the End Housing (#9) so the Coil (#284) is facing upright. Place the correct number of Springs (#36) into the End Housing. (See Figure 7.6)

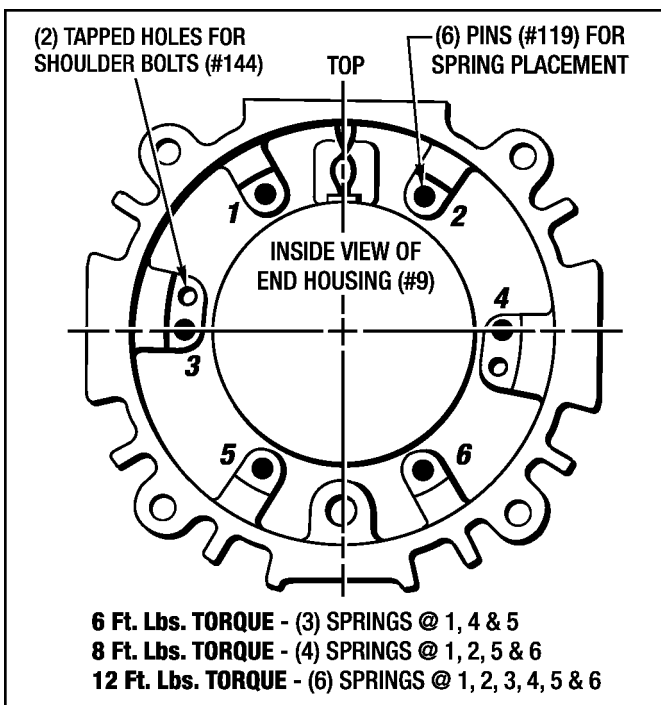

Figure 7.6 - Spring (#36) Placement For MSB2

7. Set the Armature Plate (#56) and Armature Ring (#58) in position on the Springs (#36). Make sure the (2) holes in the Armature Plate (#56) for the (2) Shoulder Bolts (#144) are aligned with the (2) tapped holes in the End Housing (#9) as shown in Figure 7.6.

8. Install the (2) Shoulder Bolts (#144). Use **Primer T and Blue Loctite #242** on the threads.
9. Insert the (4) Screws (#169) along with (4) Lockwashers (#129) into the End Housing (#9).

Place a new Gasket (#121) on the mounting face of the End Housing (#9).

10. Attach the End Housing (#9) to the Input Housing (#15). **Torque the (4) Screws (#169) to 14 Ft. Lbs.**

7-9 REPLACING HOLDING COIL FOR MSB4 & MSB6 (See Figures 7.5, 7.7, 8.3 or 8.4)

A. Disassembly

See **Section 7-6** and repeat **Steps 1 thru 4** to remove the End Housing (#9) from the Input Housing (#15).

(MSB4 Only)

1. Remove the (2) Shoulder Bolts (#114) from the Armature Plate (#56).

CAUTION - Back these (2) Shoulder Bolts out in an even manner to release the spring pressure.

(MSB6 Only)

1. Remove the (4) Shoulder Bolts (#138) from the Armature Plate (#56).

CAUTION - Back these (4) Shoulder Bolts out in an even manner to release the spring pressure.

(MSB4 and MSB6)

2. Remove the Armature Plate (#56) and the Armature Ring (#58) plus the Springs (#36).
3. Dis-connect the coil leads from J1 terminal strip located on the Circuit Board (#400). Also remove the compression nut from the Electrical Fitting (#415) and pry the rubber seal out of the fitting and off of the coil leads. (See Figure 7.5.)
4. Remove Screw (#153) and Lockwasher (#275) for MSB4 and (#128) for MSB6 from the End Housing (#9).
5. Lift the Coil Assembly (#284) out of the End Housing.
6. Remove and discard O-Ring (#103) for MSB4 and (#130) for MSB6.

B. Reassembly

1. Lubricate a new O-Ring (#103) for MSB4 or (#130) for MSB6 with white grease, or equivalent, and install it into the End Housing (#9) counterbore.
2. Place a new Holding Coil (#284) into the End Housing (#9), pushing the coil leads up through the Electrical Fitting (#415).

- Attach the Coil (#284) with Screw (#153) and Lockwasher (#275) for MSB4 or (#128) for MSB6.

MSB4 - Torque Screw (#153) to **60 Ft. Lbs.**

MSB6 - Torque Screw (#153) to **120 Ft. Lbs.**

- Place the rubber seal on the coil leads and pull the wires through, taking up all the slack in the wires. Seat the rubber seal into the threaded part of the Electrical Fitting (#415). Tighten down the compression nut. (See Figure 7.5)
- Attach the coil leads to the Terminal Strip J1 on the Circuit Board (#400) and replace the cover on the Electrical Box (#405).
- Set the End Housing (#9) so the Coil (#284) is facing upright. Place the correct number of Springs (#36) into the End Housing. (See Figure 7.7)

(MSB6 Only)

- Set the Armature Plate (#56) and Armature Ring (#58) in position on the Springs (#36). Make sure the (4) holes in the Armature Plate (#56) for the (4) Shoulder Bolts (#138) are aligned with the (4) tapped holes in the End Housing (#9) as shown in Figure 7.7.
- Install the (4) Shoulder Bolts (#138). Use **Primer T and Blue Loctite #242** on the threads.
- Place a new Gasket (#122) on the mounting face of the End Housing (#9).
- Attach the End Housing (#9) to the Input Housing (#15) with (8) Screws (#72) and (8) Lockwashers (#127). **Torque the (8) Screws (#72) to 25 Ft. Lbs.**

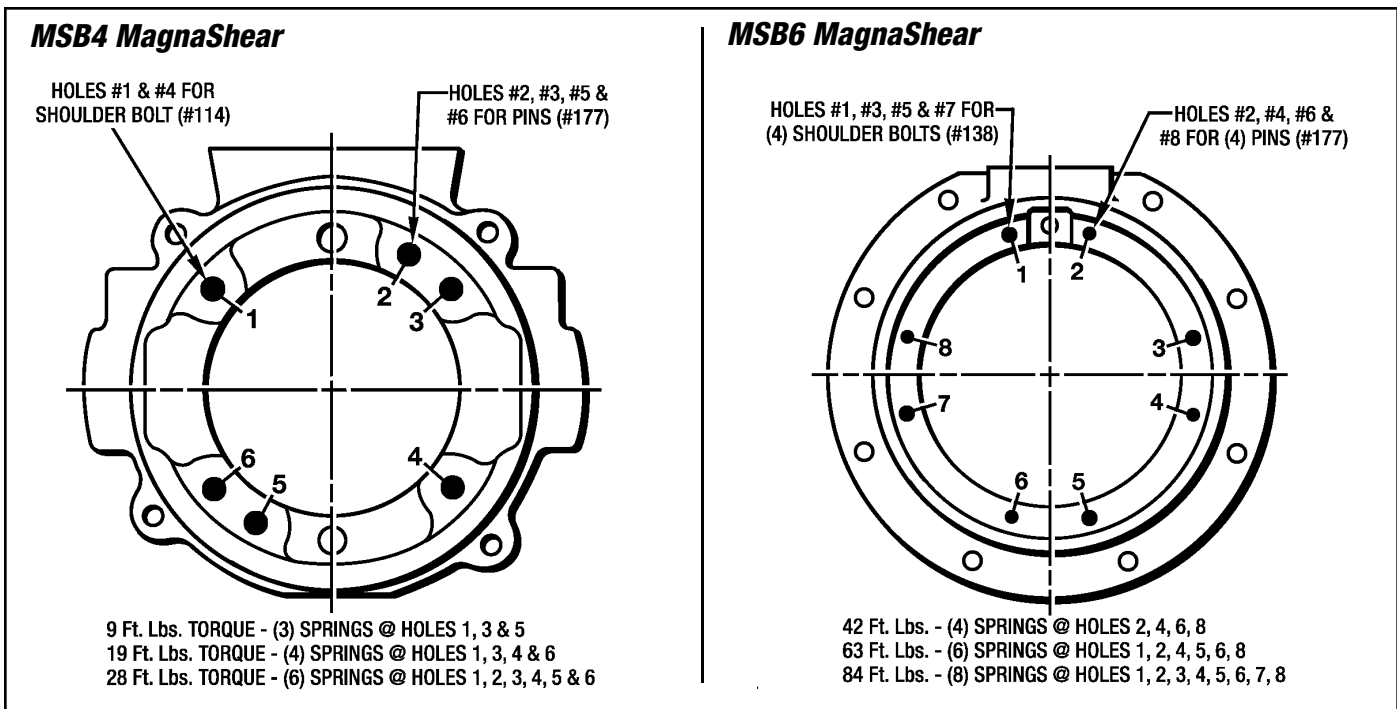

Figure 7.7 - Spring Placement for MSB4 and MSB6

(MSB4 Only)

- Set the Armature Plate (#56) and Armature Ring (#58) in position on the Springs (#36). Make sure the (2) holes in the Armature Plate (#56) for the (2) Shoulder Bolts (#114) are aligned with the (2) tapped holes in the End Housing (#9) as shown in Figure 7.7.
- Install the (2) Shoulder Bolts (#114). Use **Primer T and Blue Loctite #242** on the threads.
- Place a new Gasket (#121) on the mounting face of the End Housing (#9).
- Attach the End Housing (#9) to the Input Housing (#15) with (4) Screws (#72) and (4) Lockwashers (#127). **Torque the (4) Screws (#72) to 14 Ft. Lbs.**

7-10 REPLACING OIL SEAL & BEARING FOR MSB2

(See Figures 7.8, 8.1 and 8.2)

A. Disassembly

- First drain all the oil from the unit into a suitable container. **See Section 4 - LUBRICATION** for location of drain plugs. Save or discard as condition warrants.
- Also disconnect the Brad Harrison Cable from the Electric Box (#405).
- Loosen the (2) Screws (#273) in the Fan (#120).
- Remove the (4) Motor Mounting Screws (#149) and (4) Lockwashers (#127) and pull the Brake Assembly off the motor flange and motor shaft.

5. If you have a 5/8" Dia. motor shaft then pull the Adapter Sleeve (#112) out of the Hub (#2) bore.
6. Take the Fan (#120) off the Hub (#2).
7. Remove the End Housing (#9) and Brake Stack with the same procedure as described in **Section 7-5, Steps 3 to 7 in Disassembly.**
8. Remove the Bearing Retainer Screw (#168) and Flat Washer (#170).
9. Apply a little white grease to the input end of the Hub (#2) and pull it and the Bearing (#20) out of the Input Housing (#15).

CAUTION - If the Oil Seal (#31) is not to be replaced, be very careful not to damage the sealing lip.

10. Remove the Bearing (#20) from the Hub (#2) with a bearing puller if it is to be replaced.
11. Push the Oil Seal (#31) out of the Input Housing (#15) with an arbor press.

B. Reassembly

1. Clean out the oil seal bore and lightly coat the bore with **Permatex #3D Sealant**. Press the Oil Seal (#31) into the bore with an arbor press until it is seated. Clean off any excess sealant.

CAUTION - Be very careful not to get any sealant on the rubber sealing lip.

2. Clean off the OD of the Hub (#2) where the Bearing (#20) will be seated with **Loctite Primer T**. Also clean the ID of the Bearing (#20) with **Loctite Primer T**.
3. Apply **Green Loctite #609** to the ID of Bearing (#20) and install it on to the Hub (#2) with an arbor press until it is completely seated on the hub shoulder. Clean off any excess Loctite.
4. Apply a little white grease to the lip of the Oil Seal (#31) and to the mating surface of the Hub (#2).
5. Carefully insert the Hub (#2) into the Oil Seal (#31) until the Bearing (#20) is completely seated in the bearing bore.
6. Install the Flat Washer (#170) and Screw (#168) into the Input Housing (#15). Use **Loctite Primer T** and **Blue Loctite #242** on the threads.
7. Replace the Thrust Plate (#5), Complete Brake Stack and End Housing Assembly with the same procedure as described in **Section 7-5, Steps 1 thru 8 in the Reassembly Section.**

NOTE: This next Step #8 only applies to motors that have a 5/8" Dia. shaft. If your motor has a 7/8" dia. shaft, then skip to Step #9.

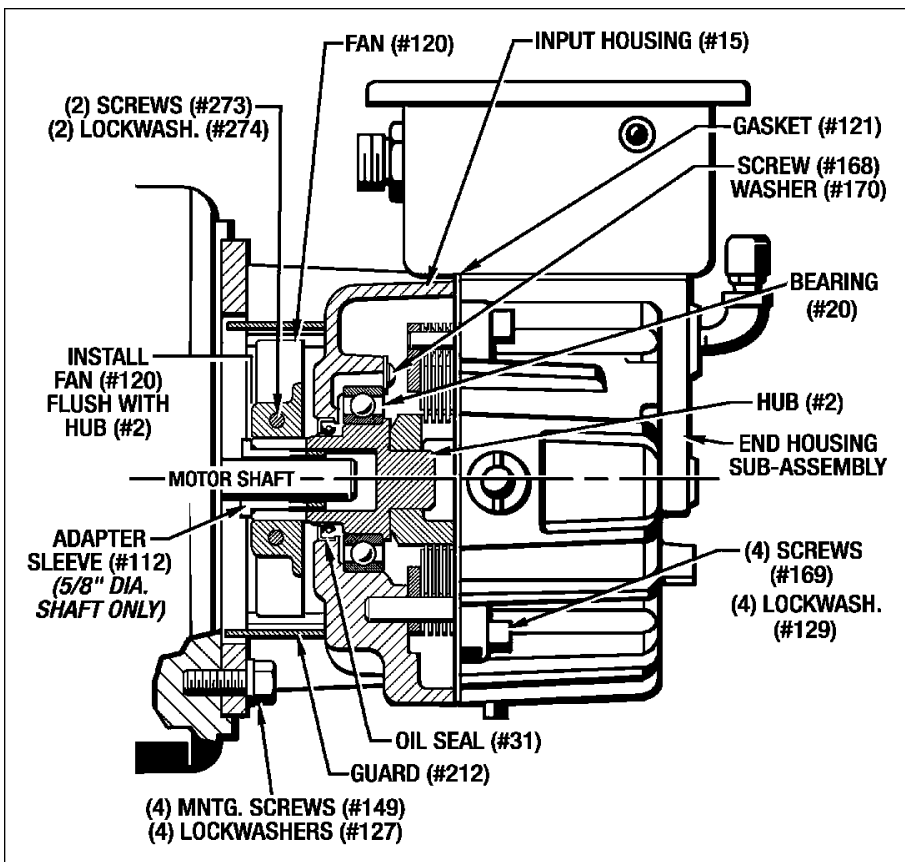

8. Insert the Adapter Sleeve (#112) into the Hub (#2) bore as far as it will go.

9. Position the Fan (#120) on the Hub (#2) up against the shoulder as shown in Figure 7.8 and **just finger tighten** the (2) Screws (#273).

NOTE: Make sure the Quill Clamping Slots are aligned with each other as shown in Figures 3.2 and 3.3 in Section 3 - Installation.

10. Slide the Brake Unit onto the motor shaft as far as it will go. Align the (4) mounting holes with the motor and attach with (4) Mounting Bolts (#149) and (4) Lockwashers (#127). Finger tighten the (4) bolts at this time. **Make sure the brake is snug against the motor face.**

11. Connect the electrical service to the Brad-Harrison Connector and actuate the brake coil to release the brake.

12. Evenly torque the (2) Screws (#273) in the Fan (#120) to **14 Ft. Lbs.** Make sure that both gaps in the Fan (#120) are equal as shown in Figure 3.1.

Figure 7.8 - Installing MSB2 Brake Back On The Motor

FORCE CONTROL INDUSTRIES, INC.



MEX (55) 53 63 23 31
QRO (442) 1 95 72 60

MTY (81) 83 54 10 18
ventas@industrialmagza.com

NOTE - This will correctly center the brake and allow the brake to “Float” into position.

13. Turn the motor shaft by hand to make sure the bearings turn freely. Adjust if necessary.
14. Evenly torque the (4) Mounting Bolts (#149) in an opposite manner to **25 Ft. Lbs.**

7-11 REPLACING OIL SEAL AND BEARING FOR MSB4 AND MSB6 (See Figures 7.9, 8.3 and 8.4)

A. Disassembly

1. First drain all the oil from the unit into a suitable container. **See Section 4 - LUBRICATION** for location of drain plugs. Save or discard as condition warrants.
2. Also disconnect the Brad Harrison Cable from the Electric Box (#405).
3. Loosen the (2) Screws in the Locking Collar (#111).
4. Remove the (4) Motor Mounting Screws and (4) Lockwashers and pull the Brake Assembly off the motor flange and motor shaft.
5. If you have an Adapter Sleeve (#23) in the Hub (#2) bore, pull it out.
6. Take the Locking Collar (#111) off the Hub (#2).
7. Remove the Screws (#72) and Lockwashers (#127)

from the End Housing (#9). There are (4) Screws and Lockwashers on the MSB4 Brake. The MSB6 Brake has (8) Screws and Lockwashers.

8. Take the End Housing (#9) and Gasket (#121) or (#122) off. *The Gasket is (#121) for MSB4. For MSB6 the number is (#122).* Discard the Gasket.
9. The Brake Stack (#41) can now be removed by unscrewing the (4) shoulder bolts that attaches the drive plates to Housing (#15). Pull the Stack off the Hub (#2) spline and the (4) Pins (#176). (See Figure 7.4)
10. Remove the Bearing Retainer Screw (#168) and Flat Washer (#170).
11. Apply a little white grease to the input end of the Hub (#2) and pull it and the Bearing (#20) out of the Input Housing (#15).

CAUTION - If the Oil Seal (#31) is not to be replaced, be very careful not to damage the sealing lip.

12. Remove the Bearing (#20) from the Hub (#2) with a bearing puller if it is to be replaced.
13. Push the Oil Seal (#31) out of the Input Housing (#15) with an arbor press.

B. Reassembly

1. Clean out the oil seal bore and lightly coat the bore with **Permatex #3D Sealant**. Press the Oil Seal (#31) into the bore with an arbor press until it is seated. Clean off any excess sealant.

CAUTION - Be very careful not to get any sealant on the rubber sealing lip.

2. Clean off the OD of the Hub (#2) where the Bearing (#20) will be seated with **Loctite Primer T**. Also clean the ID of the Bearing (#20) with **Loctite Primer T**.

3. Apply **Green Loctite #609** to the ID of Bearing (#20) and install it on to the Hub (#2) with an arbor press until it is completely seated on the hub shoulder. Clean off any excess Loctite.

4. Apply a little white grease to the lip of the Oil Seal (#31) and to the mating surface of the Hub (#2).

5. Carefully insert the Hub (#2) into the Oil Seal (#31) until the Bearing (#20) is completely seated in the bearing bore.

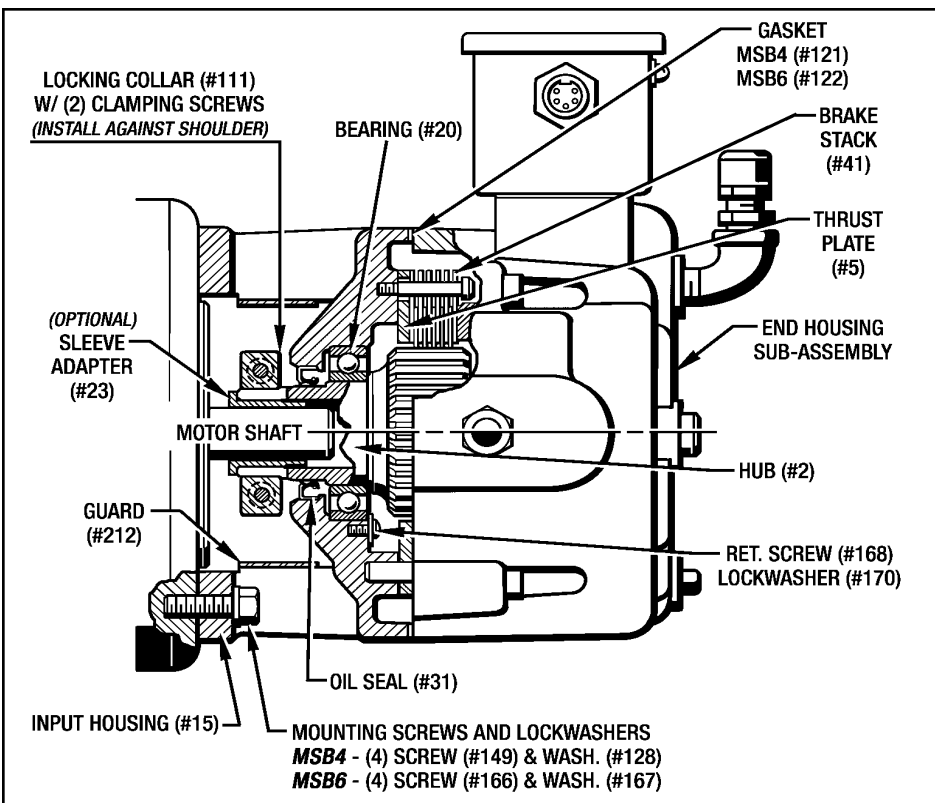

Figure 7.9 - Installing MSB4 and MSB6 Back On Motor

6. Install the Flat Washer (#170) and Screw (#168) into the Input Housing (#15). Use **Loctite Primer T** and **Blue Loctite #242** on the threads.

7. Replace the Thrust Plate (#5)

8. Install the Brake Stack onto the Hub (#2) and the (4) Pins (#176). Push it on as far as it will go and tighten the (4) shoulder bolts in the stack

NOTE: Make sure the teeth in the friction discs are aligned with each other so the Brake Stack (#41) will slide on to the Hub (#2) spline.

9. Install the End Housing Assembly back over the Brake Stack with a new Gasket (#121) or (#122). **Do not use any gasket sealant on this gasket.**

Tighten Screws (#72) to the following Torque:

MSB4 - 14 Ft. Lbs.

MSB6 - 25 Ft. Lbs.

10. If it applies, insert the Adapter Sleeve (#23) into the Hub (#2) bore as far as it will go.

11. Push the Locking Collar (#111) on to the Hub (#2) up against the shoulder as shown in *Figure 7.9* and **just finger tighten** the (2) Screws at this time.

Also make sure the Quill Clamping Slots are aligned with each other as shown in *Figures 3.4 and 3.5* in **Section 3 - Installation.**

12. Slide the Brake Unit onto the motor shaft as far as it will go. Align the (4) mounting holes with the motor and attach with (4) Mounting Bolts and (4) Lockwashers. For the MSB4 the Bolts are (#149) and the Lockwasher is (#128) and for the MSB6 the Bolts are (#166) and the Lockwasher is (#167)

Finger tighten the (4) bolts at this time. **Make sure the brake is snug against the motor face.**

13. Connect the electrical service to the 5-Pin Brad-Harrison Connector and actuate the brake coil to release the brake.

14. Evenly torque the (2) Screws in the Locking Collar (#111) to **20 Ft. Lbs.** Make sure that both splits in the Locking Collar (#111) are equal as shown in *Figure 3.4.*

NOTE - This will correctly center the brake and allow the brake to “**Float**” into position.

15. Turn the motor shaft by hand to make sure the bearings turn freely. Adjust if necessary.

16. Evenly torque the (4) Mounting Bolts in an opposite manner to the following torques:

MSB4 - 25 Ft. Lbs.

MSB6 - 60 Ft. Lbs.

7-12 FINAL REASSEMBLY PROCEDURE

The **Final Reassembly Procedure** is as follows for any Replacement Procedures described in this Section where the Brake had to be disassembled.

1. Replace any pipe plugs or fittings removed at disassembly and fill with fresh transmission fluid as described in **Section 4 - Lubrication.**
2. Make an Operational Check to make sure that everything is properly reassembled. **See Section 5 - Operational Checks.**

Section 8

ILLUSTRATED PARTS LIST

8-1 GENERAL INFORMATION

This section illustrates, lists and describes all parts for the **MSB2, MSB4 & MSB6 MagnaShear Motor Brake**. Parts are identified on the exploded views with Part Reference Numbers. These Numbers correspond to the Part Reference Number given in the Parts Lists. The Part Name and Quantity Used is also given in the Parts List. This Part Reference Number, Part Name and Quantity should be used when ordering Replacement Parts.

8-2 DRIVE MOTORS

The Drive Motors used with these **MagnaShear Motor Brakes** are standard motors and may be repaired or replaced by any qualified Motor Re-build Facility or Supplier.

8-3 FACTORY REBUILD SERVICE

Reconditioning Service is offered by Force Control Industries, Inc. at the factory. A complete factory rebuild will be 50% the cost of a new unit if the housings are reusable. If Housings need to be replaced, there will be an additional cost.

Contact Force Control Industries, Inc. for authorization and shipping instruction before returning a drive unit for this service. Force Control cannot be responsible for units returned to the factory without prior notice and authorization.

Care must be given to the packing of returned drives. Always protect mounting feet by attaching to a skid.

Shipment-damaged drives always delays repairs. It is usually impossible to recover damage costs from the carrier. When possible, describe the problem experienced on your shipping papers.

Return to: **Force Control Industries, Inc.**

**3660 Dixie Highway
Fairfield, Ohio 45014**

Phone: (513) 868-0900

Fax: (513) 868-2105

E-Mail: info@forcecontrol.com

8-4 ORDERING REPLACEMENT PARTS

When ordering replacement parts, please specify all of the following information:

1. Brake Model Number (On the Name Plate.)
2. Brake Serial Number (On the Name Plate.)
3. Part Reference Number (From the parts list or exploded view drawing.)
4. Part Name (From the parts list.)
5. Quantity (From the parts list.)
6. Complete Shipping Information.

Failure to include information for items 1 through 6 will only delay your parts order. Unless another method is specified for item 6, parts weighing less than 150 Lbs. will be shipped United Parcel Service. Parts weighing more than 150 Lbs. will be shipped Motor Freight. Air freight and other transportation services are available but only if specified on your order.

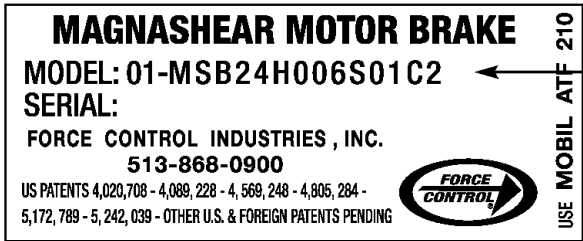

8-5 NAME PLATE AND MODEL NUMBER

The Name Plate shown is located on the lower end of the End Housing (#9).

The Example shown is a size MSB2, 4-1/2" Motor Pilot Dia., Horizontal Mounting, 6 Lb. Ft. Torque, No Manual Release, 7/8" Collet Bore Dia., 115 VAC, Connector located on front side of Conduit Box. and with an Engineering Revision of 2.

A. MSB2 MagnaShear

01-MSB	2	4					S					
1	2	3	4	5	6	7	8	9	10	11		

Size (1) _____

2 = MSB2

Motor Pilot Dia. (FAK) (2) _____

4 = 4.500"

Mounting Position (3) _____

H = Horizontal

U = Brake Up

D = Brake Down

Torque (4, 5, 6) _____

0 0 6 = 6 Lb. Ft.

0 0 8 = 8 Lb. Ft.

0 1 2 = 12 Lb. Ft.

Manual Release (7) _____

S = Not Available

Collet Bore (8) _____
(Motor Shaft Dia.)

A = .625"-With Fan

O = .875"- With Fan

V = .625"- Without Fan

Z = .875"- Without Fan

Voltage (9) _____

1 = 115 VAC

2 = 230 VAC

Connector Location (10) _____

B = Front 3-Pin

C = Front 5-Pin (Std.)

Revision (11)
(By Force Control)

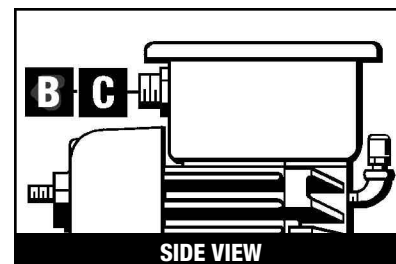

B. MSB4 & MSB6 MagnaShear

01-MSB		5								
1	2	3	4	5	6	7	8	9	10	

Size (1)

4 = MSB4

6 = MSB6

Motor Pilot Dia. (FAK) (2)

5 = No Pilot- Universal Mount - 4-1/2" & 8-1/2"

Mounting Position (3)

H = Horizontal

U = Brake Up

D = Brake Down

Mounting Position (4, 5, 6)

0 1 4 = 14 Lb. Ft.

0 2 1 = 21 Lb. Ft.

0 3 3 = 33 Lb. Ft.

0 3 8 = 38 Lb. Ft.

0 6 2 = 62 Lb. Ft.

0 8 6 = 86 Lb. Ft.

Collet Bore (8)
(Motor Shaft Dia.)

0 = .875"

1 = 1.125"

2 = 1.250"

3 = 1.375"

5 = 1.625"

Manual Release (7)

R = Release

S = None (Std.)

Voltage (9)

1 = 115 VAC / 5-Pin

2 = 230 VAC / 5-Pin

B = 115 VAC / 3-Pin

C = 230 VAC / 3-Pin

Revision (10)
(By Force Control)

REPAIR PARTS LIST
Electric Box and Circuit Board
 (Figure 8.1)

Ref. No.	Part Name	Qty.	Ref. No.	Part Name	Qty.
**398	Conduit Hole Cover	1	*425	Gasket	1
400	Circuit Board	1	426	Button Hd. Screw, #10-24 x 1/4"	1
405	Junction Box	1	428	Pan Hd. Screw, #8-32 x 1/2"	3
410	Indicator Lamp	1	429	Button Hd. Cap Screw, 1/4"-20 x 1/2"	3
415	Electrical Fitting	1	**430	Button Hd. Screw	1
416	Receptacle	1	431	Nylon Washer	3
417	Receptacle Nut	1	432	Lock Washer, 1/4"	3
418	Sealing Ring		435	Stand-Off	3
	MSB2	1			
	MSB4 & MSB6	2			

NOTES:

- * - Indicates parts in Overhaul Kit.
- ** - MSB4 and MSB6 only.

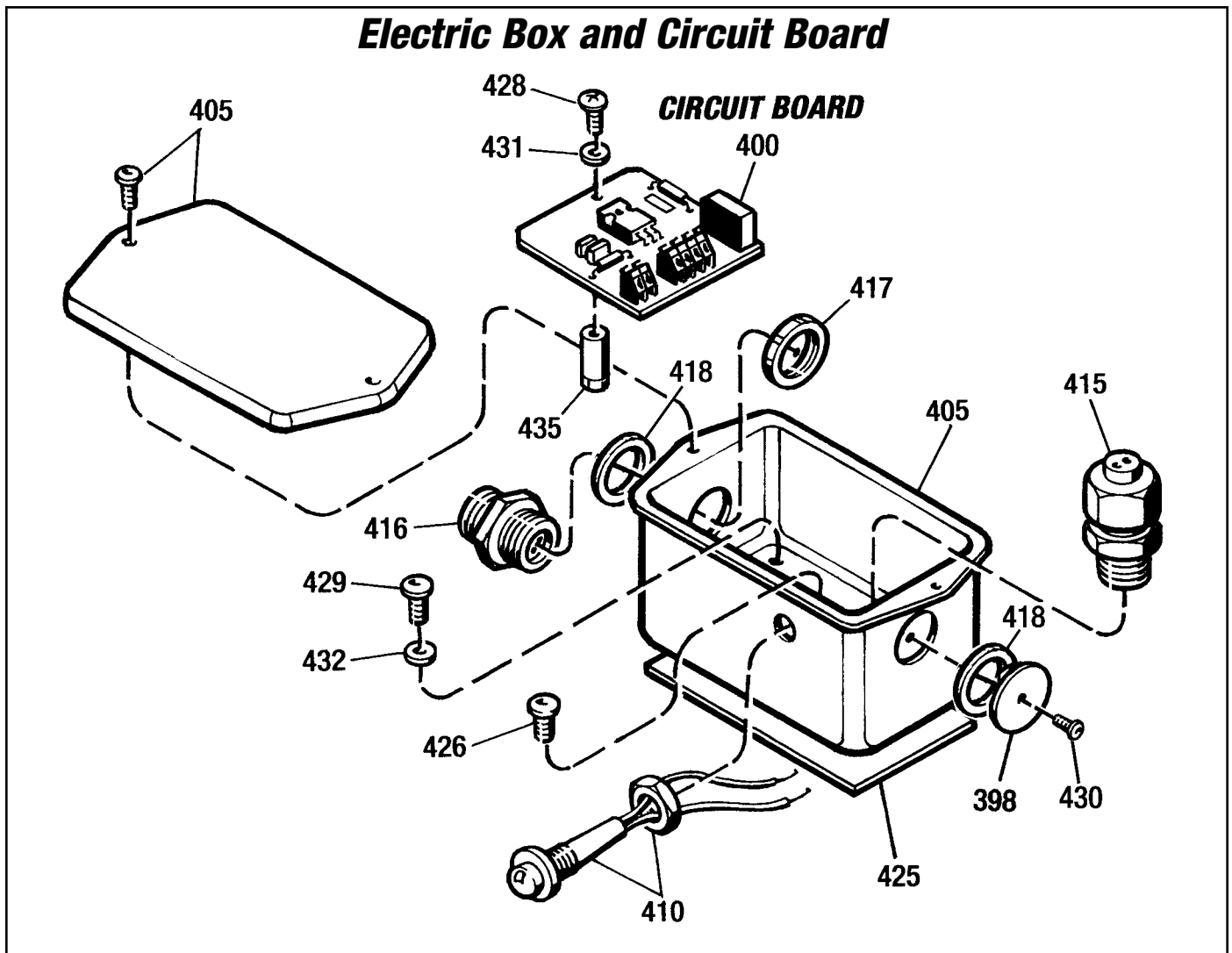

Figure 8.1 - Electric Box and Circuit Board

REPAIR PARTS LIST
MSB2 MagnaShear Motor Brake Sub-Assembly
 (Figure 8.2)

Ref. No.	Part Name	Qty.	Ref. No.	Part Name	Qty.
2	Hub	1	120	Fan.....	1
5	Thrust Plate	1	*121	Gasket	1
9	End Housing	1	127	Lockwasher, 3/8"	4
*12	Drive Plate	5	128	Lockwasher, #10	4
*13	Friction Disc.....	4	129	Lockwasher, 5/16"	4
15	Input Housing	1	144	Shoulder Bolt	2
*17	Separator Springs	8	149	Hex Hd. Cap Screw, 3/8"-16 x 1" Lg.	4
*20	Bearing	1	152	Soc. Hd. Cap Screw, #10-24 x 1/2".	4
*31	Oil Seal	1	153	Low. Hd. Cap Screw, 1/2"-13 x 1-1/4"	1
*36	Spring		168	But. Hd. Cap Screw, #10-24 x 3/8" Lg.	1
	6 Ft. Lbs Torque	3	169	Soc. Hd. Cap Screw, 5/16"-18 x 1" Lg.	4
	8 Ft. Lbs. Torque	4	170	Flat Washer, #10	1
	12 Ft. Lbs. Torque	6	176	Dowel Pin, 3/8" x 1-1/4".....	4
*45	Air Breather	1	179	Pull Dowel w/ Tap, 1/4" x 1" Lg.....	2
*46	Sight Gauge.....	1	181	But. Hd. Screw, #8-32 x 3/8" Lg.	2
55	Shim.....	1	192	But. Hd. Screw, #10-24 x 1/4" Lg.	2
56	Armature Plate.....	1	212	Guard.....	1
58	Armature Ring	1	273	Soc. Hd. Cap Screw, 5/16"-24 x 1" Lg.	2
61	90° Street Elbow, 1/8" NPT	1	274	Washer, Special.....	2
62	Pipe Plug, 1/2" NPT.....	1	275	Lockwasher, 1/2"	1
63	90° Street Elbow, 1/2" NPT	1	284	Coil Assembly	1
64	Pipe Plug, 1/4" NPT.....	1	*986	Shim .005" Blue	AR
*103	O-Ring	1	*987	Shim .010" Brown	AR
112	5/8" Adapter Sleeve (5/8" Quill Only)	1	*988	Shim .020" Yellow	AR
119	Roll Pin	6			

NOTES:

* - Indicates parts in Overhaul Kit.

AR - As Required.

MSB2 "Quick Mount" MagnaShear Motor Brake

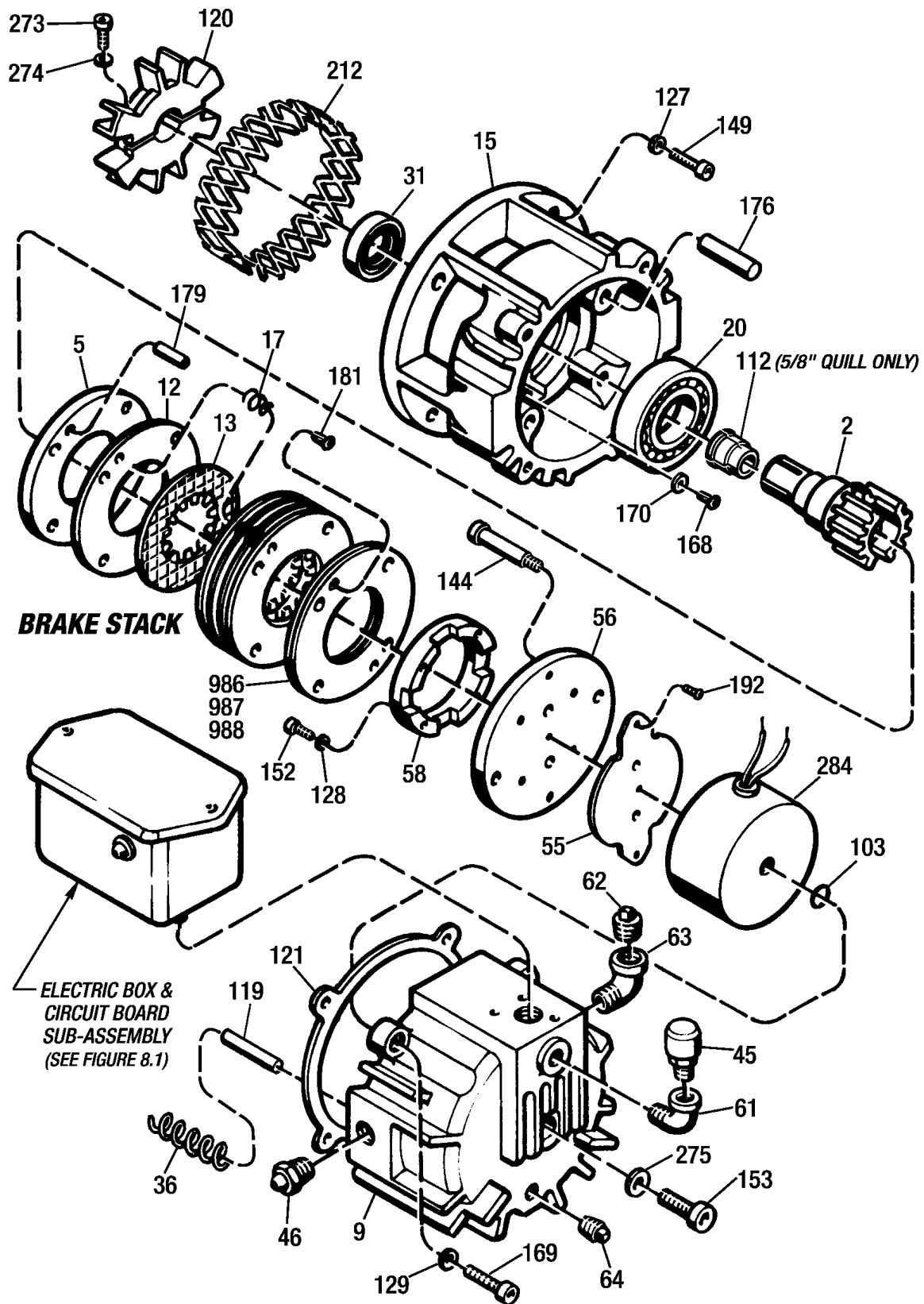

Figure 8.2 - Repair Parts - MSB2 MagnaShear Motor Brake

FORCE CONTROL INDUSTRIES, INC.



MEX (55) 53 63 23 31 MTY (81) 83 54 10 18
 QRO (442) 1 95 72 60 ventas@industrialmagza.com

REPAIR PARTS LIST
MSB4 MagnaShear Motor Brake Sub-Assembly
 (Figure 8.3)

Ref. No.	Part Name	Qty.	Ref. No.	Part Name	Qty.
2	Hub	1	76	Red. Bush., 3/8" x 1/4"	1
5	Thrust Plate	1	99	Expansion Plug	1
9	End Housing	1	*103	O-Ring	1
15	Input Housing	1	108	Roll Pin	1
*20	Bearing	1	111	Locking Collar, 1-1/2" I.D.	1
23	Sleeve, 1-1/8" to 7/8" (Optional)	1	114	Shoulder Bolt	2
*31	Oil Seal	1	*121	Gasket	1
*36	Spring		127	Lockwasher, 5/16"	4
	14 Ft. Lbs Torque	3	128	Lockwasher,	
	21 Ft. Lbs. Torque	4		3/8" (5-7/8" Dia. B.C.)	4
	33 Ft. Lbs. Torque	6		1/2" (7-1/4" Dia. B.C.)	4
*41	Disc Stack Assembly	1	129	Lockwasher, 1/4"	4
*45	Air Breather	1	149	Hex Hd. Cap Screw	
*46	Sight Gauge	1		3/8"-16 x 1-1/4" (5-7/8" Dia. B.C.)	4
49	Pipe Plug, 1/4" NPT	1		1/2"-13 x 1-1/4" (7-1/4" Dia. B.C.)	4
52	Keensert Insert	2	152	Soc. Hd. Cap Screw, #1/4"-20 x 1/2"	4
55	Brass Shim	1	153	Soc. Hd. Cap Screw, 1/2"-13 x 1-3/4"	1
56	Armature Plate	1	168	But. Hd. Cap Screw, #10-24 x 3/8" Lg.	1
58	Armature Ring	1	170	Flat Washer, #10	1
61	90° Street Elbow, 1/2" NPT	1	176	Dowel Pin, 3/8" x 1-3/4"	4
62	Pipe Plug, Sq. Hd., 1/2" NPT	1	177	Roll Pin, 1/4" x 1-1/4"	4
64	Pipe Plug, Mag. Sq. Hd., 1/4" NPT	1	192	But. Hd. Screw, #10-24 x 1/4" Lg.	2
66	90° Street Elbow, 3/8" NPT	1	212	Guard	1
72	Soc. Hd. Cap Screw, 5/16"-18 x 2" Lg.	4	275	Lockwasher, 1/2"	1
73	Pipe Plug, 1/2" NPT	2	284	Coil Assembly	1

NOTES:

* - Indicates parts in Overhaul Kit.

MSB4 "Quick Mount" MagnaShear Motor Brake

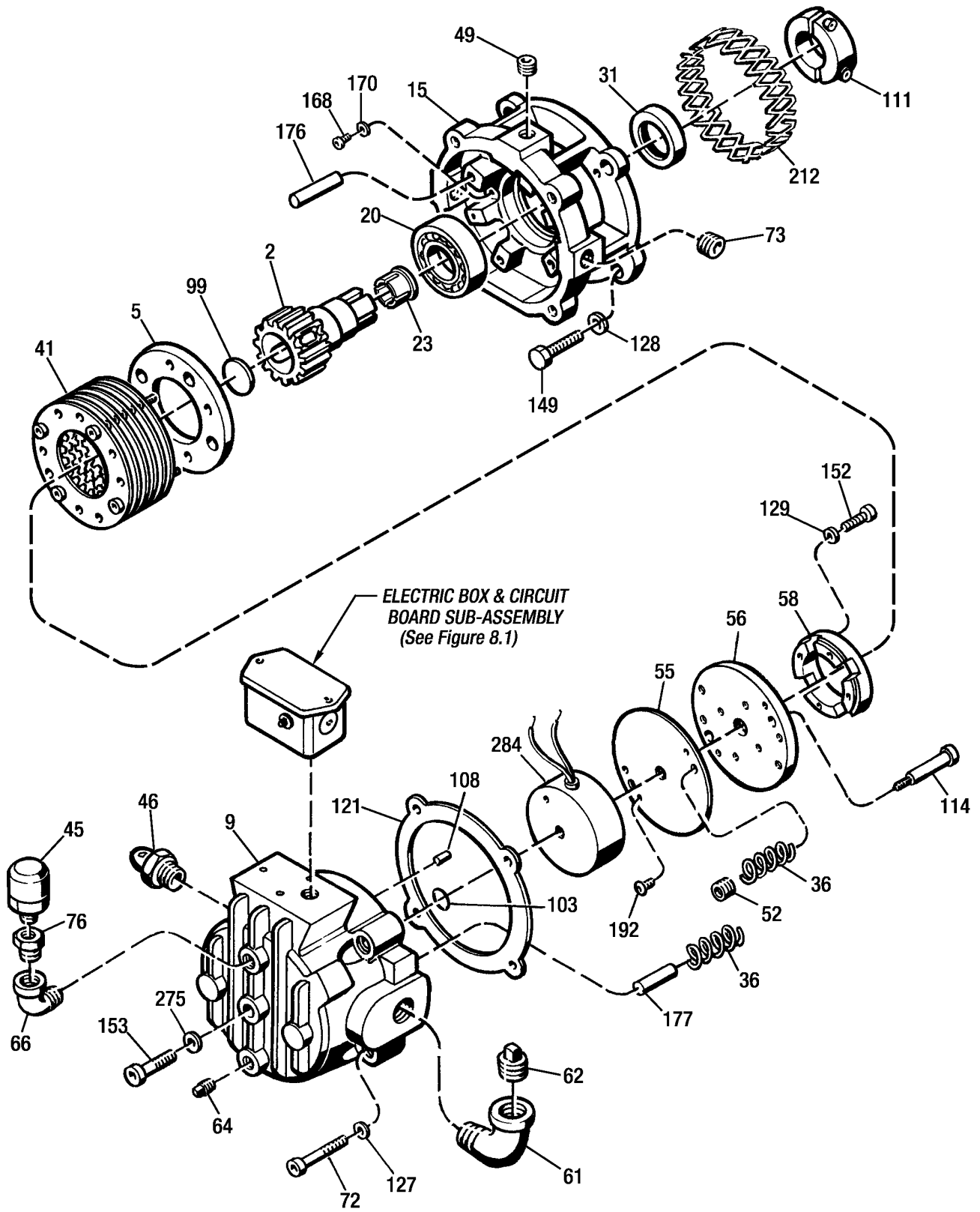

Figure 8.3 - MSB4 "Quick Mount" MagnaShear Motor Brake

FORCE CONTROL INDUSTRIES, INC.



MEX (55) 53 63 23 31 MTY (81) 83 54 10 18
 QRO (442) 1 95 72 60 ventas@industrialmagza.com

REPAIR PARTS LIST
MSB6 MagnaShear Motor Brake Sub-Assembly
(Figure 8.4)

Ref. No.	Part Name	Qty.	Ref. No.	Part Name	Qty.
2	Hub	1	72	Soc. Hd. Cap Screw, 3/8"-16 x 1-1/4" Lg.	8
5	Thrust Plate	1	73	Pipe Plug, 1/2" NPT	2
9	End Housing	1	99	Expansion Plug	1
15	Input Housing	1	111	Locking Collar	1
*20	Bearing	1	*122	Gasket	1
23	Sleeve, 1-3/8" to 1-1/8" (Optional).....	1	127	Lockwasher, 3/8"	8
*31	Oil Seal	1	128	Lockwasher, 5/8"	1
*36	Spring		129	Lockwasher, 1/4"	4
	38 Ft. Lbs. Torque	4	*130	O-Ring	1
	62 Ft. Lbs. Torque	6	138	Shoulder Bolt	4
	86 Ft. Lbs. Torque	8	152	Soc. Hd. Cap Screw, #1/4"-20 x 3/4"	4
*41	Disc Stack Assembly	1	153	Soc. Hd. Cap Screw, 5/8"-11 x 1-1/2"	1
*45	Air Breather	1	166	Hex Hd. Screw, 1/2"-13 x 1-1/4" Lg.	4
*46	Sight Gauge	1	167	Lockwasher, 1/2"	4
49	Pipe Plug, 1/8" NPT	3	168	But. Hd. Cap Screw, #10-24 x 3/8" Lg.	1
52	Keensert Insert	2	170	Flat Washer, #10	1
55	Brass Shim	1	176	Dowel Pin, 3/8" x 2"	4
56	Armature Plate.....	1	177	Roll Pin, 1/4" x 1-1/4".....	4
58	Armature Ring	1	178	Roll Pin	1
61	90° Street Elbow, 1/2" NPT	1	192	But. Hd. Screw, #10-24 x 1/4" Lg.	2
62	Pipe Plug, Sq. Hd., 1/2" NPT	1	212	Guard.....	1
64	Pipe Plug, Mag. Sq. Hd., 1/4" NPT	1	284	Coil Assembly	1

NOTES:

* - Indicates parts in Overhaul Kit.

MSB6 "Quick Mount" MagnaShear Motor Brake

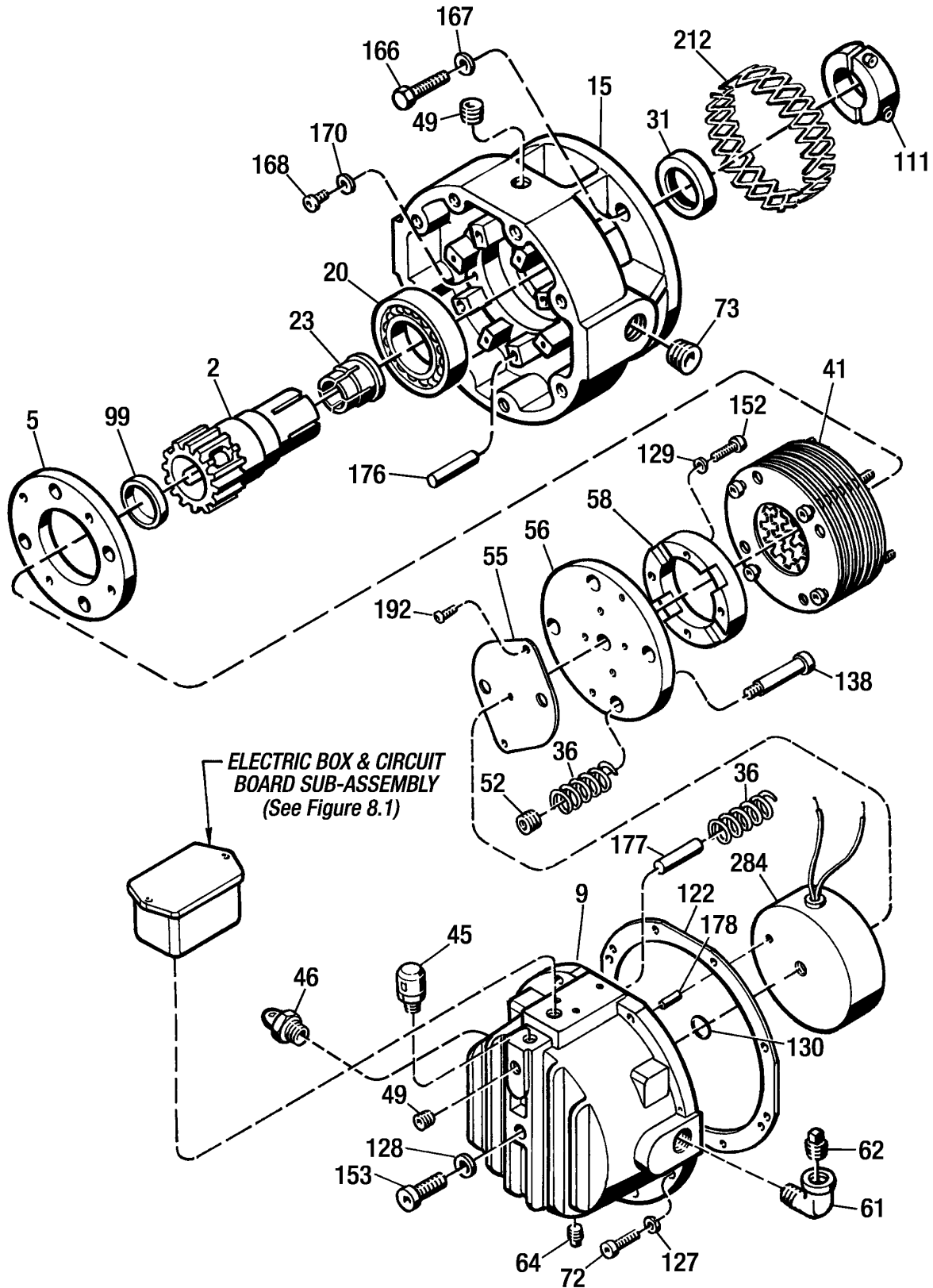

Figure 8.4 - MSB6 "Quick Mount" MagnaShear Motor Brake

FORCE CONTROL INDUSTRIES, INC.



MEX (55) 53 63 23 31 MTY (81) 83 54 10 18
 QRO (442) 1 95 72 60 ventas@industrialmagza.com

REPAIR PARTS LIST

MSB2 MagnaShear Motor Brake - Vertical Installation

(Figure 8.5)

VERTICAL UP

Ref. No.	Part Name	Qty.
*45	Air Breather	1
*46	Sight Gauge	1
62	Pipe Plug, 1/2" NPT Sq. Hd.	1
63	Street Elbow, 1/2" NPT	1
64	Pipe Plug, 1/4" NPT Mag. Sq. Hd.	1
71	Pipe Nipple, 1/4" NPT	1
73	Pipe Plug, 1/4" NPT C'Sunk	2
74	Pipe Plug, 1/8" NPT C'Sunk	1
75	Pipe Plug, 1/2" NPT C'Sunk	2
140	Female Elbow, 1/4" NPT	1

VERTICAL DOWN

Ref. No.	Part Name	Qty.
*45	Air Breather	1
*46	Sight Gauge	1
62	Pipe Plug, 1/2" NPT Sq. Hd.	1
63	Street Elbow, 1/2" NPT	1
64	Pipe Plug, 1/4" NPT Mag. Sq. Hd.	1
69	Pipe Nipple, 1/8" NPT	1
73	Pipe Plug, 1/4" NPT C'Sunk	2
74	Pipe Plug, 1/8" NPT C'Sunk	1
75	Pipe Plug, 1/2" NPT C'Sunk	2
125	Female Elbow, 1/8" NPT	1

NOTES:

* - Indicates parts in Overhaul Kit.

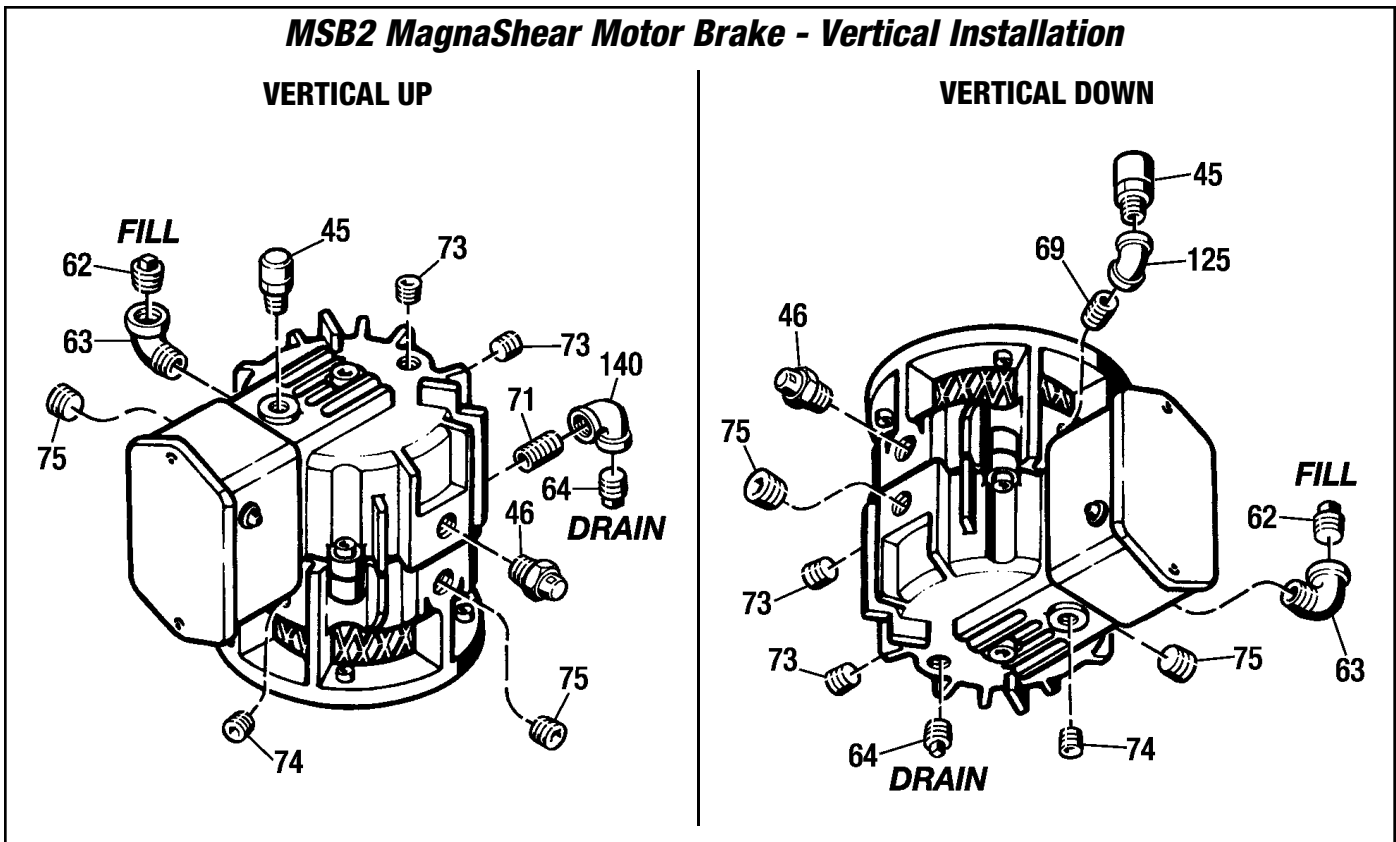

Figure 8.5 - MSB2 MagnaShear Motor Brake - Vertical Installation

REPAIR PARTS LIST

MSB4 MagnaShear Motor Brake - Vertical Installation

(Figure 8.6)

VERTICAL UP

Ref. No.	Part Name	Qty.
*45	Air Breather	1
*46	Sight Gauge	1
64	Pipe Plug, 1/4" NPT Mag. Sq. Hd.	1
73	Pipe Plug, 1/2" NPT C'Sunk	3
76	Reducer Bushing, 3/8" x 1/4" NPT	1
131	Pipe Plug, 1/4" NPT Sq. Hd.	1

VERTICAL DOWN

Ref. No.	Part Name	Qty.
*45	Air Breather	1
*46	Sight Gauge	1
61	Street Elbow, 1/2" NPT	1
62	Pipe Plug, 1/2" NPT, Sq. Hd.	1
64	Pipe Plug, 1/4" NPT Mag. Sq. Hd.	1
66	Street Elbow, 1/4" NPT	1
73	Pipe Plug, 1/2" NPT C'Sunk	2
75	Pipe Plug, 3/8" NPT C'Sunk	1

NOTES:

* - Indicates parts in Overhaul Kit.

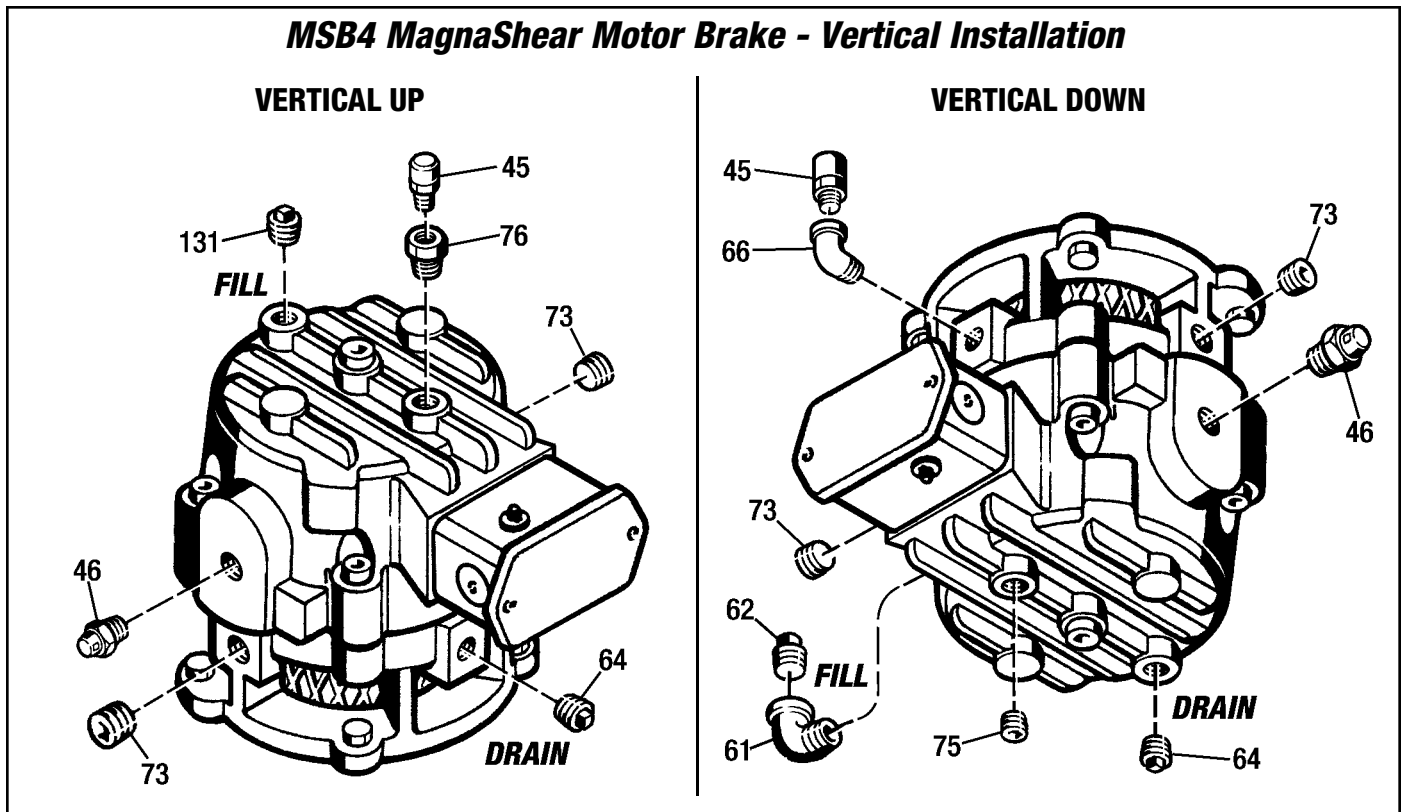

Figure 8.6 - MSB4 MagnaShear Motor Brake - Vertical Installation

REPAIR PARTS LIST
MSB6 MagnaShear Motor Brake - Vertical Installation
 (Figure 8.7)

VERTICAL UP

Ref. No.	Part Name	Qty.
*45	Air Breather	1
*46	Sight Gauge	1
49	Pipe Plug, 1/8" NPT C'Sunk	2
50	Pipe Plug, 1/4" NPT C'Sunk	1
62	Pipe Plug, 1/2" NPT Sq. Hd.	2
63	Street Elbow, 1/2" NPT	1
64	Pipe Plug, 1/2" NPT Mag. Sq. Hd.	1
73	Pipe Plug, 1/2" NPT C'Sunk	1

NOTES:

* - Indicates parts in Overhaul Kit,

VERTICAL DOWN

Ref. No.	Part Name	Qty.
*45	Air Breather	1
*46	Sight Gauge	1
49	Pipe Plug, 1/8" NPT C'Sunk	1
50	Pipe Plug, 1/4" NPT C'Sunk	1
62	Pipe Plug, 1/2" NPT Sq. Hd.	1
63	Street Elbow, 1/2" NPT	1
64	Pipe Plug, 1/4" NPT Mag. Sq. Hd.	1
66	Street Elbow, 3/8" NPT	1
73	Pipe Plug, 1/2" NPT C'Sunk	2

NOTES:

* - Indicates parts in Overhaul Kit,

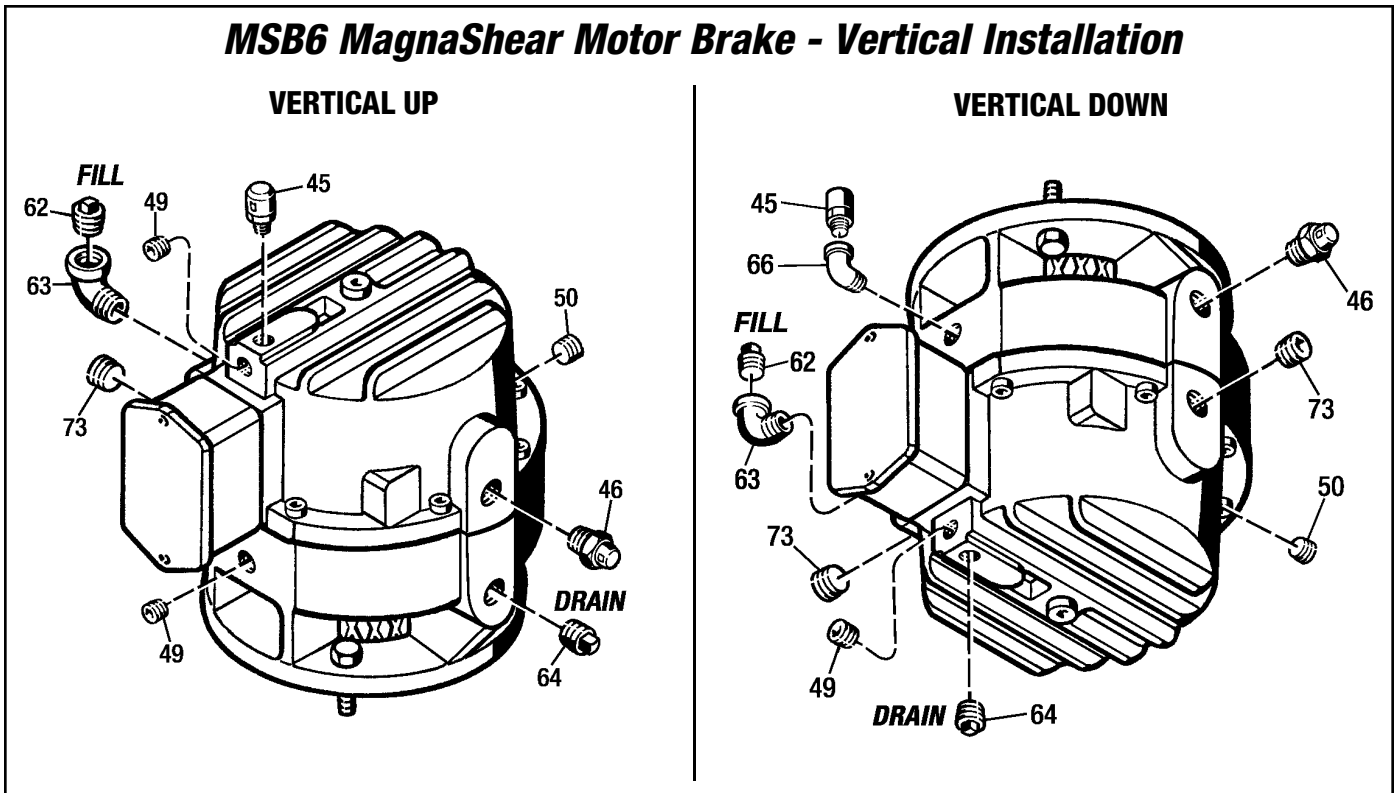

Figure 8.7 - MSB6 MagnaShear Motor Brake - Vertical Installation

Manual Revision & Printing History

MSB2, MSB4 & MSB6 “Quick Mount” MagnaShear Motor Brake

REVISION NUMBER	REVISION DATE <i>(Mo./Yr.)</i>	PRINTING DATE <i>(Mo./Yr.)</i>	REVISION/ACTION DESCRIPTION	REVISION INITIATED BY: <i>(Name)</i>	REVISION MADE BY: <i>(Name)</i>
502-MSB2-6-003-00	4/04	-----	<ul style="list-style-type: none"> • Added MSB4 and MSB6 “Quick Mount” to the existing MSB2 Manual to create this new manual. 	Tim Vonderhaar	Jerry Brooks

FORCE CONTROL INDUSTRIES, INC.

Worldwide Leader in "Oil Shear" Product Design

*Providing Today's Industries with:
Oil Shear Clutch/Brake Drives
and Electronic Drive Systems
That Delivers:
Flexibility • Efficiency
Endurance • Performance
Dependability*

"Built to Last - Guaranteed to Perform"



FORCE CONTROL INDUSTRIES, INC.

MAIN OFFICE

P.O. Box 18366
Fairfield, Ohio 45018

3660 Dixie Highway
Fairfield, Ohio 45014

Tel: (513) 868-0900
Fax: (513) 868-2105

E-Mail: info@forcecontrol.com

Web: www.forcecontrol.com



DIST. AUTORIZADO

MEX (55) 53 63 23 31
QRO (442) 1 95 72 60

MTY (81) 83 54 10 18
ventas@industrialmagza.com