

4000 Series Analyser

Installation Manual

Ref:04000/005C/6
Order as part 04000 005C

The configuration of this analyser is																	
Model and Issue: 04 _____ C1																	
Feature and option code number																	
F1	F2	F3	F4	F5	F6	F7	F8	F9	F10	F11	F12	F13	F14	F15	F16	F17	F18
--	--	-	-	-	-	-	-	-	-	-	-	-	-	-	-	-	-
Serial number _ _ _ _ _																	

Instrument Configuration

Transducer I1 Type: Serial No: Sample Inlet Position 1	Transducer I2 Type: Serial No: Sample Inlet Position
Transducer I3 Type: Serial No: Sample Inlet Position	Transducer I4 Type: Serial No: Sample Inlet Position
Servomex Order Reference No:	
Software Revision No:	
Completed By:	Date :

WARNINGS, CAUTIONS AND NOTES

This publication includes **WARNINGS, CAUTIONS AND NOTES** which provide information relating to the following:

WARNINGS : Hazards which could result in personal injury or death.

CAUTIONS : Hazards which could result in equipment or property damage.

NOTES : Alert the user to pertinent facts and conditions.

NOTE

This manual covers installation, routine maintenance and fault diagnosis on all the 4000 series 'C' models.

The following symbols are used on the rear of the analyser:



Earth (ground) terminal



Caution, refer to operator manual

List of Contents

SECTION 1	INTRODUCTION	1.1
1.1	Introduction	1.1
1.2	General description	1.1
1.3	Location of components	1.3
1.4	Transducer site numbering system	1.4
1.5	Output numbering system	1.4
1.6	Transducer full scale deflection	1.4
1.7	Conversion of transducer measuring units	1.5
1.8	Calibration - General	1.7
1.9	Automatic calibration options	1.7
SECTION 2	INSTALLATION - GENERAL	2.1
2.1	Introduction	2.1
2.2	Unpacking and inspection	2.2
2.3	Bench mount installation	2.3
2.4	Panel mount installation	2.3
2.5	Rack slide mounting installation	2.4
SECTION 3	INSTALLATION - ELECTRICAL	3.1
3.1	Electrical power connection	3.1
3.2	Signal connections	3.2
3.2.1	mA output and relay output connections	3.4
3.2.2	Analogue inputs	3.6
3.2.3	External autocalibration connection	3.7
3.3	Serial data/Modbus connection	3.8
3.4	Continuous mode	3.9
3.5	Modbus mode	3.10
3.6	EMC Installation	3.11
SECTION 4	INSTALLATION – GAS CONNECTIONS	4.1
4.1	Introduction	4.1
4.2	Calibration gases	4.1
4.2.1	Gfx transducer low and high calibration	4.2
4.2.2	IR transducer low and high calibration	4.2
4.2.3	Paramagnetic transducer low and high calibration	4.2
4.2.4	Zirconia transducer low and high calibration	4.3
4.3	Gas connections	4.3
4.4	Reading flowmeters	4.5
4.5	Autocalibration overview	4.5
4.6	Autocalibration valve installation	4.7
4.7	Power up	4.10
SECTION 5	ROUTINE MAINTENANCE	5.1
5.1	Replacing fan filter element	5.1
5.2	Replacing the sample filter element	5.1
5.3	Cleaning	5.2
5.4	Toxic/flammable samples - routine leak test	5.2

SECTION 6	SPARES	6.1
SECTION 7	TECHNICAL SPECIFICATIONS	7.1
7.1	Introduction	7.1
7.2	Generic 4000 series analyser performance	7.1
7.2.1	Environmental specifications	7.1
7.2.2	Power supply	7.1
7.2.3	Design standards	7.1
7.2.4	Analogue outputs	7.2
7.2.5	Alarms	7.2
7.2.6	Serial data/Modbus connection	7.2
7.2.7	Analogue inputs	7.2
7.2.8	Digital inputs	7.2
7.2.9	Sample wetted materials	7.3
7.3	4100C analyser performance	7.5
7.4	4200C analyser performance	7.9
7.5	4210C analyser performance	7.12
7.6	4900C analyser performance	7.15
APPENDIX A	EFFECTS OF VARIATIONS IN SAMPLE COMPOSITION	A.1
APPENDIX B	MODBUS PROFILE	B.1

List of Figures

Figure 1.1:	Key features of 4000 series analyser	1.3
Figure 2.1:	Panel mounting detail.	2.3
Figure 2.2:	Rack installation exploded view	2.4
Figure 3.1:	Position of F2 in voltage selector for 170V to 264V operation	3.2
Figure 3.2:	Position of F2 in voltage selector for 85V to 132V operation	3.2
Figure 3.3:	Signal socket assembly	3.3
Figure 4.1:	Sample gland plate without autocalibration	4.3
Figure 4.2:	Sample gland plate with internal autocalibration	4.3
Figure 4.3:	External autocalibration - parallel systems	4.8
Figure 4.4:	External autocalibration - stream systems	4.9

List of Tables

Table 1.1:	Transducer FSD values and availability in product range	1.6
Table 1.2:	Recommended calibration periods	1.7
Table 3.1:	Signal terminal location PL1 to PL4	3.5
Table 3.2:	Optional external autocalibration connections PL8	3.5
Table 3.3:	Signal terminal location PL5	3.7
Table 3.4:	External autocalibration truth table	3.8
Table 3.5:	Serial output connections PL6	3.8
Table 3.6:	Serial output data frame, start and end sequences	3.9
Table 3.7:	Serial output data frame, measurement sequences	3.10
Table 4.1:	4900C calibration gas examples	4.2
Table 4.2:	4100C and 4200C sample port vs transducer type	4.4
Table 4.3:	4210C sample port type	4.4
Table 4.4:	4900C sample port type	4.5
Table 7.1:	Sample wetted materials	7.3
Table 7.2:	Sample wetted materials, continued	7.4
Table 7.3:	4100C performance specification, oxygen	7.6
Table 7.4:	4100C performance specification, Gfx	7.7
Table 7.5:	Gfx trace measurement cross sensitivity information	7.7
Table 7.6:	4100C performance specification, IR	7.8
Table 7.7:	152X measurement ranges in 4100C	7.8
Table 7.8:	4200C performance specification, oxygen and IR	7.10
Table 7.9:	152X measurement ranges in 4200C	7.10
Table 7.10:	4200C performance specification, Gfx	7.11
Table 7.11:	Gfx trace measurement cross sensitivity information	7.11
Table 7.12:	4210C performance specification, oxygen and IR	7.13
Table 7.13:	152X measurement ranges in 4210C	7.13
Table 7.14:	4210C performance specification, Gfx	7.14
Table 7.15:	Gfx trace measurement cross sensitivity information	7.14
Table 7.16:	4900C performance specification, oxygen and IR	7.16
Table 7.17:	152X measurement ranges in 4900C	7.16
Table 7.18A:	4900C performance specification, Gfx	7.17
Table 7.19A:	4900C measurement cross sensitivity information	7.17
Table 7.18B:	4900C performance specification, Gfx	7.18
Table 7.19B:	4900C measurement cross sensitivity information	7.18

SECTION 1 INTRODUCTION

1.1 Introduction

This manual contains information regarding installation and hardware configuration of the Servomex 4000 series analysers.

A separate Quickstart manual is also supplied with the analyser, reference part number 04000/003C. This details software configuration and operation of the analyser. Extra copies may be ordered from Servomex.

Details of the hardware and instructions for servicing, by qualified personnel only, are presented in the 4000 Series Service Manual. This may be ordered from Servomex using part number 4000002C.

Technical assistance and spare parts are available from Servomex outlets (or their local agents) listed on the back cover.

WARNING

The analyser contains no user serviceable parts inside. The instrument enclosure protects the user from electric shock and other hazards. All servicing should be referred to qualified personnel.

Modbus™ is a trademark of AEG-MODICON.

1.2 General description

The Servomex 4000 series analyser is a chassis into which up to four gas sensor modules may be fitted. The chassis provides power, gas connections and other support functions to the sensors and calculates associated sample gas concentrations. These concentrations are then displayed on the analyser display screen and may be directed to the analogue outputs and/or the serial output.

The analyser also supports two external analogue input signals. The data from the external inputs may be displayed on the screen, output to the analogue outputs and/or the serial output or accessed using Modbus.

Designed for use in modern industrial and laboratory environments, the analyser is controlled using an integral microprocessor which provides significant user flexibility.

The 4100 analyser is designed to meet the control and product quality monitoring requirements of industrial gas producers and users. It can monitor up to four gas streams simultaneously with independent autocalibration for each stream (provided sufficient extra relays are installed).

The 4200 analyser is intended for monitoring flammable samples, but not those containing hydrogen or acetylene for which the 4210 must be used. Again, up to four gas streams may be monitored simultaneously and independent autocalibration can be used with each stream. The zirconia transducer is not available for these analysers.

The 4900 analyser is a continuous emissions monitoring (CEMs) analyser with a maximum of four transducers with either one or two sample streams. Independent autocalibration is available for each stream or transducer (refer to Section 4.6).

None of the above are suitable for use with corrosive samples.

A number of optional features are available for the 4000 series. These may include the following, depending upon analyser configuration:

- Flow meters and needle valves (on the 4900C only) to monitor and control sample gas flow through the instrument.
- A sample filter to protect the gas sensor modules from particulate contamination.
- A sample flow alarm to monitor the sample flow and alarm when the flow falls below a defined level. This is only available on 4100C (Gfx flow driven) and 4900C product.
- An autocalibration manifold (for a single sample stream) to allow the instrument to be calibrated without user intervention. On the 4100C this is only suitable for paramagnetic transducers.
- Additional relay output contacts to allow autocalibration of the analyser via externally located valves.
- Additional signal output cards to extend the number of analogue outputs and relay outputs available to the user.

(Full technical specifications for 4000 series is presented at the back of this manual).

Start up and commissioning of the analyser should be performed as follows:

Use this manual for:

Installation	To take commissioning to the point where the analyser is powered and operational. The installer is advised to read this manual completely before commencing installation.
---------------------	---

Use the Quickstart manual for:

Configuration	How to set up the clock, passwords, alarm levels, analogue outputs, relays and other parameters.
----------------------	--

Calibration	How to use the manual and automatic calibration/checking facilities.
--------------------	--

Review	How to display analogue output settings, relay allocation, alarms, faults and analyser identity without changing the analyser settings.
---------------	---

1.3 Location of components

Figure 1.1 identifies the location of the key features of the analyser. Note that the identification label (including serial number information) is located on the underside of the unit towards the rear.

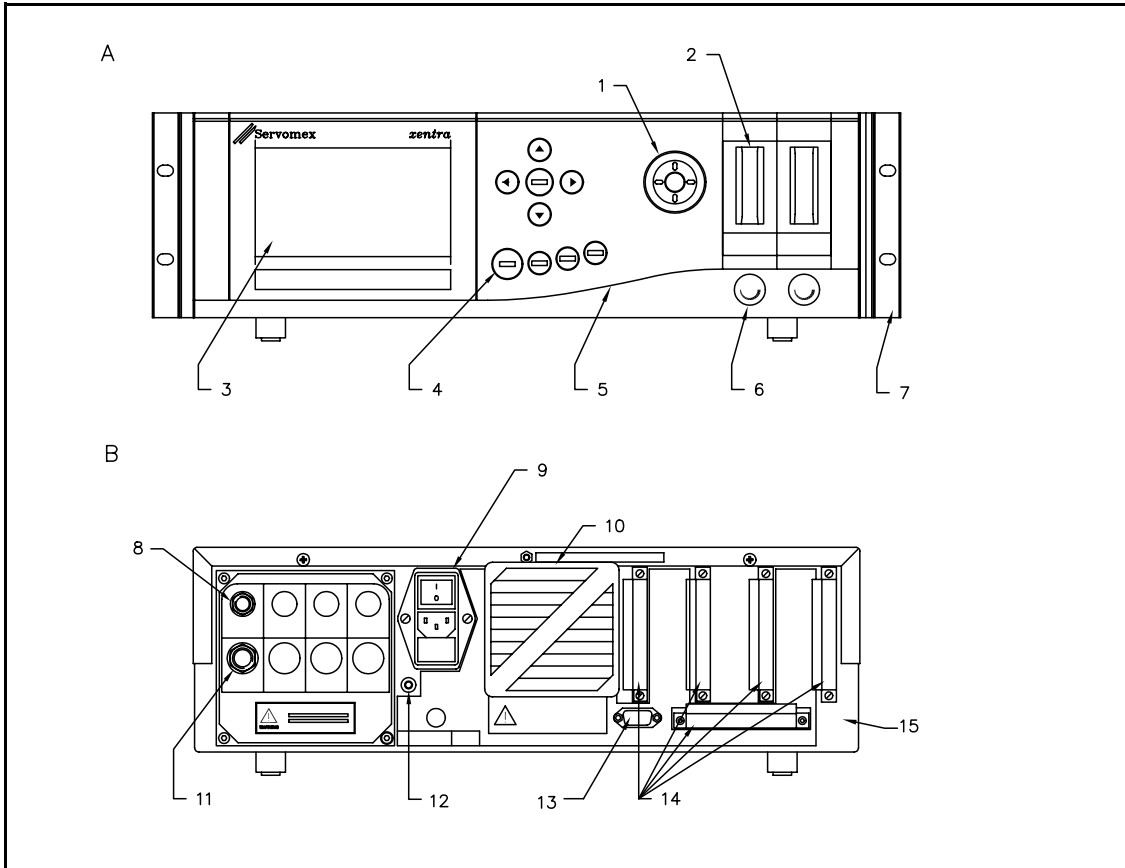

Figure 1.1: Key features of 4000 series analyser

Key	A	FRONT VIEW	8	Sample inlet(s)
	B	REAR VIEW	9	Mains power connector
	1	Sample filter (optional)	10	Fan and filter
	2	Flowmeter(s) (optional)	11	Sample outlet(s)
	3	Display	12	Functional earth
	4	Keypad	13	Serial output/Modbus port
	5	Display adjustment	14	Signal terminals
	6	Needle valve(s) (optional)	15	Screen
	7	Rack mounting brackets		

1.4 Transducer site numbering system

The four internal transducers are assigned site locations represented as I1, I2, I3 and I4 on the display.

In the case of the 4100 and the 4200 analysers, each transducer is served by a discrete sample inlet and outlet connection on the rear panel.

In the case of the 4900 analyser, either one or two sample streams may be specified - consequently only inlets/outlets numbered 1 and 2 will be used.

1.5 Output numbering system

Identification numbers appear on the rear label to identify the terminals where each output appears and on the display when the outputs are being configured. These have a two digit identification number of the following format : Card number. Output No.

e.g.. the outputs fitted as standard on the SIB pcb in card position 1 are:

- 1.1 Analogue output
- 1.2 Analogue output
- 1.3 Relay
- 1.4 Relay
- 1.5 Relay

1.6 Transducer full scale deflection

The transducer full scale deflection (FSD) is the maximum concentration level that may be measured and displayed with the precision and accuracy specified for that transducer. This may also be termed the measurement range for the transducer. Concentration levels that exceed 120% of the FSD are considered as over range and are indicated by the word 'OVER' on the analyser display.

There are two set up parameters on the analyser that are expressed in terms of the FSD:

- Calibration tolerances for the transducers.
- Alarm hysteresis.

When defining minimum output ranges, the relevant transducer noise specification should be considered; refer to Section 7. (Table 1.1 lists all available transducer types and FSD values).

NOTE

The following abbreviations are used throughout this manual:

Gfx	Gas filter correlation infra-red transducer
IR	Pulsed infra-red transducer
Pm	Paramagnetic transducer
Zr	Zirconia transducer

1.7 Conversion of transducer measuring units

As supplied, the standard transducers within the analyser will measure in the units indicated in Table 1.1. It is possible to change these units by the use of a linear scale factor (refer to Quickstart manual). The user should note that the **4000 series software prime measurement is in percentage**, therefore trace level 'vpm' (volume parts per million) measurements already have a scale factor of 10,000 entered as a default.

Example: to convert vpm SO₂ to mg/m³, a multiplier of 2.86 is used. As the software actually converts from percentage levels, the overall scale factor entered as part of the analyser configuration will be 28600.

Table 1.1: Transducer FSD values and availability in product range:				
Transducer	FSD	4100	4200 4210	4900
Gfx1210 CO Standard sensitivity	3000vpm CO	-	-	✓
Gfx1210 CO High sensitivity	500vpm CO	✓	✓	✓
Gfx 1210 SO ₂ Standard sensitivity	2500vpm SO ₂	-	-	✓
Gfx 1210 SO ₂ High sensitivity	1000vpm SO ₂	-	-	✓
Gfx 1210 NO High sensitivity	1000vpm NO	-	-	✓
Gfx1210 CO ₂ High sensitivity	100vpm CO ₂	✓	✓	-
Gfx 1210 CH ₄ High sensitivity	500vpm CH ₄	✓	✓	✓
Gfx 1210 N ₂ O High sensitivity	500vpm N ₂ O	✓	✓	✓
IR 1520 100% CO ₂	100% CO ₂	✓	✓	✓
IR 1520 50% CO ₂	50% CO ₂	✓	✓	✓
IR 1520 25% CO ₂	25% CO ₂	✓	✓	✓
IR 1520 10% CO ₂	10% CO ₂	✓	✓	✓
IR 1520 5% CO ₂	5% CO ₂	✓	✓	✓
IR 1520 2.5% CO ₂	2.5% CO ₂	✓	✓	✓
IR 1520 1% CO ₂	1% CO ₂	✓	✓	✓
IR 1520 0.5% CO ₂	0.5% CO ₂	✓	✓	✓
IR 1520 0.25% CO ₂	0.25% CO ₂	✓	✓	✓
IR 1521 100% CH ₄	100% CH ₄	-	✓	-
IR 1521 50% CH ₄	50% CH ₄	-	✓	-
IR 1521 25% CH ₄	25% CH ₄	-	✓	-
IR 1521 5% CH ₄	5% CH ₄	-	✓	-
IR 1522 50% CO	50% CO	-	✓	-
IR 1522 25% CO	25% CO	-	✓	-
IR 1522 10% CO	10% CO	✓	✓	✓
IR 1522 2.5% CO	2.5% CO	✓	✓	✓
IR 1522 1% CO	1% CO	✓	✓	✓
Pm 1158 O ₂ Control	100% O ₂	✓	✓	✓
Pm 1111 O ₂ Basic	100% O ₂	✓	-	✓
Pm Purity O ₂ (04100995A)	100% O ₂	✓	-	-
Zirconia 704 O ₂ Trace plus indicative reading above 21% O ₂	210000vpm O ₂	✓	-	-

1.8 Calibration - General

For optimum performance, it will be necessary to routinely check the calibration of all of the internal gas sensors within the analyser. The recommended periods for each sensor type are shown in Table 1.2.

Table 1.2: Recommended calibration periods		
Gas sensor module	Low calibration	High calibration
Gfx sensor	weekly	monthly
IR sensor	weekly	daily
Paramagnetic sensor (purity)	monthly	weekly
Paramagnetic sensor (other)	weekly	weekly
Zirconia sensor	monthly	monthly

In addition, the pressure compensation associated with the purity paramagnetic sensor should be checked annually (the procedure is covered in the Quickstart manual).

The calibration procedure is dealt with in the Quickstart manual. However, this manual details the requirements for and configuration of calibration ancillaries (such as gases) and (when autocalibration is used) the connection of solenoid valves, the potential use of the RS232 output and remote initiation switch and the use of Modbus to initiate calibration.

(When the optional external autocalibration or the optional internal autocalibration manifold are configured and fitted, a manual calibration adjustment or calibration check will use the autocalibration valves to select the calibration sample gases as required).

1.9 Automatic calibration options

All 4000 series analysers include the software necessary to provide automatic calibrations.

In the case of 'external' autocalibration, external (i.e.: customer supplied) solenoid valves may be controlled by interrogating the serial output signal or by discrete wiring to relays on the analyser (ensure that sufficient optional output cards have been installed).

The automatic calibration procedure may be started by any of the following:

- A user keyboard input
- A trigger from the internal instrument clock
- An external contact closure
- A Modbus command

NOTES

SECTION 2 INSTALLATION - GENERAL

2.1 Introduction

NOTE

Sections 2, 3 and 4 provide all the information required to install any 4000 series analyser. The installer is advised to read all sections completely before commencing installation.

Installation will only require the use of standard hand tools.

The analyser is suitable for indoor use and may be configured for either bench mount, panel mount or 19" rack mount.

CE MARKING

The 4000 series analysers carry the CE mark which indicates conformity with the European Directives on CE Marking (93/68/EEC), Electromagnetic Compatibility (EMC 89/336/EEC) and Low Voltage Directive (LVD 73/23/EEC).

The analyser is rated in accordance with IEC 664 for:

'POLLUTION DEGREE 2' where normally only non-conductive pollution occurs.

'INSTALLATION CATEGORY II', which is characterised as being local level (i.e. not distribution level), appliances and portable equipment with over-voltage impulse withstand up to 2500 Volts.

Ambient operating conditions

Parameter	Model	Range
Operating temperature	4100, 4200, 4210	+5°C to +40°C (+41°F to 104°F)
	4900	+5°C to +45°C (+41°F to 113°F)
Storage temperature	All	-20°C to +60°C (-4°F to +140°F)
Atmospheric pressure	All	79 to 124kPaa (11 to 18psia) (for operating altitudes up to 2000m)

Select a location which allows convenient access for installation and maintenance and will minimise ambient temperature fluctuations and vibration.

WARNING

- **The 4000 series analyser is not suitable for use in hazardous areas.**
- **The analyser is not suitable for use with corrosive samples.**
- **Gases may be toxic or asphyxiant and must be vented to a safe location. (In the case of the 4200 and 4210 models, gases may also be flammable)**

CAUTION

Install the analyser so that fan and cover vents are not obstructed.

2.2 Unpacking and inspection

WARNING

The 4000 series analysers weigh up to 22kg (45lb) and care must be taken when handling. It is recommended that they are lifted with hands positioned on either side of the base of the chassis.

The rack mounting brackets (see Figure 2.1 Item 1) are not designed to be used as handles or grips. When removing the instrument from its packing, and for subsequent handling, ensure that the analyser is gripped securely underneath. Lift and remove the analyser from its packing and inspect for any damage incurred during transit. If damage has occurred, inform Servomex or its agent immediately. Retain all packing and shipping information. The shipping carton may be used for future transportation.

After the initial visual inspection, perform the following checks:

- 1 Check that the specification details table in the front of this manual agree with the purchase requirements. Pay particular attention to any inserted instrument modification sheets.
2. Check that the accessories are present and undamaged.

Standard accessories provided are:

- Spare mains fuses suitable for electrical power voltage range ordered.
- Two connectors for wiring to standard chassis signal output plugs (PL1 and PL5).
- Electrical power cord with moulded IEC connector or loose IEC connector for wiring during installation.

Optional accessories are:

- Connectors for wiring to each optional signal output plug (PL2 to PL4).
- Spanner and spare filter elements (for those analysers configured with a sample filter).
- Rack mounting slides and kit of parts (See Figure 2.2).

2.3 Bench mount installation

The analyser should be mounted on a sturdy, level surface. The bench mount version has four feet. If the front two are flipped down, the floats in the optional flowmeters may not rotate, however, the flow indication will still be correct.

2.4 Panel mount installation

See Figure 2.1 for panel mounting detail. In panel mounting format the analyser is supplied with a pair of mounting brackets (item 1) suitable for mounting the front of the instrument against a panel.

WARNING

The rack mounting brackets are not intended to provide the sole means of support. The user must provide additional support.

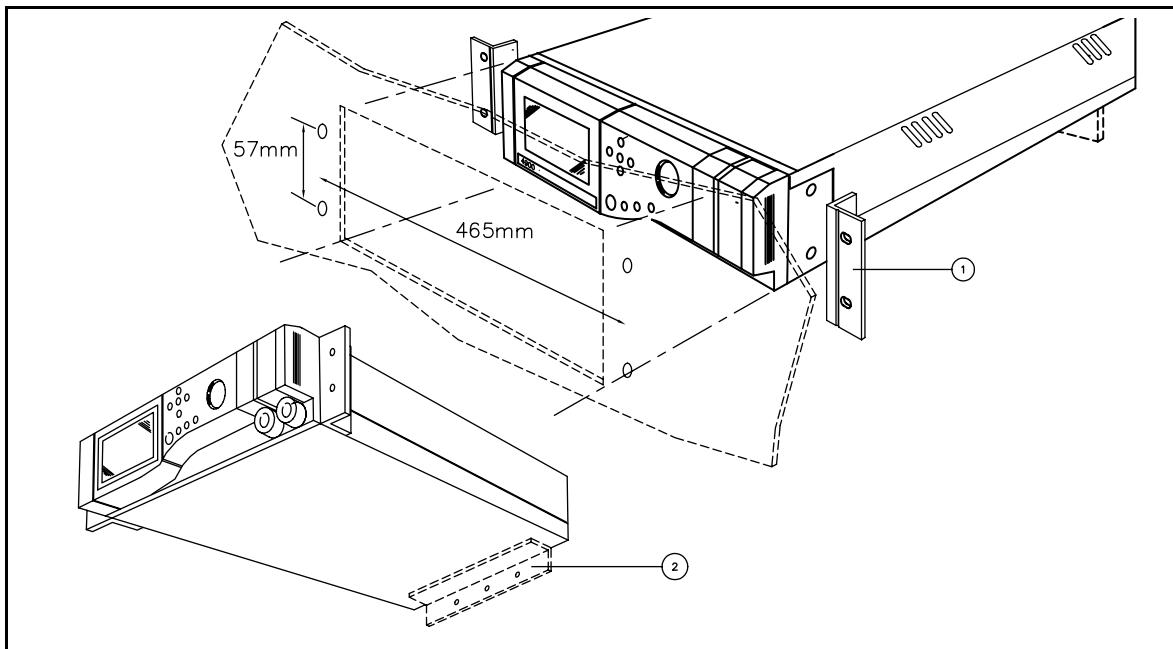

Figure 2.1: Panel mounting detail.

Key: 1 Mounting brackets
 2 Additional Support (customer supplied)

Note: Cut-out dimensions of 447mm x 134mm mounting holes should be M6 or 7mm clearance

2.5 Rack slide mounting installation

The analyser occupies 3U/5.25"/133mm of rack space. Determine at what height the analyser is to be installed in the rack enclosure. The analyser will occupy nine rack flange cage nut positions. Note that intermediate cage nut positions need not be punched out.

If the instrument has been purchased with the rack mounting option then the rack slide inners will already be mounted on the analyser chassis. If the rack mounting kit has been purchased as a spare then the instructions in this section detail fitting. The rack mounting kit contains two slides which have an inner and outer section.

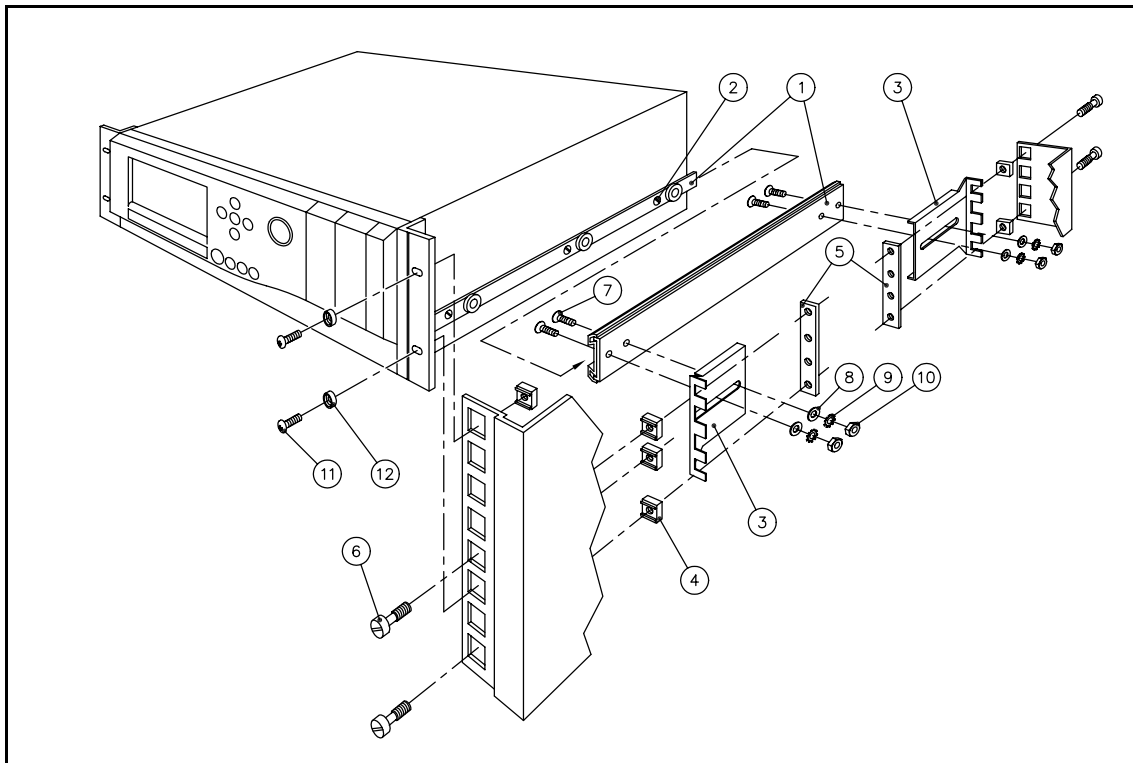

Figure 2.2: Rack installation exploded view

Key:	1	Telescopic slide	7	Screw, M4
	2	Screw M5	8	Washer, M4
	3	Slide support bracket	9	Locking washer, M4
	4	Cage nut	10	Nut, M4
	5	Slide support clamp	11	Screw, plated, cross head, M5
	6	Waisted screw, brass, M5	12	Cup washer, plastic

See Figure 2.2. The 19" optional rack slide mount version is supplied with a mounting kit which includes either long or short slides and rack mounting brackets. Do not attempt to support or carry the analyser by the rack mount brackets. The analyser is suitable for installation in most standard rack types including Schroff and Rittal, thus:

- Remove the inner section from each slide (item 1) and fix one to each side of the chassis using 3 screws (item 2) for 4902 models or 4 screws (item 2) for 4904 models.
- Counting from the bottom cage nut position, install cage nuts (item 4) in positions 1,3,4 and 8 on front two rack enclosure flanges. Install cage nuts in positions 1 and 4 on rear two rack enclosure flanges.
- Insert the two waisted screws (item 6) fully into front cage nuts, positions 1 and 4, on both front and rear rack enclosure flanges.
- Present the slide support clamp (item 5) behind the rack enclosure front flange, and line up with cage nut positions 1 and 4.
- Engage the two waisted screws (item 6) in the slide support clamp, but do not tighten.
- Fit the slide support (item 3) between the cage nuts (item 4) and the slide support clamp (item 5), note that the front slide supports face backwards and the rear slide supports face forwards.
- Tighten the two waisted screws (item 6) to clamp the slide support (item 3) between the cage nuts (item 4) and the slide support clamp (item 5).
- Loosely fit the two rack slide outer sections (item 1), to the slide supports (item 3) in four places using fixings (items 7,8,9,10). Note that the slide outer section item 1 should be mounted so that the slide inner (item 1) slides in from the front.
- Position the rack slide outer sections (item 1) so that the front edge is 35mm behind the rack enclosure front flange. Tighten the fixings (items 7,8,9,10).
- Install the analyser in the rack locating the inner slide section (item 1) inside the outer slide section (item 1).
- Secure the analyser into the rack cabinet using the screws (item 11) and the plastic cup washers (item 12).

NOTES

SECTION 3 INSTALLATION - ELECTRICAL

WARNINGS

- **The installer must be satisfied that the 4000 series analyser installation conforms to the relevant safety requirements, National Electrical Code and any other local regulations, and that the installation is safe for any extremes of conditions which may be experienced in the operating environment of the analyser.**
- **This appliance must be connected to a protective earth.**
- **To comply with the European Community EMC Directives the interconnecting cables used for all input, analogue output and serial output should be screened or equivalent protection provided.**
- **For compliance with EMC emissions and susceptibility standards the functional earth must always be connected to a local EMC ground.**

3.1 Electrical power connection

Electrical power is connected to the chassis via an IEC appliance adaptor located on the rear of the chassis (refer to Figure 1.1). The analyser will already be configured for the mains voltage range ordered ('85 to 132V' or '170 to 264V').

The analyser should be connected to a clean, single phase electrical power supply meeting the requirements of 'Installation category II', at a voltage within the range selected. The electrical power supply should be fused at a value to protect the power cord. The UK power cord already has a 5A fuse fitted for this purpose otherwise it is recommended that the electrical power supply is fused at 6A.

The user must ensure that when installed in a rack, cabinet or other fixture, the mains switch is readily accessible or where this is impractical, the installation must be provided with a separate means of disconnecting power which complies with the relevant local and national standards.

Should the user connect a different power cord to the one supplied, this must be wired in accordance with national and local regulations. After wiring the power cord, check earth continuity from the power connection earth to the functional earth on the rear of the chassis (see Figure 1.1).

The voltage setting may be changed as follows. The fuse value must be changed when the voltage setting is changed:

- Unplug the mains connector.
- Remove the voltage selector, a screwdriver may be used in the slot at the top of the voltage selector to aid ejection.
- Rotate the voltage selector through 180° so that the required voltage is shown at the bottom of the voltage selector.

- Fit fuse F2 to the right hand side of the voltage selector according to the voltage selected. Voltage selector position 220/240V for 170 to 264V operation fit fuse T3.15A HBC to IEC 127 (Figure 3.1). Voltage selector position 110/120V for 85 to 132V operation fit fuse T5.0A HBC to IEC 127 (Figure 3.2). **If a 20mm fuse is used then ensure that the fuse does not extend into the spring clips provided for a 1 inch fuse.**

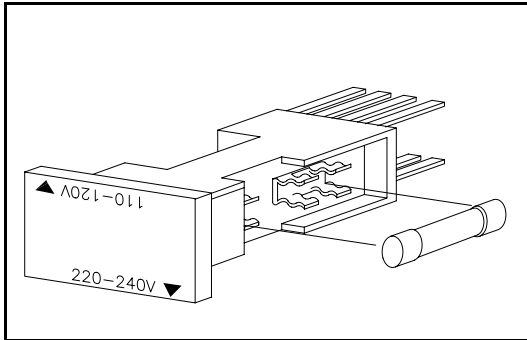

Figure 3.1: Position of F2 in voltage selector for 170V to 264V operation

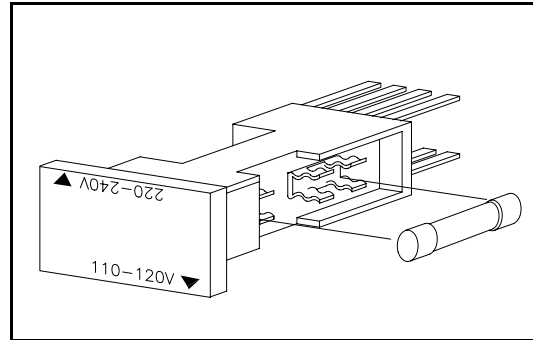

Figure 3.2: Position of F2 in voltage selector for 85V to 132V operation

3.2 Signal connections

CAUTION

The current outputs must not be allowed to exceed 30vrms (42.4vpeak) or 60 volt DC to earth when connected to associated equipment.

It is recommended that the analyser is switched off while signal leads are being connected or disconnected. Signal terminals are located on the rear of the analyser and are identified as sockets PL1 to PL5. Two sockets PL1 and PL5 are always fitted, PL2, PL3 and PL4 sockets are present only when the corresponding option cards are fitted. PL8 is located on the gland plate when the autocal option is fitted.

A loose 14-way socket connector with accessories is provided to make connections to each plug. The plugs and sockets are keyed so that the sockets may only be located in the correct plug position. The loose socket covers have an identification number which corresponds to the mating plug. Ensure that each socket is always fitted with the correct covers. The separate covers on PL1 to PL4 provide segregation between current output and relay wiring. The sockets and cover must always be fitted and secured, even when signals are not required. Figure 3.3 shows the assembly of plugs PL1 to PL4 with segregated covers. The assembly for plug PL5 is similar but with a single 14-way cover provided. Plug PL8 is similar but has only 7-ways.

The loose sockets have screw terminal connections. These will accept a flexible conductor which has a cross sectional area in the range 20 AWG to 16 AWG, 0.5 to 1.5mm² or a solid conductor which has a cross sectional area in the range 20 AWG to 14 AWG, 0.5 to 2.5mm². Solid conductors larger than 18 AWG, 1mm² are difficult to dress inside socket covers and are therefore not recommended.

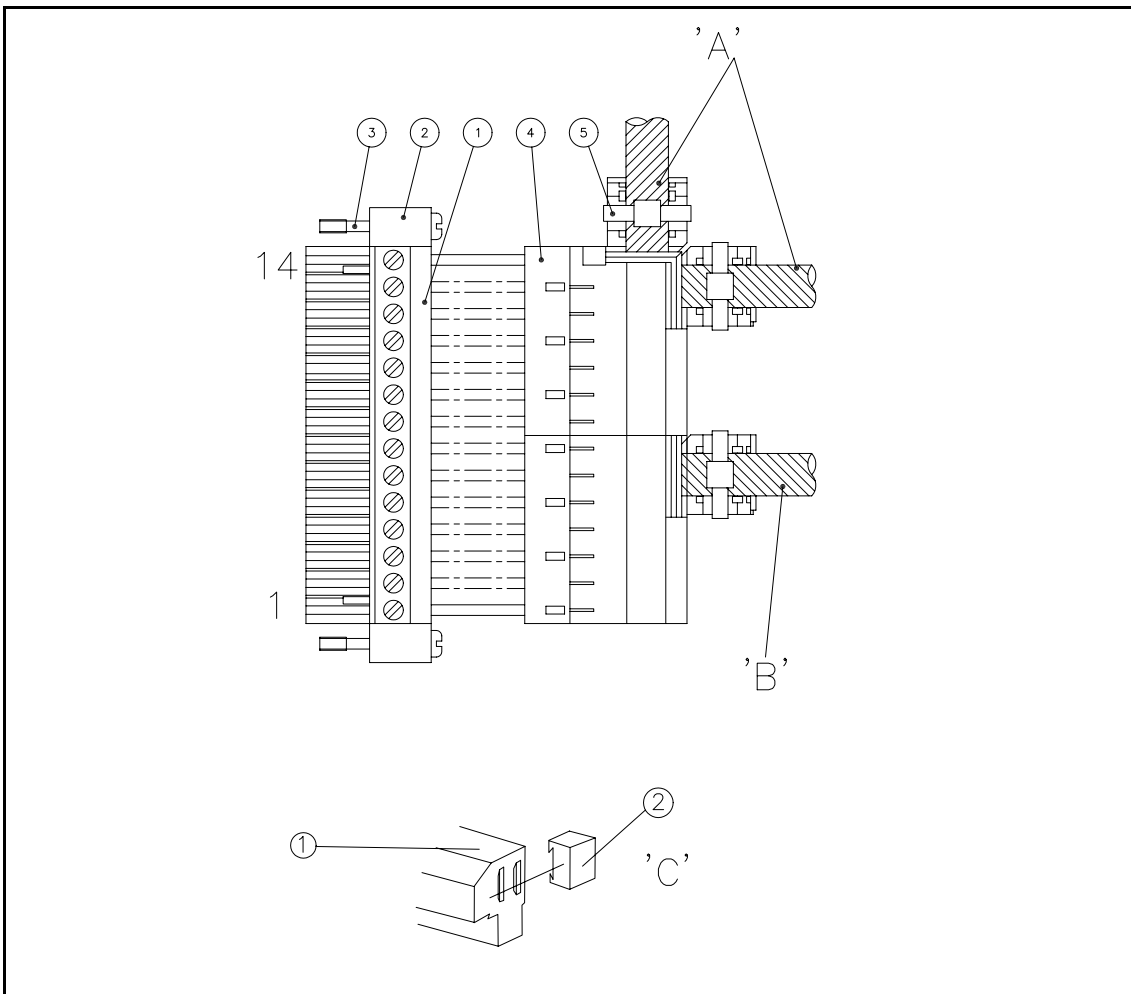

Figure 3.3: Signal socket assembly

Key:	1	Screw terminal block	4	Cover
	2	End block	5	Cable tie
	3	Jacking screw		

Notes	A	Relay cabling may use either entry
	B	Analogue output cabling
	C	Mount item 2 by sliding them onto the dovetails in item 1

For compliance with EMC standards connections to current outputs must use screened or shielded cable, with either separately screened pairs or two pairs with an overall screen. The screens (or drain wire for foil screens) must be terminated at pin 1 or pin 6 (both if separate screened pairs are used).

All mA inputs and associated status lines (plug PL5) must use screened or shielded cables with the screen or drain wire terminated at the terminals marked 'screen' on the connector.

Remaining signal inputs (plug PL5, terminals 11 to 14) must use screened or shielded cables with the screen or drain wire terminated at the screen stud (M4) adjacent to PL5.

The use of screened signal cables is recommended in all installations

After wiring the loose sockets, the covers must be re-fitted for safe operation. To avoid straining the screw terminal connections attach the cable sheath to the cover by trimming and folding out the appropriate section of the cover and securing the cable to it using the cable tie provided. Clip the remaining cover sections into place around the cable.

The loose sockets are provided with end blocks and jack screws which must be fitted and used to secure them to the corresponding plug. Do not over tighten screws.

The signal terminals each have a legend indicating their function.

3.2.1 mA output and relay output connections

Plugs PL1 to PL4 provide the analogue output and relay output electrical connections. Refer to Table 3.1. The option card population may be determined by visual inspection.

Plug PL8 provides additional relay output electrical connections for autocalibration connections only. Refer to Table 3.2.

WARNING

If the external circuits connected to PL1, PL2, PL3, PL4 and PL8 are at a voltage exceeding 30Vrms (42.4V peak) or 60V dc the following precautions must be observed to prevent an electric shock hazard:

- a) The external circuits connected to PL1, PL2, PL3, PL4 and PL8 must not be powered with the connector unplugged.**
- b) The analyser must be mounted in a rack, enclosure, cabinet or similar fixture and have the external cabling for PL1, PL2, PL3, PL4 and PL8 secured as close as practical to the connector. This is to prevent strain on the cable pulling the cover from the socket.**
- c) Fit covers to loose sockets.**

Do not exceed the specified relay rating of 264V rms maximum and 1A maximum.

NOTE

For reliable operation, relays should switch not less than 10mA.

Table 3.1: Signal terminal location PL1 to PL4					
Terminal number		PL4 (optional)	PL3 (optional)	PL2 (optional)	PL1
T o p c o v e r	14	Screen	Screen	Screen	Screen
	13	Relay 4.5A	Relay 3.5A	Relay 2.5A	Relay 1.5A
	12	Relay 4.5A	Relay 3.5B	Relay 2.5B	Relay 1.5B
	11	Relay 4.4A	Relay 3.4A	Relay 2.4A	Relay 1.4A
	10	Relay 4.4B	Relay 3.4B	Relay 2.4B	Relay 1.4B
	9	Relay 4.3A	Relay 3.3A	Relay 2.3A	Relay 1.3A
	8	Relay 4.3B	Relay 3.3B	Relay 2.3B	Relay 1.3B
B o t t o m c o v e r	7	Screen	Screen	Screen	Screen
	6	Screen	Screen	Screen	Screen
	5	mA 4.2 -	mA 3.2 -	mA 2.2 -	mA 1.2 -
	4	mA 4.2 +	mA 3.2 +	mA 2.2 +	mA 1.2 +
	3	mA 4.1 -	mA 3.1 -	mA 2.1 -	mA 1.1 -
	2	mA 4.1 +	mA 3.1 +	mA 2.1 +	mA 1.1 +
	1	Screen	Screen	Screen	Screen

Table 3.2: Optional external autocalibration connections PL8		
Terminal		Function
1	Screen	
2	Relay 0.1B	Default relay contacts for group 1 valve 1 Sample / Calibration selection (if fitted)
3	Relay 0.1A	
4	Not Used	
5	Relay 0.2B	Default relay contacts for group 1 valve 2 Cal. Gas 1 / Cal. Gas 2 selection (if fitted)
6	Relay 0.2A	
7	Screen	

The standard relay output defaults are as follows:

- 1.3 CAL IN PROG (Calibration in progress)
- 1.4 MAINTENANCE
- 1.5 FAILURE

All other relays are unassigned, except (where external autocalibration is fitted):

- 0.1 GROUP 1 SAMPLE/CAL
- 0.2 GROUP1 CAL1/CAL2

The standard analogue output defaults are:

- 1.1 TXD (transducer) 1
- 1.2 TXD 2
- 2.1 TXD 3
- 2.2 TXD 4

All other extra analogues are unassigned. The R1 defaults for each analogue are:

L=0%FSD, U=100%FSD (Gfx's have variable low ranges, so their R1 limits will need to be individually set in L1), 4-20mA, LOW LIMIT 3.6mA, FREEZE, JAM LOW

3.2.2. Analogue inputs

Plug PL5 provides the electrical connections for the analogue inputs, the autocalibrate initiate input (function detailed in Section 3.4) and the range change input. The connection details for PL5 are summarised in Table 3.3.

Each analogue input signal consists of an analogue current input (for example pins 1 and 2 on PL5 for analogue input 1) plus a digital status input (for example pins 9 and 10 on PL5 for analogue input 1). The status input defines the validity of the analogue input signal. A high input, or open circuit, on the digital signal indicates that the data is invalid. A low input, or short circuit, on the digital signal indicates that the data is valid. Connection in this way ensures that disconnection of the analogue input source or removal of the connector from PL5 will result in an invalid measurement indication. If no suitable status indication is available from the source of the analogue input signal then the status input pin should be shorted to the neighbouring ground pin within the PL5 connector.

NOTE

If the analogue input status signal is not connected then the digital line will be pulled high internally. This indicates that the data is invalid and no reading will be measured.

The external range change input is located at pins 13 and 14 of connector PL5 (see Table 3.3). The second analogue output range for all outputs is obtained by shorting these two pins together or by providing a digital low signal to pin 14.

Table 3.3: Signal terminal location PL5			
Terminal	Function	Terminal	Function
1	Analogue input 1 +ve	8	0V
2	Analogue input 1 -ve	9	Analogue input 1 valid
3	Analogue input 2 +ve	10	0V
4	Analogue input 2 -ve	11	0V
5	Screen	12	Auto calibration initiate
6	Screen	13	0V
7	Analogue input 2 valid	14	Range change

3.2.3. External autocalibration connection

The external autocalibrate initiate input is located at pins 11 and 12 of connector PL5. The autocalibration facility is started by shorting these two pins together or by providing a digital low signal to pin 12.

NOTE
The external autocalibration initiate signal should be applied for at least 2 seconds, (but less than 30s) to ensure that the input has been recognised.

For analysers configured with the external autocalibration option card, an additional output connector, PL8, is fitted into the sample gland plate at the rear of the analyser. This connector supplies two pairs of relay contacts which may be used to control external valves.

The following truth table applies to **any pair** of relay contacts utilised for autocalibration. These relay contacts are rated at 1.0A, 264V AC and 1.0A, 30V DC (non-inductive). Screened cable should be used to connect to solenoid valves of length not exceeding 3m with the screen terminated at the instrument end. It will be necessary to fit a suppression device across the coils of the solenoid valves. For DC supplies a diode is recommended. For AC supplies a 0.047uF capacitor in series with a 100Ω resistor would generally be found satisfactory.

Table 3.4: External autocalibration truth table		
Gas Required	Relay Contacts for Valve 1	Relay Contacts for Valve 2
Sample Gas	De-energised (OPEN)	De-energised (OPEN)
Calibration gas 1	Energised (CLOSED)	De-energised (OPEN)
Calibration gas 2	Energised (CLOSED)	Energised (CLOSED)

Depending on the number of autocalibration groups, at total of 2, 4, 6, or 8 relays will be needed to control up to eight external valves. The relay output electrical connections can be made to any combination of PL1, PL2, PL3, PL4 and PL8. Refer to Quickstart manual for autocalibration set up, this will automatically clear any existing relay allocation. Table 3.1 and 3.2 contain the pin out details.

3.3 Serial data/Modbus connection

The serial data connection is provided via the 9 pin 'D' type connector (PL6) located on the rear of the instrument. Both RS232 and RS485 interfaces are supported as shown in Table 3.5

NOTE

The RS232 and RS485 interfaces are non-isolated. When using the RS485 interface with other non-isolated equipment, the difference in ground potentials must be no greater than $\pm 7V$.

For compliance with EMC standards, connections to PL6 must be made using a screened cable. The screen must be terminated at the EMI shielded 'backshell' or conductive cover of the 'D' type connector. Maximum total cable lengths are 3 metres for the RS232 interface, and 1200 metres for the RS485 interface. Note that the 4000 analyser includes RS485 line termination of 120 Ω .

Table 3.5: Serial output connections PL6		
Interface	Terminal	Function
RS232	2	Received data (RXD)
	3	Transmitted data (TXD)
	5	Signal common/ground
RS485	1	RS485- (B)
	6	RS485+ (A)

The serial data connection can be used in one of two ways. With the analyser configured to "Continuous" communications mode (refer to Quickstart manual) a data frame is transmitted at user-defined intervals. With the mode set to "MODBUS ASCII" or "MODBUS RTU" the analyser becomes a Modbus slave responding to commands or data requests from a Modbus master.

These communications modes are described in more detail in the following sections.

3.4 Continuous mode

In continuous mode a data frame is transmitted by the serial output port at a user defined interval. The format of the data frame is given in Table 3.6 and 3.7. However, it is a list of process variables (or 'fields') preceded by a start character, separated by semi colons and terminated by carriage return and line feed, i.e.:

A;B;C;D;E;F;G;H;I;J;K;L;M;.....;N;<CR><LF>

The frame frequency and generic communications parameters are configured in the analyser software (refer to Quickstart manual), note the 'frame frequency' sets up the frequency of transmission of the data frame down the serial communications port. For example if the value is set to 15 seconds then the output data frame will be transmitted once every 15 seconds. The frequency is set in steps of one seconds from 1 to 9999 seconds. If the value is set to zero then the transmission of data down the serial port stops and will not restart until a non zero value is entered.

Table 3.6: Serial output data frame, start and end sequences			
Field	Number of characters	Function	Entry/format
A	8	date	DD-MM-YY
B	8	time	HH:MM:SS
C	2	analyser failure and maintenance fault status	first character F for failure, second character M for maintenance (spaces = OK)
D	8	Autocalibration 'flags', two characters for each of the four calibration groups	first character: group 1, S for sample, C for calibration gas
			second character: group 1, 1 for cal gas 1, 2 for cal gas 2
			etc, for groups 2, 3 then 4
E	2	number of process measurements or 'variables'	03 to 07 , the following fields will be repeated for each transducer and any derived measurements. The last two variables will always be the two external inputs (E1, E2)
F-M	measurement sequences, refer to Table 3.7		
N	4	check sum	e.g.: 096A
-	-	end code, <CR> and <LF>	ASCII code 13 and 10

Table 3.7: Serial output data frame, measurement sequences			
Field	Number of characters	Function	Entry/format
F	2	measurement identity	e.g.: I1 , D1 , E1
G	6	measurement name	e.g.: Oxygen
H	6	value	e.g.: 20.9
I	3	units	e.g.: %
J	4	alarms	one character for each alarm, 1,2,3,4 raised = alarm, space = OK
K	2	failure and maintenance fault status	first character F for failure, second character M for maintenance (spaces = OK)
L	1	calibration status	C in calibration, or space
M	1	warming up status	W warming up, or space
The above will be repeated for each measurement , (including derived) concluding with external inputs E1 and E2, before returning to end sequence.			

3.5 Modbus mode

The analyser supports both Modbus ASCII and Modbus RTU protocols (refer to Quickstart manual). Note that the serial port settings are shared by all communication modes and must be configured to valid settings for the mode in use.

Both RS232 and RS485 connections are provided and may be selected through the user interface (see Quickstart manual). The RS485 option also allows multidrop operation where more than one analyser may be connected to a single serial port on the Modbus master.

NOTE

In RS485 multidrop mode, each analyser must have a unique Modbus slave address. This can be set through the user interface.

In RS232 mode, a dedicated connection to the Modbus master is required and multidrop operation is not possible.

Appendix B describes how to access analyser data and control autocalibration using the Modbus protocol.

3.6 EMC Installation

The chassis must be securely bonded to the local EMC ground. In most installations this will be the back plate, cabinet walls or other access point to the local equipotential common bonding network. Connection to the analyser should be made using the shortest possible length of heavy-gauge braid. The braid should be clamped between the cable clamping washers provided on the functional earth terminal. This is an M5 stud located to the rear of the analyser, see Figure 1.1.

Interconnecting cables used for all input, analogue output and serial output should be screened, or equivalent protection provided, as described in Sections 3.2 and 3.3.

All cables should be routed along a low resistance parallel earth conductor to divert earth currents and allow the screened cables to be grounded at both ends.

The whole EMC ground bonding network should follow best practice so that the back plate, cabinet walls, parallel earth conductors and other structural elements of the installation form an equipotential common bonding network. The network should be connected as directly as possible preferably using metal-to-metal bonding at multiple points. Bonds should make good reliable low-resistance connections.

NOTES

SECTION 4 INSTALLATION – GAS CONNECTIONS

4.1 Introduction

Sample and calibration gases pass into and out of the chassis via a gland plate mounted on the rear of the chassis. The sample gland plate with or without external autocalibration provides up to four sample inlets and a corresponding outlet for each inlet, and an optional interface connector, PL 8. When optional internal paramagnetic autocalibration solenoid valves are used a manifold is mounted on the sample gland plate which provides ports for sample inlet and outlet, and inlets for low and high calibration gases for gas sensor module 1 only.

CAUTION

- **The condition of the gases supplied to the analyser depend on the analyser configuration. Full details are given in Section 7.**
- **Failure to comply with the specifications will result in damage to the analyser.**

4.2 Calibration gases

The gas mixtures recommended for calibration of the instrument will depend on the gas components measured by the transducers fitted to the gas stream and the measurement ranges of the transducers. The recommended gases are limited by the long term storage stability of the components of the mixture. Certain gas mixtures should be avoided as these will not be stable with time. For example gas mixtures containing (all of the following) O₂ and NO are not stable and should not be used.

Note, the 4900 analyser permits several sensors to be on a single sample stream. In such cases the selection of calibration gases for use with either internal or simultaneous external autocalibration will either have to facilitate the requirements of several transducers at the same time or be controlled by their own relay/solenoid. Examples of calibration gases (particularly for use with Gfx arrangements) are shown in Table 4.1, below.

Table 4.1: 4900C calibration gas examples		
Gas components measured	Calibration gas 1	Calibration gas 2
CO only <u>or</u> CO+O ₂	"zero grade" N ₂ *	CO in air gas mix
CO+CO ₂ <u>or</u> CO+CO ₂ +O ₂	"zero grade" N ₂	CO+CO ₂ in air gas mix
NO only <u>or</u> NO+O ₂	NO in N ₂ gas mix	Air
NO+CO ₂ <u>or</u> NO+CO ₂ +O ₂	NO in N ₂ gas mix	CO ₂ in air gas mix
SO ₂ only <u>or</u> SO ₂ +O ₂	"zero grade" N ₂ *	SO ₂ in air gas mix
CO+NO <u>or</u> CO+NO+O ₂	NO in N ₂ gas mix	CO in air gas mix
CO+SO ₂ <u>or</u> CO+SO ₂ +O ₂	"zero grade" N ₂ *	CO, SO ₂ in air gas mix
NO+SO ₂ <u>or</u> NO+SO ₂ +O ₂	NO in N ₂ gas mix	SO ₂ in air gas mix

Note: the following presumes that background gases, in the typical sample stream, will have no effect on the sensor readings. If this is not the case, calibration gases should be modified accordingly.

4.2.1 Gfx transducer low and high calibration

The low calibration gas for Gfx gas sensor modules may be specified between -5vpm and +5vpm of the measured component. Zero grade nitrogen is recommended.

The high calibration gas can be in the range 6 to 110% of the transducer's FSD. As Gfx sensors are configured as 'dual range' units, it is recommended that the high calibration gas is selected at the top end of the range used.

4.2.2 IR transducer low and high calibration

Typically zero grade nitrogen is recommended for low calibration.

It is recommended that the high calibration gas is in the range 80 to 110% of the transducer's FSD.

4.2.3 Paramagnetic transducer low and high calibration

The low calibration gas for paramagnetic gas sensor modules may be specified between -3% and +3% oxygen. This is to allow for the situation where the background gas affects the paramagnetic zero (see Appendix A). Zero grade nitrogen is recommended.

The high calibration gas can be in the range 5 to 100% oxygen. For purity measurements a high calibration gas with approximately 100% oxygen is recommended, for other paramagnetic transducers 21% (air) is adequate.

This gas can also be used to calibrate the Pm Pressure sensor.

NOTE

Pure dry air can be used, but not if it has been passed through molecular sieve driers since its composition may have been altered significantly.

4.2.4 Zirconia transducer low and high calibration

The low calibration gas must be a high quality certified mixture of pure background gas (usually nitrogen N6.0) containing trace oxygen. Mixtures containing between 100 and 1000vpm oxygen are preferred, however, lower concentrations may be used.

The high calibration gas must be pure dry air containing 209500vpm oxygen (i.e. 20.95% volume).

CAUTION

It is essential that all gases supplied to zirconia transducers are filtered to 2 μ m local to the analyser and that great care is taken to ensure that there is no possibility of ingress of dirt, swarf or any other kinds of particle during connection or operation.

4.3 Gas connections

Gas connections are made to the rear of the analyser. The actual connection depends on the analyser variant and the sensor selection. Refer to Table 4.2 through Table 4.4.

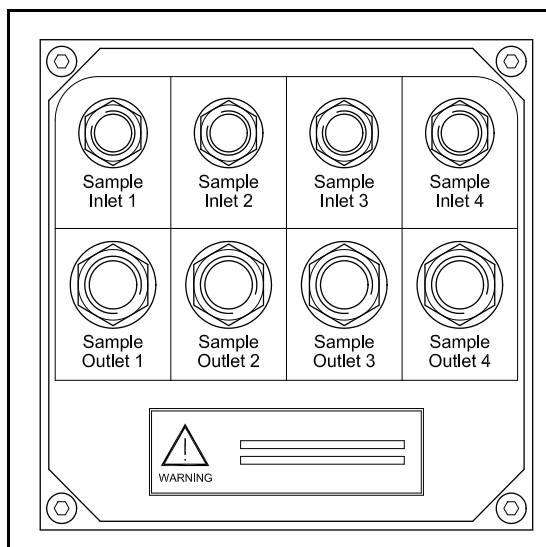

Figure 4.1: Sample gland plate without autocalibration

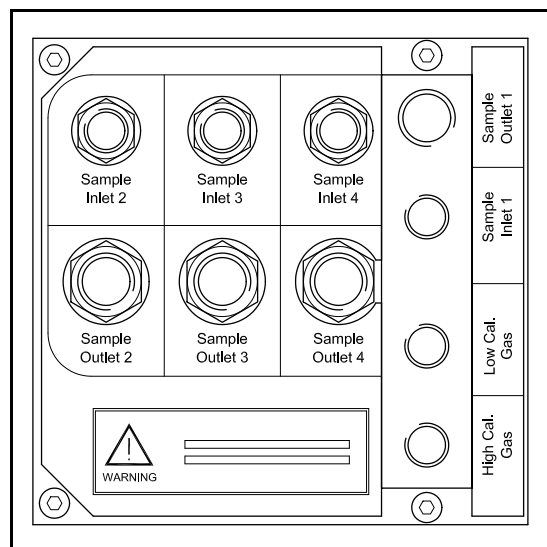

Figure 4.2: Sample gland plate with internal autocalibration

Note, the gland plate for external autocalibration is similar to Figure 4.1, except that an additional electrical connector (PL 8) is installed underneath the gas ports.

Table 4.2: 4100C and 4200C sample port vs transducer type				
Gas sensor module type	Sample inlet	Sample outlet	Low cal gas	High cal gas
Zirconia	1/8" OD* stainless steel stub	1/4" NPT female	N/A	N/A
1520 Series IR	1/8" NPT female	1/4" NPT female	N/A	N/A
Paramagnetic	1/8" NPT female	1/4" NPT female	N/A	N/A
Infrared Gfx	1/8" OD* stainless steel stub	1/4" NPT female	N/A	N/A
Internal auto cal	1/8" NPT female	1/4" NPT female	1/8" NPT female	1/8" NPT female

*Note: **An external filter** may be specified, in which case the inlet connections will be 'Swagelok' 1/8" OD female compression. The filter should be fitted directly to the analyser inlet or, if preferred, at a convenient point in the sample inlet line.

Table 4.3: 4210C sample port type				
Gas sensor module type	Sample inlet	Sample outlet	Low cal gas	High cal gas
All sensor types	1/8" OD* stainless steel stub	1/8" OD* stainless steel stub	N/A	N/A

*Note: **An external filter** may be specified, in which case the inlet connections will be 'Swagelok' 1/8" OD female compression. The filter should be fitted directly to the analyser inlet or, if preferred, at a convenient point in the sample inlet line.

Table 4.4: 4900C sample port type				
Gas sensor module type	Sample inlet	Sample outlet	Low cal gas	High cal gas
Standard	1/8" NPT female	1/4" NPT female	N/A	N/A
With internal Auto Calibration	1/8" NPT female	1/4" NPT female	1/8" NPT female	1/8" NPT female

WARNING
<ul style="list-style-type: none"> • Verify that connections are leak free at full operating pressure before applying sample or calibration gases. These gases may be flammable, toxic or asphyxiant. • Consideration should be given to the flammable, toxic and asphyxiant nature of the sample gas when selecting a vent location.

4.4 Reading flowmeters

The optional flow monitors are provided to control and measure the flow of sample gas through the analyser. The flow monitor consists of an optional needle valve (4900C only) and a rotameter type flowmeter. The reading of the flow rate through the flowmeter is obtained by observing the scale indication at the **top** of the float.

4.5 Autocalibration overview

The autocalibration facility allows the instrument's calibration to be updated or checked without user intervention.

When external autocalibration valves or an internal autocalibration manifold are fitted, a manual calibration adjustment or calibration check will use the autocalibration valves to select the calibration sample gases as required.

The autocalibration process can be initiated in four ways:

- by an internal timer;
- by an external contact closure (refer to Section 3.4);
- by operator request through the user interface;
- or by an external Modbus command.

Autocalibration facilities are offered to either measure or check the following:

- Transducer low calibration ('zero' calibration).
- Transducer low and high calibration (both 'zero' and 'span').

In autocalibration two user defined gases (cal gas 1 and cal gas 2) are provided to the instrument. These gases may be either for low or high calibration of the transducers. In some cases the same gas may be used for low calibration of one transducer while being the high calibration of another. The gases are introduced to the analyser in three phases:

Phase 1	cal gas 1
Phase 2	cal gas 2
Phase 3	cal gas 1 again.

Any of the transducers connected to any sample inlet may be autocalibrated, either simultaneously or, by the use of calibration groups (see later in this section), completely independently.

NOTE

In the 4900C analyser, internal autocalibration can only be configured to calibrate all of the transducers on stream 1.

The following parameters must be set up for either autocalibration or autocheck:

- The time and date must be correctly set before using autocalibration.
- Selection of 'LOW' or 'LOW & HIGH' autocalibration (zirconia sensors cannot have a high autocalibration).
- LOW and HIGH calibration gas concentrations.
- Autocalibration period (i.e. time interval between successive autocalibrations; minimum one hour, maximum 59 days + 24 hours).
- Date and time of start of cycle (first autocalibration).
- Flush Time - this may be set, to suit the installation, to a value between 0.5 and 16 minutes so that each gas concentration stabilises before being read. After each flush time the gas will flow for an additional minute to allow the new 'calibrated' level to be viewed or recorded.
- Selection of autocalibration or autocheck.
- Calibration gas relays (if analyser relays are to be used, the alternative being control by external monitoring of the RS-232 output).
- It is necessary to specify which calibration gas (1 or 2) is used for the LOW calibration of each sensor.

Calibration groups

Autocalibration allows up to four independently programmable transducer groups. Groups of transducers are programmed independently but only one autocalibration can be performed at any one time. A queuing mechanism is used to ensure that autocalibrations are performed as soon as possible, if another autocalibration was taking place at the intended start time.

Autocalibrations initiated by the internal timer, the user interface or by Modbus commands may specify an individual calibration group. Autocalibrations initiated by an external contact closure will be carried out on all groups in sequence (it effectively causes all groups to be placed in the queue in sequence). Autocalibration will only be performed for non-empty groups that are enabled, and have their gas control relays assigned. This input will be ignored if an autocalibration is already in progress.

4.6 Autocalibration valve installation

As a general guide, two **externally powered** three way valves are required for each transducer to be calibrated. One switches between sample gas and the second 'calibration' valve (which switches between calibration gas 1 and calibration gas 2).

Autocalibration valves may be controlled either by the RS232 output (see Section 3.3) or by relays on the rear panel of the analyser (refer to Section 3.2 and Section 3.6).

Figure 4.3 and Figure 4.4 show typical installations and assume that, in the de-energised states, the lower port on the valves will be normally open (NO). The latter figure actually demonstrates the potential to utilise independent autocalibration even when several transducers are on a single sample stream (ref 4900C).

NOTE

The CAL1/CAL2 valve is only used during calibration. In the case of fully independent autocalibration, it is permitted to connect all CAL1/CAL2 valves to one relay, and configure the software accordingly. However, a dedicated SAMPLE/CAL solenoid/relay is required for each group.

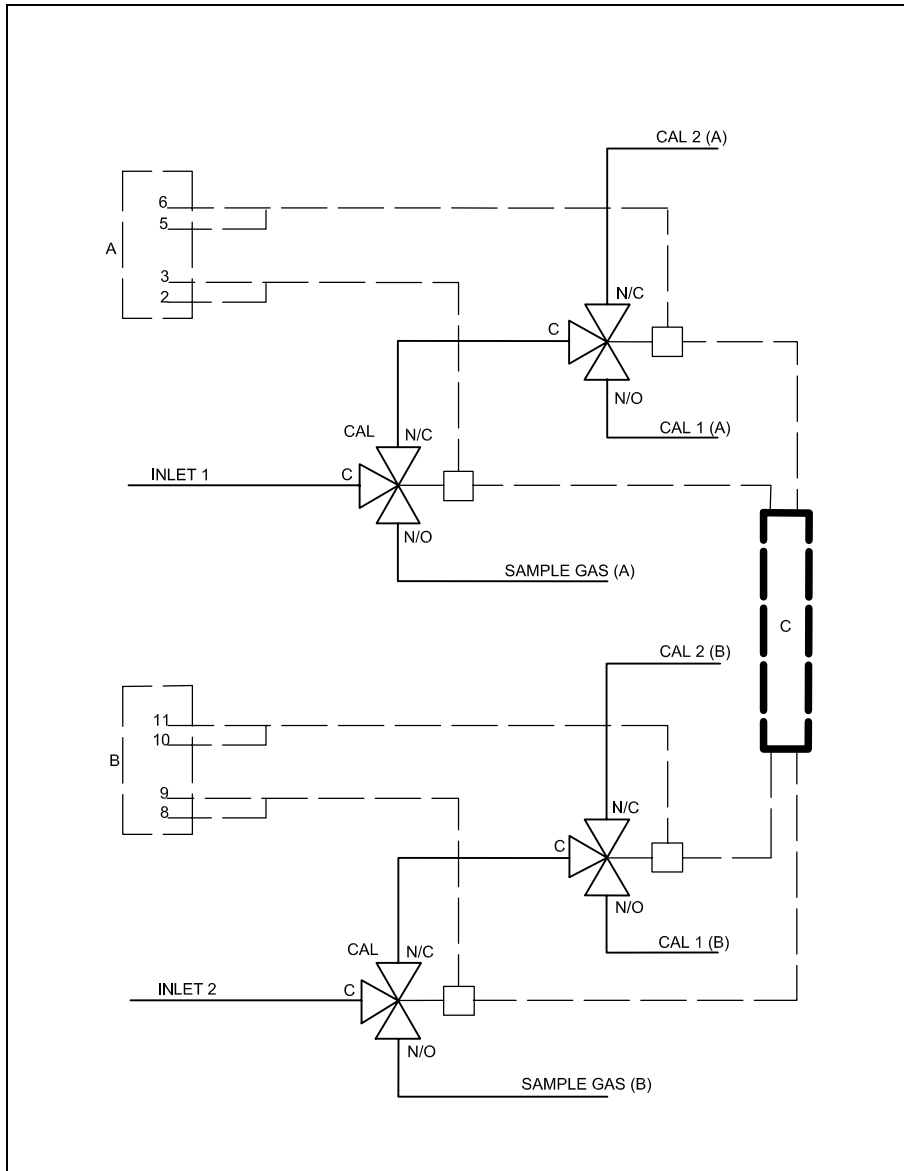

Figure 4.3: External autocalibration - parallel systems

- Key:
- INLET 1, gas connection to analyser inlet 1
 - INLET 2, gas connection to analyser inlet 2
 - SAMPLE A, gas connection to sample gas 1
 - SAMPLE B, gas connection to sample gas 2
 - CAL1 (A), gas connection to calibration gas 1 associated with transducer 1
 - CAL2 (A), gas connection to calibration gas 2 associated with transducer 1
 - CAL1 (B), gas connection to calibration gas 1 associated with transducer 2
 - CAL2 (B), gas connection to calibration gas 2 associated with transducer 2
 - A, wiring to analyser option board, in this example PL8 (external autocal)
 - B, wiring to analyser option board, in this example PL1, 2, 3 or 4
 - C, external power supply

A similar arrangement may be used for up to four inlet ports.

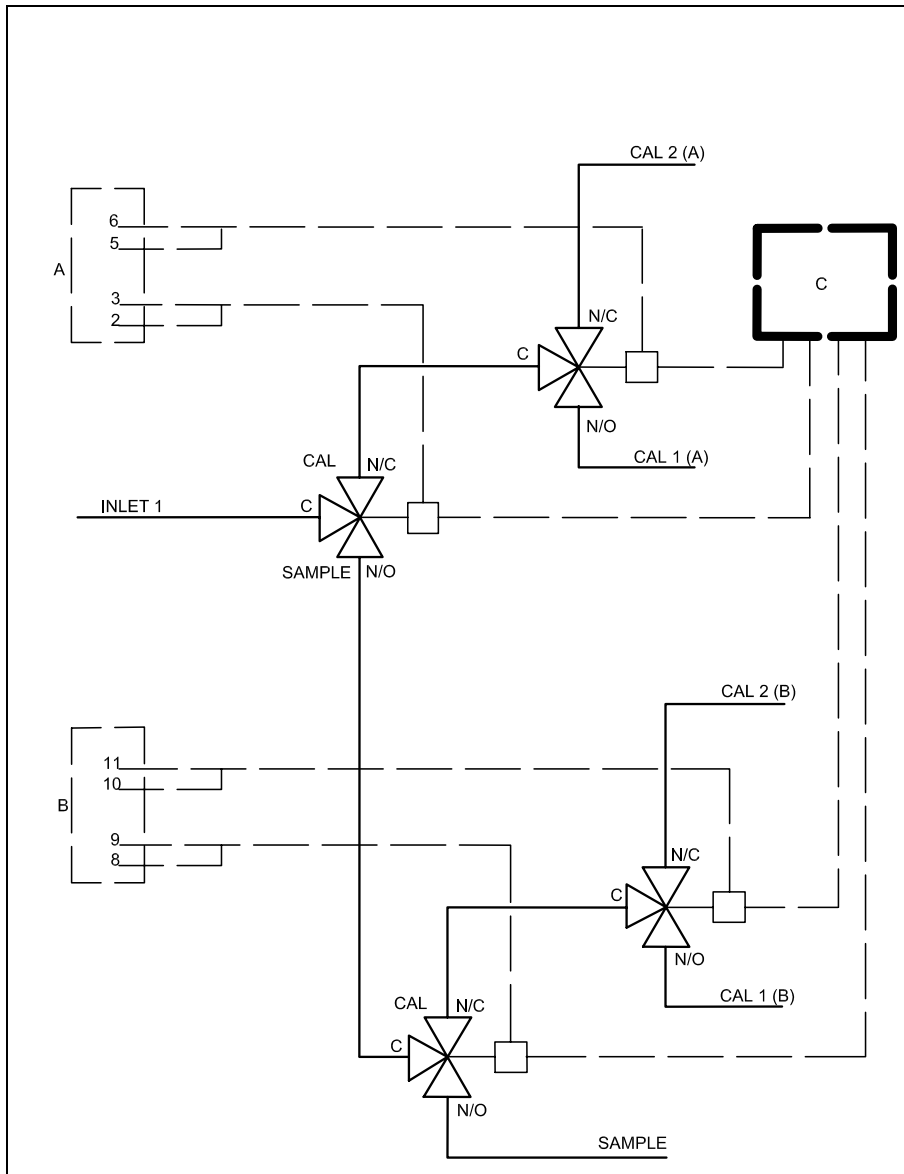

Figure 4.4: External autocalibration - stream systems

Key: INLET 1, gas connection to analyser inlet 1
 SAMPLE, gas connection to sample gas
 CAL1 (A), gas connection to calibration gas 1 associated with transducer 1
 CAL2 (A), gas connection to calibration gas 2 associated with transducer 1
 CAL1 (B), gas connection to calibration gas 1 associated with transducer 2
 CAL2 (B), gas connection to calibration gas 2 associated with transducer 2
 A, wiring to analyser option board, in this example PL8 (external autocal)
 B, wiring to analyser option board, in this example PL1, 2, 3 or 4
 C, external power supply

A similar arrangement may be used for up to four transducers on up to two inlet ports.

4.7 Power up

WARNING

Conditions for safe use with flammable samples (4200 and 4210):

Do not operate the power switch on the rear panel of the analyser if the unit is known to contain a flammable sample mixture.

The 4200 or 4210 must not be used in the event a display failure is observed.

The analyser may now be powered up. Please refer to the Quickstart manual for details of analyser set-up.

SECTION 5 ROUTINE MAINTENANCE

5.1 Replacing fan filter element

The external fan filter element should be checked every six months in laboratory conditions, for environments with a high dust content this period should be reduced. The filter element is washable and in laboratory or light dust conditions may be washed and refitted rather than replaced.

- Remove power from the analyser and unclip the filter cover complete with filter element and plastic gauze.
- Remove the plastic gauze and old filter element from the cover.
- Fit new filter into cover followed by plastic gauze.
- Clip cover back onto fan.

CAUTION

After washing the filter, ensure that it is completely dry before refitting.

5.2 Replacing the sample filter element

The front panel sample filter elements should be replaced every six months. External filter elements may be replaced annually, or more frequently if necessary.

WARNING

Sample and calibration gases may be toxic or flammable. Stop sample flow into analyser to avoid releasing gas into atmosphere when sample filter cap is removed.

1. Stop sample flow to analyser.
2. Use spanner (provided for front panel filter) to unscrew sample filter cap. Support the body of the external unit as necessary.
3. Remove old filter element and, on front panel filters only, the rubber 'O' ring. (The external element may be tapped lightly on the side to break it loose from the tapered seating area).
4. Fit new sample filter and (internal units only) rubber 'O' ring. Check that rubber 'O' ring is properly seated on the filter cap. (The external element should be tapped lightly with a smooth faced tool to reseal).
5. Fit sample filter cap and tighten using spanner.
6. Verify that there are no leaks by testing with a proprietary leak detection solution.

5.3 Cleaning

The exterior of the analyser should be regularly cleaned using a slightly damp cloth. Remove power before cleaning. Ventilation holes must be kept clear. Do not use solvents or abrasive cleansers to clean the analyser.

5.4 Toxic/flammable samples - routine leak test

WARNING

If toxic and /or flammable samples are being analysed it is essential to check the analyser and associated sample lines/system for leaks (every 6 months). MAX pressure that may be applied to each module is 8psig (5psig for the 4900C), however, this must be applied and removed slowly to both the inlet and outlet simultaneously to avoid damage to the measuring sensors.

SECTION 6 SPARES

Spare parts may be ordered from Servomex (addresses shown on the back cover of the manual). When ordering spares always give the model and serial number of your analyser. The analyser serial number is on the identification label on the underside of the analyser, and can be displayed via the user interface (refer to Quickstart manual).

WARNING

There are no user serviceable parts inside the analyser. Refer servicing to qualified personnel. Removal of the enclosure lid may invalidate the instrument warranty.

The following spares are required to maintain normal operation of the analyser.

Part Number	Description	Quantity
S4100KITA	Spares kit, one years operation	1EA
S4100KITB	Spares kit, two years operation	1EA
2377-3848	Stainless steel element for external filter	A/R

The spares, overleaf, are available for specific maintenance of the analyser.

Part Number	Description	Quantity
04000003C	QuickStart operator manual, English	1 ea
04000013C	QuickStart operator manual, French	1 ea
04000023C	QuickStart operator manual, German	1 ea
04000033C	QuickStart operator manual, Spanish	1 ea
04000005C	Installation manual, English	1 ea
04000015C	Installation manual, French	1 ea
04000025C	Installation manual, German	1 ea
04000035C	Installation manual, Spanish	1 ea
04000002C	Service manual, English	1 ea
S4000976	Kit, four tip up feet.	1 pk
S4000978	Mains fuses for 170-264V operation	1 pk
S4000979	Mains fuses for 85-132V operation	1 pk
S4000986	Kit socket 14W signal	1 ea
2388-1981	Filter element, 80mm Sq fan	1 pk
S4000984	Rack mount kit, short chassis	1 ea
S4000985	Rack mount kit, long chassis	1 ea
S4000987	Kit, internal fine filter cap and 'o' ring	1 ea
S4000988	Kit, internal filter elements 6µM	1 pk
2377-3831	Stainless Steel filter unit, complete (external)	1 ea

SECTION 7 TECHNICAL SPECIFICATIONS

7.1 Introduction

This section includes the technical specifications for all versions of the 4000. **The user must ensure that the relevant sub-sections are used for reference.**

It may be noted that similar transducer options are available in different analyser variants, in some cases the specifications for these will be application dependent.

(This performance specification has been written, and verified, in accordance with the international standard IEC 1207-1:1994 "Expression of performance of gas analysers").

7.2 Generic 4000 series analyser performance

7.2.1 Environmental specifications

Operating temperature:	4100C	5 to 40°C / 41 to 104°F
	4200C/4210C	5 to 40°C / 41 to 104°F
	4900C	5 to 45°C / 41 to 113°F
Storage temperature:	All analysers	-20 to 60°C / -4 to 140°F
Relative humidity:	10 to 90% HR, non-condensing.	
Atmospheric pressure:	79 to 124kPaa / 11 to 18psia (for operating altitudes to 2000m)	
Installation category:	II (local level power distribution with over voltage to withstand up to 2500Volts) in accordance with IEC 664	
Pollution degree	2 (normally electrically non-conducting pollutants) in accordance with IEC 664	
Warm up time:	Typically 1 hour from cold start at 20°C/68°F.	

7.2.2 Power supply

85 to 132Vac, 47 to 62Hz, 350VA maximum

170 to 264Vac, 47 to 62Hz, 350VA maximum

7.2.3 Design standards

The analyser complies with the "CE Marking Directive" 93/68EEC and conforms to the following normalised European standards for performance, product safety and electromagnetic compatibility:

EN61010-1

Safety requirements for electrical equipment for measurement, control and laboratory use.

EN61326+A1

Electrical equipment for measurement, control and laboratory use - EMC requirements.

7.2.4 Analogue outputs

Two isolated 0-20mA/4-20mA output with full zero and span adjustment as standard.

The user may define a second range by means of an external contact closure.

A maximum total of eight, two range outputs are available by selecting option cards.

Maximum impedance for each output is 1K Ω .

Maximum output current for each output is 20.5mA.

Maximum output voltage for each output is 27V.

7.2.5 Alarms

Three "volt free" single pole relay contacts rated at 264Vac/30Vdc @ 1.0Amp as standard.

Nine further general purpose relays are available by selecting option cards, however only four concentration alarms may be assigned to one transducer.

(Two similar relays are available as part of the 'external autocalibration' option. These contacts are used exclusively to control solenoid valves).

7.2.6 Serial data/Modbus connection

Single RS232/RS485 serial port, user configurable from 2400 to 19200 baud. This may be used as an ASCII data logging output or for communication using the Modbus protocol.

7.2.7 Analogue inputs

Two 'floating' (maximum common mode voltage 13V) 4-20mA/0-20mA linear inputs.

Associated digital input per channel to indicate data validity.

Intrinsic Error <0.02mA.

7.2.8 Digital inputs

Analogue input 1 valid.

Analogue input 2 valid.

Analogue outputs range change (contact closure).

Auto calibration initiate (contact closure).

7.2.9 Sample wetted materials

The following tables list sample wetted materials, firstly by sensor type, then by analyser model and configuration.

Table 7.1: Sample wetted materials						
Material	Sensor type:					
	Paramagnetic			Zirconia	1210 series Gfx	1520 series IR
	Basic	Control	Purity			
Stainless Steel 303	✓	✓	✓	✓	✓*	✓*
Stainless Steel 316	✓	✓	✓	✓	✓	✓
Viton	✓	✓	✓	✓	✓	✓
Polypropylene			✓			
Borosilicate glass	✓	✓	✓			
Platinum	✓	✓	✓			
Platinum Iridium alloy	✓	✓	✓			
Electroless Nickel		✓	✓			
Polyphenylenesulphide (PPS) carbon/PTFE filler	✓					
Stainless Steel 310				✓		
Alumina				✓		
Yttria Stabilised Zirconia				✓		
Nickel Iron				✓		
Sealing glass				✓		
Gold				✓	✓	
Calcium Fluoride					✓	
Nickel					✓	
Sapphire						✓
Epoxy resin						✓

*not in 4210 analysers

Table 7.2: Sample wetted materials, continued		
Feature	Analyser	Additional materials
Flow driven options	4100 4200	Polypropylene
Pressure driven options	4100 4200	Polysulphone Polypropylene
Stream systems	4900	Polysulphone Polypropylene Nylon*
Flowmeters	4100 4200 4900	Borosilicate Glass Duralumin
Needle valves	4900	Brass Fomblin Grease (suitable for oxygen service)
Flow alarm	4100⁽¹⁾ 4900	Glass Nylon Silicon Rubber Aluminium
Internal filter	4100 4200 4900	Polycarbonate Glass Fibre
External filter	4100 4200 4210	316 Stainless Steel
Internal Autocal	4100 4900	Aluminium PVDF

* - not in sample streams that include a Gfx

For the 4100 analyser go to page 7.5.

For the 4200 analyser go to page 7.9.

For the 4210 analyser go to page 7.12.

For the 4900 analyser go to page 7.15.

(1) This is only available on 4100C (Gfx flow driven) and 4900C product.

7.3 4100C analyser performance

WARNING

This analyser (4102C and 4104C) is not suitable for use with flammable or corrosive samples.

Internal autocal is unsuitable for use with toxic samples.

If toxic samples are present, the maximum pressure to the analyser must be limited to 8psig by means of a suitable pressure release system.

Sample requirements

For best performance the flow, or pressure, supplied to the analyser should be kept at a constant value for both normal sampling and for calibration gas input.

Temperature: 5 to 40°C / 41 to 104°F

Dew point 5°C / 9°F below minimum ambient

Condition: Oil free, non - condensing, filtered to 2µm

Vent: Each sensor outlet should be connected to a separate atmospheric vent, free from any back-pressure. (Consideration should be given to the toxicity and asphyxiant nature of the sample gas when selecting a vent location).

a) Flow driven options:

IR :	100 (min) - 250 (max) ml/min
Pm Purity:	100 (min) - 250 (max) ml/min
Pm Control:	100 (min) - 250 (max) ml/min
Pm Basic:	10 (min) - 100 (max) ml/min
Zr:	200 (min) - 550 (max) ml/min
Gfx:	500 (min) - 2500 (max) ml/min

b) All pressure driven options:

nominal	5psig / 35kPa
min.	2psig /14kPa, max. 8psig /56kPa

CAUTION

Do not exceed the rated flow or pressure as sensor damage may result.

Table 7.3: 4100C performance specification, oxygen				
Gases measured	Pm1111E O₂ Basic	Pm1158 O₂ Control	4100995 O₂ Purity	Zr 704 O₂ Trace
Range	0-25%	0-100%	0-100%	0-210000 vpm***
Min.rec.o/p range	0-5%	0-5%	0-0.5%	0-5 vpm
Intrinsic error	<0.15%	<0.15%	<0.02%	<0.1 vpm O ₂ **
Linearity error	<0.1%	<0.05%	<0.05%	<0.1 vpm O ₂ †
	inherently linear, dependant on calibration gases			
Repeatability	<0.1%	<0.1%	<0.01%	<0.1 vpm O ₂ †
Response (T90)	<15 s at 100ml/min	<15 s at 200ml/min	<12 s at 200ml/min	<15 s at 400ml/min
Zero drift / week	0.1% O ₂	0.05% O ₂	0.01% O ₂	<1% of reading or 250 vpb*
Span drift / week	0.1% O ₂	0.1% O ₂	0.02% O ₂	<1% of reading or 250 vpb*
Output fluctuation (peak to peak)	<0.1% O ₂	<0.05% O ₂	<0.01% O ₂ (in the range 99-100%)	<0.5% of reading or 10 vpb*†
Cross sensitivity	no effects in target applications			5 vpm H ₂ , 5 vpm CO, 5 vpm CH ₄ all <1 vpm O ₂
Ambient pressure coefficient	directly proportional to analyser vent pressure		<0.003% of reading for a 1% change in analyser vent pressure	no effect
Ambient temp. coeff./ 10°C change	2% of reading or 0.5% O ₂	1% of reading or 0.1% O ₂	0.2% of reading or 0.02% O ₂	1% of reading or 10 vpb*
Inlet sample pressure effect from 2 to 8psig	<2% of reading or 0.2% O ₂ *	<2% of reading or 0.1% O ₂ *	<0.1% O ₂	<0.15% of reading or 0.1% vpm*
Sample flow effect over full flow range	<2% of reading or 0.2% O ₂ *	<2% of reading or 0.1% O ₂ *	<0.1% O ₂	<0.15 vpm or <2 % of reading*

* whichever is the larger

† in the range 0-100vpm

** derived, dependant on calibration gases

*** indicative reading given above 21% O₂

Table 7.4: 4100C performance specification, Gfx				
Gases measured	Gfx 1210 CO Trace	Gfx 1210 CO₂ Trace	Gfx 1210 N₂O Trace	Gfx 1210 CH₄ Trace
Range (higher are available)	0-50 vpm	0-10 vpm	0-50 vpm	0-50 vpm
Min.rec.o/p range	0-10 vpm	0-5 vpm	0-10 vpm	0-10 vpm
Intrinsic error	<1% of reading or 0.5 vpm*	1% of reading or 0.1 vpm*	1% of reading or 0.5 vpm*	1% of reading or 0.5 vpm*
Linearity error	1% of reading or 0.5 vpm*	1% of reading or 0.1 vpm*	1% of reading or 0.5 vpm*	1% of reading or 0.5 vpm*
Repeatability	1% of reading or 0.5 vpm*	1% of reading or 0.1 vpm*	1% of reading or 0.5 vpm*	1% of reading or 0.5 vpm*
Response (T90)	<20sec at 2000ml/min			
Zero drift / week	1 vpm	0.2 vpm	1 vpm	1 vpm
Span drift / week	2% of reading or 1 vpm*	2% of reading or 0.2 vpm*	2% of reading or 1 vpm*	2% of reading or 1 vpm*
Output fluctuation (peak to peak)	1% of reading or 0.5 vpm*	1% of reading or 0.1 vpm*	1% of reading or 0.5 vpm*	1% of reading or 0.5 vpm*
Ambient pressure coefficient	0.25%	0.4%	0.5%	1%
	Of reading per 1% change in analyser vent pressure			
Ambient temp. coeff./ 10°C change	3% of reading or 1 vpm CO *	3% of reading or 0.25 vpm CO ₂ *	3% of reading or 1 vpm N ₂ O *	3% of reading or 1.5 vpm CH ₄ *
Inlet sample pressure effect from 2 to 8psig	<0.5 vpm CO	<0.25 vpm CO ₂	<1vpm N ₂ O for	<1.5% of reading or 0.5 vpm CH ₄ *
Sample flow effect range 1.5 to 2.5l/min	<1% of reading or 0.25 vpm CO*	<1% of reading or 0.25 vpm CO ₂ *	<1% of reading or 0.5 vpm N ₂ O*	<1.5% of reading or 0.5 vpm CH ₄ *

* whichever is the larger

Table 7.5: Gfx trace measurement cross sensitivity information			
Gfx 1210 CO	Gfx 1210 CO₂	Gfx 1210 N₂O	Gfx 1210 CH₄
2% H ₂ O ~ 0.5 vpm	no effects in target applications	500vpm CO ₂ ~ 0.5 vpm 10vpm CO ~ 0.5 vpm 2% H ₂ O ~ 0.5 vpm	1% O ₂ ~ 0.5 vpm 0.2% CO ~ 0.5 vpm 0.5% H ₂ O < 1 vpm

Table 7.6: 4100C performance specification, IR		
Gases measured	1520 CO₂	1522 CO
Range	see Table 7.7 below	
Min.rec.o/p range	80% of selected range	
Intrinsic error	1% of selected range	
Linearity error	1% of selected range	
Repeatability	1% of selected range	
Response (T90)	<20sec at 200ml/min	
Zero drift / week	2% of selected range	
Span drift / day	1% of selected range	
Output fluctuation (peak to peak)	0.5% of selected range or 1% of reading*	
Ambient pressure coefficient	0.2% of reading per mbar	
Ambient temp. coeff./10°C change	1% of selected range +/- <2.0% of reading	
Inlet sample pressure effect from 2 to 8psig	1.5% of selected range or <3% of reading*	
Sample flow effect range 50 to 200ml/min	1.5% of selected range or <3% of reading*	

* whichever is the larger

Table 7.7: 152X measurement ranges in 4100C									
Gases measured	Full scale measurement range %								
	0.25	0.5	1.0	2.5	5	10	25	50	100
1520 CO ₂	✓	✓	✓	✓	✓	✓	✓	✓	✓
1522 CO			✓	✓		✓			

7.4 4200C analyser performance

WARNING

This analyser (4202C and 4204C) is not suitable for use with hydrogen, acetylene or corrosive samples.

The auto-ignition temperature of each flammable gas in the sample must be greater than 135°C.

The maximum pressure to the analyser must be limited to 8psig by means of a suitable release system.

Sample requirements

For best performance the flow, or pressure, supplied to the analyser should be kept at a constant value for both normal sampling and for calibration gas input.

Temperature:	5 to 40°C / 41 to 104°F
Dew point	5°C / 9°F below minimum ambient
Condition:	Oil free, non - condensing, filtered to 2µm
Vent:	Each sensor outlet should be connected to a separate atmospheric vent, free from any back-pressure. (Consideration should be given to the toxicity, flammability and asphyxiant nature of the sample gas when selecting a vent location).
a) Flow driven options:	
	IR : 100 (min) - 250 (max) ml/min
	Pm Control: 100 (min) - 250 (max) ml/min
	Gfx: 500 (min) - 2.500 (max) ml/min
b) All pressure driven options:	
	nominal 5psig / 35kPa
	min. 2psig /14kPa, max. 8psig /56kPa

CAUTION

Do not exceed the rated flow or pressure as sensor damage may result.

Table 7.8: 4200C performance specification, oxygen and IR				
Gases measured	Pm1158 O₂ Control	1520 CO₂	1521 CH₄	1522 CO
Range	0-100%	see Table 7.9		
Min.rec.o/p range	0-5%	80% of selected range		
Intrinsic error	<0.15%	1% of selected range		
Linearity error	<0.05% inherently linear, dependant on cal. gases	1% of selected range		
Repeatability	<0.1%	1% of selected range		
Response (T90)	<15 sec at 200 ml/min	<20sec at 200ml/min		
Zero drift / week	0.05% O ₂	2% of selected range		
Span drift	0.1% O ₂ / week	1% of selected range/ day		
Output fluctuation (peak to peak)	<0.05% O ₂	0.5% of selected range or 1% of reading*		
Ambient pressure coefficient	directly proportional to analyser vent pressure	0.2% of reading per mbar		
Ambient temp. coeff./ 10°C change	1% of reading or 0.1% O ₂	1% of selected range +/- <2.0% of reading		
Inlet sample pressure effect from 2 to 8psig	<2% of reading or 0.1% O ₂ *	1.5% of selected range or <3% of reading*		
Sample flow effect over full flow range	<2% of reading or 0.1% O ₂ *	1.5% of selected range or <3% of reading*		

* whichever is the larger

Table 7.9: 152X measurement ranges in 4200C									
Gases measured	Full scale measurement range %								
	0.25	0.5	1.0	2.5	5	10	25	50	100
1520 CO ₂	✓	✓	✓	✓	✓	✓	✓	✓	✓
1521 CH ₄					✓		✓	✓	✓
1522 CO			✓	✓		✓	✓	✓	

Table 7.10: 4200C performance specification, Gfx				
Gases measured	Gfx 1210 CO Trace	Gfx 1210 CO₂ Trace	Gfx 1210 N₂O Trace	Gfx 1210 CH₄ Trace
Range (higher are available)	0-50 vpm	0-10 vpm	0-50 vpm	0-50 vpm
Min.rec.o/p range	0-10 vpm	0-5 vpm	0-10 vpm	0-10 vpm
Intrinsic error	1% of reading or 0.5 vpm*	1% of reading or 0.1 vpm*	1% of reading or 0.5 vpm*	1% of reading or 0.5 vpm*
Linearity error	1% of reading or 0.5 vpm*	1% of reading or 0.1 vpm*	1% of reading or 0.5 vpm*	1% of reading or 0.5 vpm*
Repeatability	1% of reading or 0.5 vpm*	1% of reading or 0.1 vpm*	1% of reading or 0.5 vpm*	1% of reading or 0.5 vpm*
Response (T90)	<20sec at 2000ml/min			
Zero drift / week	1vpm	0.2vpm	1vpm	1vpm
Span drift / week	2% of reading or 1 vpm*	2% of reading or 0.2 vpm*	2% of reading or 1 vpm*	2% of reading or 1 vpm*
Output fluctuation (peak to peak)	1% of reading or 0.5 vpm*	1% of reading or 0.1 vpm*	1% of reading or 0.5 vpm*	1% of reading or 0.5 vpm*
Ambient pressure coefficient	0.25%	0.4%	0.5%	1%
	Of reading per 1% change in analyser vent pressure			
Ambient temp. coeff./ 10°C change	3% of reading or 1 vpm CO *	3% of reading or 0.25 vpm CO ₂ *	3% of reading or 1 vpm N ₂ O *	3% of reading or 1.5 vpm CH ₄ *
Inlet sample pressure effect from 2 to 8psig	<0.5 vpm CO	<0.25 vpm CO ₂	<1 vpm N ₂ O for	<1.5% dof reading or 0.5 vpm CH ₄ *
Sample flow effect range 1.5 to 2.5l/min	<1% of reading or 0.25 vpm CO*	<1% of reading or 0.25 vpm CO ₂ *	<1% of reading or 0.5 vpm N ₂ O*	<1.5% of reading or 0.5 vpm CH ₄ *

* whichever is the larger

Table 7.11: Gfx trace measurement cross sensitivity information			
Gfx 1210 CO	Gfx 1210 CO₂	Gfx 1210 N₂O	Gfx 1210 CH₄
2% H ₂ O ~ 0.5 vpm	no effects in target applications	500vpm CO ₂ ~ 0.5 vpm 10vpm CO ~ 0.5 vpm 2% H ₂ O ~ 0.5 vpm	1% CO ₂ ~ 0.5 vpm 0.2% CO ~ 0.5 vpm 0.5% H ₂ O < 1 vpm

7.5 4210C analyser performance

WARNING

This analyser (4212C and 4214C) is not suitable for use with corrosive samples.

The auto-ignition temperature of each flammable gas in the sample must be greater than 135°C.

The maximum pressure to the analyser must be limited to 8psig by means of a suitable release system.

Sample requirements

For best performance the flow supplied to the analyser should be kept at a constant value for both normal sampling and for calibration gas input.

Temperature:	5 to 40°C / 41 to 104°F
Dew point	5°C / 9°F below minimum ambient
Condition:	Oil free, non - condensing, filtered to 2µm
Vent:	Each sensor outlet should be connected to a separate atmospheric vent, free from any back-pressure. (Consideration should be given to the toxicity, flammability and asphyxiant nature of the sample gas when selecting a vent location).
Flow driven options:	
IR :	100 (min) - 250 (max) ml/min
Pm Control:	100 (min) - 250 (max) ml/min
Gfx:	500 (min) - 2.500 (max) ml/min

Pressure driven options are not available.

CAUTION

Do not exceed the rated flow as sensor damage may result.

Table 7.12: 4210C performance specification, oxygen and IR				
Gases measured	Pm1158 O₂ Control	1520 CO₂	1521 CH₄	1522 CO
Range	0-100%	see Table 7.13		
Min.rec.o/p range	0-5%	80% of selected range		
Intrinsic error	<0.15%	1% of selected range		
Linearity error	<0.05% inherently linear, dependant on cal. gases	1% of selected range		
Repeatability	<0.1%	1% of selected range		
Response (T90)	<15 sec at 200ml/min	<20sec at 200ml/min		
Zero drift / week	0.05% O ₂	2% of selected range		
Span drift	0.1% O ₂ / week	1% of selected range/day		
Output fluctuation (peak to peak)	<0.05% O ₂	0.5% of selected range or 1% of reading*		
Ambient pressure coefficient	directly proportional to analyser vent pressure	0.2% of reading per mbar		
Ambient temp. coeff./ 10°C change	1% of reading or 0.1% O ₂	1% of selected range +/- <2.0% of reading		
Sample flow effect over full flow range	<2% of reading or 0.1% O ₂ *	1.5% of selected range or <3% of reading*		

* whichever is the larger

Table 7.13: 152X measurement ranges in 4210C									
Gases measured	Full scale measurement range %								
	0.25	0.5	1.0	2.5	5	10	25	50	100
1520 CO ₂	✓	✓	✓	✓	✓	✓	✓	✓	✓
1521 CH ₄					✓		✓	✓	✓
1522 CO			✓	✓		✓	✓	✓	

Table 7.14: 4210C performance specification, Gfx				
Gases measured	Gfx 1210 CO Trace	Gfx 1210 CO₂ Trace	Gfx 1210 N₂O Trace	Gfx 1210 CH₄ Trace
Range (higher are available)	0-50 vpm	0-10 vpm	0-50 vpm	0-50 vpm
Min.rec.o/p range	0-10 vpm	0-5 vpm	0-10 vpm	0-10 vpm
Intrinsic error	1% of reading or 0.5 vpm*	1% of reading or 0.1 vpm*	1% of reading or 0.5 vpm*	1% of reading or 0.5 vpm*
Linearity error	1% of reading or 0.5 vpm*	1% of reading or 0.1 vpm*	1% of reading or 0.5 vpm*	1% of reading or 0.5 vpm*
Repeatability	1% of reading or 0.5 vpm*	1% of reading or 0.1 vpm*	1% of reading or 0.5 vpm*	1% of reading or 0.5 vpm*
Response (T90)	<20sec at 2000ml/min			
Zero drift / week	1 vpm	0.2 vpm	1 vpm	1 vpm
Span drift / week	2% of reading or 1 vpm*	2% of reading or 0.2 vpm*	2% of reading or 1 vpm*	2% of reading or 1 vpm*
Output fluctuation (peak to peak)	1% of reading or 0.5 vpm*	1% of reading or 0.1 vpm*	1% of reading or 0.5 vpm*	1% of reading or 0.5 vpm*
Ambient pressure coefficient	0.25%	0.4%	0.5%	1%
	Of reading per 1% change in analyser vent pressure			
Ambient temp. coeff./ 10°C change	3% of reading or 1 vpm CO *	3% of reading or 0.25 vpm CO ₂ *	3% of reading or 1 vpm N ₂ O *	3% of reading or 1.5 vpm CH ₄ *
Sample flow effect range 1.5 to 2.5l/min	<1% of reading or 0.25 vpm CO*	<1% of reading or 0.25 vpm CO ₂ *	<1% of reading or 0.5 vpm N ₂ O*	<1.5% of reading or 0.5 vpm CH ₄ *

* whichever is the larger

Table 7.15: Gfx trace measurement cross sensitivity information			
Gfx 1210 CO	Gfx 1210 CO₂	Gfx 1210 N₂O	Gfx 1210 CH₄
2% H ₂ O ~ 0.5 vpm	no effects in target applications	500vpm CO ₂ ~ 0.5 vpm 10vpm CO ~ 0.5 vpm 2% H ₂ O ~ 0.5 vpm	1% CO ₂ ~ 0.5 vpm 0.2% CO ~ 0.5 vpm 0.5% H ₂ O < 1 vpm

7.6 4900C analyser performance

WARNING

This analyser (4902C and 4904C) is not suitable for use with flammable or corrosive samples.

If toxic samples are present, the maximum pressure to the analyser must be limited to 5psig by means of a suitable release system.

Sample requirements

For best performance the flow supplied to the analyser should be kept at a constant value for both normal sampling and for calibration gas input.

Temperature:	5 to 60°C / 41 to 140°F
Dew point:	5°C / 9°F below minimum ambient
Condition:	Oil free, non - condensing, filtered to 1µm
Vent:	Each gas outlet should be connected to a separate atmospheric vent, free from any back-pressure. (Consideration should be given to the toxicity and asphyxiant nature of the sample gas when selecting a vent location).
Inlet Flow:	500 (min) - 1500 (max) ml/min (for each stream)
Inlet Pressure:	Up to 1psig (7kPa) to provide specified flow rate.

CAUTION

Do not exceed the rated sample flow as sensor damage may result.

Do not exceed the sample temperature and dew point criteria as analyser sensor damage will result.

Table 7.16: 4900C performance specification, oxygen and IR				
Gases measured	Pm1111E O₂ Basic	Pm1158 O₂ Control	1520 CO₂	1522 CO
Range	0-25%	0-25%	see Table 7.5	
Min.rec.o/p range	0-5%	0-5%	80% of selected range	
Intrinsic error	<0.15%	<0.05%	1% of selected range	
Linearity error	<0.1%	<0.05%	1% of selected range	
	inherently linear, dependant on calibration gases			
Repeatability	<0.1%	<0.05% of reading or 0.01%*	1% of selected range	
Response (T90) at 1500ml/min	<15 sec	<15 sec	<30 sec	
Zero drift / week	0.1% O ₂	0.05% O ₂	2% of selected range	
Span drift	0.1% O ₂ / week	0.05% O ₂ / week	1% of selected range/ day	
Output fluctuation (peak to peak)	<0.1% O ₂	<0.01% O ₂	0.5% of selected range or 1% of reading*	
Ambient pressure coefficient	directly proportional to analyser vent pressure		0.2% of reading per mbar	
Ambient temp. coeff./ 10°C change	2% of reading or 0.5% O ₂	1% of reading or 0.1% O ₂ *	1% of selected range +/- <2.0% of reading	
Sample flow effect over full flow range	<2% of reading or 0.2% O ₂ *	<2% of reading or 0.1% O ₂ *	1.5% of selected range or <3% of reading*	

* whichever is the larger

Table 7.17: 152X measurement ranges in 4900C									
Gases measured	Full scale measurement range %								
	0.25	0.5	1.0	2.5	5	10	25	50	100
1520 CO ₂	✓	✓	✓	✓	✓	✓	✓	✓	✓
1522 CO			✓	✓		✓			

Table 7.18A: 4900C performance specification, Gfx				
Gases measured	Gfx 1210 SO₂ standard sensitivity	Gfx 1210 SO₂ high sensitivity	Gfx 1210 CO standard sensitivity	Gfx 1210 CO high sensitivity
Range	0-200 vpm † 0-2500 vpm	0-100 vpm 0-1000 vpm	0-200 vpm 0-3000 vpm	0-50 vpm 0-500 vpm
Min.rec.o/p range	0-200 vpm	0-100 vpm	0-200 vpm	0-50 vpm
Intrinsic error	1% of reading or 5 vpm*	1% of reading or 2 vpm*	1% of reading or 2 vpm*	1% of reading or 0.5 vpm*
Linearity error	1% of reading or 5 vpm*	1% of reading or 2 vpm*	1% of reading or 2 vpm*	1% of reading or 0.5 vpm*
Repeatability	1% of reading or 5 vpm*	1% of reading or 2 vpm*	1% of reading or 2 vpm*	1% of reading or 0.5 vpm*
Response (T90)	<30sec at 1500ml/min			
Zero drift / week	10 vpm	4 vpm	4 vpm	1 vpm
Span drift / week	2% of reading or 10 vpm*	2% of reading or 4 vpm*	2% of reading or 4 vpm*	2% of reading or 1 vpm*
Output fluctuation (peak to peak)	1% of reading or 5 vpm*	1% of reading or 2 vpm*	1% of reading or 2 vpm*	1% of reading or 0.5 vpm*
Ambient pressure coefficient	0.75%	0.65%	0.25%	0.25%
	Of reading per 1% change in analyser vent pressure			
Ambient temp. coeff./ 10°C change	3% of reading or 15 vpm *	3% of reading or 5 vpm *	3% of reading or 4 vpm *	3% of reading or 1 vpm *
Sample flow effect range 0.5 to 1.5l/min	<1% of reading or 5 vpm SO ₂ *	<1% of reading or 2 vpm SO ₂ *	<1% of reading or 2 vpm CO*	<1% of reading or 0.5 vpm CO*

* whichever is the larger

† TÜV validated range

Table 7.19A: 4900C measurement cross sensitivity information				
O₂	Gfx 1210 SO₂ 'Std'	Gfx 1210 SO₂ 'High'	Gfx 1210 CO 'Std'	Gfx 1210 CO 'High'
20% CO ₂ ~ 0.06%	20% CO ₂ ~ 5 vpm 0.5% H ₂ O ~ 15 vpm	20% CO ₂ ~ 2 vpm 0.5% H ₂ O ~ 15 vpm	20% CO ₂ ~ 2 vpm 2% H ₂ O ~ 0.5 vpm	20% CO ₂ ~ 1 vpm 2% H ₂ O ~ 0.5 vpm

Note: Normal sign of cross-interference is shown above, but effects can be positive or negative (same magnitude).

Table 7.18B: 4900C performance specification, Gfx			
Gases measured	Gfx 1210 N₂O Trace	Gfx 1210 NO Trace	Gfx 1210 CH₄ Trace
Range	0-50 vpm 0-500 vpm	0-100 vpm 0-1000 vpm	0-50 vpm 0-500 vpm
Min.rec.o/p range	0-10 vpm	0-100 vpm	0-10 vpm
Intrinsic error	1% of reading or 0.5 vpm*	1% of reading or 2 vpm*	1% of reading or 0.5 vpm*
Linearity error	1% of reading or 0.5 vpm*	1% of reading or 2 vpm*	1% of reading or 0.5 vpm*
Repeatability	1% of reading or 0.5 vpm*	1% of reading or 2 vpm*	1% of reading or 0.5 vpm*
Response (T90)	<30sec at 1500ml/min		
Zero drift / week	1vpm	2vpm	1vpm
Span drift / week	2% of reading or 1 vpm*	2% of reading or 2 vpm*	2% of reading or 1 vpm *
Output fluctuation (peak to peak)	1% of reading or 0.5 vpm*	1% of reading or 2 vpm*	1% of reading or 0.5 vpm*
Ambient pressure coefficient	0.5%	0.3%	1%
	Of reading per 1% change in analyser vent pressure		
Ambient temp. coeff./ 10°C change	3% of reading or 1 vpm N ₂ O *	3% of reading or 3 vpm *	3% of reading or 1.5 vpm CH ₄ *
Sample flow effect range 0.5 to 1.5l/min	<1% of reading or 0.5 vpm N ₂ O*	<1% of reading or 2 vpm NO*	<1.5% of reading or 0.5 vpm CH ₄ *

* whichever is the larger

Table 7.19B: 4900C measurement cross sensitivity information		
Gfx 1210 N₂O	Gfx 1210 NO	Gfx 1210 CH₄
500 vpm CO ₂ ~ 0.5 vpm	20% CO ₂ ~ 2 vpm	1% CO ₂ ~ 0.5 vpm
10 vpm CO ~ 0.5 vpm	0.5% H ₂ O ~ -2 vpm	0.2% CO ~ 0.5 vpm
2% H ₂ O ~ 0.5 vpm		0.5% H ₂ O <1 vpm

Note: Normal sign of cross-interference is shown above, but effects can be positive or negative (same magnitude)

APPENDIX A EFFECTS OF VARIATIONS IN SAMPLE COMPOSITION

Oxygen is a paramagnetic gas, i.e. it is attracted into a magnetic field. Virtually all other gases are diamagnetic, i.e. they are repelled by a magnetic field. Servomex oxygen analysers are calibrated on a scale which is normalised for nitrogen at 0 and oxygen at 100. For high accuracy measurements it may be necessary to introduce a zero offset into the calibration to compensate for the background gas. The Table below presents, for many common gases, the data required to calculate the zero offset.

For example, an analyser calibrated with nitrogen as the zero gas will, when 100% carbon dioxide is passed through it, give a reading of -0.30% oxygen. If it is required to measure oxygen in carbon dioxide then this will give an error. There are two ways to compensate for this:

1. CO₂ is used as the zero gas.
2. N₂ is used as the zero gas and the zero is offset to a value equal but opposite to the reading produced by the background gas.

In the example above this is -0.30% and the value +0.30 is entered as the gas zero instead of 0.00.

If the background gas is a mixture then the proportional sums of the zero offsets are used.

E.g. For a background gas with a composition of 12% CO₂, 5% CO, 5% n-Octane, 78% N₂, the zero offset will be:

12% CO ₂	= 12% of -0.30	=	-0.04
5% CO	= 5% of +0.07	=	+0.00
5% n-Octane	= 5% of -2.78	=	-0.14
78% N ₂	= 78% of 0.00	=	+0.00
	Total:	=	-0.18

(Where -0.30, +0.07 and -2.78 are the zero offsets of 100% carbon dioxide, carbon monoxide and n-octane respectively relative to pure nitrogen. See following table)

In this case gas zero should be set to +0.18.

Note 1 Nitrogen dioxide exists in equilibrium with dinitrogen tetroxide. The relative proportions vary greatly with temperature. As nitrogen dioxide is paramagnetic and dinitrogen tetroxide is diamagnetic, the relative molar susceptibility of the equilibrium gas also varies. The data given in the Table are for cell temperatures of either 60°C or 110°C. Neither of these temperatures may actually be the temperature of the process.

Note 2 Servomex Application Note AP01 lists the zero offsets for a range of technically important gases at cell temperatures of 60°C and 110°C.

Gas	Formula	Molar mag.susc $\times 10^{-6}$	Zero offset (x 0.01 %)			
			20°C	50°C	60°C	110°C
Acetaldehyde	CH ₂ CHO	-22.70	-0.31	-0.34	-0.35	-0.40
Acetic acid	CH ₃ CO ₂ H	-31.50	-0.56	-0.62	-0.64	-0.74
Acetone	CH ₃ COCH ₃	-33.70	-0.63	-0.69	-0.71	-0.82
Acetylene	HCCH	-20.80	-0.25	-0.28	-0.29	-0.33
Acrylonitrile	CH ₂ =CHCN	-24.10	-0.35	-0.39	-0.40	-0.46
Allyl alcohol	CH ₂ CHCH ₂ OH	-36.70	-0.71	-0.79	-0.81	-0.93
Ammonia	NH ₃	-18.00	-0.17	-0.19	-0.20	-0.23
Argon	Ar	-19.60	-0.22	-0.24	-0.25	-0.29
Benzene	C ₆ H ₆	-54.84	-1.24	-1.36	-1.41	-1.62
Boron chloride	BCl ₃	-59.90	-1.38	-1.53	-1.57	-1.81
Boron trifluoride	BF ₃	-19.00	-0.20	-0.22	-0.23	-0.26
Bromine	Br ₂	-73.50	-1.78	-1.96	-2.02	-2.32
1,2 Butadiene	C ₄ H ₆	-35.60	-0.68	-0.75	-0.77	-0.89
1,3 Butadiene	C ₄ H ₆	-30.60	-0.54	-0.59	-0.61	-0.70
n-Butane	C ₄ H ₁₀	-50.30	-1.11	-1.22	-1.26	-1.45
iso-Butane	(CH ₃) ₂ CHCH ₂	-51.70	-1.15	-1.26	-1.30	-1.50
1 Butene	CH ₃ CH ₂ CH=CH ₂	-41.10	-0.84	-0.93	-0.96	-1.10
n-Butyl acetate	CH ₃ COOC ₄ H ₉	-77.50	-1.89	-2.09	-2.15	-2.47
iso-Butylene	(CH ₃) ₂ CH=CH ₂	-44.40	-0.94	-1.03	-1.06	-1.22
1 Butyne (Ethyacetylene)	CH ₃ C ₃ H ₂	-43.50	-0.91	-1.00	-1.03	-1.19
Carbon dioxide	CO ₂	-21.00	-0.26	-0.29	-0.30	-0.34
Carbon disulphide	CS ₂	-42.20	-0.87	-0.96	-0.99	-1.14
Carbon monoxide	CO	-9.80	0.06	0.07	0.07	0.08
Carbon tetrachloride	CCl ₄	-66.60	-1.58	-1.74	-1.79	-2.06
Carbon tetrafluoride	CF ₄	-31.20	-0.55	-0.61	-0.63	-0.72
Chlorine	Cl ₂	-40.50	-0.82	-0.91	-0.94	-1.08
Chloro ethanol	ClCH ₂ CH ₂ OH	-51.40	-1.14	-1.25	-1.29	-1.49
Chloroform	CHCl ₃	-59.30	-1.37	-1.51	-1.55	-1.78
Cumene	(CH ₃) ₂ CHC ₆ H ₅	-89.53	-2.24	-2.47	-2.55	-2.93
Cyclohexane	C ₆ H ₁₂	-68.13	-1.62	-1.79	-1.84	-2.12
Cyclopentane	C ₅ H ₁₀	-59.18	-1.36	-1.50	-1.55	-1.70
Cyclopropane	C ₃ H ₆	-39.90	-0.81	-0.89	-0.92	-1.05
Diacetylene	C ₄ H ₂	-37.50	-0.74	-0.81	-0.84	-0.96
Dichloroethylene	(CHCl) ₂	-49.20	-1.07	-1.18	-1.22	-1.40
Diethyl ether	(C ₂ H ₅) ₂ O	-55.10	-1.25	-1.37	-1.41	-1.63
2,2 Difluoro 1 chloroethane	CClH ₂ CHF ₂	-52.40	-1.17	-1.29	-1.33	-1.52
1,2 Difluoro 1,2 dichloroethylene	CFCl=CFCl	-60.00	-1.39	-1.53	-1.58	-1.81
Difluoro dichloro methane (Freon 12)	CCl ₂ F ₂	-52.20	-1.16	-1.28	-1.32	-1.5
Dimethoxy methane	CH ₂ (OCH ₃) ₂	-47.30	-1.02	-1.12	-1.16	-1.33
Dimethylamine	(CH ₃) ₂ NH	-39.90	-0.81	-0.89	-0.92	-1.05
Dimethylether	CH ₃ OCH ₃	-26.30	-0.41	-0.46	-0.47	-0.54
Dimethylethylamine	(CH ₃) ₂ NC ₂ H ₅	-63.60	-1.49	-1.64	-1.69	-1.95
Enflurane (Ethrane)	C ₃ H ₂ F ₅ ClO	-80.10	-1.97	-2.17	-2.24	-2.57
Ethane	C ₂ H ₆	-26.80	-0.43	-0.47	-0.49	-0.56
Ethanol	C ₂ H ₅ OH	-33.60	-0.62	-0.69	-0.71	-0.82
Ethyl acetate	CH ₃ COOC ₂ H ₅	-54.20	-1.22	-1.34	-1.39	-1.59
Ethyl amine	C ₂ H ₅ NH ₂	-39.90	-0.81	-0.89	-0.92	-1.05
Ethyl benzene	C ₆ H ₅ C ₂ H ₅	-77.20	-1.88	-2.08	-2.14	-2.46
Ethyl bromide	C ₂ H ₅ Br	-54.70	-1.23	-1.36	-1.40	-1.61
Ethyl chloride	C ₂ H ₅ Cl	-46.00	-0.98	-1.08	-1.12	-1.28
Ethylene	C ₂ H ₄	-18.80	-0.20	-0.22	-0.22	-0.26
Ethylene glycol	(CH ₂ OH) ₂	-38.80	-0.77	-0.85	-0.88	-1.01
Ethylene oxide	(CH ₂) ₂ O	-30.70	-0.54	-0.60	-0.61	-0.71
Ethyl mercaptan	C ₂ H ₅ OSO ₃ H	-47.00	-1.01	-1.11	-1.15	-1.32

Gas	Formula	Molar mag.susc x 10 ⁻⁶	Zero offset (x 0.01 %)			
			20°C	50°C	60°C	110°C
Fluorochlorobromomethane	CFCIBr	-58.00	-1.33	-1.46	-1.51	-1.74
Fluorodichloromethane (Freon 21)	CHCl ₂ F	-48.80	-1.06	-1.17	-1.21	-1.39
Fluorene	CF ₃ CH ₂ OCHCH ₂	-56.70	-1.29	-1.42	-1.47	-1.69
Freon 114	C ₂ Cl ₂ F ₄	-77.40	-1.89	-2.08	-2.15	-2.47
Furan	C ₄ H ₄ O	-43.09	-0.90	-0.99	-1.02	-1.17
Germanium tetrachloride	GeCl ₄	-72.00	-1.73	-1.91	-1.97	-2.26
Halothane	C ₂ HBrClF ₃	-78.80	-1.93	-2.13	-2.19	-2.52
Helium	He	-1.88	0.29	0.32	0.33	0.38
n-Heptane	C ₇ H ₁₆	-85.24	-2.12	-2.33	-2.40	-2.76
n-Hexane	C ₆ H ₁₄	-73.60	-1.78	-1.96	-2.02	-2.32
Hydrogen	H ₂	-3.98	0.23	0.26	0.26	0.30
Hydrogen bromide	HBr	-35.30	-0.67	-0.74	-0.76	-0.88
Hydrogen chloride	HCl	-22.60	-0.31	-0.34	-0.35	-0.40
Hydrogen cyanide	HCN	-14.50	-0.07	-0.08	-0.08	-0.09
Hydrogen iodide	HI	-48.20	-1.05	-1.15	-1.19	-1.37
Hydrogen selenide	H ₂ Se	-39.20	-0.79	-0.87	-0.89	-1.03
Hydrogen sulphide	H ₂ S	-25.50	-0.39	-0.43	-0.44	-0.51
Isoflurane (Forane)	C ₃ H ₂ F ₅ ClO	-80.10	-1.97	-2.17	-2.24	-2.57
Isoprene	C ₅ H ₈	-44.80	-0.95	-1.04	-1.08	-1.24
Ketene	CH ₂ CO	-15.70	-0.11	-0.12	-0.12	-0.14
Krypton	Kr	-28.80	-0.49	-0.54	-0.55	-0.63
Methane	CH ₄	-17.40	-0.16	-0.17	-0.18	-0.20
Methanol	CH ₃ OH	-21.40	-0.27	-0.30	-0.31	-0.35
Methoxyfluorane	CHCl ₂ CF ₂ OCH ₃	-87.10	-2.17	-2.39	-2.47	-2.83
Methyl acetate	CH ₃ COCH ₃	-42.60	-0.88	-0.97	-1.00	-1.15
Methyl cyclopentane	C ₆ H ₁₂	-70.20	-1.68	-1.85	-1.91	-2.20
Methylene chloride	CH ₂ Cl ₂	-46.60	-1.00	-1.10	-1.14	-1.31
Methylethylketone	CH ₃ COCH ₂ CH ₃	-45.50	-0.97	-1.07	-1.10	-1.26
Methyl fluoride	CH ₃ F	-25.50	-0.39	-0.43	-0.44	-0.51
Methyl formate	HCOOCH ₃	-32.00	-0.58	-0.64	-0.66	-0.75
Methyl iodide	CH ₃ I	-57.20	-1.31	-1.44	-1.48	-1.71
Methyl iso-butyl ketone (MIBK)	C ₄ H ₉ COCH ₃	-69.30	-1.66	-1.82	-1.88	-2.16
Methyl mercaptan	CH ₃ SH	-35.30	-0.67	-0.74	-0.76	-0.88
Molybdenum hexafluoride	MoF ₆	-26.00	-0.40	-0.45	-0.46	-0.53
Monochlorobenzene	C ₆ H ₅ Cl	-70.00	-1.68	-1.85	-1.90	-2.19
Neon	Ne	-6.70	0.15	0.17	0.17	0.20
Nitric oxide	NO	1461.00	42.56	42.96	42.94	41.62
Nitrobenzene	C ₆ H ₅ NO ₂	-61.80	-1.44	-1.59	-1.63	-1.88
Nitrogen	N ₂	-12.00	0.00	0.00	0.00	0.00
Nitrogen dioxide	NO ₂	150.00	5.00	16.00	20.00	35.00
ortho-Nitrotoluene	C ₆ H ₄ CH ₃ NO ₂	-72.30	-1.74	-1.92	-1.98	-2.28
para-Nitrotoluene	C ₆ H ₄ CH ₃ NO ₂	-76.90	-1.88	-2.07	-2.13	-2.45
Nitrous oxide	N ₂ O	-18.90	-0.20	-0.22	-0.23	-0.26
n-Nonane	C ₉ H ₂₀	-108.13	-2.78	-3.06	-3.16	-3.63
n-Octane	C ₈ H ₁₈	-96.63	-2.45	-2.70	-2.78	-3.19
Oxygen	O ₂	3449.00	100.0	100.0	100.0	100.0
Ozone	O ₃	6.70	0.54	0.60	0.61	0.71
iso-Pentane	C ₅ H ₁₂	-64.40	-1.51	-1.67	-1.72	-1.98
n-Pentane	C ₅ H ₁₂	-63.10	-1.48	-1.63	-1.68	-1.93
0.01%Phenol	C ₆ H ₅ OH	-60.21	-1.39	-1.54	-1.58	-1.82
Phosphine	PH ₃	-26.00	-0.40	-0.45	-0.46	-0.53

Gas	Formula	Molar mag.susc $\times 10^{-6}$	Zero offset (x 0.01 %)			
			20°C	50°C	60°C	110°C
Phosphorous oxychloride	POCl_3	-69.00	-1.65	-1.82	-1.87	-2.15
Propane	C_3H_8	-38.60	-0.77	-0.85	-0.87	-1.00
iso-Propanol	$(\text{CH}_3)_2\text{CHOH}$	-47.60	-1.03	-1.13	-1.17	-1.34
Propene	$\text{CH}_3\text{CH}=\text{CH}_2$	-31.50	-0.56	-0.62	-0.64	-0.74
n-Propyl acetate	$\text{CH}_3\text{COOC}_3\text{H}_7$	-65.90	-1.56	-1.72	-1.77	-2.03
Propyl amine	$\text{C}_3\text{H}_7\text{NH}_2$	-52.40	-1.17	-1.29	-1.33	-1.52
Propyl chloride	$\text{C}_3\text{H}_7\text{Cl}$	-56.10	-1.27	-1.40	-1.45	-1.66
Propylene	C_3H_6	-31.50	-0.56	-0.62	-0.64	-0.74
Propylene oxide	$\text{OCH}_2\text{CHCH}_3$	-42.50	-0.88	-0.97	-1.00	-1.15
iso-Propyl ether	$(\text{CH}_3)_4\text{CHOCH}$	-79.40	-1.95	-2.15	-2.21	-2.54
Propyl fluoride	$\text{C}_3\text{H}_7\text{F}$	-52.20	-1.16	-1.28	-1.32	-1.52
Pyridine	$\text{N}(\text{CH})_5$	-49.21	-1.08	-1.19	-1.22	-1.40
Silane	SiH_4	-20.50	-0.25	-0.27	-0.28	-0.32
Silicon tetrachloride	SiCl_4	-88.30	-2.20	-2.43	-2.50	-2.88
Styrene	$\text{C}_6\text{H}_5\text{CH}=\text{CH}_2$	-68.20	-1.62	-1.79	-1.85	-2.12
Sulphur dioxide	SO_2	-18.20	-0.18	-0.20	-0.20	-0.23
Sulphur hexafluoride	SF_6	-44.00	-0.92	-1.02	-1.05	-1.21
Tetrachoroethylene	$\text{Cl}_2\text{C}=\text{CCl}_2$	-81.60	-2.01	-2.22	-2.28	-2.63
Tetrahydrofuran	$\text{C}_4\text{H}_8\text{O}$	-52.00	-1.16	-1.27	-1.31	-1.51
Toluene	$\text{C}_6\text{H}_5\text{CH}_3$	-66.11	-1.56	-1.72	-1.78	-2.04
1,1,2 Trichloroethane (Freon 113)	$\text{CHCl}_2\text{CH}_2\text{Cl}$	-66.20	-1.57	-1.73	-1.78	-2.05
Trichloroethylene	$\text{CHCl}=\text{CCl}_2$	-65.80	-1.55	-1.71	-1.77	-2.03
Trifluorochloroethylene	$\text{C}_2\text{F}_3\text{Cl}$	-49.10	-1.07	-1.18	-1.22	-1.40
Trimethylamine	$(\text{CH}_3)_3\text{N}$	-51.70	-1.15	-1.26	-1.30	-1.50
Tungsten fluoride	WF_6	-40.00	-0.81	-0.89	-0.92	-1.06
Urethane	$\text{CO}(\text{NH}_2)\text{OC}_2\text{H}_5$	-57.00	-1.30	-1.43	-1.48	-1.70
Vacuum	-	0.00	0.35	0.38	0.39	0.45
Vinyl bromide	$\text{CH}_2=\text{CHBr}$	-44.80	-0.95	-1.04	-1.08	-1.24
Vinyl chloride	$\text{CH}_2=\text{CHCl}$	-35.60	-0.68	-0.75	-0.77	-0.89
Vinyl fluoride	$\text{CH}_2=\text{CHF}$	-28.80	-0.49	-0.54	-0.55	-0.63
Water	H_2O	-13.00	-0.03	-0.03	-0.03	-0.04
Xenon	Xe	-43.90	-0.92	-1.02	-1.05	-1.20
Xylene	$(\text{CH}_3)_2\text{C}_6\text{H}_4$	-77.78	-1.90	-2.09	-2.16	-2.48

APPENDIX B MODBUS PROFILE

The analyser supports Modbus slave communication through the serial data connector (PL6). This supports an RS232 or RS485 multidrop link to a Modbus master. The implementation of Modbus is based on the "Modicon Modbus Protocol Reference Guide PI-MBUS-300 Rev. J" dated June 1996.

The following facilities are provided:

- Access to measurement data
- Access to derived measurement data
- Access to external analogue input data
- Access to measurement status and alarm information
- Access to analyser status information
- Initiation of individual autocalibration groups
- Progress indication of autocalibration
- Ability to stop current autocalibrations
- Diagnostic and error functions

These are described below.

NOTE	
Measurement data is in IEEE 754 floating point format. Each value requires 2 registers as follows:	
Register N	= High word
Register N + 1	= Low word

Measurement data

Measurement data from each of the four possible transducer positions is available in a block of input registers that can be read using Modbus function code 04.

Registers	Name	Comments
30001 – 30002	I1 Measurement	Measurement 1 value in IEEE 754 floating point format
30003 – 30005	I1 Name	A 6 character string containing the measurement 1 name
30006 – 30007	I1 Units	A 3 character string containing the measurement 1 units

30008 – 30009	I2 Measurement	Measurement 2 value in IEEE 754 floating point format
30010 – 30012	I2 Name	A 6 character string containing the measurement 2 name
30013 – 30014	I2 Units	A 3 character string containing the measurement 2 units

30015 – 30016	I3 Measurement	Measurement 3 value in IEEE 754 floating point format
30017 – 30019	I3 Name	A 6 character string containing the measurement 3 name
30020 – 30021	I3 Units	A 3 character string containing the measurement 3 units

30022 – 30023	I4 Measurement	Measurement 4 value in IEEE 754 floating point format
30024 – 30026	I4 Name	A 6 character string containing the measurement 4 name
30027 – 30028	I4 Units	A 3 character string containing the measurement 4 units

Derived measurement data

Derived measurement data associated with each of the four possible transducer positions is available in a block of input registers that can be read using Modbus function code 04.

Registers	Name	Comments
30029 - 30030	D1 Measurement	Derived measurement 1 value in IEEE 754 floating point format
30031 - 30033	D1 Name	A 6 character string containing the derived measurement 1 name
30034 - 30035	D1 Units	A 3 character string containing the derived measurement 1 units

30036 - 30037	D2 Measurement	Derived measurement 2 value in IEEE 754 floating point format
30038 - 30040	D2 Name	A 6 character string containing the derived measurement 2 name
30041 - 30042	D2 Units	A 3 character string containing the derived measurement 2 units

30043 - 30044	D3 Measurement	Derived measurement 3 value in IEEE 754 floating point format
30045 - 30047	D3 Name	A 6 character string containing the derived measurement 3 name
30048 - 30049	D3 Units	A 3 character string containing the derived measurement 3 units

30050 - 30051	D4 Measurement	Derived measurement 4 value in IEEE 754 floating point format
30052 - 30054	D4 Name	A 6 character string containing the derived measurement 4 name
30055 - 30056	D4 Units	A 3 character string containing the derived measurement 4 units

Analogue input data

Analogue input data from the two external mA inputs is available in a block of input registers that can be read using Modbus function code 04.

Registers	Name	Comments
30057 – 30058	E1 Measurement	External mA input 1 value in IEEE 754 floating point format
30059 – 30061	E1 Name	A 6 character string containing the external mA input 1 name
30062 – 30063	E1 Units	A 3 character string containing the external mA input 1 units

30064 – 30065	E2 Measurement	External mA input 2 value in IEEE 754 floating point format
30066 – 30068	E2 Name	A 6 character string containing the external mA input 2 name
30069 – 30070	E2 Units	A 3 character string containing the external mA input 2 units

Status and alarm information

Read-only access to measurement status and alarm information is provided in a block of discrete inputs that can be read with function code 02.

Discrete Input	Description	+ Offset							
		0	1	2	3	4	5	6	7
10001	Measurement I1	Fault	Maintenance	Calibration	Warming up	Alarm 1	Alarm 2	Alarm 3	Alarm 4
10009	Measurement I2	Fault	Maintenance	Calibration	Warming up	Alarm 1	Alarm 2	Alarm 3	Alarm 4
10017	Measurement I3	Fault	Maintenance	Calibration	Warming up	Alarm 1	Alarm 2	Alarm 3	Alarm 4
10025	Measurement I4	Fault	Maintenance	Calibration	Warming up	Alarm 1	Alarm 2	Alarm 3	Alarm 4
10033	Derived D1	Fault *	Maintenance *	Calibration *	Warming up *	Alarm 1	Alarm 2	Alarm 3	Alarm 4
10041	Derived D2	Fault *	Maintenance *	Calibration *	Warming up *	Alarm 1	Alarm 2	Alarm 3	Alarm 4
10049	Derived D3	Fault *	Maintenance *	Calibration *	Warming up *	Alarm 1	Alarm 2	Alarm 3	Alarm 4
10057	Derived D4	Fault *	Maintenance *	Calibration *	Warming up *	Alarm 1	Alarm 2	Alarm 3	Alarm 4
10065	External mA 1	Invalid	0	0	0	Alarm 1	Alarm 2	Alarm 3	Alarm 4
10073	External mA 2	Invalid	0	0	0	Alarm 1	Alarm 2	Alarm 3	Alarm 4

* Note that derived measurement status flags are copies of corresponding primary measurement status flags.

In the above table, the Modbus “address” of an individual flag may be calculated by adding the appropriate offset to the discrete input value. For example, the Modbus address of the Calibration flag on Measurement I4 is $10025 + 2 = 10027$.

Analyser status and autocalibration progress

Read-only access to analyser status and autocalibration information is provided in a separate block of discrete inputs that can be read with function code 02.

Discrete Input	Description	Comments											
11001	Analyser Fault flag												
11002	Analyser Maintenance flag												
11003 – 11008	Not assigned	These inputs return 0											
11009	Group 1 Sample/Cal	For each calibration group, the Sample/Cal and Cal1/Cal2 flags indicate the required solenoid valve state: <table border="1" style="margin-left: 20px;"> <thead> <tr> <th rowspan="2">Status State</th> <th colspan="2">Status Flag</th> </tr> <tr> <th>Sample/Cal</th> <th>Cal1/Cal2</th> </tr> </thead> <tbody> <tr> <td>0</td> <td>Sample gas</td> <td>Cal gas 1</td> </tr> <tr> <td>1</td> <td>Calibration gas</td> <td>Cal gas 2</td> </tr> </tbody> </table>	Status State	Status Flag		Sample/Cal	Cal1/Cal2	0	Sample gas	Cal gas 1	1	Calibration gas	Cal gas 2
Status State	Status Flag												
	Sample/Cal		Cal1/Cal2										
0	Sample gas		Cal gas 1										
1	Calibration gas		Cal gas 2										
11010	Group 1 Cal1/Cal2												
11011	Group 2 Sample/Cal												
11012	Group 2 Cal1/Cal2												
11013	Group 3 Sample/Cal												
11014	Group 3 Cal1/Cal2												
11015	Group 4 Sample/Cal												
11016	Group 4 Cal1/Cal2												

Starting/stopping autocalibration

Using the following block of coils, an autocalibration on a specific calibration group may be started, or all calibrations may be stopped.

Coil	Description
00001	Start Calibration Group 1
00002	Start Calibration Group 2
00003	Start Calibration Group 3
00004	Start Calibration Group 4

00009	Stop all autocalibrations (however initiated)
-------	---

The action will be requested when a coil state is changed from a **0** to a **1**. This request is treated in the same way and subject to the same rules as a request initiated from the keypad. The Modbus master is responsible for subsequently returning the state to **0**.

Coil states may be written using function codes 05 or 15. If desired, their current state may be read back with function code 01.

Diagnostic functions

Modbus function code 08 provides a diagnostic capability for checking communication between the master and the analyser. Following the function code is a 2-byte sub function code that specifies the test to be performed, followed by data.

This implementation only supports sub function code 00 which causes the data passed in the query field to be looped back.

Exception codes

If a communications error (e.g. framing error, checksum error) is detected during the receipt of a Modbus message, that message is ignored and no response is generated.

All correctly received Modbus messages are checked for a valid function code and data address. If a problem is detected the following exception responses are returned.

Where a request to write a coil state is received, the data field is validated against the Modbus standard. Invalid data is rejected and results in an exception response.

The exception codes are as follows:

Condition	Exception Code
Requested function code is not supported	01
Register or coil address outside of supported range	02
Invalid data	03