

OWNER'S MANUAL

US

Permobil C500

Power Wheelchair



How to contact Permobil

Permobil Inc. USA

6961 Eastgate Blvd.
Lebanon, TN 37090
USA

Phone: 800-736-0925

Fax: 800-231-3256

Email: info@permobilusa.com

Head Office of the Permobil group

Permobil AB

Box 120
861 23 Timrå
Sweden

Tel: +46 60 59 59 00

Fax: +46 60 57 52 50

E-mail: info@permobil.se

Permobil C500

Power Wheelchair

Produced and published by Permobil AB, Sweden
Version no.: 4 - 2009-05
Art. no.: 205226-US-0

Important information about the owner’s manual	6
General information.....	7
Technical support.....	7
Spare parts & accessories	7
Disposal.....	7
Warranty & service	7
Product approval	7
Safety rules.....	8-23
Design & function	24
General - overview	24
Seat lift - seat angle.....	25
Driving - shock absorbers	26
Wheels, lights, reflectors	27
Electronics - batteries	28
Electronics - fuses.....	29
R-Net control panel - design and function	30-39
Operation.....	40
General - driving	40
Driving technique	42
Seat functions	44
Driving rules	48
Manual brake release	53
Charging batteries	54
Transport.....	56
Air transport.....	58
Maintenance and repairs.....	60
Toolbag	60
General - batteries, storage	61
Cleaning	62
Replacing the batteries	64
Fuses	68
Technical specifications.....	70
Data - electrical system.....	71
Troubleshooting guide.....	72
R-net diagnostics.....	74
Accessories	76
Important Information about Electromagnetic Interference (EMI)	77-78

Important Information about this Owner's Manual

We congratulate you on your choice of power wheelchair. Our goal is for you to continue to feel satisfied with your choice of both vendor and wheelchair.

Before you begin using your wheelchair, it is important that you read and understand the content of these operating instructions and in particular the Safety Instructions.

These operating instructions are primarily intended to acquaint you with the functions and characteristics of the wheelchair and how you can use them in the best manner possible. They also contain important safety and maintenance information, as well as describing possible problems that can arise while driving the wheelchair.

Always keep these operating instructions handy in connection with your wheelchair, since the need for important information can arise concerning its use, safety and maintenance.

It is also possible to obtain information concerning our products from our home page on the Internet. You can find us at www.permobil.com.

All information, pictures, illustrations and specifications are based upon the product information that was available at the time that these operating instructions were printed. Pictures and illustrations that are found in these operating instructions are representative examples and not intended to be exact depictions of the various parts of the wheelchair.

We reserve the right to make changes to the product without prior notice.

Ordering of Documentation

If you are in need of another copy of the Owner's Manual, it can be ordered from Permobil, ask for item No. 205226-US-0.

TECHNICAL SUPPORT

In the event of technical problems, you should contact your dealer or Permobil Inc USA at 1-800-736-0925.

Always state the chassis serial number when contacting Permobil to ensure that the correct information is provided.

SPARE PARTS & ACCESSORIES

Spare parts and accessories must be ordered through your dealer.

SCRAPPING THE WHEELCHAIR

Contact Permobil Inc. for information about scrapping agreements in force.

WARRANTY

A warranty registration card is attached to each new wheelchair. The Permobil Inc. Product Warranty Information sets forth the conditions of the warranty.

Contact your dealer or Permobil Inc USA for information about the warranty period for this wheelchair.

Safety Instructions - General

A power wheelchair is a motorized vehicle and special care must therefore be taken when it is used. Please read and follow all instructions and warnings in this manual before operating your Permobil powered wheelchair. Incorrect use may both injure the user and damage the chair. In order to reduce these risks, you should read the Owner's Manual carefully, in particular the safety instructions and their warning texts.

Throughout this manual the following symbol will be used to note items that have significant importance to safety concerns:



NOTE

Please use caution where this symbol appears.



WARNING

Please use extreme caution where this warning symbol appears. Failure to observe warnings can lead to personal injury and property damage, including damage to the wheelchair.

Permobil is not responsible for personal injuries or property damage resulting from any person's failure to follow the warnings and instructions in this manual. Permobil is not responsible for injuries or damage resulting from failure to exercise good judgment.

The final selection and purchasing decision about the type of power wheelchair to be used is the responsibility of the wheelchair user and his or her healthcare professional. Permobil Inc. is not responsible for inappropriate selections of wheelchair models or features or improper fitting of the wheelchair.

Safety Instructions - General

Your wheelchair was configured specifically for your needs as prescribed by your healthcare provider. Consult your healthcare provider before changing the seat position or making any other adjustment. Some adjustments may reduce your wheelchair's performance or safety or may not be appropriate for your needs.

It is also of the utmost importance that you devote sufficient time to become acquainted with the different buttons, the function and steering controls, the different adjustment possibilities of the seat, etc. of your wheelchair and its accessories before you begin using it.

Do not undertake your own first test drive without making sure that you have assistance in the immediate vicinity if you should need help.

In order to make sure that nothing happened to the wheelchair while it was being shipped to you, you should check the following items before beginning to use it:

- that all products ordered are included in the delivery, including operating instructions and possible other documentation. If you suspect that something is missing, then contact your supplier or Permobil for more information as soon as possible.
- that no transport-related or other damages have occurred to the wheelchair and its accessories. If you discover that something has been damaged or in some other manner appears to be incorrect, then contact your supplier or Permobil for more information as soon as possible before you continue the checks.

We recommend that you charge your wheelchair's batteries before you begin using it. The chapter titled "Charging the Batteries" describes how to do this.

Always be sure that tires are inflated properly before driving.

If you experience that the wheelchair in any manner is not behaving as expected or if you suspect that something is wrong: abort the test drive as soon as possible, shut off the wheelchair and get in touch with your service contact or Permobil for more information.

Safety Instructions



WARNING

Operation

Permobil recommends the use of wheelchair lights at all times user is riding near public rights of way. Use extreme caution when driving near unprotected ledges, drop-offs or on elevated surfaces. Unintended movement or excessive speed in these areas can lead to personal injury or property damage.

Do not drive the wheelchair over any curbs or edges higher than 3 inches. When driving over a curb or similarly elevated surface, you must cross the surface at a 90 degree angle (perpendicular). Crossing such surfaces at any other angle may result in the wheelchair tipping.

Reduce your speed when driving on uneven terrain or soft surfaces. Do not use your wheelchair on stairs or escalators. Always use an elevator.

Do not lift or move the wheelchair by any of its removable parts. Doing so could lead to personal injury and property damage, including damage to the wheelchair.



NOTE

Operation

Do not let children drive the wheelchair without supervision. Do not drive the wheelchair on public streets or roadways. Obey all local pedestrian rules and be aware that vehicle drivers may have difficulty seeing you.

Do not operate your wheelchair under the influence of alcohol. Consumption of alcohol may impair your ability to operate your wheelchair safely.

Some physical limitations or use of medication, either prescribed or over-the-counter, may limit your ability to operate your wheelchair safely. Be sure to consult with your physician about your physical limitations and medications.

Safety Instructions



WARNING

Modifications

Any unauthorized modifications to the wheelchair or its various systems may increase the risk of personal injury and property damage, including damage to the wheelchair.

All modifications to and interventions in the vital systems of the wheelchair must be performed by a qualified service technician authorized by Permobil to perform such service on Permobil products.

Weight Limitations

The maximum user weight for your Permobil is set forth in the specification section of the supplied Owner's Manual for current seat model. Operation of the wheelchair by users who exceed the maximum allowable user weight can lead to personal injury and property damage, including damage to the wheelchair, as well as voiding any applicable warranty to the wheelchair.

Do not carry passengers on the wheelchair. Doing so can lead to personal injury and property damage, including damage to the wheelchair.



NOTE

Prior to Riding

In some instances, including where certain medical conditions exist, users should practice operating their wheelchair under the supervision of an assistant who is familiar with the operation of the wheelchair and with the abilities and limitations of the user.

Safety Instructions



NOTE

Operation - Inclines

When driving downhill, select the slowest speed and proceed with caution. Driving down an incline in a front wheel drive wheelchair can shift the user's center of gravity forward. If the wheelchair rolls faster than you would like, stop the wheelchair by releasing the joystick and begin descending again at a slower speed.

Avoid sudden stops or starts. Stop by releasing joystick rather than by turning the power off. Turning off power while the wheelchair is in motion will cause the wheelchair to stop suddenly. Be sure to keep all recommended positioning belts securely fastened at all times.

When driving up an incline, try to keep moving at a steady speed. Stopping and starting the chair while moving up an incline makes the wheelchair more difficult to control.

Do not drive up or down slopes with a gradient greater than indicated in the technical specifications section of the manual. There is a risk that the wheelchair will not maneuver safely.

Safety Instructions



WARNING

Operation - Inclines

Do not drive the wheelchair where the sideways gradient is more than indicated in the technical specifications section of the manual. There is a risk of tipping over.

Do not drive up or down ramps that are not equipped with proper edge protection along the sides of the ramp to prevent the wheelchair from falling off of the ramp.

When driving up an incline, be sure to drive your wheelchair straight up the incline (perpendicular). Driving at an angle up an incline increases the risk of tipping or falling. Use extreme caution when driving up an incline.

Do not drive down or up a hazardous incline, such as a surface covered with snow, ice, or wet leaves or a surface that is uneven. Also avoid driving on ramps that do not have proper edge protection.

Safety Instructions



WARNING

Operation - Turning

Turning your wheelchair at high speeds can create the possibility of the wheelchair tipping and personal injury. The possibility of tipping can be increased by high turning speed, sharp turns, uneven surfaces, abrupt changes in direction, and driving from an area of low traction (e.g. lawn) to an area of high traction (e.g. sidewalk).

To protect against tipping, personal injury and property damage, reduce speed and reduce the sharpness of your turn when turning.

Operation - Freewheel Mode

In order to prevent the wheelchair from rolling away, ensure that the wheelchair is on a level and dry surface before releasing the brakes.

In order to avoid personal injury do not use your Permobil in freewheel mode without an attendant present. Do not attempt to put the wheelchair in freewheel mode by yourself while seated in it.

Do not put the wheelchair in freewheel mode while on an incline. This could cause the wheelchair to roll on its own, causing injury and property damage, including damage to the wheelchair.

Safety Instructions



NOTE

Driving on a Loose or Soft Surface

When the wheelchair is set to its lowest speed and the batteries are not fully charged, driving on certain surfaces, for example gravel, sand or thick carpeting, can involve constrained navigability.

Driving in Darkness

Driving in the dark may only be done if your wheelchair is equipped with functioning lighting in the front and the back, or as per the applicable national or local traffic regulations.

Driving in Extreme Climate Conditions

Permobil's wheelchairs are designed to withstand most adverse weather conditions, however to minimize the risk of being caught in difficult situations you should avoid using the wheelchair outdoors during, for example, severe cold, heavy rain or thick snow.

Also bear in mind that certain surfaces on the wheelchair can be heated up or cooled down in the event of prolonged exposure to intense sunlight or cold respectively.

Safety Instructions



WARNING

Driving with Seat Lift/Seat Tilt/Backrest Recline

Be careful in making sure that nothing gets stuck between the chassis and the seat when the seat lift/seat tilt is operated. Operating the seat lift, seat tilt/ backrest recline changes the center of gravity and increases the risk of tipping over. Always drive in low speed and only use those seat functions on level ground, and not on hills, ramps, slopes or other inclines. Using those seat functions while driving on inclines can lead to personal injury and property damage, including damage to the wheelchair.

Center of Balance

The possibility of this wheelchair tipping and the point where this wheelchair will tip forward, back or to the side depends on its center of balance. Please note that the following factors can affect the wheelchair's center of balance:

- Elevation of the seat
- Height and angle of the seat/backrest
- Body position or weight distribution
- Driving on an incline such as a ramp or a hill
- Use of a backpack or other accessories, depending on the amount of weight added.

If your wheelchair begins to move in an unexpected manner, immediately release the joystick to stop the wheelchair. Except in an emergency, do NOT use the on/off button to stop your wheelchair. This will cause the wheelchair to stop abruptly and may cause personal injury.

Fixed Seat Post

Adjusting the seat height may only be performed by an authorized service provider. See the Service Manual for more information.

Safety Instructions



WARNING

Positioning Belt

Permobil positioning belts are designed to position the user only and will not protect you in an accident. You may even receive further injury from the belts.

Support Wheels

If your wheelchair is equipped with support wheels, they must always be mounted when the wheelchair is being driven.

Transfer into and out of the chair

Be sure that the power is turned OFF before entering or leaving the wheelchair and before lifting the control side armrest.

When transferring into or out of the wheelchair, every precaution should be taken to reduce the distance between the wheelchair and the place to which the user is transferring. Overextending this distance can cause user to overexert, lose balance, or fall.

Permobil recommends that users transfer in the presence of or with the assistance of an attendant.

Use caution when bending or reaching.

Never use the joystick as a handhold or point of support.

Do not use foot plates or armrests as supports when transferring into or out of the wheelchair. The footplates and armrests are not designed to be weight-bearing structures. Excessive force may cause them to give way, resulting in personal injury or property damage, including damage to the wheelchair.

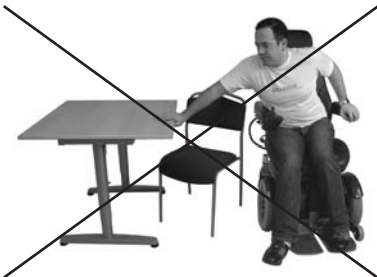

Safety Instructions



WARNING

Passengers

The wheelchair is not intended to transport passengers, regardless of the age of the passenger. The Maximum User Weight stated in the Owner's Manual for your seating includes the user and any personal effects. The Maximum limit should not be exceeded. The wheelchair's maneuverability and stability can be degraded as a result.

Environmental Conditions

Protect your wheelchair from exposure to any type of moisture, including rain, snow, or wash. Exposure to moisture can cause the chair to short-circuit, catch fire and cause personal injury or property damage. Do not operate your wheelchair if it has been exposed to moisture until it has dried completely.

If any of the shrouds or the joystick boot has cracks or tears, they must be replaced immediately. Failure to do so can allow moisture to enter the electronics and cause personal injury or property damage, including fire.

Do not operate your wheelchair in icy or slippery conditions. These conditions can lower the performance and safety of your wheelchair which could lead to an accident, personal injury and property damage, including damage to the wheelchair.

NOTE: *Extreme care should be exercised when using oxygen in close proximity to electric circuits and other combustible materials. Contact your oxygen supplier for instruction in use of oxygen.*

Safety Instructions



WARNING

Transport

The wheelchair must be transported in or with transport solutions that have been approved for this purpose.

Check that the wheelchair is properly secured and that the wheel locks are not disengaged. The wheelchair can be locked into position by running fastening straps through the brackets at the front and back. Also check that the fastening points on the transport vehicle are well-anchored.

A defectively fastened chair can cause serious injury to persons in the vehicle and serious damage to the vehicle.

Use Prohibited in Motor Vehicles

Permobil recommends that users NOT be transported in any kind of vehicle while in their wheelchair, unless the user is in an approved Permobil wheelchair configuration, has secured the wheelchair using a Permolock C, and is using a seatbelt attached to the vehicle. The only other safe alternative is that users be transferred into factory vehicle seating for transportation and use safety restraints made available by the auto industry. The only wheelchair transportation system Permobil recommends is a Permolock C used in combination with an approved Permobil wheelchair.

Unless using a Permolock C with an approved Permobil wheelchair, never sit in your wheelchair while in a moving vehicle. In an accident or sudden stop, you may be thrown from the chair and seriously injured or killed.

Permobil positioning belts are designed to position the user only and will not protect you in your vehicle if you are in an accident.

Safety Instructions



WARNING

Maintenance and Service

Carry out only the service and maintenance which are stated in the Owner's Manual. All other service and maintenance must be performed by a qualified service technician authorized by Permobil to perform such service on Permobil products

During all work on the electrical system of the wheelchair, the Circuit Breaker must always be in OFF position. To avoid the risk of electric shock, use extreme caution when using metal objects while working on the batteries. Short-circuiting can easily cause an explosion. Never perform service on the wheelchair without using protective gloves and goggles. Failure to do so can lead to personal injury.

Do not use parts or accessories not authorized by Permobil. Use of unapproved "aftermarket" accessories and parts may cause changes in the wheelchair, which may make the wheelchair unstable or uncontrollable. Such use may also void the warranty on the wheelchair.

Connecting any unapproved electrical or electronic devices to the wheelchair's electrical system can cause damage to the chair and caused the chair to become uncontrollable or drive erratically. Such use may also void the warranty.

The wheelchair is heavy and contains many moving parts, which means that the risk of being caught between them is always present.

Charging of Batteries

Charging must be done in a well-ventilated room, not in a wardrobe or closet. Charging must not be done in a bathroom or wet room. Only chargers with a max 10 A charging current (average value) may be used (the RMS value of the charging current must not exceed 12A). When the charger is connected, the chair must not and cannot be driven.

Safety Instructions



WARNING

Safety Circuits

Permobil products are equipped with safety circuits. Inhibit circuits prevent the wheelchair from driving under certain conditions. Speed reduction circuits limit the wheelchair's maximum speed under certain conditions. Limit switch circuits limit the wheelchair's functions under certain circumstances. Overload protection circuits shut the wheelchair off in case of an overload. The user should stop using the wheelchair immediately and consult an authorized Permobil distributor if any of these circuits should become disabled.

Any attempt to modify the safety circuits will result in unsafe operation of the wheelchair and could cause the chair to become unstable or uncontrollable. Such modifications may also void the wheelchair's warranty.

Changing Batteries and Fuses

The Circuit Breaker must always be in OFF-position when batteries and fuses are replaced.

Observe care in the use of metallic objects when working with batteries. A short-circuit can easily cause an explosion. Always use protective gloves and protective eye-glasses.

Filling Air into tires

Check at regular intervals that the wheelchair's tires have the prescribed tire pressure. Incorrect tire pressure can cause deteriorating stability and maneuverability.

The prescribed tire pressure is 29-36 psi (200-250 kPa).

Note that overfilling causes a risk of explosion.

Safety Instructions



WARNING

Changing Tires

Avoid the use of sharp-edged tools when working with tires.

If the wheel bolt is removed for tire service, replace it with a new, unused part from Permobil and tighten the bolt to the recommended torque. Also, inspect the drive axle and wheel rim for any damage. Damage to either part can cause the wheel bolt to loosen or fracture. Permobil recommends that wheel bolts be used only one time.

Storage

The wheelchair and its accessories must always be shut off when they are not being used. Always store the wheelchair so that access for unauthorized individuals is avoided.

Never store the wheelchair in a room in which condensation can arise (mist or dampness on the surfaces) e.g. in pool areas, laundry rooms, or similar rooms.

If you are unsure as to how your wheelchair and its accessories should be properly stored, contact your supplier or Permobil for more information.

Damages/malfunctions on the wheelchair and its accessories

If you experience that the wheelchair in any manner is not behaving as expected or if you suspect that something is wrong: Stop driving as soon as possible, shut off the wheelchair and contact your service contact or Permobil for more information.

It's also of greatest importance that Permobil be informed if the wheelchair and its accessories have been subjected to transport damages, damages during driving or damages due to another cause as soon as possible after the event. There exists a risk that the wheelchair and its accessories can no longer be used in a safe and secure manner.

Safety Instructions



NOTE

Recycling of Batteries

Used or broken drive batteries should be taken care of in an environmentally correct manner in accordance with locally applicable recycling directions.

EMC Requirements

The electronics of an electrical wheelchair can be affected by external electromagnetic fields (for example from mobile telephones). Similarly, the electronics of the wheelchair itself can also emit electromagnetic fields that can affect the immediate surroundings (for example certain alarm systems in businesses).

The limit values for Electromagnetic Compatibility (EMC) with respect to electrical wheelchairs is set in the harmonized standards for the EU in the Medical Devices Directive, No. 93/42/EEC.

Permobil's electronic wheelchair's comply with these limit values.

Also see Important Information about **Electromagnetic Interference (EMI)** on page 73-74.

Design & Function

General

The Permobil C500 is an electric front-wheel drive wheelchair for outdoor and indoor driving. It is intended for people with physical disabilities.

The wheelchair consists of a chassis and a seat. The chassis contains the wheelchair's electronics, power supply and drive functions. The seat consists of a seat frame, seat plate/back rest, arm rest/leg rest, seat lift/fixed seat tube and any accessories/options such as a head rest, calf rest, chest support, etc.

In this owner's manual, we have chosen to show the wheelchair with our Corpus-seat. However, the operation of the chassis and most of its functions are the same regardless of the seat model chosen.

Overview



- | | |
|------------------|--------------------------------|
| 1. Back rest | 6. Front wheels (drive wheels) |
| 2. Control panel | 7. Rear wheels |
| 3. Seat | 8. Chassis |
| 4. Leg rest | 9. Arm rest |
| 5. Foot plates | |

Seat

The Permobil C500 can be combined with different seat models, which are supplied with a separate owner's manual.

Seat lift

The Permobil C500 can be fitted with an electrically controlled seat lift that allows the seat to be raised steplessly up to 7 3/4" in order to adjust the height to tables, benches, etc.

Seat angle

The Permobil C500 can be fitted with an electrically controlled seat angle function that makes it possible to adjust the seat angle steplessly up to 45°.

Both the seat lift and seat angle are controlled via the control panel or via an additional key box (if your wheelchair is fitted with one) in connection with the control panel.



NOTE

User weight over 100 kg.

If the user's weight exceeds 100 kg, the wheelchair can be fitted with safety circuits for the seat system to guarantee the wheelchair's stability. The circuits prevent the seat angle/back angle being tilted backwards when the seat lift is raised from its lowest position and the raising of the seat lift being blocked when the angle of the back rest exceeds 45 degrees.



Seat lift



Seat angle

Driving

The wheelchair has a drive pack for each drive wheel. The motors regulate the speed, turning and braking. A joystick on the control panel sends signals to the electronics unit. The electronics unit then controls the motors.

Shock absorbers

The wheelchair is fitted with two shock absorbers with adjustable spring force. If no specific user weight was specified in connection with delivery of the wheelchair, the shock absorbers are set to a standard value corresponding to a user weight of 50 - 70 kg.

Adjustment of the spring force

The adjustment should be performed by personnel who are very familiar with the design and function of the shock absorbers. If adjustment is required, please contact your nearest service engineer/service center or Permobil service.

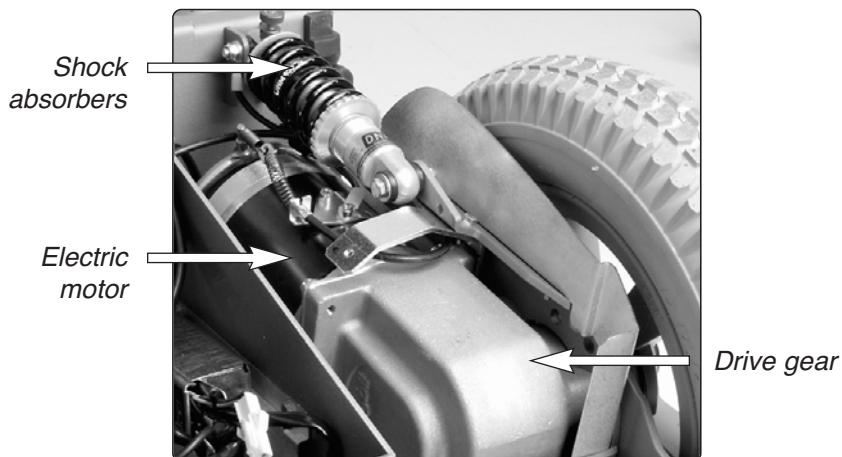

Wheels

The wheelchair's front wheels, the drive wheels, have pneumatic tires. The rear wheels, the steering wheels, may have pneumatic or solid rubber tires.

Lights and reflectors

In the standard version, the wheelchair is fitted with reflectors at the front and rear and on the sides.

Front/rear lights and indicators are available as accessories.



Front reflectors



Rear reflectors



Side reflectors

Electronics

Batteries

The wheelchair's two batteries are located under the rear chassis cover and are easily accessible for maintenance and replacement.

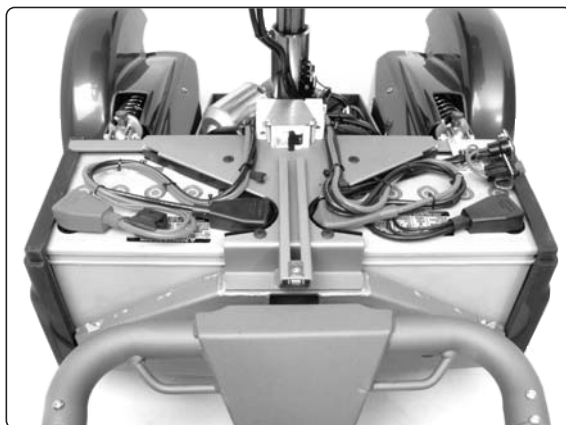

Position of the batteries



WARNING

Be careful when using metal objects when working with batteries. A short-circuit can easily cause an explosion. Always use safety gloves and safety goggles.

Remember that the batteries are heavy and must be handled with great caution.



NOTE

Used or malfunctioning batteries should be disposed of responsibly in accordance with local recycling regulations.

Electronics

Fuses/charging socket

Main fuse/battery isolator

The Permobil C500 is fitted with a 63 A or 80 A automatic main fuse that can be reset when it has been triggered. It also functions as a battery isolator and is controlled (ON/OFF) via the lever located above the left battery cover.

15 A charging fuse/charging socket

The charging fuse is located under the rear chassis cover and the charging socket is located on the right side of the rear chassis cover and is covered by a rubber protector.

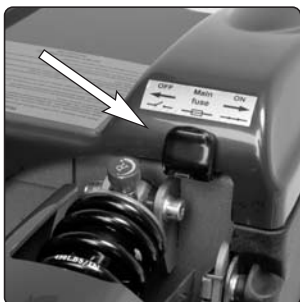

Lever for automatic main fuse

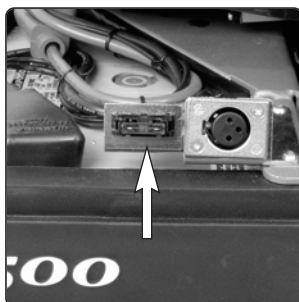

15 A charging fuse

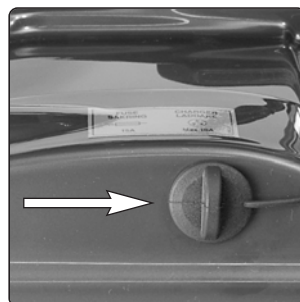

Charging socket



NOTE

Always switch off the power supply to the control panel before interrupting the power with the main fuse.



WARNING

If the main fuse is triggered, there is often a major electrical fault. The cause of the fault should be checked carefully before the switch is reset. Contact Service in case of doubt.



WARNING

Always switch off the power supply to the control panel before changing the charging fuse. The battery charger must not be connected when the charging fuse is being changed.

If the charging fuse is triggered, there may be problems or faults with batteries, the charger/charging cables or the wheelchair's charging socket.

The cause of the charging fuse being triggered should be checked carefully before the fuse is changed.

R-Net's control panel

The control panel consists of a joystick, function keys and an LCD screen. On the rear of the panel are also the charging contact and two jack contacts.

In addition to the control panel, your wheelchair may also be fitted with an additional control panel for the seat.

Overview of the control panel



Charging socket

This socket is used only to charge or lock the wheelchair. Do not connect any programming cable to this socket. The socket must not be used as a power source for any other electrical equipment. Connecting other electrical equipment may damage the control system or lead to the wheelchair having poorer electromagnetic compatibility (EMC).

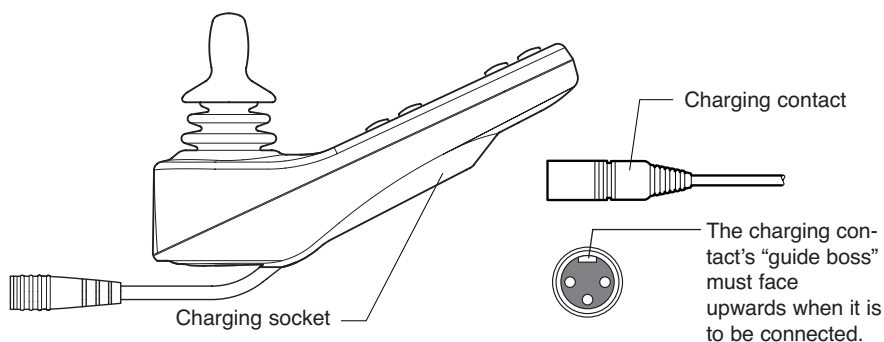

NOTE

For faster, more efficient charging, we recommend that you use the wheelchair's charging contact on the chassis. See page 55.



WARNING

The wheelchair's warranty ceases to apply if any equipment other than the battery charger belonging to the wheelchair or the key used for locking is connected to the control panel's charging contact.

R-Net control panel

Function keys

There are a total of 10 function keys on the control panel.

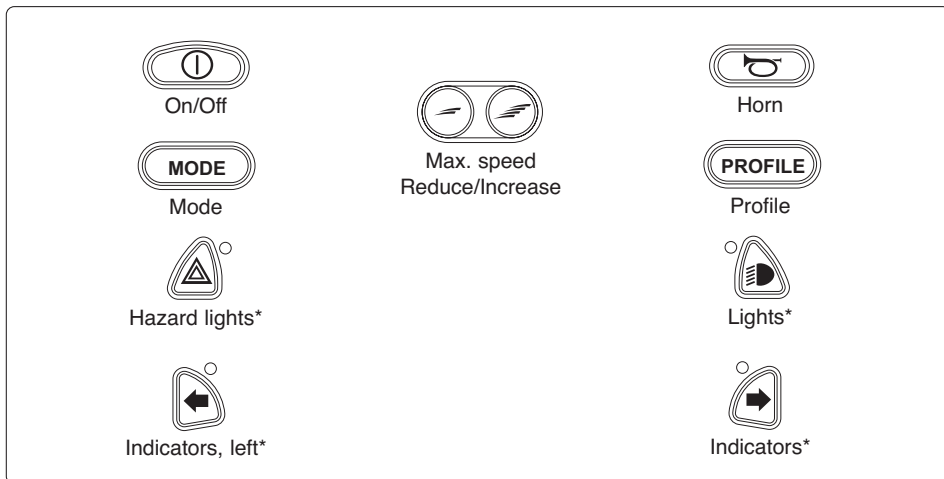

* Applies only if the wheelchair is fitted with lights.

On/off key

The on/off key is the switch for the control system's electronics which, in turn, supply power to the wheelchair's motors.

WARNING

Do not use the on/off key to stop the wheelchair, except in an emergency. You can be thrown out of the chair or reduce the life of the wheelchair's drive system.

Horn

Press the switch to produce a signal to attract attention.

Max. speed

These keys normally reduce or increase the wheelchair's maximum speed. Depending on how the control system has been programmed, a temporary screen may be displayed when this key is pressed.

R-Net control panel

Mode

The user can use the Mode key to scroll between the control system's available modes. The available modes depend on the programming and on which other output devices are connected to the control system.

Profile

The user can use the Profile key to scroll between the control system's available profiles. The number of available profiles depends on how the control system has been programmed. Depending on how the control system has been programmed, a temporary screen may be displayed when this key is pressed.

Hazard lights*

This key activates and deactivates the wheelchair's hazard lights. Hazard lights are used when the wheelchair is stationary in a position which may represent a risk or an obstacle for others. Press this key to activate the hazard lights. Press it again to deactivate them. When the hazard lights are active, the indicator lamp next to the control key flashes in time with all the indicators on the wheelchair.

Lights*

This key activates and deactivates the wheelchair's lights. Press this key to switch the lights on. Press it again to switch them off. When the lights are activated, the indicator lamp next to the control key is also switched on.

Indicators, left*

This key activates and deactivates the wheelchair's left indicators. Press this key to activate the indicators. Press it again to deactivate them. When the indicators are active, the indicator lamp next to the control key flashes in time with the left indicators on the wheelchair.

Indicators, right*

This key activates and deactivates the wheelchair's right indicators. Press this key to activate the indicators. Press it again to deactivate them. When the indicators are active, the indicator lamp next to the control key flashes in time with the right indicators on the wheelchair.

*) Applies only if the wheelchair is fitted with lights.

R-Net control panel

Socket for external on/off key

You can use this socket to activate and deactivate the control system with an external device.

Socket for external profile key (applies if profiles are programmed and used).

You can use this socket to select a profile with an external device.

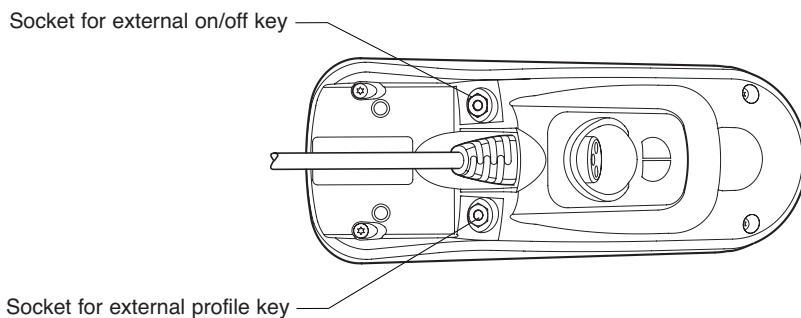

R-Net control panel

Display

By looking at the control panel display, you can get an idea of the status of the control system. The control system is active when the screen is lit.

Symbols

R-net's display has symbols that are always displayed and symbols that are only displayed under certain conditions. Below is the typical appearance of the display when driving with profile 1.



Battery indicator

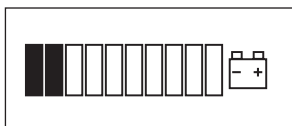

The battery indicator displays the status of the battery.

Constantly on

This shows that everything is working correctly.

Flashing slowly

The control system is working correctly but the battery needs to be charged as soon as possible.

Moving

The wheelchair's batteries are being charged. The wheelchair cannot be driven until the charger has been disconnected and the control system has been restarted.

Speed indicator



This displays the current speed setting.

The speed setting is adjusted using the keys for higher and lower speed.

Current profile



The profile number describes the profile currently being used by the control system. The profile text is the name or description of the profile currently being used by the control system.

In focus



When the control system has more than one method for direct control, like another joystick module or a double module for companion control, the module currently controlling the wheelchair displays the In focus symbol.

Speed limitation

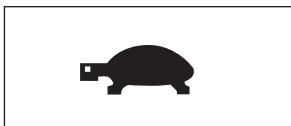

This symbol is displayed when the wheelchair's speed is limited, for example when the seat is raised. If the wheelchair is prevented from driving, the symbol flashes.

Restart



This symbol flashes when the control system needs to be restarted, for example after a unit in the system has been replaced.

Fault



The control system can detect a large number of faults. When the system has detected a fault that is not serious enough to cause a stoppage, this symbol is displayed.

Motor temperature

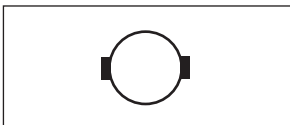

This symbol is displayed when the control system has intentionally reduced the power supply to the motors to protect them against overheating.

Control system temperature

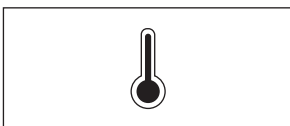

This symbol is displayed when the control system has intentionally reduced its own power supply to protect itself against overheating.

Timer



This symbol is displayed when the control system switches between different stages. For example, it may be displayed when you enter programming mode. The symbol is animated so that you can see the sand running through the hourglass.

Emergency stop



If the control system has been programmed for locked operation or automatic adjustment of the seat, an emergency stop key is normally connected via the jack contact for an external profile key. If the emergency stop key is used or disconnected, this symbol flashes.

Locking the control system

The control system can be locked in two different ways. These are using a key sequence on the keypad or with a physical key. How the control system is locked depends on how the system is programmed.

Locking with the keypad:

- Press and hold down the on/off key while the control system is active.
- After 1 second, the control system emits a beep. Release the on/off key.
- Move the joystick forwards until the control system emits a beep.
- Move the joystick backwards until the control system emits a beep.
- Release the joystick. You will hear a long beep.
- The wheelchair is now locked.

The following screen is displayed:

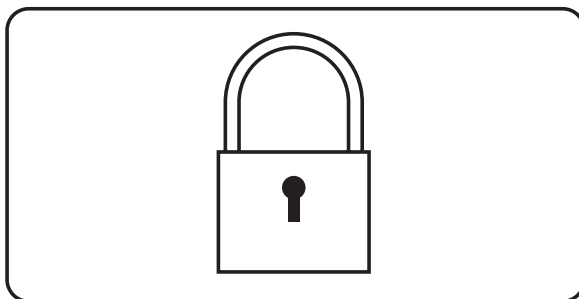

Unlocking:

- Press the on/off key if the control system is switched off.
- Move the joystick forwards until the control system emits a beep.
- Move the joystick backwards until the control system emits a beep.
- Release the joystick. You will hear a long beep.
- The wheelchair is now unlocked.

Locking with a key

- Insert and remove the key from the charging contact on the joystick module.
- The wheelchair is now locked.

The following screen is displayed:

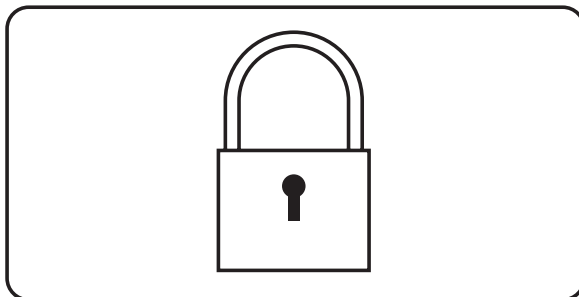
**Unlocking:**

- Insert and remove the key from the charging contact.
- The wheelchair is now unlocked.

Operation

General

The Permobil C500 is designed for use both indoors and outdoors. When you drive indoors, you must be careful in, for example, narrow passages, when going through doors and entrances and when using lifts, ramps, etc.

You should also consider the risk of crushing when you use the electric seat lift and seat angle functions, above all if the wheelchair has been driven under tables, benches, etc. Outdoors you should remember to drive very slowly down steep slopes and to be very careful when driving on uneven surfaces, up slopes, on side slopes and over obstacles. Always observe a good safety distance when driving near edges and precipices.

We recommend that you do repeated test drives in an environment in which you feel safe so that you are very familiar with how the wheelchair and its accessories behave in different situations before you start to use the wheelchair on public roads and in other public locations.

General - Driving

Check that the control panel is correctly fitted and the joystick is in the neutral position. Ensure that you have good support, for example the wheelchair's arm rest, for the part you use to handle the joystick with. Do not just use the joystick as a support. Fast turns and driving on uneven surfaces can interfere with your ability to handle the wheelchair safely.

1. Switch on the power by pressing the start key on the control panel.
2. Select a suitable driving profile with the PROFILE key (if the system is programmed for more than one driving profile).
3. Move the joystick carefully forwards to drive forwards or backwards to reverse.
4. The speed setting is adjusted using the keys for higher and lower speed. The wheelchair's electronics allow very slow driving over edges. You can drive up to the edge and then carefully drive over it.

Joystick Error - R-net electronics

If the joystick was moved away from the central position before, during and immediately after the time at which the control system was switched on, the screen for a shifted joystick is displayed for 5 seconds. If the joystick is not released during this time, a joystick error is registered and the wheelchair cannot be driven. To be able to drive the wheelchair again, ensure that the joystick is in the central position. Then switch the wheelchair off and on again.

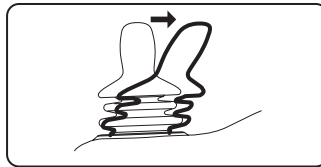

Screen: Shifted joystick

If the wheelchair still cannot be driven after the restart and a “Diagnostics screen” is displayed (see example below), R-net has detected an error in the wheelchair's electronics that needs to be remedied. You should contact your service contact as soon as possible.

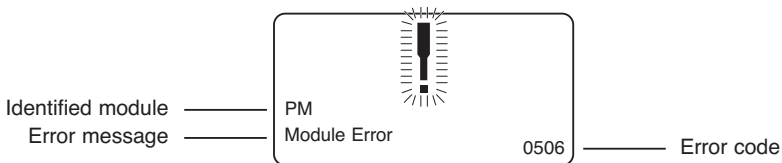

Driving technique

The control panel's electronics "interpret" the movements of the joystick and move the wheelchair as intended. For normal driving, the user needs to employ no complex techniques, which is an advantage if the user is inexperienced. A good way of starting is quite simply to move the joystick in the direction you want to go. The wheelchair then moves in the direction in which the joystick is pointing.

However, always remember to drive as gently as possible and to avoid sudden braking and evasive maneuvers.

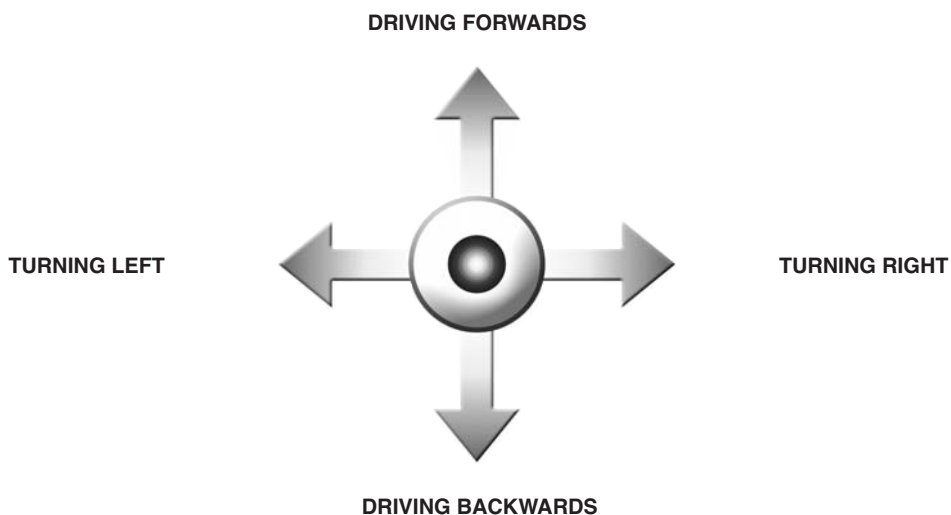

**NOTE**

Do not take the first test drive on your own. The test drive is intended to establish how you and the wheelchair work together and you may need assistance.

Before driving, check that the brake release lever is in the drive position.

**WARNING**

Do not just use the joystick as a support. Fast turns and driving on uneven surfaces can interfere with your ability to handle the wheelchair safely.

If the wheelchair moves in a way that you do not want, **RELEASE THE JOYSTICK!**

This always makes the wheelchair interrupt the current movement.

Seat functions

(Not applicable to all seat models)

On some seats the electrical functions can be controlled with the help of the control panel joystick. Some models are equipped with three memory locations. Each memory location can store the position of the seat's adjustment device. This means that it is easy to retrieve a seat position saved earlier.

Maneuvering the seat

1. Press the "Mode" button one or more times until an icon for seat function appears in the control panel display - see illustration.
2. Move the joystick to the left or right to select a seat function. The icon for the seat function selected appears in the display.
3. Move the joystick forwards or backwards to activate the function.

Below is an example of the icons that may be shown in the display. Which icons are shown varies depending on the seat model and available functions.



Seat function activated.

⚠
NB

If the symbol "M" appears together with the seat icon, this means that a memory function has been activated. Move the joystick to the left or right to choose a seat function instead.

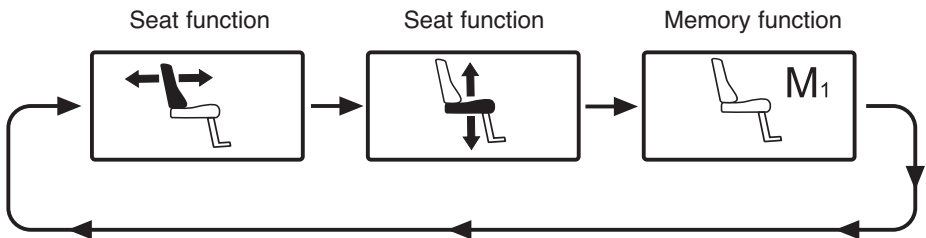

*Move the joystick to the left or right to select a function.
The icon for the function selected appears in the display.*

Seat functions

(Not applicable to all seat models)

Return to drive mode

Press the "Mode" button one or more times until a standard display image with speed indicator appears in the control panel display - see illustration.



Standard display image with speed indicator.

Seat functions

(Not applicable to all seat models)

The control system on some seats has three memory locations for seat positions. Each memory location can store the position of the seat's adjustment device. This means that it is easy to retrieve a seat position saved earlier.

Retrieving position from memory

1. Press the "Mode" button one or more times until a seat icon appears in the control panel display.
2. Move the joystick to the left or right to select a memory location (M1, M2 or M3). A seat icon and memory symbol "M" for the memory location selected are shown in the control panel display - see illustration.
3. Move and hold the joystick forwards. The seat adjusts to the position stored earlier. For reasons of safety, the joystick must be held forwards until the seat is fully adjusted to the required position. Once the seat has adjusted to the saved position, it stops moving.

⚠ NB

Movement of the seat can be stopped at any time by releasing the joystick.

Return to drive mode

Press the "Mode" button one or more times until a standard display image with speed indicator appears in the control panel display - see illustration.



Memory function activated.



Standard display image with speed indicator.

Seat functions

(Not applicable to all seat models)

Saving position to memory

1. Set the seat's electrical functions to the desired mode.
2. If not activated, activate the seat/memory function by pressing the "Mode" button one or more times until a seat icon appears in the control panel display.
3. Move the joystick to the left or right to select a memory location (M1, M2 or M3). A seat icon and memory symbol "M" for the memory location selected are shown in the control panel display - see illustration.



Memory function activated.

4. Move the joystick backwards to activate the "save" function. An arrow will appear next to the memory symbol "M" - see illustration.
5. Save the current position by moving the joystick forwards and holding it in that position until the arrow next to the memory symbol "M" disappears.



Save function activated.

Return to drive mode

Press the "Mode" button one or more times until a standard display image with speed indicator appears in the control panel display - see illustration on previous page.

Driving rules

Support wheels

Your wheelchair may be fitted with front support wheels to reduce the risk of tipping when driving over obstacles, etc. They must always be fitted when you drive.

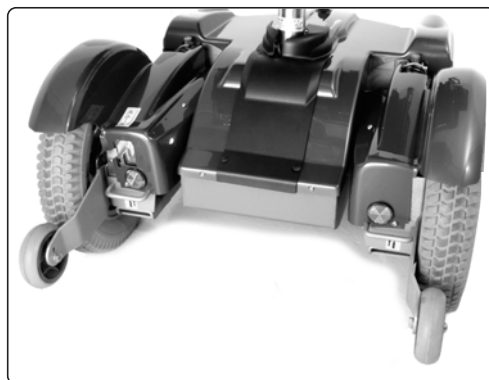

Front support wheels



WARNING

If your wheelchair is fitted with support wheels, they must always be fitted when you drive. There is a risk of tipping.

Always be aware that high speed and a longer braking distance mean a greater risk of accident.

Never drive fast/at full speed in narrow passages, on narrow pavements, etc. because an incorrect maneuver/steering error can lead to a risk of accident.

Remember that a surface that is closed at the side will affect the wheelchair and may make it steer sideways. Therefore, never drive at full speed on surfaces that are closed at the side.

Using the seat angle function shifts the center of gravity, which may have a negative effect on the driving properties. So never drive at full speed if the seat has been angled a long way.

Driving over obstacles

Do not drive the wheelchair over obstacles higher than 3 inches. If you drive over higher edges, there is a higher risk of tipping and of damage to the wheelchair.

You should always drive over obstacles with great caution.



WARNING

Do not drive the wheelchair over obstacles higher than 3 inches. You should always drive over obstacles with great caution.

WARNING

A raised seat lift/seat angle/back angle changes the center of gravity and increases the risk of tipping. Therefore, use these seat functions only on flat surfaces and always drive with great caution and at low speed.

Driving downhill

You should always drive downhill at low speed and with great caution.

Avoid braking suddenly and sudden evasive maneuvers and never drive so fast that you are unable to control the wheelchair safely without risks.

You should be extremely careful when driving downhill on an uneven surface (for example grass, gravel, sand, ice and snow).



WARNING

Do not drive downhill on a gradient greater than 12°. Dynamic stability according to ISO 7176-2 = 6°.



WARNING

A raised seat lift/seat angle/back angle changes the center of gravity and increases the risk of tipping. Therefore, use these seat functions only on flat surfaces and always drive with great caution and at low speed.

Driving uphill

You should always drive uphill with great caution.

Avoid sudden evasive maneuvers and never drive so fast that you are unable to control the wheelchair safely without risks.

You should be extremely careful when driving uphill on an uneven surface (for example grass, gravel, sand, ice and snow).

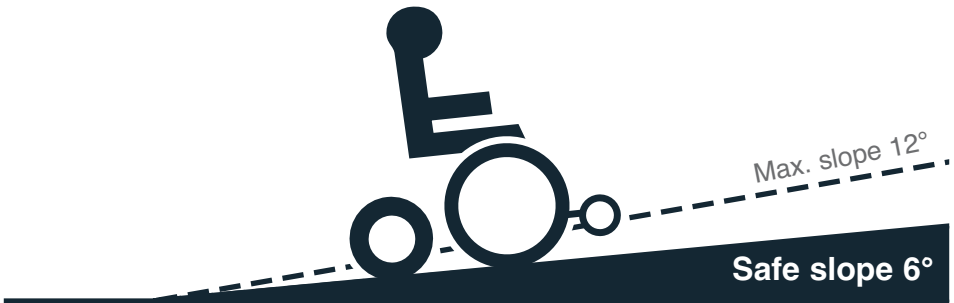

WARNING

Do not drive uphill on a gradient greater than 12°. Dynamic stability according to ISO 7176-2 = 6°.



WARNING

A raised seat lift/seat angle/back angle changes the center of gravity and increases the risk of tipping. Therefore, use these seat functions only on flat surfaces and always drive with great caution and at low speed.

Driving on side slopes

You should always drive on side slopes with great caution.

Avoid sudden evasive maneuvers and never drive so fast that you are unable to control the wheelchair safely without risks.

You should be extremely careful when driving on side slopes with an uneven surface (for example grass, gravel, sand, ice and snow).



⚠ WARNING

Do not drive the wheelchair on side slopes steeper than 10 degrees. There is a risk of tipping.

⚠ WARNING

A raised seat lift/seat angle/back angle changes the center of gravity and increases the risk of tipping. Therefore, use these seat functions only on flat surfaces and always drive with great caution and at low speed.

Handling the manual brake release

The wheelchair is fitted with a manual brake release that can be released to make it possible to move the wheelchair manually. The brake release lever is located at the front on the right wheel cover.

Releasing the brakes

1. Switch off the wheelchair with the On/Off key on the control panel.
2. While pressing the lever's safety catch to the right to lock the lever, move the lever upwards to release the brakes. The chair can now be moved manually.

Resetting released brakes

1. Move the lever upwards so that the safety catch is released and then press the lever down so that it assumes in its lowest position.

NB! Always check that the release lever goes right down to its lowest position.



Brakes released with safety catch

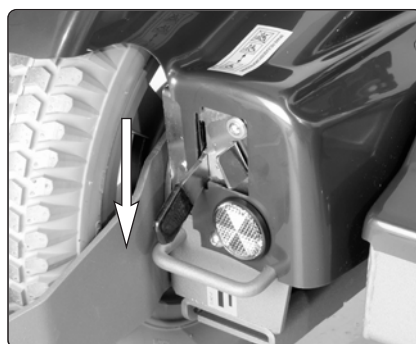

Brakes activated

WARNING

Never use the wheelchair on a sloping surface with the brakes released.

Always ensure that the wheelchair is switched off when the brakes are activated/deactivated.

To prevent the wheelchair from rolling off, ensure that it is on a dry, level surface before releasing the brakes.

Anyone who pushes a wheelchair with the brakes released must ensure that this is done safely without risks.

Always reset the brake release after moving the wheelchair manually.

When the brakes are released, it should not be possible to drive the chair. If the chair can still be driven, contact your service contact or Permobil immediately.

Charging batteries

When should the batteries be charged?

How frequently you need to charge the batteries in your wheelchair depends on a number of factors, including how you use your wheelchair, the temperature and age of the batteries and how they are made. All batteries also gradually lose capacity as they age.

The most important factor for the life of the batteries is how much power is taken out of them before they are charged and how often they are charged/discharged.

To achieve the best life, the batteries should not be discharged completely. Always charge the batteries immediately after they have been discharged.

If the battery voltage indicator shows that the batteries appear to be losing power faster than normal, the batteries may be worn out and need to be replaced.

WARNING

Use only the charger supplied with your wheelchair or recommended by Permobil. Using other chargers may damage the batteries, the wheelchair electronics or the charger itself. It may also result in parts becoming overheated, which may entail a greater risk of fire.

Be careful when using metal objects when working with batteries. A short-circuit can easily cause an explosion. Always use safety gloves and safety goggles.

You may only use a charger with a maximum charging current of 10 A (average)

(the effective value of the charging current must not exceed 12 A).

The batteries must be charged in a well-ventilated room, not in a wardrobe. The batteries must not be charged in a bathroom or wetroom.

If you want to interrupt the charging process, the mains voltage should be switched off before the charging contact is disconnected from the wheelchair's charging socket. This is to avoid sparking and unnecessarily high wear on the charging contact.

The charger's charging cable must not be extended.

The charger may get hot and must not be covered. The charger must be placed so that it has free space on all sides.

The charging contact must be replaced if it is damaged or gets hot during charging. Both the contact on the charger's cable and the wheelchair's charging socket should be replaced if one part is damaged or worn. The contacts must be replaced by qualified personnel.

Charging

Ensure that the wheelchair is switched off with the On/Off key on the control panel and then connect the charging plug to the wheelchair's charging socket. The battery voltage indicator on the wheelchair's control panel lights up and shows the charging status during charging.

After charging has been completed, the wheelchair must be switched off and on again with the On/Off key on the control panel before it can be driven.



NOTE

CAREFULLY READ THE INSTRUCTIONS SUPPLIED WITH THE CHARGER BEFORE STARTING TO CHARGE THE WHEELCHAIR.



NOTE

Switch off the wheelchair with the On/Off key on the control panel before charging but ensure that the main fuse is in the ON position.

Ensure that the charging contact has been fully inserted in the wheelchair's charging socket.

The wheelchair cannot be driven when the charger is connected.

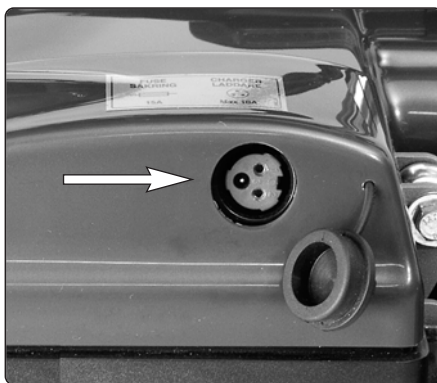

Charging socket

Transport

The wheelchair must only be transported in vehicles approved for this purpose.

Check that the wheelchair is properly secured and the brakes are not released. The wheelchair can be locked in position with loading straps from the transport eyes at the front and rear, marked with yellow stickers.

Anchor the wheelchair with the vehicle's anchoring system and according to the manufacturer's instructions. Always check that the fixing points on the transport vehicle are well anchored.



NOTE

If your wheelchair is fitted with a luggage basket (accessory), it may be difficult, in some cases, to anchor the wheelchair in the rear transport eyes.

This can be solved by ordering an additional pair of rear transport brackets. Contact Permobil for order information for these brackets.

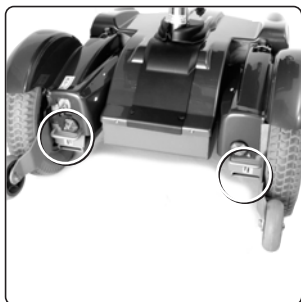

Front transport eyes

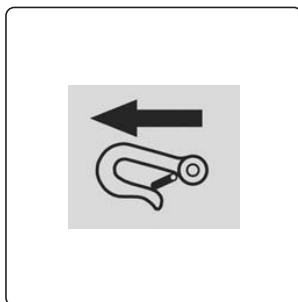

Sticker for transport eyes

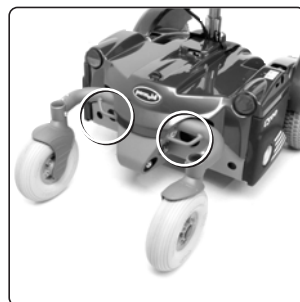

Rear transport eyes

**WARNING**

The wheelchair must only be transported in vehicles approved for this purpose.

Permobil recommends that users are **NOT** transported in any vehicle while seated in the wheelchair. The only safe alternative is for the user to move to a seat in the vehicle and to use the vehicle's safety belt system.

If the wheelchair has to be transported into the transport vehicle via a ramp or similar with the user in the wheelchair, the wheelchair must always be protected against tipping over backwards by a person behind the wheelchair.

Carefully check that the wheelchair is properly fixed and that the brake release has not been activated (the wheelchair drive wheels must be locked). The wheelchair can be locked in position with loading straps from the transport eyes at the front and rear, marked with yellow stickers.

Anchor the wheelchair with the vehicle's anchoring system and according to the manufacturer's instructions. Always check that the fixing points on the transport vehicle are well anchored.

An inadequately secured wheelchair could cause major damage and injury if it broke loose, both to persons in the transport vehicle and to the vehicle and the wheelchair itself.

Do not sit in the wheelchair in a moving vehicle. In the case of accident or a sudden stop, the user could be thrown from the chair with serious injuries as a consequence. Permobil's fixing belt is only designed to hold the user in place and gives no protection in the case of accident.

Any table or similar mounted on the wheelchair must be removed and secured in a separate location in the vehicle or secured safely to the wheelchair.

All other wheelchair accessories must be secured to the wheelchair or removed and secured in a separate location in the vehicle so that they do not come loose during transportation with the risk of injury to vehicle passengers in the event of a collision.

General advice for air transport

When transporting your wheelchair by air, you should primarily pay attention to the following three things:

1. Batteries

Gel batteries: In most cases, they do not need to be removed from the wheelchair.

If your wheelchair has an automatic main fuse, this must always be in the Off position.

Acid batteries: Most airlines require that batteries be removed from the wheelchair and transported in special boxes that the airline may provide.

2. The wheelchair's dimensions and weight

How much the wheelchair weighs and how large it is are important, depending on the type of airplane in which the wheelchair is to be transported. The smaller the airplane is, the smaller the wheelchair may be/weight and vice versa. Always check with the airline what rules apply.



NOTE

If you do not know what type of main fuse your wheelchair has, contact Permobil or your service contact. Some airlines may refuse to accept acid batteries on board.

General advice for air transport

3. Preventing damage

When transported by air, the wheelchair will be put with other goods in a confined space. Therefore, it is important to take preventive action to minimise transport damage to the wheelchair.

Cover the control panel with soft, shock-absorbing material (foam plastic or similar) and fold it in towards the back rest. Protect other protruding objects in a similar manner. Tape any loose cables to the seat or covers.



NOTE

To ensure that the wheelchair can be transported safely and no nasty surprises crop up at the last minute, you should always contact the airline before you travel.

Maintenance and repairs

To ensure that your wheelchair works well, it is important for it to be used correctly and regularly maintained. A well maintained wheelchair lasts longer and has a lower risk of faults.

Toolbag

The wheelchair comes with a toolbag with the following contents that can be used for maintenance and minor repairs.

TOOL	AREA OF USE
Allen keys	General maintenance/seat adjustment
11, 13 mm spanners	General maintenance/replacing batteries
Seat lift crank	Manually raising the seat lift
Security key	Locking/unlocking the wheelchair



NOTE

Some repairs may require tools other than those supplied with the wheelchair.



NOTE

The main fuse must always be switched off when batteries and fuses are replaced. Always switch off the power supply to the control panel before interrupting the power with the main fuse.



WARNING

Any unauthorized alterations to the wheelchair and its systems may lead to an increased risk of accident.

All alterations to and interventions in the wheelchair’s vital systems must be performed by a competent service engineer. In case of doubt, always contact a competent service engineer.

General - batteries/storage

- Please note that a battery discharges itself and that a discharged battery can burst when it is cold. If the wheelchair is to be stored unused for an extended period of time, the batteries must always be charged once a month to avoid them being damaged.
- The wheelchair must not be stored in areas subject to condensation (steam or moisture on surfaces), for example utility rooms or similar.
- The wheelchair may be stored in an unheated room. From the point of view of corrosion, it is best for the room to be a few degrees warmer than the surroundings as this keeps the room drier.
- If the wheelchair is fitted with acid batteries, the acid level should be checked regularly. If the wheelchair is fitted with gel batteries, the liquid level does not need to be checked.
- The life of the batteries depends entirely on regular charging.

Short-term storage

For the charging process to produce a battery with good capacity, the temperature in the storage room should not be lower than +5 degrees. If it is stored at a temperature below +5 degrees, there is a higher risk that the battery has not been fully charged when it comes to be used and also a higher risk of corrosion.

Long-term storage

The battery may be stored in an unheated room but it should be charged at least once a month for maintenance purposes.



WARNING

Be careful when using metal objects when working with batteries. A short-circuit can easily cause an explosion. Always use safety gloves and safety goggles.

Cleaning

Regular care and maintenance will prevent unnecessary wear and damage to your wheelchair. The following is general advice recommended by Permobil. For severe soiling of the upholstery or damage to the surface finish, contact Permobil for information.

Upholstery, cloth/vinyl

For normal cleaning, wash the upholstery with lukewarm water and a mild non-abrasive soap. Use a soft cloth or brush. Before the surface dries, wipe off any water/soap residues with a clean, dry cloth. This procedure may be repeated to remove stubborn dirt or stains.

If necessary, the cover may be removed before cleaning. See also the washing instructions on the upholstery materials.

Metal surfaces

For normal cleaning it is best to use a soft cloth/sponge, hot water and a mild detergent. Wipe down carefully with a cloth and water, and dry off.

Remove scuff marks from semi-matt surfaces with soft wax (follow manufacturer's instructions).

Remove scuff marks and scratches from shiny surfaces using car polish, either liquid or paste. After polishing, apply soft car wax to restore the original surface gloss.

Plastics

For normal cleaning, wash plastic surfaces with a soft cloth, mild detergent and hot water. Rinse thoroughly and dry with a soft cloth. Do not use solvents or abrasive kitchen cleaners.

Control panel

Use a soft cloth moistened with mild detergent and be careful when cleaning the joystick and the panel's display. Do not use solvents or abrasive kitchen cleaners. The panel must not be rinsed with water or any other liquid.

Checking the seat belts

Check the condition of the seat belts regularly in case any damage or worn places have developed.



WARNING

Never hose the wheelchair down as the electronics may be damaged. The wheelchair must always be turned off when being cleaned.

Wheels

Check at regular intervals that the wheelchair's tires have the correct tire pressure. The incorrect tire pressure may result in lower stability and maneuverability. Too low tire pressure also results in abnormal wear and shorter range. Therefore, check regularly that the tire pressure is 200-250 kPa (2-2.5 bar).

Filling tires with air

1. Unscrew and remove the plastic cap on the valve on the tire.
2. Connect the compressed air nozzle to the valve and adjust the tire pressure to the correct level.

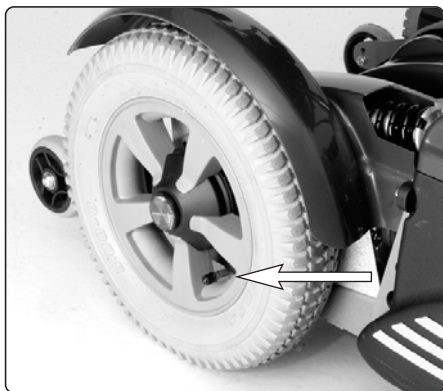

Filling valve, front tire

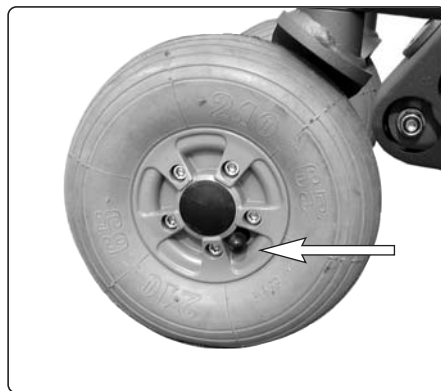

*Rear tire with Allen screws
and filling valve*

Inner tube replacement, front tire

1. Chock up the wheelchair so that the wheel turns freely and let out the air.
2. Take the tire off the wheel rim.
3. Replace the inner tube.
4. Put the tire back on the wheel rim and fill with air.

Inner tube replacement, rear tire

NB! Applies only if your wheelchair is fitted with pneumatic rear tires.

1. Chock up the wheelchair so that the wheel turns freely and let out the air.
2. Take the wheel rim apart by unscrewing the five Allen screws that hold it together.
3. Replace the inner tube.
4. Put the wheel rim together with the tire. Check that the inner tube is not caught between the halves of the wheel rim. Fill the tire with air.

**WARNING**

The recommended tire pressure for front and rear tyres is 200-250 kPa (2-2.5 bar). Overfilling entails a risk of explosion.

The incorrect tire pressure may result in lower stability and maneuverability. So check regularly that the tires have the correct pressure.

Fixing belts

Check the condition of the fixing belts regularly in case any damage or worn places have developed.

Brake release

Check regularly, approximately once a month, that the brake release and the brake release lever are working properly.

When the brakes are released, it should not be possible to drive the wheelchair.

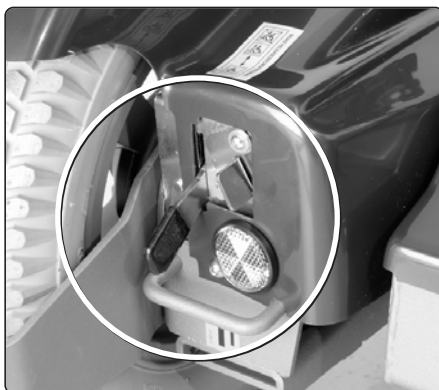

*Brake release lever
with safety catch*

Battery replacement

(see also the sticker on the inside of the battery covers)

1. Place the wheelchair on a level surface and, if possible, raise the seat lift for better access.
2. Switch off the power supply using the ON/OFF key on the control panel and switch the automatic main fuse to Off.
3. Undo the knob holding the rear part of the chassis cover and lift the cover up a little.
4. Undo the knobs that hold the battery covers in place and fold the covers down.
5. Use the battery strap to pull out each battery just far enough to allow you to disconnect the first battery connection.
6. Pull the batteries all the way out and disconnect the other battery connections.

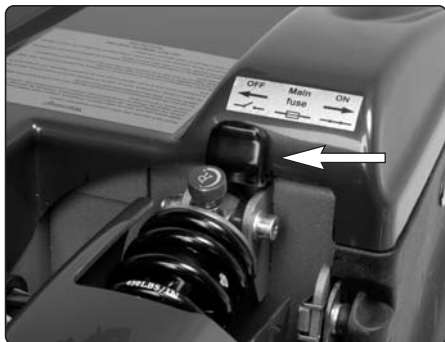

Main fuse in the OFF position



Battery cover/chassis cover knob



WARNING

Be careful when using metal objects when working with batteries. A short-circuit can easily cause an explosion. Always use safety gloves and safety goggles.

Remember that the batteries are heavy and must be handled with great caution.

Battery replacement

7. Lift the batteries away using the battery straps.
8. Use battery straps and insert new batteries in reverse order (leave the straps on the new batteries).
9. Close and lock the battery covers and chassis cover.
10. Switch the automatic main fuse to ON.

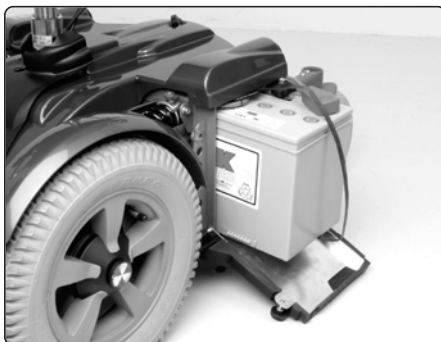

Pull out each battery



NOTE

Used or malfunctioning batteries should be disposed of responsibly in accordance with local recycling regulations.

Resetting the main fuse/battery isolator

WARNING

If the main fuse is triggered, there is often a major electrical fault. The cause of the fault should be checked carefully before the switch is reset. Contact Service in case of doubt.

The main fuse also functions as a battery isolator but it is called the main fuse in the owner's manual.

It is not normally necessary to replace the main fuse as it is automatic and can be reset when it has been triggered. It is reset by switching the switch to On.



Main fuse in the ON position

NOTE

Always switch off the power supply to the control panel before interrupting the power with the main fuse.

Replacing the 15 A charging fuse

The fuse holder for the charging fuse is located on the right side under the rear chassis cover. To replace the fuse, both the front and rear chassis covers must be removed:

- Remove the front central chassis cover. The cover is fixed in place with four plastic plugs and can be removed manually by pulling it straight up.
- Remove the main chassis cover by undoing the two knobs at the front and the rear knob. Lift off the cover, replace the charging fuse and refit the covers in reverse order.

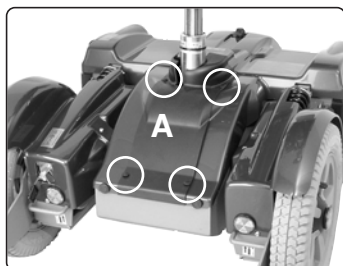

Remove the front center cover (A)

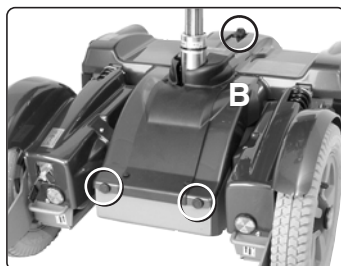

Remove the main chassis cover (B)



The charging fuse is located under the rear chassis cover

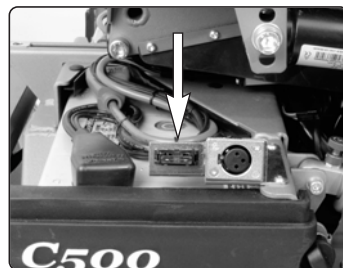

15 A charging fuse

⚠ WARNING

Always switch off the power supply to the control panel before changing the charging fuse. The battery charger must not be connected when the charging fuse is being changed.

If the charging fuse is triggered, there may be problems or faults with batteries, the charger/charging cables or the wheelchair's charging socket.

The cause of the charging fuse being triggered should be checked carefully before the fuse is changed.

Technical Specifications

The specifications given in the following pages are only applicable to the Permobil C500 chassis with Corpus Seat.

For size and weight information about each seat, see the Owner's Manual accompanying the seat.

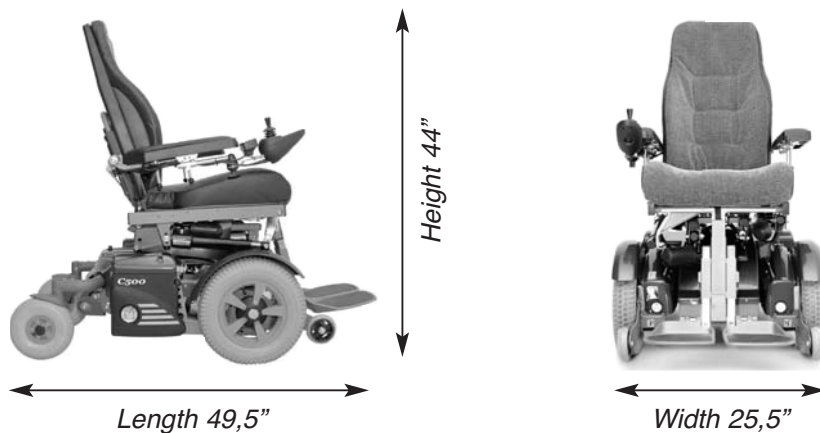

Smallest transportation size = length 37,5", width 25,5", height 33"

DATA

General

Name Permobil C500/C500 Lowrider

Size and weight

Length.....49,5"
 Width.....25,5"
 Height C50052,5"
 Height C500 Lowrider47,5"
 Smallest Transport Size, lwxh C50037,5x25,5x33"
 Smallest Transport Size, lwxh C500 Lowrider37,5x25,5x32"
 Weight incl. Batteries and Corpus-Seat350 lbs
 Max. Battery Size10,25x6,75x8,25"

Wheels

Tire Size, front.....300 x 8
 Tire Size, back210 x 65
 Max Air Pressure, front/back tires29 psi (200 kPa)

Performance

Range19 - 25 miles
 Minimum Turning Radius28"
 Ability to Negotiate Obstacles3"
 Hill Climbing Capability, uphill12 degrees
 Hill Climbing Capability, downhill12 degrees
 Safe slope.....6 degrees
 Sideways Slope Capability10 degrees

Max Speed Forward	C500	C500s
	5 mph	7,5 mph
Max Speed Backward, approx.....	2,5 mph	2,5 mph

ELECTRICAL SYSTEM R-net

Electronics, C500/C500sPM80/PM120

Control panelJSM-L-SV

Batteries

Recommended battery type...Group 24, Gel

Battery capacity2 x 73 Ah

Charging time9 hours

Fuses.....**C500/C500s**

Switch63 A/80 A

Fuse15 A/15 A

Control force

Joystick1.5 Nm

Keys2.0 Nm

Troubleshooting guide

The following troubleshooting guide describes a number of faults and events which may occur when you use your wheelchair, together with suggested remedies. Note that this guide cannot describe all the problems and events which may occur and you should always contact your service contact or Permobil in case of doubt.

EVENT	POSSIBLE CAUSE	REMEDY
The wheelchair cannot be started.	Batteries discharged.	Charge the batteries.
	The cable connection to the control panel has come loose.	Insert the cable in the control panel.
	Main fuse switched to OFF position after, for example, battery replacement.	Reset the main fuse. See page 68.
	Main fuse triggered.	See page 68.
The wheelchair cannot be driven.	Battery charger connected.	Stop charging and disconnect the charging cable from the wheelchair’s charging socket.
	Brake release activated.	Reset the brake release.
	Wheelchair locked with the security key.	Unlock the wheelchair. See page 38.
The wheelchair “switches itself off” after a certain period of inactivity (20-30 min.).	The electronics’ energy-saving mode has been activated.	Switch the wheelchair on again using the start key on the control panel.
The wheelchair stops while being driven.	The cable connection to the control panel has come loose.	Insert the cable in the control panel.
	Main fuse triggered.	See page 68.

EVENT	POSSIBLE CAUSE	REMEDY
<p>The wheelchair can only be driven at reduced speed. <i>Applies with an electric seat lift and seat angle.</i></p>	<p>Seat lift or seat angle raised too high.</p>	<p>Lower the seat lift or seat angle. See page 25.</p>
<p>The wheelchair cannot be charged.</p>	<p>Main fuse switched to OFF position after, for example, battery replacement.</p> <hr/> <p>Charging fuse triggered, for example on account of a fault in the batteries, charger, charging cables or charging socket.</p>	<p>Reset the main fuse. See page 68.</p> <hr/> <p>Check possible causes carefully before changing the charging fuse. See page 69.</p>

R-net diagnostics

When an error or a fault occurs in the wheelchair's electronics, information on it is displayed in the control panel's display. This information can then be used to diagnose where the error/fault occurred and its cause.

Troubleshooting and repairs must always be performed by competent personnel with good knowledge of the wheelchair's electronics. More information on troubleshooting and remedies can be found in the Service Manual for this wheelchair model.

Diagnostic screens

Current diagnostic screen

When the control system's integrated protection circuits have been triggered so that the control system can no longer operate the wheelchair, a diagnostic screen is displayed in the control panel's display.

This indicates a system fault, i.e. R-net has detected a problem somewhere in the wheelchair's electrical system.

NB! *If the fault is in a module that is not currently being used, it may still be possible to drive the wheelchair, but the diagnostic screen is displayed occasionally.*

Switch off the wheelchair and leave it off for a few minutes. Then restart the wheelchair. If the fault persists, you must switch off the wheelchair and contact your service contact. Write down the information displayed in plain text in the control panel's display and pass it on to your service contact.

Do not use the wheelchair until the problem has been remedied or you have received other instructions from your service contact.

WARNING

Diagnostics should only be performed by persons with sound knowledge of the wheelchair's electronic control system. Incorrect or poorly performed repair works may make it dangerous to use the wheelchair. Permobil accepts no liability for any personal injury or damage to the wheelchair and its surroundings that occurs on account of incorrect or poorly performed repair work.

NOTE

If any part is replaced without Permobil's approval, the wheelchair's warranty lapses. Permobil accepts no liability for any loss that occurs as a result of a component of the R-net control system being opened, adjusted or modified without permission.

Example of a screen showing a system fault

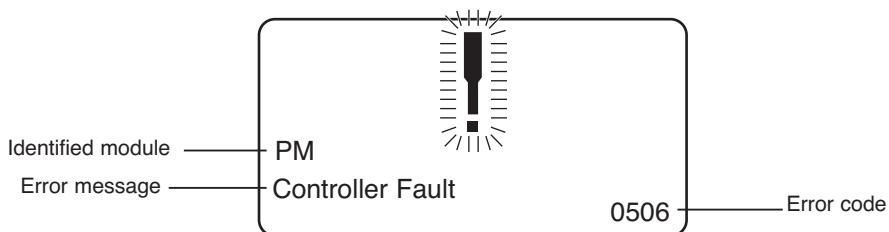

Identified module

This indicates the control system module that detected the problem.

PM= Power module

JSM= Joystick module

Error message

The error message provides a brief description of the error type.

Error code

The four-digit code indicates which protection circuit has been triggered.

Repair of defective units

Apart from specific OEM-approved spare parts (contact Permobil for further information on these), there are no replaceable parts in the R-net control system. Consequently, defective units must be sent to Permobil or a Permobil-approved repairer for repair.

Accessories

Accessories for Permobil power wheelchairs are subject to continuous development. Contact your nearest Permobil dealer for more information on the accessories available for your wheelchair.

**WARNING**

It is very important that you read this information regarding the possible effects of Electromagnetic Interference on your powered wheelchair.

Electromagnetic Interference (EMI) From Radio Wave Sources

Powered wheelchairs and motorized scooters (in this text, both will be referred to as powered wheelchairs) may be susceptible to electromagnetic interference (EMI), which is interfering electromagnetic energy (EM) emitted from sources such as radio stations, TV stations, amateur radio (HAM) transmitters, two-way radios, and cellular phones.

The interference (from radio wave sources) can cause the powered wheelchair to release its parking brakes, move by itself, or move in unintended directions. It can also permanently damage the powered wheelchair's control system. The intensity of the interfering EM energy can be measured in volts per meter (V/m). Each powered wheelchair can resist EMI up to a certain intensity. This is called its "immunity level". The higher the immunity level, the greater the protection.

The immunity level of this powered wheelchair model as shipped, with no further modification, is 20V/m in the range of 26 MHz to 1000 MHz.

There are a number of sources of relatively intense electromagnetic fields in the everyday environment. Some of these sources are obvious and easy to avoid. Others are not apparent and exposure is unavoidable. However, we believe that by following the warnings listed below, your risk to EMI will be minimized.

The sources of radiated EMI can be broadly classified into three types:

1. HAND-HELD PORTABLE TRANSCEIVERS (transmitters-receivers) with the antenna mounted directly on the transmitting unit. Examples include: citizens band (CB) radios, "walkie talkie", security, fire, and police transceivers, cellular telephones, and other personal communication devices.

NOTE! Some cellular telephones and similar devices transmit signals while they are ON, even when not being used.

2. MEDIUM-RANGE MOBILE TRANSCEIVERS such as those used in police cars, fire trucks, ambulances, and taxis. These usually have the antenna mounted on the outside of the vehicle.

3. LONG-RANGE TRANSMITTERS AND TRANSCEIVERS such as commercial broadcast transmitter (radio and TV broadcast antenna tower) and amateur (HAM) radios.

NOTE! Other types of hand-held devices, such as cordless phones, laptop computers, AM/FM radios, TV sets, CD players, and cassette players, and small appliances, such as electric shavers and hair dryers, so far we know, are not likely to cause EMI problems to your powered wheelchair.

Because EM energy rapidly becomes more intense as one moves closer to the transmitting antenna (source), the EM fields from hand-held radio wave sources (transceivers) are of special concern. It is possible to unintentionally bring high levels of EM energy very close to the powered wheelchair's control system while using these devices. This can affect powered wheelchair movement and braking. Therefore, the warnings listed below are recommended to prevent possible interference with the control system of the powered wheelchair.

WARNINGS

Electromagnetic interference (EMI) from sources such as radio and TV stations, amateur radio (HAM) transmitters, two-way radios, and cellular phones can affect powered wheelchairs and motorized scooters. Following the warnings listed below should reduced the chance of unintended wheel lock release or powered wheelchair movement which could result in serious injury.

- Do not operate hand-held transceivers (transmitters/receivers), such as citizens band (CB) radios, or turn ON personal communications devices, such as cellular phones, while the powered wheelchair is turned ON.
- Be aware of nearby transmitters, such as radio or TV stations, and try to avoid coming close to them.
- If unintended movement or wheel lock release occurs, turn the powered wheelchair OFF as soon as it is safe.
- Be aware that adding accessories or components, or modifying the powered wheelchair, may make it more susceptible to EMI.

NOTE! There is no easy way to evaluate their effect on the overall immunity of the powered wheelchair).

- Report all incidents of unintended movement or wheel lock release to the powered wheelchair manufacturer, and note whether there is a radio wave source near by.

US

C500

Permobil C500



Article no.: 205226-US-0