

Invacare® STORM⁴ MAX SERVICE MANUAL



Edition: 16.11.11



These instructions contain information about:

Testing work

Repair Instructions

This manual is part of the instructions for use.

Service addresses

A	Invacare Austria GmbH	☎:	+43 6232 5 53 50
	Herzog Odilostrasse 101	Fax:	+43 6232 5 53 54
	A-5310 Mondsee	@:	info@invacare-austria.com
	Austria	WWW:	www.invacare.at

B	Invacare n.v.	☎:	+32 (0)50 83 10 10
	Autobaan 22	Fax:	+32 (0)50 83 10 11
L	B-8210 Loppem (Brugge)	@:	belgium@invacare.com
	Belgium	WWW:	www.invacare.be

CH	Invacare AG	☎:	+41 (0)61487 70 80
	Benkenstraße 260	Fax:	+41 (0)61487 70 81
	CH-4108 Witterswil	@:	switzerland@invacare.com
	Switzerland	WWW:	www.invacare.ch

D	Invacare Aquatec GmbH	☎	+49 (0)7562 70 00
	Alemannenstraße 10	Fax	+49 (0)7562 7 00 66
	88316 Isny	@:	info@invacare-aquatec.com
	Deutschland	WWW:	www.invacare-aquatec.de

DK	Invacare A/S	☎ (Kundeservice):	+45 (0)36 90 00 00
	Sdr. Ringvej 37	Fax (Kundeservice):	+45 (0)36 90 00 01
	DK-2605 Brøndby	@:	denmark@invacare.com
	Danmark	WWW:	www.invacare.dk

E	Invacare® SA	☎:	+34 (0)972 49 32 00
	c/ Areny s/n	Fax:	+34 (0)972 49 32 20
	Polígon Industrial de Celrà	@:	contactsp@invacare.com
	E-17460 Celrà (Girona)	WWW:	www.invacare.es
ESPAÑA			

F	Invacare® Poirier SAS	☎:	+33 (0)247 62 64 66
	Route de St Roch	Fax:	+33 (0)247 42 12 24
	F-37230 Fondettes	@:	contactfr@invacare.com
	France	WWW:	www.invacare.fr

GB	Invacare® Ltd Pencoed Technology Park Pencoed Bridgend CF35 5HZ United Kingdom	☎ (Customer services): +44 (0)1656 77 62 22 Fax (Customer services): +44 (0)1656 77 62 20 @: uk@invacare.com WWW: www.invacare.co.uk
I	Invacare Mecc San s.r.l. Via dei Pini, 62 I - 36016 Thiene (VI) Italia	☎: +39 0445 38 00 59 Fax: +39 0445 38 00 34 @: italia@invacare.com WWW: www.invacare.it
IE	Invacare Ireland Ltd. Unit 5 Seatown Business Campus Seatown Rd, Swords County Dublin Ireland	☎: +353 18 10 70 84 Fax: +353 18 10 70 85 @: ireland@invacare.com WWW: www.invacare.ie
N	Invacare® AS Grensesvingen 9 Postboks 6230 Etterstad N-0603 Oslo Norge	☎ (Kundeservice): +47 (0)22 57 95 00 Fax (Kundeservice): +47 (0)22 57 95 01 @: norway@invacare.com @: island@invacare.com WWW: www.invacare.no
NL	Invacare® B.V. Celsiusstraat 46 NL-6716 BZ Ede Nederland	☎: +31 (0)318 69 57 57 Fax: +31 (0)318 69 57 58 @: nederland@invacare.com @: csede@invacare.com WWW: www.invacare.nl
P	Invacare Lda Rua Estrada Velha, 949 P-4465-784 Leça do Balio Portugal	☎: +351 225 10 59 46 ☎: +351 225 10 59 47 Fax: +351 225 10 57 39 @: portugal@invacare.com WWW: www.invacare.pt

**Återförsäljare:**

Invacare® AB



Fagerstagatan 9

S-163 91 Spånga

Sverige

☎ (Kundtjänst): +46 (0)8 761 70 90

Fax (Kundtjänst): +46 (0)8 761 81 08

@: sweden@invacare.com

@: finland@invacare.com

WWW: www.invacare.se

Tillverkare:

Invacare® Deutschland GmbH

Kleiststraße 49

D-32457 Porta Westfalica

Deutschland

MÖLNDAL

☎☐: +46 (0)31 86 36 00

Fax: +46 (0)31 86 36 06

@: ginvacare@invacare.com

LANDSKRONA

☐☎: +46 (0)418 2 85 40

Fax: +46 (0)418 1 80 89

@: linvacare@invacare.com

OSKARSHAMN

☐☎: +46 (0)491 1 01 40

Fax: +46 (0)491 1 01 80

@: oinvacare@invacare.com

**Eastern
european
countries****European Distributor
Organisation (EDO)**

Kleiststraße 49

D-32457 Porta Westfalica

Deutschland

☎ +49 (0)5731 75 45 40

Fax +49 (0)5731 75 45 41

@: edo@invacare.com

WWW: www.invacare.de

Contents

Chapter		Page
1	Introduction	8
1.1	General information	8
1.2	Notes on transport	8
1.3	Definition and representation of information and safety information in this manual.....	9
1.4	Hazard symbols and symbols used	10
1.5	Images in this manual	11
2	Safety and fitting instructions	12
2.1	Before any inspection or repair work.....	12
2.2	Personal safety equipment.....	12
2.3	General safety information and information about fitting / removal.....	12
3	Tightening torques	15
4	Layout of components and componentry	16
4.1	Overview.....	16
4.2	Electronics modules	17
4.2.1	ACS 2 PMA90L electronics module	18
4.2.2	ACT actuator module.....	18
4.2.2.1	ACT 2 actuator module.....	18
4.2.2.2	ACT 4 actuator module.....	18
4.2.3	Lighting PCB.....	19
4.3	Joystick boxes.....	20
5	Service plan (1x annually)	22
6	Operational faults	25
6.1	Drive fault diagnosis	26
6.2	REM remotes: Error codes and diagnostic codes	31
6.3	Diagnosis of charging device faults.....	32
7	Repair work	33
7.1	Covers.....	33
7.1.1	Opening the rear cover panel.....	33
7.1.2	Opening the centre panel	34
7.1.3	Opening the front panel	36
7.1.4	Opening the rear light cover	37
7.1.5	Replacing the splash guard	38

7.2	Lighting unit	39
7.2.1	Replacing the front LED (LED lighting unit).....	39
7.2.2	Replacing the complete front headlight (LED lighting unit).....	39
7.2.3	Replacing the front bulb holder (LED lighting unit).....	41
7.2.4	Replacing the complete rear light (LED lighting unit).....	42
7.2.5	Replacing the rear bulb holder (LED lighting unit).....	43
7.3	Batteries, cables & battery charger	44
7.3.1	Making the batteries accessible.....	44
7.3.2	Replacing batteries.....	46
7.3.3	Correct handling of damaged batteries.....	48
7.3.4	Checking and replacing the main fuse.....	49
7.3.5	Checking the cable.....	51
7.3.6	Cable routing.....	52
7.4	Electronics module	53
7.4.1	Replace remote.....	53
7.4.2	Replacing the power module.....	53
7.4.3	Replacing the actuator module under the seat.....	56
7.4.4	Replacing the lighting PCB.....	57
7.4.5	Replacing the G-Trac sensor.....	59
7.4.6	Drive program selection after component replacement.....	61
7.4.6.1	Profile selection with remote REM A or REM B.....	61
7.4.6.2	Profile selection with remote REM 550.....	62
7.5	Updating the driving program	63
7.6	Seat support and tilt module	64
7.6.1	Replacing the seat support with manual tilt module (till Dec. 2010).....	64
7.6.2	Adjusting the seat tilt on a seat with a manual tilt module (till Dec. 2010).....	66
7.6.3	Replacing the seat frame with a manual tilt module (from Dec. 2010).....	67
7.6.4	Adjusting the seat tilt on a seat with a manual tilt module (from Dec. 2010).....	69
7.6.5	Replacing the seat support with electric tilt module.....	70
7.6.6	Replacing the tilt actuator.....	72
7.7	Lifting column	73
7.8	Seat height adjustment	75
7.8.1	Adjusting the seat height with a manual lifter pillar.....	75
7.9	Replacing the safety belt	77
7.10	Seat support	78
7.10.1	Adjusting the seat width.....	78
7.10.2	Adjusting the seat depth.....	80
7.11	Back unit	82
7.11.1	Adjusting the belt back.....	82
7.11.2	Adjusting a sling backrest.....	83

7.11.3	Replacing the cross braces	84
7.11.4	Replacing a standard backrest	85
7.12	Fitting the headrest	86
7.12.1	Fitting the headrest to the standard back	86
7.13	Installing armrests.....	87
7.14	Installing a footrest	89
7.15	Installing calf supports	90
7.16	Replacing the front wheel carrier	91
7.16.1	Replacing the front wheel carrier.....	91
7.17	Front wheel forks	93
7.17.1	Replacing the wheel fork	93
7.17.2	Adjusting the wheel fork	95
7.17.3	Changing a front wheel.....	96
7.17.4	Replacing a tire or inner tube in the front	97
7.18	Drive wheels.....	99
7.18.1	Replacing the drive wheel	99
7.18.2	Replacing a tyre or inner tube	100
7.18.2.1	Replacing pneumatic tyres	100
7.18.2.2	Replacing puncture-protected tyres	102
7.18.2.3	Replacing puncture-proof tyres	104
7.18.3	Replacing the drive wheel hub	105
7.19	Drive unit	106
7.19.1	Replacing the motor/transmission unit (Standard Storm ⁴)	106
7.19.2	Replacing the carbon brushes (Standard motor)	108
7.19.3	Replacing Bowden cables and the clutch.....	110
7.20	Rear wheel suspension	113
7.20.1	Replacing the rear wheel suspension	113
7.21	Replacing the strut.....	115
7.21.1	Removing the suspension strut	115

1 Introduction

1.1 General information

- Service and maintenance work must be carried out taking this service manual into account.
- It is imperative that you observe safety information.
- Information about operation or about general maintenance and care work on the mobility aid should be taken from the operating manual.
- You can find information about ordering spare parts in the spare parts catalogue.
- Only use original Invacare® spare parts. The guarantee will become invalid if other spare parts are used!
- We reserve the right to make any alterations on the grounds of technical improvements.
- The mobility aid may only be maintained and overhauled by qualified personnel.
- The minimum requirement for service technicians is suitable training, such as in the cycle or orthopaedic mechanics fields, or sufficiently long-term job experience.
 - Experience in the use of electrical measuring equipment (multimeters) is also a requirement.
 - Special Invacare® training is recommended.
- Alterations to the mobility aid which occur as a result of incorrectly or improperly executed maintenance or overhaul work lead to the exclusion of all liability on the side of INVACARE.
- If you have any problems or questions please contact Invacare® Service.

1.2 Notes on transport

- If the mobility aid has to be shipped back to the manufacturer for major repairs, you should always use the original packaging for transport.
- Please attach a precise description of the fault.

1.3 Definition and representation of information and safety information in this manual

Different types of information and signal words are used throughout this manual.



HAZARD!

The signal word "HAZARD!" refers to immediate hazards.

- *The following lines in italics refer to actions which serve to avoid such hazards.*
-



WARNING!

The signal word "WARNING!" refers to possibly-occurring hazards which can lead to death or serious injuries if they are not avoided.

- *The following lines in italics refer to actions which serve to avoid such hazards.*
-



ATTENTION!

The signal word "ATTENTION!" refers to possibly-occurring hazards which can lead to minor injuries and/or material damage if they are not avoided.

- *The following lines in italics refer to actions which serve to avoid such hazards.*
-



CAUTION!

The signal word "CAUTION!" refers to hazards which could lead to material damage if they are not avoided.

- *The following lines in italics refer to actions which serve to avoid such hazards.*
-



Note

The signal word "Note" is used to denote general information which simplifies the handling of your product and refers to special functions.

1.4 Hazard symbols and symbols used

Different types of hazard symbols and symbols are used throughout this manual.



General hazards

This symbol warns you of general hazards!

- Always follow the instructions to avoid injury to the user or damage to the product!



BURN HAZARD!

This symbol warns you of the danger of chemical burns, for example due to the discharge of battery acids!

- Always follow the instructions to avoid injury to the user or damage to the product!



DANGER OF CRUSHING!

This symbol warns you of crushing hazards due to inattentive working with heavy components.

- Always follow the instructions to avoid injury to the user or damage to the product!



EXPLOSION HAZARD!

This symbol warns you of an explosion hazard, which can be caused by excessive tyre pressure in a pneumatic tyre.

- Always follow the instructions to avoid injury to the user or damage to the product!



Wear safety shoes

The symbol refers to the requirement for wearing safety shoes.

- Wear standardised safety shoes during all work.



Wear eye protection

This symbol refers to the requirement for wearing eye protection, for example when working with batteries.

- Wear eye protection when this symbol is shown.



Wear safety gloves

This symbol refers to the requirement for wearing safety gloves, for example when working with batteries.

- Wear safety gloves when this symbol is shown.



Note

This symbol identifies general information which is intended to simplify working with your product and which refers to special functions.



Requirements:

- This symbol identifies a list of various tools, components and items which you will need in order to carry out certain work. Please do not attempt to carry out the work if you do not have the listed tools available.



Always dispose used or damaged batteries correctly

The symbol refers to information for the correct disposal of used or damaged batteries.

1.5 Images in this manual

The detailed images in this manual are given digits to identify various components. Component numbers in text and operational instructions always relate to the image directly above.

2 Safety and fitting instructions

These safety instructions are intended to prevent accidents at work, and it is imperative that they are observed.

2.1 Before any inspection or repair work

- Read and observe this repair manual and the associated operating manual!
- Observe the minimum requirements for carrying out the work (see chapter entitled " General information)!

2.2 Personal safety equipment



Safety shoes

The mobility device, and some of its components, are very heavy. These parts can result in injuries to the feet if they are allowed to drop.

- *Wear standardised safety shoes during all work.*



Eye protection

It is possible that battery acid can be discharged when working on defective batteries or when handling batteries improperly.

- *Always wear eye protection when working on any defective or possibly defective batteries.*



Safety gloves

It is possible that battery acid can be discharged when working on defective batteries or when handling batteries improperly.

- *Always wear acid-proof safety gloves when working on any defective or possibly defective batteries.*

2.3 General safety information and information about fitting / removal



WARNING: Danger of crushing!

Various components such as the drive unit, batteries, seat etc are very heavy. This results in injury hazards to your hands!

- *Please note the high weight of some components! This applies especially to the removal of drive units, batteries and the seat.*



WARNING!

Injury hazard if the vehicle starts moving unintentionally during repair work!

- *Switch the power supply off (ON/OFF key)!*
- *Engage the drive!*
- *Before jacking up, secure the vehicle by using chocks to block the wheels.*

**ATTENTION!****Fire and burn hazard due to electrical short-circuit!**

- *The mobility device must be completely switched off before removal of voltage-carrying components! To do this, remove the batteries.*
- *Avoid short-circuiting the contacts when carrying out measurements on voltage-carrying components!*

**CAUTION!****Danger of burns from hot surfaces on the motor!**

- *Allow the motors to cool down before commencing work on them.*

**ATTENTION!****Injury hazard and danger of damage to vehicle due to improper or incomplete maintenance work!**

- *Use only undamaged tools in good condition.*
- *Some moving parts are mounted in sockets with PTFE coating (Teflon™). Never grease these sockets!*
- *Never use "normal" nuts instead of self-locking nuts.*
- *Always use correctly-dimensioned washers and spacers*
- *When reassembling, always replace any cable ties which were cut during dismantling.*
- *After completing your work / before renewed start-up of the mobility device, check all connections for tight fitting.*
- *After completing your work / before renewed start-up of the mobility device, check all parts for correct locking.*
- *Only operate the vehicle with the approved tyre pressures (see technical data).*
- *Check all electrical components for correct function. Please note that incorrect polarity can result in damage to the electronics.*
- *Always carry out a trial run at the end of your work.*

**CAUTION!****Danger of injury and damage to property, if the maximum speed reduction on a wheelchair with a lifter does not function correctly!****The wheelchair's control unit must reduce the maximum possible speed as soon as the lifter is raised.**

- *Test the maximum speed reduction for correct function after any maintenance work or modifications to the wheelchair.*

**Note**

Mark all current settings for the mobility aid (seat, armrests, backrest etc.), and the associated cable connecting plugs, before dismantling. This makes reassembly easier. All plugs are fitted with mechanical safety devices which prevent release of the connecting plugs during operation. To release the connecting plugs the safety devices must be pressed in. When reassembling ensure that these safety devices are correctly engaged.

**CAUTION!**

Any changes to the drive program can affect the driving characteristics and the tipping stability of the vehicle!

- *Changes to the drive program may only be carried out by trained Invacare® specialist dealers!*
 - *Invacare® supplies all mobility aids with a standard drive program ex-works. Invacare® can only give a warranty for safe vehicle driving behaviour - especially tipping stability - for this standard drive program!*
-

3 Tightening torques

The tightening torques stated in the following list are based on the thread diameter for the nuts and bolts for which no specific values have been determined. All values assume dry and de-greased threads.

Thread	M4	M5	M6	M8	M10	M12	M14	M16
Tightening torque in Nm $\pm 10\%$	3 Nm	6 Nm	10 Nm	25 Nm	49 Nm	80 Nm	120 Nm	180 Nm

**CAUTION!**

Damage can be caused to the mobility device due to improperly tightened screws, nuts or plastic connections.

- *Always tighten screws, nuts etc to the stated tightening torque.*
- *Only tighten screws or nuts which are not listed here fingertight.*

4 Layout of components and componentry

4.1 Overview

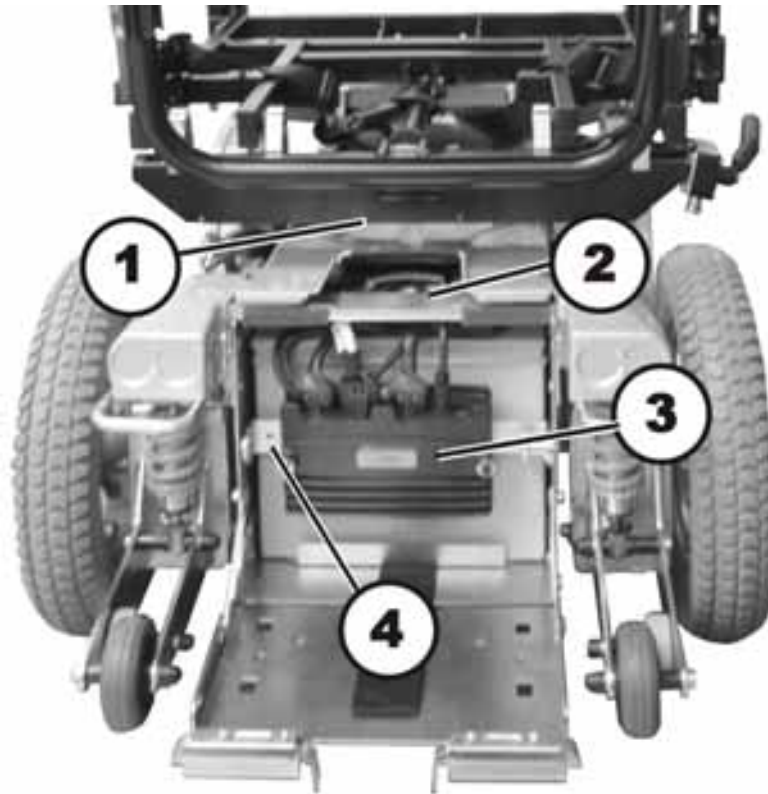

The electronic control modules and regulators are situated at the rear underneath the rear plastic cover and directly under the seat.

Directly under the seat:

- Actuator module (1)
The actuator module is optional. If present, it controls the electrical tilt module as well as the electrical backrest adjustment.





Under the rear cowling:

- Light terminal module (2)
The lighting distributor module is located on top of the battery box. The lighting distributor module is optional. It is only present if the wheelchair is equipped with a lighting system.
- Power module (3)
The power module is located in the rear inside of the battery box.
- G-Trac (4)
The G-Trac sensor is located inside of the battery box directly next to the power module.
-

4.2 Electronics modules

A variety of electronics modules can be fitted to the mobility aid.

Before you connect mobility aid components such as adjusting motors/actuators or motors, please begin by ascertaining which module is installed. Please refer to the following table for an overview.

Electronic module	Designation	Notes
	Power module ACS 2 PMA90L	The following remotes can be connected: - REM 24 SD - REM A - REM B - REM 550
	Actuator module ACT 2 / ACT 4	The actuator module is optional.
	Lighting PCB	The lighting PCB is optional.
	G-Trac sensor	The G-Trac sensor is optional

4.2.1 ACS 2 PMA90L electronics module

Connections

- 1) Battery 24V
- 2) Cable to G-Trac module (GYRO)
- 3) Bus cable (to remote or ACT)
- 4) Motor M1
- 5) Light
- 6) Motor M2

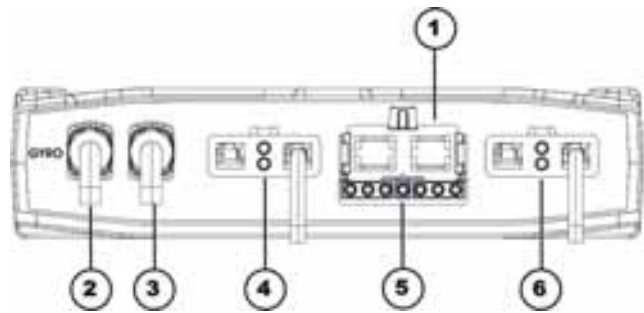

4.2.2 ACT actuator module

A range of adjusting motors, also known as actuators, can be fitted to the mobility aid. These actuators are either connected directly to the power module or to a separate actuator module. The actuator module is connected to the power module via a bus cable.

4.2.2.1 ACT 2 actuator module

Connections

- 1) ACI*
- 2) Bus cable (to remote or ACT)
- 3) Bus cable (to remote or ACT)
- 4) Adjusting motor/actuator - Channel 2
- 5) Adjusting motor/actuator - Channel 1

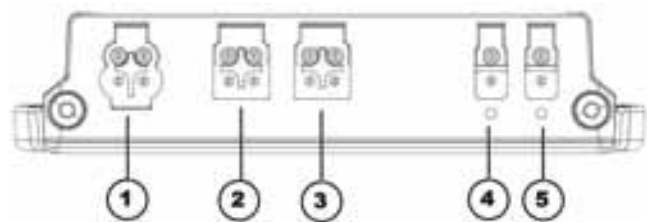

* The ACI connection is used for actuator limitation or speed reduction.

4.2.2.2 ACT 4 actuator module

Connections

- 1) ACI*
- 2) Bus cable
(to remote or power module)
- 3) Bus cable
(to remote or power module)
- 4) Actuator - Channel 4
- 5) Actuator - Channel 3
- 6) Actuator - Channel 2
- 7) Actuator - Channel 1

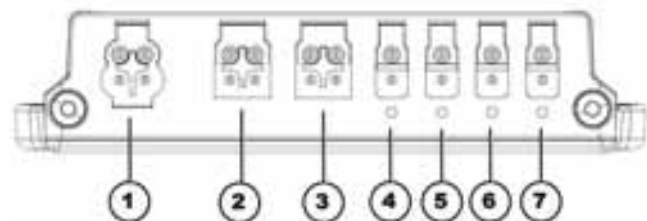

* The ACI connection is used for actuator limitation or speed reduction.

4.2.3 Lighting PCB

Connections

- 1) Driving light & l.h. indicator 1
- 2) Driving light & l.h. indicator 2
- 3) Power module
- 4) Driving light & r.h. indicator 1
- 5) Driving light & r.h. indicator 2

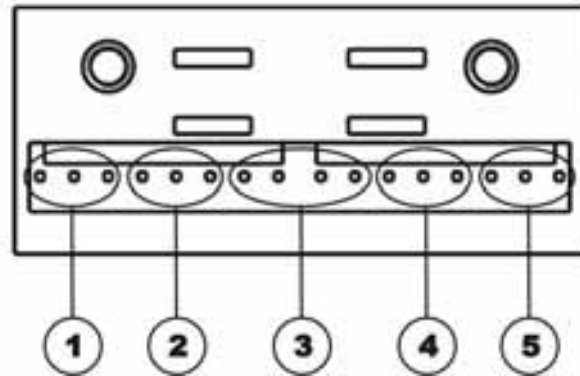



The lighting PCB connections are printed directly on the circuit board.

4.3 Joystick boxes

Various remotes can be used on the mobility aid.

Before you connect any mobility aid components such as adjusting motors/actuators or motors, you should first ensure that you know exactly which joystick box has been fitted. Please refer to the following table for an overview.

Remote	Designation	Notes
 <p>The image shows a black remote control with a large joystick at the bottom. Above the joystick is a grid of buttons with various icons: a key, a power button, a left arrow, a right arrow, and a warning triangle. There are also some smaller buttons at the top.</p>	<p>REM 24 SD</p>	<p>Can be connected to power module - ACS 2 PMA90L.</p>
 <p>The image shows a black remote control with a joystick at the bottom. Above the joystick is a cluster of buttons with directional arrows (up, down, left, right) and a central button. There are also some smaller buttons at the top.</p>	<p>REM A</p>	<p>Can be connected to power module - ACS 2 PMA90L.</p>

Remote	Designation	Notes
	<p>REM B</p>	<p>Can be connected to power module - ACS 2 PMA90L.</p>
	<p>REM 550</p>	<p>Can be connected to power module - ACS 2 PMA90L.</p>

5 Service plan (1x annually)

Component	Check	Remedy	Notes	✓
Safety belt	Damage to safety belt	Replace belt if damaged.	See chapter 7.9.	
	Belt lock function	Replace belt if damaged.	See chapter 7.9.	
Armrests	Damage to armrests	Replace covering if damaged		
	Armrest fixings	Tighten screws		
Side panels	Damage to side panels	Replace side panels if damaged		
	Side panel fixings	Tighten screws		
Seat angle adjustment	Tight fit of the bolt retainer clips	If necessary, replace the bolt retainer clips		
Lifter	Check screws	Tighten screws		
Power backrest (if fitted)	Damage to backrest Seams Fixing Check cable Check function	Replace parts if damaged Tighten screws Replace cable motor if necessary		
Frames (chassis) / battery mounting	Carry out a visual check of the fasteners, rivets and battery receptacle	Tighten screws Replace components if necessary		

Component	Check	Remedy	Notes	✓
Wheel suspension and wheels	Check drive wheels for tight fit and side play	Adjust, replace wheel hubs	See chapters 7.18.1 and 7.18.3.	
	Check steering wheels for tight fit, float and side play	Replace wheels, wheel fork or wheel bearings	See chapter 7.17.	
	Tyres	Repair or replace if damaged	See chapter 7.18.2.	
	Check suspension	Repair or replace if damaged	See chapter 7.21.	
	Check straight running	Replace wheels, wheel fork or wheel bearings	See chapter 7.17.	
Drive units, clutch mechanism	Motors	Check motors	See chapter 7.19.	
	Check functions during drive operation and when pushing Check the clutch mechanism	Check carbon brushes, replace if necessary Replace motor if necessary. Tighten screws/nuts, adjust or replace if necessary	See chapters 7.19.1 and 7.19.2.	
Legrests	Check welded seams, interlocking, screws, footplates	Tighten, replace if necessary		
Power legrests (if fitted)	Check cable Check contacts check functions	Replace cable if necessary		
Lighting (if fitted)	Check cable Check function	Replace lamp or cable if necessary	See chapter 7.2.	
Battery mounting	Check battery support and mounting belts for damage	Replace if necessary		

Component	Check	Remedy	Notes	✓
Batteries	Check batteries for damage	Replace batteries if necessary	See chapters 7.3.2 and 7.3.3.	
	Check battery voltage	Charge batteries		
	Check battery voltage	Charge batteries	See operating manual	
	Check contacts and terminals	Clean contacts and terminals	Please refer to the safety information in chapter 7.3.2 and 7.3.3 for handling batteries	
Remote / electronics modules	Remote, status display blinking	Evaluate error/blink code	See chapter 6.	
	Fixings	Tighten fixings, replace if necessary		
	Cables and connecting plugs	Tighten cables and connecting plugs, replace if necessary		
	Drive lever function	Replace drive lever if necessary Replace remote if necessary		
	Power supply	Tighten cables and connecting plugs, replace if necessary		
Drive program	Check drive electronics program version	Update software if newer version available.	See chapter 7.5.	

6 Operational faults

Different power modules can be installed in the mobility aid in connection with different remotes. The rectification of operational faults depends on the installed power module in each case.

The power modules used are described in chapter 4.2.



Note

The tables for rectification of operational faults listed in the following chapters are only an excerpt from the original manufacturer's manuals. You can obtain the original manuals from Invacare®.

If you have problems with the mobility aid, please proceed as follows:

- First assess the possible cause of the problem using the following table.
- Check the remote status display. Evaluate the error code.
- Carry out the necessary checks and repairs as recommended in the following table.

6.1 Drive fault diagnosis

PROBLEM	OTHER SYMPTOMS	POSSIBLE CAUSE	SOLUTION	Documentation
Mobility aid will not start	The remote status display illuminates normally and displays blink code 5/6.	Drive motors disengaged	Engage drive motors	See operating manual
	Remote status display does not illuminate	Batteries defective	Replace batteries	See chapter 7.3.2.
		Completely discharge battery	Pre-charge batteries	See instruction manual for charger
		Power supply to remote interrupted	Check master fuse	See chapter 7.3.4.
			Check cables between the modules for loose connections and damage	See chapter 7.3.5.
	Remote defective	Replace remote	See chapter 7.4.1.	
Remote status display blinking	Various causes	Assess error code	See chapter 6.2.	
Mobility aid judders in drive mode	None	Batteries defective (unstable voltage)	Replace batteries	See chapter 7.3.2.
		Drive motor(s) defective	Replace motor(s)	See chapter 7.19.1.
			Replace carbon brushes	See chapter 7.19.2.
Mobility aid pulls to left or right	None	Drive motors running asymmetrically	Change programming to synchronise motors.	See chapter 7.5.
	Tyre visibly dented	Not enough air in the tyre	Check air pressure, replace inner tube and/or valve if necessary.	See chapter 7.18.2.
Error message does not go out	None	Bad connections	Check all connecting cables.	See chapter 7.3.5.
		Motor brake defective	Measure internal resistance of brakes, replace motor if defective.	See chapter 7.19.1

PROBLEM	OTHER SYMPTOMS	POSSIBLE CAUSE	SOLUTION	Documentation
Motors stop and start again	None	Voltage decline	Stop journey and allow electronics to cool down.	
Motor runs but loses power	None	High motor load allows the power module to lower the voltage.	Stop journey and allow electronics to cool down.	
Motors stop and do not start again	None	High motor load allows the power module to lower the voltage.	Leave mobility aid switched on and let the power module operate. Charge batteries overnight with mobility aid switched on.	
	None	Fuse burnt out	Check cabling and replace fuse	See chapters 7.3.5 and 7.3.4
	None	Motor defective	Check carbon brushes and replace if necessary	See chapter 7.19.2.
			Replacing the motor	See chapter 7.19.1
	None	Power module defective	Replace power module	See chapter 7.4.2.
Motors lose power during journey	None	Bad connections	Switch mobility aid off, wait 10 seconds, switch mobility aid on again. Check all cabling.	See chapter 7.3.5.
Motor judders or runs irregularly, or only one motor runs	None	Carbon brushes worn	Check carbon brushes and replace if necessary	See chapter 7.19.2.
		Bearing defective	Replacing the motor	See chapter 7.19.1.
		Collector defective	Replacing the motor	See chapter 7.19.1

PROBLEM	OTHER SYMPTOMS	POSSIBLE CAUSE	SOLUTION	Documentation
Motors do not run	None	Bad connections	Check all cabling.	See chapter 7.3.5.
		Fuse burnt out	Check cabling and replace fuse	See chapters 7.3.5 and 7.3.4
		Batteries defective	Replace batteries	See chapter 7.3.2.
		Cabling to power module or remote defective	check cabling	See chapter 7.3.5.
		Power module defective	Replace power module	See chapter 7.4.2.
	Corroded contacts	Water, salt or urine has penetrated	Check cabling, replace if necessary.	See chapter 7.3.5.
Motor makes clicking noise	None	Bearing defective	Replacing the motor	See chapter 7.19.1.
		Collector defective	Replacing the motor	See chapter 7.19.1
Scraping noise or motor blocked	None	Bearing defective	Replacing the motor	See chapter 7.19.1.
		Transmission defective	Replace transmission.	See chapter 7.19.1.
Transmission makes clicking noise	None	Transmission defective	Replace transmission.	See chapter 7.19.1.
		Drive wheel loose	Tighten drive wheel, secure bolts with Loctite if necessary	See chapter 7.18.1.

PROBLEM	OTHER SYMPTOMS	POSSIBLE CAUSE	SOLUTION	Documentation
Transmission losing oil	None	Sealing ring on drive shaft defective	Replace transmission if sealing ring defective.	See chapter 7.19.1.
			Check carbon brushes for oil wetting, replace motor if brushes wet	See chapters 7.19.1 and 7.19.2
Irregular running	None	Drive shaft movable or bent	Check drive shaft, replace transmission if defective.	See chapter 7.19.1.
Parts lost	None	Parts lost	Reattach parts once found.	
Batteries not being charged	None	Fuse burnt out, cable defective	Check cabling and replace fuse	See chapters 7.3.5 and 7.3.4
		Batteries defective	Replace batteries	See chapter 7.3.2.
	LEDs blinking on charging unit	Charging unit defective	Replace charging unit	See instruction manual for charger
Short charging period	None	One of the batteries could be defective	Replace batteries	See chapter 7.3.2.
Mobility aid runs too slowly	None	Remote defective	Replace remote	See chapter 7.4.1.
		Batteries defective	Replace batteries	See chapter 7.3.2.

PROBLEM	OTHER SYMPTOMS	POSSIBLE CAUSE	SOLUTION	Documentation
Electrical adjustment motor does not react	Remote shows blinking "E" ¹ or blink code 2 ² Status diode on lighting/actuator module does not go out even if the remote has been switched off or disconnected	Lighting / actuator module defective	Replace lighting / actuator module	See chapter 7.4.4.
	None	Cable disconnected or damaged	Safeguard cable connection, replace cable if necessary	See chapter 7.3.5.
		Electrical adjusting motor defective	Check adjusting motor	
		Remote defective	Replace remote	See chapter 7.4.1.

1 Only applies to remote SD24
2 All remotes except SD24

6.2 REM remotes: Error codes and diagnostic codes

The drive electronics can automatically rectify some faults. In this case the status display will stop blinking. Switch the remote on and off again several times. Wait around 5 seconds each time before switching the remote on again. If this does not rectify the fault, determine the cause using the blink codes from the following table.

BLINK CODE	POSSIBLE CAUSE	SOLUTION	DOCUMENTATION
1 x blink	Module defective	Replace defective module	See chapter 7.4.2.
2 x blink	Accessory error (e.g. short-circuit in adjusting motor)	Check accessory connections, check accessory	See chapter 7.3.5.
3 x blink	Fault on left-hand motor (M2). Connection loose/defective or motor defective	Check connection plug, check motor	See chapters 7.3.5 and 7.19.1
4 x blink	Fault on right-hand motor (M1). Connection loose/defective or motor defective	Check connection plug, check motor	See chapters 7.3.5 and 7.19.1
5 x blink	Fault/brake fault on left-hand motor (M2). Connection loose/defective or motor defective	Check connection plug, check motor	See chapters 7.3.5 and 7.19.1
6 x blink	Fault/brake fault on right-hand motor (M19). Connection loose/defective or motor defective	Check connection plug, check motor	See chapters 7.3.5 and 7.19.1
7 x blink	Completely discharge battery	Pre-charge battery	See operating manual
8 x blink	Battery voltage too high	Switch lighting to low battery voltage Check battery charger	See instruction manual for charger
9 or 10 x blink	Faulty data transmission between modules	Remove electronic modules except for the power module and the remote. Replace the modules one after another in order to ensure which the one was causing the fault.	See chapter 7.4.2.
11 x blink	Drive motors overloaded / overheated	Switch remote on and off / wait if necessary	-
12 x blink	Compatibility problems between modules	Remove incorrect module	See chapter 7.4.2.

6.3 Diagnosis of charging device faults

SYMPTOM	POSSIBLE CAUSE	SOLUTION
No LEDs illuminating on battery charger	Charging device not connected to mains supply.	Ensure that the battery charger has been plugged in.
	No mains supply	Check the mains supply with a voltmeter.
	Defective mains supply cable.	Check the mains supply cable. Replace damaged cables or send the battery charger to Invacare® Service for repair.
	LEDs are burnt out	Send the battery charger to Invacare® Service for repair.
	An internal fuse might be burnt out.	Send the battery charger to Invacare® Service for repair.
Batteries do not charge	Fuse on mobility aid has burnt out.	Check mobility aid fuses. See chapter 7.3.4.
	Battery charger not connected to mobility aid.	Ensure that the battery charger has been connected to the mobility aid.
	No mains supply	Check the mains supply with a voltmeter.
	Defective mains supply cable.	Check the mains supply cable. Replace damaged cables or send the battery charger to Invacare® Service for repair.
	Battery charger could be defective.	Use a battery charger which you know is working properly to charge the batteries. Send the defective battery charger to Invacare® Service for repair.
	Battery voltage is too low to operate mobility aid.	Replace the batteries. See chapter 7.3.2.

7 Repair work

7.1 Covers

7.1.1 Opening the rear cover panel



Refitting the front cover panel:

- Loosen and remove the two knurled thumb screws (1) on the left and right side of the rear casing.
- Carefully raise the rear cover. The front part of the cover is held at the top by means of a Velcro® strip. You must also release this.

Refitting the rear cover panel:

- Refit the parts in reverse order.
- Tighten the knurled thumb screws hand-tight.

7.1.2 Opening the centre panel

**Requirements:**

- 4 mm Allen key

**Dismantling the centre panel:**

- Remove the rear cover as described in chapter 7.1.1.
- If possible, use the lifter to move the seat to the uppermost position.
- Loosen the two Allen screws (1) using a 4 mm Allen key.



- Lift the rear part of the cover carefully and remove the two spacers that are underneath the cover on the Allen screws.
- Lift off the entire cover. If the mobility aid does not have a lifter, the cover must be bent apart carefully as shown in the picture on the right.

Refitting the centre panel:

- Refit the parts in reverse order.
- Now tighten all the screws finger-tight again.

7.1.3 Opening the front panel

**Requirements:**

- 4 mm Allen key

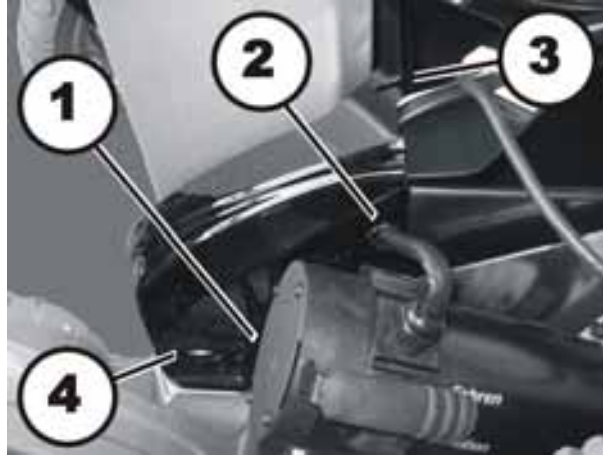
**Dismantling the front cover panel:**

- Remove the seat, as described in chapters 7.6.1 and 7.6.5.
- Remove the rear and the middle covers, as described in chapter 7.1.1 and 7.1.2.
- Loosen the two Allen screws (1) – concealed by the motor in the picture – using a 4 mm Allen key.
- Pull the motor cable and the guide bushes (2) out of the lateral recesses.
- Pull the connecting cable to the seat out of the recess (3).
- First lift the front cover up so that the retaining clips (4) are exposed.
- Then pull the cover off towards the front.

Refitting the front panel:

- Refit the parts in reverse order.
- Make sure that the retaining clips (4) snap securely into the openings of the cover.
- Now tighten all the screws finger-tight again.

7.1.4 Opening the rear light cover

**Requirements:**

- 4 mm Allen key
- socket spanner, 13 mm

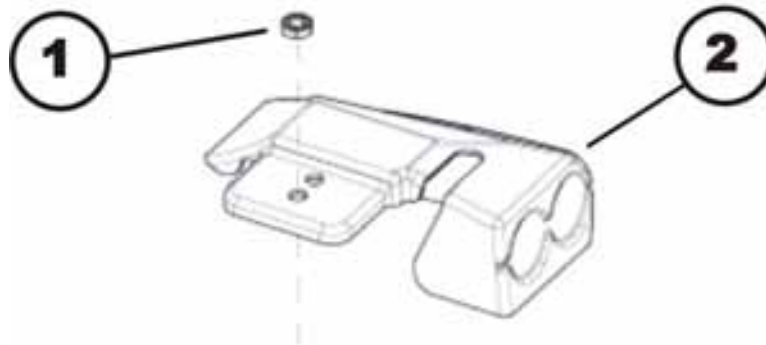
**Dismantling the rear light cover:**

- Remove the rear and centre cover as described in chapters 7.1.1 and 7.1.2.
- Loosen the nut (1) using a 13 mm socket spanner.

Refitting the rear light cover:

- Refit the parts in reverse order.
- Now tighten all the screws finger-tight again.

7.1.5 Replacing the splash guard

**Requirements:**

- 5 mm Allen key

- The following splash guards are installed on the wheelchair:
Splash guard long RH; Order Number: SP1530557
Splash guard long LH; Order Number: SP1530558

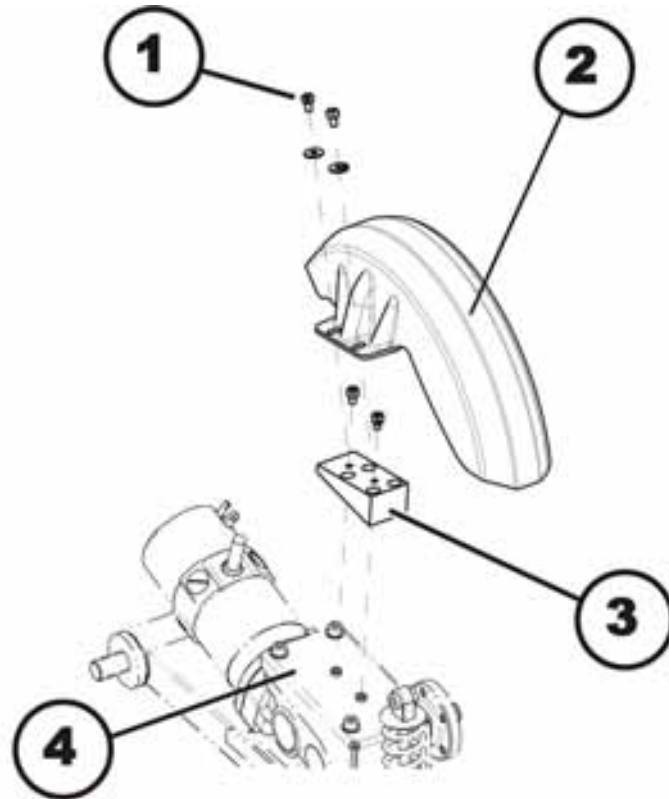
**Removing the splash guard:**

- Remove the seat.
- Loosen and remove both hexagon socket head screws (1) together with the washers.
- Remove the splash guard (2) from the gearbox holder (4).
- Pay attention to the distance wedge (3).
- Replace the splash guard according to the table (see above).

Refitting the splash guard:

- Refit the parts in reverse order.

7.2 Lighting unit

**Note**

There is only one LED lighting system.

7.2.1 Replacing the front LED (LED lighting unit)

- It is not intended for an individual LED to be replaced. Replace the entire lighting unit as described in chapter 7.2.2.

7.2.2 Replacing the complete front headlight (LED lighting unit)

**Requirements:**

- 8 mm spanner
 - 4 mm Allen key
 - Diagonal pliers
 - Cable ties
-

Removing the front headlight:

- Remove the rear and centre cover as described in chapters 7.1.1 and 7.1.2.

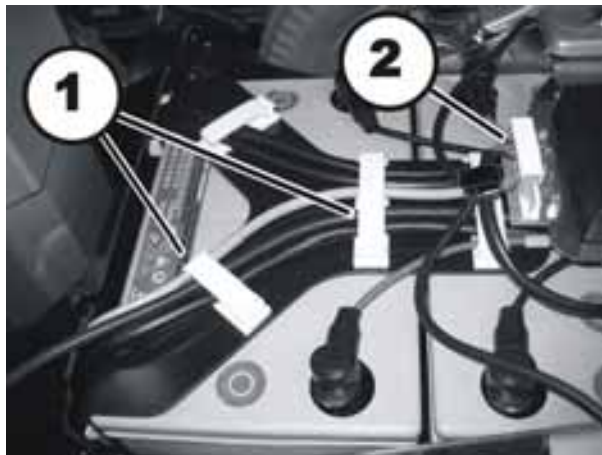

- Carefully note the location of the cable and the connection locations of the various plugs. Either mark each plug and socket, or take a photograph with a digital camera.
- Loosen the cable leading to the lighting PCB from the front headlight affected (2).
- Open the cable clamps (1), remove all cable ties and pull the cable out of the mobility aid.

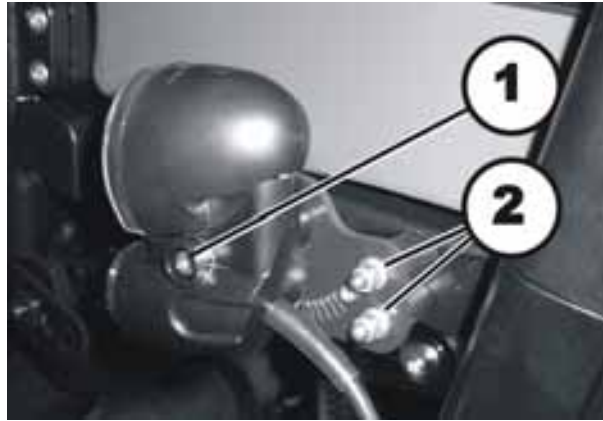

- Loosen the Allen screw (1) using a 3 mm Allen key and remove the headlight from the mounting.
- Replace the headlight unit.

Refitting the front headlight:

- Refit the parts in reverse order.
- Lay the cables carefully and fasten them using the cable clamps and cable ties. In doing so, please pay attention to chapter 7.3.6.
- Now tighten all the screws finger-tight again.
- Check all vehicle functions.
- Adjust the headlight roughly using the grid. The user can carry out the final adjustment following the operating manual.

7.2.3 Replacing the front bulb holder (LED lighting unit)

**Requirements:**

- 4 mm Allen key
- 8 mm spanner

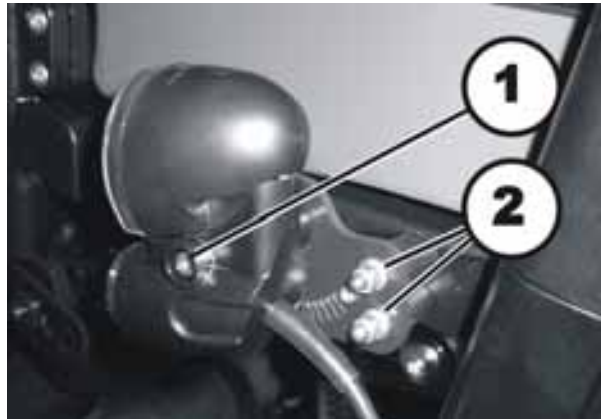
**Dismantling the bulbholder:**

- Loosen the Allen screw (1) using a 4 mm Allen key and remove the headlight from the mounting.
- Loosen the two cap nuts (2) using an 8 mm spanner and remove the headlight with the mounting from the rubber bumpers.
- Replace the mounting.

Refitting the bulbholder:

- Refit the parts in reverse order.
- Now tighten all the screws finger-tight again.
- Check all vehicle functions.
- Adjust the headlight roughly using the grid. The user can carry out the final adjustment following the operating manual.

7.2.4 Replacing the complete rear light (LED lighting unit)



Requirements:

- 4 mm Allen key
- 13 mm socket spanner

Removing the rear light

- Remove the rear and the centre cover as described in chapters 7.1.1 and 7.1.2.

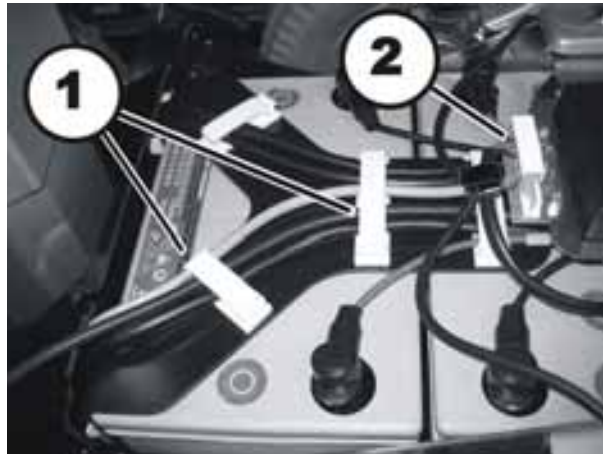

- Carefully note the location of the cable and the connection locations of the various plugs. Either mark each plug and socket, or take a photograph with a digital camera.
- Loosen the cable leading to the lighting PCB from the rear light affected (2).

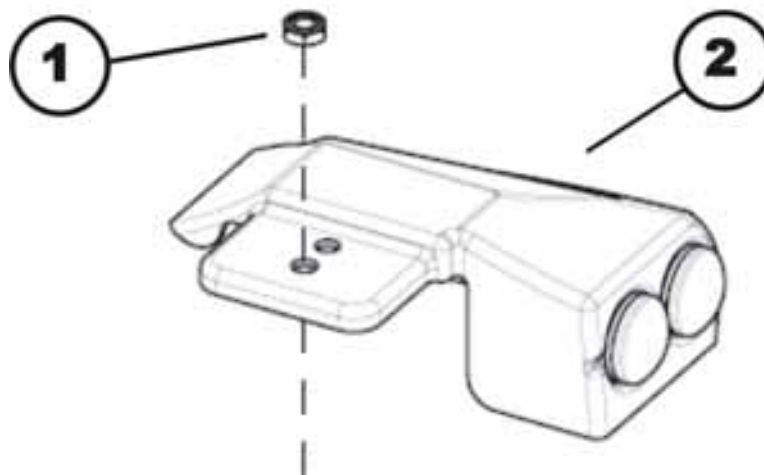

- Loosen the nut (1) with a 13 mm socket spanner.
- Lift off the plastic casing (2).



- Open the rear light plug (3) that is to be replaced.
- The rear lights are only clamped in the plastic casing. Replace the red rear light (1) or the indicator (2) as required. The cables are marked correspondingly.

Refitting the rear light:

- Refit all parts in reverse order.
- Now tighten all the screws finger-tight again.
- Check all vehicle functions.

7.2.5 Replacing the rear bulb holder (LED lighting unit)

**Requirements:**

- 4 mm Allen key
- 13 mm socket spanner

Dismantling the bulbholder:

- Remove the rear lights as described in chapter 7.2.4.
- Replacing the rear bulb holder (LED lighting unit).

Refitting the bulbholder:

- Refit all parts in reverse order.
- Check all vehicle functions.

7.3 Batteries, cables & battery charger

7.3.1 Making the batteries accessible



ATTENTION:

Injury hazard and possible material damages if batteries are handled improperly!

- *The installation of new batteries may only be carried out by authorised specialists.*
- *Observe the warning information on the batteries.*
- *Only use battery versions stated in the specifications.*



ATTENTION:

Fire and burns hazard if battery terminal is bypassed!

- *Please take great care to ensure that the battery terminals are never short-circuited with tools or mechanical mobility device parts!*
- *Ensure that the battery terminal caps have been replaced if you are not working on the battery terminals.*



ATTENTION: Danger of crushing!

The batteries are extremely heavy. This results in injury hazards to your hands.

- *Bear in mind that the batteries are sometimes very heavy!*
- *Please handle the batteries with care.*



WARNING: BURN HAZARD!

Injury hazard due to discharged acid.

- *Always wear acid-proof protective gloves when handling batteries.*
- *Always wear protective goggles when handling batteries.*



What to do if acid is discharged:

- *Always take clothing which has been soiled by or dipped in acid off immediately!*
- *Rinse any areas of your skin which has come into contact with battery acid off immediately with plenty of water!*

If contact with eyes is made:

- *Rinse the affected eye under running water for several minutes! You should also consult an eye specialist immediately afterwards!*



Requirements:

- *No tools are required.*



Note

When disassembling, take care of small parts such as screws and washers. Put all small parts down so that they can be reassembled in the right sequence.

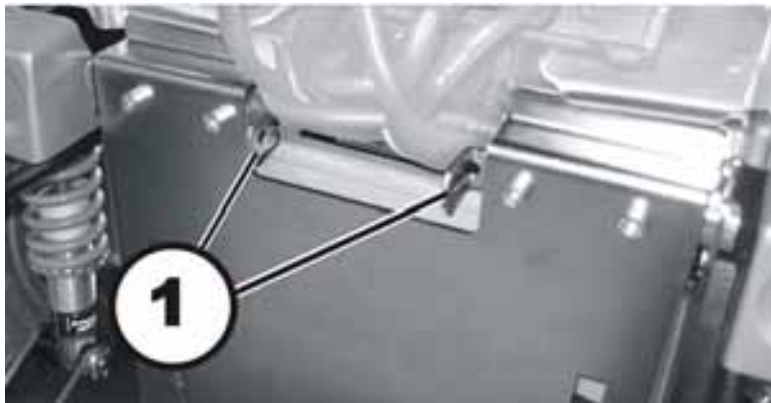

- Remove the rear panel as described in chapter 7.1.1.
- Press both catches (1) inwards and open the battery box cover.

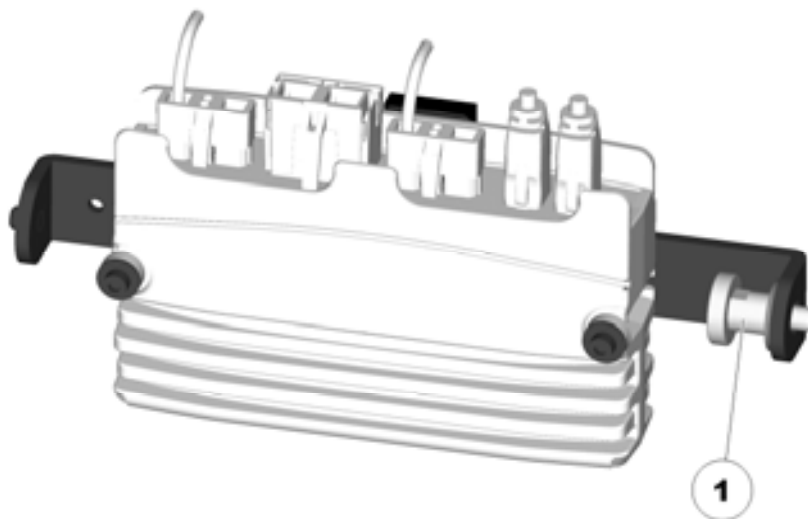

- Pull the quick-release catch (1) to the left and place the power module on top of the battery box.

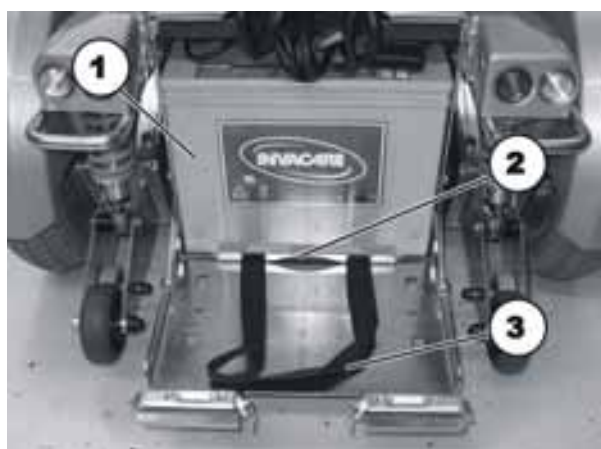

- Pull on the strap (3) to move the batteries (1) and the battery support (2) forward (see below).

7.3.2 Replacing batteries

**ATTENTION:****Injury hazard and possible material damages if batteries are handled improperly!**

- *The installation of new batteries may only be carried out by authorised specialists.*
- *Observe the warning information on the batteries.*
- *Only use battery versions stated in the specifications.*

**ATTENTION:****Fire and burns hazard if battery terminal is bypassed!**

- *Please take great care to ensure that the battery terminals are never short-circuited with tools or mechanical mobility device parts!*
- *Ensure that the battery terminal caps have been replaced if you are not working on the battery terminals.*

**ATTENTION: Danger of crushing!****The batteries are extremely heavy. This results in injury hazards to your hands.**

- *Bear in mind that the batteries are sometimes very heavy!*
- *Please handle the batteries with care.*

**WARNING: BURN HAZARD!****Injury hazard due to discharged acid.**

- *Always wear acid-proof protective gloves when handling batteries.*
- *Always wear protective goggles when handling batteries.*

**What to do if acid is discharged:**

- *Always take clothing which has been soiled by or dipped in acid off immediately!*
- *Rinse any areas of your skin which has come into contact with battery acid off immediately with plenty of water!*

If contact with eyes is made:

- *Rinse the affected eye under running water for several minutes! You should also consult an eye specialist immediately afterwards!*

**Requirements:**

- 11 mm socket spanner

Removing the batteries:

- Make the batteries accessible as described in chapter 7.3.1.

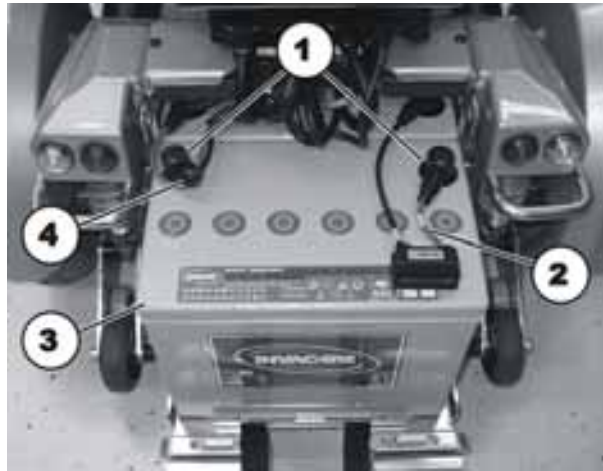

- Remove the pole caps (1) on the accessible battery (3).
- Remove the pole screws located under the pole caps using an 11 mm socket spanner.
- Remove the connecting cable (4) and the fuse cable (2).
- Lift the battery from the battery carrier.
- Pull on the strap of the second battery to move it forward.
- Dismantle the cables on the second battery as well.
- Lift the second battery from the battery carrier.

Refitting the batteries:

- Refit the batteries in reverse order.
- Ensure that the battery cage sockets/plugs have been correctly refitted. A polarity diagram is located in the rear cover.

7.3.3 Correct handling of damaged batteries

**WARNING: BURN HAZARD!****Injury hazard due to discharged acid.**

- *Always wear acid-proof protective gloves when handling batteries.*
- *Always wear protective goggles when handling batteries.*

**What to do if acid is discharged:**

- *Always take clothing which has been soiled by or dipped in acid off immediately!*
- *Rinse any areas of your skin which has come into contact with battery acid off immediately with plenty of water!*

If contact with eyes is made:

- *Rinse the affected eye under running water for several minutes! You should also consult an eye specialist immediately afterwards!*
-

**Requirements:**

- protective goggles
 - acid-proof gloves
 - acid-proof transport container
-

- If handling damaged batteries, always wear suitable protective clothing.
 - Always deposit damaged batteries in suitable acid-proof containers immediately after removal.
 - Only transport damaged batteries in suitable acid-proof containers.
 - Always wash any objects which were contacted by acid in plenty of fresh water.
-

**Always dispose of used or damaged batteries correctly**

Used and damaged batteries will be taken back by your medical equipment supplier or Invacare®.

7.3.4 Checking and replacing the main fuse



CAUTION: Fire hazard!

- Always use an original strip fuse with the approved amperage.
- If the main fuse has blown, first rectify the cause before fitting a new one.



CAUTION: Fire hazard!

Fitting the incorrect strip fuse causes a fire hazard!

- Only fix the strip fuses in the sequence shown in the image on the right!
- Tighten the nuts with 3.3 or 3.5 Nm!

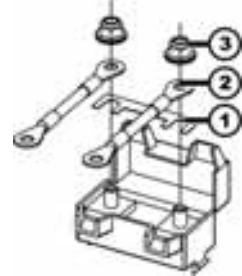

1. Strip fuse

2. Spade terminal

3. DIN 6923 nut



Requirements:

- 8 mm socket spanner



Note

If the fuseholder is damaged, you can replace this complete with the battery cables.

Dismantling the main fuse:

- Remove the battery compartment cover, disconnect the battery plugs and pull the batteries out of the battery compartment as described in chapter 7.3.1.



- The fuseholder (1) is located on top of the batterie.
- Open the fuseholder cover.

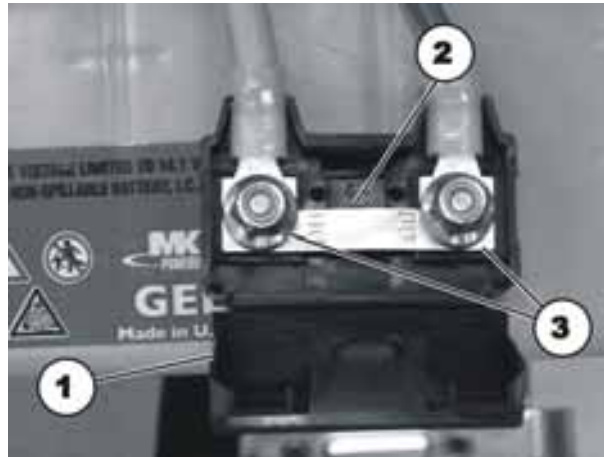

- You see the strip fuses (2) once the fuse holder (1) is open.
- If the strip fuse has blown, you must first ascertain and rectify the cause of the fault.
- The main fuse may only be replaced once the fault has been rectified.
- Remove the strip fuse nuts (3) with an 8 mm socket spanner.
- Replace the strip fuse.

Fitting the main fuse:

- Refit all the parts again in reverse order.
- To conclude, check all the mobility aid functions.

7.3.5 Checking the cable

**Requirements:**

- 4 mm Allen key
- oblique pliers
- cable ties

- Remove the rear and the centre cover as described in chapters 7.1.1 and 7.1.2.
- Pull the batteries out of the battery compartment as described in chapter 7.3.1.



- Check the fuse cable (1) and battery cable (2) for visible damage and crushing points.
- Replace any damaged cables.
- Check all cables for visible damage and crushing locations. Replace any damaged cables.
- Pull each plug (1) carefully. The plug should not come out of the socket.
- If one of the plugs is loose, press it back into the socket with light pressure. The plug must engage.
- Checked to ensure that the plug is now firmly in its socket. If not, repeat the previous operation.
- Refit the parts in reverse order.
- Check all vehicle functions.

7.3.6 Cable routing

**Requirements:**

- 4 mm Allen key
- oblique pliers
- cable ties

- Remove the rear and the centre cover as described in chapters 7.1.1 and 7.1.2 .
- Guide the cables inside of the cover over the cable link (1).
- Secure the cables with the cable clamps (2).

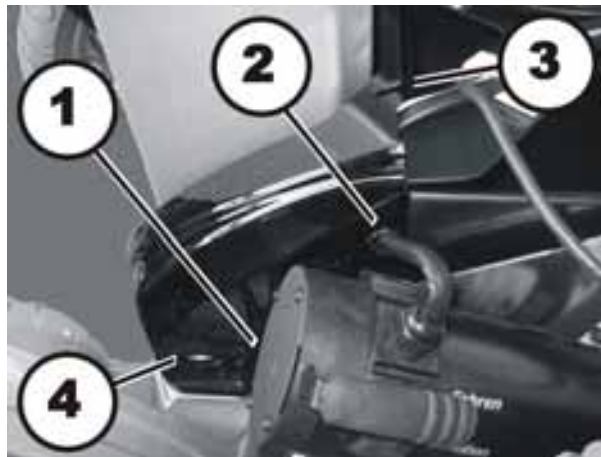

- The motor cables are fitted with protection covers (2) and are guided out of the front cover through recesses on the side.
- Cables that lead to the seat (upper actuator module, remote, headlight), are guided out of the front cover through an upper left recess (3).
- Make sure the cable has enough play so that all movable parts can move freely without stretching, clamping or abrading the cable.
- Lay the cables in the same way under the seat and to the remote. Fasten the cables with the prescribed cable clamps or cable ties respectively.

7.4 Electronics module

7.4.1 Replace remote

**Note**

Replacing the remote is very easy and is not described in detail.

However, when replacing a remote in connection with the power module, please take the final selection of the drive program into account as described in chapter 7.4.6.

7.4.2 Replacing the power module

**Note**

When replacing the power module in connection with a remote, please take the final selection of the drive program into account as described in chapter 7.4.6.

Different power modules in connection with different remotes can be fitted to the mobility aid. The possible power modules are described in chapter 4.2.

Replacement is described in the following section based on the example of a mobility aid with an optional lighting PCB and an optional actuator module.

**CAUTION!**

Any changes to the drive program can affect the driving characteristics and the tipping stability of the mobility aid!

- *Changes to the drive program may only be carried out by trained Invacare® specialist dealers!*
- *Invacare® can only give a warranty for safe mobility aid driving behaviour - especially tipping stability - for unaltered standard drive programs!*

**Note**

All power modules are delivered with a standard drive program. If you have made any customer-specific modifications to the drive program, these must be adapted after the installation of the new power module.

**Requirements:**

- 8 mm socket spanner
- To adapt the drive program:
programming software or hand programming device and system installation manual, available from Invacare®.

Dismantling the power module:

- Remove the rear panel and the centre panel as described in chapters 7.1.1 and 7.1.2.

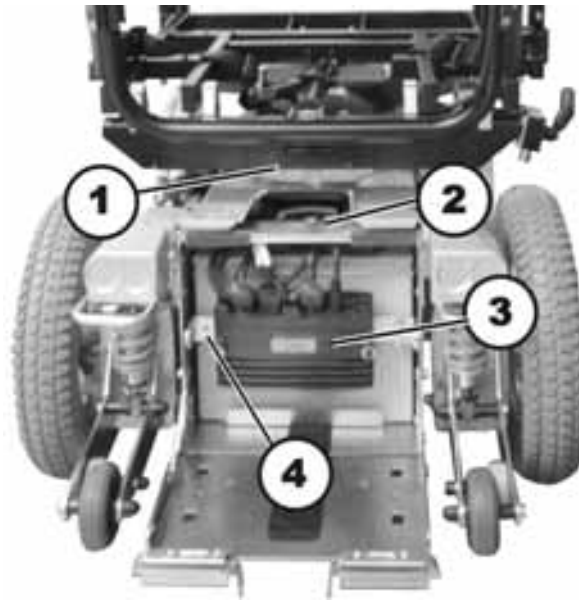

- Carefully note the location of the cable and the connection locations of the various plugs. Either mark each plug and socket, or take a photograph with a digital camera.
- In the illustration above, you see the power module (3) and the positions of the optional lighting circuit board (2), of the optional actuator module (1) and of the optional G-Trac sensor (4).

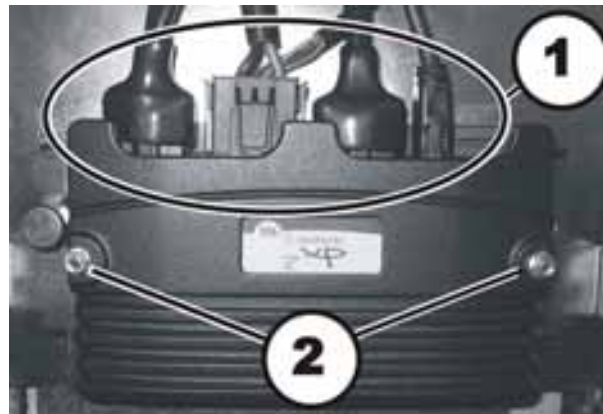

- Pull the plug (1) out of the power module.
- Use a 4 mm Allen wrench to loosen both of the hexagon socket head screws (2).
- Remove the washers and the black intermediate pieces.
- Remove the power module by pulling it backwards from the guides.
- Replace the power module.

Refitting the power module:

- Refit the parts in reverse order.
- Plug all the plugs into their old positions.
- Select the drive program as described in chapter 7.4.6.
- If a new software version is available, update the drive program as described in chapter 7.5.

- Adapt the drive program using the programming software if necessary.
- To conclude, check all the mobility aid functions.

7.4.3 Replacing the actuator module under the seat

The actuator module is optional.



Requirements:

- 4 mm Allen key
-

Removing the actuator module:

- Remove the seat, as described in chapters 7.6.1 and 7.6.5.
- Carefully note the location of the cable and the connection locations of the various plugs. Either mark each plug and socket, or take a photograph with a digital camera.



- Pull the plug (1) out of the actuator module.
- Loosen both hexagon socket head screws (2).
- Replace the actuator module.

Refitting the actuator module:

- Refit the parts in reverse order.
- Plug all the plugs into their old positions.
- To conclude, check all the mobility aid functions.

7.4.4 Replacing the lighting PCB

Replacement is described in the following section based on the example of a mobility aid with an optional lighting PCB.



Requirements:

- 4 mm Allen key
 - 8 mm socket spanner
-

Dismantling the lighting PCB:

- Remove the seat, as described in chapters 7.6.1 and 7.6.5.
- Remove the rear and the centre cover as described in chapters 7.1.1 and 7.1.2.

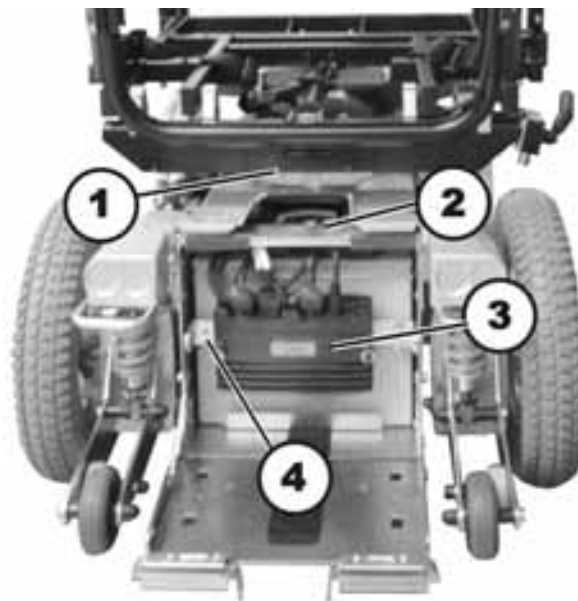

- Carefully note the location of the cable and the connection locations of the various plugs. Either mark each plug and socket, or take a photograph with a digital camera.
- In the illustration above, you see the power module (3) and the positions of the optional lighting circuit board (2), of the optional actuator module (1) and of the optional G-Trac sensor (4).

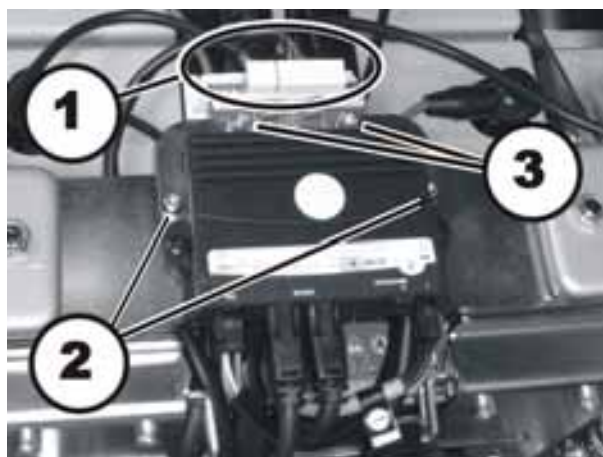

- Pull the plug (1) out of the lighting PCB.
- Undo the two Allen screws (2) with a 4 mm Allen key.
- Lift off the lighting PCB together with the retaining bracket.
- Loosen the two Allen screws (3) and the corresponding nuts on the rear using a 4 mm Allen key and an 8 mm socket spanner.
- Replace the lighting PCB.

Refitting the lighting PCB:

- Refit the parts in reverse order.
- Plug all the plugs into their old positions.
- To conclude, check all the mobility aid functions.

7.4.5 Replacing the G-Trac sensor

**Requirements:**

- 5 mm Allen key
- 10 mm socket wrench

Uninstalling the G-Trac sensor:

- Remove the seat, as described in chapters 7.6.1 and 7.6.5.
- Switch the electronics of the wheelchair OFF.
- Remove the rear cover, as described in chapter 7.1.1.

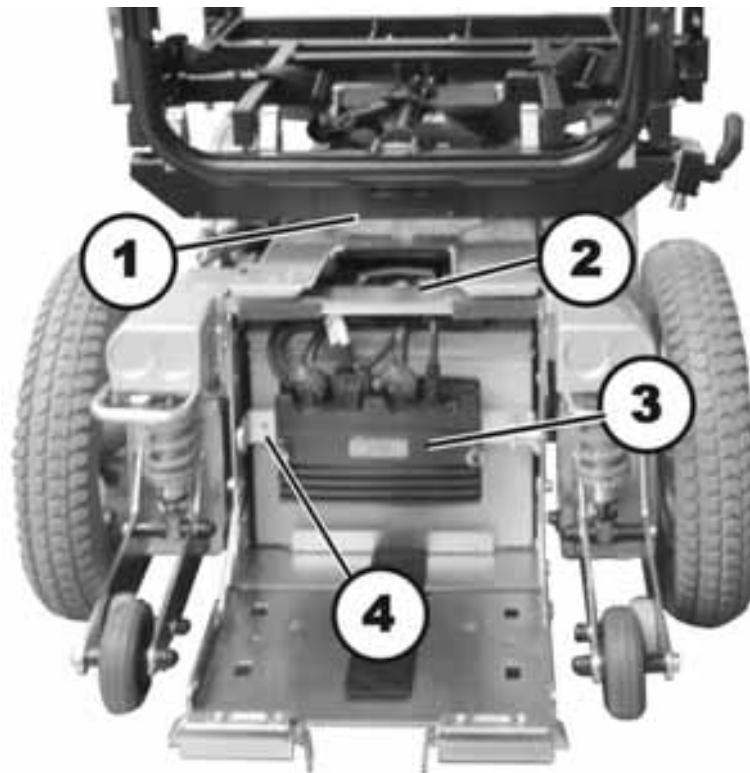

- Take note of the positions of all cables and the sockets that they are connected to. Mark the connectors and sockets or take a photograph with a digital camera.
- In the illustration above, you see the power module (3) and the positions of the optional lighting circuit board (2), of the optional actuator module (1) and of the optional G-Trac sensor (4).
- Remove the rear cover, as described in chapter 7.1.1.
- Press both locking bolts inwards and open the battery box cover.

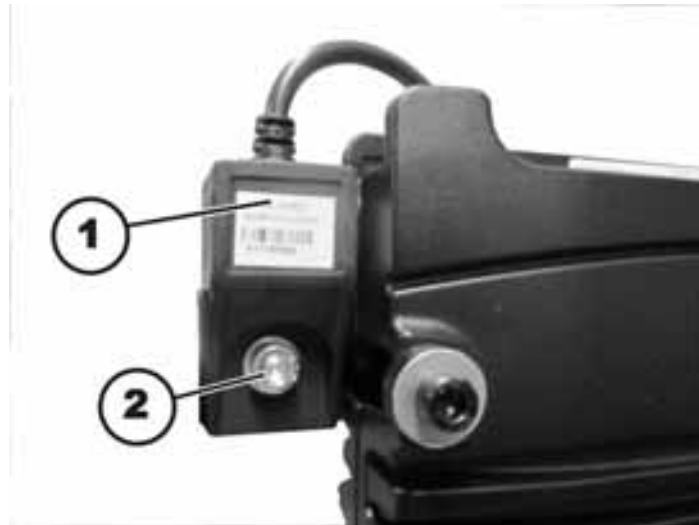

- Disconnecting the cable of the G-Trac sensor from the electronic module.
- Loosen and remove the hexagon socket head screw (2).
- Remove the G-Trac sensor (1).

Installing the G-Trac sensor:

- Assembly of the G-Trac sensor is carried out in the reverse order.
- The G-Trac sensor must be installed with the cable pointing upwards.
- Test all functions of the vehicle.

7.4.6 Drive program selection after component replacement

The drive program is saved in the remote and in the power module. If one of these two components is replaced, the system must be told which of the components has not been replaced so that it knows which contains the current controller profile.



Note

The system allows normal usage of the mobility aid after component replacement only if the profile is selected afterwards.

7.4.6.1 Profile selection with remote REM A or REM B



- Insert the plug into the remote or into the power module respectively.
- Switch the remote on.
- LEDs (1) and (4) blink.
- Use the bottom rocker switch (5) to select where the required controller profile is saved.
LED 1 = power module
LED 4 = remote

Only LED (1) or (4) blinks now depending on the selection.

- Press the "Horn" (2) and "+" (3) buttons on the speed selection and hold them down for 3 seconds to confirm the selection.

The system will switch itself off and restart automatically. In the process, the selected profile is saved in the remote and in the power module.

7.4.6.2 Profile selection with remote REM 550



- Insert the plug into the remote or into the power module respectively.
- Switch the remote on.

The display (2) shows that you need to select a profile.

- Use the bottom rocker switch (3) to select where the required controller profile is saved.
 - I = remote
 - II = power module

The display shows which profile you have selected.

- Press the "Horn" (4) and "+" (1) buttons on the speed selection and hold them down for 3 seconds to confirm the selection.

The system will switch itself off and restart automatically. In the process, the selected profile is saved in the remote and in the power module.

7.5 Updating the driving program

The driving programs for electric wheelchairs are continually updated and improved by Invacare®. For this reason, you should check whether the version number is still up to date each time a wheelchair comes in for repairs, and also during regular inspections.

If a newer version is available, the driving program must be updated. The procedure for updating the driving program is described in the user manual of the Wizard software.



Note

The electronic system is supplied with a standard drive program. If the driving program has been customised, you have to perform this customisation again, after installing the new driving program.



WARNING: Every alteration to the drive program can influence vehicle handling and the tipping stability of the wheelchair!

- *Alterations to the drive program must only be carried out by trained Invacare®-dealers!*
 - *Invacare® can only assume a warranty for the safe vehicle handling of the wheelchair – in particular tipping stability - for unaltered standard drive programs!*
-



Pre-requisites:

- Dynamic® Wizard software
 - User manual for the Wizard software
 - For further information on other requirements - such as the minimum system configuration of the PC to be used for programming, necessary programming cables - see the user manual of the Wizard software. You find the latest version of the user manual in the download area on <http://www.dynamiccontrols.com/>.
-

7.6 Seat support and tilt module

7.6.1 Replacing the seat support with manual tilt module (till Dec. 2010)



WARNING: Danger of crushing!

The seat/seat support is very heavy. Injury hazard to hands and feet!

- You should seek help from a second person.



Requirements:

- T40 torx wrench
- oblique pliers
- cable ties

Dismantling the seat support:

- Remove the legrests.
- Remove the armrests.
- Remove the seat cushion.
- Remove any existing cable ties holding the cables on the remote or lighting. Remove the cables from the stuck on clamps.
- Loosen the cap nuts of the headlight mountings using an 8 mm jaw spanner (see chapter 7.2.3).
- Put the headlight and the mounting in a safe place on the rear part of the battery compartment cover.
- Remove the connecting cable to the chassis from the remote or from the optional actuator module.
- Remove the cable or cables so that there is no longer any cable connection between the seat and the chassis.

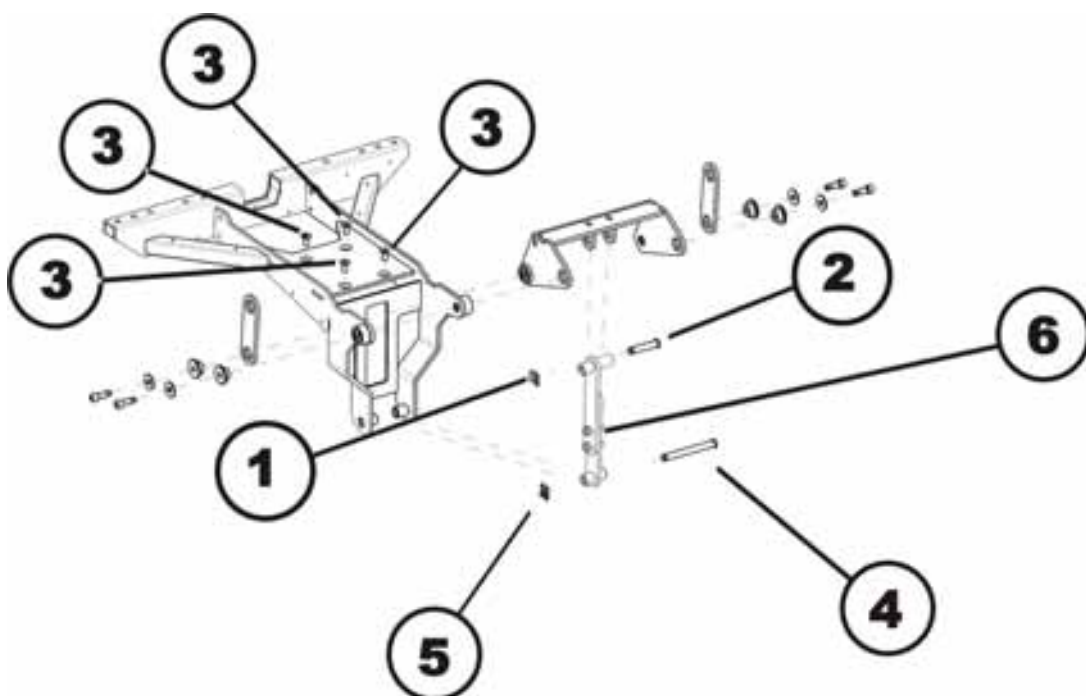

- Remove the pin retainer (1).
- Remove the pin (2).
- Swing the brace (6) forwards.
- Remove the bolt retainer clip (5).
- Remove the bolt (4).
- Remove the brace.
- Fold back the entire seat.
- Keep a firm hold on the seat and the seat support whilst loosening and removing the four torx screws (3).
- Lift the seat and the seat support from the vertical column.

Refitting the seat carrier:

- Refit the parts in reverse order.
- To conclude, check all the mobility aid functions.

7.6.2 Adjusting the seat tilt on a seat with a manual tilt module (till Dec. 2010)



WARNING: Danger of crushing!

The seat/seat support is very heavy. Injury hazard to hands and feet!

- You should seek help from a second person.



Requirements:

- 6 mm Allen key

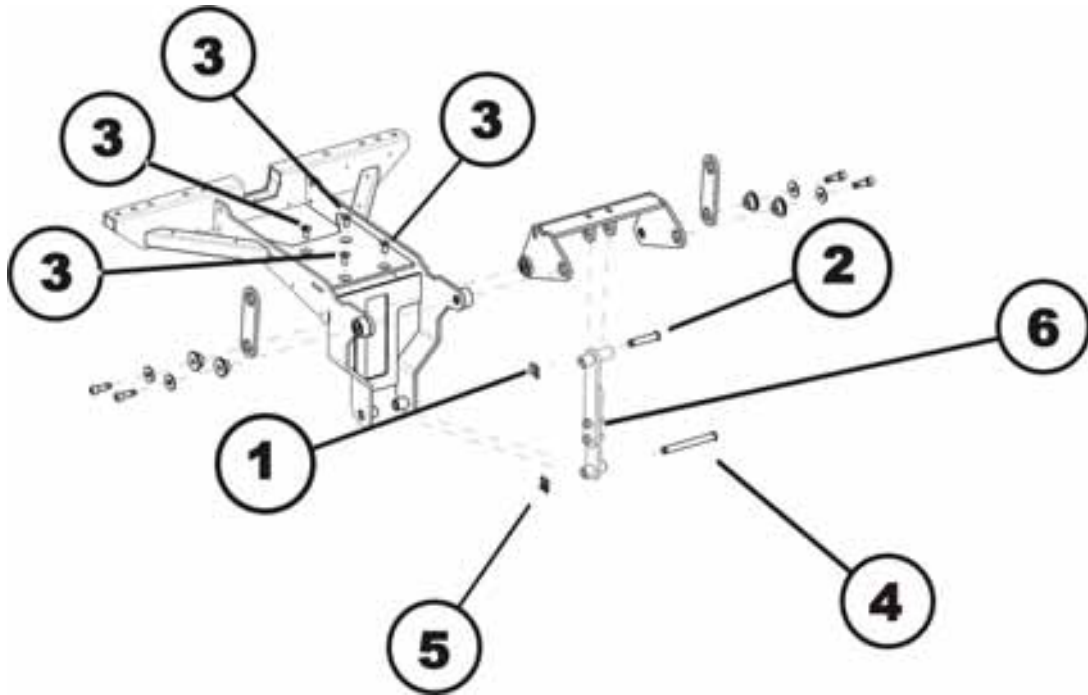

- Let a 2nd person hold on to the seat. Please take into account that the seat is very heavy. Be sure not to crush your fingers or other parts of the body.
- Loosen and remove the two Allen screws (6) with a 6 mm Allen key.
- Tilt the seat to the desired gradient.
- Place the two parts of the strut on top of each other.
- Refit the Allen screws and tighten them.
- To conclude, check all the mobility aid functions.

7.6.3 Replacing the seat frame with a manual tilt module (from Dec. 2010)



CAUTION: Danger of crushing!

- *The seat/seat support are very heavy. You should seek help from a second person who can secure the seat and help when carrying.*



Requirements:

- T40 torx wrench
- oblique pliers
- cable ties

Dismantling the seat support:

- Remove the legrests.
- Remove the armrests.
- Remove the seat cushion.
- Remove any existing cable ties holding the cables on the remote or lighting. Remove the cables from the stuck on clamps.
- Loosen the cap nuts of the headlight mountings using an 8 mm jaw spanner (see chapter 7.2.3).
- Put the headlight and the mounting in a safe place on the rear part of the battery compartment cover.
- Remove the connecting cable to the chassis from the remote or form the optional actuator module.
- Remove the cable or cables so that there is no longer any cable connection between the seat and the chassis.

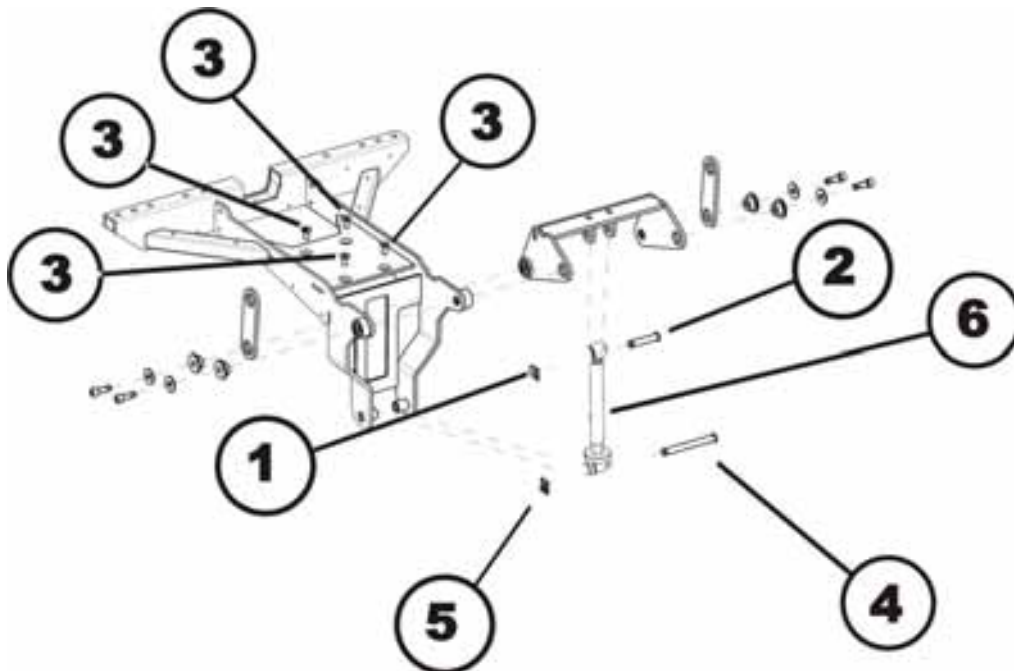

- Remove the pin retainer (1).
- Remove the bolt (2).

- Swing the brace (6) forwards.
- Remove the bolt retainer clip (5).
- Remove the bolt (4).
- Fold back the entire seat.
- Keep a firm hold on the seat and the seat support whilst loosening and removing the four torx screws (3).
- Lift the seat and the seat support from the vertical column.

Refitting the seat carrier:

- Refit the parts in reverse order.
- To conclude, check all the mobility aid functions.

7.6.4 Adjusting the seat tilt on a seat with a manual tilt module (from Dec. 2010)



WARNING: Danger of crushing!

The seat and frame are very heavy and can fall down without warning if the seat tilt adjustment assembly is screwed apart too far. Danger of injury to hands and feet!

- *Make sure that you only adjust the seat tilt to a maximum of 25°.*



Requirements:

- 19mm open-end wrench
- Protractor

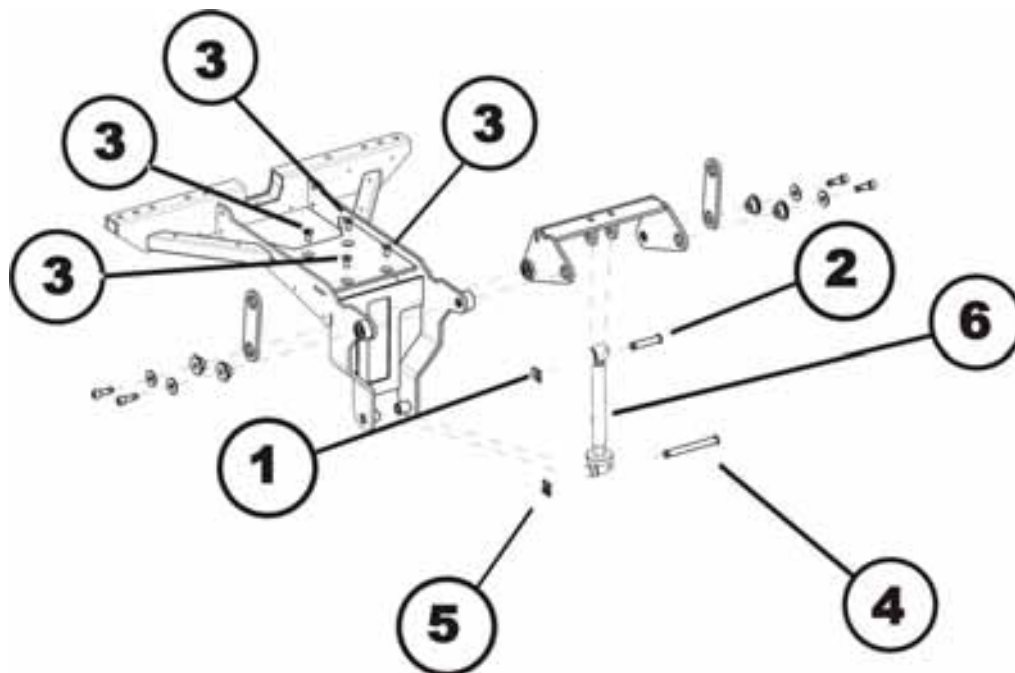

- Apply the open-end wrench to the hexagon bolt (6) of the tilt adjustment.
- Turn the tilt adjustment, until the desired angle or a maximum of 25° is reached.

7.6.5 Replacing the seat support with electric tilt module



CAUTION: Danger of crushing!

- The seat/seat support are very heavy. You should seek help from a second person who can secure the seat and help when carrying.



Requirements:

- T40 torx wrench
- oblique pliers
- cable ties

Dismantling the seat support:

- Remove the legrests.
- Remove the armrests.
- Remove the seat cushion.
- Remove any existing cable ties holding the cables on the remote or lighting. Remove the cables from the stuck on clamps.
- Loosen the cap nuts of the headlight mountings using an 8 mm jaw spanner (see chapter 7.2.3).
- Put the headlight and the mounting in a safe place on the rear part of the battery compartment cover.
- Remove the connecting cable to the chassis from the remote or form the optional actuator module.
- Remove the cable or cables so that there is no longer any cable connection between the seat and the chassis.

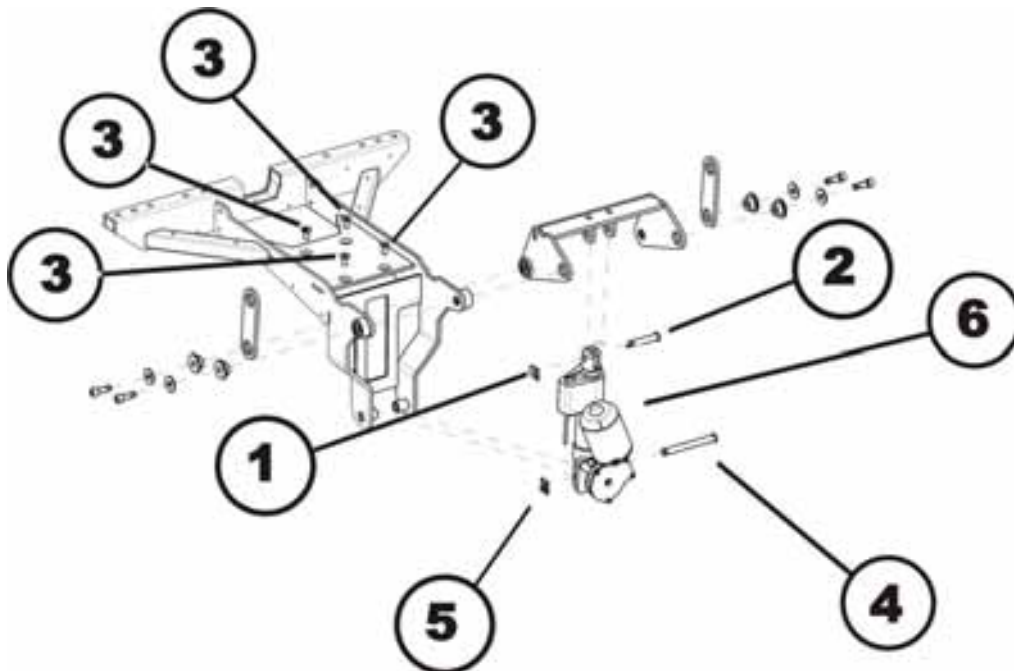

- Remove the pin retainer (1).
- Remove the bolt (2).

- Swing the tilt actuator (6) forwards.
- Remove the bolt retainer clip (5).
- Remove the bolt (4).
- Remove the tilt actuator (6).
- Fold back the entire seat.
- Keep a firm hold on the seat and the seat support whilst loosening and removing the four torx screws (3).
- Lift the seat and the seat support from the vertical column.

Refitting the seat carrier:

- Refit the parts in reverse order.
- To conclude, check all the mobility aid functions.

7.6.6 Replacing the tilt actuator



Requirements:

- Oblique pliers
- Cable ties

Dismantling the tilt actuator:

- Remove the I
- egests.
- Pull the tilt actuator plug out of the actuator module under the seat
- Unclip the cable. Remove any cable ties which are fitted.

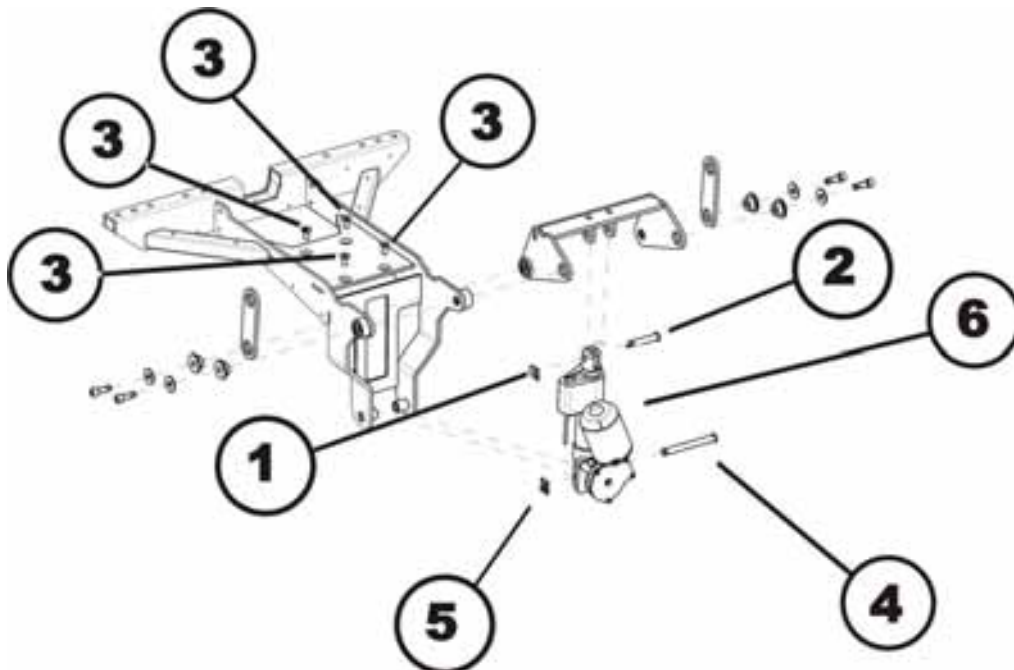

- Remove the upper pin retainer (1).
- Remove the upper bolt (2).
- Swing the tilt actuator (6) forwards.
- Remove the lower pin retainer (5).
- Remove the lower pin (4) and remove the entire tilt actuator.
- Replace the tilt actuator.

Refitting the tilt module:

- Refit the parts later in reverse order.
- To conclude, check all the mobility aid functions.

7.7 Lifting column

**WARNING: Danger of crushing!**

The seat is very heavy. Injury hazard to hands and feet!

- You should seek help from a second person.
-

**WARNING: Danger of crushing!**

The mobility device is very heavy. Injury hazard to hands and feet!

- You should seek help from a second person.

Injury hazard caused by uncontrolled movement of the mobility device!

- Switch the power supply off (ON/OFF key).
 - Engage the drive.
 - Save the vehicle laid on its side against overturning.
-

**Requirements:**

- 4 mm Allen key
 - T40 torx wrench
 - Oblique pliers
 - Cable ties
-

Dismantling the lifting column:

- Remove the rear battery compartment cover as described in chapter 7.1.1.
- Remove the centre battery compartment cover as described in chapter 7.1.2.
- Remove the front battery compartment cover as described in chapter 7.1.3.
- Remove the seat as described in chapter 7.6.1 or 7.6.5 respectively.
- Obtain the aid of a second person to place the mobility aid on its side and safeguard it against overturning.

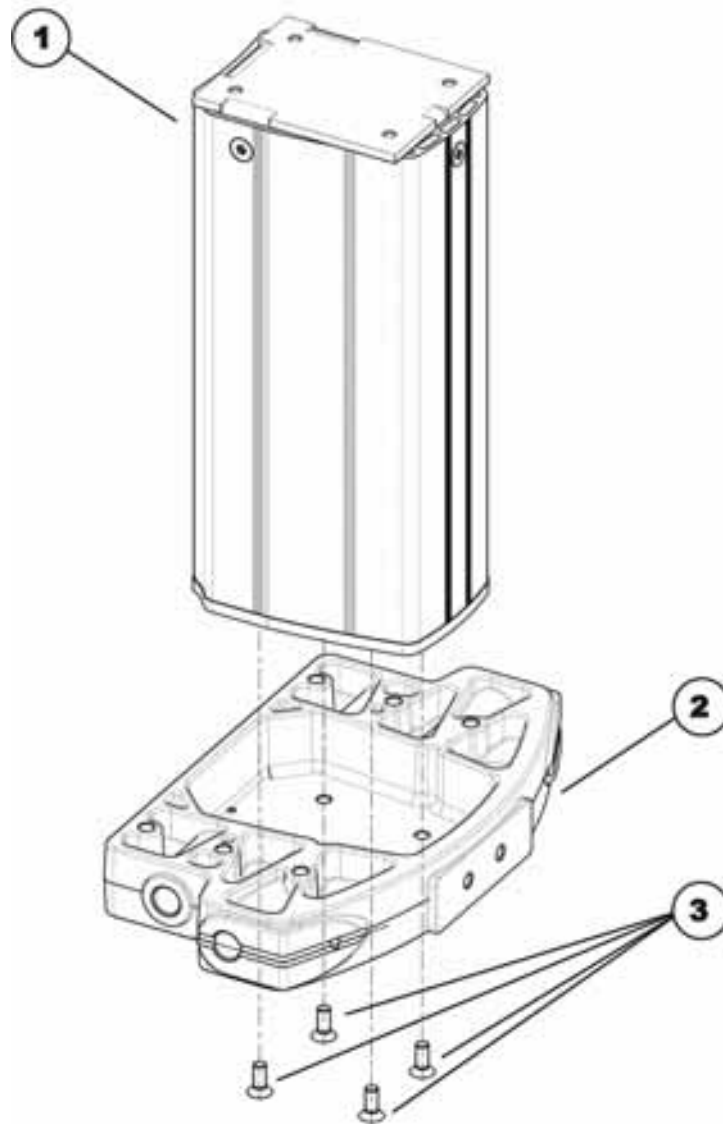

- Loosen and remove the four torx screws (3) on the underside of the chassis (2).
- Remove the lifting column (1).

Refitting the lifting column:

- Refit the parts in reverse order.
- To conclude, check all the mobility aid functions.

7.8 Seat height adjustment

7.8.1 Adjusting the seat height with a manual lifter pillar



WARNING: Danger of crushing!

The seat is very heavy. Injury hazard to hands and feet!

- *You should seek help from a second person.*
-



WARNING: Danger of crushing!

Injury hazard caused by uncontrolled movement of the mobility device!

- *Switch the power supply off (ON/OFF key).*
 - *Engage the drive.*
-



Requirements:

- 4 mm Allen key
 - T40 torx wrench
 - Oblique pliers
 - Cable ties
-

Manual seat height adjustment

- Remove the seat as described in chapter 7.6.1 or 7.6.5.

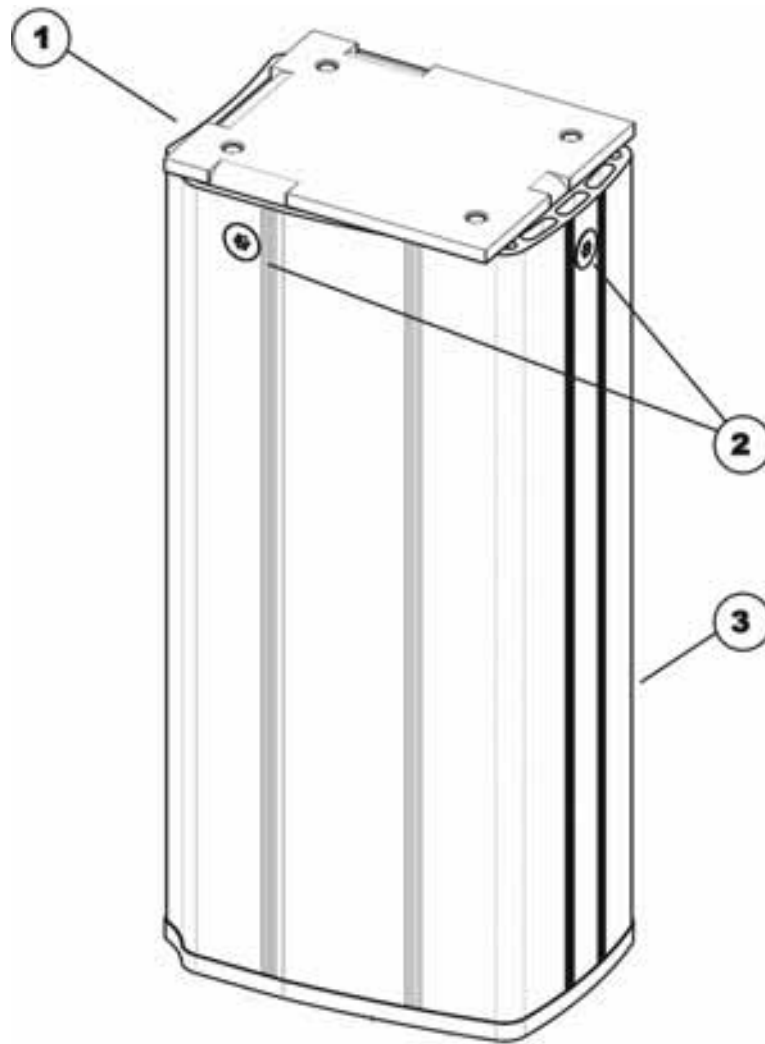

- Loosen and remove the four torx screws (2) on the underside of the column (3).
- Lift off the coverplate (1).

**Note**

The cover plate has four flaps pointing downward. There are two tapped holes on each flap for the screws (2). By selecting the upper or lower holes, the seat can be adjusted to two different heights.

- Attach the cover plate (1).
- Install the screws (2) in such a way that the cover plate is flush fitted or is somewhat elevated depending on the desired seat height.
- Refit the other parts in reverse order.
- To conclude, check all the mobility aid functions.

7.9 Replacing the safety belt

**Requirements:**

- 10 mm socket spanner
- 4 mm Allen key

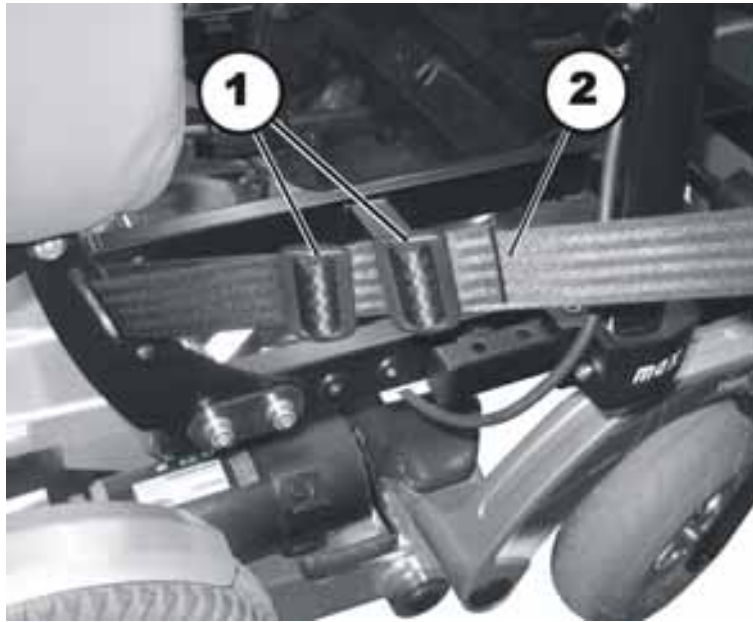
**Dismantling the safety belt:**

- Pull the end of the belt out of both belt guides (1).
- Pull the restraining belt (2) out of the loop on the wheelchair.
- Pull the complete restraining belt (2) out of both of the belt guides (1).
- Remove the nut including the washer.
- Replace the restraining belt (1).

Refitting the safety belt:

- Refit the parts in reverse order.
- Adjust the restraining belt individually to the driver by modifying the clearance of both of the belt guides.

7.10 Seat support

7.10.1 Adjusting the seat width

**Note**

The seat width can be adjusted by installing one of three different seat frames.

**Requirements:**

- Phillips screwdriver, size 2
- 6 mm Allen wrench
- 8 mm Allen wrench

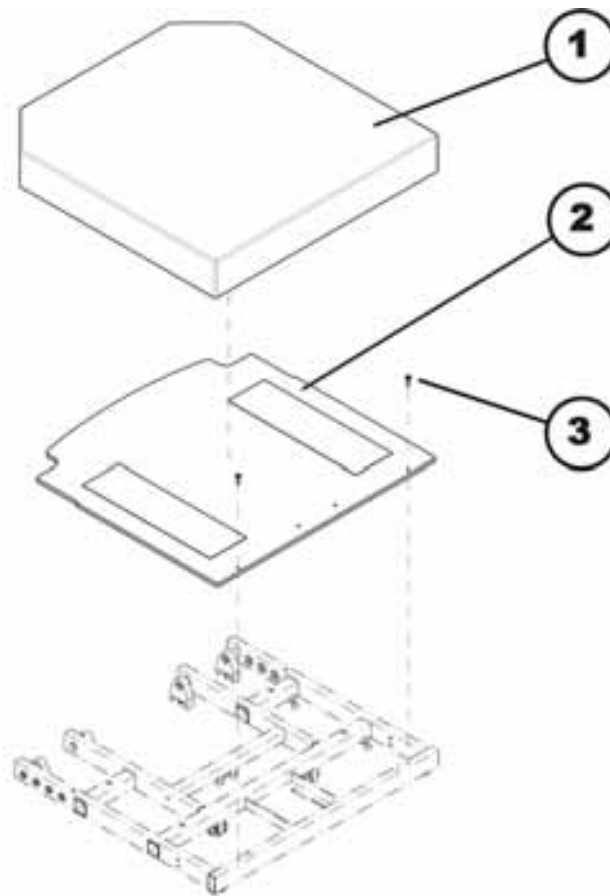
**Uninstalling the seat frame:**

- Remove the seat cushion (1).
- Loosen both Phillips screws (3) and remove them.
- Remove the cover plate (2).
- Remove the actuator for the seat tilt, as described in chapter 7.6.6.
- Remove the back part, as described in chapter 7.6.6.

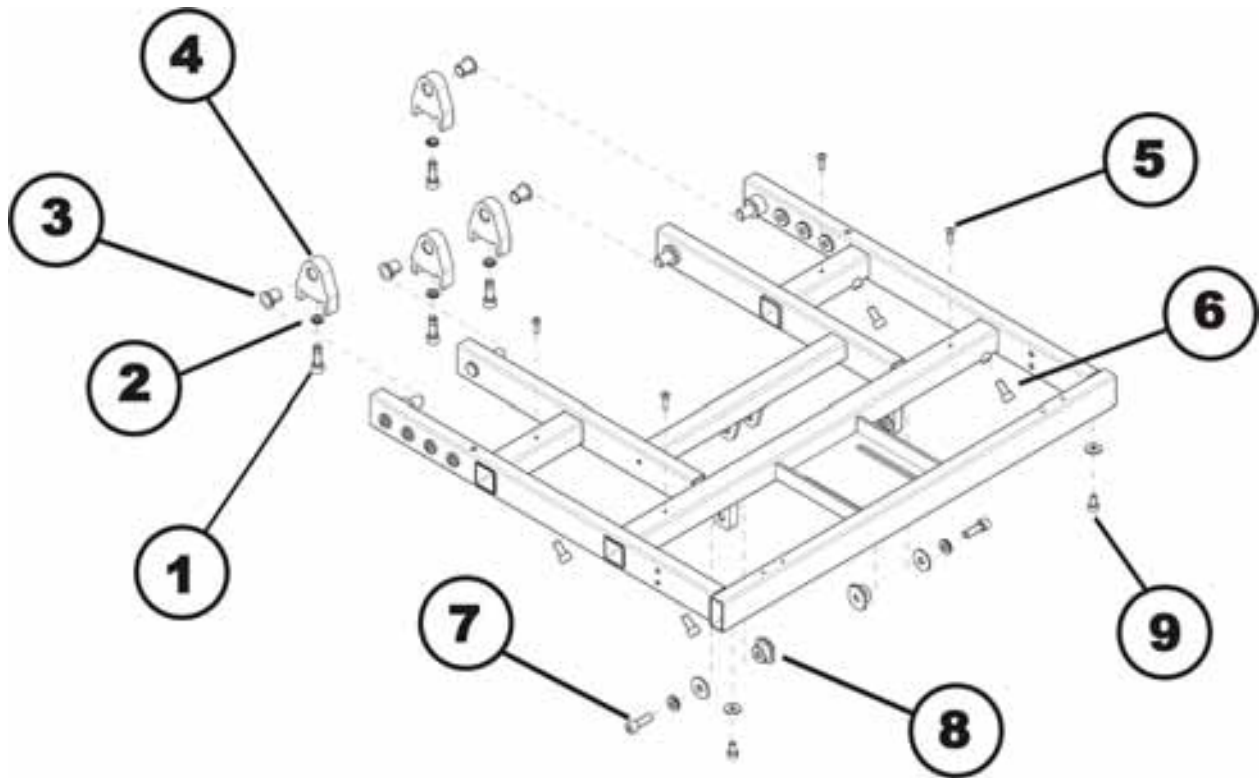

- Loosen and remove the hexagon socket head screws (1) and the washers (2) on the four frame supports (4).
- Remove the four frame supports (4) and the corresponding flanged bushings (3).
- Loosen both Phillips screws (5) which secure the armrests.
- Loosen the four fastening screws of the armrests (6).
- Remove the armrests.
- Loosen and remove both of the fastening screws (7) and (8) of the front frame fixation.
- Loosen and remove both of the screws under the front of the frame (9).
- Remove the seat frame.
- Tighten all screws again.

Installing the seat frame:

- Assemble the parts in reverse order.
- Adjust the restraining belt individually to the driver by modifying the clearance of both of the belt guides.

7.10.2 Adjusting the seat depth



Note

The seat depth can be adjusted to three different positions.



Requirements:

- 4 mm Allen key
- 8 mm jaw spanner
- Oblique pliers
- Cable ties



Note

Certain holes in the seat support must be used for the screws depending on the desired seat depth. It may possibly be necessary to replace the seat support plates.

- Use the following illustration and table to determine which holes must be utilized for the desired seat depth. Additionally, a sticker is attached to the frame that indicates the appropriate holes for the three seat depths.

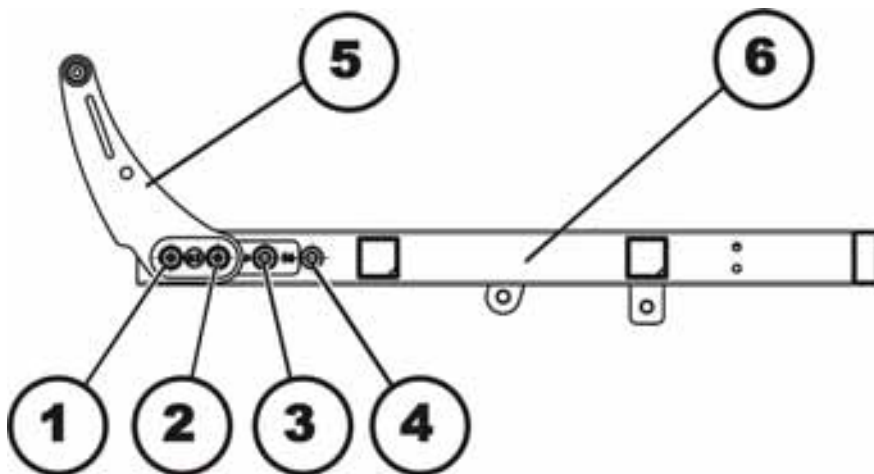

Sitztiefe in cm	Verwendete Löcher in Sitzrahmen
56	3 & 4
59,5	2 & 3
63	1 & 2

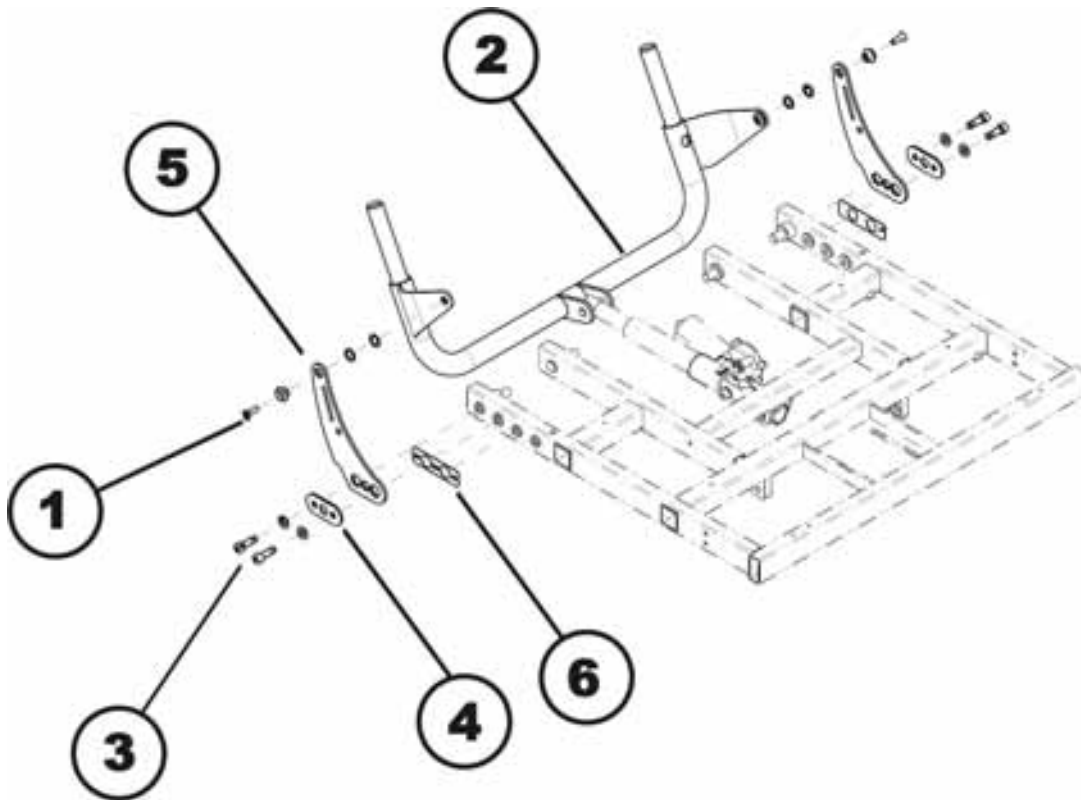
**Uninstalling the backrest:**

- Loosen and remove the hexagon socket head screws (1), which hold the backrest unit.
- Swing the backrest unit (2) towards the rear.
- Loosen and remove the hexagon socket head screws (3) including the washers, the cover plate (4) and the bearing plate (5).
- The sticker (6) indicates the holes for the adjustment of the seat depth.

Installing the backrest:

- Assemble the parts in reverse order.
- Utilize the holes for the desired seat depth.

7.11 Back unit

7.11.1 Adjusting the belt back

The belt back can be individually adapted to the back shape of the user.

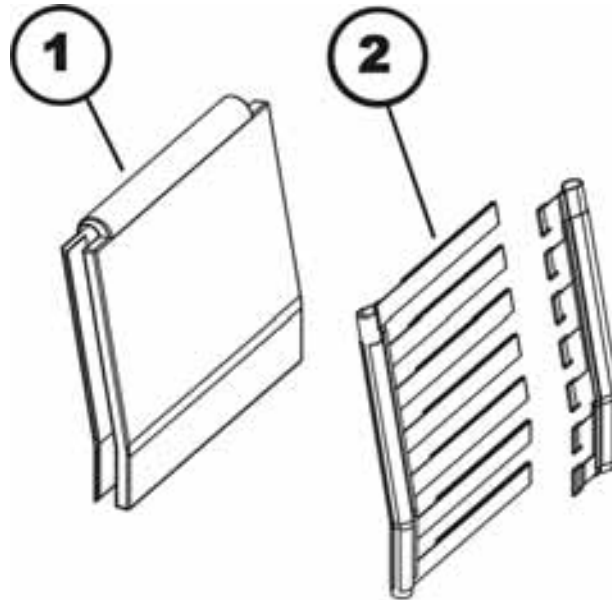

- Pull apart the front and back of the back cushion (1) and remove it. Front and back of the back cushion is held together by Velcro.
- Open Velcro straps of the back straps (2) and set it to the desired length.
- Refit the back cushion and fasten with Velcro.

7.11.2 Adjusting a sling backrest

**Requirements:**

- 5 mm Allen key



- Loosen the hexagon socket head screws (1).
- Shift the position of the cross braces (2) together with the sliding nuts in the channels.
- Re-tighten the hexagon socket head screws again.

7.11.3 Replacing the cross braces

**Requirements:**

- 5 mm Allen wrench



- Loosen and remove the hexagon socket head screws (1) of the cross brace to be replaced (2).
- Remove the cross brace (2) and replace it.
- Install the new cross brace in reverse order.

7.11.4 Replacing a standard backrest

**Requirements:**

- 5 mm Allen wrench

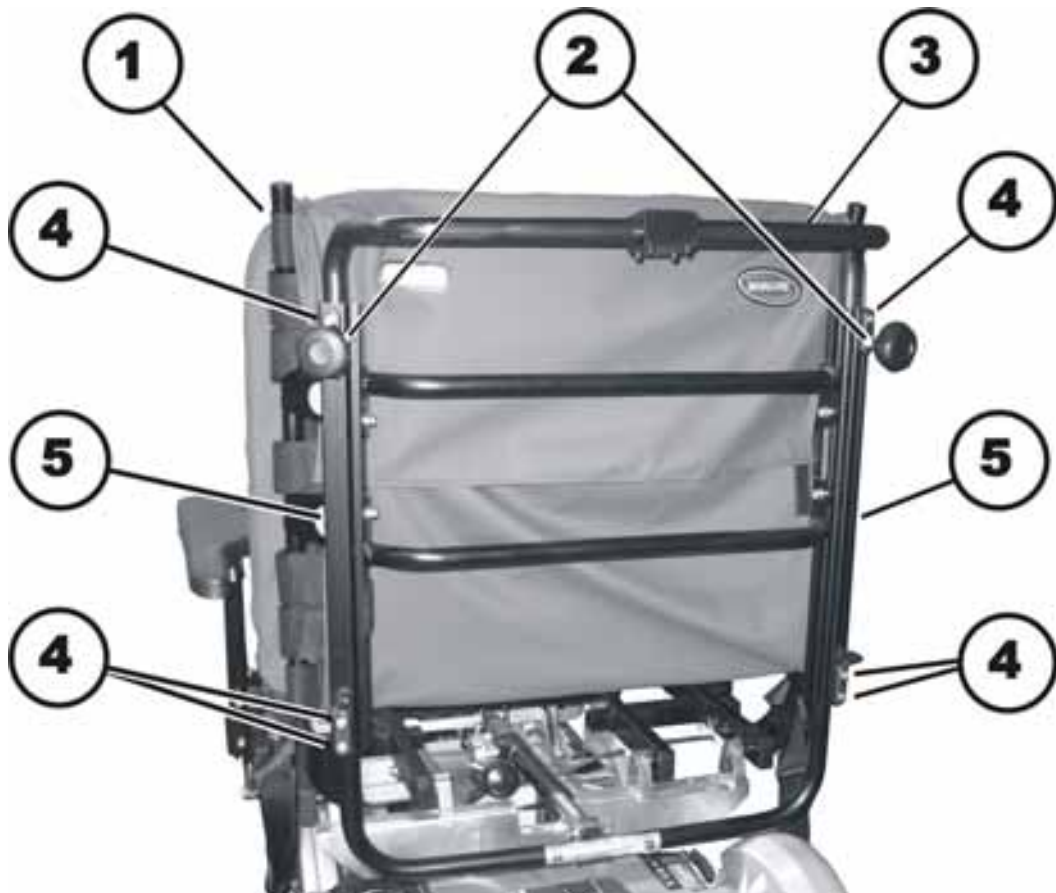
**Uninstalling the backrest unit:**

- Remove the backrest cushion (1).
- Loosen the hand wheels (2) and the hexagon socket head screws (4) on the left and right side of the chair.
- Remove the backrest tube (3) from the channels (5).
- Remove the channels.

Installing the backrest unit:

- Assemble the parts in reverse order.
- The last step is to test all functions of the vehicle.

7.12 Fitting the headrest

7.12.1 Fitting the headrest to the standard back

**Requirements:**

- 5 mm Allen key
- 10 mm socket spanner

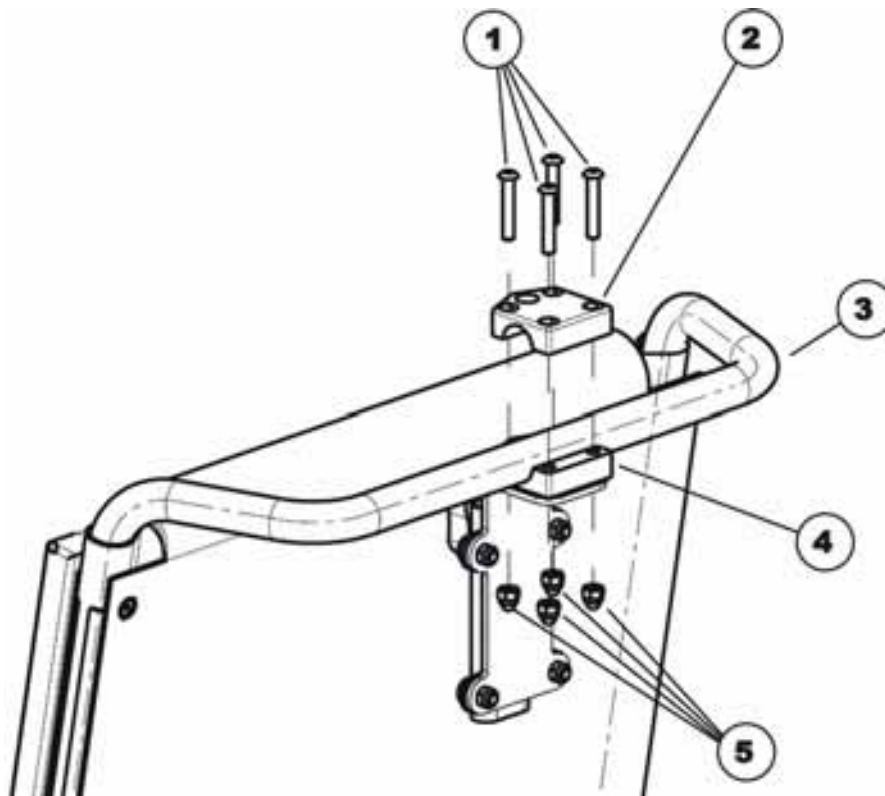

- Gripping it at the base, hold the lower section of the headrest mounting (4) with the clamp block against the handlebar (3).
- Attach the clamp cover (2).
- Insert the four Allen screws (1) from above through the boreholes.
- Fit the four cap nuts (5) to the screws from underneath.
- Use a 5 mm Allen key and a 10 mm socket spanner to tighten the screws and the cap nuts.
- Fit the headrest in the guide bar.

7.13 Installing armrests



Requirements:

- 4 mm Allen wrench
- T30 Torx wrench
- 10 mm socket wrench
- Rubber hammer

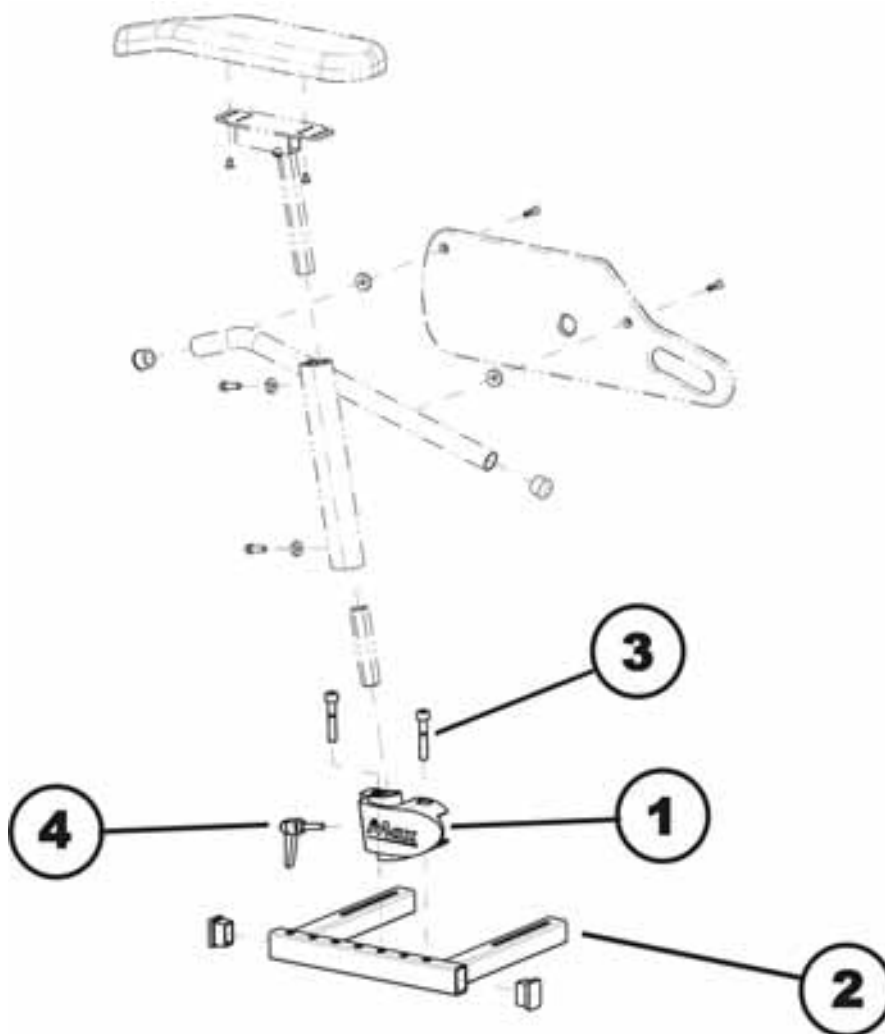

- Install the armpad as shown in the illustration above.
- Install the armrest as shown in the illustration above.
- Attach the armrest along with the holder (1) to the mounting bracket (2). Utilize the screws (3) for this purpose. By selecting different holes in the mounting bracket (1), the depth of armrest can be adjusted.
- Insert the armpad into the armrest and secure it using the screw (4).

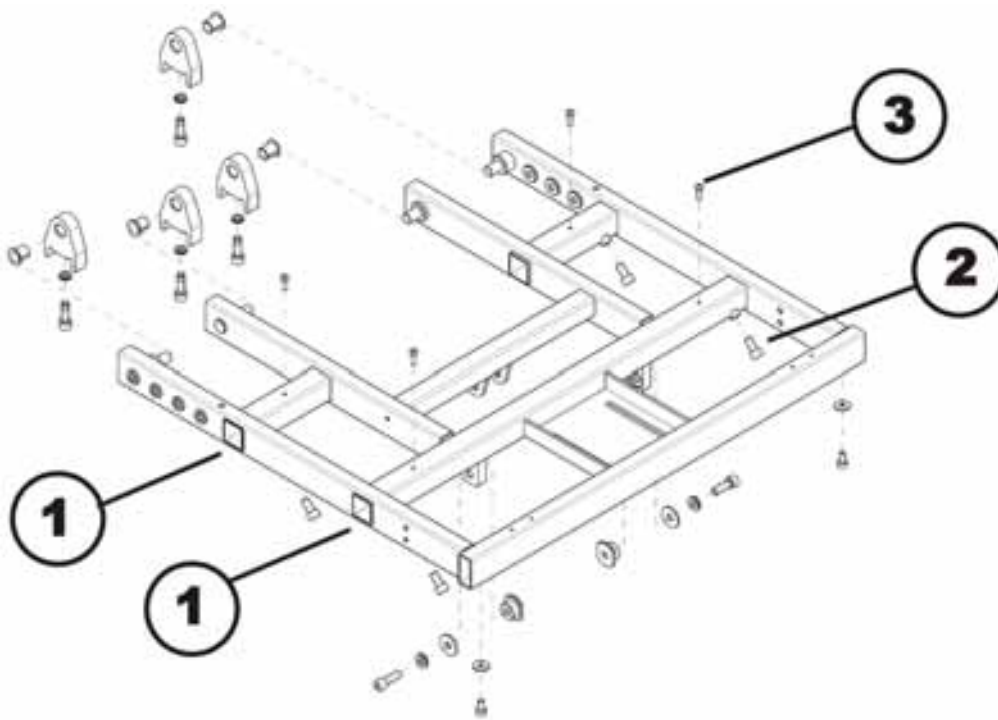

- Insert the four fixation screws of the armrests (2) and tighten them. The insertion depth depends on the desired seat width.
- Insert the four Phillips screws (3) that secure the armrests and tighten them.

7.14 Installing a footrest

**Requirements:**

- 5 mm Allen wrench
- T30 Torx wrench
- 10 mm socket wrench



- Insert the braces (3) of the footrest (2) into the fixation tubes. Pay attention to the correct height while doing so.
- Insert the four hexagon socket head screws (1) into the fixation tubes and tighten them.

7.15 Installing calf supports

**Requirements:**

- 5 mm Allen wrench
- T30 Torx wrench
- 10 mm socket wrench

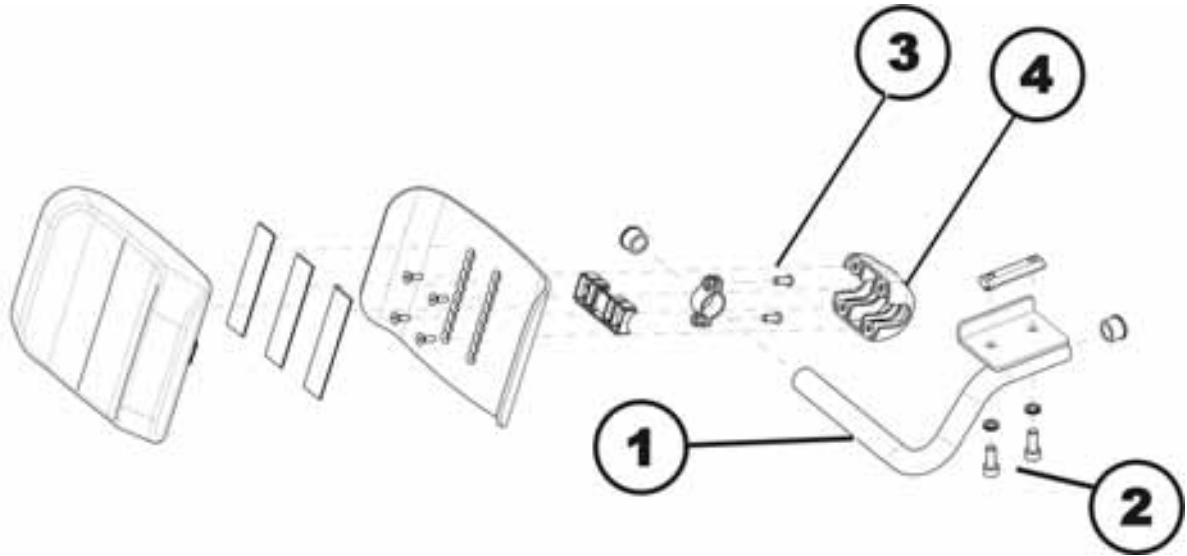

- Install the calf supports as shown in the illustration above.
- Attach the fixation bracket (1) of the calf support to the wheelchair using the hexagon socket head screws (2).
- The angle of the calf supports can be adjusted by loosening the screws (3). The cover (4) has openings, so that the screws are accessible.

7.16 Replacing the front wheel carrier

7.16.1 Replacing the front wheel carrier



WARNING: Danger of crushing!

The mobility device is very heavy. Injury hazard to hands and feet!

- You should seek help from a second person.

Injury hazard caused by uncontrolled movement of the mobility device!

- Switch the power supply off (ON/OFF key).
- Engage the drive.
- Before raising the vehicle, secure the wheels by blocking them with wedges.



Requirements:

- 5 mm Allen key
- 17 mm Allen key
- blade screwdriver
- 25 Nm torque wrench
- 200 Nm torque wrench
- long wooden blocks, min. 14 x 14 x 30 cm

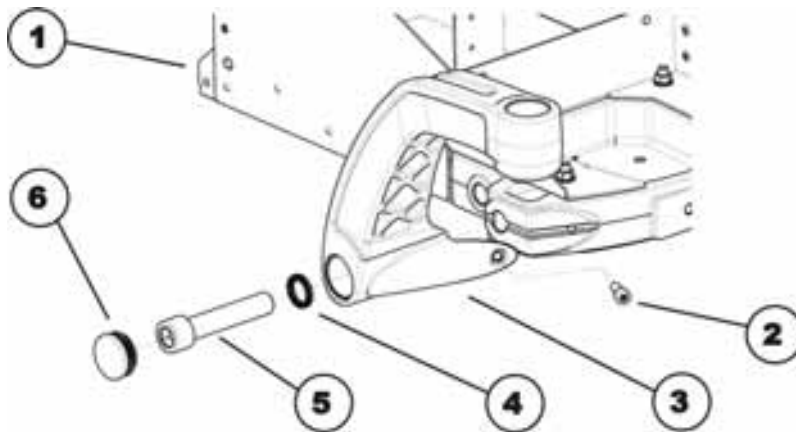

Dismantling the front wheel carrier:

- With the aid of a second person, jack up the mobility aid using several wooden blocks.
- Use a screwdriver to remove the plastic cap (6).
- Loosen and remove the Allen screw (2) with a 5 mm Allen key.
- Loosen and remove the Allen screw (5) with a 17 mm Allen key.
- Remove the two Nord-Lock lock washers (4).
- Remove and replace the front wheel carrier (3).

Refitting the front wheel carrier:

- Refit the parts in reverse order.
- Use Loctite locking varnish to secure the Allen screw (2).
- Tighten the Allen screw (2) to 25 Nm.
- Tighten the Allen screw (5) to 200 -180 Nm.
- To conclude, check all the mobility aid functions.

7.17 Front wheel forks

7.17.1 Replacing the wheel fork



WARNING: Danger of crushing!

The mobility device is very heavy. Injury hazard to hands and feet!

- You should seek help from a second person.

Injury hazard caused by uncontrolled movement of the mobility device!

- Switch the power supply off (ON/OFF key).
- Engage the drive.
- Before raising the vehicle, secure the wheels by blocking them with wedges.



Requirements:

- 19 mm socket spanner
- blade screwdriver
- long wooden blocks, min. 14 x 14 x 30 cm

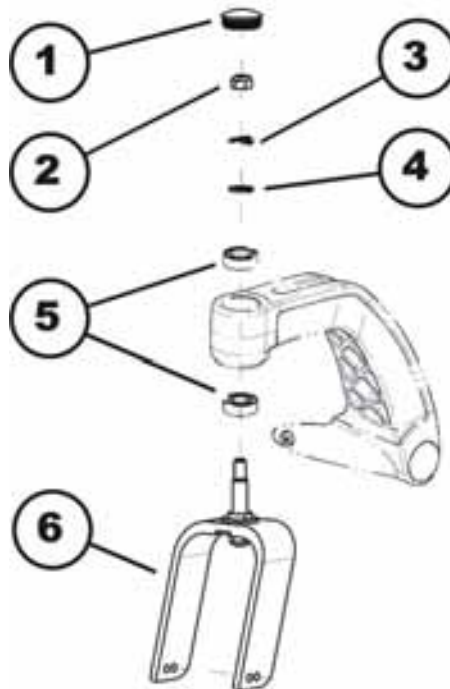

Dismantling the wheel fork:

- Prop up the wheelchair on multiple wooden blocks with the help of a second person.
- Remove the plastic cap (1) with a screwdriver.
- Use the 19 mm socket wrench to loosen and remove the nuts (2).
- Pull the wheel fork (6) downwards out of the front wheel suspension (1). Pay attention to the washers (3), spacer rings (4) and Magneto bearings (5) when doing this.

Refitting the wheel fork:

- Refit the parts in reverse order.
- When fitting the ball bearings please ensure that the wide inner ring faces outward in each case.
- Adjust the wheel fork as described in chapter 7.17.2.
- To conclude, check all the mobility aid functions.

7.17.2 Adjusting the wheel fork



WARNING: Danger of crushing!

The mobility device is very heavy. Injury hazard to hands and feet!

- *You should seek help from a second person.*



Requirements:

- 19 mm socket spanner
- blade screwdriver

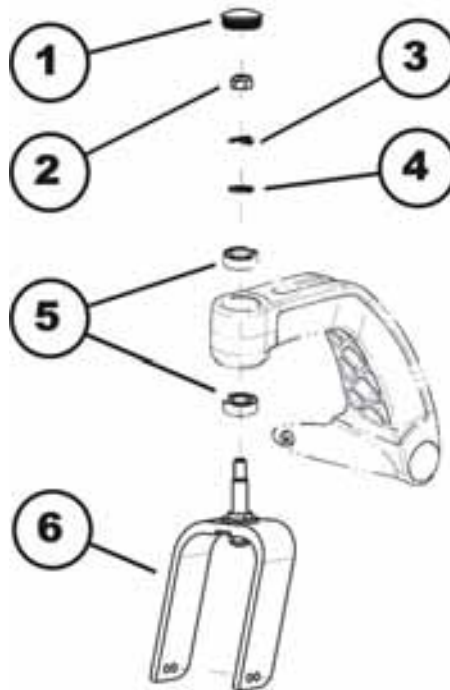

- If necessary remove the cover cap (1).
- Get help of a second person to tilt the mobility aid to the rear.
- Rotate the wheel forks (6) upwards.
- Let go of the wheel forks so that they can swing downwards again.
- Adjust the nut (2) with a 19mm socket spanner so that the wheel forks are not too loose but can still rotate freely.
The wheel forks should oscillate to the opposite side a maximum of once and then come to rest facing downwards.
- Place the mobility aid on all four wheels again.
- Test the mobility aid's manoeuvrability.
- Repeat the adjustment steps if necessary until the castors are correctly adjusted.
- Refit the cap (1).

7.17.3 Changing a front wheel



WARNING: Danger of crushing!

The mobility device is very heavy. Injury hazard to hands and feet!

- You should seek help from a second person.

Injury hazard caused by uncontrolled movement of the mobility device!

- Switch the power supply off (ON/OFF key).
- Engage the drive.
- Before raising the vehicle, secure the wheels by blocking them with wedges.



Requirements:

- 5 mm Allen wrench
- Oblong wooden blocks, at least 14 x 14 x 30 cm

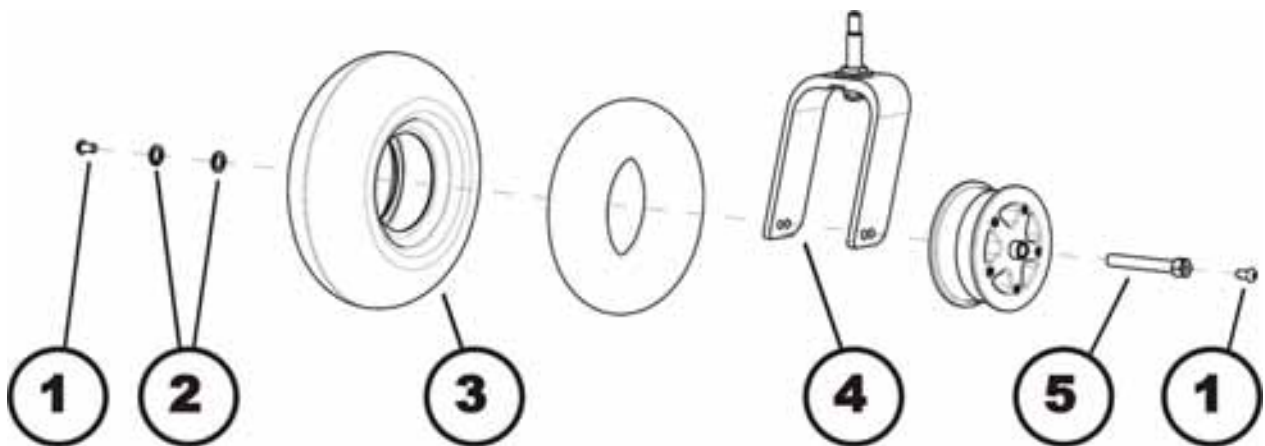

Removing the wheel

- Prop up the wheelchair on multiple wooden blocks with the help of a second person.
- Use the 5 mm Allen wrench to loosen and remove the hexagon socket head screws (1).
- Pull the axle (5) out laterally.
- Remove the complete wheel (3) from the front wheel fork (4).

Assembling the wheel:

- Assemble the parts in reverse order.
- When installing the wheel, pay attention to the correct direction of rotation.

7.17.4 Replacing a tire or inner tube in the front



WARNING: Danger of crushing!

The wheelchair is very heavy. Danger of injury to the hands and feet!

- Let a second person help you.

Danger of injury due to uncontrolled movement of the wheelchair!

- Switch the vehicle's power system off (ON-/OFF key).
- Engage the drive motors.
- Secure the vehicle against rolling away by placing wedges under the wheels.



Requirements:

- 5 mm Allen wrench
- Two oblong wooden blocks, at least 14 x 14 x 30 cm
- Repair kit for inner tube tires **or** a new inner tube
- Air pump or compressor
- Talcum powder

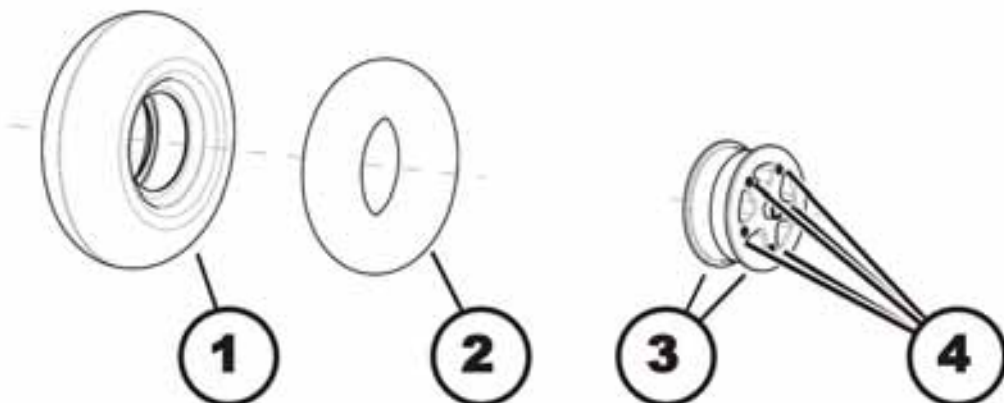

Removing a tire / inner tube:

- Uninstall the wheel as described in chapter 7.17.3.



CAUTION: EXPLOSION HAZARD!

On a vehicle with pneumatic tires, the wheel will explode if you do not let the air out of the tire before removing the wheel!

- Always allow the air to escape from the wheel before you remove it. Press the spring pin in the middle of the valve.

- Unscrew and remove the valve cap (2).
- Press the spring pin in the middle of the valve and allow the air to completely escape from the tire.
- Uninstall the wheel as described in chapter 7.17.3.

- Use a 5 mm Allen wrench to loosen the five hexagon socket head screws (4).
- Remove the inner ring and outer ring (3) of the rim from the tire (1).
- Remove the inner tube (2) from the tire.
- Replace defective or worn parts, or repair these parts.

Installing a tire:

- Insert the inner tube back into the tire.

**NOTE**

If the old tube is to be repaired and re-fitted and has become wet during repair work, powdering the hose with some talcum powder can simplify the fitting procedure.

- Re-position the rim halves (3) in the tire again. Make sure that the holes and threads for the screws are positioned exactly on top of each other.
- Inflate the inner tube with a little bit of air.
- Insert the five hexagon socket head screws on the inner side of the wheel and tighten them firmly.
- Check that the tire is positioned correctly on the rim.
- Inflate the tire to the prescribed pressure.
- Check once more that the tire is positioned correctly on the rim.
- Screw the valve cap back on.
- Re-install the wheel.

7.18 Drive wheels

7.18.1 Replacing the drive wheel

**WARNING: Danger of crushing!**

The mobility device is very heavy. Injury hazard to hands and feet!

- You should seek help from a second person.

Injury hazard caused by uncontrolled movement of the mobility device!

- Switch the power supply off (ON/OFF key).
- Engage the drive.
- Before raising the vehicle, secure the wheels by blocking them with wedges.

**Note**

In most cases the drive wheel is fixed to the wheel hub by means of five Allen screws. Only Trelleborg tyres are fixed by means of four Allen screws.

**Requirements:**

- 6 mm Allen key
- Long wooden blocks, min. 14 x 14 x 30 cm

**Removing the drive wheel:**

- Lift the mobility aid up on one side and get a second person to place a wooden block around 14 cm high underneath it so that the drive wheel is suspended freely.
- Loosen the four or five 6 mm Allen screws (1).
- Take the wheel (2) off the wheel hub.

Refitting the drive wheel:**NOTE**

Please ensure that the wheel is re-fitted on the same side and in the same running direction as removed.

- Refit the wheel in reverse order.

7.18.2 Replacing a tyre or inner tube



Note

There are three different types of tyres or inner tubes, and specific points must be observed for the replacement of each type.

It is easy to tell the difference between the tyre or inner tube types:

- Pneumatic tyres have black valve caps.
- Puncture-protected tyres have red valve caps
- puncture-proof tyres have no valves.

Please proceed in accordance with the appropriate chapter:

- Replacing pneumatic tyres – see chapter 7.18.2.1
- Replacing puncture-protected tyres – see chapter 7.18.2.2
- Replacing puncture-proof tyres – see chapter 7.18.2.3

7.18.2.1 Replacing pneumatic tyres



Note

Pneumatic tyres have black valve caps. Puncture-protected tyres have red valve caps



Requirements:

- 6 mm Allen key
- Two long wooden blocks, min. 14 x 14 x 30 cm
- Repair kit for inner tube tyres **or** a new inner tube.
- Tyre pump or compressor
- Talcum powder

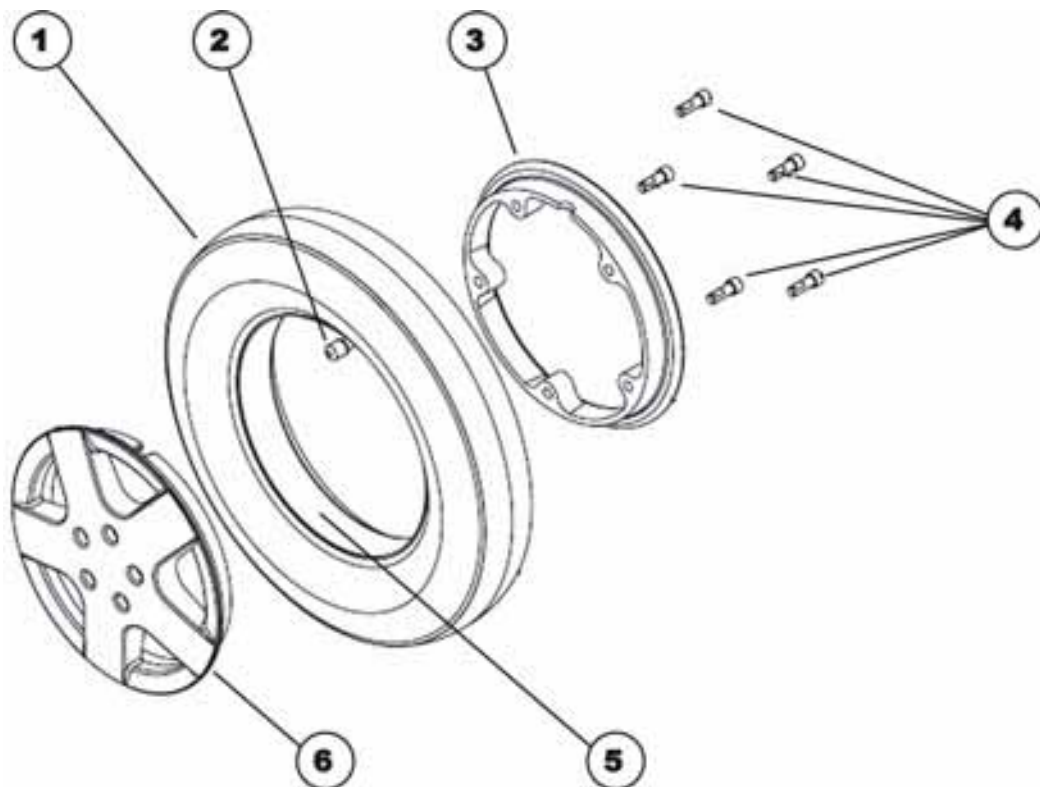

Removing the tyres:

- Remove the wheel as described in chapter 7.18.1.
- Unscrew the valve cap (2).



ATTENTION: Explosion hazard!

If the wheelchair is fitted with pneumatic tyres, the wheel can explode if the air is not released from the tyre before removing the wheel!

- *Always release the air from the wheel before you remove it. Depress the small tappet in the centre of the valve!*
-

- Press the spring pin on the valve and remove the air completely from the tyre.
- Undo the five 6 mm Allen screws (4) on the inside of the wheel.
- Release the inner (3) and outer rim ring (6) from the tyre (1).
- Remove the inner tube (5) from the tyre.
- Replace defective or worn parts or repair the parts.

Refitting the tyres:

- Refit the inner tube in the tyre.



NOTE

If the old inner tube is to be repaired and used again and has become wet during repair, installation can be facilitated by applying some talcum powder to the inner tube.

- Refit rim rings (3) and (6) to the tyre. Please ensure that the boreholes and thread for the screws are exactly above each other.
- Fill some air into the inner tube.
- Refit the five Allen screws on the inner side of the wheel and tighten them.
- Check the exact fit of the tyre on the rim.
- Inflate the tyre to the prescribed air pressure.
- Re-check the exact fit of the tyre on the rim.
- Screw the valve cap back on.
- Refit the wheel.

7.18.2.2 Replacing puncture-protected tyres

**Note**

Pneumatic tyres have black valve caps. Puncture-protected tyres have red valve caps

**Requirements:**

- 6 mm Allen key
- Two long wooden blocks, min. 14 x 14 x 30 cm
- Tyre pump or compressor
- Talcum powder

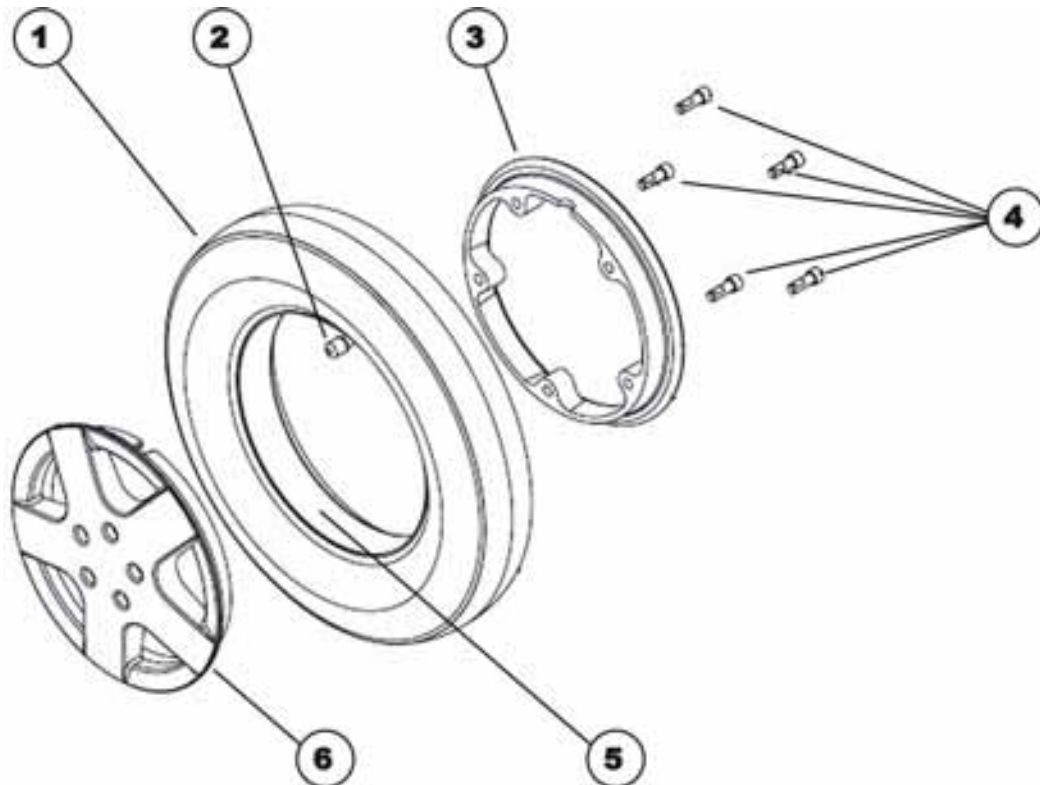
**Removing the tyres:**

- Remove the wheel as described in chapter 7.18.1.

**ATTENTION: Explosion hazard!**

If the wheelchair is fitted with pneumatic tyres, the wheel can explode if the air is not released from the tyre before removing the wheel!

- *Always release the air from the wheel before you remove it. Depress the small tappet in the centre of the valve!*

**CAUTION!**

Material damage hazard. The valve can become blocked by the puncture protection gel and be unusable!

- *During the following work you should always hold the valve up so that the puncture protection gel cannot enter the valve.*

- Remove the valve cover (2).
- Press the release pin in the valve inwards and evacuate all the air from the tyre.
- Undo the five 6 mm Allen screws (4) on the inside of the wheel.
- Remove the inner (3) and outer (6) ring of the rim from the tyre (1).
- Replace any defective or worn parts.

Refitting the tyres:

- Refit the inner tube in the tyre.

**Note**

If the old inner tube is to be repaired and re-used, and has become wet during repair, you can make replacement easier by sprinkling the inner tube with a little talcum powder.

- Refit rim rings (3) and (6) to the tyre. Please ensure that the boreholes and thread for the screws are exactly above each other.
- Fill some air into the inner tube.
- Refit the five Allen screws on the inner side of the wheel and tighten them.
- Check the exact fit of the tyre on the rim.
- Inflate the tyre to the prescribed air pressure.
- Re-check the exact fit of the tyre on the rim.
- Screw the valve cap back on.
- Refit the wheel.

7.18.2.3 Replacing puncture-proof tyres



Requirements:

- 6 mm Allen key
- Two long wooden blocks, min. 14 x 14 x 30 cm
- Three joiner's clamps with plastic caps
- Torque spanner 5 - 25 Nm (or similar)
- Talcum powder

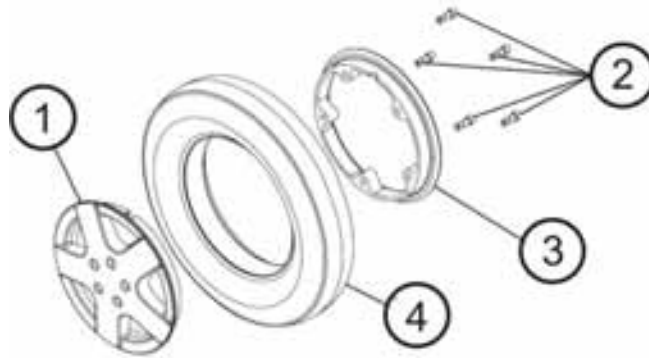

Removing the tyres:

- Remove the wheel as described in chapter 7.18.1.



ATTENTION: Explosion hazard!

There is considerable pressure in the tyre. Danger of injury! Parts can be thrown out and injure you if you do not secure the rim rings.

- *Secure the rim rings with joiner's clamps.*

- Secure the rim rings against unexpected discharge with three joiner's clamps. When doing so, ensure that you do not scratch the rims.
- Undo the five 6 mm Allen screws (2) on the inside of the wheel.
- Now loosen the joiner's clamps carefully and alternately until you can remove the rim rings without danger.
- Remove the inner (3) and outer (1) ring of the rim from the tyre (4).
- Replace any defective or worn parts.

Refitting the tyres:

- Refit the tyres to the rim in the reverse sequence.
- When fitting the rim rings together, ensure that the drillholes and threads for the bolts are placed exactly above each other.
- Place the joiner's clamps in position.
- Tighten the joiner's clamps alternately in small stages until the rim rings are precisely aligned.
- Tighten the Allen screws (2) to 18 Nm.

7.18.3 Replacing the drive wheel hub

**CAUTION!**

Possible material damage to mobility device! Collisions can be caused if the adjusting washers are removed during fitting work to the drive wheels!

Adjusting washers are often fitted between the drive shaft and the wheel hub to even out tolerances. If these adjusting washers are removed and not replaced again, collisions can be caused.

- *Always replace the adjusting washers exactly as they were before you started dismantling.*

**Requirements:**

- 19 mm socket spanner

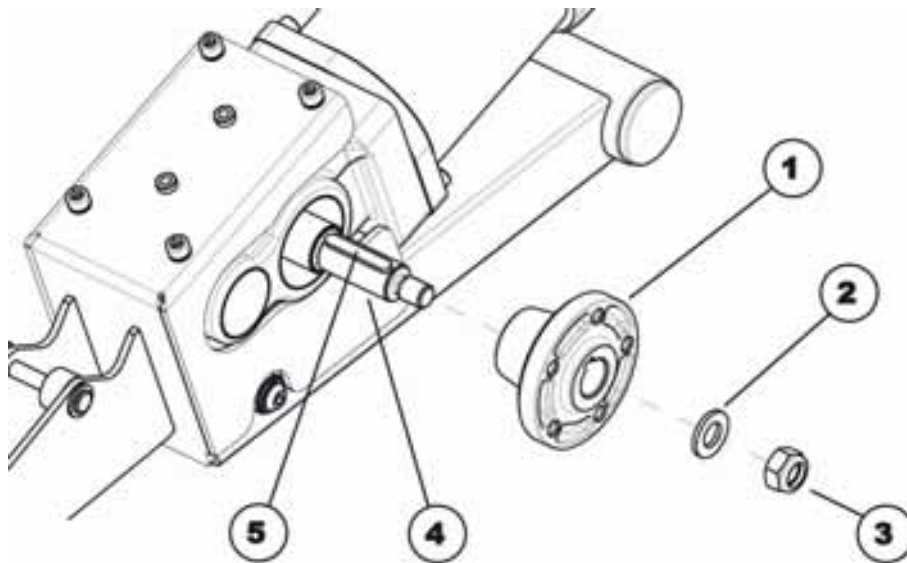
**Removing the drive wheel hub:**

- Loosen and remove the nut (3) with a 19 mm socket spanner.
- Remove the washer (2).
- Take the wheel hub (1) off the axle (4).
- Take the feather key (5) off the axle.

Refitting the drive wheel hub:

- Refit the drive wheel hub parts in reverse order.
- Use a thin film of lubricant to make pushing the wheel hub onto the axle easier.

7.19 Drive unit

7.19.1 Replacing the motor/transmission unit (Standard Storm⁴)

**WARNING: Danger of crushing!**

The mobility device is very heavy. Injury hazard to hands and feet!

- You should seek help from a second person.

Injury hazard caused by uncontrolled movement of the mobility device!

- Switch the power supply off (ON/OFF key).
 - Engage the drive.
 - Before raising the vehicle, secure the wheels by blocking them with wedges.
-

**ATTENTION: Danger of crushing!**

The motor gearbox unit is extremely heavy. Injury hazards to hands!

- Please note the high weight
-

**Requirements:**

- 5 mm Allen key
 - 6 mm Allen key
 - 19 mm socket spanner
 - long wooden blocks, min. 14 x 14 x 30 cm
-

Removing the motor/transmission unit:

- Remove the rear and the centre battery compartment cover as described in chapters 7.1.1 und 7.1.2.
- Pull the motor plug out of the power module.
- Open the cable clamps and expose the motor cable.
- Remove the drive wheel as described in chapter 7.18.1.
- Remove the wheel hub as described in chapter 7.18.3.
- Remove the splash guard as described in chapter 7.1.5.

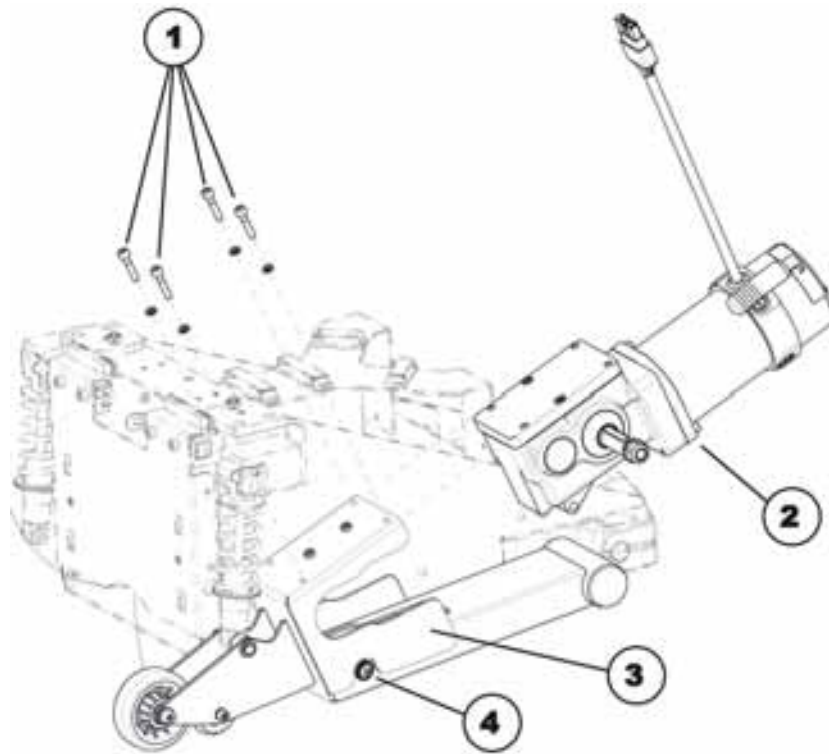

- Undo the four Allen screws (1) with a 5 mm Allen key.
- Remove the screws together with the Nord-Lock lock washers.
- Undo the Allen screw (4) with a 5 mm Allen key.
- Remove the screws together with the washers.
- Pull the motor/transmission unit (2) out of the mounting (3) in a forward direction. In doing so, please observe the high weight of the unit.

Refitting the motor/transmission unit:

- Replace the defective parts.
- Refit the motor/transmission unit in reverse order.
- To conclude, check all the mobility aid functions.

7.19.2 Replacing the carbon brushes (Standard motor)

Note

Always replace all the carbon brushes on both motors.

WARNING: Danger of crushing!

The mobility device is very heavy. Injury hazard to hands and feet!

- You should seek help from a second person.

Requirements:

- 5 mm Allen key
- 6 mm Allen key
- 10 mm socket spanner
- 19 mm socket spanner
- blade screwdriver
- long wooden blocks, min. 14 x 14 x 30 cm

Removing the carbon brushes:

- Switch off the mobility aid.
- Remove the drive wheels as described in chapter 7.18.1.

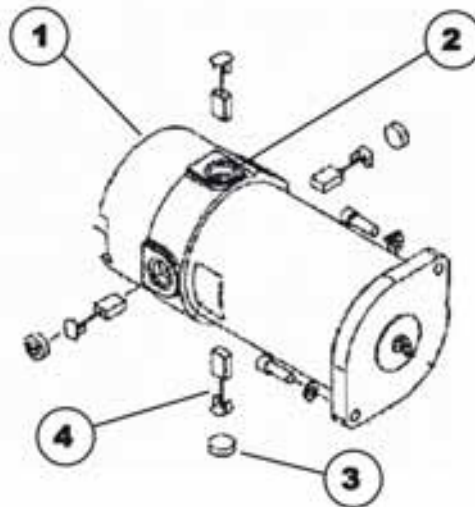

- Disengage the motor (1) by setting the engaging lever to “Push”.
- Loosen and remove all four plastic caps (3) using a blade screwdriver.
- Note the fixing position and location of the carbon brushes.

Note

Used carbon brushes need to be refitted exactly in the same position from which they were taken in order to guarantee optimum contact to the collector.

- Make a marking on the motor and the carbon brushes in order to guarantee correct refitting.
- Remove the carbon brushes completely from the mounting (2).
- Check the carbon brush and spring for the level of wear, broken components or discolouration.

Refitting the carbon brushes:

- Depending on the condition of the brush and the spring:
 - either replace the brushes in exactly the same position from which they were taken or
 - fit new brushes.
- Refit the plastic caps and tighten them firmly.
- Refit the drive wheels as described in chapter 7.18.1.

**Note**

The following procedure is necessary to run the carbon brushes in after replacement and thus guarantee maximum performance.

**WARNING: Risk of accidents!****Hazards to workers, surroundings and mobility device!**

- *Do not leave the mobility device unattended during the following procedure!*
 - *Secure the area.*
-
- Lift the mobility aid up on one side and get a second person to place a wooden block around 14 cm high underneath it so that the drive wheel is suspended freely.
 - Also repeat this on the other side of the mobility aid.
 - Allow the motors to run for an hour in forward direction.
 - Allow the motors to cool down for 30 minutes.
 - Allow the motors to run for an hour in reverse direction.
 - Lift the mobility aid off the wooden blocks.

7.19.3 Replacing Bowden cables and the clutch

**WARNING: Danger of crushing!**

The wheelchair is very heavy. Danger of injury to the hands and feet!

- *Let a second person help you.*

Danger of injury due to uncontrolled movement of the wheelchair!

- *Switch the vehicle's power system off (ON-/OFF key).*
- *Engage the drive motors.*
- *Secure the vehicle against rolling away by placing wedges under the wheels.*

**CAUTION: Danger of crushing!**

The motor / gearbox unit is very heavy. Danger of injury to the hands!

- *Pay attention to the heavy weight.*

**Requirements:**

- 5 mm Allen wrench
- 6 mm Allen wrench
- 13 mm socket wrench
- Oblong wooden blocks, at least 14 x 14 x 30 cm

**Uninstalling Bowden cables:**

- Loosen the locking nuts (1) of the Bowden cables on the clutch lever.
- Loosen the adjustment nuts (2) of the Bowden cables on the clutch lever.
- Pull the Bowden cables out of the lever unit.

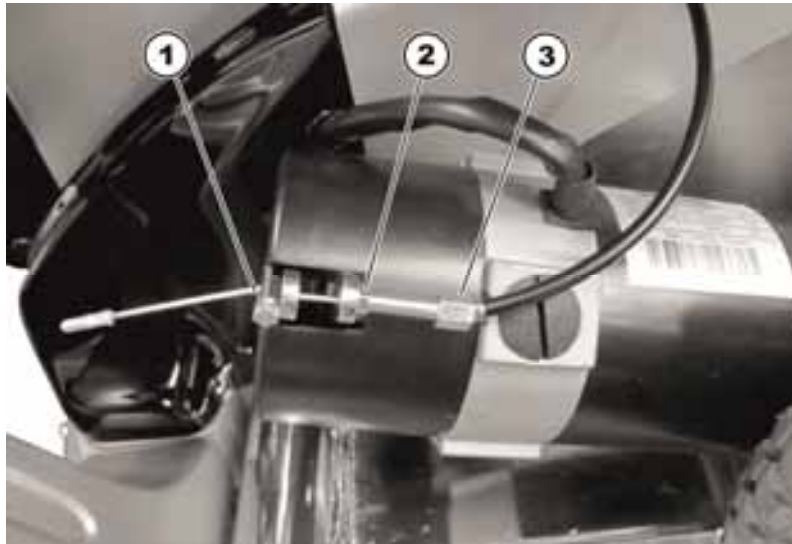

- Loosen the screw of the pull-out protection (1).
- Remove the pull-out protection from the Bowden cable.
- Loosen the locking nut (2) of the Bowden cable on the motor.
- Loosen the adjustment nut (3) of the Bowden cable on the motor.
- Pull the Bowden cable out of its holder on the motor.
- Repeat the procedure on the other motor.

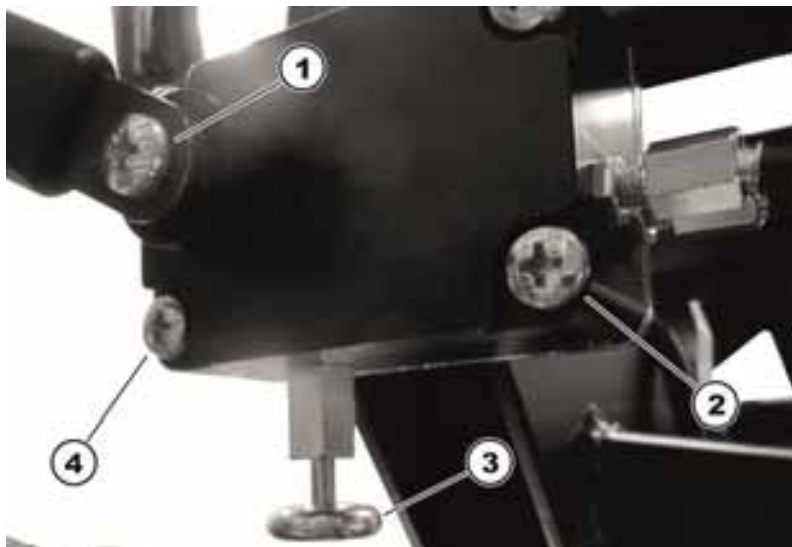
**Uninstalling the lever unit of the clutch:**

- Loosen the screw of the clutch lever (1).
- Remove the clutch lever.
- Loosen the 4 screws (2) and (4) of the lever unit.
- Remove the lever unit from the fixation.

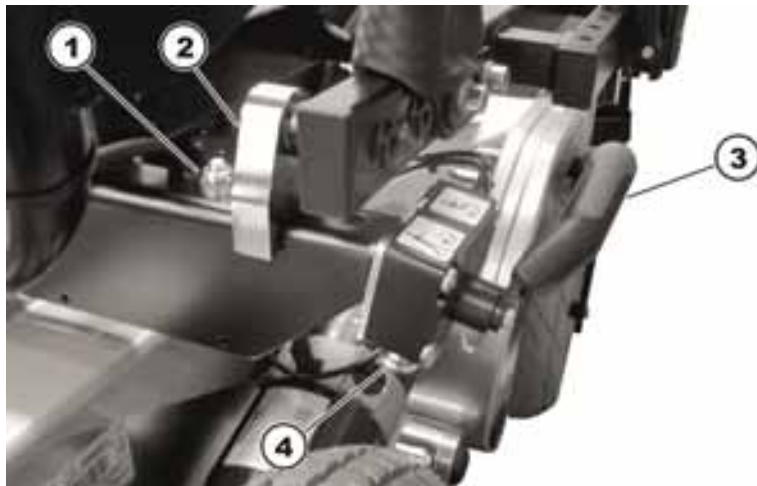

Uninstalling the fixation bracket of the lever unit:

- Loosen the hexagon socket head screws underneath the seat frame. One hexagon socket head screw is screwed into the nut (1). The other hexagon socket head screw is screwed into one of the frame supports.
- Pull the fixation bracket out of the seat frame.



Installing Bowden cables, lever unit and fixation bracket:

- Replace the defective components.
- Install Bowden cables, lever unit and fixation bracket in reverse order.
- Adjust the clutch by loosening the counter nut (1) and turning the adjustment nuts (2) on the lever unit.
- The last step is to test all functions of the vehicle.

7.20 Rear wheel suspension

7.20.1 Replacing the rear wheel suspension



WARNING: Danger of crushing!

The mobility device is very heavy. Injury hazard to hands and feet!

- *You should seek help from a second person.*

Injury hazard caused by uncontrolled movement of the mobility device!

- *Switch the power supply off (ON/OFF key).*
- *Engage the drive.*
- *Before raising the vehicle, secure the wheels by blocking them with wedges.*



Requirements:

- 5 mm Allen key
- 6 mm Allen key
- T40 torx wrench
- 13 mm socket spanner
- 19 mm socket spanner
- blade screwdriver
- long wooden blocks, min. 14 x 14 x 30 cm

Dismantling the wheel suspension:

- Remove the rear and the centre battery compartment cover as described in chapters 7.1.1 and 7.1.2.
- Remove the rear light cover as described in chapter 7.1.4.
- Pull the motor plug out of the power module.
- Open the cable clamps and expose the motor cable.
- Remove the drive wheel as described in chapter 7.18.1.
- Remove the wheel hub as described in chapter 7.18.3.
- Remove the splash guard as described in chapter 7.1.5.
- Remove the motor/transmission unit as described in chapter.

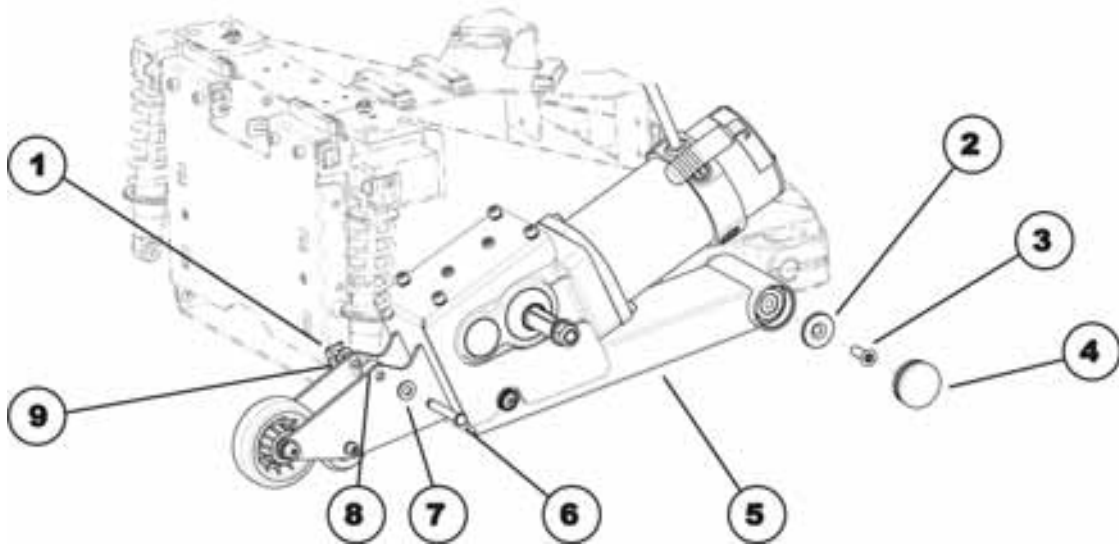

- Loosen and remove the nut (1) from the hexagon-socket head bolt (6) on the spring.
- Remove the washer (9).
- Remove the hexagon-socket head bolt (6). In doing so, please pay attention to the washer (8) and the spacer (7).
- Remove the plastic cover (4).
- Loosen and remove the torx screw (3).
- Remove the spacer (2).
- Remove the entire wheel suspension (5) from the axle.

Refitting the wheel suspension:

- Refit the parts in reverse order.
- To conclude, you should always carry out a trial run to test the vehicle functions.

7.21 Replacing the strut

7.21.1 Removing the suspension strut

**Note**

Invacare® always recommends replacing both struts in order to ensure that the mobility aid works perfectly.

**WARNING: Danger of crushing!**

The mobility device is very heavy. Injury hazard to hands and feet!

- You should seek help from a second person.

Injury hazard caused by uncontrolled movement of the mobility device!

- Switch the power supply off (ON/OFF key).
- Engage the drive.
- Before raising the vehicle, secure the wheels by blocking them with wedges.

**Requirements:**

- 4 mm Allen key
- 6 mm Allen key
- 13 mm socket spanner
- long wooden blocks, min. 14 x 14 x 30 cm

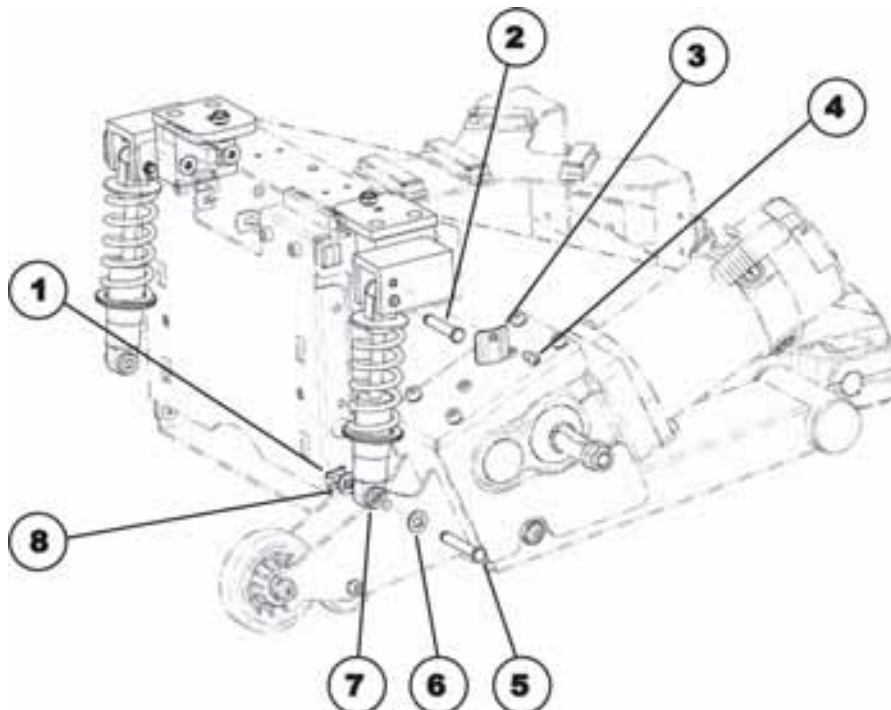

Dismantling the strut:

- Remove the rear and the centre battery compartment cover as described in chapters 7.1.1 and 7.1.2.
- Remove the drive wheel as described in chapter 7.18.1.
- Loosen and remove the nut (1) from the hexagon-socket head bolt (5) on the spring.
- Remove the spacer (8).
- Remove the hexagon-socket head bolt (5). In doing so, please pay attention to the washer (7) and the spacer (6).
- Loosen the Allen screw (4) with a 4 mm Allen key.
- Remove the Allen screw (4) together with the cover plate (3).
- Remove the pin (2). In doing so, please pay attention to the washers and spacers.
- Remove the strut.

Refitting the strut:

- Refit the parts in reverse order.
- To conclude, you should always carry out a trial run to test the vehicle functions.