

BODY BUILDERS INSTRUCTIONS

The Incomplete Vehicle Document (IVD) is supplied with each incomplete vehicle, and provides information that should be used by intermediate and final stage manufacturers in determining conformity to applicable Federal Motor Vehicle Safety Standards (FMVSS). The IVD also includes information which must be followed in order to ensure that Environmental Protection Agency (EPA) and California emissions certification requirements and NHTSA Fuel Regulations are met.

The Body Builders Book contains information that may be used in addition to the IVD for any manufacturer making alterations to an complete/incomplete vehicle. No alteration should be made to the incomplete vehicle which either directly or indirectly results in any component, assembly or system being in nonconformance with any applicable Federal Motor Vehicle Safety Standard or Emission Regulation. Intermediate and final stage manufacturers should be familiar with all Federal Motor Vehicle Safety Standards and Emission Regulations and aware of their specific responsibilities as manufacturers.

For further assistance contact Upfitter Integration at: 1 (800) 875-4742

Section 0 – General Instructions

Check for proper clearance between body members and chassis components which may in any way affect the reliability and performance of the vehicle by developing abrasion and wear points from moving parts or degradation from extreme environment or thermal exposure or may increase interior noise.

Check headlamp aim and all vehicle illumination systems for proper operation when the vehicle has been completed. Re-aim headlamps when necessary. Check for proper operation of windshield washer, wipers and defroster system. In no case should any alterations affect the function, physical or mechanical properties, environment or vital spatial clearances of the components, assemblies or systems.

Extreme care must be taken when working on vehicles which have been equipped with Powertrain Control Module (PCM), Vehicle Control Module (VCM), Sensing and Diagnostic Module (SDM) (Air Bag Control Module) and ABS Control.

Do not mount any components with large magnets, such as stereo speakers, in the area of the drivers seat due to the Sensing and Diagnostic Module (SDM).

The Sensing and Diagnostic Module (SDM) located under the driver seat and S.I.R. sensor at the lower radiator support, can not, under any circumstances be moved from their present mounting locations.

Check for proper clearance between body members and chassis components which may in any way affect the reliability and performance of the vehicle by developing abrasion and wear points from moving parts or degradation from extreme environment or thermal exposure or may increase interior noise. Any attachments must consider chassis components for jounce and rebound motion at maximum GVW.

Welding

CAUTION: Fuel tank and fuel lines must be drained and all vapors purged to ensure non-combustible mixture before any welding, brazing or soldering.

If arc-welding is employed on the chassis or body parts or components which could be damaged by welding temperatures must be removed or adequately shielded. Some examples are brake lines, fuel lines and fuel tank assembly, electrical wiring, electronic modules, sensing and diagnostic module under drivers seat and S.I.R. sensor under radiator support. To avoid electronic component damage, disconnect battery (batteries); disconnect the negative cable first, followed by the positive. To reconnect cables; connect the positive first, then the negative.

When welding low carbon steel side rails, crossmembers and brackets, emphasis is placed upon weld application techniques to avoid stress risers that may adversely affect frame operating stresses. Note that some of the frame sections are made of high strength-low alloy steel that could be adversely affected by heating due to welding. Also prior to welding, the area to be welded and surrounding area must be cleaned of all frame protective coating.

After welding, when parts are cool, carefully inspect wiring and electrical components for shorts or other damage which could draw excessive currents and possibly cause an electrical system short when the battery is reconnected. Also, assure that the fuel systems and especially the fuel lines are not damaged or distorted from the welding heat. Apply protective coating to areas where coating was removed.

Service and service replacement parts for your add-on systems may not be available from a GM dealer. Those installing aftermarket systems should provide information as to where and how to obtain service.

Labels

All labels on the vehicle (any message applied to the vehicle or vehicle component that informs, instructs, or warns) must appear on the completed vehicle so the user can read them easily and without obstruction.

NOTE: In order to be in compliance with FMVSS 208, **no** other label shall be installed on the same side of the sunvisor as the Inflatable Restraint Caution (Air Bag) Label.

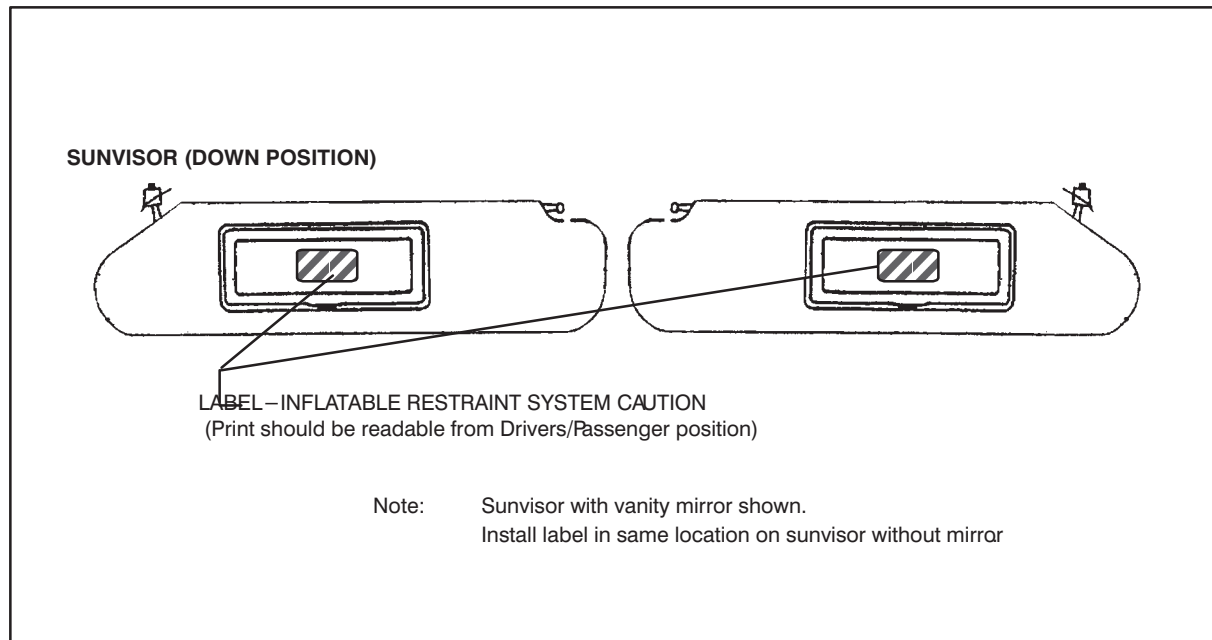

Section 1 – Body

Accessory items such as refrigerator, hot water heater, furnace, etc., which operate on liquid propane gas should be located and protected to prevent exposure to any flame.

Body structures, interior and accessory arrangements must be designed into the vehicle to provide for proper load distribution on both axles and not to exceed any gross axle weight ratings. Lateral load equalization must also be maintained. The resultant Center of Gravity of the unladen vehicle must be within the limits tabulated in the FMVSS 105 section of the Incomplete Vehicle Document.

Body insulation provided by General Motors should not be removed. This includes any thermal or underbody heat shields. This insulation is provided to protect the vehicle body and occupants from excessive heat and/or provide noise attenuation. Any replacement material internal to the occupant compartment may have to be certified for MVSS 302 standard on flammability. Some areas of specific interest are:

- Underbody exhaust, muffler and tailpipe shields and insulators.
- Rear load floor interior insulation.
- Front floor interior insulation.
- Dash mat insulation.
- Engine cowl insulation-interior and exterior.
- Engine cover insulation.

Conversions

Conversions which remove the roof bow above the front doors must provide equivalent tie-in between door pillars.

A minimum of 10° departure angle should be maintained if frame and/or body is extended.

If body builder installs seating other than that supplied with vehicle, it is the body builder's responsibility to ensure that the seating and restraint systems comply with FMVSS requirements. The restraint systems supplied with the vehicle were designed to accommodate the seating reference points and seat travel of the original equipment seats only.

Air Conditioning

For additional information refer to **Engine - Section 6**.

NOTE: Air conditioning systems using R-134A refrigerant are equipped with metric fittings to prevent interchange with R-12 refrigerant components. Do not interchange R-134A components, refrigerant oil or service equipment with R-12 components, refrigerant oil or service equipment.

Rear Air Conditioning

This unit may be equipped with A/C quick-connect fittings on the liquid tube (high pressure) and the suction (low pressure) return tube. These fittings are designed to accept matching Aeroquip connecting fittings attached to pre-charged lines. This allows a one time only connection to the O.E.M. charged A/C system without having to discharge, evacuate and recharge for the connection of a rear A/C system. These quick connects must be used for warranty coverage of the A/C system.

A modification to the A/C system which causes the A/C plumbing lines to increase in length (such as the addition of a rear after-market evaporator and blower assembly) will necessitate the following changes:

- Lubrication – PAG refrigerant oil must be added to rear system to provide lubrication for compressor. Refer to Service Manual for specifications.
- Refrigerant – Add R-134-A refrigerant to system based on sizing of new tubes, hoses and evaporator. Contact your A/C supplier for recommended charge.
- Label – Revise/modify GM charge label (located on the front face of evaporator) from factory recommended charge for a front system only to body builder's new recommended dual system per SAE J639. This is important for servicing the A/C system so that the technician knows the correct amount to add to the modified system.

- Heater/Defroster – No modifications should be made to the heater/defroster system or coolant supply which could affect compliance to FMVSS 103.

Section 2 – Frame

Hole drilling, welding, modifications, or alterations to the frame assembly are the responsibility of persons performing these operations. These same individuals assume complete responsibility for frame assembly, reliability, performance after alterations and compliance to applicable FMVSS requirements.

The following procedures and specific precautionary instructions are recommended for proper installation of special bodies and/or equipment on GM frames. Failure to follow these recommendations could result in serious damage to the basic vehicle.

Flanges

Do not drill holes in frame flanges:

- Within 20 mm (0.75 in.) of radius tangent and 25 mm (1.0 in.) of raw edge.
- Larger than 12 mm (0.50 in.).
- Closer to each other than twice the hole diameter.

Holes

Holes to mount brackets, supports, and out-riggers must be drilled in the vertical side web with the following restrictions:

- Material between edge of hole and inside of upper or lower flange must not be less than 37 mm (1.50 in.) for low carbon steel (36,000 PSI yield).
- The minimum edge distance between any two (2) holes must be larger than twice the diameter of the larger hole.
- No holes should exceed 20 mm (0.75 in.) in diameter.
- All holes should be drilled in the frame using appropriate drilling practice and safety precautions.

Alterations

If the wheelbase is modified, the alterer must take responsibility for compliance with affected motor vehicle safety and emission standards and for warranty on items such as driveshafts, universal joints, center bearings and rear transmission tailshaft, transfer case and transmission case fractures, output shaft bushings, bearings, brakes, fuel systems and any other related component failures. Additionally, the customer

must be alerted in the modifier's owners manual that parts for the reworked area are not available through the General Motors service parts system.

Shear Plate Attachments

Attachments of shear plates should be accomplished by using existing manufacturing holes already available.

When additional holes are required for shear plate attachment, they should be no larger than 20 mm (0.75 in.) in diameter. Holes are to be drilled no closer than 63.5 mm (2.5 in.) apart. For holes drilled forward of the rear axle, centers are to be no closer than 63.5 mm (2.5 in.) from the top or bottom flanges and no closer than 89 mm (3.5 in.) from any suspension attachments. For frame holes drilled rearward of the rear spring hanger bracket, hole centers are to be no closer than 51 mm (2.0 in.) from the top or bottom flange and no closer than 89 mm (3.5 in.) from suspension attachments.

Required large holes such as 20 mm (75 in.) diameter or larger, should be kept to a minimum required opening. Tubes should be welded in place if holes in excess of 25 mm (1.0 in.) diameter are required.

Trailer Towing

The Incomplete Vehicle Document specifies that the CG location be within certain limits. The Body Builder must use all appropriate data.

Note to Body Builder/Final Stage Manufacturer: Failure to keep body and payload CG at least 26 inches forward of centerline of rear axle will result in degradation of trailer towing capacity. Consult the Trailer Towing Guide to determine maximum tongue load for your vehicle.

Section 3 – Front Suspension

See chassis data information for clearances and assistance in calculating trim heights.

Since there is a large variation in completed vehicle front weight due to differences in body weight and equipment, care must be taken not to exceed the GAWR/GVWR. Also, the front suspension alignment must be checked and reset if necessary after the vehicle is completed. Caster and camber should be set with reference to the "A" dimensions.

See Truck Service Manual for complete alignment procedure, specifications and measurement of the "A" dimension under "Diagnosis and Front Alignment" section.

Section 4 – Rear Suspension

Due to differences in body weight and equipment, care must be taken not to exceed the GAWR/GVWR.

Clearance to body should be provided for the suspension, axle, driveshaft and tires under the following conditions: (1) Axle in full jounce against the metal-to-metal stop, (2) Axle at 4.5° roll with one side of axle in full jounce at the metal to metal stop and (3) Axle at design position. Allowance for the tire chain clearance shown on a maximum grown tire must allow for (1.66 in.) clearance to the sides of the tire and (2.5 in.) to the top of the tire. Be sure sufficient clearance is provided for suspension, axle and tire and wheel through full vertical travel (up and down).

Pipes, wiring, conduits and any other related components must not be placed where they cross the path of motion of the rear axle, driveshaft, axle brake pipes, hoses, spring or tires. Such crossing could result in rupture, wear-through, or separation due to normal axle motion.

NOTE: Notification to the consumer may be required in certain states if tire chains cannot be used.

See chassis data information for additional clearances and for assistance in calculating trim heights.

Section 5 – Brakes

See Truck Service Manual for brake specifications.

Due to the critical nature of brake systems, anyone making modifications or alterations must assume complete responsibility for system reliability, performance and certification to FMVSS 105.

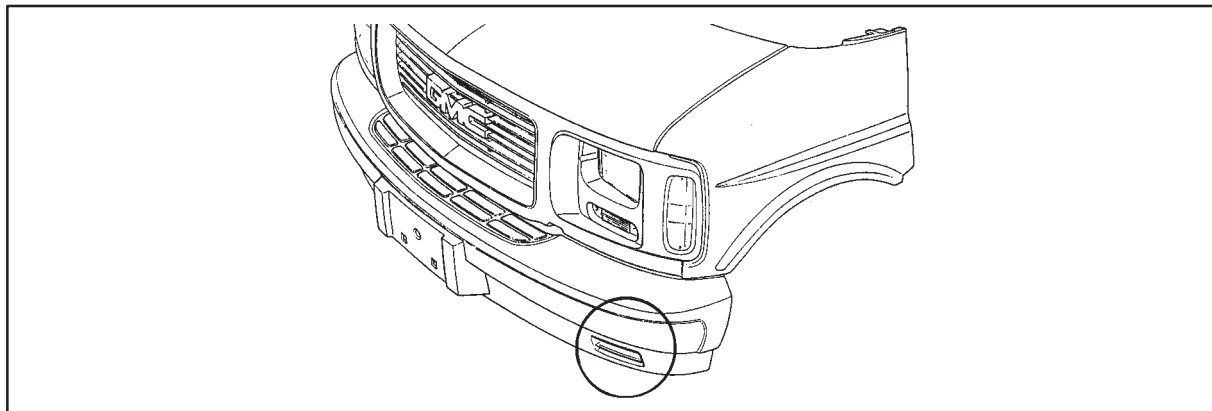

All G10 and some G20 models are equipped with front air dams below the front bumper as shown in the illustration. These air dams are equipped with brake cooling openings as shown. These openings should not be obstructed by the addition of any accessories that would impede the flow of air to the front brakes.

It is mandatory that no change be made to the brake master cylinder location, brake pedal push rod length or pedal position.

Ensure that hydraulic brake system is free of air and hydraulic leaks. Bleed brakes if required, following procedures as outlined in truck chassis service manual. Ensure that vacuum booster system or hydroboost system is functional and free of leaks.

Check master cylinder fluid level and fill as necessary. Use only DOT3 Fluid from a sealed container. Delco Supreme 11 is recommended. (Refer to Owner's Manual)

Check power steering fluid level for models equipped with hydroboost brake. (Refer to Owner's Manual)

Added floor covering or carpeting must not restrict service or parking brake pedal travel from released position to full pedal travel.

No body part or chassis-mounted component may be located within 2.0 in. of brake hose routing in all wheel and axle positions. All exhaust system components must also have a minimum of 2.0 in. clearance to brake hoses in closest positions. (Be sure to account for brake hose travel with suspension). **Note:** Heat shielding is likely required with clearances even greater than 2.0 in. Keep the brake fluid temperature below the boiling point of water under all operating conditions.

Body builder is to verify that the brake warning switches are operative. (The brake warning switch on models equipped with vacuum-hydraulic brakes is located adjacent to the master cylinder vacuum unit.) This includes the brake system differential pressure. (The parking brake actuator switch is mounted on the park brake apply mechanism which is mounted on the L.H. body side inner under the instrument panel).

The park brake system is equipped with an automatic adjuster. **Do not separate the park brake cables unless the apply mechanism is blocked out** (See Service Manual). The adjuster will wind in the cable until it can no longer be reconnected if not blocked (pinned).

Section 6 – Engine

For additional information refer to **Body - Section 1**.

Air conditioning and auxiliary belt-driven equipment installation recommendations:

No alterations or additions to the accessory drive belt system will be warranted on either multiple belt systems or serpentine belt systems.

The serpentine belt type of drive is designed as a total system, incorporating a single poly-V belt and an automatic tensioner. In this type of system, degrees of pulley wrap, belt tension, and pulley alignment are very critical factors. Modification is not recommended.

The fan and fan clutch that come with the vehicles are matched to the equipment and conditions encountered in normal operation. Substitution of the fan and/or fan clutch may affect cooling performance. A substitute fan may be subjected to excessive stresses and might break. Substitution is therefore not allowed.

The incorporation of an aftermarket air conditioning system could have the following consequences:

- Vehicle/engine/coolant overheating in certain geographical areas that normally experience high ambient temperatures.
- Restrictions to engine cooling fan airflow resulting in higher fan blade stress.
- Inadequate air conditioning performance unless system capacity is enough to cool the interior space of the completed vehicle.

Due to the critical nature of the accelerator system, anyone making modifications or alterations assumes complete responsibility for system reliability, performance and compliance to FMVSS 124. Caution must be exercised so that the accelerator cable routing is unchanged.

- Do not use accelerator cable or clips to route wires, harnesses or other cables. Cable sheath must be clipped so as not to pinch inner cable. Cable must not be loose in clip allowing sheath to move when accelerator pedal is applied and released.
- Cable must not be subjected to kinking or routing across any sharp edges.
- Cable routing must be perpendicular to the surface of the front-of-dash at the dash fitting. No objects or routings should force cable to have a bend at the dash fitting. Flexible components (hoses, wires, conduits, etc.) must not be routed within 2.0 in. (50 mm) of moving parts or accelerator linkage unless routing is positively controlled.
- Caution must be taken so that the accelerator pedal mounting and location remains unchanged. Guidelines for accelerator pedal locations are as follows:
 - a. Ensure that the accelerator can freely operate from idle to wide-open throttle position and return. Make sure that the pedal will not hang up on any nearby items such as carpets, floor, screws, wiring harnesses, etc. Engine cover should have at least one inch (25 mm) clearance to side of accelerator pedal with the carpet mat installed.

- b. Accelerator to brake pedal relationship has been designed to provide minimum driver movement and **should not be altered in any way.**

The gasoline engine induction and/or ignition system is certified in compliance with the Federal Vehicle Emission Standards. Any alterations to the systems or components could void compliance and render the vehicle illegal. Systems include:

- Fuel system – Port Fuel Injection and associated tubes, hoses and pipes, air cleaner outside air hose and spacer heat stove and heat stove pipe, fuel pump and inlet manifold, fuel vapor canister.
- Exhaust system.
- Ignition system distributor and initial spark timing setting, spark plugs and spark plug wires.
- Crankcase ventilation system.

The diesel engine induction and injector pump system is certified to be in compliance with the Federal Vehicle Emission Standards and/or Noise Standards. Any alterations to the system or components could void compliance and render the vehicle illegal. Systems include:

- Fuel system – Injection pump, injector lines and injectors, fuel return hoses and pipes, air cleaner, outside air hose, fuel pump, fuel filter, fuel heater assembly and intake manifold.
- Exhaust system.
- Crankcase pressure regulation system.

External engine components such as air cleaner, crankcase pressure regulator valve, alternator, injection pipes, fuel return hoses from injectors, exhaust manifolds, oil fill pipe, etc. must be provided with sufficient clearance for engine roll and torque.

When a vehicle is equipped with a electronic fuel injection (EFI) engine, it has an engine control module ECM/PCM/TCM or VCM. This ECM/PCM/TCM or VCM must be maintained at a temperature below 185°F at all times. This is essential if the vehicle is put through a paint baking process. The ECM/PCM/TCM or VCM will become inoperative if its temperature exceeds 185°F. Therefore, it is recommended that temporary insulation be placed around the ECM/PCM/TCM or VCM during the time the vehicle is in a paint oven or undergoing another high temperature process.

Section 7 – Transmission

This product is equipped with a neutral/park start safety switch mounted on the transmission which interfaces with the vehicle starter circuit. The starter will only operate with the shift lever in the neutral or park position.

Models equipped with brake-transmission shift interlock (BTSI) require full application of the regular brakes before shifting from park when the ignition key is in the run position.

Section 8 – Fuel and Exhaust

Fuel Systems

Due to the critical nature of sealing the fuel system, anyone making modifications or alterations to the existing system must assume complete responsibility for the system reliability, performance and compliance to FMVSS 301 and emission standards.

The completed fuel system is certified to be in compliance with the Federal and California Vehicle Emission Standards. Any alterations to systems or components and their environment could void compliance. Systems include:

- Fuel tank, metering unit, lines including purge control solenoids and canister or canisters.

Environment Includes:

- Heat sources, heat shields, system component relocation.

For these reasons,

NO ALTERATION OF THE FUEL SYSTEM IS RECOMMENDED

If the fuel system is received from the manufacturer in an incomplete condition, certification becomes the responsibility of the intermediate or final stage manufacturer.

Fuel Fill

Fuel tank filler pipe location should be so situated and constructed as to prevent gasoline vapor from emitting to vents of pilot flamed devices and to body and engine compartment air inlets.

It is recommended that when mounting the fuel filler pipe assembly and vent hose that a minimum of 3.0 in. clearance be provided to any body component to prevent contact between hoses and/or mating parts and that retention be provided to ensure routing and prevent failure due to wear and fatigue. Filler pipe and vent line must have a gravity fuel flow to tank at all times; no fuel traps are allowed. Alterations of fuel line routings could affect the completed vehicle and are, therefore, not desirable. The complete fuel system must comply with FMVSS 301 as well as Federal and C.A.R.B. vapor emission requirements.

This vehicle is equipped with concentric fuel fill and vapor lines made from special materials in order to meet the federal and California evaporative emission standards. Changing the length, material, routing of the fuel fill will require evaporative emission validation by the final stage manufacturer.

Fuel Lines

Fuel line routing precautions:

- 12 in. minimum clearance to exhaust system is required or a metal shield must be provided.
- Fuel lines should be clipped to (every 600 mm or less) to prevent chafing. Metal clips must have rubber or plastic liners.
- Use corrosion resistant steel tubing with short sections of approved electrically conductive hose to connect components. Steel tube ends should be beaded for hose retention. Fuel supply is pressurized by an in-tank pump. Coupled hose or electrically conductive quick-connect must be used.

All engines require a fuel return system which returns excess fuel from the injection pump and injector nozzles back to fuel tanks. Care should be taken that these lines are not blocked nor their hoses pinched. The engine may run poorly or stall if these lines are restricted or blocked.

All gasoline engine vehicles are equipped with fuel evaporative emission control equipment which is certified to be in compliance with the Federal or applicable California vehicle emission standards. Alterations to fuel tank and metering unit, lines, canister or canisters, canister filters, canister purge control valves, relay switches, tank auxiliary vent valve, engine speed controller, or other devices/systems are therefore not allowable since vehicle adherence to C.A.R.B. and Federal regulations may be affected.

Diesel powered vehicles incorporate water drain provisions in the fuel system. These valves are only to be opened when removing water and contaminants from the fuel system.

Fuel Tank

The tank must have a minimum clearance of 2 in. top, front, rear and side to body and other supports.

Tank may be pressurized to 1.25 PSI maximum to check for final line leakage or for forcing fuel through the system. Pressures greater than this amount may be detrimental and affect tank durability.

The use of auxiliary fuel tanks is not recommended. If an auxiliary fuel tank is added, the alterer must take responsibility for compliance with affected motor vehicle safety and emission standards. Also, if an auxiliary fuel tank is added to a gasoline-powered vehicle, the fuel must be drawn through a pipe at the top of the tank (balance line between tanks is not permitted). Venting of auxiliary tank to be provided via purge canister and not to atmosphere. Gasoline fueled vehicles are now equipped with a fuel pump return line. If an auxiliary tank is added, the tank selector valve must include port which returns fuel to the tank from which the fuel is being drawn.

Similarly, addition of another fuel line for an auxiliary fuel user (such as a generator) will require emission revalidation.

In gasoline engines the fuel pump is located in the fuel tank. The battery must be disconnected before starting any work on the fuel system.

Gaseous Fuel Conversions

All truck gasoline engines may be converted to use liquified petroleum gas (LPG) or natural gas (NG). Some conversions may cause harmful effects to the engine. Such fuel systems may require assurances from alternate fuel system manufacturers and/or installers that the equipment will not cause damage to the engine or the exhaust system.

In the use of dual fuel systems, the intermediate or final stage manufacturer should strictly adhere to the manufacturer's procedures for switching from gasoline to gaseous fuel operation. Improper switching procedures may result in overheating and damage to the exhaust system and the vehicle. The gaseous fuel tank should not be mounted in an enclosed area of the vehicle, such as the passenger compartment, etc., and the system should be vented to the outside of the vehicle. In addition, vehicles converted to gaseous fuels should not be stored in enclosed places such as garages. Further, General Motors cautions purchasers that the design, location and installation of any type of fuel storage system involves significant technical and engineering considerations and that these statements on gaseous fuel conversions should not be interpreted to be an approval by General Motors of any modification to the original equipment fuel system.

Conversions to gaseous fuel should be made in conformance with applicable Federal and State regulations. Removal of emission-control components and/or the addition of gaseous fuel systems which could damage or reduce the longevity of those components, could cause the mechanical and emission performance warranty to be voided.

Exhaust System

Particular care should be taken to prevent the possibility of exhaust exposure to vehicle occupants in units completed by body builders. Holes and openings through the floor and all other parts of the body must be permanently and adequately sealed by the body builder to avoid exhaust intrusion into any occupant area. If it is necessary

to change the exhaust outlet location, the exhaust discharge must be unobstructed and directed away from occupant areas. Alteration of the exhaust outlet or its position may increase exhaust noise and render the vehicle illegal in those areas with pass-by noise regulations. All vehicles >10,000 lbs. GVWR come under Federal noise regulations, vehicles ≤10,000 lbs. GVWR are regulated by various state and local regulations; see those regulations for rules, test procedure and noise levels permitted.

Check for proper clearance between body members and chassis components which may in any way affect the reliability and performance of the vehicle by developing abrasion and wear points from moving parts or degradation from extreme environment or thermal exposure or may increase interior noise. Any attachments must consider chassis components for jounce and rebound motion at maximum GVW.

Tail pipe outlet location must be tested statically and with the vehicle in motion to ensure that exhaust gases do not enter through side or rear windows or under body seams and holes. Auxiliary power plants should also be tested under the same conditions. Tail pipe exit ahead of rear wheels is not recommended.

Check for leaks in exhaust systems and repair as required.

NOTE: The manifold joint take down pipe and converter assembly incorporating oxygen sensors is designed to suit OBD II requirements, which are dependent upon specific gas leakage rates at the joints. Ideally this assembly should not be disturbed during the body manufacturing process.

Exhaust gas temperatures can exceed 1600°F under extreme operating conditions, with pipe surface temperatures slightly less than this. Extreme care must be used when placing body components in the proximity of the exhaust system so as not to exceed the rated temperature limits of the components. Due to variants in underbody configurations of the vehicles, General Motors is not in a position to make recommendations on how to insulate or design components in the proximity of the exhaust system.

Each manufacturer must make temperature checks of critical areas and adjust his design accordingly, or provide shielding to ensure safe operation of body components.

The same can be said for the engine compartment. Obviously there will be additional heat radiated from the engine. How much is retained in the area will depend on how well the area is ventilated in your individual designs. Here again, temperature checks of interior areas surrounding the engine should be made to determine if your insulation is adequate. This is the same engineering practice General Motors has followed on our complete vehicles incorporating these exhaust systems.

Exhaust system materials are selected and tested to withstand the operating environment of the vehicle. Do not modify the exhaust system in any way. The tail pipes are made of 409 aluminized stainless steel.

Heat shields are mounted to the chassis, underbody and/or exhaust system components (tailpipe).

Section 9 – Steering

Check power steering fluid level and system operations. (Refer to Owner's Manual)

Steering wheel and horn pad must not be altered or replaced.

The steering column mast jacket is not to be altered.

The steering column must be locked or pinned to prevent rotation when the steering gear or column-to-gear intermediate shaft is disconnected. Damage to the inflatable restraint control wire can result if this is not done (See Service Manual).

Section 10 – Tires

Check wheel lug nuts for proper torque; specifications are provided in the Owner's Manual.

Substitution of tires of greater capacity than those offered as original equipment by vehicle manufacturer is not approved for use on original equipment wheels. Any usage of higher capacity tires must be accompanied by higher capacity wheels. However, the wheel offset and distance from centerline of rim to wheel mounting face must be the same as the replaced original equipment wheel to ensure proper wheel bearing loading and clearance of tires to body and chassis components.

Increasing tire and wheel capacity does not increase vehicle GVW ratings.

It is recommended that tire chain clearance guideline from the Society of Automotive Engineers, J683 be adhered to in designing rear wheelhouse clearance.

Check tires and inflate to recommended tire pressure according to the tire pressure information provided in Owner's Manual and tire inflation label provided with vehicle.

Any substitution of tires may affect Speedometer/Odometer accuracy, tire wear, fuel economy, ride and handling and stopping distances.

Section 12 – Electrical Battery and Battery Cables

The vehicle battery should be located and positioned to make use of the existing battery cables. If the battery requires relocation and longer cables are required, a propor-

tionately larger gauge wire must be used. If in relocating the battery the negative ground cable is attached to frame rail, a cable of similar gauge must be provided between the frame rail and the engine. This is required due to the heavy electrical loads imposed by the starting circuit. To ensure proper operation of the battery cables the following chart on length, gauge and materials must be strictly adhered to.

Combined Length of Positive and Negative	
Cable Gauge	Cable in Inches (Copper)
4	66
2	107
0	170

Battery Installation

The battery and cable installation, provided by the body upfitter, must comply with the following guidelines. Non-compliance may result in a failure of the vehicle electrical component system, the shutdown of the engine or the possibility of fire.

1. The cables must not contact any sharp edge(s), in either the normal (stored) or slid (maintenance) position (school bus application).
2. The cables must not be bent in a radius of smaller than 10 times the cable diameter. Insulation failure can occur if this happens.
3. The cable must be supported by clips spaced at a distance of not more than 250 mm. In this clipping, they shall not have a free movement that will allow rubbing on any vehicle component, either fixed or moveable.
4. All clips used must be of the rubber-lined type, not rubber dipped.
5. Do not splice the battery cables. Cable modifications can result in vehicle starting problems and loss of other key systems.
6. The cables must be clipped to the battery tray such that the cable pull loads are not transferred into the battery posts due to slide tray movement. Failure to do so can result in loose terminals, poor starting or battery failure. Battery acid leakage could result around posts not properly relieved of strain.
7. The cable attachments at the battery terminal must not cause undue strain at these connections. There should be no sharp bends in the cables adjacent to the connections. The cables should be routed down from the terminals rather than horizontally from the terminals to prevent a lever action that may loosen connections. Terminal corrosion inhibitors and other coatings should not be applied to the sealed electrical contact areas. Terminal torque of the sealed terminal shall be 10/20 N•m freedom, 14/20 N•m linehaul.
8. Mounting Base (Tray):
The tray should be of a substantial material sufficiently reinforced to resist flexing

and cracking. The tray must provide firm, continuous support of the battery and not amplify vibration levels. There must be no protrusions or projections in the tray or mountings that would damage the battery. Cantilevered mountings are not recommended and the tray should be mounted flat so as not to aggravate electrolyte spillage or lead fatigue. A rounded lip of adequate height to ensure stiffness and retention should be provided around the perimeter of the tray. With the battery mounted in a vehicle, a static force of 22 Kg applied to a 6.54 sq. cm. area at any corner should not move the battery any more than .25 mm.

Battery trays are supplied with the chassis. In the case of motor homes and diesel school buses, the trays are secured to the frame rail. The trays shipped on the rails may be relocated to other areas on the vehicle, keeping in mind the recommendations noted above.

For other units, the tray is supplied on the radiator support.

9. Freedom Battery:

The hold-down must be able to prevent the battery movement relative to the mounting base or hold-down. Torque at the battery hold-down shall be 15/20 N•m (133-177 lbs. in) at the base clamp or 2.3/4.5 N•m (20-40 lbs. in.) at the top bar. A bottom hold-down centrally located at the sides of the battery is recommended.

10. Location:

The battery should be located in a well ventilated area where a temperature build-up does not occur. The location should also provide protection to the battery to prevent damage from foreign objects. The ends of the battery in the area of the vent ports should be free of obstructions so that the gasses generated during charging can be freely dissipated into the atmosphere.

11. Accessibility:

The hold-down should be convenient for tools and hands so that personal injury does not occur. There should be clearance at the insulated and grounded terminals so that wrenches can be used without accidental grounds or shorts occur. Terminal polarity markings, warning labels and test hydrometer should be visible. The battery "ground" connection must be readily accessible for disconnection, as required for vehicle electrical service requirements.

12. Tilt Angles:

For normal vehicle operation (at GVW), the battery should not be tilted (0°). For installation or removal, it should not be necessary to tip or tilt the battery in excess of 40°. This is to prevent acid spillage. For short duration vehicle shipment, do not tilt the battery more than 19° from the horizontal.

13. Temperature:

The temperature of the electrolyte should not exceed 52°C. Infrequent peak temperatures to 75°C can be tolerated in soak situations only. Shielding may be required to protect the battery from a source of excessive heat.

14. Battery Storage:

Today's vehicles have several electronic devices which result in very small but continuous current drains on their batteries, commonly referred to as "parasitic" loads. Vehicles that are not used for an extended period of time may develop extremely discharged and/or permanently damaged batteries resulting from these parasitic loads. Discharged batteries can freeze at temperatures as high as 20°F causing permanent damage.

To alleviate this condition, check to make sure the green dot is visible, recharge as necessary, then disconnect the negative battery cable on vehicles which are not going to be in service within a 30 day period. If this is not possible, batteries should be periodically recharged (every 30-60 days) until the green dot is visible.

NOTE: The ignition switch must be off when connecting or disconnecting battery cables or hangers (jumper cables). Failure to do so may overstress or damage the ECM/PCM/TCM, VCM or other electronic components.

Modifications/add-on wiring must be carefully reviewed to ensure compatibility with the base vehicle wiring by reviewing system schematics, wire routing paths, harness connections, etc. Due to the wide range of modifications that may be required for vocational needs, it is not feasible for the O.E.M. to take into account all potential revisions. For this reason, any person modifying existing vehicle wiring must assume responsibility that the revisions have not degraded the electrical system performance. Any add-on wiring must be properly fused and routed to prevent cut, pinch, chafe problems, and exposure to excessive heat. Care must be exercised that existing vehicle interfaces do not have their current load capabilities exceeded, and that the respective control devices are not overloaded. Added wire size should be at least as large as the the wire to which it is attaching in order to maintain fuse protection.

A Packard electric wiring repair kit is available through Kent-Moore (GM P/N 12085264, Kent-Moore P/N J38125-4). This kit contains instructions, tools and components for making repairs to wiring harness components. This kit would also greatly assist in accomplishing necessary add-on wiring such as body marker lamps, so that system reliability/durability is maintained.

Electrical wiring components can be obtained through your authorized GM dealer. Many Packard Electric components are also available through Pioneer Standard Company (1-800-PACKARD). Pioneer may also be able to assist in making necessary wiring additions by providing custom wiring stubs or jumpers to your specifications.

Fusible Link Repair Procedure:

1. Cut damaged fusible link from wiring harness assembly splice.
2. Strip insulation from harness wire as required to splice on new fusible link.
3. Fabricate a new fusible link wire approximately 6 to 8 in. long from the same wire size as the original link. (Acceptable fusible link material will be imprinted with the wire size and the wording to identify it as fusible link. Fusible link cable is not the same as normal vehicle wiring.)
4. Terminate fusible link harness wire with a suitable compression splice clip, and solder with an electrical grade rosin core solder. Wrap splice area with tape to provide electrical insulation, as well as mechanical strain relief at the splice.
5. Strip, terminate, solder, and insulate remaining end of fusible link with appropriate termination to be compatible with the rest of the electrical system.
6. For further information, refer to the instruction manual in the wiring repair kit referenced elsewhere in this section.

Accessory Power Supply Feeds

For power requirements to service additional devices to be added by body builder/up-fitter, the power supply source must be from the studs on the underhood electrical center mounted on the left hand shear wall in the engine compartment.

A junction block has been provided behind the drivers side 'B' pillar. Both switched and unswitched power junction terminals are available (See Owner's Manual for compatibility). All additional loads should utilize these terminals.

NOTE: A ground stud has also been provided above the junction block.

Section 13 – Cooling

To provide satisfactory engine cooling and A/C performance, the following conditions must be met:

1. Do not locate any large objects such as batteries, spare tires, lights/sirens, etc., in front of the radiator core, A/C condenser or grille. They restrict air flow into the radiator core and influence fan blade stress and/or A/C head pressure.
2. Grille opening size, configuration and the external baffles provided should not be altered in any manner. Any reduction in cooling ability may adversely affect engine/transmission performance.
3. Fan clutches not conforming to the original equipment specifications may not operate correctly and may stay "on" continuously, never come on, or cycle on and off excessively. This may result in a reduction of fuel economy, engine overheat at times, or annoying cycling.
4. Heavy duty cooling equipment is required when air conditioning, auxiliary belt driven equipment, snow plows, winches, etc. are installed.
5. Continuous coolant flow is necessary from the heater connection on engine to the heater connection on radiator or water pump in order to control transmission oil temperatures during closed thermostat (warm-up) operation. Do not alter this flow as it may result in premature engine or transmission failure.
6. If a heater unit is not installed in the vehicle or a heater shut-off valve is required, a line connecting the heater connection on the engine to the heater connection on the radiator or water pump must be installed. When a shut-off valve is required in heating system, it must be teed into the system in such a manner as to maintain continuous flow between engine heater connection-radiator heater connection at all times.

Do not over fill coolant recovery or surge tank containers.

Be sure to add coolant to system after adding capacity to system heaters. The use of environmentally friendly long life coolant is required.

G (114/214/217/314/317)(05/06) General Arrangement

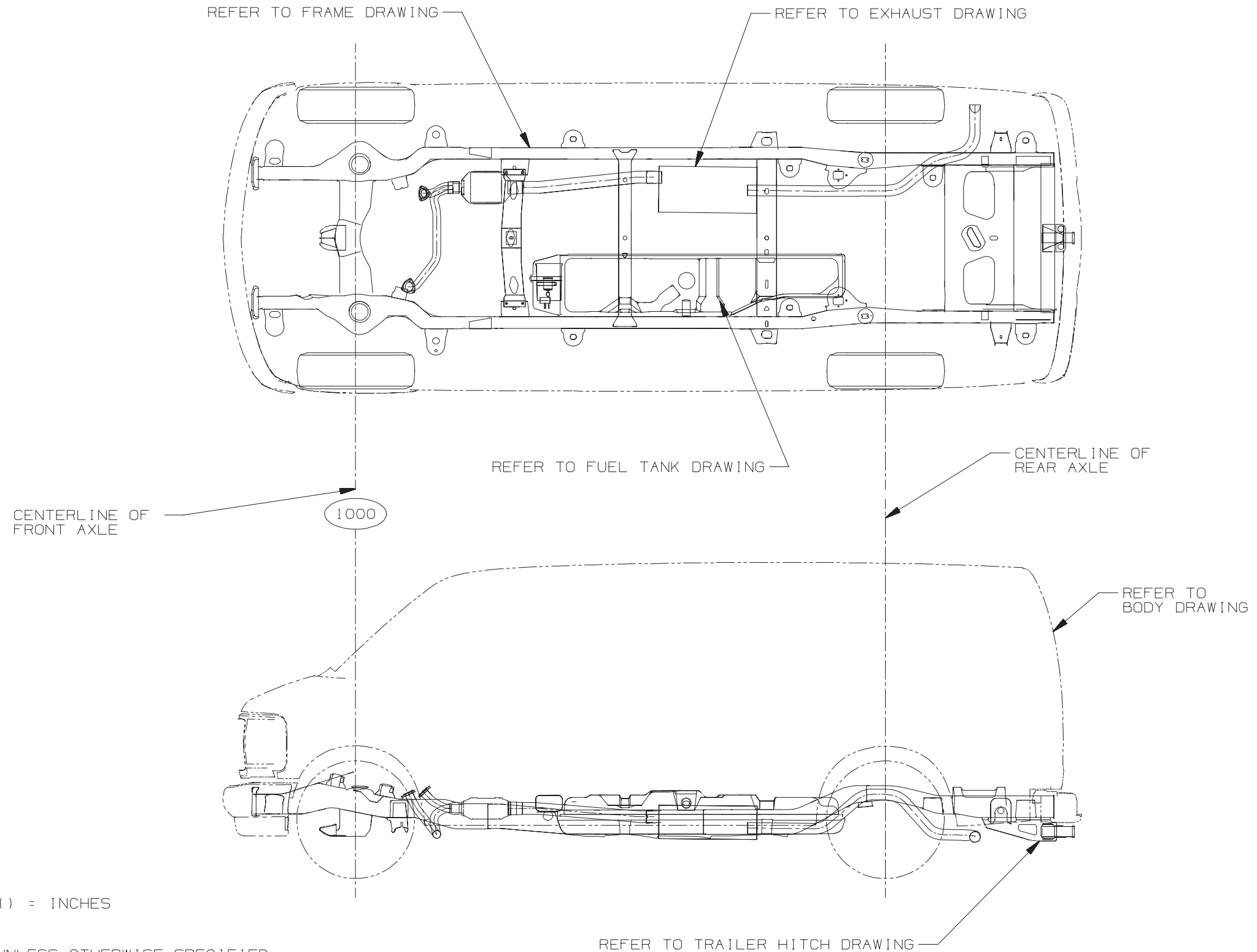

G (114/214/214)(05/06) 135" Wheelbase, Exterior, 5, 8 or 12 Passenger

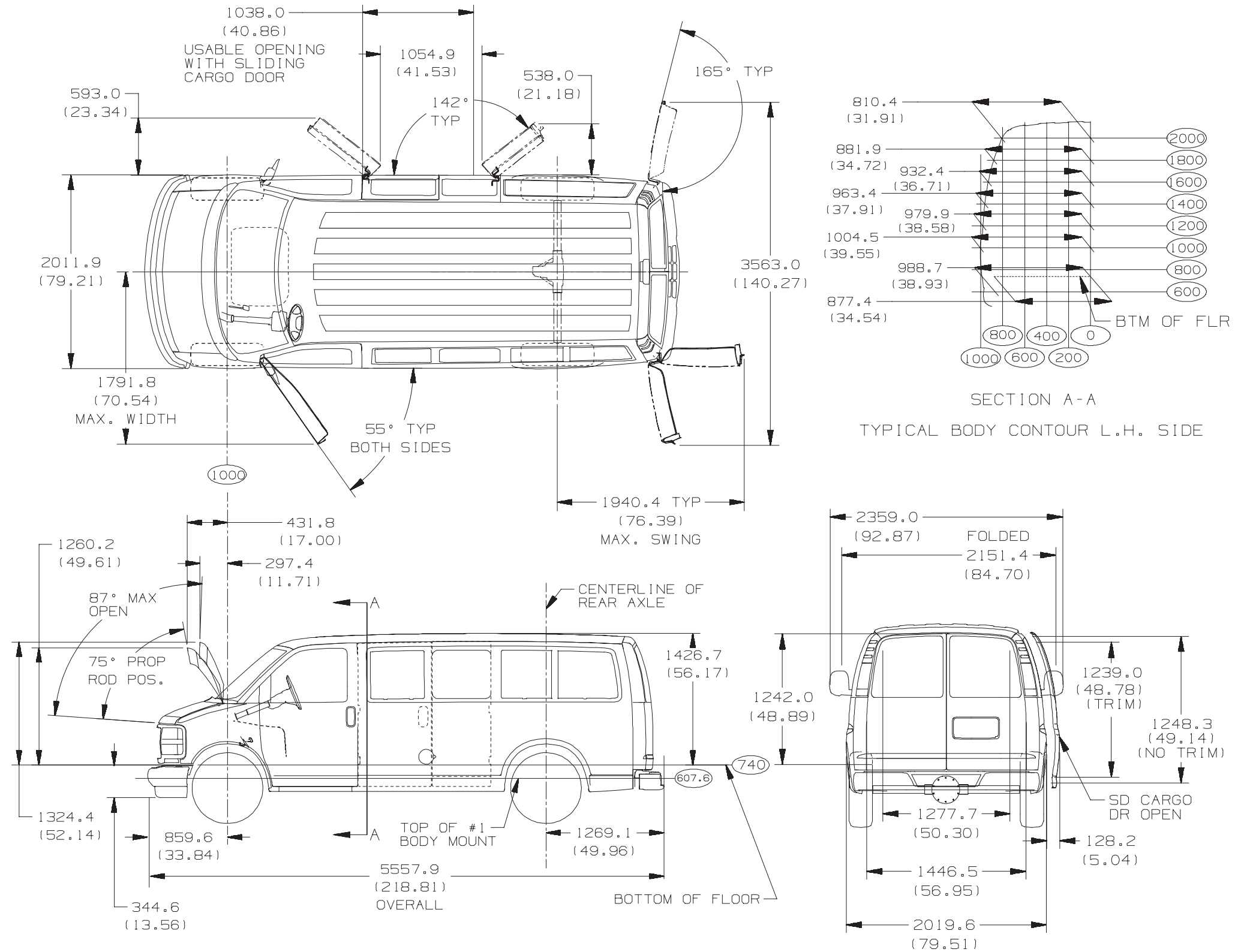

G (114/214/314)(05/06) 135" Wheelbase, Interior, 5, 8 or 12 Passenger

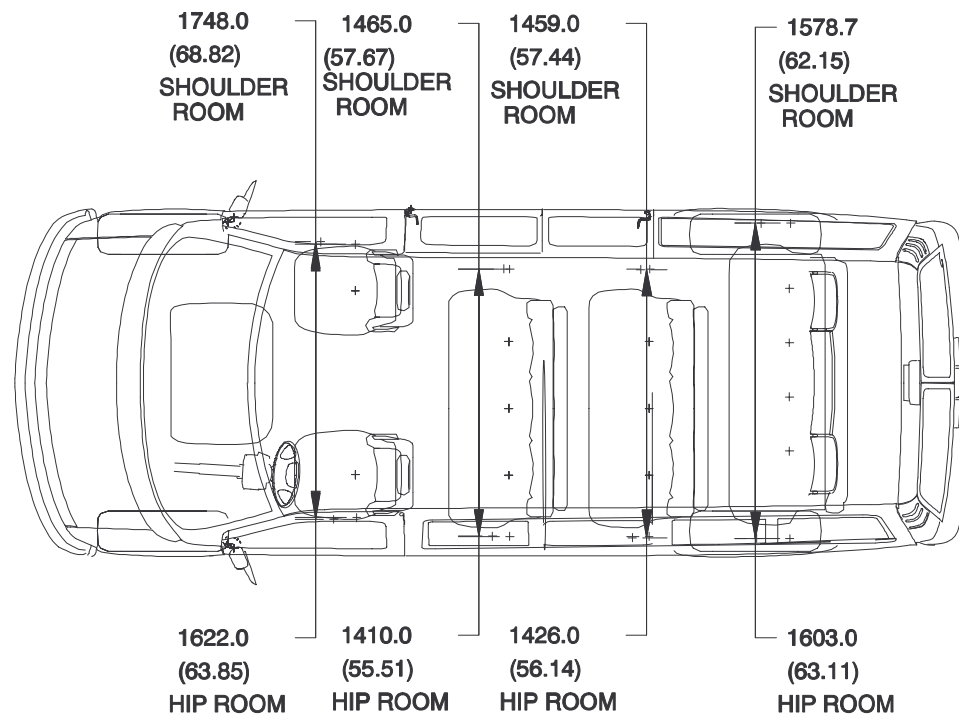

H-POINTS FOR 5,8 OR 12 PASSENGER 135" W/B

	SEAT ROW 1	SEAT ROW 2	SEAT ROW 3
PASSENGER (3 PASS BENCH)	(3 PASS BENCH)	(3 PASS BENCH)	(4 PASS BENCH)
L=2115.0 H=1160.0 W=533.0	L=3003.0 H=1153.5 W=238.5	L=3816.0 H=1153.5 W=238.5	L=4629.0 H=1153.5 W=546.0
DRIVER	L=3003.0 H=1153.5 W=-148.5	L=3816.0 H=1153.5 W=-148.5	L=4629.0 H=1153.5 W=-81.0
L=2115.0 H=1160.0 W=-533.0	L=3003.0 H=1153.5 W=-535.5	L=3816.0 H=1153.5 W=-535.5	L=4629.0 H=1153.5 W=-395.0

NOTE: CUTAWAY H-POINTS FOR DRIVER AND PASS SAME AS ABOVE.

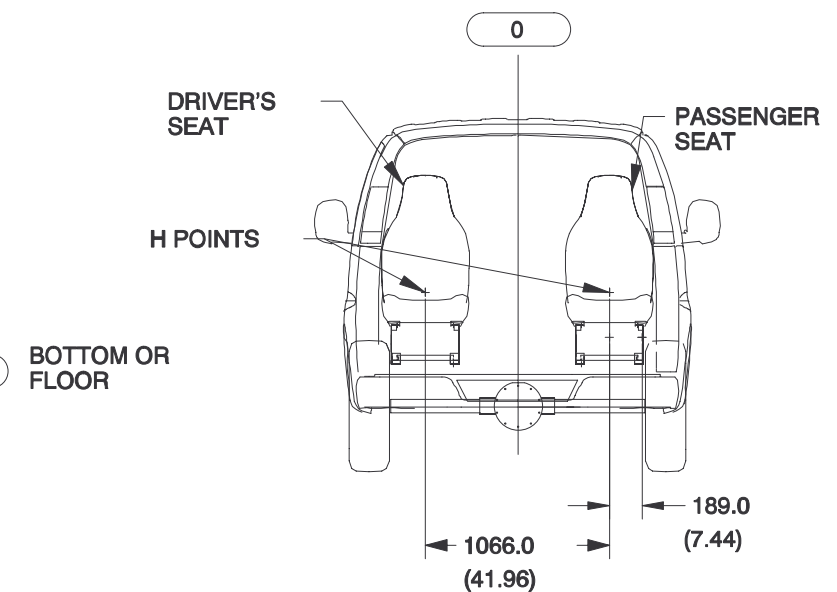
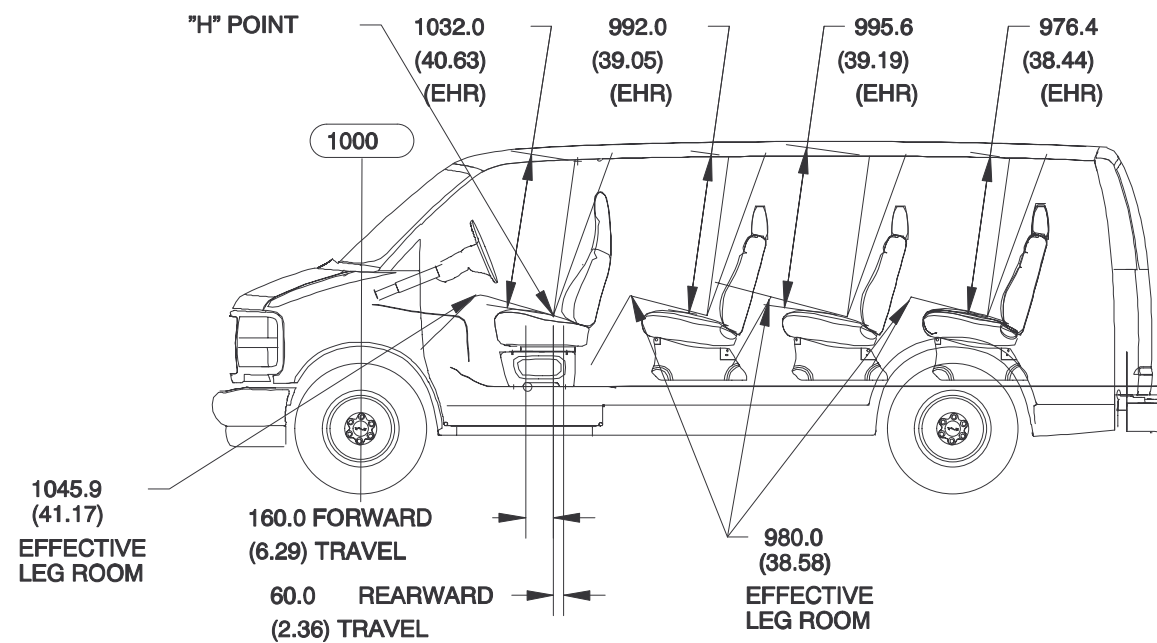

G (217/317)(05/06) 155" Wheelbase, Exterior

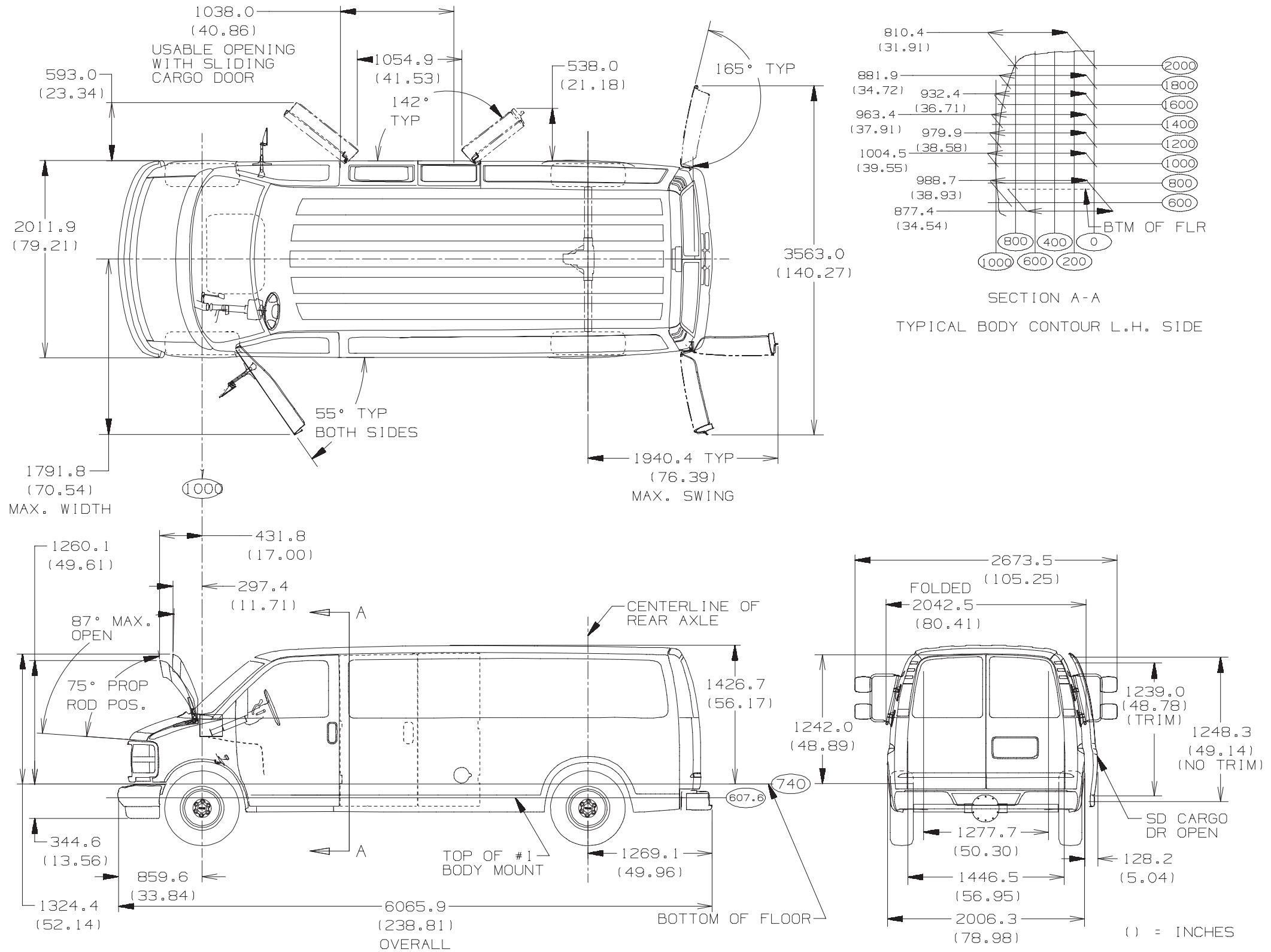

G (217/317)(05/06) 155" Wheelbase, Interior, 5, 8 or 12 Passenger

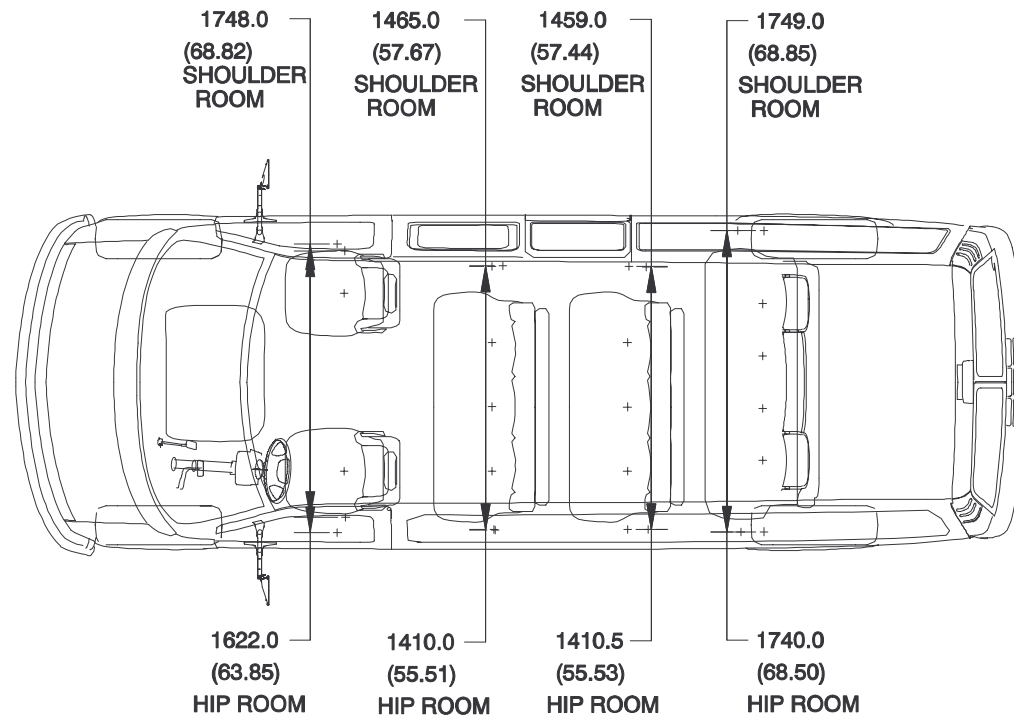

H-POINTS FOR 8 OR 12 PASSENGER 155" W/B

	SEAT ROW 1 PASSENGER (3 PASS BENCH)	SEAT ROW 2 (3 PASS BENCH)	SEAT ROW 3 (4 PASS BENCH)
L=2115.0	L=3003.0	L=3816.0	L=4629.0
H=1160.0	H=1153.5	H=1153.5	H=1166.0
W=533.0	W=238.5	W=238.5	W=470.5
	L=3003.0	L=3816.0	L=4629.0
	H=1153.5	H=1153.5	H=1166.0
	W=-148.5	W=-148.5	W=156.5
DRIVER	L=3003.0	L=3816.0	L=4629.0
L=2115.0	H=1153.5	H=1153.5	H=1166.0
H=1160.0	W=-535.5	W=-535.5	W=-470.0
W=-533.0			

NOTE: CUTAWAY H-POINTS FOR DRIVER AND PASS SAME AS ABOVE.

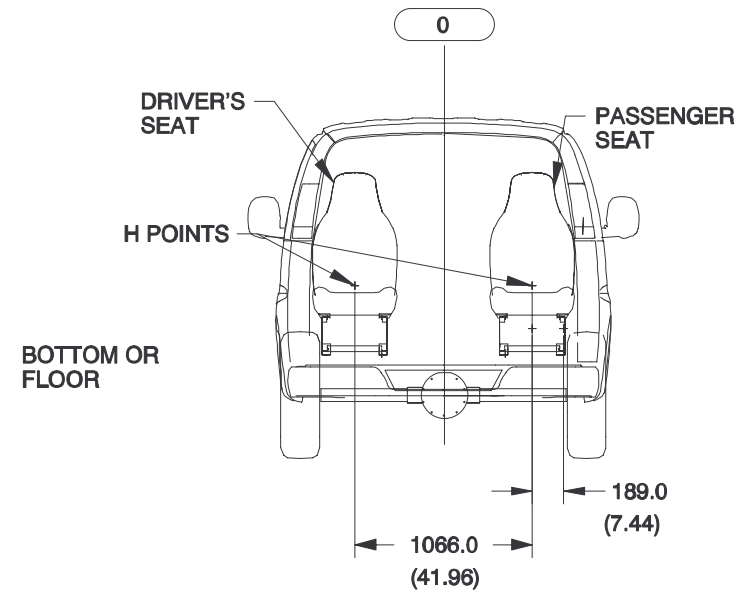
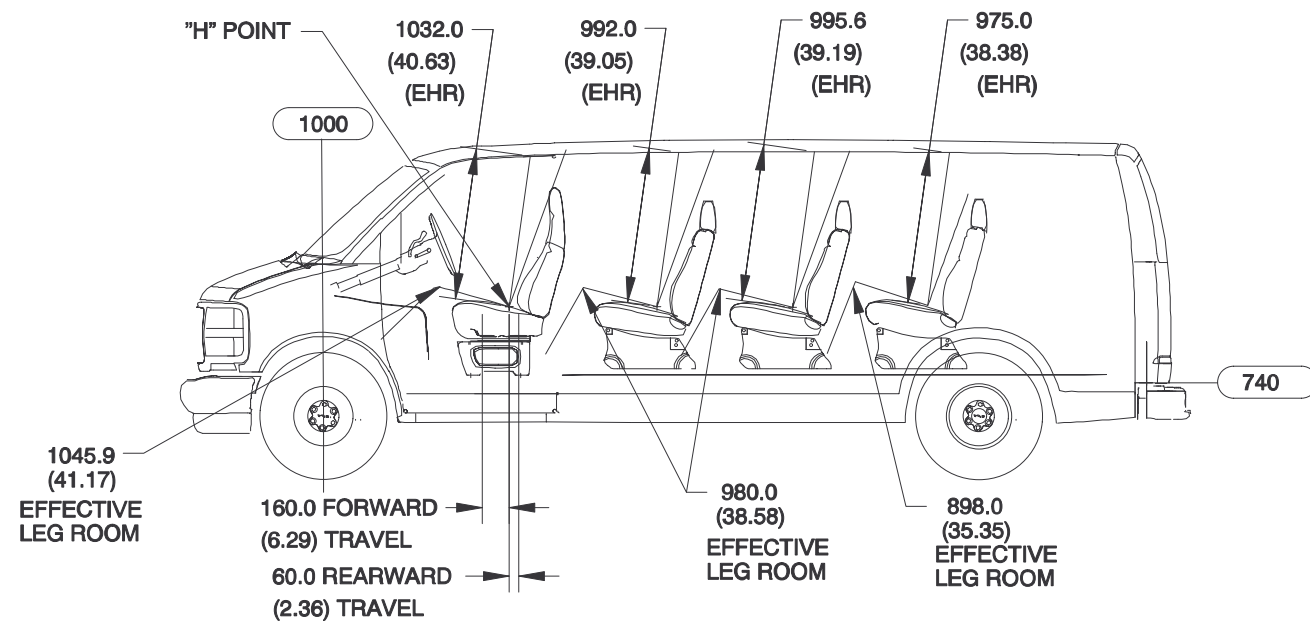

G (217/317)(05/06) 155" Wheelbase, Interior, 15 Passenger

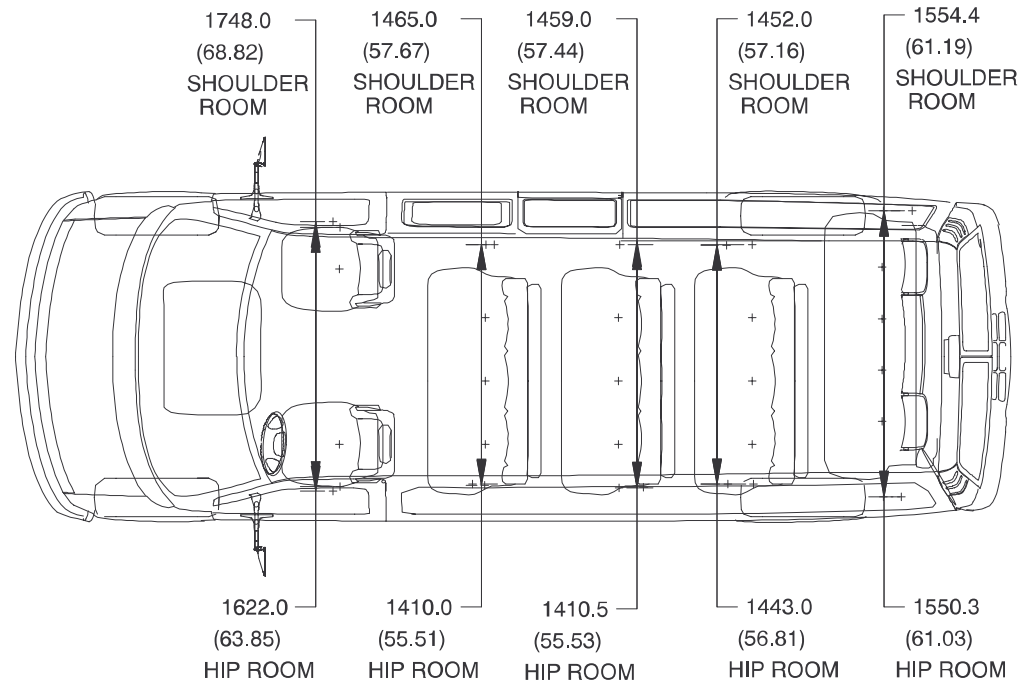

H-POINTS FOR 15 PASSENGER 155" W/B

	DRIVER		PASSENGER	
	L=2115.0		L=2115.0	
	H=1160.0		H=1160.0	
	W=-533.0		W=533.0	
SEAT ROW 1 (3 PASS BENCH)	L=3003	L=3003.0	L=3003.0	
	H=1153.5	H=1153.5	H=1153.5	
	W=-535.5	W=-148.5	W=238.5	
SEAT ROW 2 (3 PASS BENCH)	L=3816.0	L=3816.0	L=3816.0	
	H=1153.5	H=1153.5	H=1153.5	
	W=-535.5	W=-148.5	W=238.5	
SEAT ROW 3 (3 PASS BENCH)	L=4629.0	L=4629.0	L=4629.0	
	H=1153.5	H=1153.5	H=1153.5	
	W=-535.5	W=-148.5	W=238.5	
SEAT ROW 4 (4 PASS BENCH)	L=5420.5	L=5420.5	L=5420.5	L=5420.5
	H=1153.5	H=1153.5	H=1153.5	H=1153.5
	W=-395.0	W=-81.0	W=156.5	W=546.0

NOTE: CUTAWAY H-POINTS FOR DRIVER AND PASS SAME AS ABOVE.

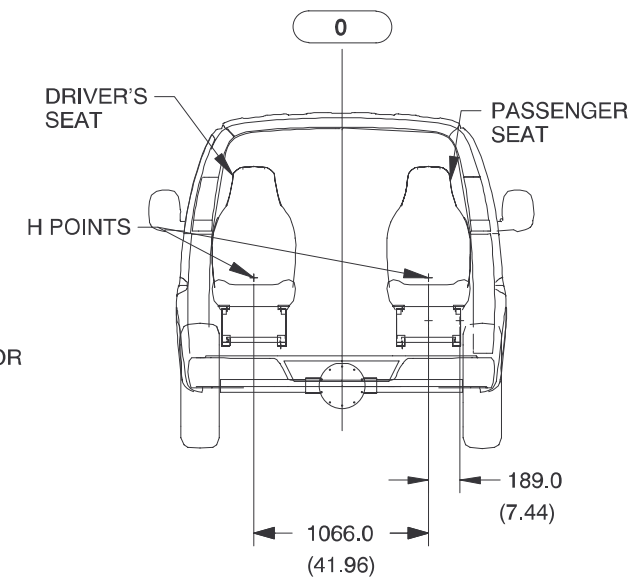
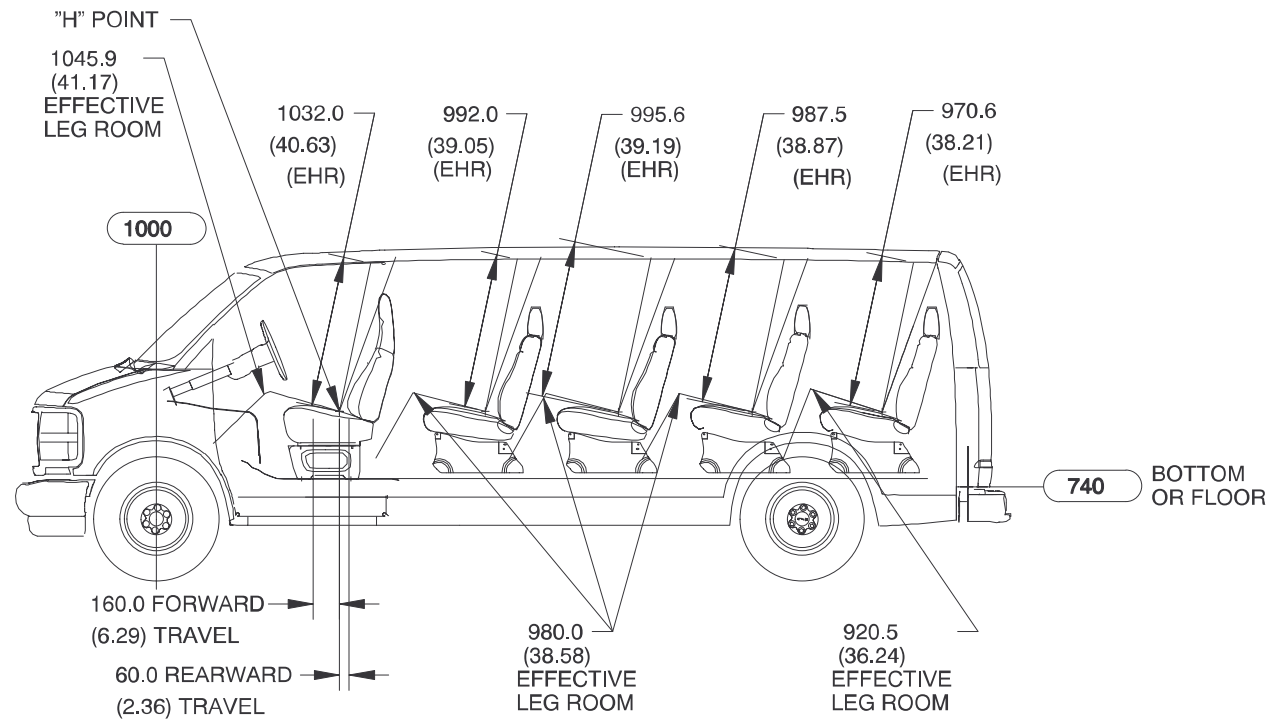

EHR = EFFECTIVE HEADROOM

G 00000 Seat Riser Assembly Mounting

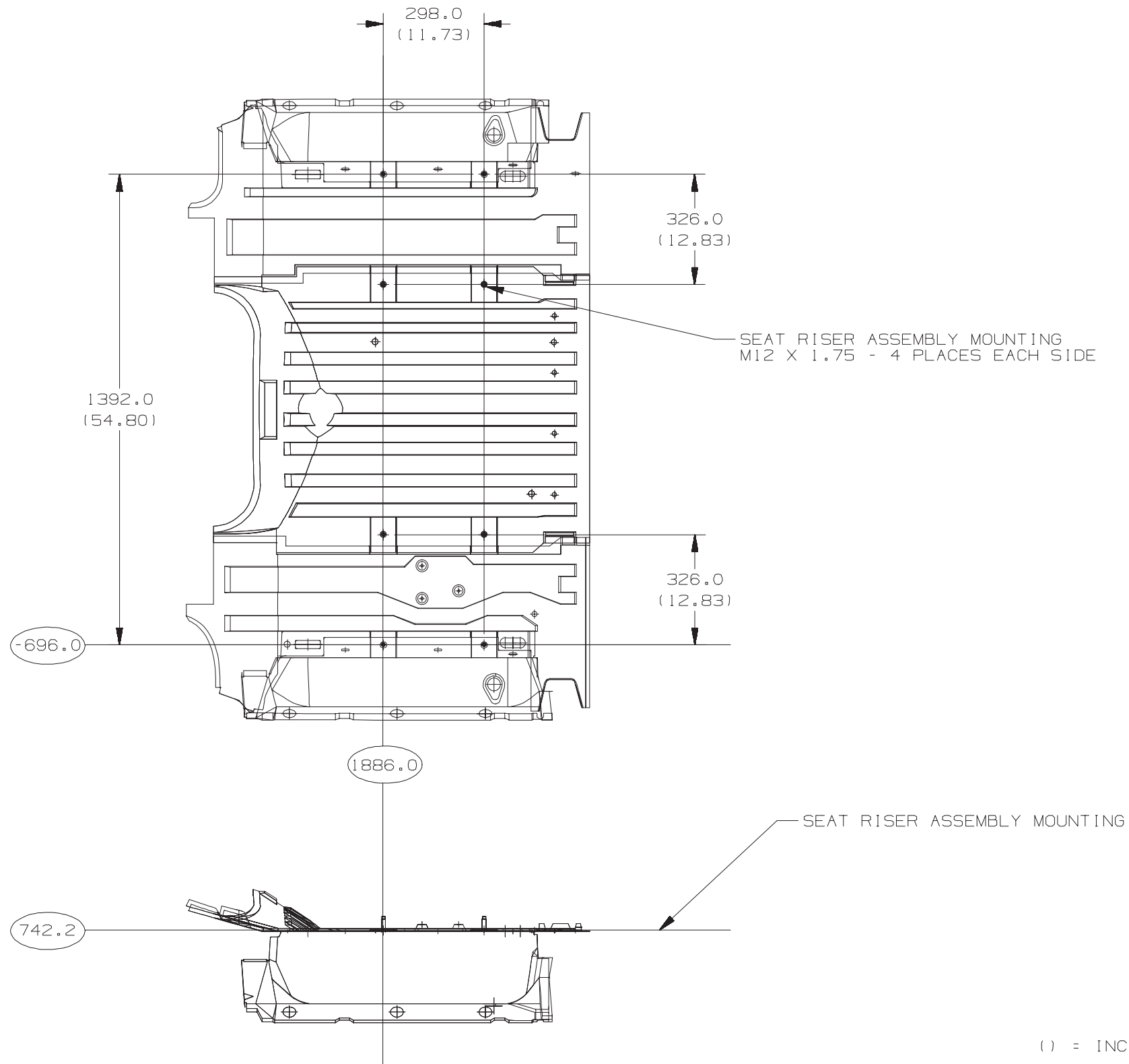

G (114/214/217/314/317)(05/06) Roof Bows, Pedal Positions and Steering Wheel

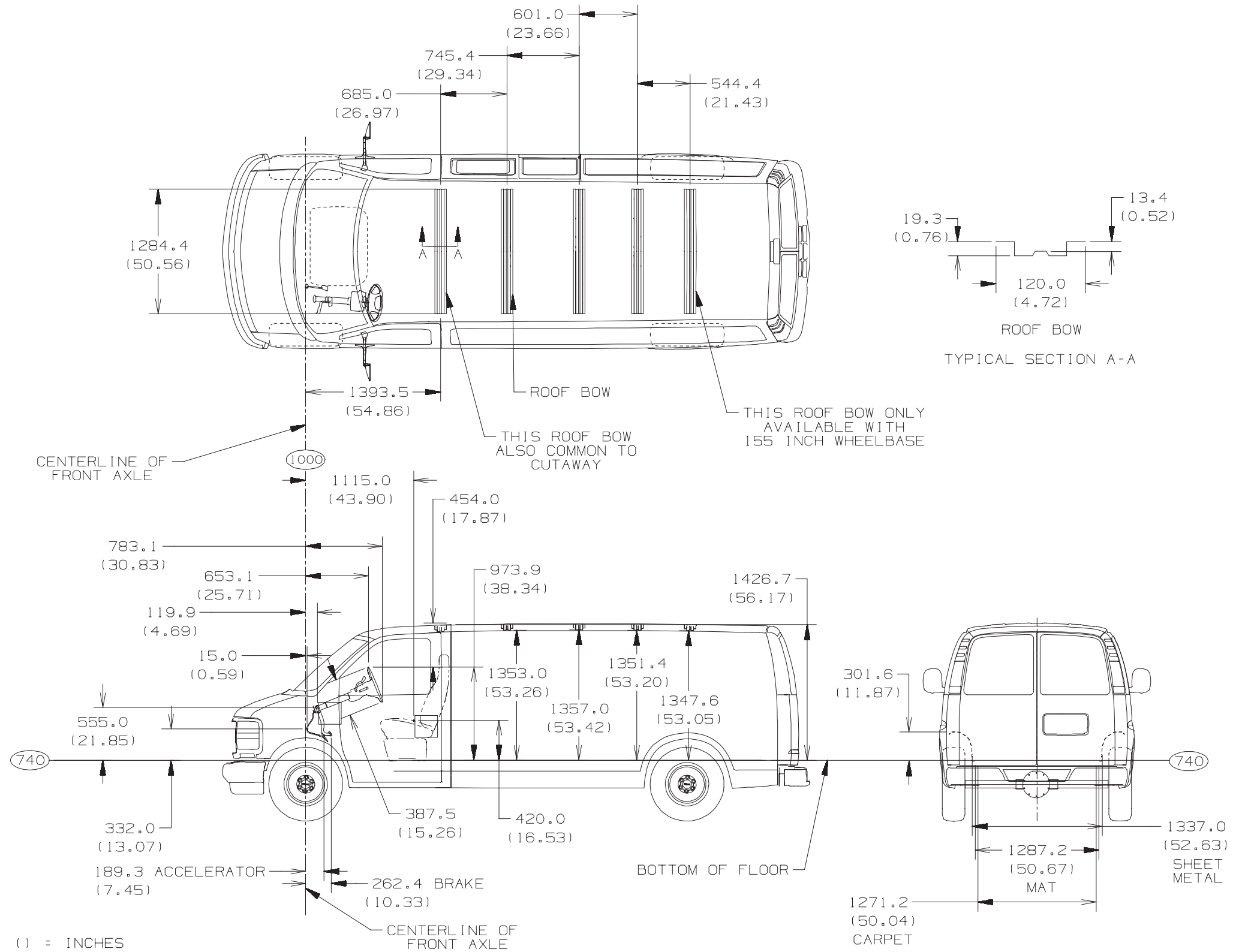

G (114/214/217/314/317)(05/06) Exterior, Glass

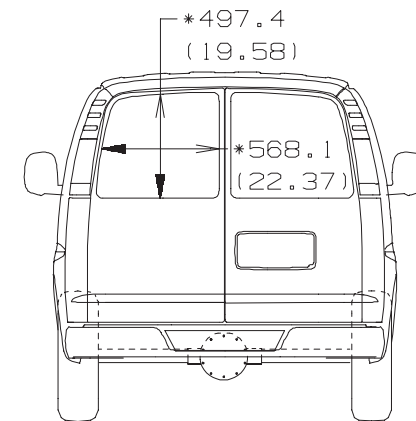
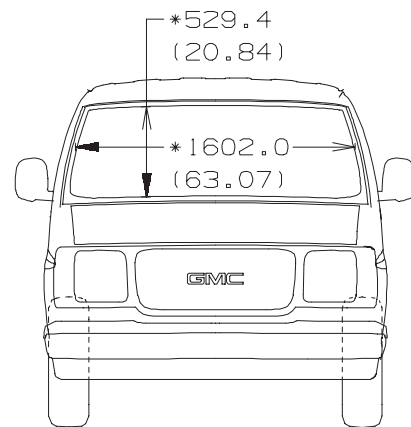
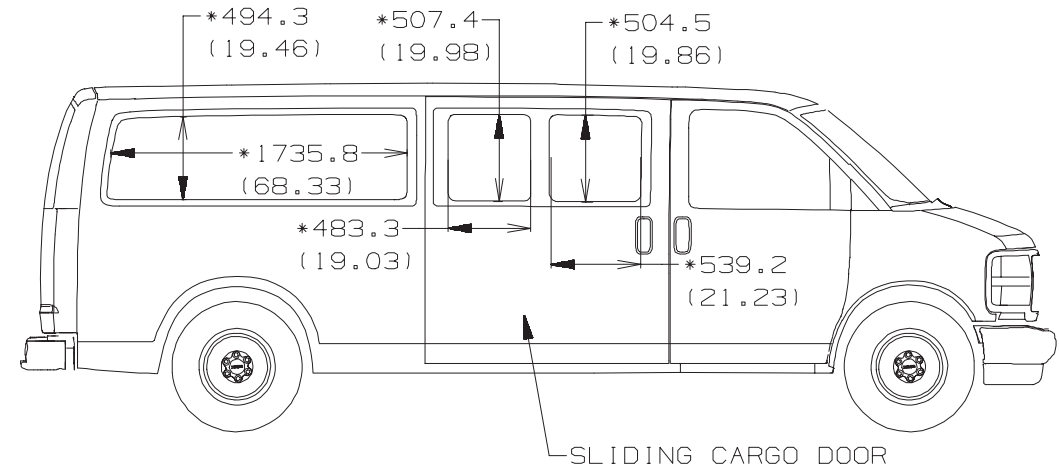
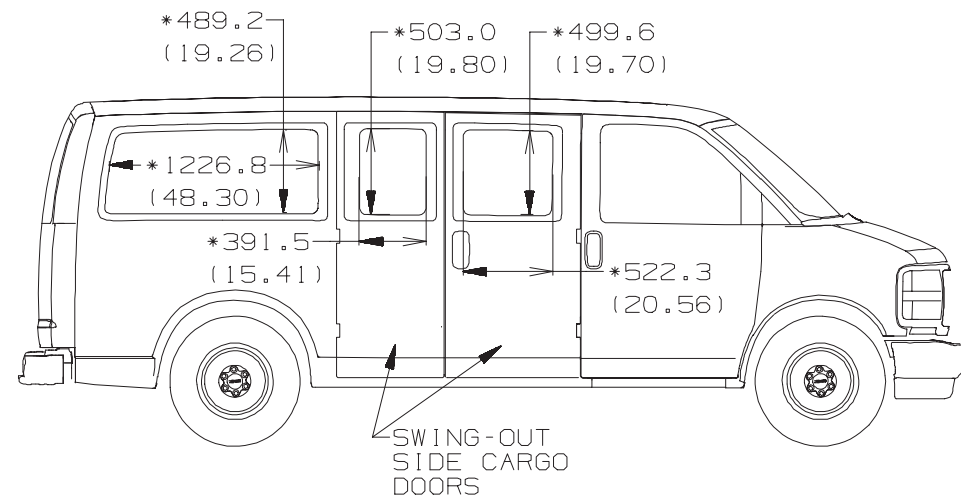
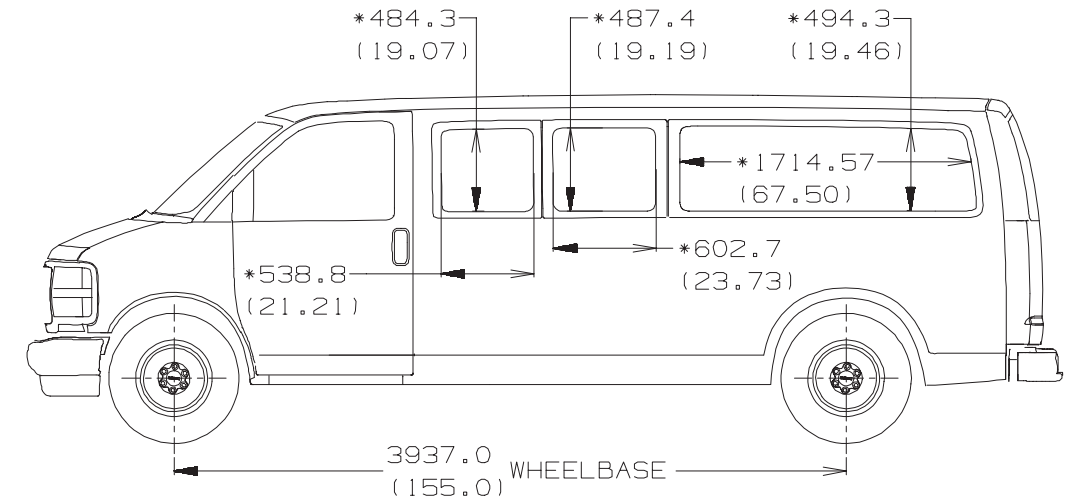
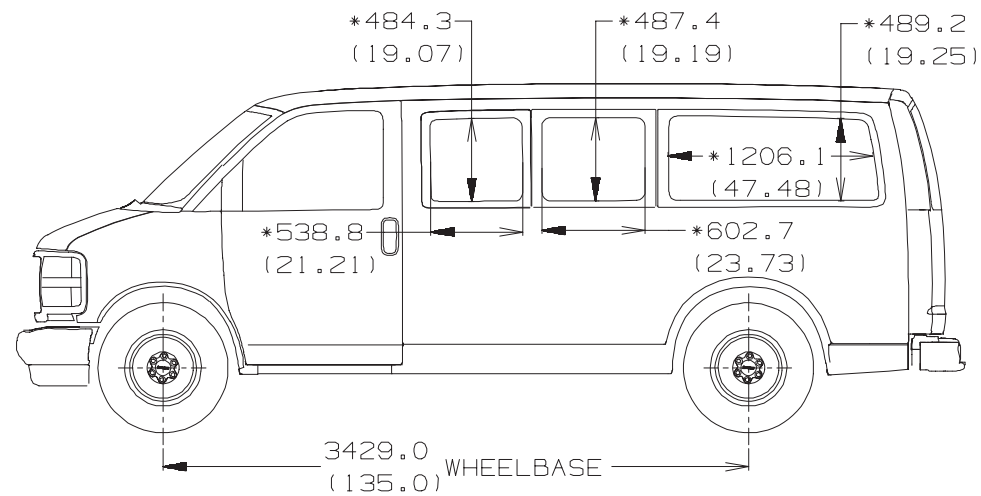

() = INCHES

* = DAYLIGHT OPENING

G (114/214/217/314/317)(05/06) Sign Area

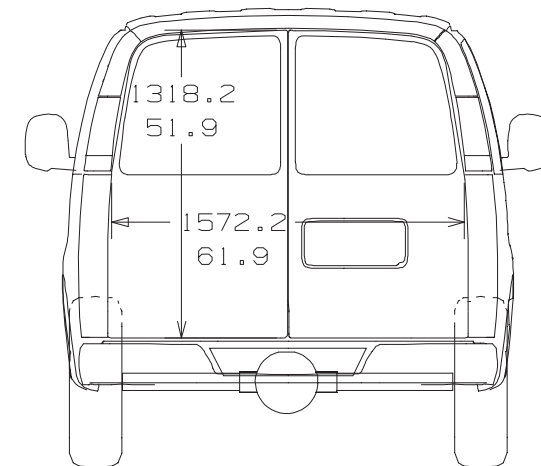
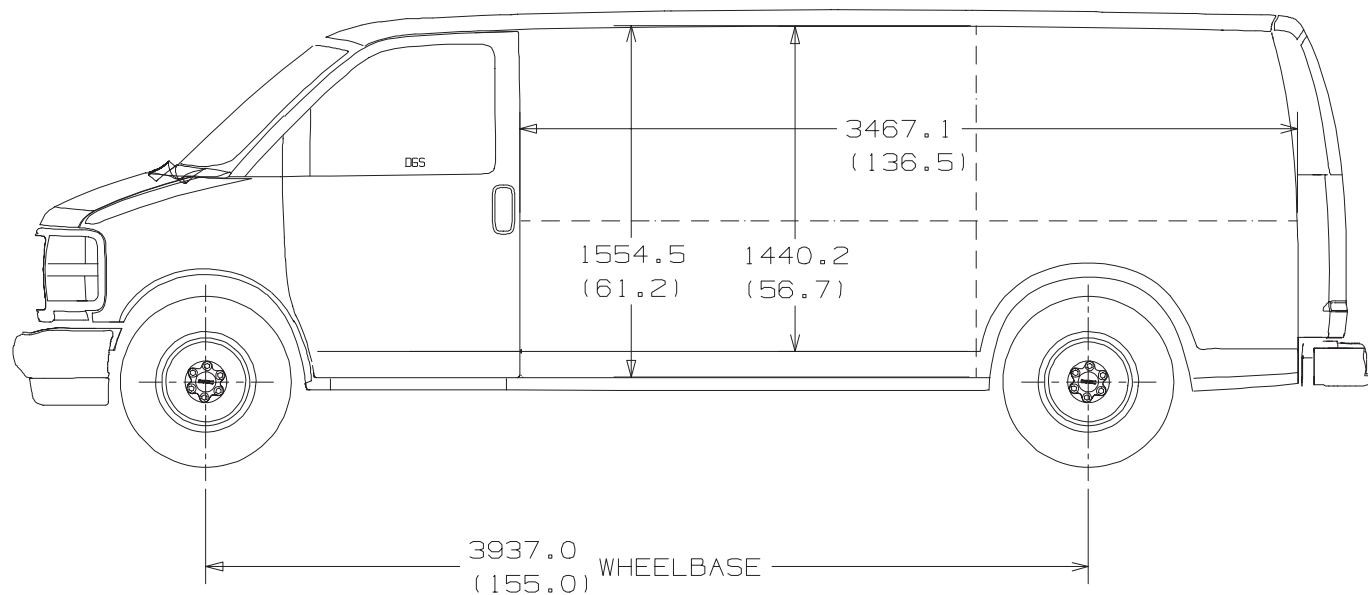
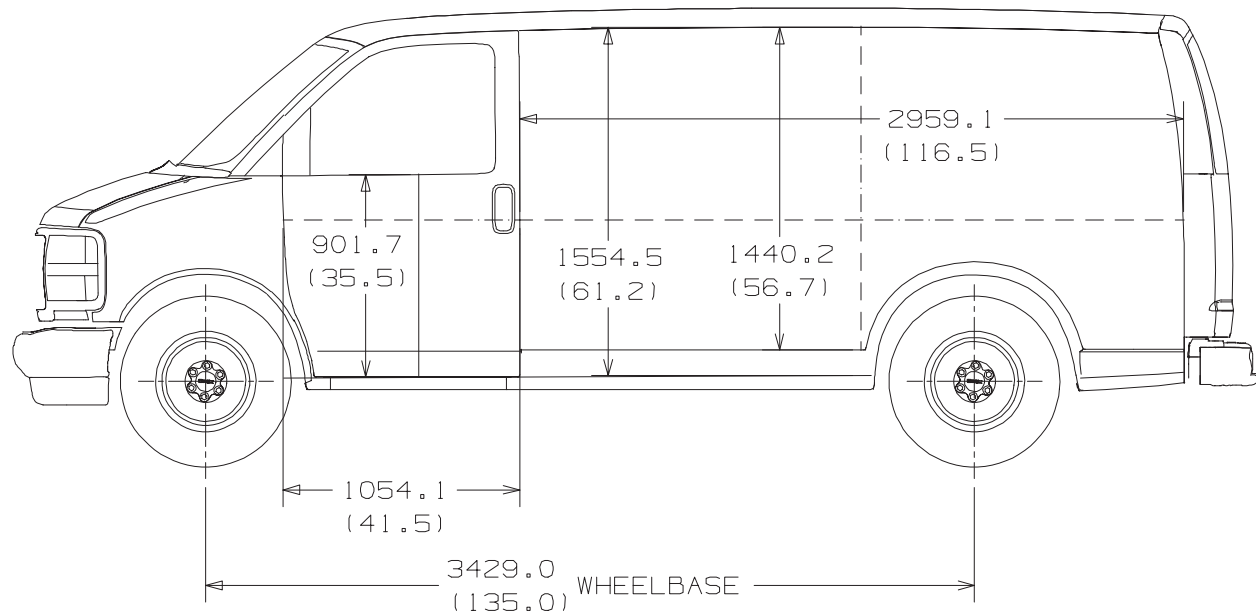

() = INCHES

G (315/318/319)(03/32) Cutaway, Exterior

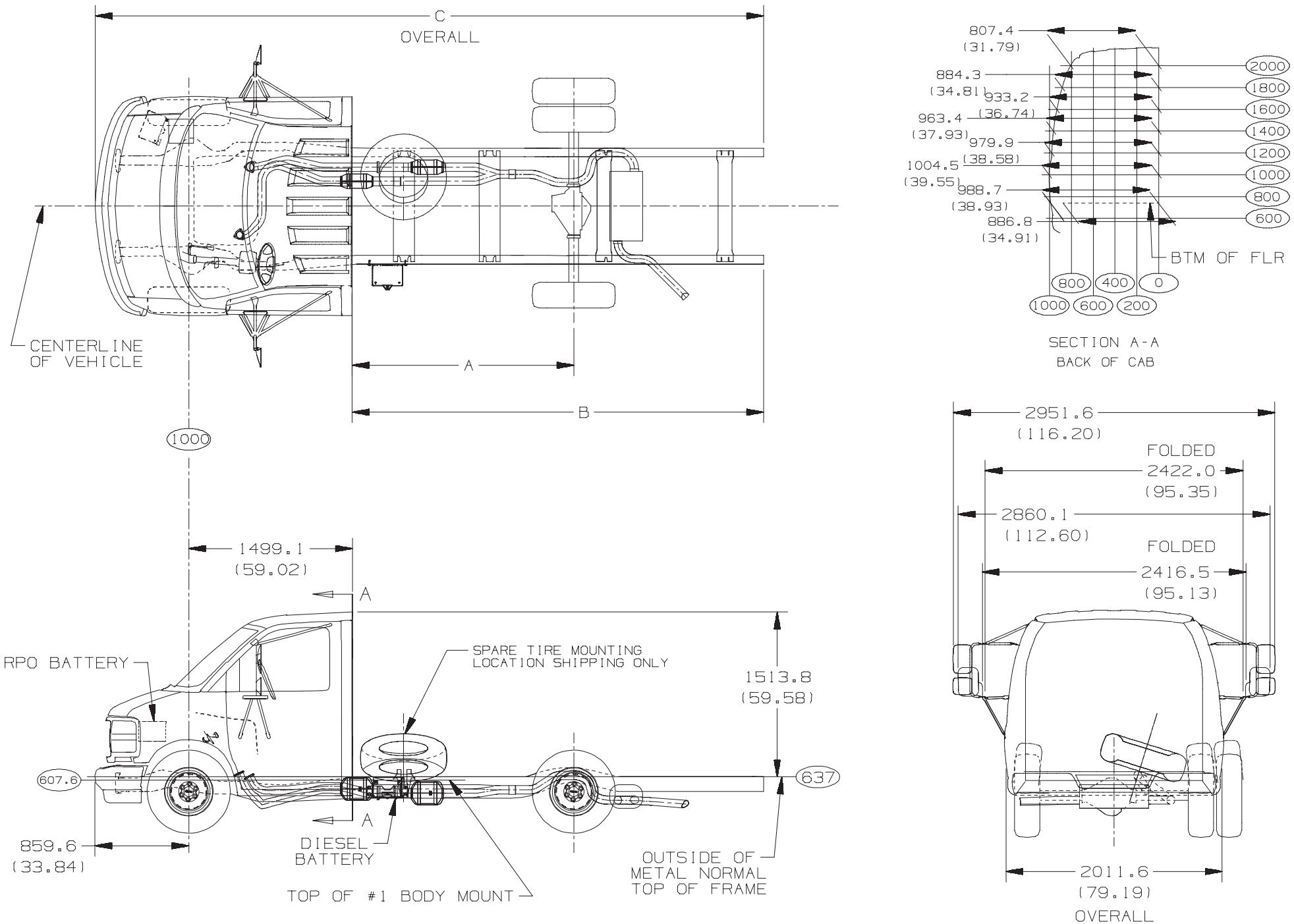

	139"	159"	177"		139"	159"	177"		139"	159"	177"
A	2031.8 (80.00)	2539.8 (100.00)	2997.0 (118.00)	B	3770.8 (148.45)	4278.8 (168.45)	4736.0 (186.45)	C	6129.8 (241.33)	6637.8 (261.33)	7095.0 (279.33)

() = INCHES

G (315/318/319)(03/32) Cutaway, Interior

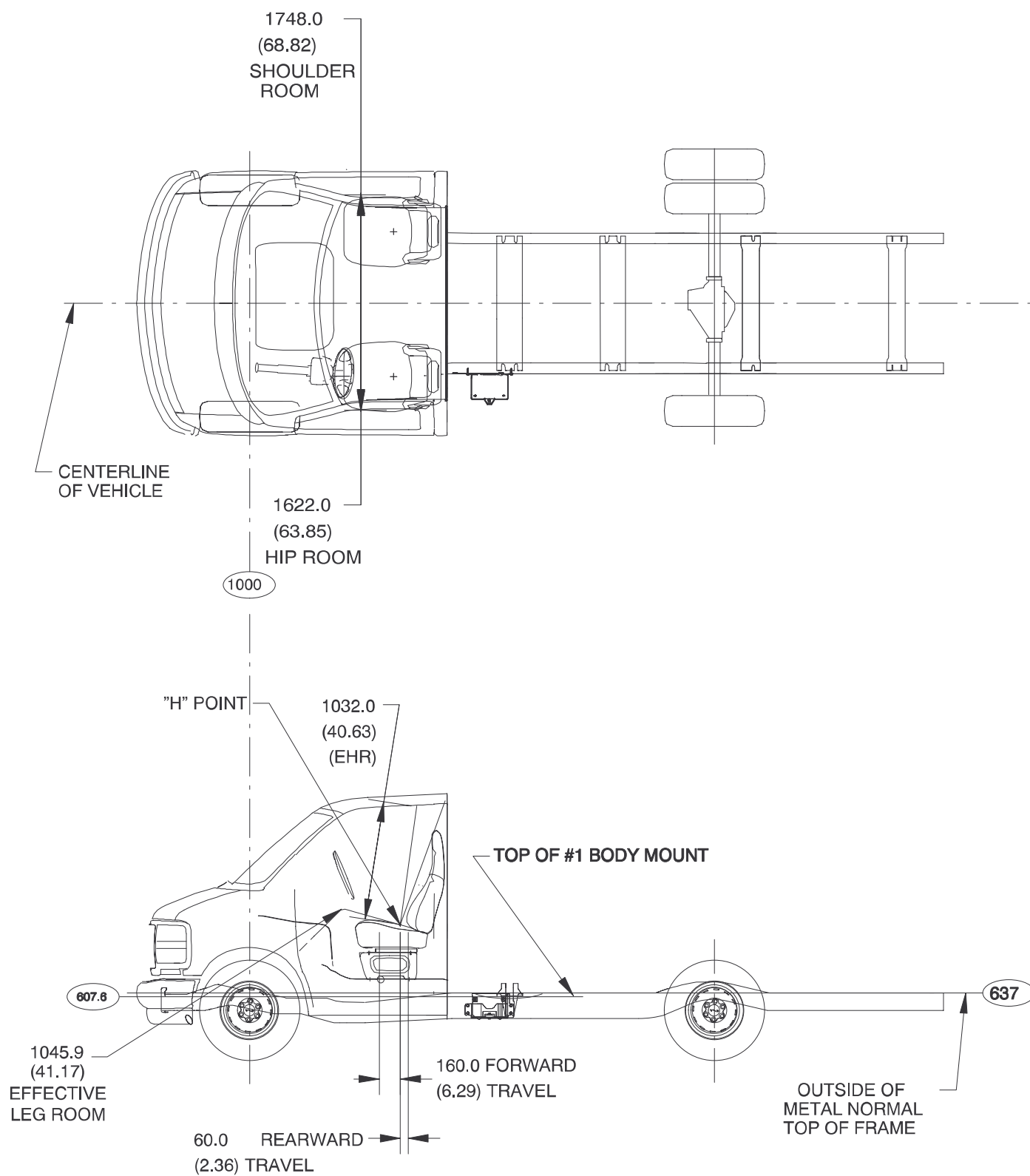

H-POINTS FOR CUTAWAYS

PASSENGER	
L=	2115.0
H=	1160.0
W=	533.0
DRIVER	
L=	2115.0
H=	1160.0
W=	-533.0

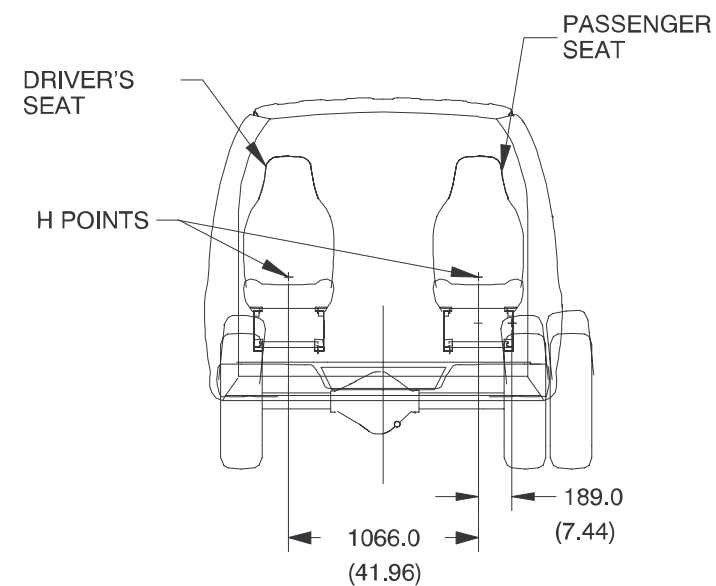

Cutaway, Rear Flange

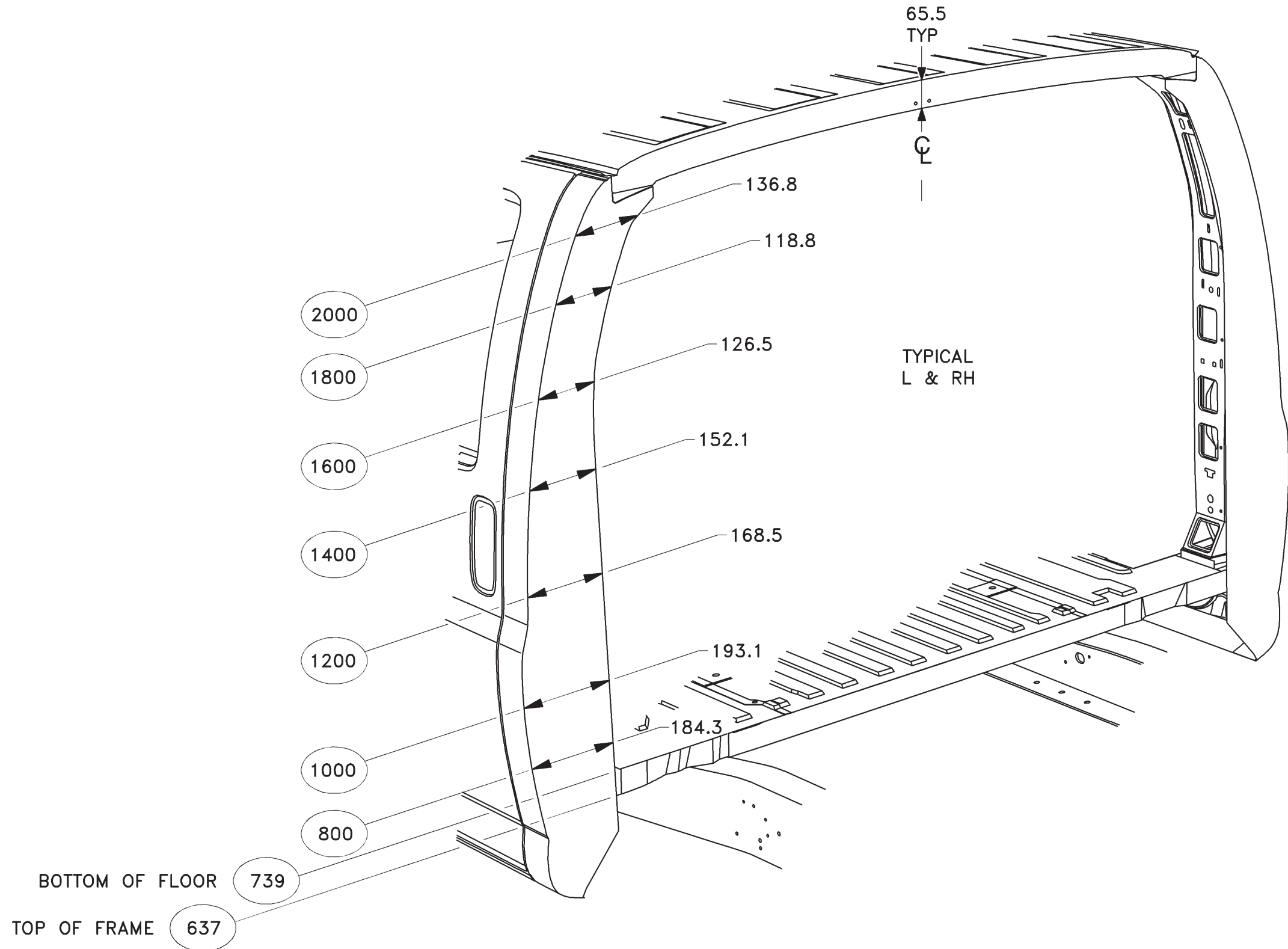

G (114/214)(05/06) Light Duty Crossmember Arrangement, 135" Wheelbase

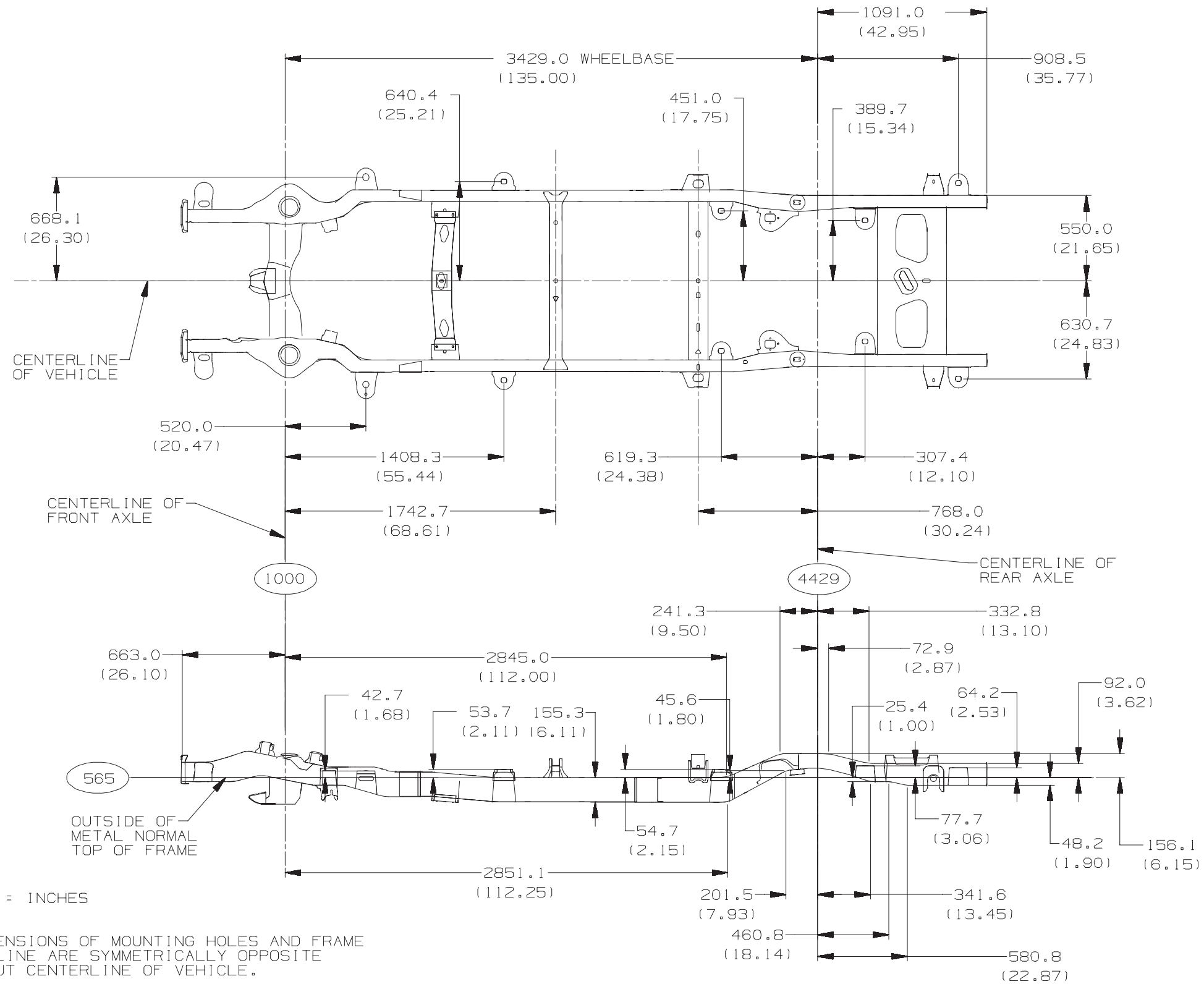

G (214/314)(05/06) Heavy Duty Crossmember Arrangement, 135" Wheelbase

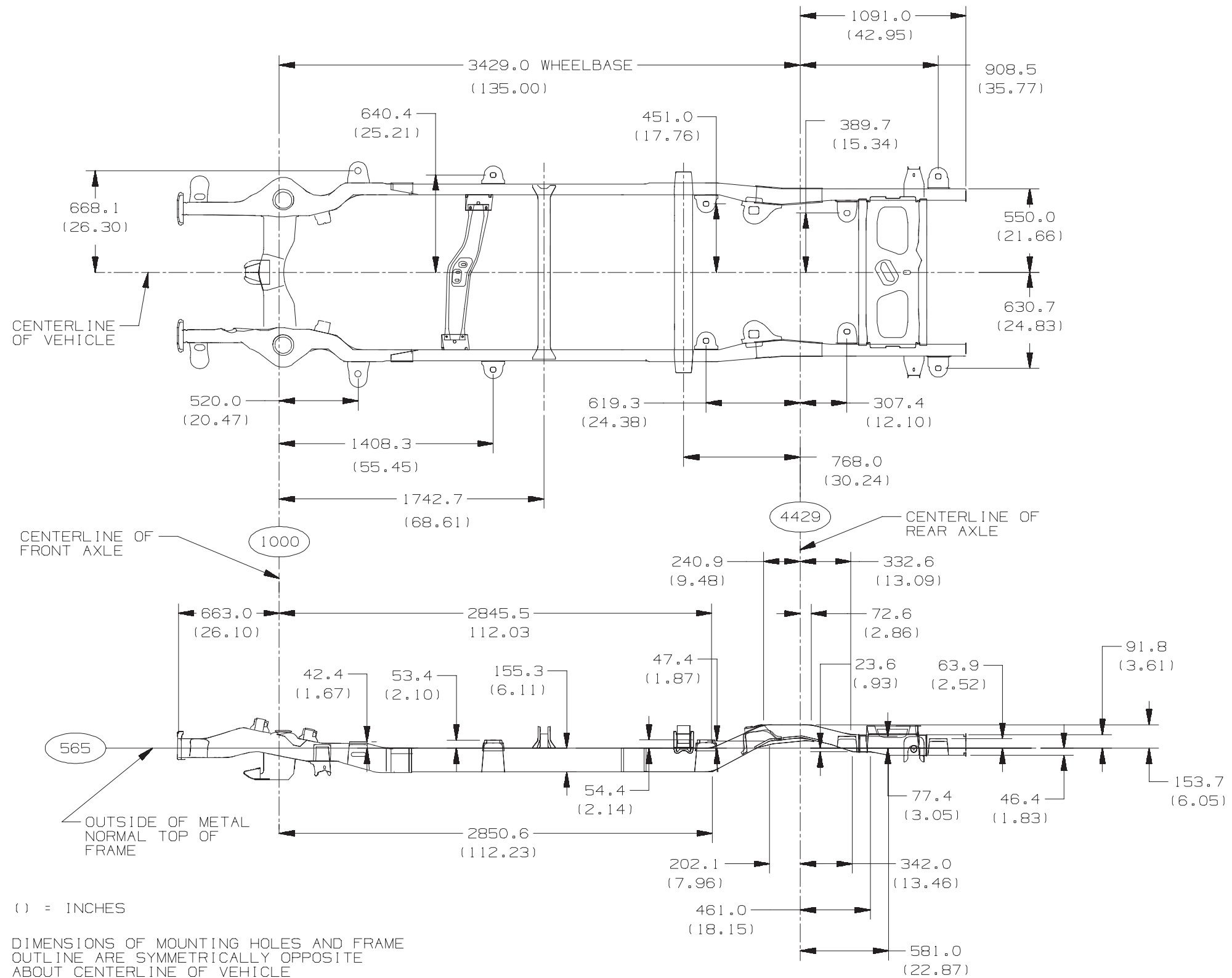

G 217(05/06) Light Duty Crossmember Assembly, 155" Wheelbase

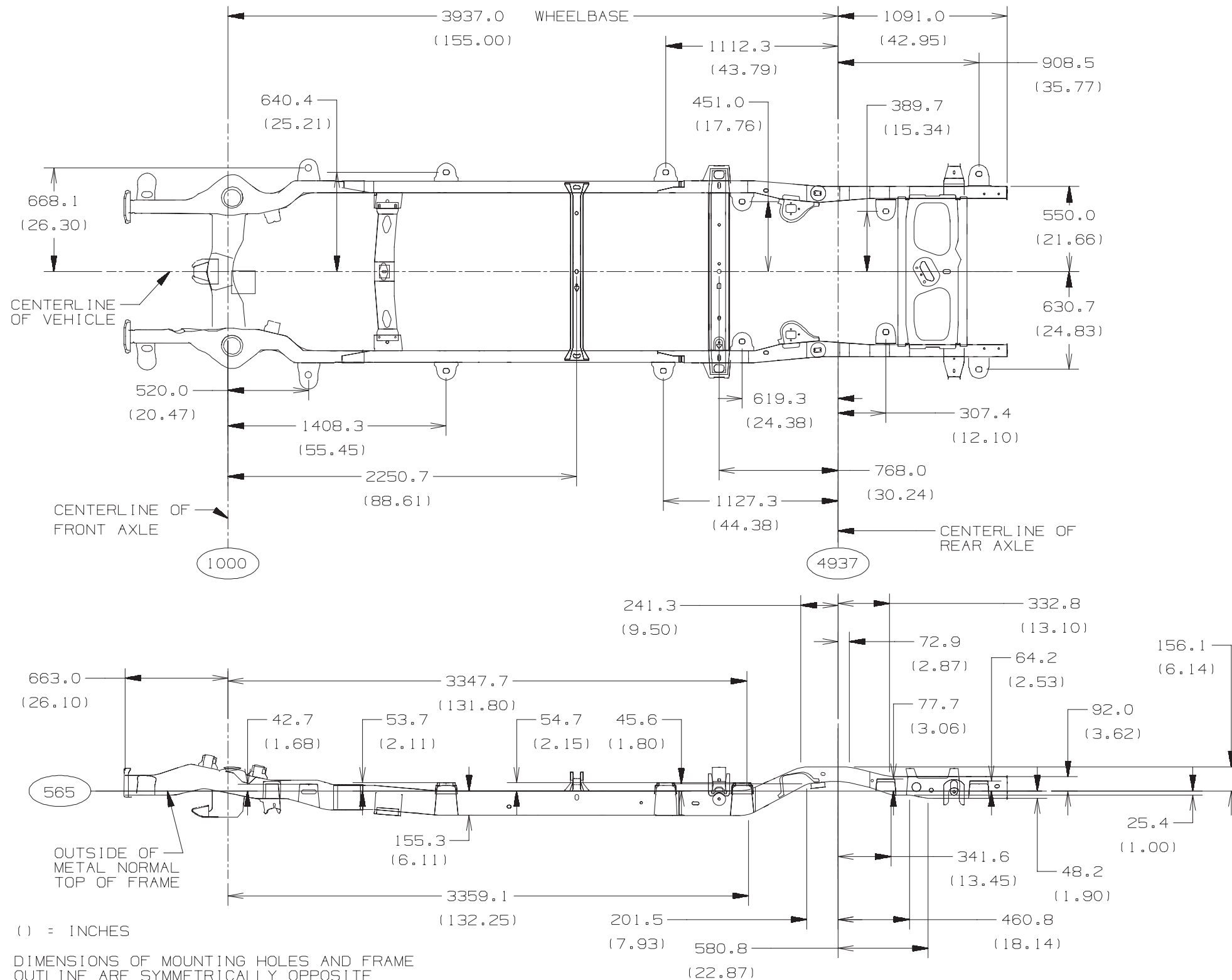

G (217/317)(05/06) Heavy Duty Crossmember Arrangement, 155" Wheelbase

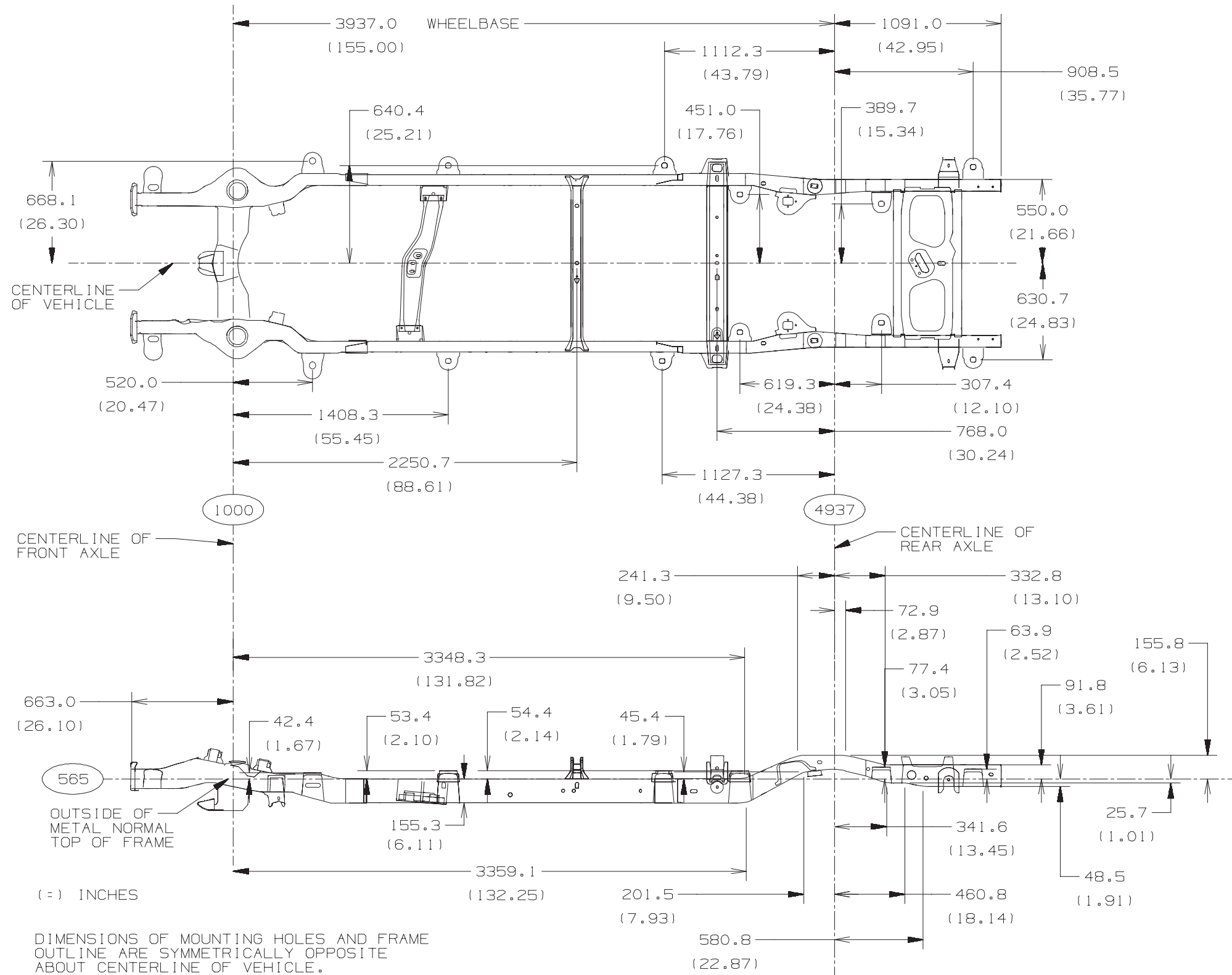

G 315(03/32) Heavy Duty Cutaway Crossmember Arrangement, 139" Wheelbase

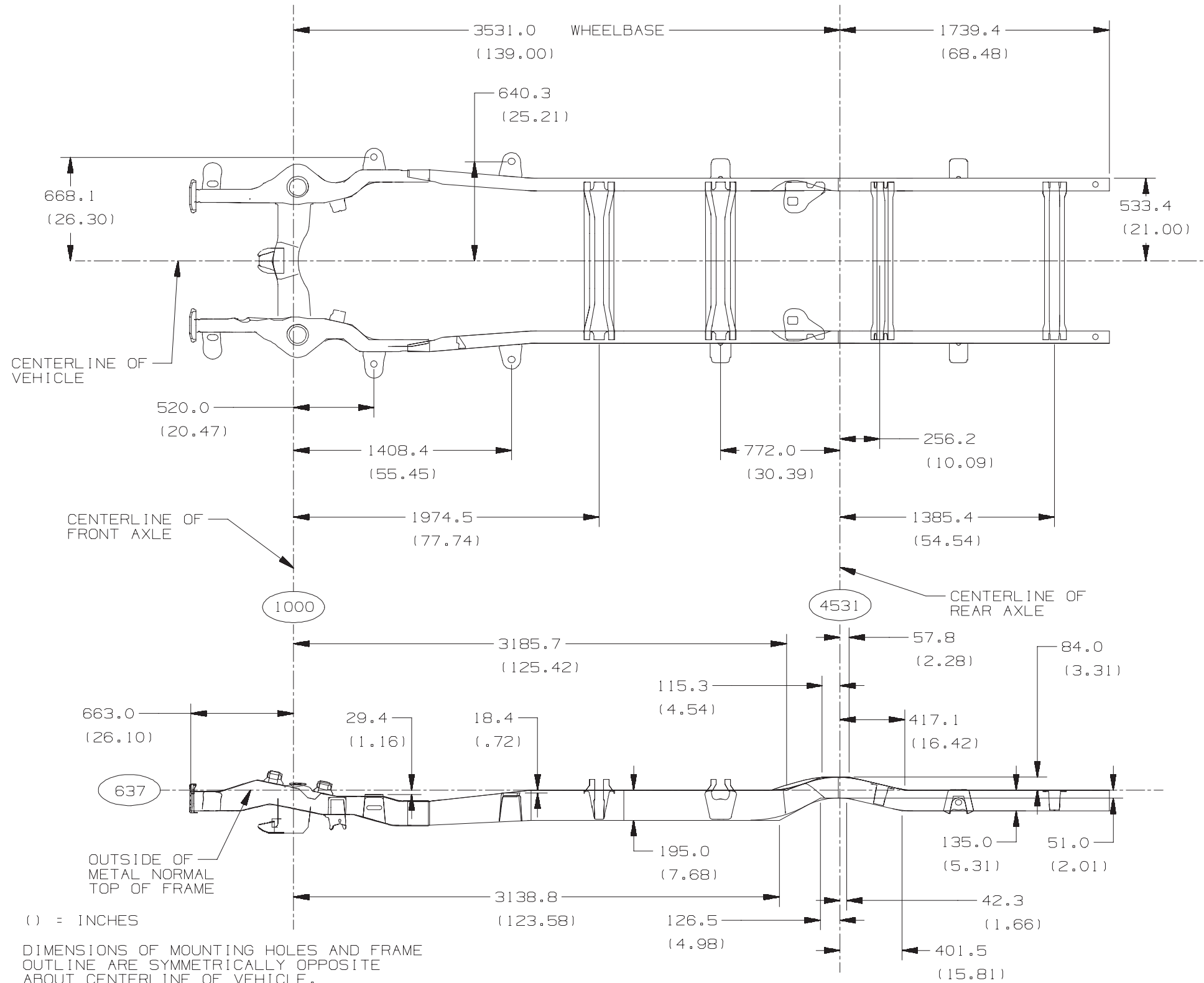

G 318(03/32) Heavy Duty Cutaway Crossmember Arrangement, 159" Wheelbase

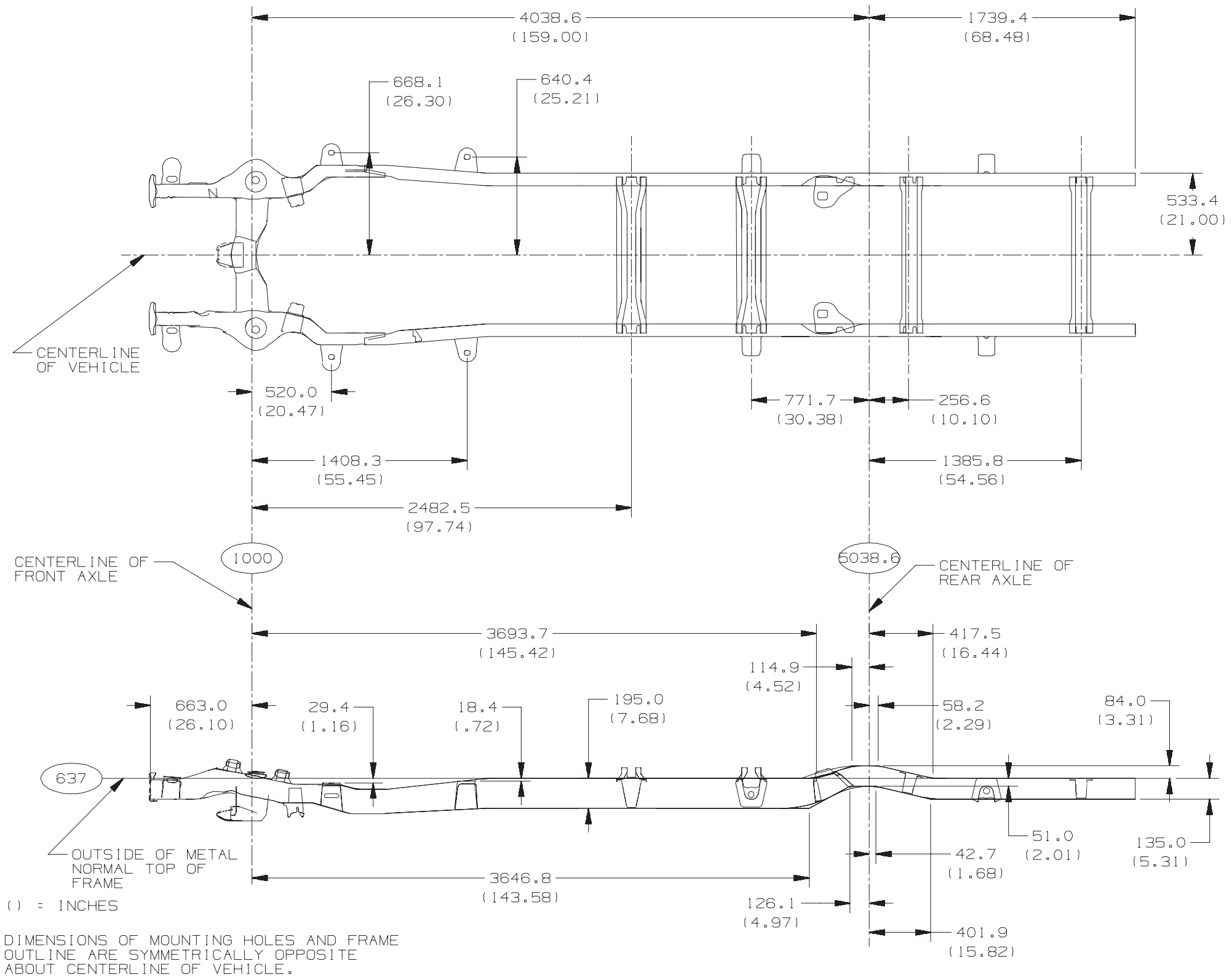

G 319(03/32) Heavy Duty Cutaway Crossmember Arrangement, 177" Wheelbase

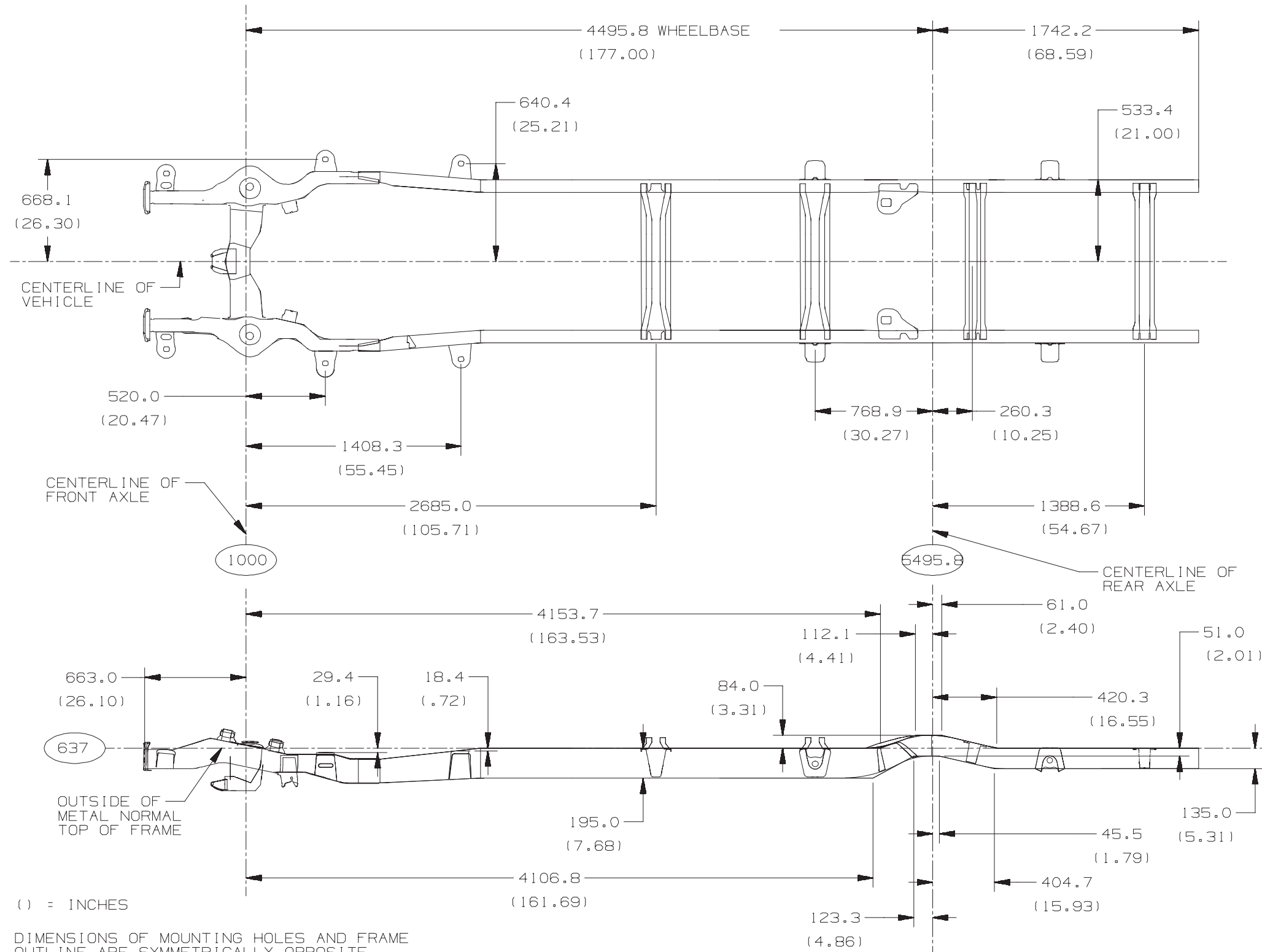

() = INCHES

DIMENSIONS OF MOUNTING HOLES AND FRAME OUTLINE ARE SYMMETRICALLY OPPOSITE ABOUT CENTERLINE OF VEHICLE.

G (114/214/217/314/317)(05/06) Spare Tire Carrier

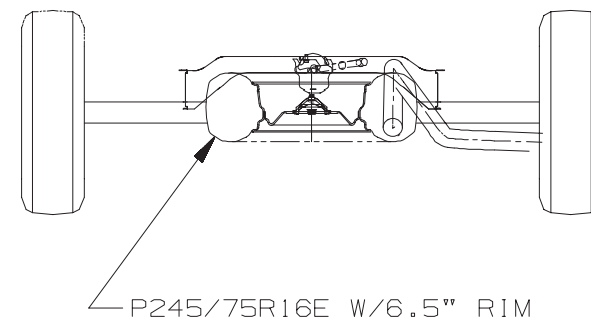
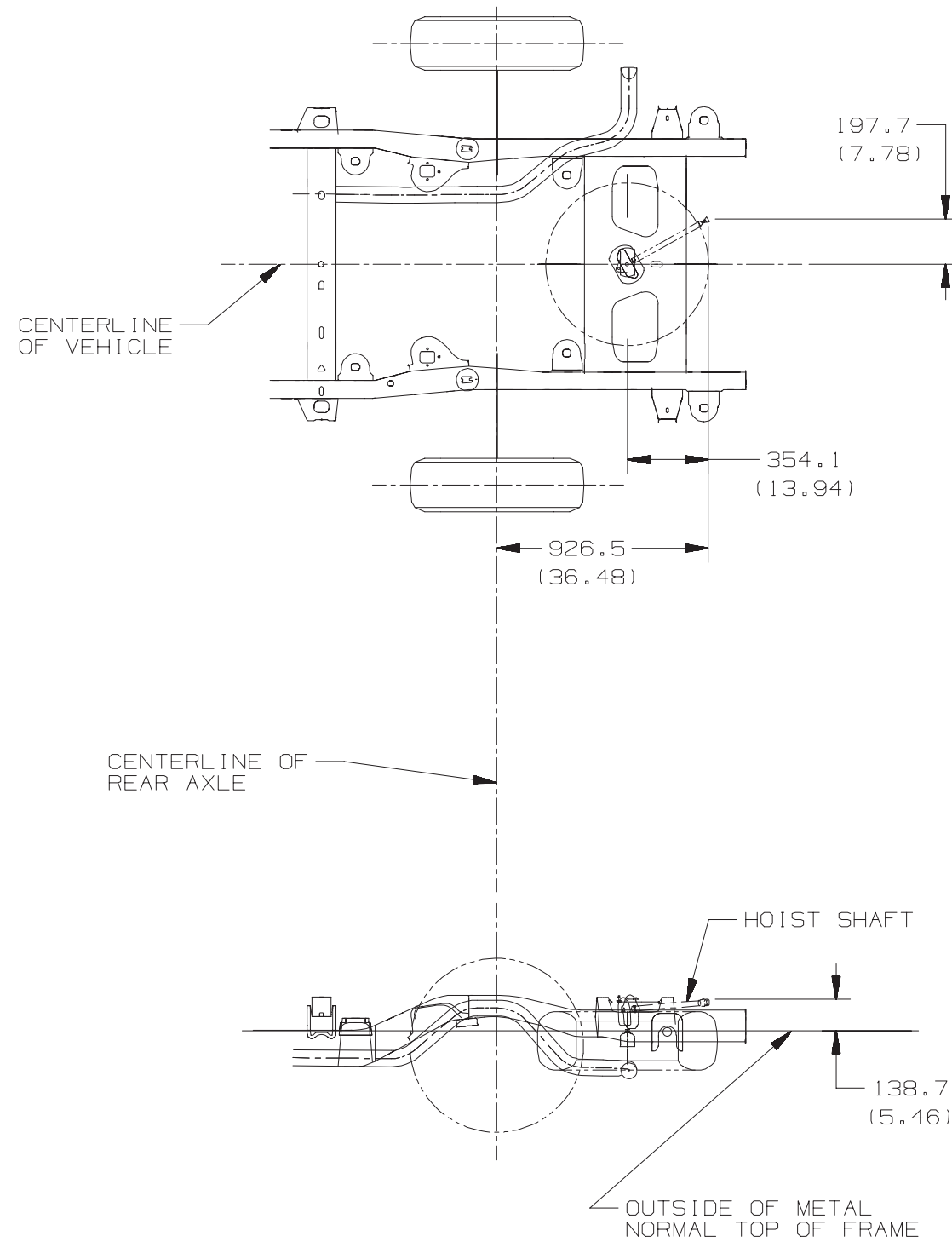

() = INCHES

G (114/214/217/314/317)(05/06) Trailer Hitch, 135"/155" Wheelbase

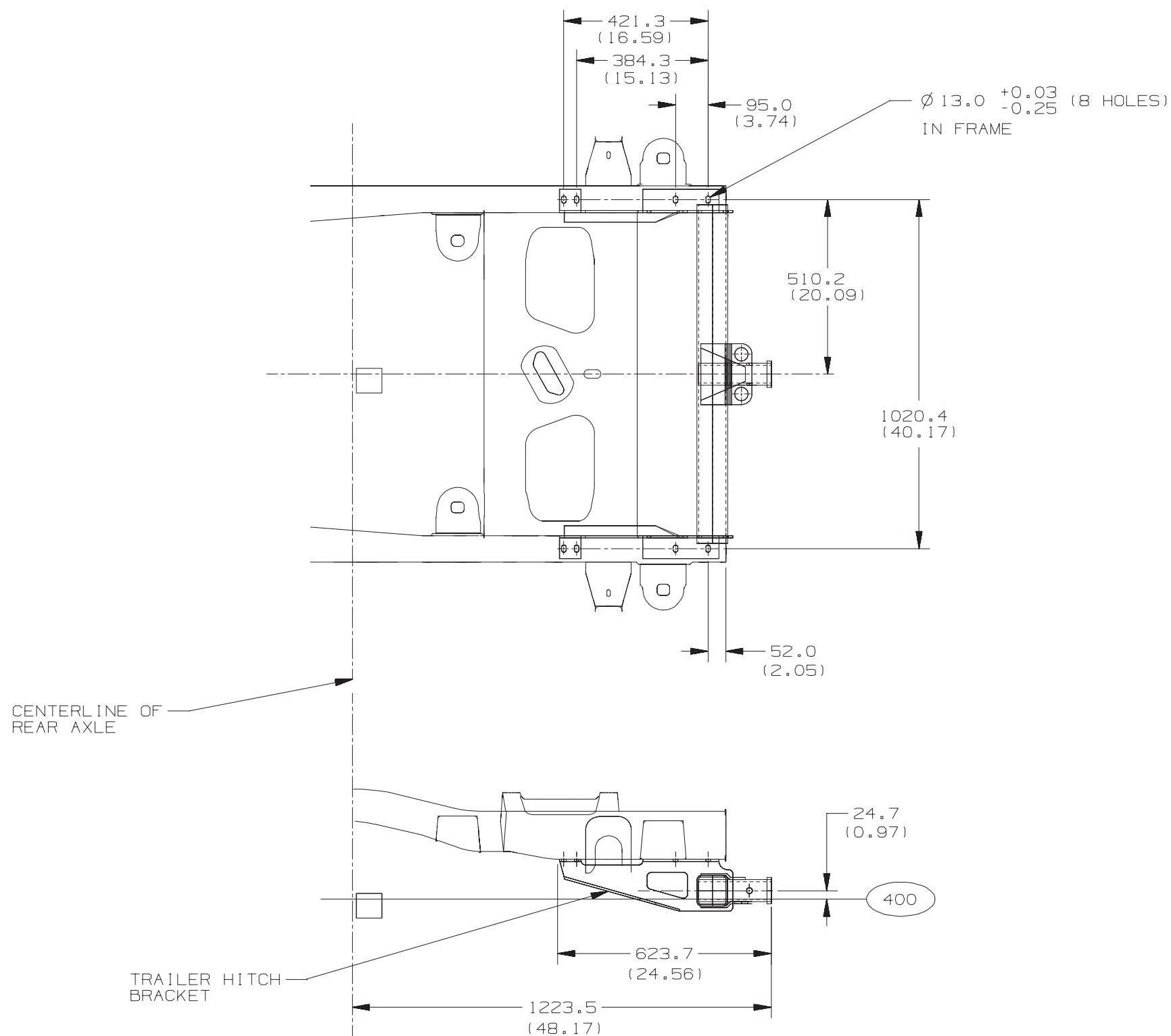

() = INCHES

G (114/214/217/314/317)(05/06) Front Axle/Tire Data Chart

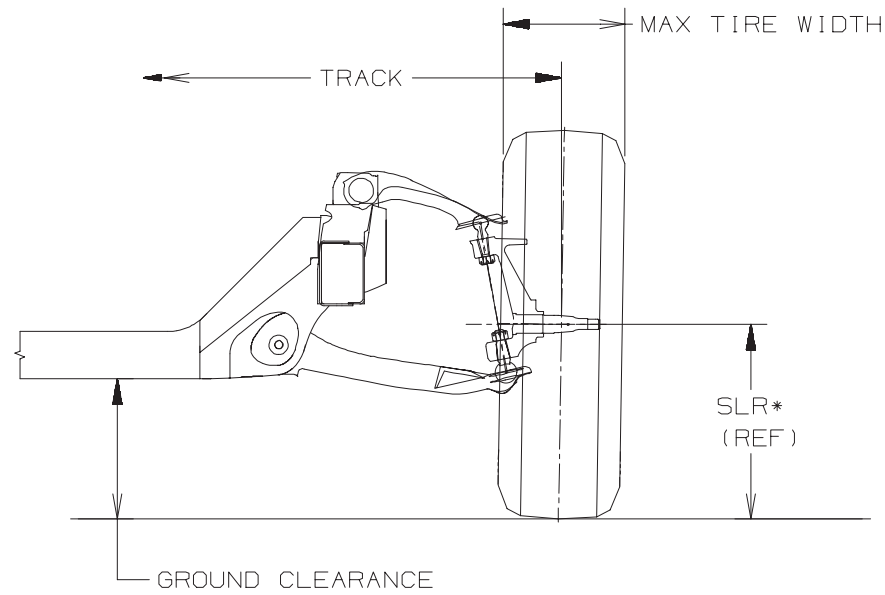

* MINIMUM GROUND CLEARANCE TO BE CALCULATED BY USING GROSS AXLE HEIGHT AND RECOMMENDED TIRE PRESSURE

SERIES	TIRE	SLR	GVW RANGE	TRACK	WHEEL OFFSET	GROUND CLEARANCE	MAX TIRE WIDTH
G11405	P215 75R15	313.9	6100	1721.2	0.0	177.2	226.0
	P235 75R15XLS	325.9	7100	1721.2	0.0	189.2	240.0
G11406	P235 75R15XLS	325.9	7100	1721.2	0.0	189.2	240.0
G21405	LT225 75R16D	344.9	7300	1695.2	+13.0	208.2	228.0
	LT225 75R16E	345.9	8600	1721.2	+17.0	209.2	228.0
G21406	LT225 75R16E	345.9	8600	1721.2	+17.0	209.2	228.0
G21705	LT225 75R16D	344.9	7300	1695.2	+13.0	208.2	228.0
	LT225 75R16E	345.9	8600	1721.2	+17.0	209.2	228.0
G21706	LT225 75R16D	344.9	8600	1721.2	+17.0	208.2	228.0
G31405	LT245 75R16E	357.9	9500	1721.2	+17.0	221.2	248.0
G31406	LT245 75R16E	357.9	9500	1721.2	+17.0	221.2	248.0
G31705	LT245 75R16E	357.9	9500	1721.2	+17.0	221.2	248.0
G31706	LT245 75R16E	357.9	9500	1721.2	+17.0	221.2	248.0

G (114/214/217/314/317)(05/06) Rear Axle/Tire Data Chart

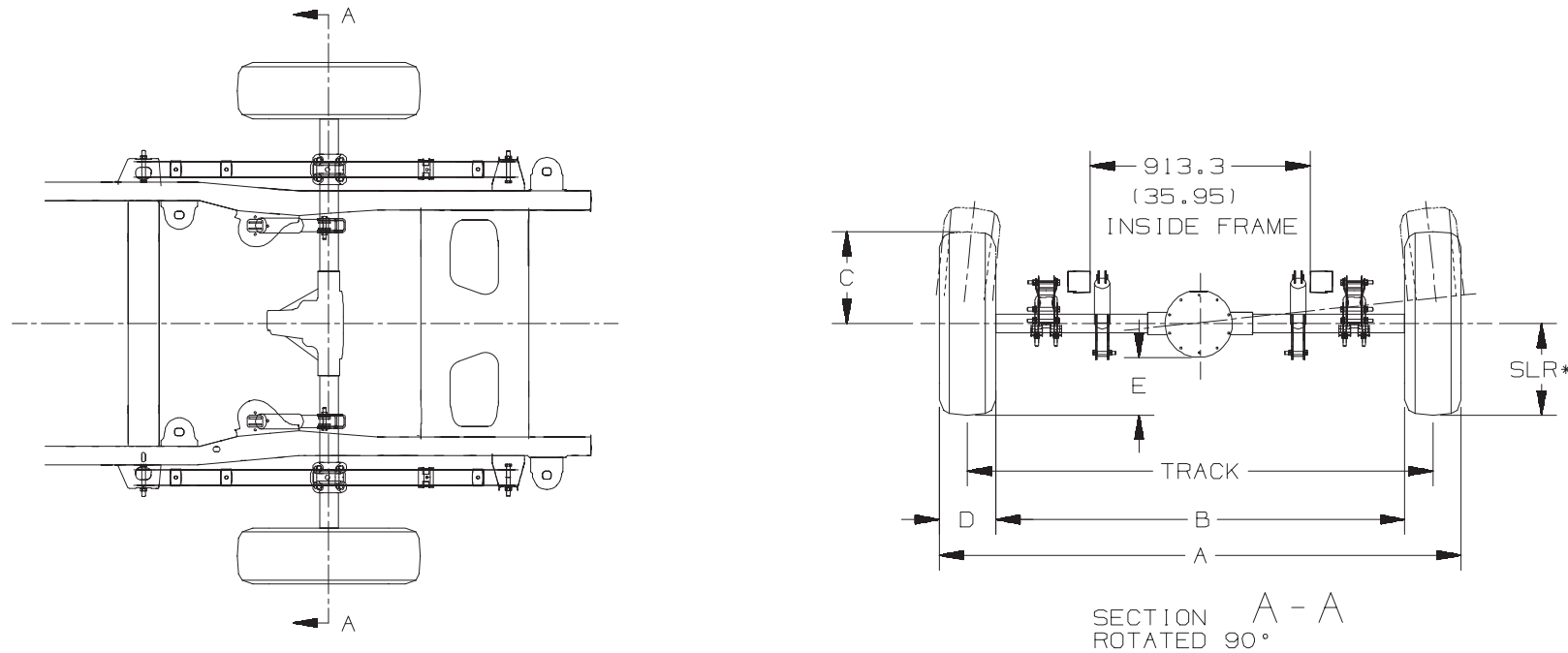

() = INCHES

* MINIMUM GROUND CLEARANCE TO BE CALCULATED BY USING GROSS AXLE HEIGHT AND RECOMMENDED TIRE PRESSURE

SERIES	TIRE	SLR	REAR WHEEL	GVW	TRACK	WHEEL OFFSET	DIM A	DIM B	DIM C	DIM D	DIM E
G11405	P215 75R15	313.9	SINGLE	6100	1718.0	0.0	1944.0	1492.0	356.5	166.1	172.1
	P235 75R15XLS	325.9	SINGLE	7100	1718.0	0.0	1958.0	1478.0	372.5	240.0	184.1
G11406	P235 75R15XLS	325.9	SINGLE	7100	1718.0	0.0	1958.0	1478.0	372.5	240.0	184.1
G21405	LT225 75R16D	344.9	SINGLE	7300	1700.0	+13.0	1928.0	1472.0	381.0	228.0	203.1
	LT225 75R16E	345.9	SINGLE	8600	1708.0	+17.0	1936.0	1480.0	381.0	228.0	204.1
G21406	LT225 75R16E	345.9	SINGLE	8600	1708.0	+17.0	1936.0	1480.0	381.0	228.0	204.1
G21705	LT225 75R16D	344.9	SINGLE	7300	1700.0	+13.0	1928.0	1472.0	381.0	228.0	203.1
	LT225 75R16E	345.9	SINGLE	8600	1708.0	+17.0	1936.0	1480.0	381.0	228.0	204.1
G21706	LT225 75R16D	344.9	SINGLE	8600	1708.0	+17.0	1936.0	1480.0	381.0	228.0	203.1
G31405	LT245 75R16E	357.9	SINGLE	9500	1708.0	+17.0	1951.0	1465.0	394.0	243.0	216.1
G31406	LT245 75R16E	357.9	SINGLE	9500	1708.0	+17.0	1951.0	1465.0	394.0	243.0	216.1
G31705	LT245 75R16E	357.9	SINGLE	9500	1708.0	+17.0	1951.0	1465.0	394.0	243.0	216.1
G31706	LT245 75R16E	357.9	SINGLE	9500	1708.0	+17.0	1951.0	1465.0	394.0	243.0	216.1

G (315/318/319)(03/32) Front Axle/Tire Data Chart

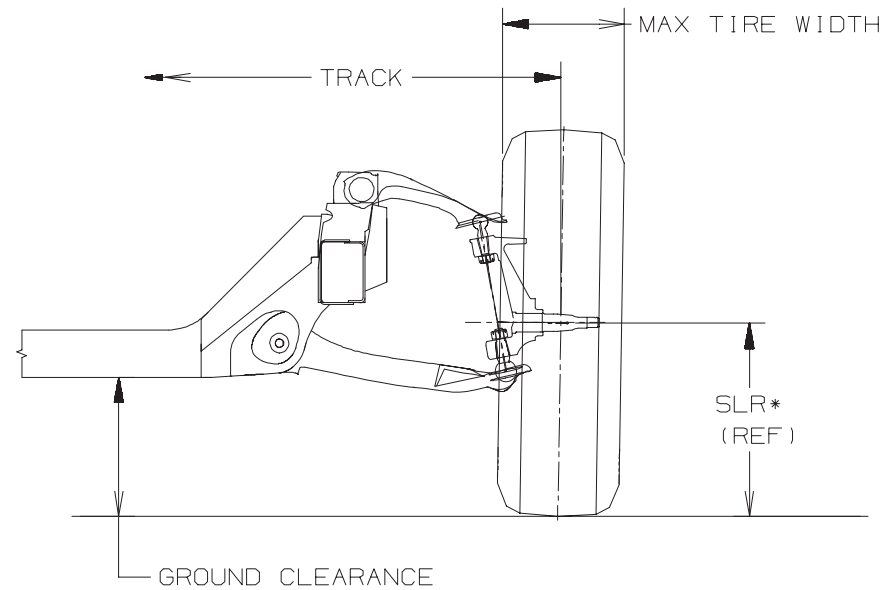

* MINIMUM GROUND CLEARANCE TO BE CALCULATED BY USING GROSS AXLE HEIGHT AND RECOMMENDED TIRE PRESSURE

SERIES	TIRE	SLR	GVW RANGE	TRACK	WHEEL OFFSET	GROUND CLEARANCE	MAX TIRE WIDTH
G31503	LT225 75R16D	344.9	10000	1721.2	+119.4	208.2	228.0
	LT225 75R16D	344.9	11000	1721.2	+119.4	208.2	228.0
	LT225 75R16D	344.9	12000	1721.2	+119.4	208.2	228.0
	LT245 75R16E	357.5	9500	1721.2	+17.0	221.2	228.0
G31532	LT225 75R16D	344.9	11500	1721.2	+119.4	208.2	228.0
	LT225 75R16D	344.9	12300	1721.2	+119.4	208.2	228.0
	LT245 75R16E	357.9	9500	1721.2	+17.0	221.2	228.0
G31803	LT225 75R16D	344.9	10000	1721.2	+119.4	208.2	228.0
	LT225 75R16D	344.9	11000	1721.2	+119.4	208.2	228.0
	LT225 75R16D	344.9	12000	1721.2	+119.4	208.2	228.0
G31832	LT225 75R16D	344.9	11500	1721.2	+119.4	208.2	228.0
	LT225 75R16D	344.9	12300	1721.2	+119.4	208.2	228.0
G31903	LT225 75R16D	344.9	12000	1721.2	+119.4	208.2	228.0
G31932	LT225 75R16D	344.9	12300	1721.2	+119.4	208.2	228.0

G (315/318/319)(03/32) Rear Axle/Tire Data Chart

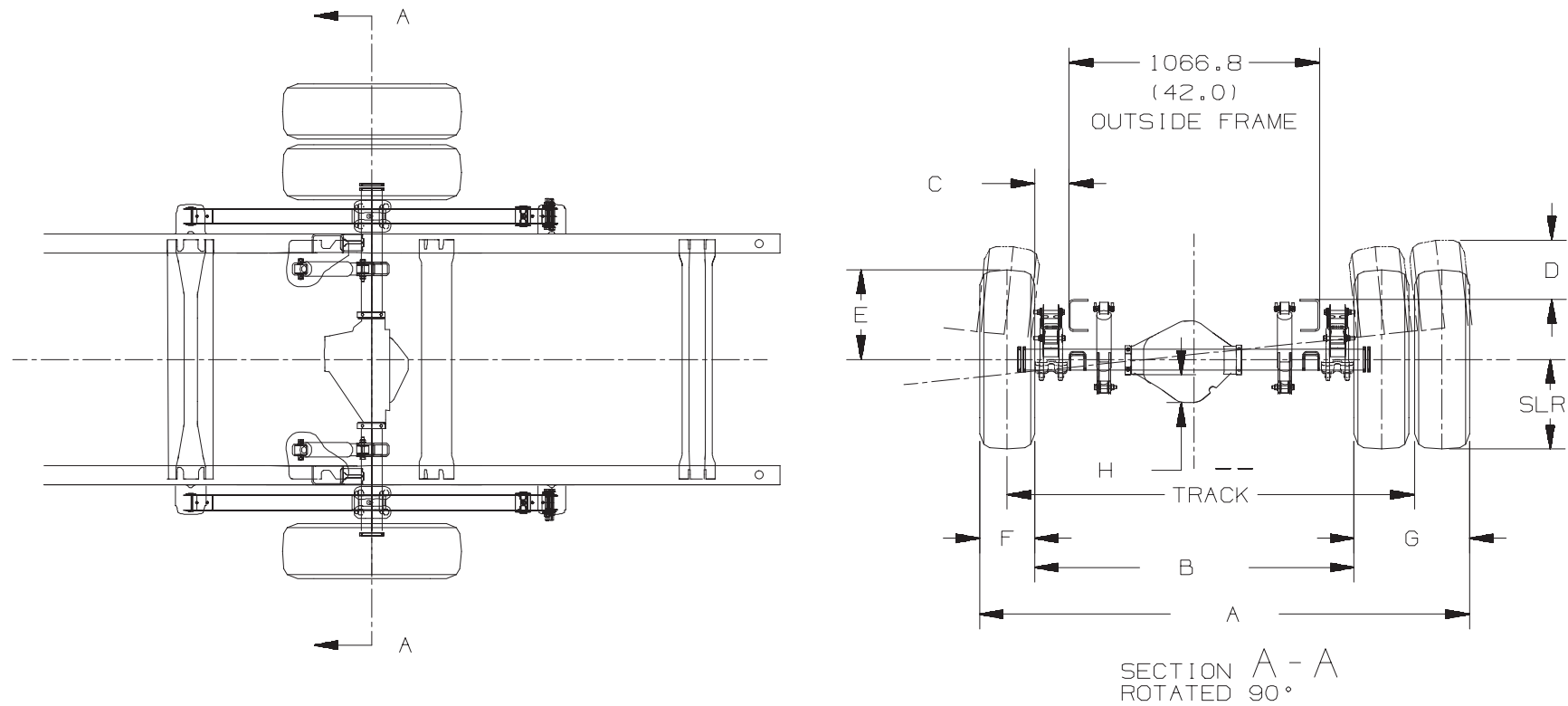

() = INCHES

* MINIMUM GROUND CLEARANCE TO BE CALCULATED BY USING GROSS AXLE WEIGHT AND RECOMMENDED TIRE PRESSURE

SERIES	TIRE	SLR	REAR WHEEL	GVW	TRACK	WHEEL OFFSET	DIM A	DIM B	DIM C	DIM D	DIM E	DIM F	DIM G	DIM H
G31503	LT245 75R16E	357.9	SINGLE	9500	1708.0	+17.0	1951.0	1465.0	199.1	226.3	394.0	243.0		173.2
	LT225 75R16D	344.9	DUAL	10000	1852.4	+127.0	2345.4	1359.4	146.3	253.4	381.0		493.0	160.2
	LT225 75R16D	344.9	DUAL	11000	1852.4	+127.0	2345.4	1359.4	146.3	253.4	381.0		493.0	160.2
	LT225 75R16D	344.9	DUAL	12000	1852.4	+127.0	2345.4	1359.4	146.3	253.4	381.0		493.0	160.2
G31532	LT245 75R16E	357.9	SINGLE	9500	1708.0	+17.0	1951.0	1465.0	199.1	226.3	394.0	243.0		173.2
	LT225 75R16D	344.9	DUAL	11500	1852.4	+127.0	2345.4	1359.4	146.3	253.4	381.0		493.0	160.2
	LT225 75R16D	344.9	DUAL	12300	1852.4	+127.0	2345.4	1359.4	146.3	253.4	381.0		493.0	160.2
G31803	LT225 75R16D	344.9	DUAL	10000	1852.4	+127.0	2345.4	1359.4	146.3	253.4	381.0		493.0	160.2
	LT225 75R16D	344.9	DUAL	11000	1852.4	+127.0	2345.4	1359.4	146.3	253.4	381.0		493.0	160.2
	LT225 75R16D	344.9	DUAL	12000	1852.4	+127.0	2345.4	1359.4	146.3	253.4	381.0		493.0	160.2
G31832	LT225 75R16D	344.9	DUAL	11500	1852.4	+127.0	2345.4	1359.4	146.3	253.4	381.0		493.0	160.2
	LT225 75R16D	344.9	DUAL	12300	1852.4	+127.0	2345.4	1359.4	146.3	253.4	381.0		493.0	160.2
G31903	LT225 75R16D	344.9	DUAL	12000	1852.4	+127.0	2345.4	1359.4	146.3	253.4	381.0		493.0	160.2
G31932	LT225 75R16D	344.9	DUAL	12300	1852.4	+127.0	2345.4	1359.4	146.3	253.4	381.0		493.0	160.2

G (114/214/217/314/317)(05/06) General Arrangement, 135"/155" Wheelbase

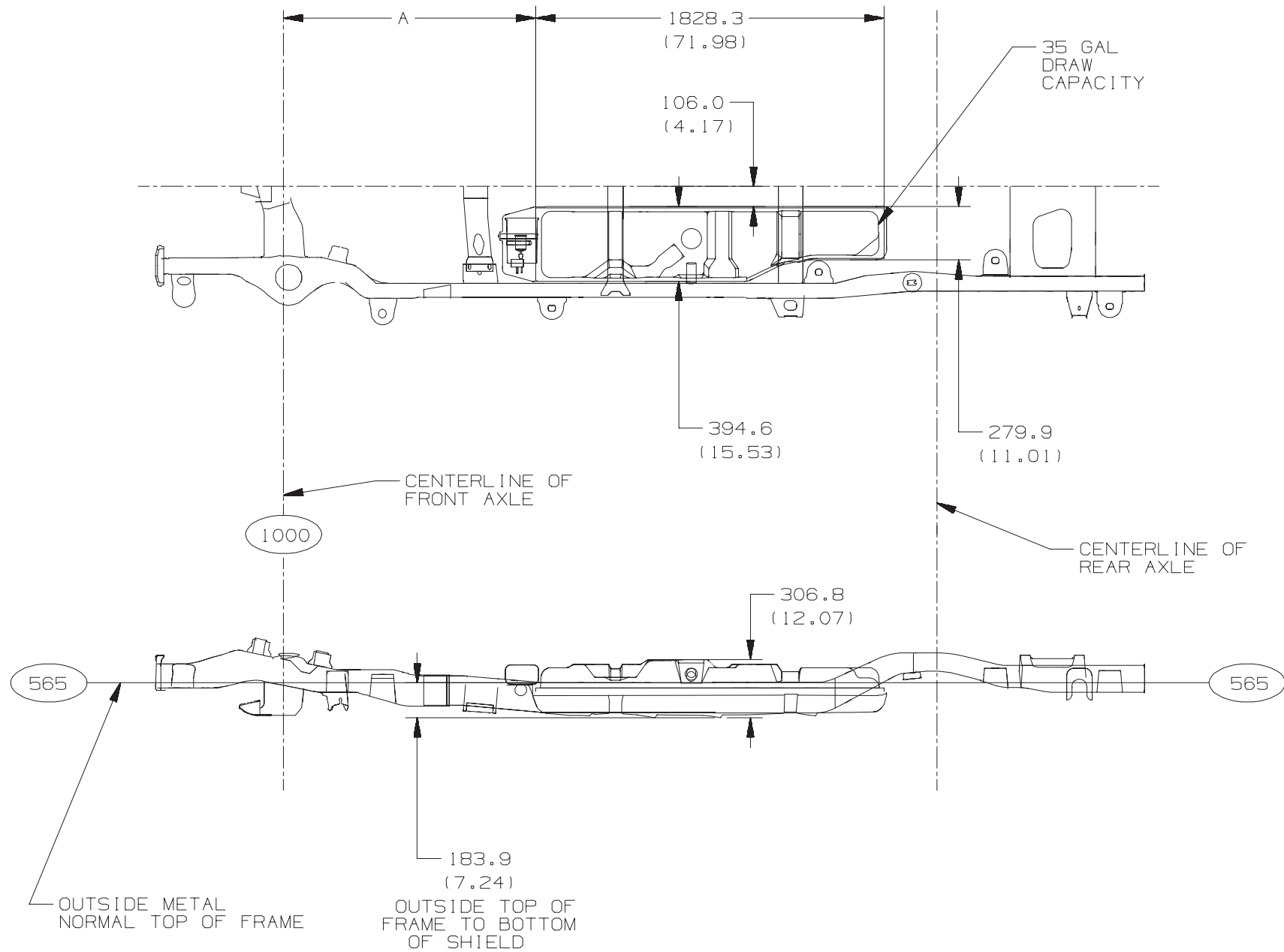

DIM	WB	
	135"	155"
A	1323.6 (52.1)	1831.6 (72.1)

() = INCHES

G (315/318/319)(03/32) General Arrangement, 35 Gallon and 55 Gallon

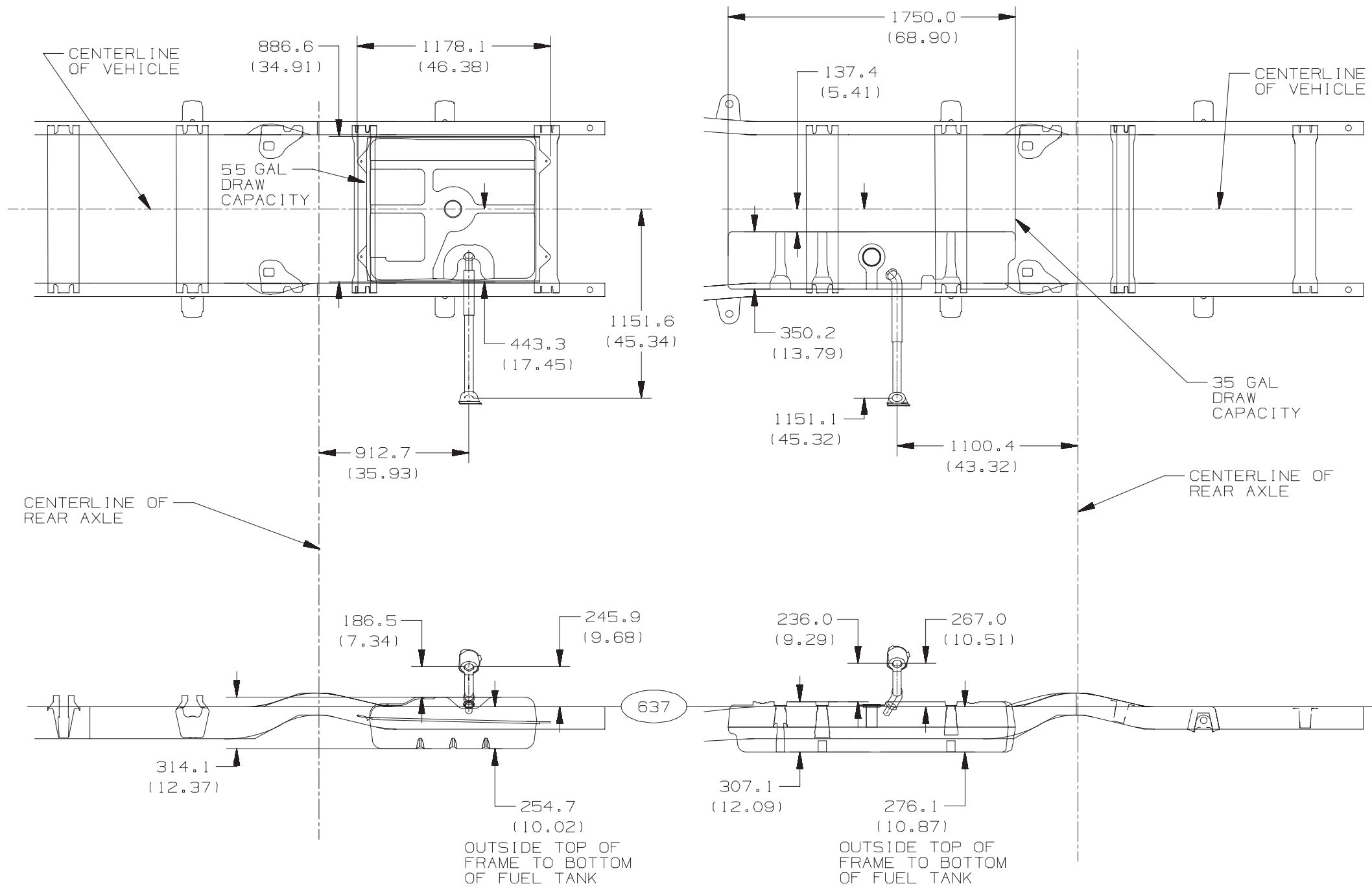

() = INCHES

G (114/214/217/314/317)(05/06) Muffler Arrangement, 135"/155" Wheelbase

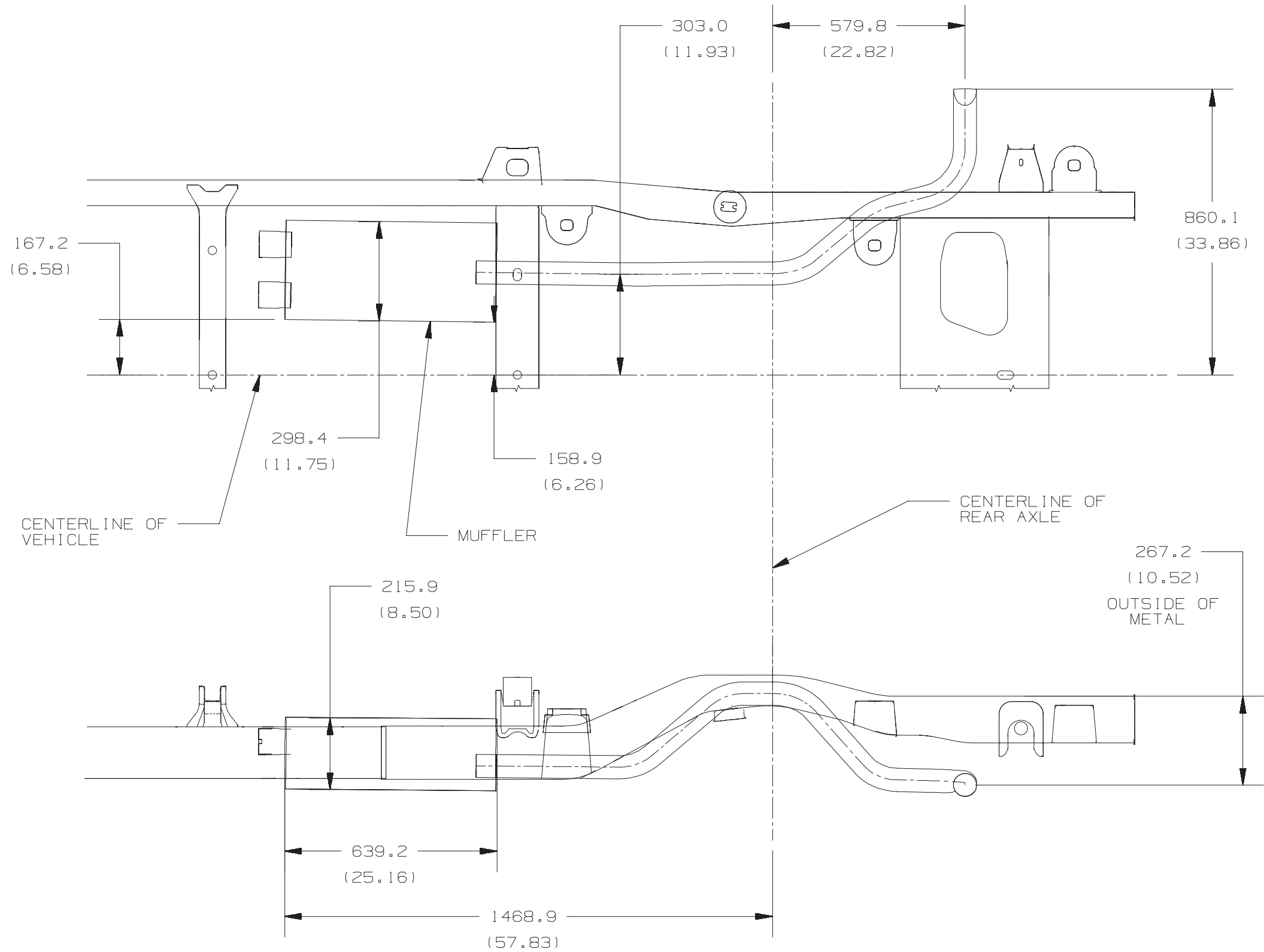

G (114/214/217/314/317)(05/06) Light Duty Converter Assembly, Engine Options L30, L31, L35

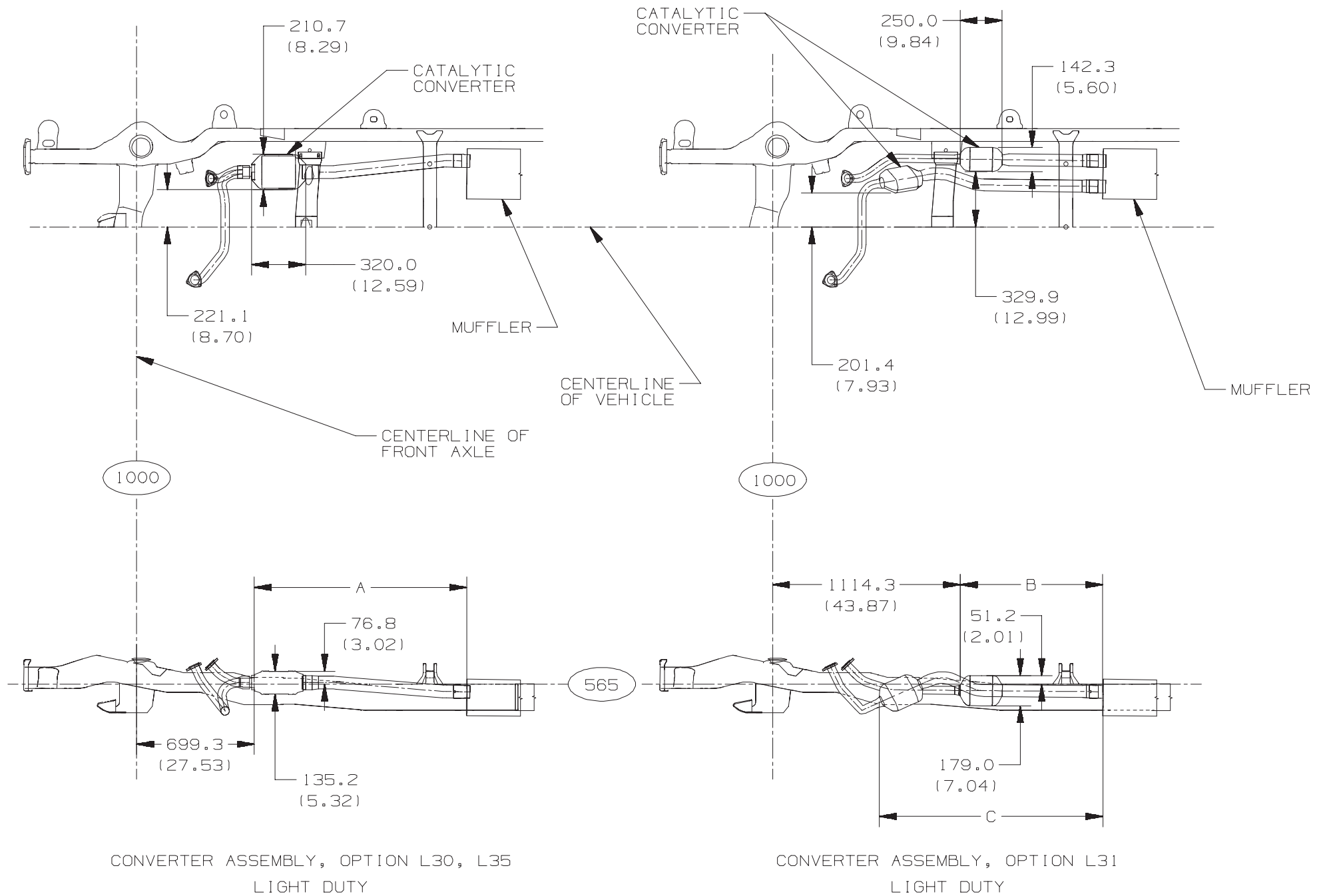

	A	B	C
135"	1262.6 (49.71)	848.0 (33.38)	1327.0 (52.24)
155"	1770.6 (69.71)	1356.0 (53.38)	1835.0 (72.24)

() = INCHES

G (217/317)(05/06) Heavy Duty Converter Assembly, Engine Options L31 California, L35

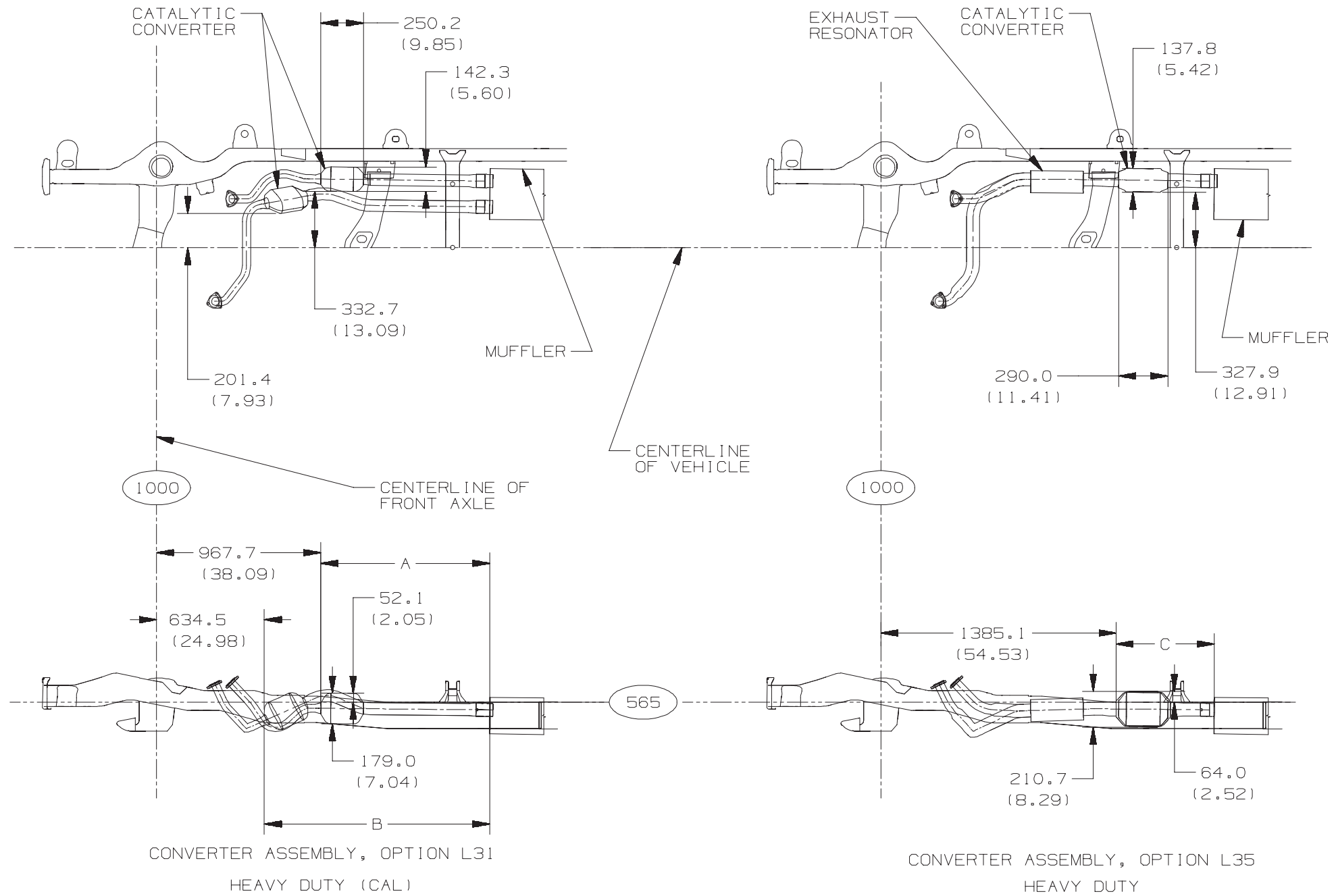

	A	B	C
135"	995.4 (39.18)	1328.6 (52.30)	578.4 (22.77)
155"	1503.4 (59.18)	1836.6 (72.30)	1086.4 (42.77)

() = INCHES

G (217/317)(05/06) Heavy Duty Converter Assembly, Engine Options L31, L29

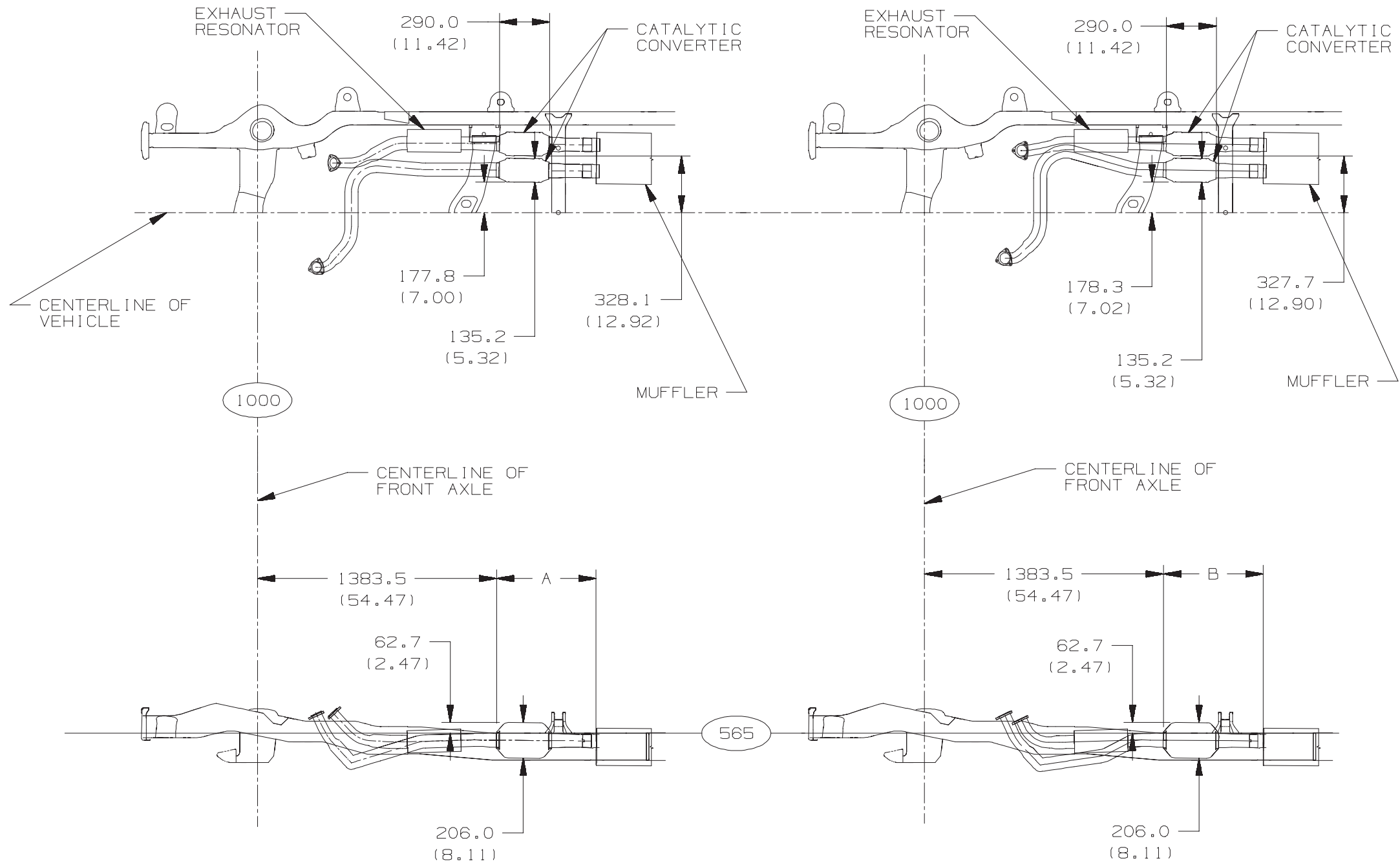

CONVERTER ASSEMBLY, OPTION L31
HEAVY DUTY

	A	B
135"	577.6 (22.74)	576.9 (22.71)
155"	1085.7 (42.74)	1084.9 (42.71)

CONVERTER ASSEMBLY, OPTION L29
HEAVY DUTY

() = INCHES

G (217/317)(05/06) Heavy Duty Converter Assembly, Engine Option L65

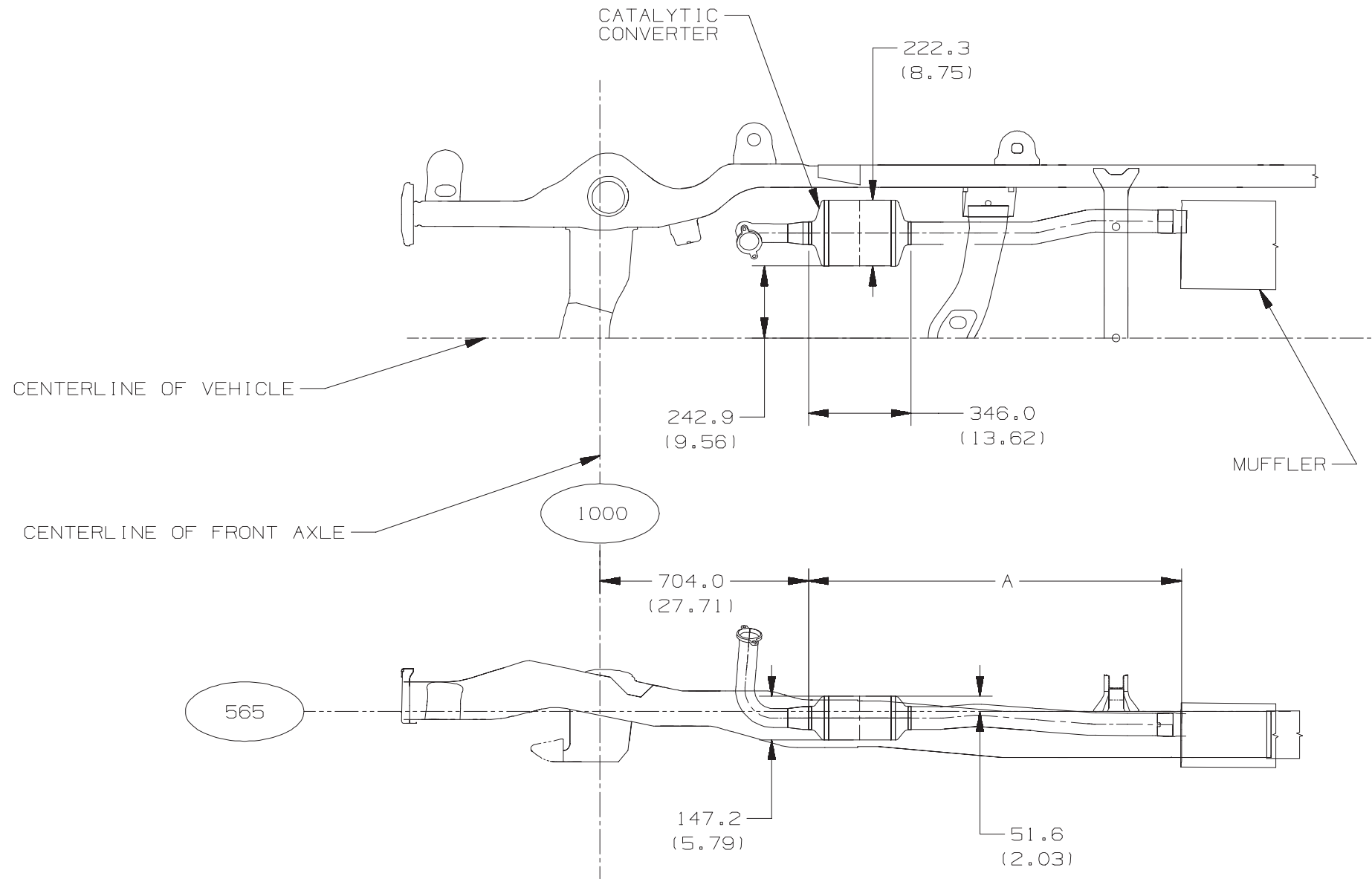

CONVERTER ASSEMBLY, OPTION L65
HEAVY DUTY

	A
135"	1259.4 (49.58)
155"	1767.4 (69.58)

() = INCHES

G 315(03/32) Heavy Duty Cutaway Converter/Muffler Assembly, Engine Option L29/L31

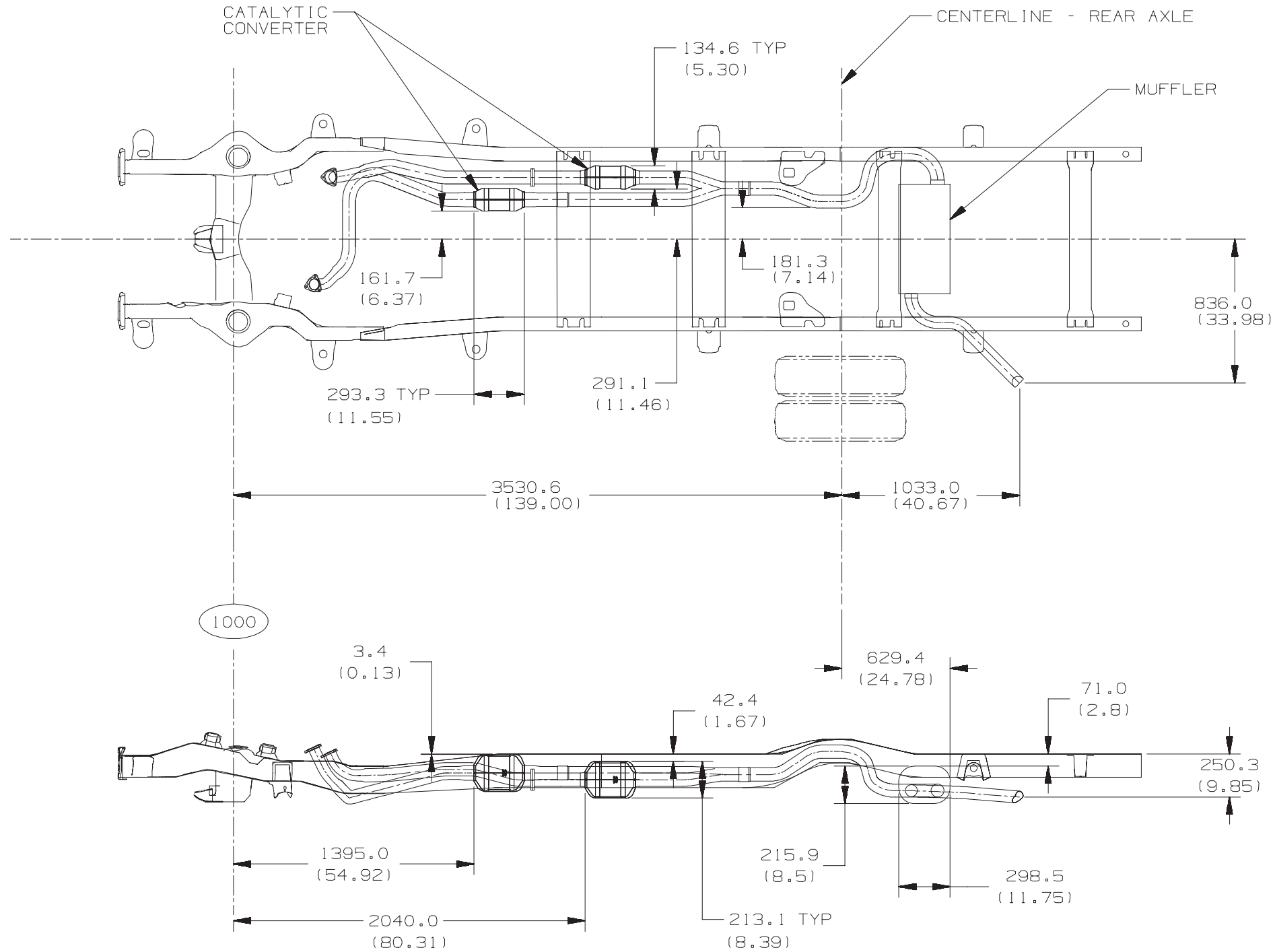

NOTES: G31500 & L29/ L31

() = INCHES

G (318/319)(03/32) Heavy Duty Cutaway Converter/Muffler Assembly, 159"/177" Wheelbase, Engine Option L29/L31

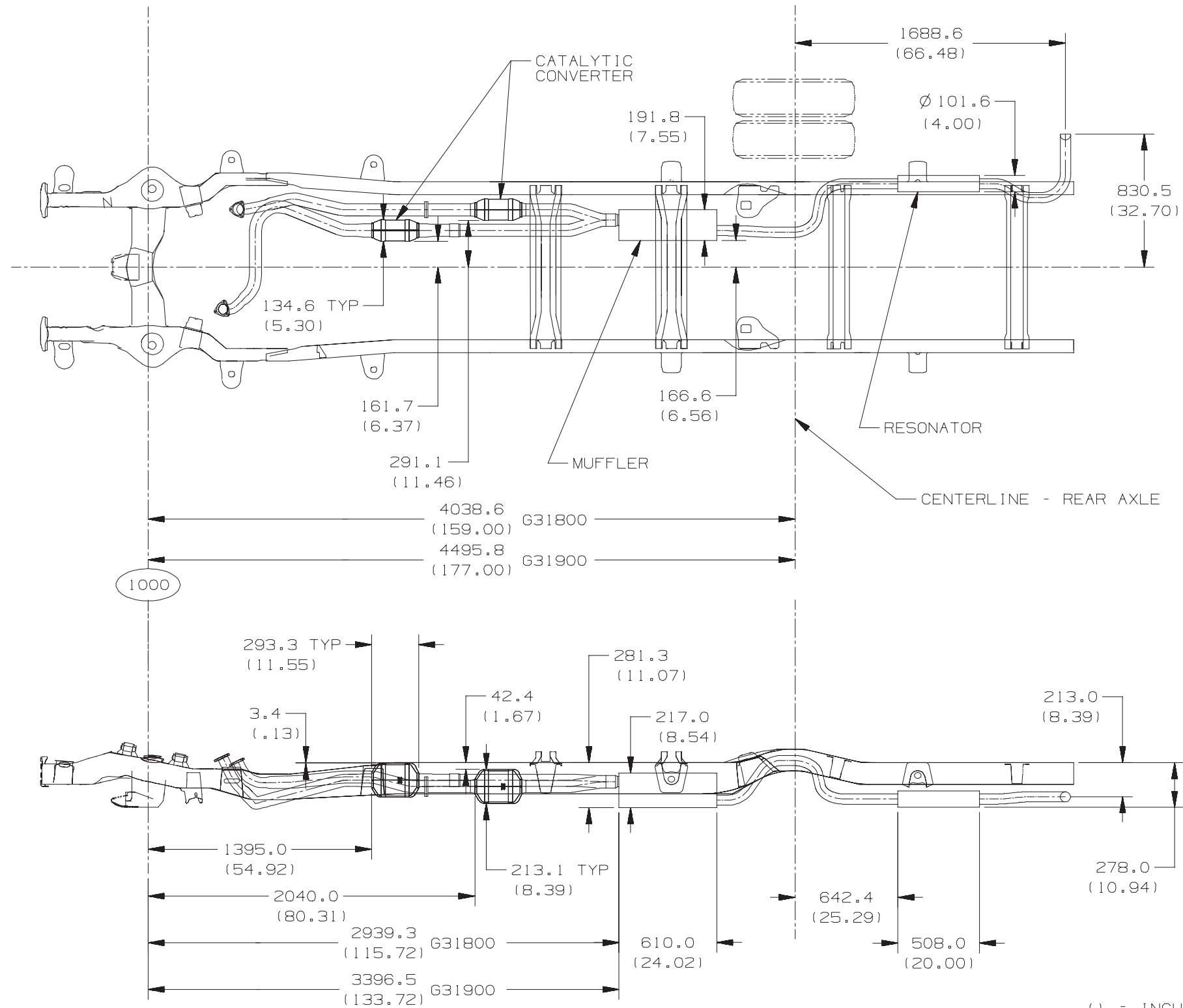

() = INCHES
 NOTES: G31800/G31900 & L29/L31

G (315/318/319)(03/32) Heavy Duty Cutaway Converter/Muffler Assembly, 139"/159"/177" Wheelbase, Engine Option L65

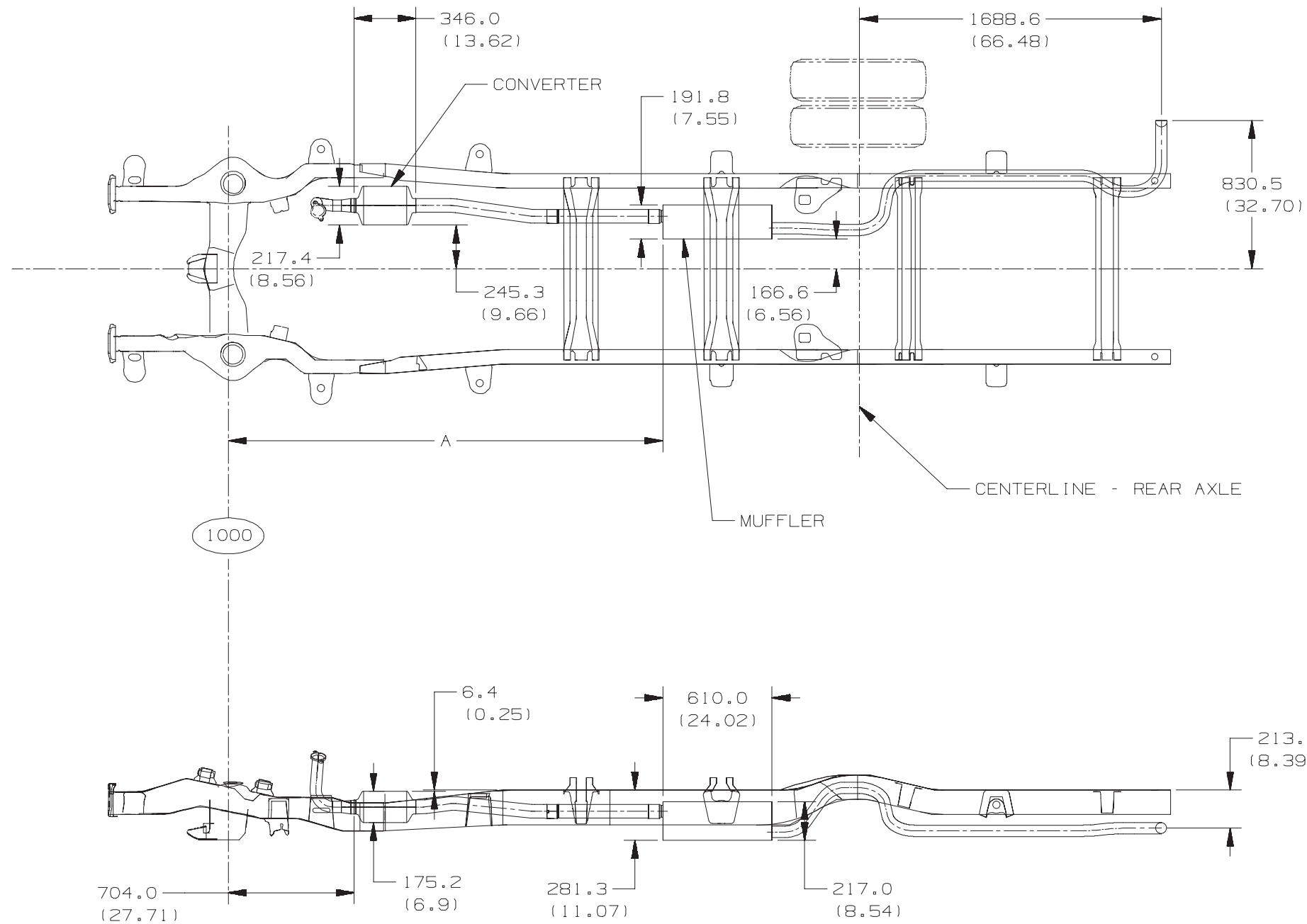

MODEL DIM	G31500 (139")	G31800 (159")	G31900 (177")
A	2431.3 (95.72)	2939.3 (115.72)	3396.5 (133.72)

() = INCHES

Ordering Information

Electrical diagrams are available from Chevrolet and GMC through service publications. They have contracted the following companies to handle the ordering and shipping of the manuals.

Helm Inc.
P.O. Box 07130
Detroit, Michigan 48207

1 (313) 865-5000 for information and inquiries

1 (800) 782-4356 for credit card orders

Routine orders will be shipped within 10 days of receipt. Rush orders will be accommodated for an additional charge.

Order forms are available upon request and orders can be paid by check or money order, made payable to the mentioned companies. Credit Card orders can be made by phone on the listed toll free phone numbers.

Notes