

BRECKWELL

Hearth Products

W3000

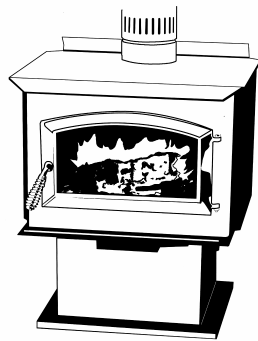

Freestanding

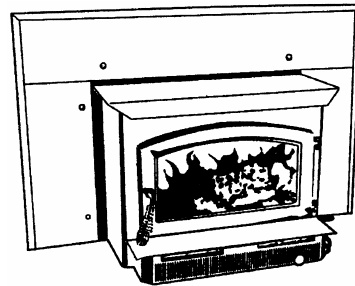

Insert

OWNER'S MANUAL

- **Warning:** If your appliance is not properly installed a house fire may result. For your safety, follow the installation directions. Contact local building or fire officials about restrictions and installation inspection requirements in your area.
- **PLEASE** read this entire manual before installation and use of this pellet fuel-burning room heater. Failure to follow these instructions could result in property damage, bodily injury, or even death.
- Save these instructions

PROFESSIONAL INSTALLATION IS HIGHLY RECOMMENDED

Manufactured by
National Steelcrafters of Oregon, Inc.
DBA Breckwell Hearth Products
Eugene, Oregon
Grand Prairie, Texas



Thank you for purchasing the Breckwell Wood Burning Stove. To achieve the safest, highest efficiency, and most enjoyable performance from your stove, you must do three things: 1) Install it properly. 2) Operate it correctly. 3) Maintain it regularly. The purpose of this manual is to help you do all three. **PLEASE read this entire manual thoroughly before you install and operate your new room heater and KEEP THIS MANUAL in a handy place for future reference. Failure to follow instructions may result in property damage, bodily injury, or even death.**

This stove has been independently tested and approved in accordance with the relevant portions of UL 1482-1996 “Solid-Fuel Type Room Heaters”.

Consult with your local building code agency or fire officials, and insurance representative before you begin your installation to ensure compliance with local codes, including the need for permits and follow-up inspections. The W3000FS and W3000I must be installed in accordance with the manufacture’s installations and with local codes.

Burn your stove moderately hot during the first couple of fires to allow the paint to cure. Do not set anything on top of the stove and clear any dust or debris off of the stove before firing. The paint will become soft and gummy as the stove heats up and will harden as the stove cools.

During the break-in period, open the door frequently (every 5 – 10 minutes) to keep the gasket from sticking to the paint as it cures.

During the paint curing process, it will emit a non-toxic smoke. Opening a window near the stove will help this to dissipate. Only High Temp Paint, available from your Breckwell dealer, should be used for touch-ups. We recommend Stove Bright #6309 – Metallic Black.

During the first few weeks, the stove will go through a process of eliminating moisture in the steel and firebrick. This moisture will reduce the initial heat output of the stove. Once the paint has cured, it will be necessary to build several hot fires to remove this moisture. For the first week or two, burn the stove with the damper wide open for an hour and use generous amounts of fuel. **DO NOT OVERFIRE THE STOVE DURING THIS PROCESS. IF THE STOVE OR CHIMNEY BECOMES RED, REDUCE THE AMOUNT OF AIR COMING INTO THE STOVE.**

Commercial and industrial installations of Breckwell Wood Stoves should not be used since operational control is often not well managed in these settings.

IMPORTANT INFORMATION

Model: W3000
 Style: _____
 Serial Number: _____
 Purchase Date: _____
 Purchased From: _____

MAIL YOUR WARRANTY CARD TODAY

To receive full warranty coverage, you will need to show evidence of the date you purchased your stove. We suggest that you attach your sales invoice to this page, and fill in the form on the left, so that you will have all the information you need in one place should the need for service or information occur.



- Never use gasoline, gasoline-type lantern fuel, kerosene, charcoal lighter fluid, or similar liquids to start or “freshen up” a fire in this stove. Keep all such liquids well away from the stove while in use.



- Do not throw this manual away. This manual has important operating and maintenance instructions that you will need at a later time. Always follow the instructions in this manual.



- Do not touch the hot surfaces of the heater. Educate all children of the danger of a high temperature stove. Young children should be supervised when they are in the same room as the stove.



- Do not place clothing or other flammable items on or near the stove.



- Never try to repair or replace any part of the stove unless instructions are given in this manual. All other work should be done by a trained technician.



- The viewing door must be closed and latched during operation.



- Never block free airflow through the open vents of the stove.



- Contact your local building officials to obtain a permit and information on any installation restrictions or inspection requirements in your area. Notify your insurance company of this stove as well.



- The exhaust system **must** be completely airtight and properly installed.



- This unit must be properly installed to prevent the possibility of a house fire. The instructions must be strictly adhered to. Do not use makeshift methods or compromise in the installation.



- Your stove requires periodic maintenance and cleaning. Failure to maintain your stove may lead to smoke spillage in your home.



- Allow the stove to cool before carrying out any maintenance or cleaning. Ashes must be disposed in a metal container with a tight lid and placed on a no combustible surface well away from the home structure.



- The exhaust system should be checked, at a minimum, at least twice a year for any build up of soot or creosote.



- This stove must be connected to a standard 115 V., 60 Hz grounded electrical outlet when using the optional blower kit. Do not use an adapter plug or sever the grounding plug. Do not route the electrical cord underneath, in front of, or over the stove.



- When installed in a mobile home, the stove must be bolted to the floor, have outside air, and **NOT BE INSTALLED IN A BEDROOM** (Per H.U.D. requirements). Check with local building officials.



- **Breckwell Hearth Products grants no warranty, implied or stated, for the installation or maintenance of your stove, and assumes no responsibility of any consequential damage(s).**

When operating your W3000FS and W3000I, respect basic safety standards. Read these instructions carefully and completely before beginning any installation procedures or attempting to operate the heater. Failure to do so may result in damage to property or personal injury and may void the product warranty.

CAUTION: WHILE THE STOVE IS BURNING, THE DAMPER ROD MUST BE FULLY OPEN BEFORE OPENING THE DOOR TO AVOID COMBUSTION FLASH.

Installation and repair of the W3000FS and W3000I Wood Stove should be done by a qualified service person. The W3000FS and W3000I, Chimney connector and chimney should be inspected by a qualified service person before the heating season, and at least once a month during the heating season to determine if a creosote build up had occurred.

Due to high surface temperatures, the W3000FS and W3000I should be located out of traffic areas and away from furniture and draperies.

Children and adults should be alerted to the hazards of high surface temperatures and should stay away to avoid burns or clothing ignition. Young children should be carefully supervised when they are in the same room as the heater.

If the blower cover plate (W3000FS) or the optional blower assembly have been removed for service, they must be replaced prior to operating the heater.

WARNING: DO NOT OPERATE HEATER WITH THE GLASS PANEL REMOVED, CRACKED OR BROKEN. REPLACEMENT OF THE PANEL SHOULD BE DONE BY A LICENSED OR QUALIFIED SERVICE PERSON.

Ensure adequate combustion and ventilation air are provided, and that they are not obstructed.

CREOSOTE – FORMATION AND NEED FOR REMOVAL

When wood is burned slowly, it produces tar and other organic vapors, which combine with expelled moisture to form creosote. The creosote vapors condense in the relatively cool chimney flue of a slow-burning fire. As a result, creosote residue accumulates on the flue lining. When ignited, this creosote makes an extremely hot fire, which may damage the chimney or even cause a house fire. In the event of a chimney fire, **CALL THE FIRE DEPARTMENT IMMEDIATELY.**

Before each heating season the entire chimney system should be professionally inspected, cleaned and, if necessary, repaired. The chimney connector and chimney should be inspected at least once a month during the heating season to determine if creosote build up has occurred. The chimney system should be inspected at the chimney connector and at the chimney top. Cooler surfaces tend to build creosote deposits quicker, so it is important to check the chimney from the top as well as from the bottom.

If creosote has accumulated it should be removed to reduce the risk of a chimney fire. The creosote should be removed with a brush specifically designed for the type of chimney in use. A qualified chimney sweep can perform this service.

INTRODUCTION	2
SAFETY PRECAUTIONS	3
SAFETY INFORMATION	4
Creosote – Formation and Need for Removal	4
INSTALLATION	6
Specifications	6
Clearances	6
Venting	7
Freestanding Installations	7
Insert Installations	7
Pedestal Assembly	8
Optional Blower Installation	8
Outside Air Kit	8
Special Mobil Home Requirements	9
Installing the Brick Panels	9
OPERATION	10
Natural Draft	10
Negative Pressure	10
Fuel	10
Building a Fire	10
Disposal of Ashes	10
Keeping the Door Glass Clean	10
Maximizing Your Stoves Efficiency	11
Achieving Long, Clean Burns	11
MAINTENANCE	12
Door	12
Gaskets	12
TROUBLE SHOOTING GUIDE	12
Poor Draft	12
Dirty Glass	12
Wood Burns Too Fast	12
Stove Emits Odor	12
Poor Heat Output	12
Smokes When Door is Open	12
REPLACEMENT PARTS LIST	13

Several issues must be addressed when selecting a suitable location for your W3000 wood stove. Observing required clearances to combustible materials, the proximity to a safe chimney, and electrical supply (if optional blower in use) must all be considered. In addition, selecting a location that takes advantage of the building's natural air flow is also desirable to maximize the heating effectiveness of the heater. In many cases, this is a central location within the building.

SPECIFICATIONS

FREESTANDING:

Width: 26"
 Height: 29 1/2"
 Depth: 21 3/4" (total - from face)
 Weight: 430 lbs.
 Flue size: 6"
 EPA status: Non-Catalytic – 2.28 Grams Per Hour
 Burn time: 7 – 9 hours
 BTU range: 9,500 to 37,000 BTU's/hr
 Approved installations:

FIREPLACE INSERT:

Width: 22 7/8" (at fireplace rear)
 26" (at fireplace opening)
 Height: 20" (in fireplace)
 Depth: 21 1/4" (total – from face)
 12 3/4" (in fireplace)
 Flashing Size: 40 1/2" W x 26 5/8" H (medium)
 48 1/2" W x 30 5/8" H (large)
 Weight: 430 lbs.
 Flashing: 13 lbs.
 Flue size: 6"
 EPA status: Non-Catalytic – 2.28 Grams Per Hour
 Burn time: 7 – 9 hours
 BTU range: 9,500 to 37,000 BTU's/hr
 Approved installations: zero-clearance, masonry

CLEARANCES

W3000FS

The stove must be placed on a continuous (grouted joints) noncombustible material such as ceramic tile, cement board, brick, 3/8" millboard or equivalent 1/2" material with a k+ .84 insulation factor, or other approved or listed material suited for floor protection. Check local codes for approved alternatives. Clearances for floor protection are measured from the sides, back, and face (door opening) as shown in figure 1.

Minimum clearance to combustibles must be maintained as shown in figure 2 and the following chart.

	A	B*	C	D*	E*	F	G	H
Single Wall Connector	24"	14"	16"	14"	7"	16"	84"	30"
Double Wall Connector	22"	12 1/2"	12"	10"	7"	16"	84"	30"
Alcove with Double Wall	22"	12 1/2"	12"	10"	7"	16"	84"	30"
Mobile Home Double Wall	22"	12 1/2"	12"	10"	7"	16"	84"	30"

*Given for reference only. Always maintain the clearances listed to the pipe.

W3000I

Minimum clearances to combustibles must be maintained as shown in figure 3 and the following chart. NOTE: Materials projecting more than 3/4" from the wall are considered mantels.

	I	J	K	L	M	N	O	P
W3000I	24"	32"	18"	9"	19 15/16"	4 9/16"	8 1/2"	12 5/8"
W3000I w/Heat Shield*	16"	24"	18"	9"	19 15/16"	4 9/16"	8 1/2"	12 5/8"

*Use only the Breckwell Heat Shield – Part Number CW-S-157.

The floor in front of the stove must be protected as shown in figure 2 and as listed below. The floor protection must also extend 8" to either side of the door opening.

When hearth protection is a minimum of 2" high (Q), The depth (R) must be a minimum of 24"

When hearth protection is a minimum of 4" high (Q), The depth (R) must be a minimum of 21"

When hearth protection is a minimum of 6" high (Q), The depth (R) must be a minimum of 18"

When the stove is installed in factory built fireplaces, 2" of clearance must be maintained under the portion of the insert that extends out over the hearth extension.

DO NOT USE MAKESHIFT MATERIALS OR COMPROMISES IN THE INSTALLATION OF THIS UNIT.

INSTALL VENT WITH CLEARANCES SPECIFIED BY THE VENT MANUFACTURER.

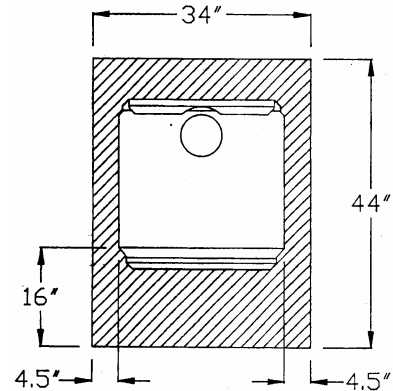

FIGURE 1

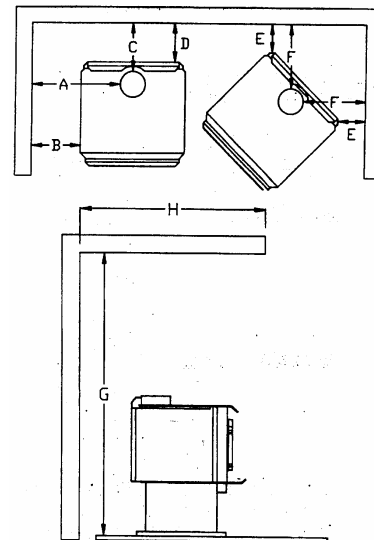

FIGURE 2

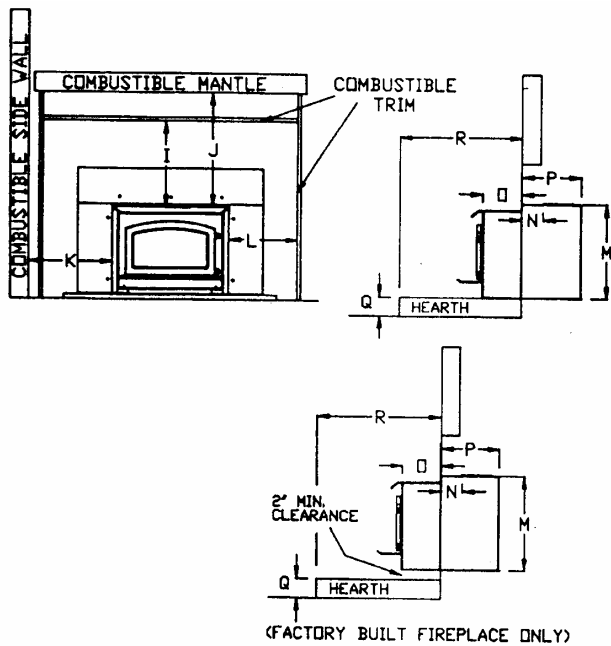

FIGURE 3

VENTING

FREESTANDING

The W3000FS is approved for use with double wall connector and the same manufacture's chimney systems as follows:

Simpson Dura-Vent Model DVL
 Selkirk Metalbestos DS
 Security Chimneys Model DL

1. Install the chimney by following the manufacture's instructions. **YOUR CHIMNEY MUST COMPLY WITH LOCAL BUILDING AND FIRE CODES.**
2. Install the first piece of pipe, crimped end down, into the flue collar on the stove ensuring an airtight connection. Continue stacking pipe in this manner until within reach of chimney. Use only an air tight slip joint to make the connection to the chimney.

All horizontal runs of pipe should be as short as possible and are required by NFPA No. 211 to have an upward pitch or rise in the same direction the smoke travels of no less than ¼" to the linear foot. The connector pipe must meet minimum clearances in any direction to walls or other combustible materials. It must attach to a listed metal chimney at least 6" in diameter with a minimum thickness of 24 gauge, or to a masonry chimney with a flue passage of at least 48 square inches.

It is required that a chimney connector pipe not extend further than the inner wall of the flue when it is connected to a masonry chimney, and that it either be cemented to the masonry or be installed without cement in a thimble connected to the masonry wall. When the connector is inserted in a thimble, the joint must be tight enough so that it will not be dislodged in normal use. Install the connector at no less than the minimum clearances from the ceiling when using a 90-degree elbow to pass through combustible constructions.

Chimney connector pipes should never pass through a floor, ceiling, firewall, and partition or combustion construction of any type unless certain precautions are taken. The best method is to use a listed thimble and a listed insulated chimney in accordance with the manufacturer's directions. NFPA No. 211 also gives some approved methods for passing a flue pipe through combustible constructions.

INSERT

INSTALLATION PROCEDURE FOR MASONRY CHIMNEY

NOTE: Although not required, a full length stainless steel liner (UL1770) is recommended for optimum safety and performance.

1. Read entire installation instructions and complete and return the warranty card.
2. Check all required clearances as specified in figure 3.
3. Open or remove the existing fireplace damper.
4. Locate the leveling nuts on each side of the outer chamber of the stove at the lower rear corners. Install the supplied carriage bolts with the head down, through each nut from the bottom sides and not extending below the stove bottom.
5. Position the stove on the hearth and in far enough so that the flue opening and the damper are aligned. The stove may need to be offset to one side to allow enough room to connect the pipe.
6. When the W3000I is installed in a Masonry chimney the stainless steel liner must directly connect at least up to the tile liner.
7. Center and push the stove in flush with the fireplace face. Adjust the leveling bolts until the stove is level.
8. Install the flashings and push the stove up snug against the face of the fireplace.

REQUIREMENTS FOR FACTORY-BUILT ZERO CLEARANCE FIREPLACE

NOTE: When the W3000I is installed in a zero clearance factory-built fireplace the liner must be 6 inch stainless steel (UL1770) and be lined to the chimney top.

1. The W3000I must only be installed in a zero clearance factory-built fireplace that is structurally sound. Fireboxes or chimneys that have flaws, burn-outs, or warpage must be replaced or repaired prior to installation. Check with your fireplace manufacturer if any problems exist.
2. All convection vents and louvers must be left unmodified and unobstructed.
3. The W3000I can be installed in factory-built zero clearance fireplaces with minimum cavity dimensions of 36 inches in width, 22 inches in height, and 14 inches in depth.
4. Modifications allowed to the factory-built fireplaces are as follows:
 - Removal of the damper.
 - Removal of the smoke shelf on the baffle.
 - Removal of the ember catches.
 - Removal of the viewing screen/curtain.
 - Removal of the side and rear bricks.
 - Removal of the fire grate.
 - Removal of the doors.

DO NOT CONNECT THIS UNIT TO A CHIMNEY FLUE SERVING ANOTHER APPLIANCE.

INSTALL VENT AT CLEARANCES SPECIFIED BY THE VENT MANUFACTURER.

PEDESTAL ASSEMBLY – W3000FS

Note: The W3000FS wood stove is heavy. Be prepared to handle the weight to avoid damage or injury. Wearing gloves during installation is recommended.

1. Carefully lay the stove on its back on carpet or other material that will prevent damage to the finish.
2. Align the mounting tabs on the pedestal with the mounting holes in the bottom of the stove making sure that the opening in the pedestal is facing the back of the stove. Using the two 3/8" x 3/8" bolts firmly tighten the pedestal to the stove.
3. Carefully stand the stove back up. If the stove is not centered on the pedestal, loosen the bolts (do not fully remove), realign the stove, and firmly retighten the bolts.

OPTIONAL BLOWER INSTALLATION

WARNING: Electrical Grounding Instructions. This appliance is equipped with a three-prong (grounding) plug for your protection against shock hazard and should be plugged directly into a properly grounded three-prong receptacle. Do not cut or remove the grounding prong from this plug.

Both blower kits contain a blower assembly and speed control unit.

W3000FS

Never operate the stove without either the blower or the blower cover in place.

1. Using a 3/8" wrench or socket, remove the 5 screws holding the blower cover plate in place. Do not discard the cover plate/ (If the blower is ever removed, the cover plate **MUST** be reinstalled) place it in the pedestal, or any other safe place.
2. Using the 5 screws from step 1, install the blower as shown in figure 4. Firmly tighten the screws, but so not over tighten as you may strip the holes out.
3. Plug the speed control into the nearest outlet. Route the fan cord so that it is not coming into contact with any part if the stove. Plug the blower cord into the speed control unit.

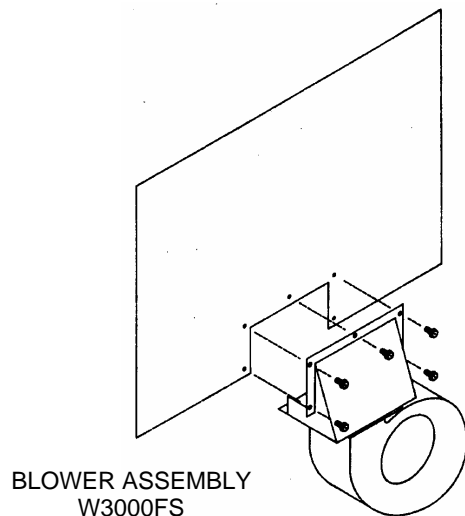
**FIGURE 4****W3000I**

1. Carefully unpack the blower assembly. Determine which side of the stove the power supply will be located. The blower comes standard with the power cord installed on the right side of the blower housing. If power outlet is on the left side, the blower cord can be rerouted to the left side by removing the rubber grommet and cord, and reinstalling on the left side in the same location.
2. Install blower assembly to the stove face by first loosening the two 1/4" cap screws underneath the ash lip. Locate the blower assembly by lining up the screws on the blower housing to the two cap screws. Slide blower housing from left to right, and then tighten the two cap screws.
3. Route the fan cord so that it is not coming into contact within part if the stove. Plug the blower cord into the power outlet.

OUTSIDE AIR KIT – W3000FS ONLY

1. Making sure that all minimum clearances are met, position the stove on the floor protection. Draw an outline around the pedestal on the floor protector. Remove the stove.
2. In the center of the outline of the pedestal foot print, cut a 4 1/2" diameter hole through the floor protector and floor. Make four 1 1/2" cuts in one end of the tube and fold out to make flaps. Insert the tube through the hole, cover it with the screen, and secure it to the floor protector.
3. Place the stove back on the floor protector. If the stove is to be fastened to the floor, use lag bolts long enough to penetrate well into the floor. Use the mounting holes provided inside the pedestal.
4. Install the pedestal cover by aligning the screw holes in the pedestal with the holes in the cover, making sure that the cover recesses into the pedestal (see figure 5).
5. Using a silicone dealer, seal all cracks between the pedestal cover and the stove, as well as cracks between the floor protector and pedestal base.

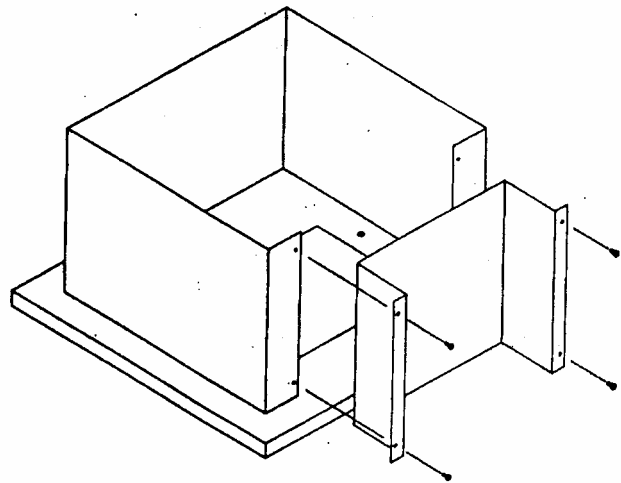
**FIGURE 5**

SPECIAL MOBILE / MANUFACTURED HOME REQUIREMENTS

WARNING: Do not install in a sleeping room.

For installation in a mobile/manufactured home, the outside air kit must be used.
(See "**OUTSIDE AIR KIT – W3000FS ONLY**")

The W3000FS must be securely fastened to the floor of the mobile (manufactured) home using the mounting bolt holes located in the pedestal of the W3000FS. Use only the holes provided.

If the optional blower is used the W3000FS must be grounded to the steel chassis of the home with 8 Ga. Copper wire using a serrated or star washer to penetrate paint or protective coating to ensure grounding.

WARNING: DURING THE INSTALLATION OF THIS STOVE, DO NOT COMPROMISE THE STRUCTUARL INTEGRITY OF THE MOBILE (MANUFACTURED) HOME WALL(S), FLOOR OR CEILING.

INSTALLING THE BRICK PANELS

The brick panels will come already installed in the W3000. The following directions are included should you ever need to remove and re-install the brick panels.

Wearing gloves is recommended when handling the brick panels.

Install the brick panels shown in figure 6 in the following order: C, A (rear), D, A (bottom). Next install the 'B' panels on the secondary tubes.
(See figures 7 & 8)

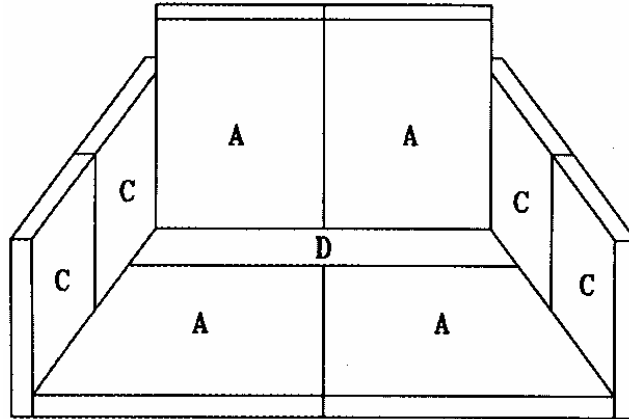
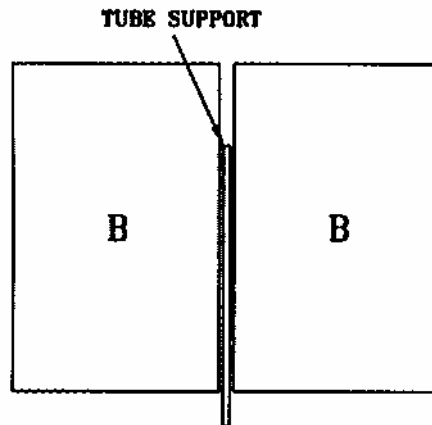
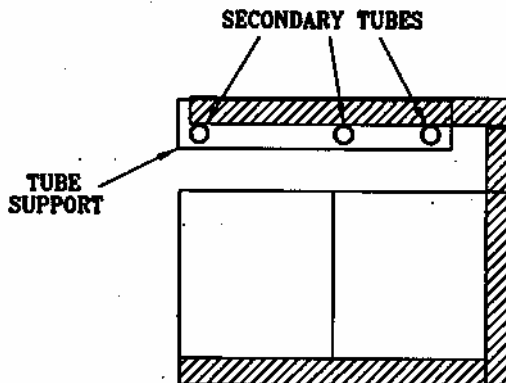

FIGURE 6



BAFFLE AREA
(TOP VIEW)

FIGURE 7



(SIDE VIEW)

FIGURE 8

BRICK SIZES

A = 10" x 12"

B = 9-3/4" x 15-1/4"

C = 9" x 7-7/8"

D = 2-7/8" x 20"

NATURAL DRAFT

The chimney serves a dual purpose of drawing combustion air into the stove and exhausting combustion by-products. Draft is the force which moves exhaust gases up the chimney (hot air rises). As the exhaust rises up the chimney, combustion air is drawn into the stove to replace it. Your stove relies on natural draft for its only source of combustion air. Poor draft can cause poor combustion and smoke. Too much draft can cause excessive burn rates and high temperature in the stove. Some of the things that can affect natural drafting are size and length of the chimney, nearby obstructions, and geographical location. Your Breckwell dealer will be able to help you match your stove to a proper chimney system.

NEGATIVE PRESSURE

This stove is not to be operated in a negative pressure area. Negative pressure can be caused by large exhaust fans in airtight homes, or by air return for a forced air heating systems in the same room as the stove. This can lead to back drafting of the stove pulling combustion exhaust into the room. An outside air source connected to the stove will not eliminate the source of negative pressure. To eliminate negative pressure problems, be sure your home has an adequate make-up air supply.

FUEL

For best efficiency and heat output, burn dry, seasoned wood only. Never burn wet wood, driftwood, wood that has been in salt water, trash, cardboard, coal, rubbish, etc. Burning fuel other than dry, seasoned wood may be illegal in some areas. Seasoned wood is wood that has been cut, split, and stored in dry, covered area in a manner that allows for free airflow around the wood for an extended period of time (6 months minimum).

BUILDING A FIRE

1. Never use gasoline, gasoline-type lantern fuel, kerosene, charcoal lighter fluid, or other similar liquids to start or 'freshen up' a fire in this heater. Keep all such liquids well away from the heater while in use.
2. Do not use a grate or any other means of elevating the fire. Always build the fire on the surface of the firebrick.
3. Pull the damper rod completely out. The damper controls the burn rate and amount of air coming in to the stove. Pulling it out allows more air in to the stove, a higher burn rate. Pushing it in lessens the air coming into the stove, a lower burn rate.
4. Crumple up some paper and place on firebrick between the front and center of brick. Cover the paper with several pieces of kindling. For a cold chimney, one or two extra pieces of paper may be placed on top of the kindling to help establish draft.
5. Light the paper and allow enough time for the kindling to get burning. Depending on the natural draft of your stove, the door may need to be left open slightly during this startup process.
6. Once the kindling is burning well more wood may be added. For best results, use gradually increasing sizes of wood before adding larger pieces for longer burns. Always allow enough time for the wood to get burning well before adding larger pieces of wood. When loading wood, always be careful not to dislodge the upper brick baffle.
7. After establishing the desired fire (about 15-20 minutes), be sure to check the exhaust for excessive amounts of smoke. Excessive smoke indicates an improper burn rate (damper setting). Readjust if necessary and recheck again after 5-10 minutes.
8. The optional fan should only be used after the stove is completely reheated. The speed should be set to match the burn rate, a low burn – low fan, a high burn – high fan.

DISPOSAL OF ASHES

Ashes should be placed in a metal container with a tight fitting lid. The closed container of ashes should be placed on a noncombustible surface or on the ground, well away from all combustible materials pending final disposal. If ashes are disposed of by soil burial or otherwise locally dispersed, they should be retained in the closed container until all cinders have been thoroughly cooled.

KEEPING THE DOOR GLASS CLEAN

No stove door glass stays perfectly clean. The most important factor in keeping the glass clean is to burn only well seasoned wood. Burning wet wood will make the glass dirty. The airwash system, which directs the incoming combustion air across the glass, is designed to help keep the glass clean. The airwash performs best at medium burn rates. The glass is also kept clean by the high temperatures inside the firebox. Cool temperatures in the firebox will cause condensation of the exhaust by-products on the glass. Do not expect the glass to stay clean during longer burn times. If your glass gets very dirty during overnight burns, try preheating the stove longer before shutting the damper down. Load wood towards the rear of the stove. Keeping freshly loaded wood away from the glass will also help. This stove will self clean by burning very hot fires, but do not over fire. **If the stove or chimney system glows, you are over firing.** Proper burning habits and an understanding of how your stove operates will help you keep your door glass clean, but remember that **no door glass will stay perfectly clean.**

MAXIMIZING YOUR STOVES EFFICIENCY

Heat transfer can be enhanced by slowing the rate of incoming combustion air, allowing more time for heat to be transferred in to your home. Slowing the rate of incoming air also slows the rate of exhaust going up the chimney and carrying heat away with it. To achieve this, always thoroughly preheat your stove before closing the damper.

The following are some tips for getting the most out of your stove:

1. Always thoroughly preheat your stove before slowing the burn rate (closing the damper).
2. Always operate your stove as much as possible in the low to medium burn rates.
3. Temperature measurements taken from the hottest point on the stove, on the top or face, can be used to repeat burn rates.
4. Do not continually operate your stove with the damper wide open. This can damage your stove and chimney. It is a waste of wood, and is very inefficient causing excessive heat loss through the chimney.
5. Periodically go outside and check your chimney. More than a very small amount of smoke indicates wasted heat, creosote build up and pollution.
6. Do not set the damper so low as to completely extinguish the flames in the firebox. Check for at least some flames 20 minutes after setting the damper. Adjust if needed.

ACHIEVING LONG, CLEAN BURNS

It is important to realize that stove technology and design have changed over the years, as well as proper operation. In older stoves the mind set was to get the stove as hot as possible before setting the damper on low for long burns. This no longer applies to your new Breckwell stove. It is still important to have the stove hot enough to burn efficiently, but this will now take less pre-heating than older stoves. After some initial experimentation, you will be able to determine the optimum operating temperatures for various burn rates. Breckwell wood stoves are emission tested to EPA standards with the damper fully closed for low burn rates. Whether or not you should burn your stove with the damper completely closed will depend on the following factors:

- Moisture content and type of wood.
- How you load your wood.
- Your chimney system.
- The temperature of the stove.

After thoroughly pre-heating the stove, using a stove/chimney thermometer, monitor the temperature on the top of the stove. Use 325 degrees as a starting point. When the top reaches the target temperature, close the damper all the way in. If the flames go completely out, open the damper all the way and then slowly close until there is a small amount of flame. Remember to check the stove in twenty minutes after adjusting the damper as it takes this long for the stove to stabilize. There should still be some small flames on or above the wood.

Try varying the target temperature in increments of 25 degrees. If the stove is burning the wood too quickly, use a lower temperature. If there are no flames in the firebox after a few minutes, use a higher temperature. You may need to burn the stove with the damper fully open for a few minutes before setting for a low burn. Never smolder a fire during a long burn. Check your chimney for large amounts of smoke as this indicates poor combustion.

Experiment with different loading methods. Fresh wood should be loaded towards the rear of the firebox, while bringing half-burned wood towards the front. If the new wood does not ignite within a few minutes, try crisscrossing the wood to allow for more airflow around the wood.

DOOR

There are a variety of high quality cleaners available that may be used to clean your brass door.

Use only products specifically made for use in wood stoves when cleaning the glass. Never scrape the glass with anything or use abrasive cleaners, as pitting may occur. Never clean glass when it is hot.

If door hinges need lubricating, never use oil; use only a high temperature anti-seize compound.

CERI-BLANKET

During every chimney cleaning the ceri-blanket should be inspected. If it has become compressed or heavily stained it needs to be replaced.

GASKETS

Periodically check the door gasket to make sure it is not over compressed (causing the door to leak). Your Breckwell dealer can supply you with the correct gasket for replacement. Never use substitute materials.

TROUBLESHOOTING**POOR DRAFT**

If your stove is not drafting properly, the chimney may be the problem. Have the chimney relined to the proper size or extend the length of the chimney (Contact your Breckwell dealer). Also refer to the section 4.1 "Natural Draft".

DIRTY GLASS

Burn smaller, hotter fires and make sure that the damper is not closed too far. Make sure the wood is well seasoned and not wet. (See "**POOR DRAFT**" above)

WOOD BURNS TOO FAST

The door gasket may be leaking. Check for leaks and replace if needed. The damper rod is too far out.

STOVE EMITS ODOR

Paint is curing. (See "INTRODUCTION")

POOR HEAT OUTPUT

Make sure the wood is well seasoned and not wet. (See "**FUEL**") The stove needs to finish curing. (See "INTRODUCTION")

SMOKES WHEN DOOR IS OPEN

Always fully open damper before opening door. Is the brick baffle dislodged? (See "**INSTALLING THE BRICK PANELS**"). Check chimney for creosote blockage. (See "**CREOSOTE**")

Contact an Authorized Breckwell Pellet Stove Dealer to obtain any of these parts. Never use substitute materials. Use of non-approved parts can result in poor performance and safety hazards.

ITEM	PART #
Blower Kit – W3000FS – Optional	AW-3000FS-BLWR
Blower Kit – W3000I – Optional	AW-3000I-BLWR
Brick Panel Set	AW-M-001S
Damper Rod Spring	C-M-010
Door Gasket	C-G-050
Door Glass	C-D-038
Door Handle Spring	CW-D-041
Outside Air Kit – W3000FS – Optional	AW-OAK
Window Gasket	C-G-033