

Pellet Stoves

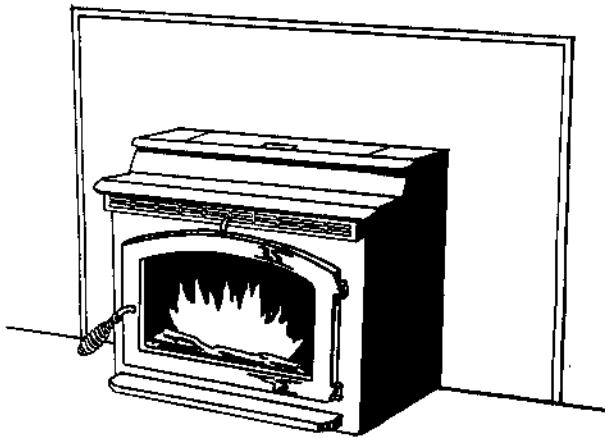

B R E C K W E L L

P23 SERIES



P23I

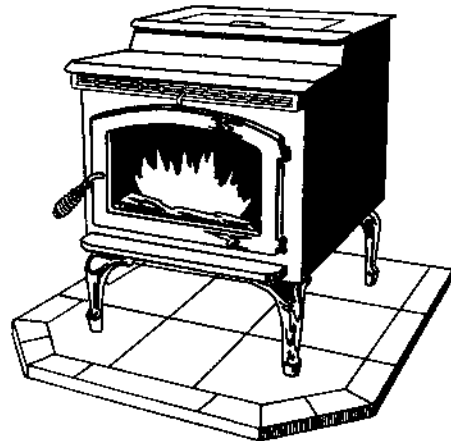

P23FS

OWNERS MANUAL

SAFETY NOTICE: If your appliance is not properly installed a house fire may result. For your safety, follow the installation directions. Contact local building or fire officials about restrictions and installation inspection requirements in your area.

FACTORY RECOMMENDS PROFESSIONAL INSTALLATION

ALL UNITS TESTED AND LISTED BY

Warnock Hersey



ICBO TL-116 NER-QA-219

Manufactured by
National Steelcrafters of Oregon Inc.
P.O. Box 24910
Eugene, Oregon 97402

©NATIONAL STEELCRAFTERS OF OREGON INC.

004961000

Thank you for purchasing the Breckwell Pellet Burning Stove. You are now prepared to burn wood in the most efficient, convenient way possible. To achieve the safest, most efficient and most enjoyable performance from your stove, you must do three things: 1) Install it properly; 2) Operate it correctly and; 3) Maintain it regularly. The purpose

of this manual is to help you do all three. **PLEASE read this entire manual thoroughly before installation and use of this pellet stove. KEEP IT in a handy place for future reference and future owners. Failure to follow these instructions could result in property damage, bodily injury or even death.**

1.0 INTRODUCTION

Your Breckwell P23 comes as a fireplace insert or a freestanding pellet stove.

This stove has been independently tested and approved in accordance with the relevant portions of ULC S627 CSA B366.2-M1983 "Standard for Space Heaters for use with Solid Fuels", UL 1482-1988 "Standard for Room Heaters", ASTM standard E1509-93, CSA C22.2 No. 3 "Electrical Features of Solid Fuel Burning Appliances", Oregon new rules for mobile homes (814-23-900 through 814-23-909) and installation as a stove heater.

This appliance is designed specifically for use only with pelletized wood. It is designed for residential installation according to current national and local building codes as a room heater. It is also approved as a mobile home heater which is designed for connection to an outside combustion air source.

The stove will not operate using natural draft, or without a power source for the blower systems and fuel feeding systems and must not be burned with any type of coal (see section 3.1).

This stove is designed to provide the optimum proportions of fuel and air to the fire in order to burn free of smoke and soot. Any blockage of the air supply to or from the stove will seriously degrade the performance and will be evidenced by a smoking exhaust and a sooting window. For the best operation the ash content of the pellet fuel should be less than 1% and the calorific value approximately 8200 BTU/LB. Avoid high ash content fuels as this will rapidly fill up the burn pot and eventually cut off the combustion air supply.

Commercial and industrial installations of Breckwell Pellet Stoves are strongly discouraged since operational control is often not well managed in these settings.

CONTENTS

2.0 Installation

2.1 Preparation

2.2 Clearances

2.3 Combustion Air Supply

2.31 When Outside Air is Not Used

2.4 Venting

2.41 Freestanding Installations

2.42 Insert Installations

2.5 Electrical Installation

2.6 Special Mobile Home Requirements

3.0 Operation

3.1 Proper Fuel

3.2 Pre-Startup Check

3.3 Building a Fire

3.31 Using Approved Fire Starter

3.32 Optional Hot Rod™

3.4 Panel Controls

3.5 Damper Control

3.6 Refueling

3.7 Shut Down Procedure

3.8 Safety Features

3.9 **Operating Safety Precautions**

4.0 Maintenance

4.1 Ash Disposal

4.11 Vacuum Use

4.2 Cleaning

4.3 Blowers

4.4 Chimney Cleaning

4.5 Recommended Maintenance Schedule

5.0 Trouble Shooting Guide

5.1 Fuel Will Not Feed

5.2 Fire Goes Out

5.3 Smoky Fire

5.4 No Power

5.5 Blowers Will Not Operate Properly

5.6 Noisy Operation

6.0 Replacement Parts and Wiring Diagram

2.0 INSTALLATION

2.1 PREPARATION

Factory packaging must be removed and some minor assembly work is required prior to installation.

Foam protective blocks must be removed from blowers and auger motor. **This is a safety precaution.** The circuit board/control panel must be unplugged and installed in the side flashing (with insert installation). Free the power cord.

NOTE: Normally, your dealer will perform these functions.

2.2 CLEARANCES

The Breckwell P23 has been tested and listed for installation in residential, mobile home, and alcove applications.

The P23 is approved for installation into masonry fireplaces.

Also factory built, built-in, zero clearance fireplaces and mobile home built-in fireplaces of the following description: all brands at least 33" wide and 20½" high. The P23 is also approved as a built-in fireplace, as long as minimum chase size and material specifications are maintained (see section 2.42D).

FLOOR PROTECTION (freestanding installation) minimum 22" wide by 31" deep. The stove must be placed on a continuous (grouted joints) non-combustible material such as ceramic tile, cement board, brick, 3/8" asbestos millboard or equivalent, or other approved or listed material suited for floor protection. Check local codes for approved alternatives.

Clearances are measured from the sides, back and face (door opening) of stove body (see figure 1A).

DO NOT USE MAKESHIFT MATERIALS OR COMPROMISES IN THE INSTALLATION OF THIS UNIT.

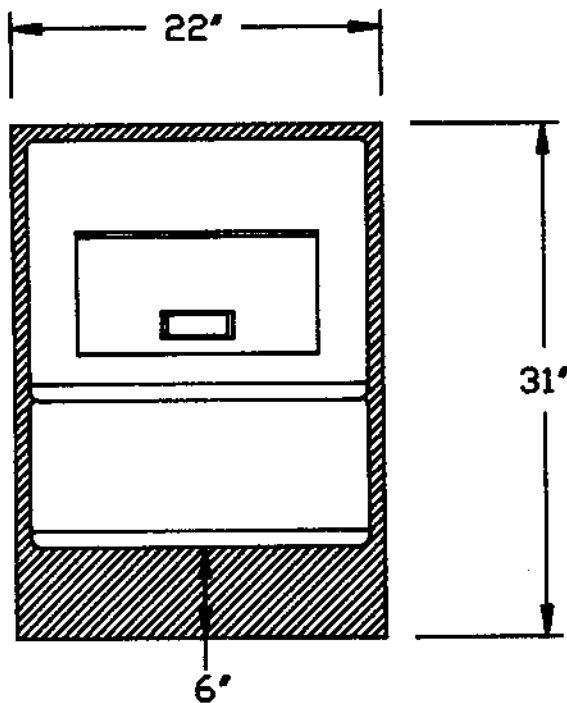

FLOOR PROTECTION
(Minimum 22" wide x 31" deep)

Figure 1A

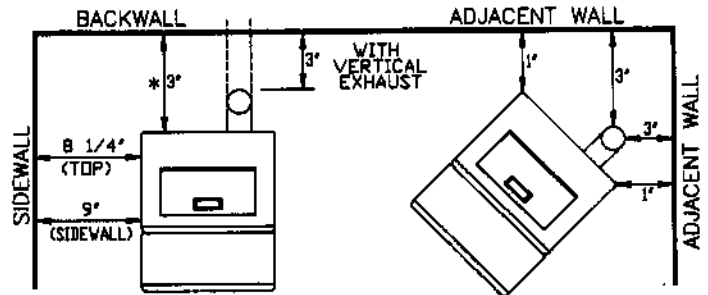

MINIMUM SIDEWALL CLEARANCES

*WITH HORIZONTAL EXHAUST

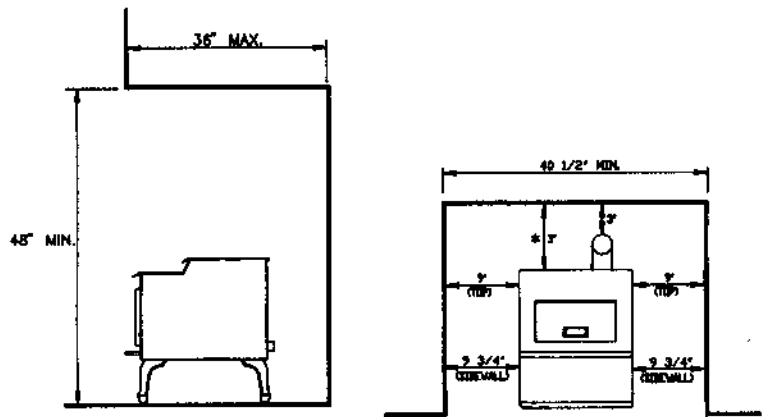

ALCOVE CLEARANCES

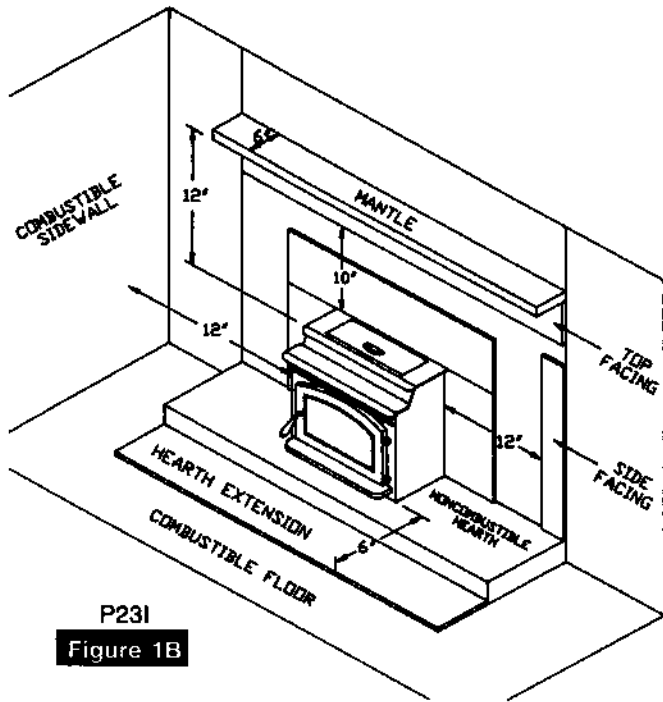

P23I
Figure 1B

2.3 COMBUSTION AIR SUPPLY

For mobile home installation the stove must be connected to an outside source of combustion air. A 1 3/4" inside diameter metallic pipe, either flexible or rigid should be used when outside air is to be connected. It attaches to an outlet at the stove's rear (see figure 2) and its terminus should have a wind hood or be turned 45° to prevent overdraft when located on windy side of home. In some cases rodent guards are required.

Sources of Outside Combustion Air

- A. In fireplaces
 1. Ash cleanout door
 2. Masonry fireplaces only — hole drilled in rear of firebox (when fireplace is on an outside wall)
 3. Top of chimney (see figure 10).
- B. For freestanding installations
 1. Hole in floor near stove rear
 2. Hole in wall behind stove

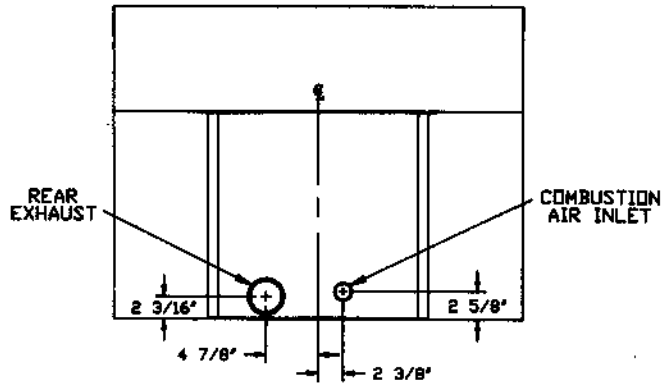

REAR VIEW P23 — INSERT INSTALLATION

Figure 2B

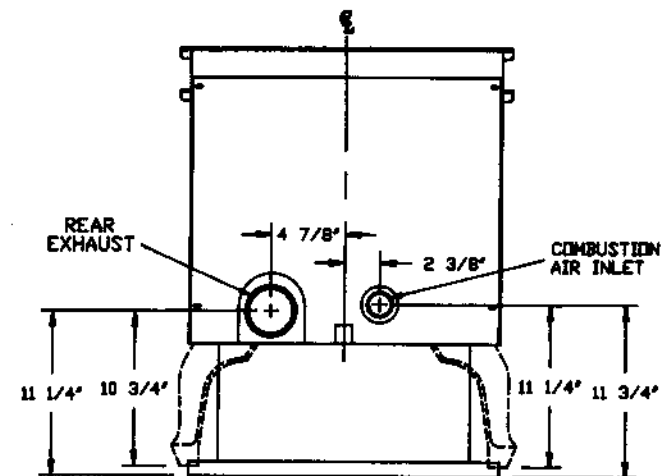

P-23FS REAR VIEW
(FREESTANDING INSTALLATION)

Figure 2A

2.31 WHEN OUTSIDE AIR IS NOT USED

If outside air is not used, it is important that combustion air is easily available to the inlet. In insert installations, **flashing vents should not be restricted**. The flashing should not seal the fireplace face.

2.4 VENTING

The Breckwell P23 is certified for use with listed TYPE L vent, 3" or 4" diameter in size. The stove was tested with Simpson Duravent brand. Class "A" chimney is not required. An L-vent adapter is provided with the stove.

Refer to the instructions provided by the vent manufacturer, especially when passing through a wall, ceiling or roof. Do not connect this unit to a chimney flue serving another appliance.

Do not install a flue damper in the exhaust vent of this unit. This is a pressurized exhaust system. The pipe joints should be sealed to insure consistent performance and avoid smoke spillage.

Equivalent Vent Length (EVL)

The longer the run of pipe in your installation (both with inserts and freestanding), the more restriction there is in the system. Therefore, larger diameter pipe should be used. Here is how you determine whether 3" or 4" should be used in your installation.

If you have over 15 feet of equivalent vent length, we recommend the use of 4" pipe.

To calculate EVL, use the following conversions:

90° elbow or "T"	= 5 equivalent feet
45° elbow	= 3 equivalent feet
Horizontal Pipe Run	= 1 equivalent foot per actual foot
Vertical Pipe Run	= 0.5 equivalent feet per actual foot

NOTE: At altitudes above 3,000 feet, we suggest the use of 4" diameter vent at an EVL of 7 feet.

2.41 FREESTANDING INSTALLATIONS

A. Assembling PEDESTAL SET

Follow instructions inside Breckwell P23 Pedestal Set (A-P23-P), (see figure 3)

B. HORIZONTALLY THROUGH WALL (see figure 4)

NOTE: Follow L-Vent Chimney manufacturer's instructions.

1. Position stove, adhering to clearances shown in section 2.0.
2. Locate position of hole in wall, directly behind stove's exhaust vent (see figure 2).
3. Install L-Vent wall thimble per L-Vent manufacturer's instructions.
4. Attach enough pipe to penetrate and extend at least 6" beyond exterior walls. An eight foot vertical pipe run is suggested where possible to reduce the possibility of smoke leakage in the event of a power failure.
5. Attach L-vent adapter to rear exhaust. Seal with metallic tape.
6. Attach cap and seal outside wall thimbles with non-hardening waterproof mastic.
7. Termination should not be located such that hot exhaust gases can ignite trees, shrubs, grasses, or be a hazard to children. Exhaust gases can reach temperatures of 500°F and cause serious burns if touched. Locate termination: a) not less than 3 feet above any forced air inlet located within 10 feet; b) not less than 4 feet below or horizontally from, or one foot above any door, window or gravity air inlet into any building; c) not less than two feet from an adjacent building and not less than 7 feet above grade when located adjacent to a public walkway.

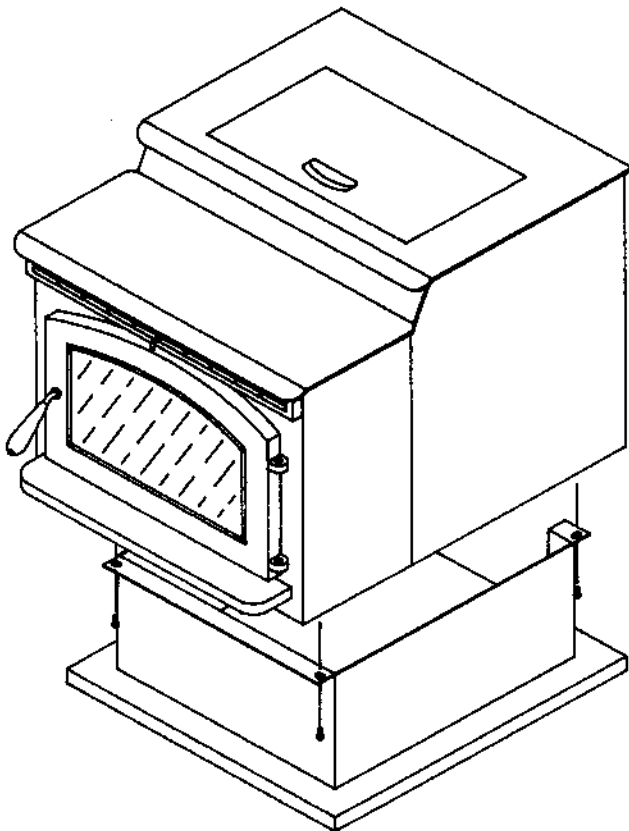

FIGURE 3

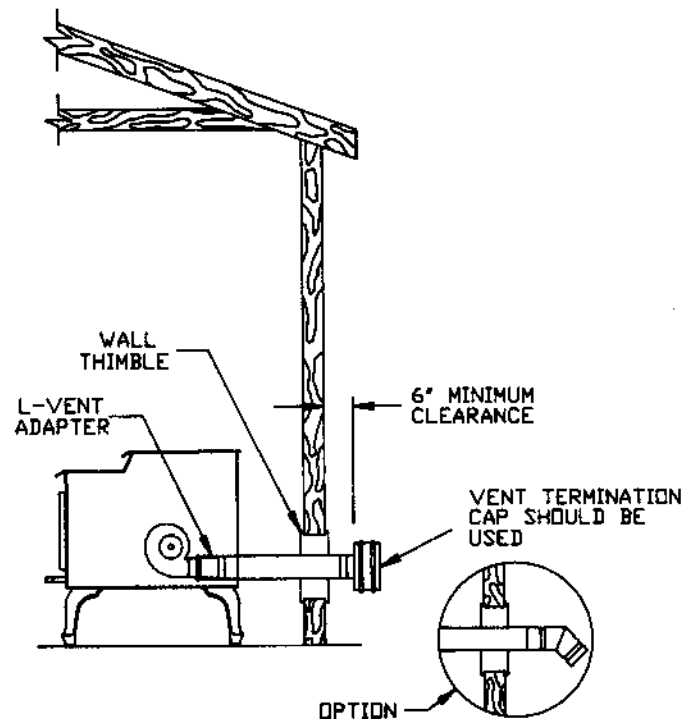

Figure 4

C. VERTICALLY WITH NEW CHIMNEY SYSTEM

(see figure 5)

NOTE: Follow L-Vent Chimney manufacturer's instructions

1. Attach L-vent adapter to rear exhaust. Attach 90° elbow or cleanout TEE (recommended). If you wish to center chimney system, position elbow or TEE at 45° angle (see figure 5). Attach a 45° elbow.

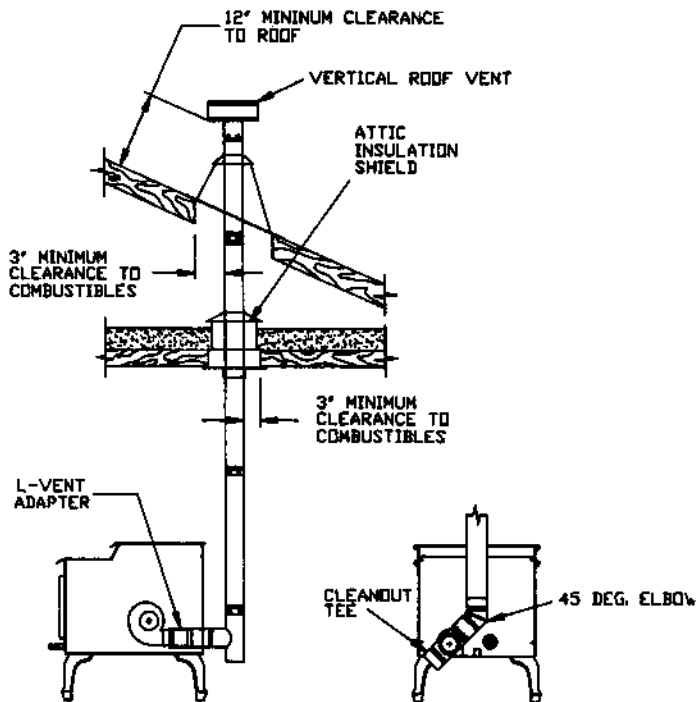

P-23 REAR VIEW

(CENTERED EXHAUST INSTALLATION)

VERTICALLY WITH NEW CHIMNEY

Figure 5

2. Locate stove, drop plumb bob to center of flue outlet, mark point on ceiling. Install ceiling support and L-Vent pipe per L-Vent manufacturer's instructions.
3. Always maintain 3" clearance from combustible materials. When passing through additional floors or ceilings always install firestop spacer.
4. After lining up for hole in roof, cut either round or square hole in roof, always 3" larger all the way around pipe. Install upper edge and sides of flashing under roofing materials, nail to the roof along upper edge. Do not nail lower edge. Seal nail heads with non-hardening waterproof mastic.
5. Apply non-hardening, waterproof mastic where the storm collar will meet the vent and flashing, slide storm collar down until it sets on the flashing, seal and install cap.

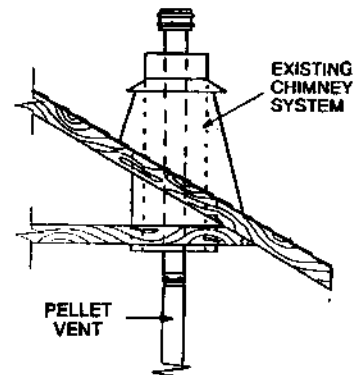
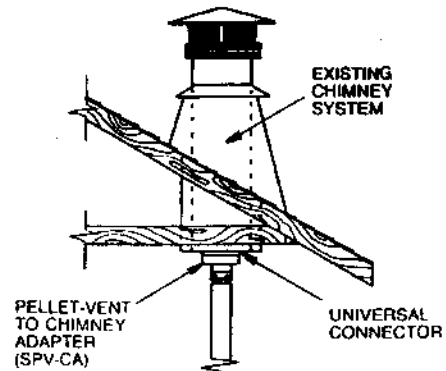

RECOMMENDED METHOD

VERTICALLY USING EXISTING CLASS "A" CHIMNEY

Figure 6

D. VERTICALLY INTO EXISTING CHIMNEY SYSTEM

(see figure 6)

Follow steps 1 and 2 in previous section (2.41C), then attach to existing system.

Adapters are available to adapt from 3" L Vent to 6" or 8" Class A chimney. As an alternative, 3" or 4" L Vent can be run inside existing chimney to termination. This is the preferred method. Follow guidelines for equivalent vent length.

2.42 INSERT INSTALLATIONS

Insert installations must be vented with 3" or 4" pipe. Pipe may be single wall stainless steel flexible pipe. Vent may terminate within chimney beyond a blanking plate or extend to the chimney top. See section 2.3 for outside air access information.

The fireplace and chimney should be cleaned thoroughly before starting installation. We suggest painting the interior of particularly old and dirty fireplaces to seal any odors. In zero-clearance fireplace installations, when the fireplace opening is above the floor or raised hearth, the adjustable "Breckwell P23 Z-C skirt" can be used to bridge the gap between hearth and stove bottom (see figure 7).

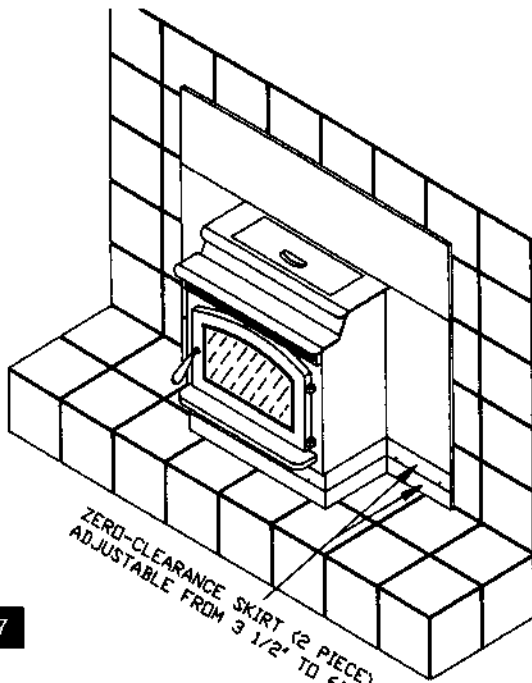

Figure 7

A. ASSEMBLING FLASHING SET

Follow instructions packed with P23 Flashing Set (A-P23-F). (see figure 8)

B. WHEN VENT PIPE EXTENDS TO CHIMNEY TOP

1. You will need a pipe length equal to the chimney height (from hearth) plus six inches. If outside combustion air is to be used, you will need a pipe length (see section 2.3) equal to the chimney height plus 12 inches.
2. Attach cerablanket wrap, which comes with stove, to that end of vent pipe that will connect to stove. Use 12" lengths of light gauge metal wire (not included) or metallic tape. This is to protect interior components from excess heat.
3. Set insert on hearth, adjust leveling bolts on rear sides, slide in far enough to attach vent pipe (and combustion air pipe if used). Use RTV, metallic tape, and/or self tapping screws to assure tight connection.
4. Attach flashing (see figure 8), route power cord out the side nearest a 120V receptacle. Slide in insert.
5. Measure and build chimney top. Cut out holes for vent pipe (and combustion air pipe if used). Install and seal with non-hardening mastic to prevent water leakage. Install vent cap.

C. WHEN VENT PIPE EXTENDS THROUGH CHIMNEY BLANKING PLATE

1. You will need a pipe length that extends 12" above the blanking plate. **NOTE:** This installation is optional but not recommended. Outside combustion air cannot be drawn from chimney cavity in this installation.
2. Attach cerablanket as in section B.
3. Measure and build blanking plate. Cut out hole for vent pipe (and combustion air intake pipe, if used). Install and carefully seal blanking plate as in previous step 5. Failure to properly seal may result in smoke spillage.
4. Slide vent pipe (and intake pipe if used) up through blanking plate hole, leaving enough to grab and pull down.
5. Set insert on hearth, complete steps 4 and 5 in 2.42B. Be sure to seal where pipe passes through blanking plate.

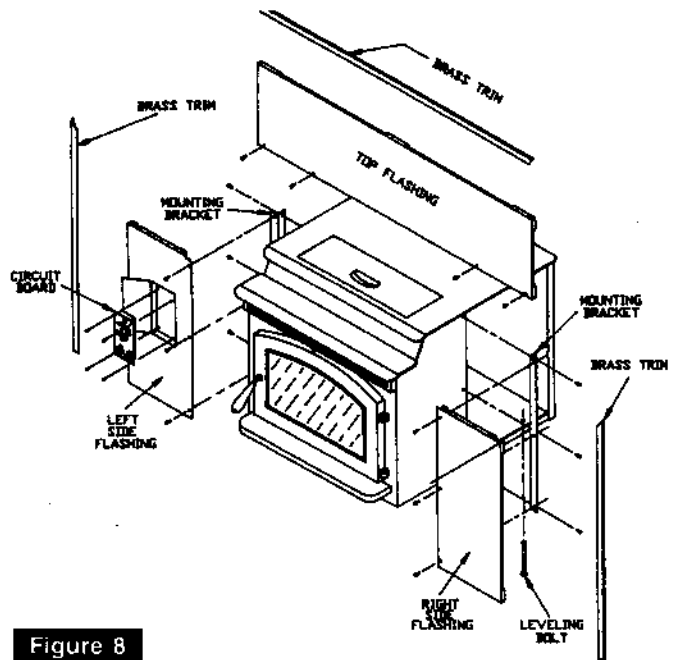

Figure 8

NOTE: FOLLOW METAL CHIMNEY INSTALLATION INSTRUCTIONS

FIREPLACE INSERT SIDE ELEVATION VENT SYSTEM

NOTE: WHEN MANTLE EXTENDS MORE THAN 6" FROM FIREPLACE FACE A 15" MIN. DIMENSION MUST BE MAINTAINED FROM STOVE TOP TO BOTTOM OF MANTLE.

EXHAUST PIPE INSTALLATION

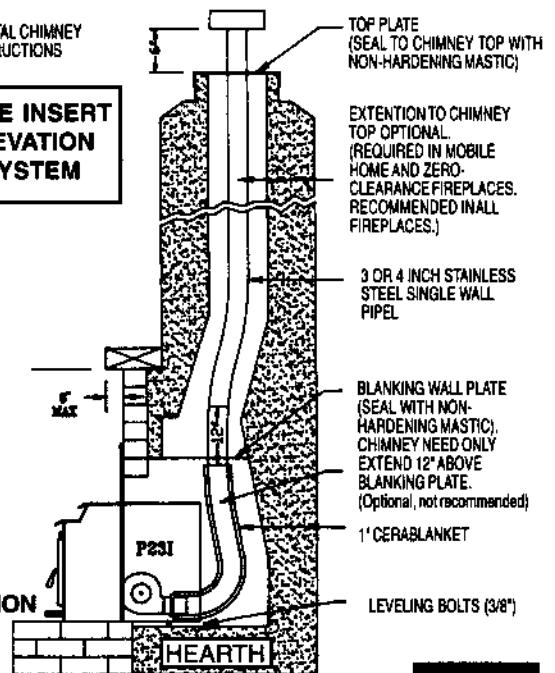

Figure 9

D. AS A BUILT-IN FIREPLACE

Figures 11A & 11B describe a P23 installation vented into either a special chase built outside an outer wall or a false inside wall. **This is especially suited for new construction or remodeling. The chase dimensions shown are minimums and must be maintained.**

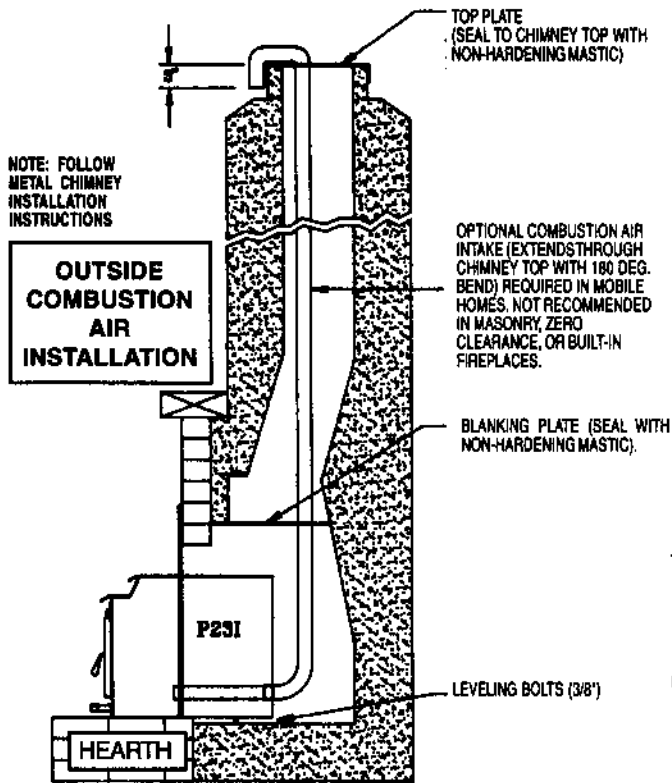

Figure 10

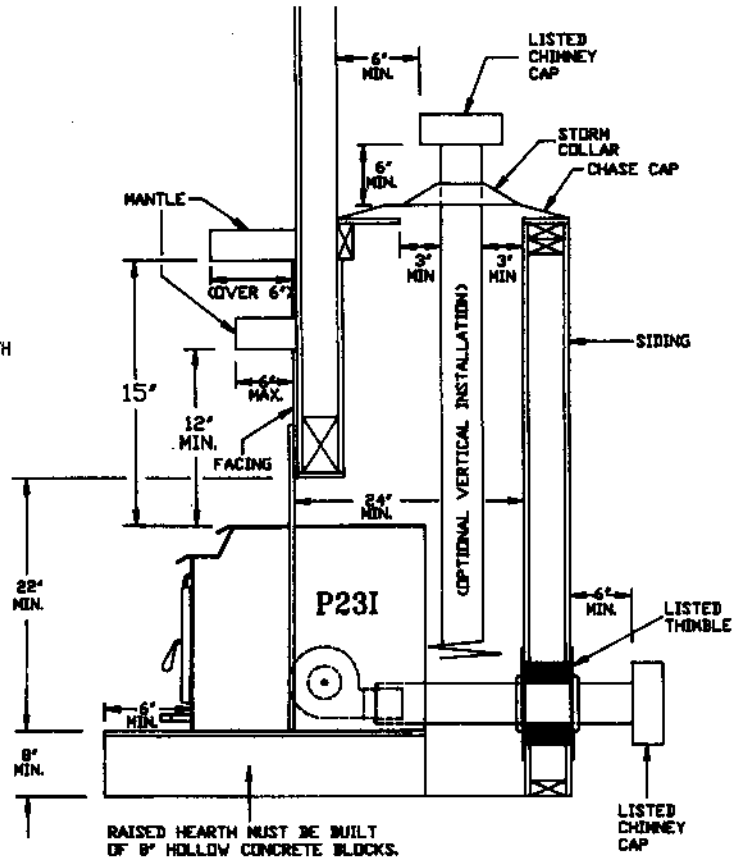

Figure 11B

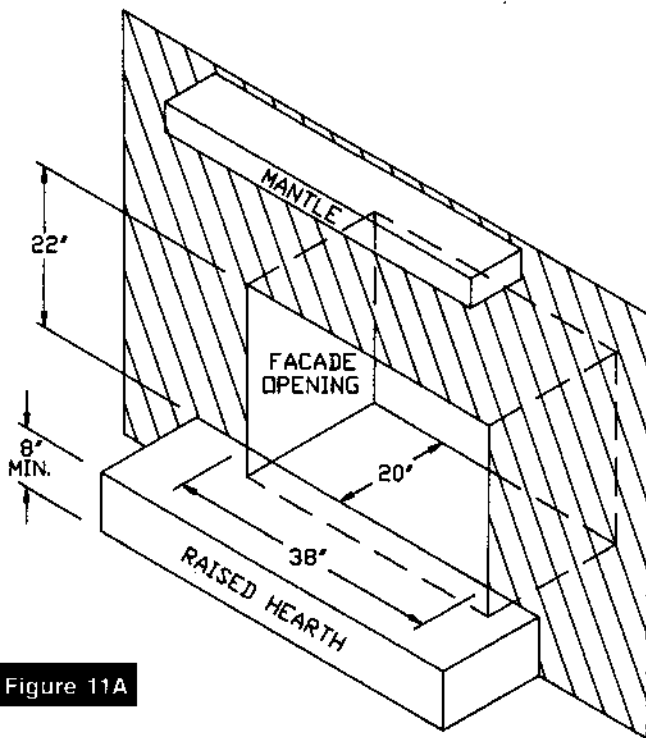

Figure 11A

2.5 ELECTRICAL INSTALLATION

This stove is provided with an 8-foot grounded electrical cord extending from the rear of the stove. This should be connected to a standard 3 prong 120 volt, 60 hz electrical outlet. Voltage variations can lead to serious performance problems. The Breckwell electrical system is designed for 120 volts AC with no more than 5% variation. National Steelcrafters of Oregon, Inc. cannot accept responsibility for poor performance or damage due to inadequate voltage. If connected to an older two-prong outlet, a separate ground wire should be run to a proper ground (refer this to a qualified electrician).

2.6 SPECIAL MOBILE HOME REQUIREMENTS

Mobile Home installations made prior to the initial sale of the mobile home are governed by US Department of Housing and Urban Development (HUD) standards. These standards include the following: a. Stove should be grounded, with #8 copper wire and terminated with NED approved grounding device; b. Stove should be attached to mobile home during shipment.

WARNING: Do not install in a sleeping room.

CAUTION: The structural integrity of the mobile home floor, wall and ceiling/roof must be maintained.

3.0 OPERATION

3.1 PROPER FUEL

THIS STOVE IS APPROVED FOR BURNING PELLETIZED WOOD FUEL ONLY! Factory-approved pellets are those 1/4" or 5/16" in diameter and not over 1" long. Longer or thicker pellets sometimes bridge the auger flights which prevents proper pellet feed. Burning wood in forms other than pellets is not permitted. It will violate the building codes for which the stove has been approved and will void all warranties. The design incorporates automatic feed of the pellet fuel into the fire at a carefully prescribed rate. Any additional fuel introduced by hand will not increase heat output, but may seriously impair the stove's performance by generating considerable smoke. Do not burn wet pellets. The stove's performance depends heavily on the quality of your pellet fuel. Avoid pellet brands which display these characteristics:

- Excess Fines — "fines" is a term describing crushed pellets or loose material that looks like sawdust or sand. Pellets can be screened before being placed in hopper to remove most fines.
- Binders — Some pellets are produced with materials to hold them together, or bind them.
- High ash content — Poor quality pellets will often create smoke and dirty glass. They will create a need for more frequent maintenance. You will have to empty the burn pot and ash pan plus vacuum the entire system more often. Poor quality pellets could damage the auger. National Steelcrafters of Oregon, Inc. cannot accept responsibility for damage due to poor quality pellets. Your dealer can recommend a good quality pellet in your area.

3.2 PRE-START-UP CHECK

Clean firebox of all residue ash. Remove imitation log set, if in use. Then remove burn pot and dump ash, making sure no air holes are blocked. Ash should be placed in a metal container with lid. Replace burn pot. Clean door glass if necessary (a dry cloth is usually sufficient). Check fuel in hopper and refill if necessary.

NOTE: Hopper capacity is approximately 50 lbs.

3.3 BUILDING A FIRE

NOTE: During the first few fires, your stove will emit an odor as the high temperature paint cures or becomes seasoned to the metal. Maintaining smaller fires will minimize this. Avoid placing items on stove top during this period as paint could be affected.

3.3.1 Using Approved Fire Starter

- Check to make sure power cord from stove is plugged in.
- Push damper control rod (located on left side of stove) all the way in.
- Fill burn pot by hand or by pressing "MANUAL FEED" switch on control panel (see figure 12) to just below bottom row of air holes. Add approved fire starter (see section 3.92j), light and close door. Keep door tightly closed during operation.

- Push on/off switch to "ON" position. Make sure you don't push switch beyond "ON" to "High Fan". Blowers will come on. Set fuel control knob to medium or high. Push "AUGER" button.

- After auger begins feeding pellets, readjust damper (see section 3.6)

NOTE: Auger will not begin feeding pellets until the firebox reaches a preset temperature level (about 10-15 minutes).

3.3.2 Using an optional Hot Rod™ automatic fire starter:

- Fill hopper and clean burn pot.
- Push on/off switch to on position.
- Prime auger by pressing manual feed switch until pellets start to drop in burn pot.
- Set fuel control knob to "C" setting.
- Open damper 1/4" and press "auger" button.
- Fire should start within 5 minutes. When fire is well established pull out damper 1/2".
- Wait 15 minutes, set fuel control and damper to desired setting.

NOTE: In the event of power failure shut stove "off", wait 15 seconds and repeat startup procedure.

3.4 PANEL CONTROLS

The blowers and automatic fuel supply (auger) are controlled from a panel on the left side of the stove. The ON-OFF-HIGH FAN switch turns the blowers on. The "AUGER" button activates the automatic feed system. When the green light is on, there is power to the auger circuit. The auger will not begin feeding pellets until the firebox has warmed up to a preset temperature. In case of a power outage lasting more than three to six seconds, this button must be pushed to re-engage the auger. There are four fuel feed settings. On "Low" the feed rate is approximately 0.75 to 1.5 lbs. per hour. On "B" feed rate is 2 to 2 1/2 lbs. per hour. On "C" feed rate is 3 to 3 1/2 lbs. per hour. On "High" the feed rate is approximately 4.5 to 5.3 lbs. per hour.

CAUTION: The "HIGH" setting is designed for temporary use only. If used for extended periods, it can shorten the life expectancy of the unit's components. Avoid use at this setting for more than one or two hours at a time.

The convection blower speed varies directly with feed rate. The "High Fan" switch overrides this variable speed function. It will set the convection blower speed to high at any feed rate setting.

The "MANUAL FEED" switch allows you to add fuel to the burn pot automatically. **CAUTION: Do not use this control during normal operation as it could smother the fire and lead to a dangerous condition** (see section 3.92 a). During normal operation, this switch will be off.

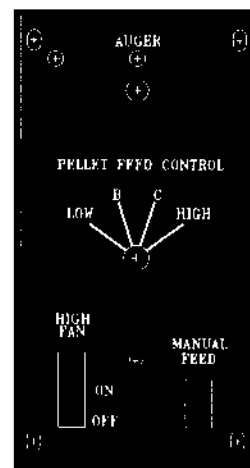

Figure 12

3.9 OPERATING SAFETY PRECAUTIONS

3.5 DAMPER CONTROL

The damper control rod on the stove's lower left side adjusts the combustion air. This control is necessary due to the varied burn characteristics of individual installations, different pellet brands and pellet feed rates. It allows you to improve the efficiency of your stove. Providing correct combustion air will reduce the frequency of cleaning your glass door and prevent the rapid build-up of creosote inside your stove and chimney.

You should adjust the damper based on the fire's appearance. A low, reddish, dirty fire can be improved by pulling the damper out slightly. A "blow torch" fire can be improved by pushing the damper in a bit.

As a general rule, on "LOW" the damper should be in farther. On higher feed rates, the damper should be more open. Through trial and error, you will find the best settings. Consult your dealer if you need help.

NOTE: On "LOW", damper should be out approximately 1/8"-1/4". If damper is out too far, it can cause the fire to go out.

3.6 REFUELING

We recommend that you not let the hopper drop below 1/4 full. **KEEP HOPPER LID CLOSED AT ALL TIMES EXCEPT WHEN REFILLING. DO NOT OVERFILL HOPPER.** Unlike liquids in a tank, pellets do not drain evenly into the auger. Bridging across the opening can occur. Pellets can hang up on the hopper sides. Occasional "stirring" the hopper can help.

NOTE: USE CARE WHEN CLOSING HOPPER DOOR TO AVOID INJURY TO FINGERS OR HAND.

3.7 SHUT DOWN PROCEDURE

Turning the Breckwell off is a matter of pressing the on/off control panel switch to off. The blowers will continue to operate until internal firebox temperatures have fallen to a preset level.

3.8 SAFETY FEATURES

- a. If there is a power outage longer than a few seconds, the auger will not operate once power is restored. This prevents pellets from being fed to a non-burning burn pot. Pressing the auger button on the panel control will reactivate the auger circuit. The blowers will come on when power is restored to evacuate the combustion chamber of gases and stay on until stove is switched off.
- b. In case of a malfunctioning convection blower, a high temperature thermodisk will shut down the auger, preventing the stove from overheating.
- c. If the combustion blower fails, an air pressure switch will shut down the auger.

a. If you notice a smoldering fire (burn pot full but no visible flame) **AND** a heavy smoke build-up in firebox, pull plug on unit. Do not open the door, change the damper setting, or tamper with any controls on stove. Wait 15 minutes or until firebox clears, open door, plug unit back in and restart fire as instructed in sections 3.2 and 3.3)

b. **DO NOT STORE OR USE FLAMMABLE LIQUIDS**, especially gasoline, in the vicinity of your Breckwell Stove. Never use a **gas or propane torch**, gasoline, gasoline-type lantern fuel, kerosene, charcoal lighter fluid or similar fluids to start or "freshen up" a fire in this heater.

c. **WARNING: DO NOT OVERFIRE THIS STOVE.** This may cause serious damage to your stove and void your warranty. It also may create a fire hazard in your home. Though extremely unlikely, **IF ANY EXTERNAL PART OF THE UNIT BEGINS TO GLOW, YOU ARE OVERFIRING.** Immediately press "off" switch on control panel.

d. **KEEP ALL HOUSEHOLD COMBUSTIBLES, SUCH AS FURNITURE, DRAPES, TOYS, ETC. A CONSIDERABLE DISTANCE FROM THE OPERATING STOVE.**

e. Maintain proper ventilation. It is important that adequate oxygen be supplied to the fire for the combustion process. Modern houses are often so well insulated, it may become necessary to open a window slightly or install an outside air vent to provide sufficient combustion air.

f. Since heating with a solid fuel fire is potentially hazardous, even with a well made and thoroughly tested stove, it would be wise to install strategically placed smoke detectors and have a fire extinguisher in a convenient location, near an exit.

g. Do not open stove door when operating unless necessary. This will create a dirty, inefficient burn and could allow smoke spillage or sparks to escape. Also, the auger will shut down.

h. Do not permit operation by young children or those unfamiliar with stove's operation.

i. **Do not service or clean this appliance without disconnecting power cord.**

j. Use only approved firestarters. These include gelled alcohol types and solid types with **wax** as an additive. **Do not use** solid types with paraffin, or liquids like barbecue lighter fluid, gasoline or rubbing alcohol. Do not use a **gas or propane torch** to light your stove.

4.0 MAINTENANCE

FAILURE TO CLEAN AND MAINTAIN THIS UNIT AS INDICATED CAN RESULT IN POOR PERFORMANCE AND SAFETY HAZARDS.

4.1 ASH DISPOSAL

Remove ashes periodically as they fill the firebox. To remove ashes:

- Make sure fire is out and firebox is cool.
- Remove imitation log set, if in use. Remove burn pot by grasping and pulling straight out.
- Empty ashes from burn pot into metal container. Scrape burn pot with cleaning tool.
- Use small shovel or vacuum to remove ashes (**WARNING: make sure ashes are cool to the touch before using a vacuum**).
- Replace burn pot. Make sure it is level and pushed all the way back in when it is reinstalled.

NOTE: Inspect burn pot periodically to see that holes have not become plugged. If so, clean thoroughly.

Ashes should be placed in a metal container with a tight fitting lid. The closed container of ashes should be placed on a non-combustible surface or on the ground, well away from all combustible materials pending final disposal. If ashes are disposed of by soil burial or otherwise locally disbursed, they should be retained in the closed container until all cinders have thoroughly cooled.

4.11 VACUUM USE

If a vacuum is used to clean your unit we recommend using a vacuum designed for ashes (Love-Less Ash Vac is one brand). Some regular vacuums and shop vacs leak ash into the room.

4.2 CLEANING

A. Heat Exchange Tubes — The Breckwell is designed with a built-in heat exchange tube cleaner. This should be used every two or three days to remove accumulated ash on the tubes, which reduces heat transfer. Insert the handle end (with hole) of cleaning tool on to cleaning rod. (see fig. 13) Move backwards and forwards several times. Leave tube cleaner at rear of stove.

B. Interior Chambers — Four (4) cover plates in the firebox can be removed for periodic cleaning (see figure 14). All four doors allow access to the chamber surrounding the firebox.

Periodically, you must vacuum ashes from this chamber. In some cases you will need to remove creosote which can accumulate rapidly under certain conditions. A small wire brush can be used. It is important to remove this creosote since it is highly combustible. **INSPECT BEHIND THESE COVER PLATES AT LEAST ONCE PER HALF TON OF PELLETS BURNED UNTIL YOU ARE FAMILIAR WITH HOW ASHES AND CREOSOTE ACCUMULATE WITH YOUR OPERATING PRACTICES.**

NOTE: Cover plate screws need to be snug only. Hand tight is normally sufficient.

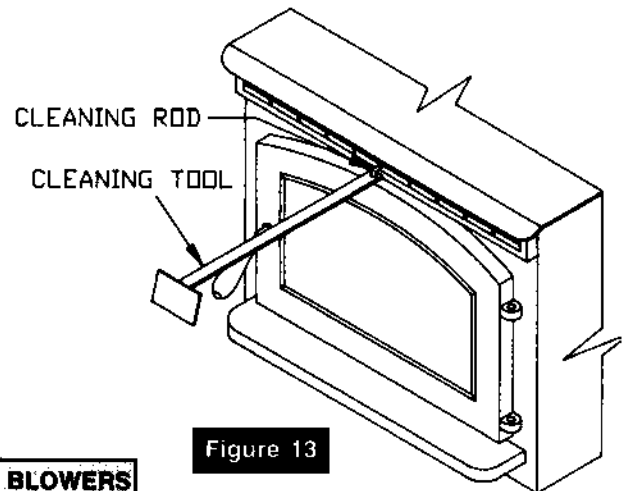

Figure 13

4.3 BLOWERS

- Cleaning** — Over a period of time, ashes or dust may collect on the blades of both the combustion blower and convection blower. Periodically the blowers should be vacuumed clean as these ashes can impede performance. Creosote can also accumulate in the combustion blower. This needs to be brushed clean. The convection blower is accessed by removing the stove's left side panel. The combustion blower is accessed through door C (see figure 14). The convection blower is on the left (facing stove), combustion blower on the right.

NOTE: Be careful when cleaning not to dislodge balancing clip on convection blower, or bend fan blades. Some stove owners lightly spray an anti-creosote chemical on the fire to help reduce creosote formation within the stove.

- Oiling** — Blower manufacturers suggest oiling annually. See figure 15 for lubrication points. Use SAE 20W motor oil. Limit to one or two drops.

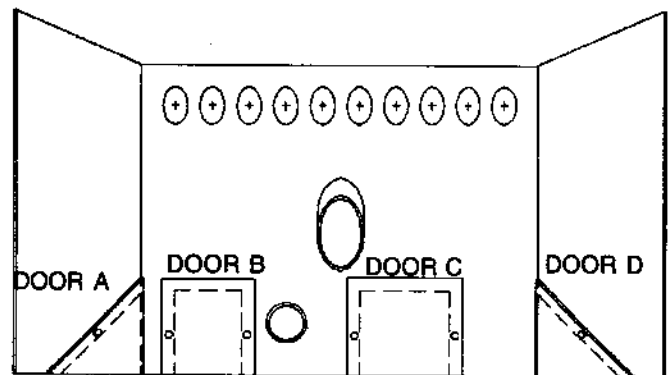

P-23

Figure 14

4.4 CHIMNEY CLEANING

- Creosote Formation** — When wood is burned slowly, it produces tar and other organic vapors which combine with expelled moisture to form creosote. The creosote vapors condense in the relatively cool chimney flue of a newly started fire or from a slow burning fire. As a result, creosote

residue accumulates on the flue lining. When ignited, this creosote makes an extremely hot fire which may damage the chimney or even destroy the house. Despite their high efficiency, pellet stoves can accumulate creosote under certain conditions.

b. **Fly Ash** — This accumulates in the horizontal portion of an exhaust run. Though noncombustible, it may impede the normal exhaust flow. It should therefore be periodically removed.

c. **Inspection and Removal** — The chimney connector and chimney should be inspected at least monthly during the heating season to determine if a creosote or fly ash buildup has occurred.

If creosote has accumulated, it should be removed to reduce the risk of a chimney fire. Inspect the system at the stove connection and at the chimney top. Cooler surfaces tend to build creosote deposits quicker, so it is important to check the chimney from the top as well as from the bottom.

The creosote should be removed with a brush specifically designed for the type of chimney in use. A qualified chimney sweep can perform this service. It is also recommended that before each heating season the entire system be professionally inspected, cleaned, and repaired if necessary.

To clean the chimney, you can detach the vent at the combustion blower transition. Make sure you reattach and seal chimney connection.

4.5 RECOMMENDED MAINTENANCE SCHEDULE

Use this as a guide under average use conditions.

	Daily	Twice Weekly	Monthly or per 1/2 ton	Annually
Burn pot	stirred	emptied		
Clean Glass	wiped			
Combustion Chamber		brushed		
Firebox		emptied		
Exhaust Passage			vacuumed	
Heat Exchange Tubes		two passes		
Combustion Blower Blades			vacuumed brushed	
Fan Motors				oiled
Vent System				cleaned
Gaskets				inspected

Gasket around door and door glass should be inspected and repaired or replaced when necessary (see section 6.0).

5.0 TROUBLE-SHOOTING GUIDE

When your stove acts out of the ordinary, the first reaction is to call for help. This guide may save time and money by enabling you to solve simple problems yourself. Problems can be due to only five factors: 1) poor fuel; 2) poor operation or maintenance; 3) poor installation; 4) component failure; 5) factory defect. You can usually solve those related to 1 and 2. Your dealer can solve those in 3, 4 and 5. Refer to figures 15 and 16 to help locate indicated parts.

REMEMBER: Pull plug before servicing, unless otherwise instructed.

5.1 FUEL WILL NOT FEED

1. Check for fuel in hopper. If stove runs out of fuel, pellets will not feed once hopper is reloaded until auger fills with pellets. This takes several full turns of the auger. Hold manual feed switch on for four minutes.

2. Push "auger" button. Green light should come on.

3. Check for auger jam. Push the manual feed switch. If you can hear the auger motor trying to run but no pellets fall into burn pot you may have a jammed auger. Contact your dealer.

4. If auger motor is not working, and there is power to the system (green light is on) the auger thermodisk may be stuck in open position. Check the thermodisk with continuity tester. Auger thermodisk closes with heat rise. If problem persists, call dealer.

5. If vacuum in the stove is lost, an air switch shuts off the auger. Inspect for source of lost vacuum. Faulty door seal will cause this.

6. If a stove set at "HIGH" is suddenly switched to "LOW", a temporary overheat condition may occur. This condition may stop the auger and cause the green light to go off. Press the "OFF" switch and the "HIGH FAN" switch. Allow stove to cool down and restart as instructed in sections 3.2 and 3.3.

5.2 FIRE GOES OUT

(assuming auger is feeding and there is ample fuel in hopper and burn pot)

1. Check for blockage in combustion air inlet, burn pot and exhaust.

2. Large pellets feed more slowly. It is sometimes difficult to maintain a fire on low. If this problem recurs, call your dealer.

3. Check to see if combustion blower is operating.

4. Damper may be out too far.

5.3 SMOKY FIRE (see section 3.6 first)

(reddish flame, soot deposits on door glass)

1. Check door and door glass gasket. Door should be tightly sealed. Replace gasket if necessary.

2. Check that burn pot is installed properly and holes are not plugged.

3. Check for blockage in combustion air inlet, burn pot and exhaust.

4. Check quality of fuel (see section 3.1).

5. Adjust slide damper (see section 3.6).

5.4 NO POWER

1. Check power supply to stove.

5.5 BLOWERS WILL NOT OPERATE PROPERLY

1. Check power supply.

2. Check blower thermodisk with continuity tester. Blower thermodisk closes with heat rise.

3. Check combustion blower for creosote or ash buildup.

5.6 NOISY OPERATION

1. Identify source of noise (i.e. which motor)

2. Adjust tension of blower mounting screws if vibrating noise.

3. Check for dirty or unbalanced impeller wheel on blowers if clanging noise.

4. Oil convection blower with SAE 20W motor oil. (1-2 drops only)

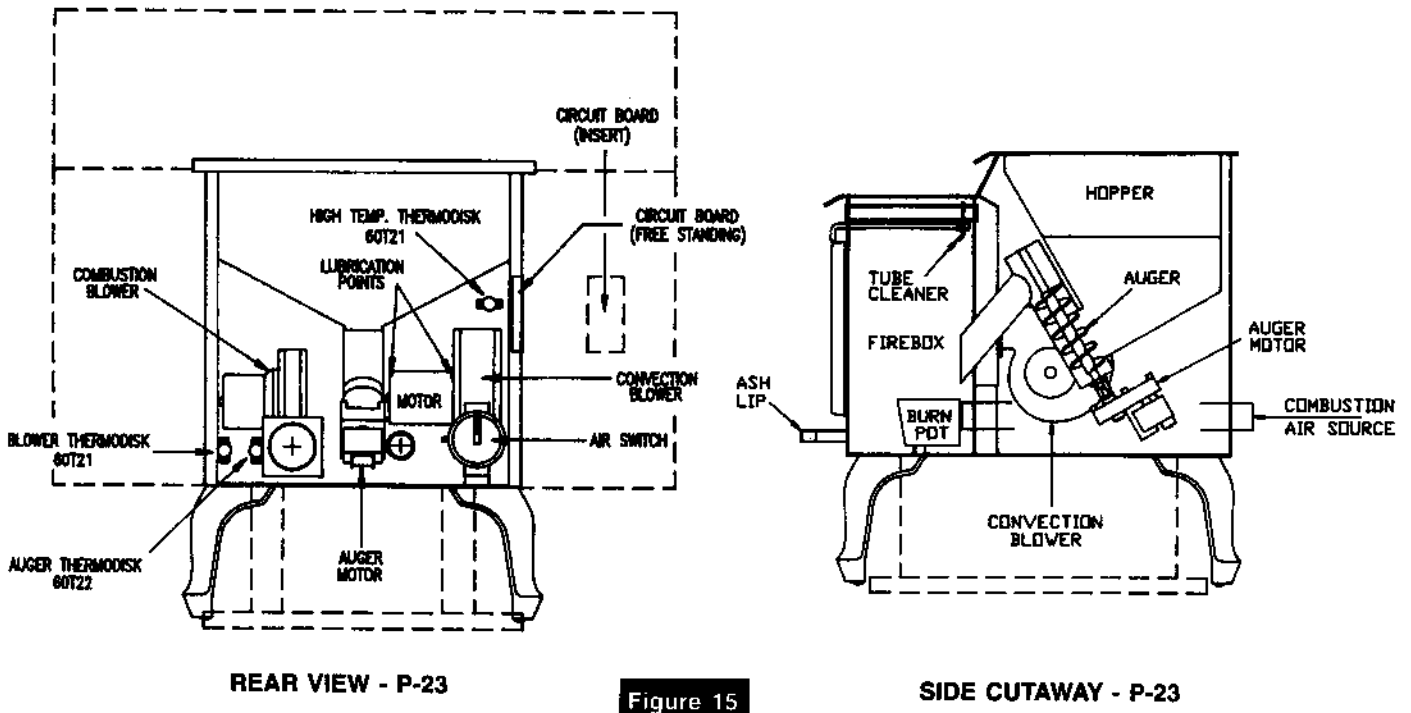

6.0 REPLACEMENT PARTS

Contact an Authorized Breckwell Pellet Stove Dealer to obtain any of these parts

Item

- Spring Door Handle
- Black Knob (damper)
- Door Glass
- Window Clips
- Door Gasket (five feet)
- Window Gasket (five feet)
- Circuit Board/Control Panel
- Convection Blower (P23)
- Combustion Blower
- Auger Gear Motor (1 RPM)
- High Temp Thermodisk (T21)
- Auger/Blower Thermodisk (T22)
- Burn Pot
- Cleaning Tool
- Furnace Cement (2-Oz.)
- Air Switch

Optional Items for Your P23

- Imitation Firelog Set
- Extended Flashing Set
- Zero Clearance Skirt
- Hot Rod™ Automatic Firestarter (A-HR)

