

4x4 FRONT AXLE ENGAGEMENT

TROUBLESHOOTING GUIDE



**DIAGNOSIS AND REPAIR OF PROBLEMATIC
FRONT AXLE ENGAGEMENT SYSTEMS**

CHEVROLET/GMC • DODGE • JEEP

4x4 Posi-Lok

POSITIVE AXLE ENGAGEMENT

Technical Assistance
517-278-7453
Sales Representative
517-279-7177
www.4x4posi-lok.com

Use this definitive 4-wheel drive front axle engagement guide to understand, diagnose, and repair those mysterious 4-wheel drive front axle issues. This guide explains how the OEM units function, what causes them to fail, and which corrections are available.

WHAT IS 4X4 POSI-LOK?

4x4 Posi-Lok is the patented cable activated engagement device designed to replace the failure prone vacuum and electric front axle engagement systems. *4x4 Posi-Lok is not a posi-trac or locker.* 4x4 Posi-Lok is simple and easy to install and allows you to engage your front axle from inside the cab. Posi-Lok guarantees that your 4-wheel drive will engage every time because you are in direct control of front axle engagement. A one inch pull of the 4x4 Posi-Lok cable ensures you will have 4-wheel drive when you need it, as long as the transfer case is engaged.

POSI-LOK BENEFITS

- 4x4 Posi-Lok provides 2-wheel drive low range, giving the vehicle 4-LO torque at the rear axles with bind free steering only available in 2-HI. This feature is not available with factory systems and is beneficial when maneuvering trailers.
- 4x4 Posi-Lok reduces front differential wear and right axle breakage.
- 4x4 Posi-Lok will not disengage when the ignition is turned off or the differential is submerged.
- 4x4 Posi-Lok is compatible with manual or electric transfer cases and complete installation can be completed in one to two hours with basic hand tools. No internal differential work required.

HOW 4X4 POSI-LOK BEGAN

4x4 Posi-Lok [Patent No. 5,605,213] was invented by Dick White in the early 1990's. Prompted by multiple failures on his own late model Chevy 4-wheel drive, White realized that the TLA (Thermal Linear Actuator) wasn't engaging the right front wheel even when the transfer case was in 4-LO and the 4-wheel drive dash light was on.

After careful study and design, White invented a cable operated actuator to replace the failing TLA. The new system functioned flawlessly, and provided a benefit that the factory design could never provide: 2-wheel drive low range.

White went on to develop a Posi-Lok system for the vacuum actuated Chevrolet/GMC T-10/15 Sonoma Pickup, Blazer and Jimmy, Dodge Ram Pickup and Jeep Wrangler YJ, Cherokee XJ and Comanche MJ.

TESTIMONIALS

"The 'throw' or 'pull' of this device is minimal at one-inch or less, and once you get the feel of it, shifting on the fly is easy, as is locking or unlocking the front axle engagement from a stop. This is an aftermarket accessory that makes sense for everybody."

—Paul Hantke; *ModernSurvival.net*

"Thankfully, there are some ingenious people left in the world who've devised systems that positively engage the front axle [4x4 Posi-Lok]."

—Rick Péwé; *4-Wheel and Off-Road Magazine*

"[4x4 Posi-Lok] puts the control of four wheel drive back into the hands of the driver where it should be."

—Albert Vandervelde; *Canadian 4-Wheel Drive*

APPLICATIONS

1988-1998 Pickup
1992-1998 Suburban
1992-1998 Tahoe and Yukon

Note: With Thermal Linear Actuator (TLA)



SECTION 1

SLOW ENGAGEMENT OF FRONT AXLE

Owners of Chevrolet/GMC vehicles will comment that the colder the temperature, the longer it takes for the front axle to engage.

Function

The front axle actuator is a temperature controlled plunger. It is located on the passenger side (right) axle tube. The solenoid threads into the differential [Fig. 1]. After engaging the transfer case, electrical current heats the solenoid plunger [Fig. 2], which extends approximately one (1) inch. The solenoid plunger slides the shift fork and collar, connecting the freewheeling right front axle to the driven left front axle [Fig. 3].

Cause

- Temperatures below 30 degrees Fahrenheit causes engagement to take up to 30 seconds. Per GM Service Bulletin #76-43-01 dated April 1997, engagement of up to 30 seconds is within the design parameters.
- Defective TLA.

Correction

1. Replace the TLA with one of the following:
 - OEM P/N 26013495
2. Or Install 4x4 Posi-Lok
 - P/N PSL 600 or PSL 800 (See App. Guide)

SECTION 2

NO ENGAGEMENT

Cause

If the 4-wheel drive will not engage, one of the following may be the cause: a defective TLA, spline and axle damage, or wiring issues with the transfer switch.

Correction

1. Remove TLA. Insert six (6) inch dowel rod and push the fork until it stops. Check for free movement of the fork and shift collar [Fig. 3]. (To ensure spline alignment, slight rotation of one axle may be necessary.) If the shift fork and collar slide freely, reinstall the TLA and see step 2. If the shift fork and collar do not slide freely, there may be internal differential damage due to incomplete actuator engagement. Major differential service is required and must be repaired before proceeding.
2. Check for electrical current to the TLA using a test light. If present, remove TLA [Fig. 2]. Replace the TLA with one of the following:
 - OEM P/N 26013495 (first series)
 - Or Install 4x4 Posi-Lok P/N PSL 600 or P/N PSL 800 (See App. Guide)

FIGURE 1

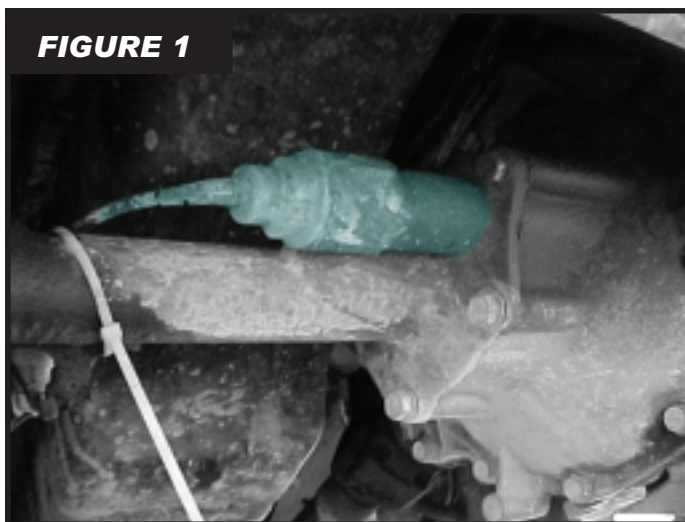
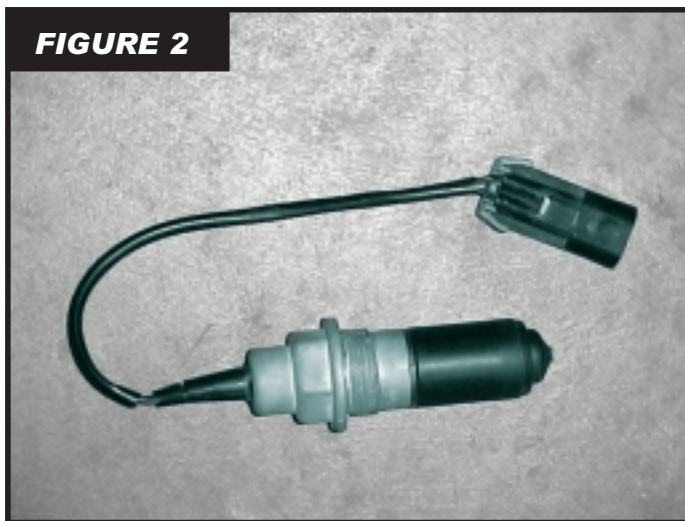

FIGURE 2



K SERIES



Note: If electrical current is not present, check wiring continuity and transfer case switch. See service manual for details.

SECTION 3 DISENGAGEMENT WHILE IN 4-WHEEL DRIVE

Cause

- If front differential is submerged in snow or water, the TLA unit will cool and allow disengagement.
- If the ignition is turned off, the TLA unit will disengage due to no electrical current. Upon restarting, the TLA unit may take up to 30 seconds to engage.

Correction

The only solution is to install 4x4 Posi-Lok P/N PSL 600 or P/N PSL 800 (See App. Guide.) The 4x4 Posi-Lok is a cable operated system not affected by cold weather or lack of electrical current. [Fig. 3]

FIGURE 3

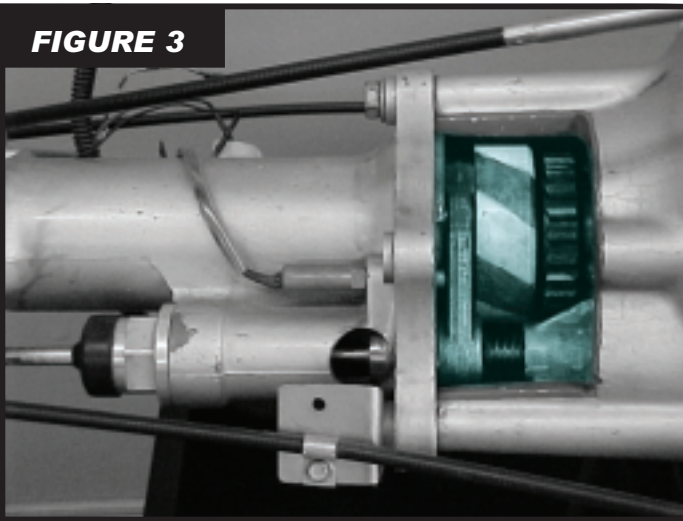

ALSO AVAILABLE: PERM LOK

4x4 Posi-Lok P/N PSL 1000 (See App. Guide)

The Perm Lok permanently engages the Central Axle Disconnect (CAD) system and couples both front axles. Once installed, the front axles will not pull until the transfer case is engaged. This application is ideal for fleet operators or emergency vehicles. Installation is easy and can be completed in approximately 10 minutes.

HOW 4X4 POSI-LOK WORKS

The failure prone thermal linear actuator is replaced with the cable operated 4x4 Posi-Lok system [Fig. 4]. The thermal linear actuator is replaced with a cable actuated rod. The cable's T-handle is conveniently routed under the dash. Placing the vehicle's transfer case in 4-wheel drive and pulling the Posi-Lok cable handle slides the shift fork and collar to connect the freewheeling right axle to the driven left axle. Both front wheels are now engaged and pulling the vehicle. 4x4 Posi-Lok can be easily installed in one to two hours with basic hand tools.

FIGURE 4

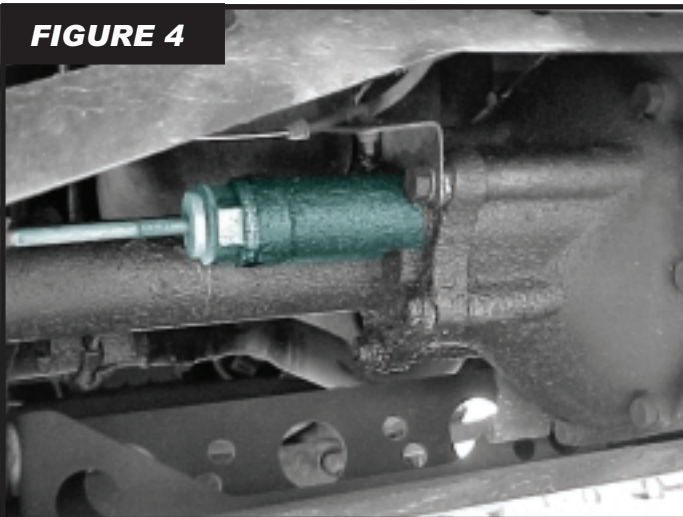

DID YOU KNOW: Posi-Lok will not disengage when the engine is turned off or front differential is submerged.

CHEVROLET/GMC T SERIES

APPLICATIONS

1983-01 T-10/15 Sonoma Pickup, Blazer & Jimmy (Including ZR2 and Highrider)
Note: S-10/15 series is 2-wheel drive

4x4 Posi-Lok
POSITIVE AXLE ENGAGEMENT

SECTION 1

SLOW TO NO ENGAGEMENT

Many T-Series owners comment that their 4-wheel drive is slow to or does not engage when the transfer case is shifted into 4-wheel drive.

Function

The OEM front axle actuator is a vacuum controlled cable system. Placing the vehicle in 4-wheel drive causes the vacuum port to activate the diaphragm plunger [Fig 1]. The diaphragm plunger pulls the cable attached to the shift fork in the front differential [Fig. 2]. This connects the freewheeling passenger side (right) front axle to the driven (left) front axle.

Cause

The vacuum unit may have a frozen diaphragm, a damaged OEM cable, or damaged vacuum lines.

Correction

1. Start the engine. Check for presence of vacuum at the intake manifold port that supplies vacuum to the actuator diaphragm. If vacuum is present with the engine running, proceed to step 2. If vacuum is not present, there are mechanical problems that need to be addressed before continuing.
2. Check for presence of vacuum at diaphragm located either under or beside the battery [Fig. 1]. A simple method to locate the diaphragm is to follow the cable from the front differential to inside the passenger side engine compartment. If vacuum is present proceed to step 4. If vacuum is not present proceed to step 3.
3. Check for hard, cracked or missing vacuum lines. Replace vacuum lines as needed. Start engine and place transfer case in 4-wheel drive. Check for vacuum at actuator diaphragm. If the passenger (right) axle still does not engage, proceed to step 4 and 5.
4. Check the diaphragm on the vacuum actuator. If it appears to be frozen or not working correctly, replace with one of the following:
 - OEM unit P/N 25031740
 - Or install 4x4 Posi-Lok P/N PSL 500 (See App. Guide)



FIGURE 1

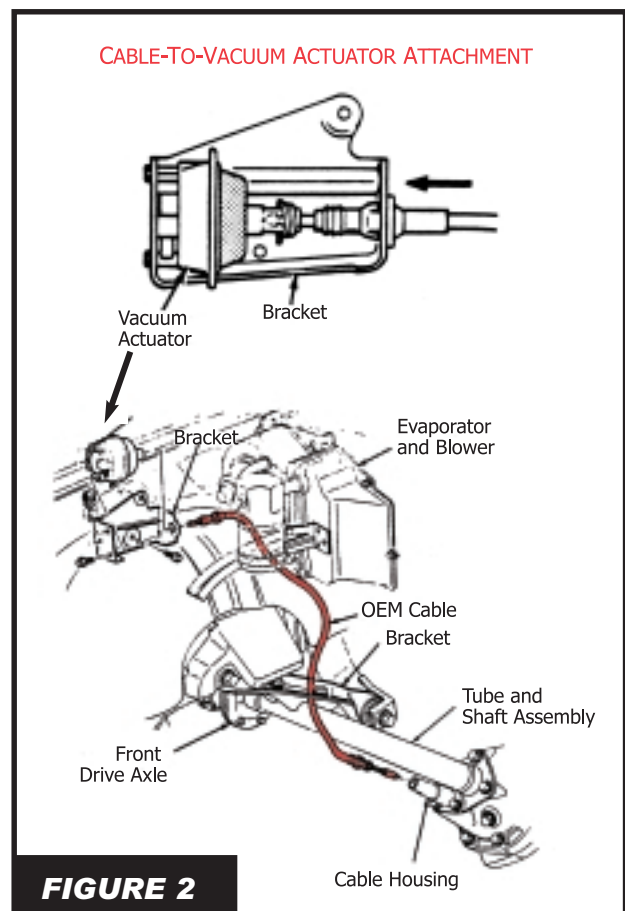

FIGURE 2

T SERIES



If the diaphragm appears to be working correctly, proceed to step 5.

5. Check cable going from the vacuum diaphragm to the front axle for damage [Fig. 2]. Disconnect cable at differential and diaphragm and pull the diaphragm end of the cable approximately one (1) inch. If there is any resistance, replace the cable with OEM P/N 15654073. See service manual for cable replacement. If cable moves freely, you may have internal differential damage due to incomplete actuator engagement. This will require major differential service and must be repaired before proceeding.

Note: *If the OEM cable is damaged, you will need to replace it whether you use an OEM replacement diaphragm, or the Posi-Lok PSL 500.*

SECTION 2 FRONT AXLE DISENGAGEMENT WHILE IN 4-WHEEL DRIVE

Cause

This condition may be caused by a corroded transfer case switch.

Correction

1. Replace with a switch constructed of noncorrosive stainless steel, OEM P/N 15664811.
2. Check for oil leaks at the threads and vacuum leaks in the lines.

SECTION 3 DIFFICULT TRANSFER CASE SHIFT

Some 1988-91 Pickups may experience difficulty in transfer case shifting or totally blocked when “shifting on the fly” from 2-HI to 4-HI in cold weather conditions.

Correction

1. Install synthetic 75W90 gear lube. This fluid maintains a more constant viscosity under cold weather, allowing quicker front axle engagement.
2. If the installation of synthetic lube does not result in a satisfactory shift, an “Easy Shift” package can be installed in the transfer case. This package features a roller pin, rather than a solid pin in the shift fork.

Note: *The 4x4 Posi-Lok will not solve hard to engage transfer case problems. It is designed to eliminate front axle engagement/disengagement issues.*

HOW 4X4 POSI-LOK WORKS

The failure prone vacuum actuator is replaced with the cable operated 4x4 Posi-Lok system. The vacuum diaphragm is removed from the OEM cable and the 4x4 Posi-Lok assembly attached and routed to a convenient location under the dash. Engaging the transfer case and pulling the Posi-Lok T-handle will slide the shift fork and collar to connect the freewheeling right axle to the driven left axle. Both front wheels are now engaged and pulling the vehicle. 4x4 Posi-Lok can be easily installed in one to two hours with basic hand tools [Fig. 3].

DID YOU KNOW: Posi-Lok works like hubs from inside the cab.

FIGURE 3

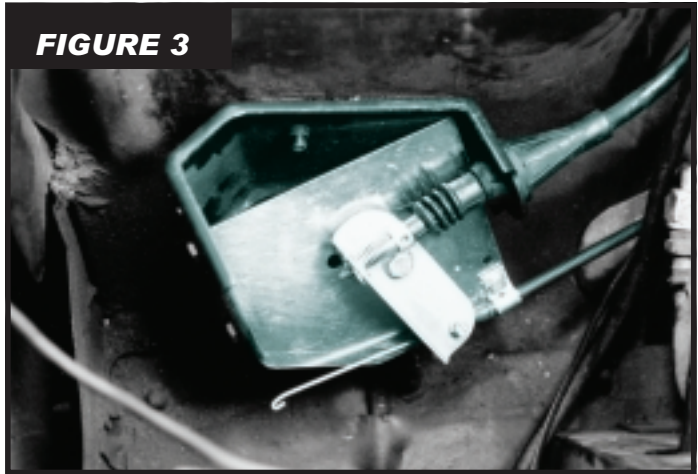

APPLICATIONS

1994-2001 Ram 1500-3500 w/ Dana 44-60

Note: Central Axle Disconnect (CAD)



SECTION 1

SLOW TO NO ENGAGEMENT FOR GASOLINE ENGINES

Many Dodge owners comment that their 4-wheel drive is slow to or does not engage when the transfer case is shifted into 4-wheel drive.

Function

The OEM front axle actuator is vacuum controlled. When the transfer case is placed in 4-wheel drive, the vacuum plunger activates and pushes the shift fork, sliding the collar and coupling the freewheeling passenger side (right) axle to the driven intermediate axle.

Cause

The vacuum system does not always supply enough vacuum to engage the axles. If the vacuum actuator is malfunctioning, possible axle spline, shift fork, or collar damage has occurred. See section 3.

Correction

1. Start the engine. Check for presence of vacuum at the intake manifold port that supplies vacuum to the actuator diaphragm. If vacuum is present with the engine running, proceed to step 2. If vacuum is not present, there are mechanical problems that need to be addressed before continuing.
2. Check for presence of vacuum at actuator diaphragm located on the passenger (right) side of the front axle tube [Fig. 1]. If vacuum is present proceed to step 4. If vacuum is not present proceed to step 3.
3. Check for hard, cracked or missing vacuum lines. Replace vacuum lines as needed. Start engine and place transfer case in 4-wheel drive. Check for vacuum at actuator diaphragm. If the passenger side (right) axle still does not engage, proceed to step 4.
4. Check the diaphragm on the vacuum actuator. If it appears to be frozen or not working correctly, replace with one of the following:
 - OEM unit P/N 4882682
 - Or install 4x4 Posi-Lok P/N PSL 400 (See App. Guide)

SECTION 2

SLOW TO NO ENGAGEMENT FOR DIESEL ENGINES

Cause

The diesel engine does not produce vacuum. Therefore, it must rely on a vacuum pump as the vacuum source for power brake boosters, heater, AC control operation and front axle actuator.

Correction

1. Start the engine. Check for presence of vacuum at vacuum pump located on the drivers side front of the engine. If vacuum is present with the engine running, proceed to step 2. If vacuum is not present, there are mechanical problems that need to be addressed before continuing.

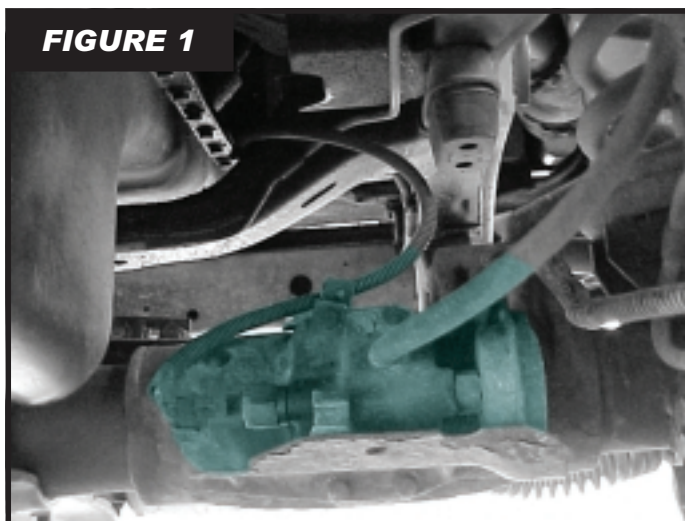

FIGURE 1

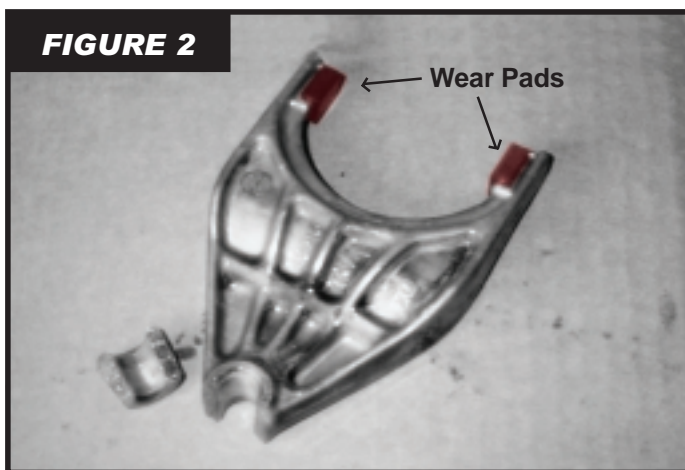

FIGURE 2

RAM



2. Check for presence of vacuum at actuator diaphragm on the axle tube. If the vacuum is present, proceed to step 4. If vacuum is not present, proceed to step 3.
3. Check for hard, cracked or missing vacuum lines. Replace vacuum lines as needed. Start engine and place transfer case in 4-wheel drive. Check for vacuum at actuator diaphragm. If the passenger side (right) axle still does not engage, proceed to step 4.
4. Check the diaphragm on the vacuum actuator. If it appears to be frozen or not working correctly, replace with one of the following:
 - OEM unit P/N 25031740
 - **Or install 4x4 Posi-Lok P/N PSL 400 (See App. Guide)**

SECTION 3

POSSIBLE AXLE DAMAGE

1. Unbolt the actuator housing from the axle tube by removing the four (4) bolts [Fig. 1]. Inspect the fork for damage or wear [Fig. 2]. If there is excessive clearance between the fork and the actuator shaft, it should be replaced with OEM P/N 4137727. Inspect the wear pads on the tips of the fork for wear [Fig 2]. If they are worn, replace them with OEM P/N 4137731.
2. Slide the collar side to side over the axle splines to confirm free movement [Fig 3]. (You may have to rotate one axle slightly for spline alignment.) If it does not slide freely, it is possible that there is damage or burrs on the collar and/or axles. The collar can be replaced with OEM P/N 4778548. Axle part numbers will vary based on the year and GVW of the vehicle.

Note: *If a failing actuator has caused spline damage, the axle(s) and shift collar must be replaced before the new actuator or 4x4 Posi-Lok is installed.*

SECTION 4

PARTIAL ENGAGEMENT OR DISENGAGEMENT

Lack of vacuum, failing diaphragm, failing actuator (see section 1 or 2), and/or burred axle splines or shift collar (see section 3), may be factors in partial engagement or disengagement.

FIGURE 3

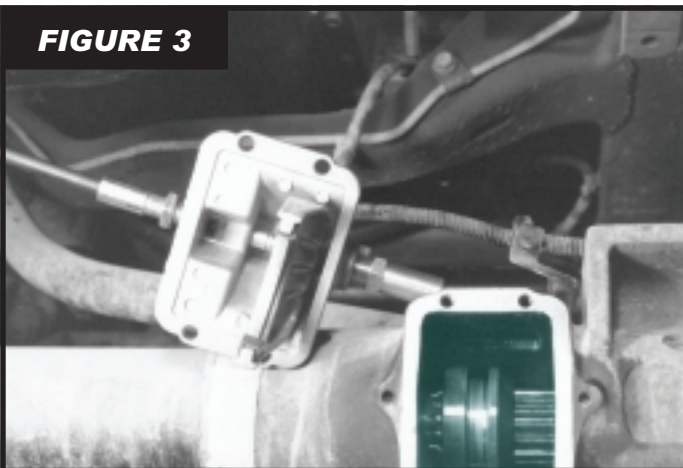

HOW 4X4 POSI-LOK WORKS

The failure prone vacuum actuator is replaced with the cable operated 4x4 Posi-Lok system. The vacuum actuator is removed from the axle tube and the 4x4 Posi-Lok assembly is attached and the cable routed to a convenient location under the dash. Engaging the transfer case and pulling the Posi-Lok T-handle will slide the shift fork and collar to connect the freewheeling right axle to the driven intermediate axle. Both front wheels are now engaged and pulling the vehicle. 4x4 Posi-Lok can be easily installed in one to two hours with basic hand tools.

DID YOU KNOW: Posi-Lok will give you 2-wheel drive low range.

JEEP MJ, XJ, YJ

APPLICATIONS

1987-1995 Wrangler YJ

1984-1991 Cherokee XJ

1986-1991 Comanche MJ

Note: With Dana 30 Central Axle Disconnect (CAD)



SECTION 1

SLOW TO NO ENGAGEMENT

Many Jeep owners comment that their 4-wheel drive is slow to or does not engage when the transfer case is shifted into 4-wheel drive.

Function

The OEM front axle actuator is vacuum controlled. When the transfer case is placed in 4-wheel drive, the vacuum plunger activates and pushes the shift fork, sliding the collar and coupling the freewheeling passenger side (right) axle to the driven intermediate axle.

Cause

The vacuum system at times does not produce enough vacuum to engage the freewheeling right front axle to the driven intermediate axle. If the vacuum actuator is malfunctioning, possible axle spline, shift fork, or collar damage has occurred. See section 3.

Correction

1. Start the engine. Check for presence of vacuum at the intake manifold port that supplies vacuum to the actuator diaphragm. If vacuum is present with the engine running, proceed to step 2. If vacuum is not present, there are mechanical problems that need to be addressed before continuing.
2. Check for presence of vacuum at actuator diaphragm located on the axle tube [Fig. 1]. The vacuum actuator is located on the passenger side (right) of the front axle tube. If vacuum is present proceed to step 4. If vacuum is not present proceed to step 3.
3. Check for hard, cracked or missing vacuum lines. Replace vacuum lines as needed. Start engine and place transfer case in 4-wheel drive. Check for vacuum at actuator diaphragm. If the passenger (right) axle still does not engage, proceed to step 4.
4. Check the diaphragm on the vacuum actuator. If it appears to be frozen or not working correctly, replace with one of the following:
 - OEM Vacuum Actuator P/N 8353113
 - **OR 4x4 Posi-Lok** P/N PSL 900 (See App. Guide)

Note: Before replacing the vacuum actuator, check the shift fork for damage. See section 3-1.

SECTION 2

PARTIAL ENGAGEMENT OR DISENGAGEMENT

Lack of vacuum, failing diaphragm or actuator (see section 1), worn or broken fork [Fig. 2], or burred axle splines or shift collar (see section 3), may be

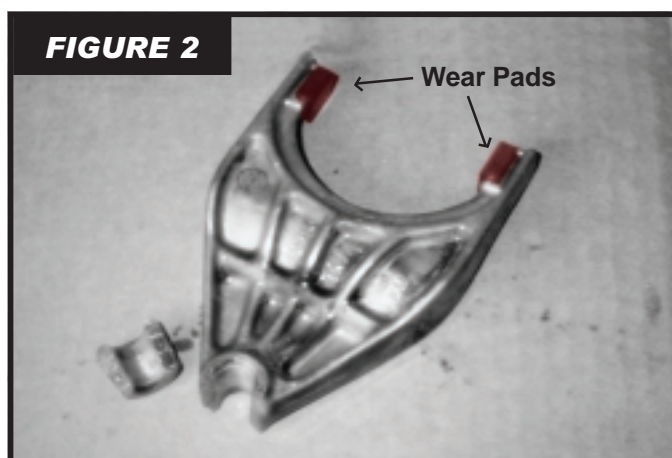
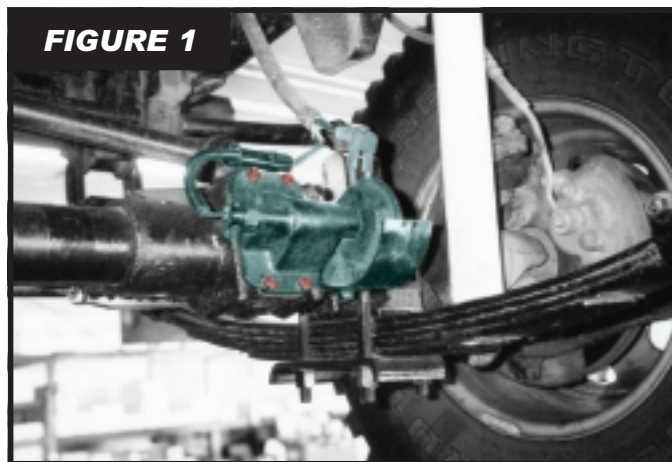

MJ, XJ, YJ



factors in partial engagement or disengagement.

SECTION 3 POSSIBLE AXLE DAMAGE

1. Unbolt the actuator housing from the axle tube by removing the four (4) bolts [Fig. 1]. Inspect the fork for damage or wear [Fig. 2]. If there is excessive clearance between the fork and the actuator shaft, the fork should be replaced with OEM P/N 5252599. Inspect the wear pads on the tips of the fork for wear [Fig. 2]. If the pads are worn, replace them with OEM P/N 4137731.

Note: 4x4 Posi-Lok strongly recommends replacement of the aluminum fork with a cast iron fork P/N 4137727.

2. Slide the collar side to side over the axle splines to confirm free movement [Fig. 3]. (You may have to rotate one axle slightly for spline alignment.) If it does not slide freely, it is possible that there is damage or burrs on the collar and/or axles. The collar can be replaced with OEM P/N 4778548. For axle part numbers, contact your local Jeep dealer.

Note: If a failing actuator has caused spline damage, the axle(s) and shift collar must be replaced before the new actuator or 4x4 Posi-Lok is installed.

FIGURE 3

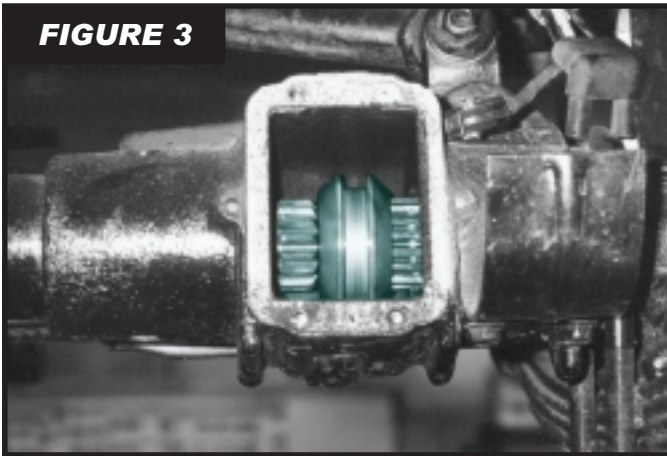

HOW 4X4 POSI-LOK WORKS

The failure prone vacuum actuator is replaced with the cable operated 4x4 Posi-Lok system. The vacuum actuator is removed from the axle tube and the 4x4 Posi-Lok assembly is attached and the cable routed to a convenient location under the dash. Engaging the transfer case and pulling the Posi-Lok T-handle will slide the shift fork and collar to connect the freewheeling right axle to the driven intermediate axle [Fig. 4]. Both front wheels are now engaged and pulling the vehicle. 4x4 Posi-Lok can be easily installed in one to two hours with basic hand tools [Fig. 5].

FIGURE 4

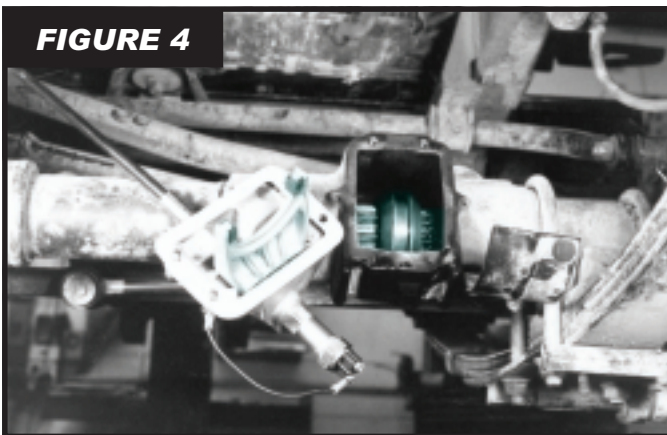
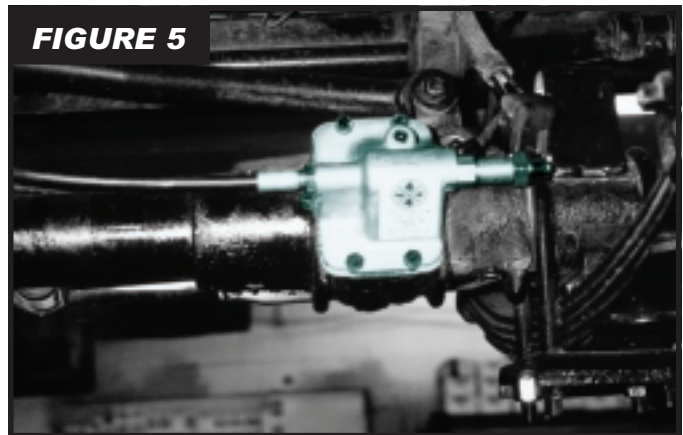

FIGURE 5



LIMITED WARRANTY

4x4 Posi-Lok company warrants to the original retail purchaser that the 4x4 Posi-Lok is free from defects in material and/or workmanship for one (1) year from the purchase date when used under normal operating conditions on light trucks and SUV's. The warranty does not apply to 4x4 Posi-Lok Products that have been improperly applied or installed. The consumer will be responsible for removing from the vehicle and returning to 4x4 Posi-Lok and defective item(s) with shipping costs prepaid. A copy of the original sales receipt is required for all warranty claims. The consumer may contact 4x4 Posi-Lok at (517) 278-7453 in order to receive a Returned Goods Authorization prior to shipping. Ship the item, freight prepaid, to: 4x4 Posi-Lok, 404 Jay Street, Coldwater, MI 49036, along with a copy of your sales receipt. 4x4 Posi-Lok will, without charge, repair or replace at its option, the defective item(s). The item will be returned with transportation costs prepaid within the U.S.

LIMITATION OF WARRANTIES

The loss of use of the product or vehicle, loss of time, inconvenience, commercial loss or consequential damages are not covered. 4x4 Posi-Lok reserves the right to change the design of any product without assuming any obligation to modify any product previously manufactured.

This warranty gives you specific legal rights and you may also have other rights which may vary from state to state. Some states do not allow limitations on how long an implied warranty lasts or allows the exclusion or limitation of incidental or consequential damages, the above limitation or exclusion may not apply to you.

There are no warranties, expressed or implied, including any implied warranties of merchantability and fitness, which extend beyond the face hereof. Seller disclaimers implied warranty of merchantability.

LIMITATION OF LIABILITY

4x4 Posi-Lok's liability hereunder shall not exceed the purchase price of the product. 4x4 Posi-Lok shall not be liable for any incidental or consequential damages, whether direct or indirect, including, but not limited to, personal injury, property damage, economic loss, loss of profit, or the like. 4x4 Posi-Lok shall not be liable for any damages or defects of any kind whatsoever after installation of the 4x4 Posi-Lok, unless the purchaser has complied with any and all installation instructions. The limitation of liability as set forth above shall apply even to claims of negligence or strict liability against 4x4 Posi-Lok.



104 S. Michican Ave.
Coldwater, MI 49036
Fax: 517-278-2316

Technical Assistance: 517-278-7453

Sales: 517-279-7177

www.4x4posi-lok.com

Every effort has been made to avoid printing errors in this catalog. However, in the event of an error, 4x4 Posi-Lok must disclaim any responsibility.