

CAUTION!

PLEASE SWITCH POWER OFF
BEFORE SERVICING UNIT

Commercial Freezer

Service Manual

SOLID DOOR REACH-IN

P49F



Please read this manual completely before attempting to install or operate this equipment

TABLE OF CONTENTS

1. FEATURE CHART

1-1. OUTSIDE DRAWING AND MEASUREMENT FOR P49F

2. WIRING DIAGRAM

2-1. FREEZER (2 DOORS): P49F

3. PARTS DETAILS

3-1. FRONT PANEL

3-2. REFRIGERATION COMPARTMENT

3-3. DOOR

3-4. COOLING COMPARTMENT

4. MAIN COMPONENTS

4-1. COMPRESSOR

4-2. COMPRESSOR RELAY

4-3. CONDENSER DRYER

4-4. CAPACITOR

4-5. EVAPORATOR FAN MOTOR

4-6. CONDENSER FAN MOTOR

4-7. EVAPORATOR DEFROST HEATER

4-8. LAMP

4-9. THERMOSTAT

5. ELECTRONIC CONTROLLER INSTRUCTION

5-1. REFRIGERATOR CONTROLLER

5-1-1. DIXELL XR60C PARAMETER FOR FREEZER P49F

5-1-2. HOW TO USE THE CONTROLLER

6. REPLACEMENT OF MAIN COMPONENTS

6-1. BOTTOM PANEL PARTS

6-2. REFRIGERATION COMPARTMENT PARTS

6-3. CONDENSING UNIT

1. FEATURE CHART

1-1. OUTSIDE DRAWING OF P49F

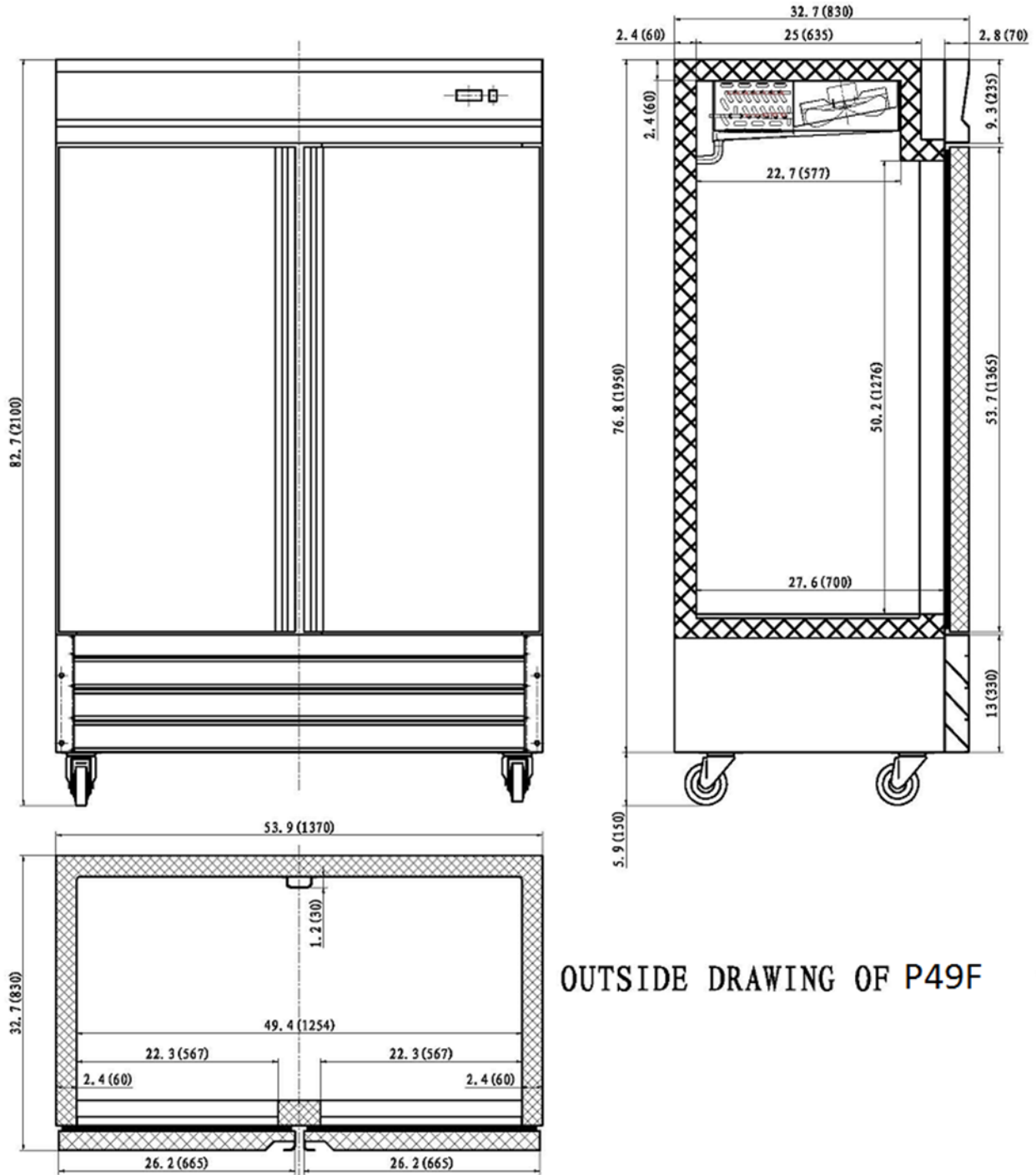

OUTSIDE DRAWING OF P49F

2. WIRING DIAGRAM

2-1. P49F

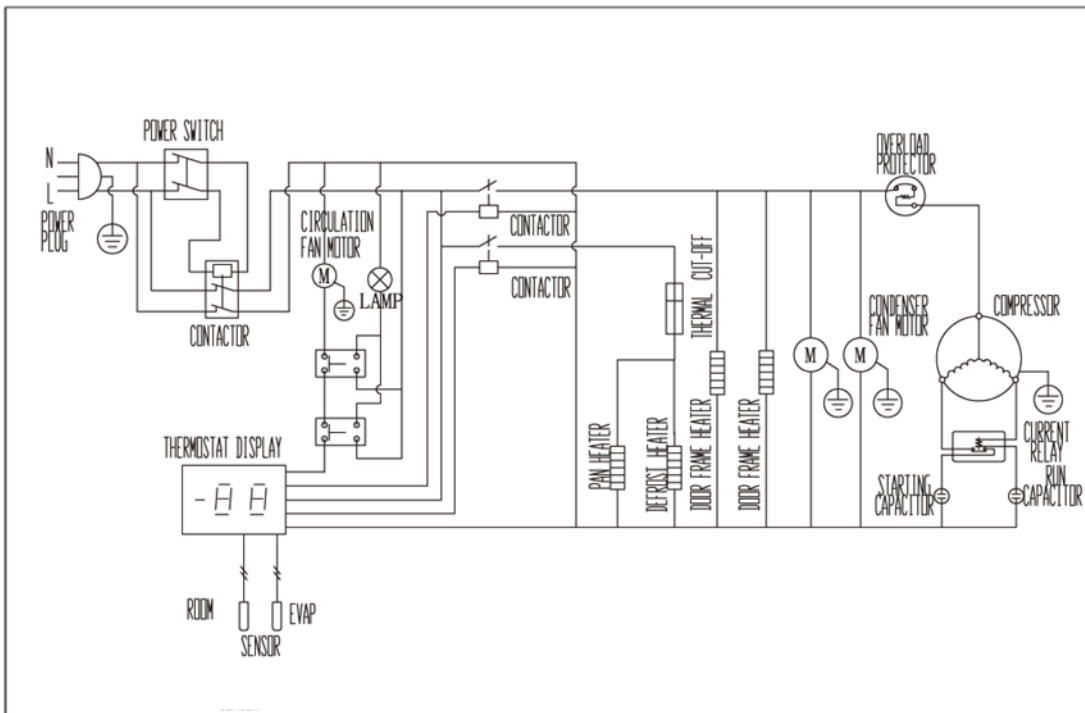

3. PARTS DETAILS

3-1. FRONT PANEL

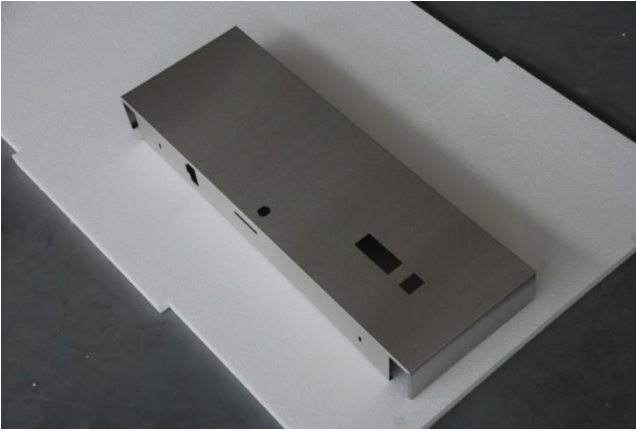

THERMOSTAT

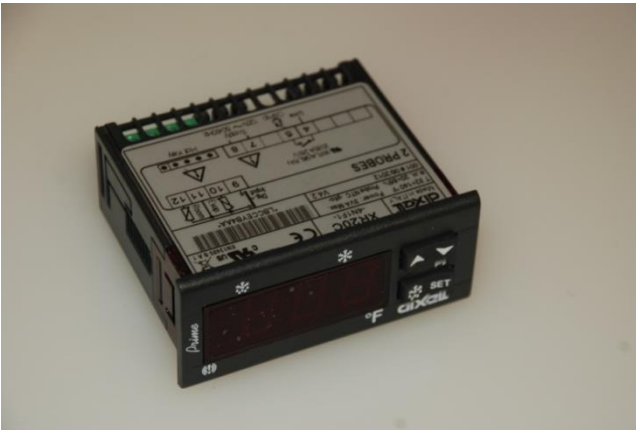

MAIN SWITCH

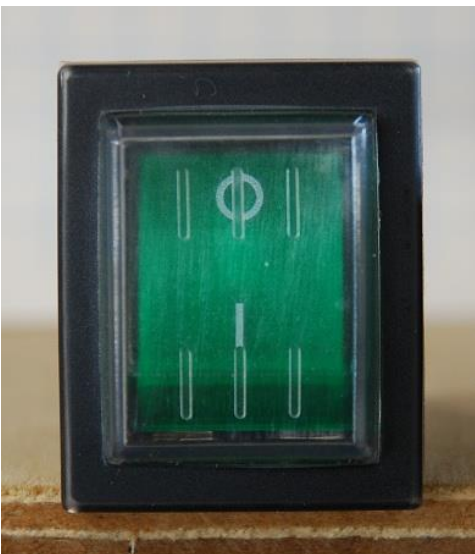

DOOR SWITCH



LOCK

3-2. REFRIGERATION COMPARTMENT CYCLE ASSEMBLY



CONDENSER

FILTER DRIER

CONDENSER FAN MOTOR

WATER PAN

COMPRESSOR

DRAIN PAN



CONDENSER FAN MOTOR ASSEMBLY



FAN COVER



CONDENSER FAN MOTOR BLADE

CONDENSER FAN MOTOR

3-3. DOOR

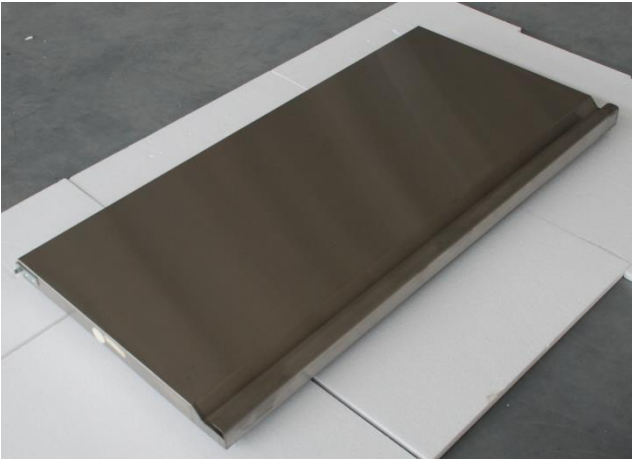

GASKET



Magnetic gasket can be replaced without any tools.



3-4. COOLING COMPARTMENT

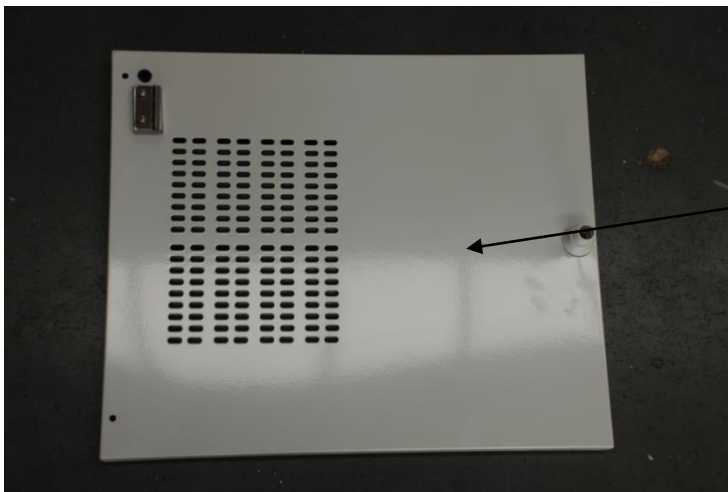

Circle Fan Cover

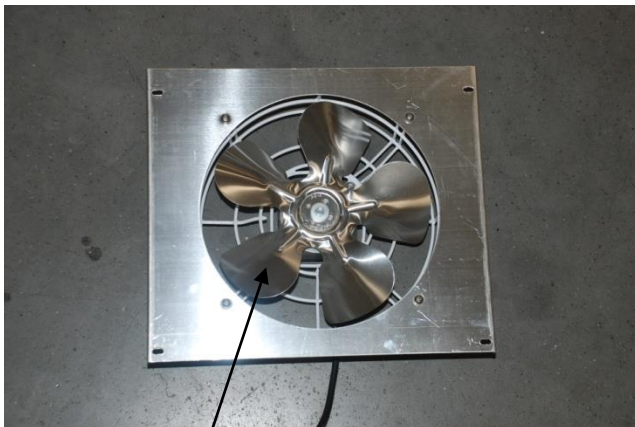

Evaporator Fan Motor Blade

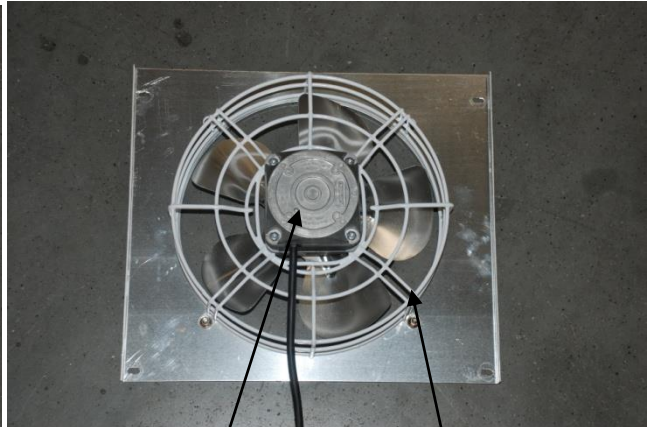

Evaporator Fan Motor

Fan Cover

Evaporator

Defrost Heating Element

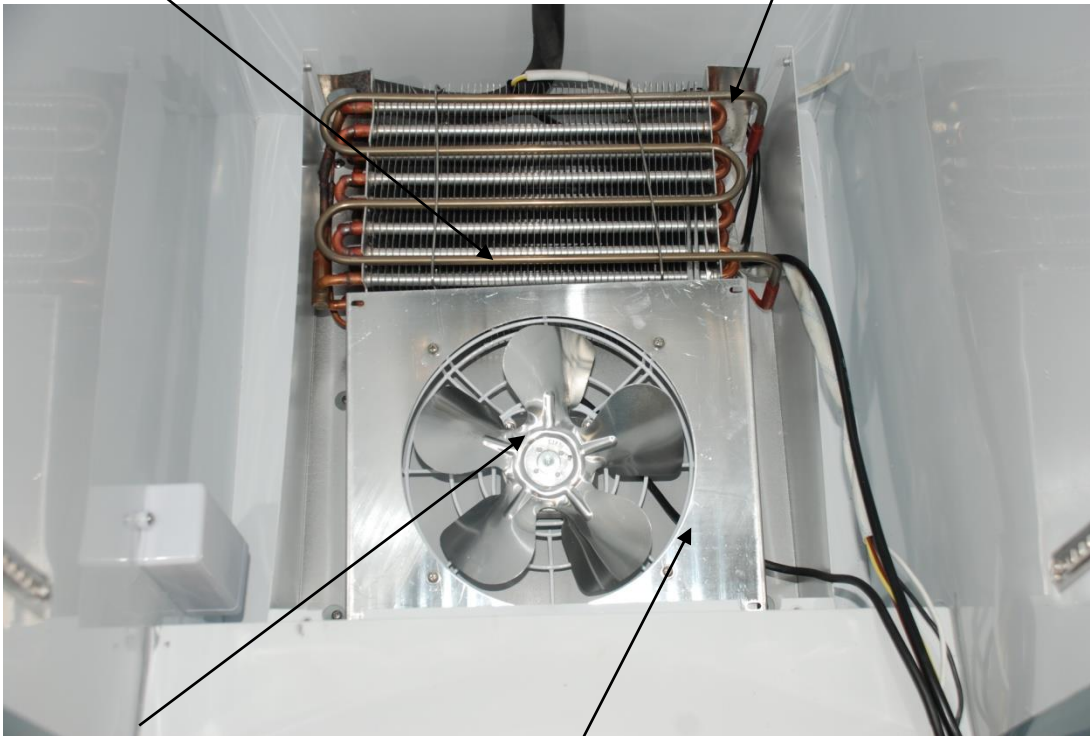

Evaporator Fan

Fan Support

4. MAIN COMPONENTS

4-1. COMPRESSOR

MODEL	P49F
Refrigerant	R-404a
Voltage	115V/60Hz
Comp. Model	T2180GK
Part code	54F.06

4-2. COMPRESSOR RELAY

	P49F
Voltage	115V / 60Hz
Relay Model	HLC-1XT04XA
Part code	27F.03

4-3. CONDENSER DRYER

MODEL	P49F
Refrigerant	R-404a
Spec.	XH-9 25g
Part code	GN1410TN.14

4-4. CAPACITOR

MODEL	P49F
Voltage	115V / 60Hz
Running	X
Starting	189-227 μ f

4-5. EVAPORATOR FAN MOTOR

MODEL	P49F
Voltage	115V / 60Hz
Motor Model	CA27-04/C20
Part code	27R.30

4-6. CONDENSER FAN MOTOR

MODEL	P49F
Voltage	115V / 60Hz
Motor Model	BD-03-04/C06
Part code	54F.09

4-7. EVAPORATOR DEFROST HEATER

MODEL	P49F
Voltage	115V / 60Hz
Spec.	800
Part code	54F.03

4-8. LAMP BULB

MODEL	P49F
Voltage	115V/60Hz
Spec.	25W
Part code	27R.29

4-9. MAIN PCB

MODEL	P49F
Voltage	115V / 60Hz
Part code	XR60CX
Micom code	27F.11

5. ELECTRONIC CONTROLLER INSTRUCTION

5-1-1

DIXELL XR60C PARAMETER FOR P49F

NO.	Label	Name	Range	Hidden Par.	Default °C/°F	°C	°F
1	Set	Set point	LS-US		-5/23	-22	-7
2	Hy	Differential	0.1-25.5°C/1-255°F		2/35.6	2	4
3	Ls	Minimum set point	-50°C-SET/-58°F-SET	Yes	-50/-58	-24	-11
4	Us	Maximum set point	SET-110°C/SET-230°F	Yes	110/230	-18	-1
5	Ot	Thermostat probe calibration	-12-12°C/-120-120°F		0/32	2	-1
6	P2P	Evaporator probe presence	n=not pres. ;y=pres.		Y	Y	Y
7	OE	Evaporator probe calibration	-12-12°C/-120-120°F	Yes	0/32	0	0
8	Ods	Outputs delay at start up	0-255min	Yes	0	2	2
9	AC	Anti-short cycle delay	0-50min		1	2	2
10	CCt	Continuous cycle duration	0.0-24.0h	Yes	0.0	0.0	0.0
11	COn	Compressor ON time with faulty probe	0-255min	Yes	15	10	10
12	COF	Compressor OFF time with faulty probe	0-255min	Yes	30	10	10
13	CF	Temperature measurement unit	°C/°F	Yes	°C/°F	°C	°F
14	rES	Resolution	in=integer; dE = dec .point		DE	DE	DE
15	Lod	Probe displayed	P1;P2	Yes	P1	P1	P1
16	tdF	Defrost type	EL= el.heater; dE= dec. point		EL	EL	EL
17	dtE	Defrost termination temperature	-50-50°C/-58-122°F		8/46.4	7	45
18	ldF	Interval between defrost cycles	1-120ore		6	6	6
19	MdF	(Maximum) length for defrost	0-255min		30	20	20
20	dsd	Start defrost delay	0-99min	Yes	0	0	0
21	DFd	Display during defrost	rt, it, Set, DEF	Yes	it	Set	set
22	dAd	MAX display delay	0-255min	Yes	30	30	30

		after defrost					
23	Fdt	Draining time	0-120min	Yes	0	2	2
24	dPo	First defrost after startup	n=after IdF; Y=immed	Yes	n	n	n
25	dAF	Defrost delay after fast freezing	0-23h n 50'	Yes	0.0	0	0
26	Fnc	Fan operation mode	c-n,o-n,c-y,o-y		o-n	o-n	o-n
27	Fnd	Fan delay after defrost	0-255min		10	2	2
28	Fct	Differential of temperature for forced activation of fans	0-50°C	Yes	10/50	10	50
29	FSt	Fan stop temperature	-50-50°C/-58-122°F		2/35.6	20	54
30	Alc	Temperature. Alarm configuration	rE=related to set; Ab=absolute	Yes	Ab	re	re
31	ALU	MAX. temperature alarm	SET-110°C/SET-230°F		110/230	50	90
32	ALL	MIN. temperature alarm	-50°C-SET/-58°F-SET		-50/-58	0	0
33	Ald	Temperature alarm delay	0-255min	Yes	15	99	99
34	dAO	Delay of temperature alarm at start up	0-23h n 50'	Yes	1.30	1	1
35	i1P	Digital input polarity	oP=opening ;CL=closing		CL	CL	CL
36	i1F	Digital input configuration	EAL=extern.alarm; bAL=lock regulation;PAL=press. switch; door=door switch;dEF=defrost; LHt =disabled; Htr=Cooling-heating		dor	dor	dor
37	did	Digital input alarm delay	0-255min		15	15	15
38	Nps	Number of activation of pressure	0-15	Yes	15	15	15
39	odc	Compressor status with open door	no,Fan=normal;CPr=comp.OFF;F-C=Compr.OFF & fan.OFF	Yes	F-C	F-C	F-C
40	Pbc	Kind of probe	Ptc;ntc		ntc/Ptc	ntc	ntc
41	dp1	Room probe display	-	Yes	-	P1	P1
42	dp2	Evaporator probe display	-	Yes	-	P2	P2
43	rEL	Software release	-	Yes	2.7	4.2	4.2
44	Ptb	Map code	-	Yes	-	4	4

5-1-2.

1. FRONT PANEL COMMANDS



SET: To display target set point, select a parameter or confirm an operation in programming mode.

- ❄ (DEF)** To start a manual defrost
- ▲ (UP)** To view the last alarm occurrence. In programming mode, it browses the parameter codes or increases the display value
- ▼ (DOWN)** To view the last alarm occurrence. In programming mode, it browses the parameter codes or decreases the display value

KEY COMBINATION

- ▲ + ▼** To lock & unlock the keyboard
- SET + ▼** To enter in programming mode
- SET + ▲** To return to the room temperature display

1.1 Function of LEDS

LED	MODE	FUNCTION
❄	ON	Compressor enabled
❄	Flashing	- Programming Phase (flashing with ❄) - Anti-short cycle delay enabled
❄	ON	Defrost enabled
❄	Flashing	- Programming Phase (flashing with ❄) - Drip time in progress
🌀	ON	Fans enabled
🌀	Flashing	Fans delay after defrost in progress.
🔊	ON	A temperature alarm occurred

2. MAIN FUNCTIONS

2.1 HOW TO VIEW THE SET POINT

1. Push and immediately release the **SET** key: the display will show the set point value.
2. Push and immediately release the **SET** key or wait for 5 seconds to display the sensor value again.



2.2 HOW TO CHANGE THE SET POINT

1. Push the **SET** key for more than 2 seconds to change the set point value.
2. The value of the set point will be displayed and the ❄️ LED starts blinking.
3. To change the set value, push the ▲ or ▼ key within 10s.
4. To set new point value, push the SET key again or wait 10s.

2.3 HOW TO START A MANUAL DEFROST

Push the ❄️ key for more than 2 seconds and a manual defrost will start



2.4 HOW TO LOCK THE KEYBOARD

1. Hold the ▲ and ▼ keys for more than 3s.
2. The "POF" message will be displayed and the keyboard will be locked. At this point, it will be possible only to see the set point or the MAX or Min temperature stored.
3. If a key is pressed more than 3s the "POF" message will be displayed.



2.5 HOW TO UNLOCK THE KEYBOARD

Hold the ▲ and ▼ keys together for more than 3s, till the "POF" message is displayed.

3. ALARM SIGNALS

HOW TO VIEW THE ALARM AND RESET THE RECORDED ALARM

1. Hold the ▲ or ▼ key to display the alarm signals.
2. When the signal is displayed, hold the **SET** key until the "rst" message is displayed. Push the **SET** key again. The "rst" message will start blinking and the normal temperature will be displayed again.

Message	Cause	Outputs
"P1"	Room probe failure	Compressor output according to par. "Con" and "COF"
"P2"	Evaporator probe failure	Defrost end is timed.
"P3"	Condenser probe failure	Outputs unchanged.
"HA"	Maximum temperature alarm	Outputs unchanged.
"LA"	Minimum temperature alarm	Outputs unchanged.
"dA"	Door open	Compressor and fans restart.
"EA"	External alarm	Output unchanged.
"CA"	Serious external alarm (i1F=bAL)	All outputs OFF.
"Csd"	Condenser alarm	All outputs OFF.

6. REPLACEMENT OF MAIN COMPONENTS

6-1. FRONT PANEL PARTS

UNSCREW THE FRONT PANEL



A. LIFT THE PANEL





You can change the door switch, lock main switch and the thermostat here

6-2. REFRIGERATION COMPARTMENT PARTS

6-2-1. UNSCREW THE SENSOR CLIP AND TAKE THE SENSOR OUT FROM THE CLIP



6-2-2. UNSCREW THE CIRCLE FAN COVER



6-2-3. PULL DOWN THE CIRCLE FAN COVER.



6-2-4. UNSCREW THE FAN SUPPORT





- 6-2-5. CHANGE THE DEFROST HEATING ELEMENT**
a. UNHOOK THE EVAPORATOR FROM ITS CASING

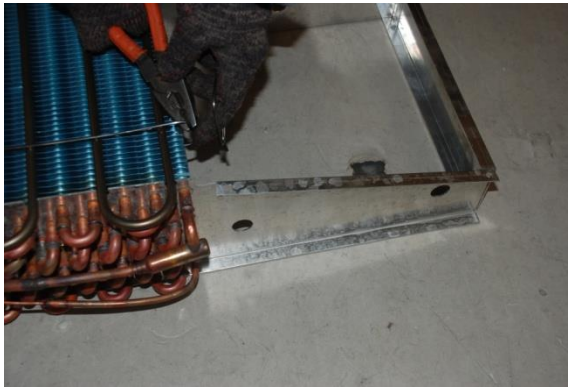

- b. TAKE OFF THE ELEMENT AND REPLACE IT.**

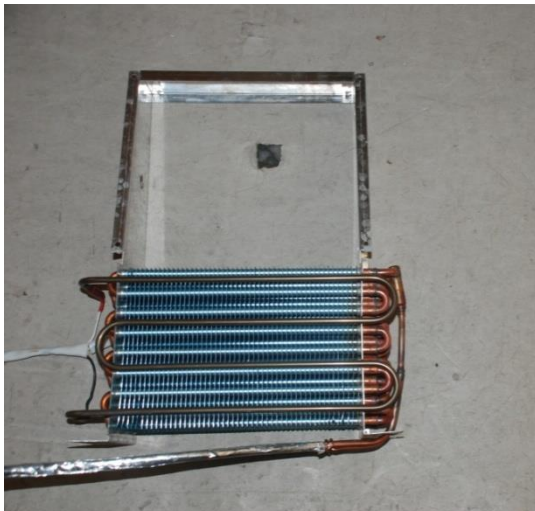

6-3. CONDENSING UNIT

6-3-1. TAKE OFF THE BOTTOM PANEL OF THE UNIT.



6-3-2. UNSCREW THE UNIT BOARD. YOU CAN PULL THE UNIT BOARD OUT FOR ANY REPAIRS OR CLEANING.

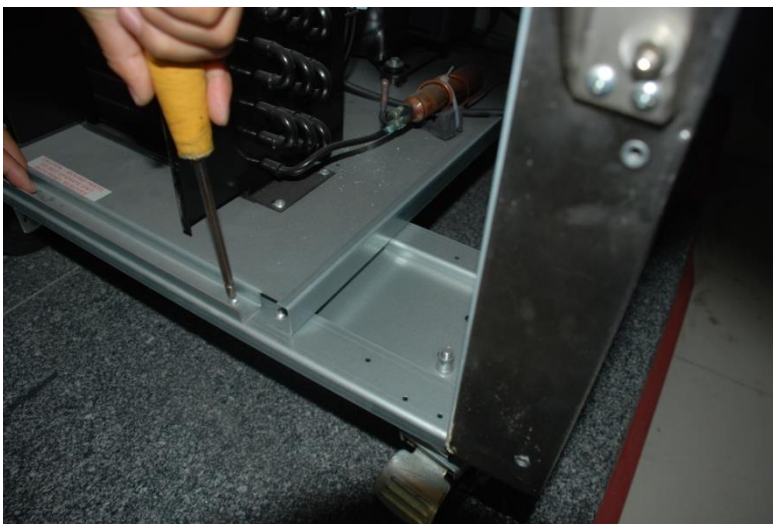



CAUTION: BE CAREFUL OF ELECTRIC SHOCK



CAUTION: MAKE SURE THE POWER SUPPLY IS CUT OFF BEFORE ANY SERVICE IS PERFORMED



CAUTION: CONDENSING UNIT MAY BE VERY HOT. BE SURE IT IS COOL BEFORE ANY SERVICE IS PERFORMED