



INSTRUCTIONS

-J05646

REV. 2013-12-13

ELECTRA GLO™ TRIM RING KITS FOR 4 INCH AUXILIARY LAMPS

GENERAL

Kit Numbers

61400094, 61400141

Models

For model fitment information, see the P&A retail catalog or the Parts and Accessories section of www.harley-davidson.com (English only).

Installation Requirements

Unless installing an Electra Glo trim ring kit for the vehicle headlamp, **2014-later FLHR (Road King) models** require separate purchase of a jumper harness (Part No. 69200850).

Electrical Contact Lube (Part No. 99861-02) or equivalent is required for all unprotected electrical terminals, and after battery cable disconnection. This item is available from a Harley-Davidson dealer.

Use an assistant to aid in the testing procedure.

WARNING

The rider's safety depends upon the correct installation of this kit. Use the appropriate service manual procedures. If the procedure is not within your capabilities or you do not have the correct tools, have a Harley-Davidson dealer perform the installation. Improper installation of this kit could result in death or serious injury. (00333a)

NOTE

This instruction sheet refers to service manual information. A service manual for this year/model motorcycle is required for this installation. One is available from a Harley-Davidson dealer.

ELECTRICAL OVERLOAD

NOTICE

It is possible to overload your vehicle's charging system by adding too many electrical accessories. If the combined electrical accessories operating at any one time consume more electrical current than the vehicle's charging system can produce, the electrical consumption can discharge the battery and cause damage to the vehicle's electrical system. See an authorized Harley-Davidson dealer for advice about the amount of current consumed by additional electrical accessories or for necessary wiring changes. (00211c)

WARNING

When installing any electrical accessory, be certain not to exceed the maximum amperage rating of the fuse or circuit breaker protecting the affected circuit being modified. Exceeding the maximum amperage can lead to electrical failures, which could result in death or serious injury. (00310a)

This kit requires up to **270 mA** more current from the electrical system.

Kit Contents

See Figure 1 and Table 1.

PREPARATION

WARNING

To prevent accidental vehicle start-up, which could cause death or serious injury, remove main fuse before proceeding. (00251b)

NOTE

- **For 2007- later vehicles equipped with security siren:** With security fob present, turn ignition switch ON. After system is disarmed, turn ignition switch OFF. **IMMEDIATELY** remove the main fuse per the service manual.
- **For 2006- earlier vehicles equipped with security siren:** Disarm the siren with the key fob or security code. See the service manual to remove the main fuse.
- **For vehicles WITHOUT security siren:** See the service manual to remove the main fuse.

For Vehicles With Main Fuse:

1. Remove the seat per the service manual. Retain the seat and all mounting hardware.
See the service manual to remove the main fuse.

For Vehicles With Main Circuit Breaker:

WARNING

To prevent accidental vehicle start-up, which could cause death or serious injury, disconnect negative (-) battery cable before proceeding. (00048a)

1. See the service manual to remove the seat and disconnect the negative (black) battery cable from the negative battery terminal. Retain all seat mounting hardware.
2. **ALL models:** Turn the ignition OFF unless already done.

INSTALLATION

ALL Models:

NOTE

If also installing an Electra Glo trim ring kit for the vehicle headlamp, install **that** kit now, up to the point where the headlamp trim ring wires and socket terminals are inserted into the two-way socket housing.

1. While maintaining the position of the auxiliary lamp and nesting ring, remove the screw and locknut at the bottom of each currently installed auxiliary lamp bezel ring. Remove the rings.

Retain the nuts for assembly. Discard the screws.

NOTE

The Electra Glo trim rings are side-specific. The rings install with the wire exit on the inboard side.

2. See Figure 1. Get the right side trim ring (1) from the kit. Snap the trim ring over the auxiliary lamp and nesting ring, and into the groove on the auxiliary lamp housing. Make sure that:
 - a. the tabs on the auxiliary lamp engage the notches on the nesting ring,
 - b. the tab on the nesting ring is angled away from the auxiliary lamp,
 - c. the tab on the nesting ring engages the notch in the lamp housing, and
 - d. Verify that the lamp does not pinch the Electra Glo trim ring wires.
3. Get a screw (12) and lockwasher (13) from the kit. Slide the lockwasher onto the screw threads. Insert the screw assembly through the trim ring. Thread the locknut saved earlier onto the screw. Tighten to 6-10 **in-lbs** (0.68-1.13 N-m).
4. Repeat steps with the left side trim ring.
5. Proceed to the **CONNECTION** section for the specific model.

CONNECTION

2013-Earlier Road King Models With Auxiliary Lamps

1. Remove the headlamp trim ring per the service manual.
2. Remove the headlamp retaining ring. Remove the headlamp.
3. Route the wiring for both Electra Glo trim rings rearward, alongside the auxiliary lamp wiring and up into the nacelle.
4. Obtain harness 69200604 (8) from the kit.
Plug the black wire spade terminal on the jumper harness into the black HDI position lamp terminal.
Plug the Orange/White wire spade terminal on the jumper harness into the Orange/White HDI position lamp terminal.
5. Obtain harness 69200603 (4) from the kit. Plug the harness into jumper harness 69200604.
6. **WITH Electra Glo headlamp trim ring kit:** Remove the dust cover from the third connector on the harness. Plug in the headlamp trim ring connector.

WITHOUT Electra Glo headlamp trim ring kit: Plug the left and right trim ring connectors into the two open connectors on the harness.

7. **ALL installations:** Use the cable straps (10) and adhesive backed clips (11) from the kit to secure the wiring within the nacelle. Make sure wires do not pull tight when handlebars are turned fully to left or right fork stops.
8. Install the headlamp and headlamp retaining ring using the OE hardware.
9. Install the headlamp trim ring.
10. Proceed to the **COMPLETION** section.

2013-Earlier Electra Glide, Street Glide, Trike Models With Auxiliary Lamps

1. Remove the outer fairing per the service manual.
2. Route the trim ring wiring rearward, alongside the auxiliary lamp wiring and into the inner fairing.
3. Obtain harness 69200604 (8) from the kit.
Plug the black wire spade terminal on the jumper harness into the black HDI position lamp terminal.
Plug the Orange/White wire spade terminal on the jumper harness into the Orange/White HDI position lamp terminal.
4. Obtain harness 69200603 (4) from the kit. Plug the harness into jumper harness 69200604.
5. **WITH Electra Glo headlamp trim ring kit:** Remove the dust cover from the third connector on the harness. Plug in the headlamp trim ring connector.

WITHOUT Electra Glo headlamp trim ring kit: Plug the left and right trim ring connectors into the two open connectors on the harness.

6. **ALL installations:** Use the cable straps (10) and adhesive backed clips (11) from the kit to secure the wiring within the inner fairing. Make sure wires do not pull tight when handlebars are turned fully to left or right fork stops.
7. Install the outer fairing per the service manual.
8. Proceed to the **COMPLETION** section.

2014-Later Road King Models With Auxiliary Lamps

1. Remove the headlamp trim ring per the service manual. Retain all components.
2. Remove the headlamp retaining ring. Remove the headlamp.
3. Route the wiring for both Electra Glo trim rings rearward, up into the nacelle.
4. Unplug the main harness from the accessory power (right side) toggle switch connector [C67A].
5. Get the jumper harness (Part No. 69200850, purchased separately). Plug the jumper harness into the open connectors.
6. Attach the ground wire from the jumper harness to the ground screw on the fork bracket.
7. Secure the jumper harness to existing wiring using the cable straps (10) from the kit.

8. Obtain harness 69200603 (4) from the kit. Plug the harness into jumper harness 69200850.
9. **WITH Electra Glo headlamp trim ring kit:** Remove the dust cover from the third connector on the harness. Plug in the headlamp trim ring connector
WITHOUT Electra Glo headlamp trim ring kit: Plug the left and right trim ring connectors into the two open connectors on the harness.
10. **ALL installations:** Use the cable straps (10) and adhesive backed clips (11) from the kit to secure the wiring within the nacelle. Make sure wires do not pull tight when handlebars are turned fully to left or right fork stops.
11. Install the headlamp and headlamp retaining ring using the OE hardware.
12. Install the headlamp trim ring.
13. Proceed to the **COMPLETION** section.

2014-Later Electra Glide, Street Glide, Trike Models With Auxiliary Lamps

1. Remove the outer fairing per the service manual.
2. Temporarily install the auxiliary lamp mount assemblies if removed in step 1.
3. Route the wiring for both Electra Glo trim rings through the gap between the handlebars and fairing, into the inner fairing. Tuck the external wiring into the gap between the auxiliary lamp mount and the inner fairing.
4. Obtain harness 69200603 (4) from the kit. Plug the harness into the OE accessory connector [299].
5. **WITH Electra Glo headlamp trim ring kit:** Remove the dust cover from the third connector on the harness. Plug in the headlamp trim ring connector.
WITHOUT Electra Glo headlamp trim ring kit: Plug the left and right trim ring connectors into the two open connectors on the harness.
6. **ALL installations:** Use the cable straps (10) and adhesive backed clips (11) from the kit to secure the wiring within the inner fairing. Make sure wires do not pull tight when handlebars are turned fully to left or right fork stops.
7. Loosen the upper auxiliary lamp mount nuts. Remove the lower nuts. Pivot the auxiliary lamp mount assemblies rearward to position the outer fairing.
8. Install the outer fairing per the service manual.
9. Proceed to the **COMPLETION** section.

2012-Later Dyna Switchback Models With Auxiliary Lamp Kit

1. Remove the headlamp trim ring per the service manual.
2. Remove the headlamp retaining ring. Remove the headlamp.
3. Route the wiring for both Electra Glo trim rings toward the center of the vehicle and up into the nacelle.
4. Obtain harness 69200604 (8) from the kit.
Plug the black wire spade terminal on the jumper harness into the black HDI position lamp terminal.

Plug the Orange/White wire spade terminal on the jumper harness into the Orange/White HDI position lamp terminal.

5. Obtain harness 69200603 (4) from the kit. Plug the harness into jumper harness 69200604.
6. **WITH Electra Glo headlamp trim ring kit:** Remove the dust cover from the third connector on the harness. Plug in the headlamp trim ring connector.
WITHOUT Electra Glo headlamp trim ring kit: Plug the left and right trim ring connectors into the two open connectors on the harness.
7. **ALL installations:** Use the cable straps (10) and adhesive backed clips (11) from the kit to secure the wiring within the nacelle. Make sure wires do not pull tight when handlebars are turned fully to left or right fork stops.
8. Install the headlamp and headlamp retaining ring using the OE hardware.
9. Install the headlamp trim ring.
10. Proceed to the **COMPLETION** section.

Dyna Models (Except Switchback) With Auxiliary Lamp Kit

1. Remove the fuel tank per the service manual to gain access to the headlamp connector.
2. Unplug the headlamp connector from the vehicle harness. Snap open the secondary lock on the rear of the headlamp connector.
3. Obtain harness 69200696 (9) from the kit. Insert the orange/white wire socket terminal into the open cavity of the headlamp connector. Reference other terminals in the connector for proper orientation.
Push in the terminal until it clicks. Gently pull on the wire to make sure that it is fully seated.
4. Close the headlamp connector secondary lock. Plug the connector into the vehicle harness.
5. Route the harness black ground wire down the frame backbone. Install the ring terminal to a ground stud on the frame, the negative battery terminal or another suitable grounding location.
6. Obtain harness 69200603 (4) from the kit. Plug the harness into the open connector on harness 69200696.
7. Plug the left and right Electra Glo trim ring connectors into the two open connectors on harness 69200603.
8. Secure the trim ring wiring under the fuel tank with the cable straps and clips from the kit. Install the fuel tank and seat per the service manual.
9. Proceed to the **COMPLETION** section.

Softail Models With Auxiliary Lamps

1. Obtain harness 69200603 (4) from the kit.
2. Route the trim ring wires toward the center of the vehicle.
3. **WITH Electra Glo headlamp trim ring kit:** Remove the dust cover from the third connector on the harness. Plug in the headlamp trim ring connector.

WITHOUT Electra Glo headlamp trim ring kit: Plug the left and right trim ring connectors into the two open connectors on the harness.

4. **FLSTC models:** Unplug the fender tip light at the left front of the fuel tank. Install jumper harness 69200602 (6) from the kit. Plug the fender tip light into the one of the connectors on the jumper harness. Plug the Electra Glo trim ring connector into the remaining jumper harness connector.

Softail models EXCEPT FLSTC: Plug the harness into the open connector on the headlamp harness located under the left side of the fuel tank.

5. **ALL models:** Secure the trim ring wiring behind the nacelle or along the frame behind the fuel tank with cable straps and clips from the kit.
6. Proceed to the **COMPLETION** section.

XL Models With Auxiliary Lamp Kit

1. Remove the fuel tank per the service manual to gain access to the headlamp connector.
2. Unplug the headlamp connector from the vehicle harness. Snap open the secondary lock on the rear of the headlamp connector.
3. Obtain harness 69200696 (9) from the kit. Insert the orange/white wire socket terminal into the open cavity of the headlamp connector. Reference other terminals in the connector for proper orientation.
Push in the terminal until it clicks. Gently pull on the wire to make sure that it is fully seated.
4. Close the headlamp connector secondary lock. Plug the connector into the vehicle harness.
5. Route the harness black ground wire down the frame backbone. Install the ring terminal to a ground stud on the frame, the negative battery terminal or another suitable grounding location.
6. Obtain harness 69200603 (4) from the kit. Plug the harness into the open connector on harness 69200696.
7. Plug the left and right trim ring connectors into the two open connectors on harness 69200603.

8. Secure the trim ring wiring under the fuel tank with the cable straps and clips from the kit. Install the fuel tank and seat per the service manual.

9. Proceed to the **COMPLETION** section.

COMPLETION

WARNING

Be sure that steering is smooth and free without interference. Interference with steering could result in loss of vehicle control and death or serious injury. (00371a)

- **Make sure wires, clutch cables, throttle/idle cables and brake lines do not pull tight when handlebars are turned fully to left or right fork stops.**

NOTE

Verify that the ignition is OFF before installing the main fuse or attaching the negative battery cable.

1. **Models with main fuse:** See the service manual to install the main fuse.

Models with main circuit breaker:

- a. **ALL models except XL:** See the service manual to attach the negative battery cable. Apply a light coat of Electrical Contact Lube (Part No. 99861-02) or equivalent to battery terminals.
 - b. **XL models only:** See the service manual to connect the negative battery cable at the engine crankcase.
2. **ALL models:** Test the Electra Glo Trim Ring for proper operation:
 - a. Turn ignition switch OFF. The trim ring LEDs are OFF.
 - b. Turn ignition switch to ACC. The trim ring LEDs are ON.
 - c. Turn ignition switch ON. The trim ring LEDs are ON.

WARNING

After installing seat, pull upward on seat to be sure it is locked in position. While riding, a loose seat can shift causing loss of control, which could result in death or serious injury. (00070b)

3. See the service manual to install the seat.

SERVICE PARTS

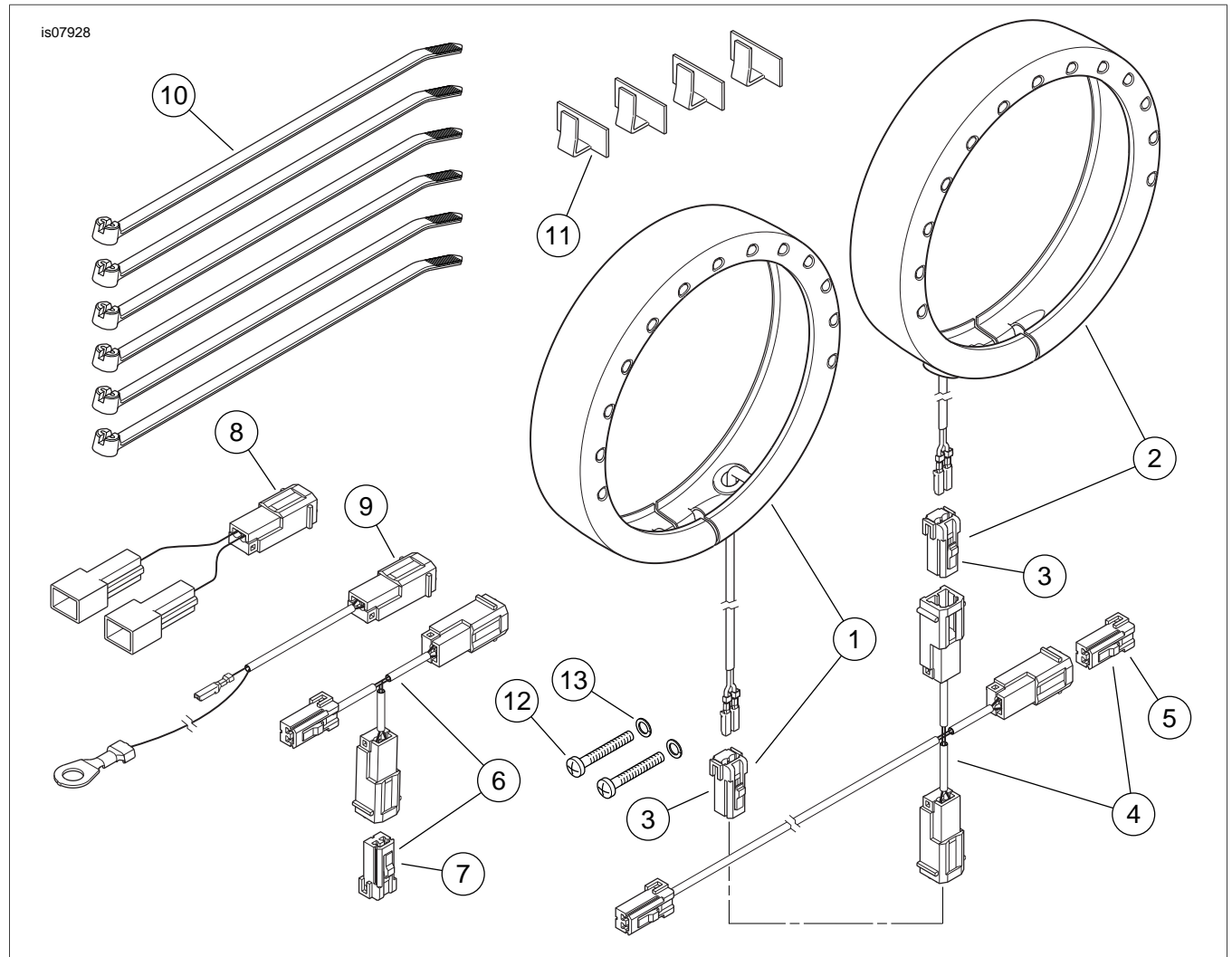

Figure 1. Service Parts, Electra Glo Trim Ring Kits for Four Inch Auxiliary Lamps

Table 1. Service Parts

Kit	Item	Description (Quantity)	Part Number
Kit 61400094 (Chrome)	1	Electra Glo trim ring, 4 in, right (Chrome) (includes Item 3)	61400186
	2	Electra Glo trim ring, 4 in, left (Chrome) (includes Item 3)	61400258
Kit 61400141 (Black)	1	Electra Glo trim ring, 4 in, right (Black) (includes Item 3)	61400187
	2	Electra Glo trim ring, 4 in, left (Black) (includes Item 3)	61400259
Common Parts for All Kits.	3	• Two-way socket housing, Tyco/Amp (2)	73152-96BK
	4	Wire harness, auxiliary lamp trim ring (includes Item 5) (ALL models)	69200603
	5	• Two-way socket housing, Tyco/Amp (used as dust cover)	73152-96BK
	6	Wire harness, auxiliary lamp trim ring (includes Item 7) (FLST models)	69200602
	7	• Two-way socket housing, Tyco/Amp (used as dust cover)	73152-96BK
	8	Wire harness, auxiliary lamp trim ring (FLD, FLHR, FLHT models)	69200604
	9	Wire harness, auxiliary lamp trim ring (FXD, XL models)	69200696
	10	Cable strap (6)	10065
	11	Clip, adhesive back (4)	10102
	12	Screw, fillister head, #8-32 x 1.25 in (32 mm) long (2)	3383
	13	Split lockwasher. #8 (2)	7015