

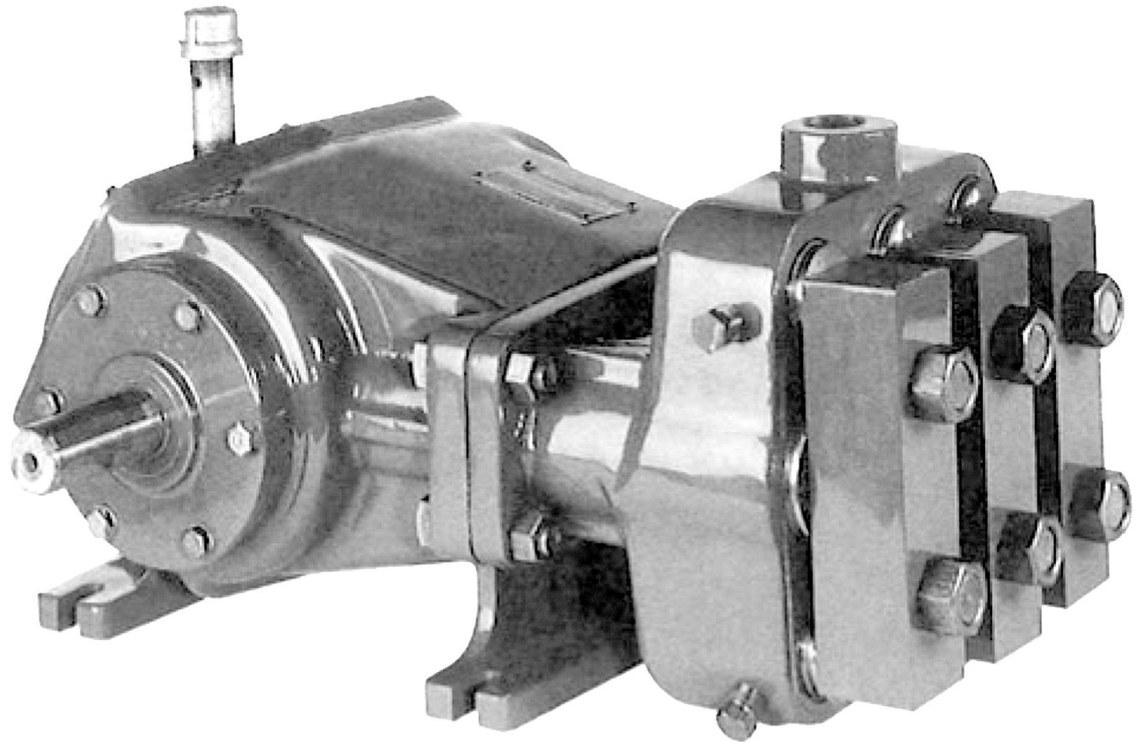

MYERS®



C25-C35-C40 SERIES INDUSTRIAL PUMPS

INSTALLATION AND SERVICE MANUAL

NOTE! To the installer: Please make sure you provide this manual to the owner of the equipment or to the responsible party who maintains the system.

INSTRUCTIONS

Positive displacement pumps must have a proper size and operable type of pressure regulating valve or pressure relief valve piped into the discharge line. This is mandatory to prevent damage to pump and piping or possible injury to personnel. Do not install any valves or shut-off devices in the bypass line from pressure regulator to the tank or supply.

All pumps should be installed level. For mobile applications the maximum angle of intermittent operation should be no more than 5 degrees in any one direction.

CALIFORNIA PROPOSITION 65 WARNING:

⚠ WARNING This product and related accessories contain chemicals known to the State of California to cause cancer, birth defects or other reproductive harm.

It is recommended to install a pulsation dampener in the discharge line to smooth out pressure pulse. This can protect pump parts and piping for longer life and quieter operation.

BELT DRIVE

With belt drives, the pulley on both the engines and pump should be located as close as possible to the bearing to reduce bearing and shaft bending loads. Make sure that all bolts, nuts, set screws and keys are properly tightened.

STARTING PUMP

Fill pump crankcase with recommended oil (SAE 30) to the level mark on the oil saber. Replace all drain plugs in pump and piping. Inspect tank to be sure that no foreign material is in tank or suction line. Fill tank at least half full or connect suction to water supply. Open valve (if present) in suction line. Avoid prolonged dry operation which may cause excessive wear on piston packing. Be sure that an operating pressure gauge is located in discharge line. Use a heavy duty, liquid filled, pulsation-free pressure gauge. Make sure all valves, including spray gun or nozzles, are open in discharge line. Spray gun may be anchored to discharge back into tank. Completely back off pressure adjusting device on the pressure regulating valve. Check pressure rating for pulsation dampener pressure regulator and pipe fitting to make sure working pressure is not over maximum pressure rating.

After starting, close discharge valve or spray gun slowly while watching pressure gauge to make sure relief valve or unloader is operating properly. Adjust relief valve or unloader to desired pressure. Cycle nozzles or gun on and off to be sure that pressure adjustment and regulator operation is satisfactory. Nozzle capacity should not exceed 90% of pump capacity for satisfactory regulator operation. Avoid freezing by draining all water from the pump and system in cold weather. There is a 3/8 NPT drain plug for each cylinder chamber.

SUGGESTED MAINTENANCE SCHEDULE

Check oil level – Daily

Drain and change oil (SAE 30) – 300 hrs.
Drain at operating temperature to prevent contamination from settling.

Inspect piston packing and spacer rings – 500 hrs.
Inspect frequently for leakage; piston packing is allowed to drip in order to cool and lubricate packing. Replace if there is a stream leak.

Inspect valves and springs – 500 hrs.
Replace if cracks and heavy wear are present.

Inspect connecting link bearing inserts – 1000 hrs.
Replace at first signs of fatigue or wear to prevent damage to crankshaft.

Inspect crankshaft tapered roller bearings and piston stud – 2000 hrs.
Replace if there is any pitting on the seal surface or if the surface is rough.

LUBRICATION

Pump – Fill crankcase with 2 qts of oil. Maintain oil level between the high and the low level marks on bayonet oil gauge inserted through the crankcase cover. Add extra quart for crankshaft speeds under 300 rpm.

Drain oil from crankcase after first 30 hours of operation. Refill with proper oil. Check oil levels regularly. Change oil immediately if water droplets are found on bayonet gauge.

SERVICE

Disconnect electrical leads to motor or remove spark plug leads on engine before proceeding.

REPLACING PISTON PACKING

Loosen cap screw to remove piston assembly through the cylinder opening. Use waterproof grease to lubricate piston packing and O-ring on cylinder caps.

REPLACING VALVE SEATS

Pass head of puller through the hole in the valve seat before the sliding piece is inserted alongside the puller bolt. Place valve cap clamp on the puller bolt along with the nut for extracting the valve seat. Place the new valve seat in the tapered hole in the cylinder body and place a soft brass rod against valve set and drive into place. Do not use a hand or arbor press as it may crack the cylinder body.

REPLACING CYLINDER LINERS

Remove piston packing and rotate crankshaft until the piston rod is in rear position. Insert puller through the inside of cylinder and insert disc into the slots on the puller. Slip plate over the threads on the puller and screw the nut on the thread in the puller. Tighten nut until the liner breaks loose and then loosen nut and slip disc out of slots. Remove puller and repeat to remove remainder of cylinder liners.

Clean out any accumulation of loose rust or corrosion in tapered cylinder. Inspect O-ring and replace it if damaged. Insert liner into position by hand then firmly drive in. Never use a hand or hydraulic arbor press as it may shrink the liner.

REPLACING PISTON ROD SEALS

The rod seal assembly contains two seals and two oil seals with lips facing power end. The oil seal can be replaced without taking the fluid end off by removing the

cylinder and piston to allow access to the oil seal housing. Unscrew Allen screws and place them into the other two tapped holes. Gradually screw them in to push the oil seal housing off the retainer. After assembling new seals in the oil seal housing, an assembly thimble should be used on the end of the crosshead rod for sliding the oil seal housing back into the retainer. Check gasket and replace if damaged.

An assembly thimble should be used on the small end of the piston rod to expand the sealing edge as it is pushed on. The thimble should be machined from high carbon steel and polished on the exterior to reduce the possibility of seal lip damage.

SERVICING CRANKCASE PARTS

To remove the crankshaft you do not need to remove the cylinder body from the crankcase. Remove the connecting link caps from the connecting links and push the free links toward the cylinder end as far as possible. Take off the bearing caps and pull the crankshaft through the bearing opening. The connecting links and link caps are mated to each other and should be reinstalled in the same position they were in before they were taken apart.

REPLACING CRANKSHAFT AND SHIMMING BEARINGS

Remove bolts from both bearing caps. Carefully remove bearing cap, shims and O-rings and discard shims and O-rings. Inspect and clean shim surfaces on both bearing caps and crankcase.

Slide crankshaft into the crankcase and rest bearings on the sides of the crankcase. Place .045" shim on the drive side bearing cap and place 4.38" O.D. O-ring onto the bearing cap.

Cover key-way slot and slide the bearing cap with oil seal over the drive shaft. Tighten the cap screws. Install the non-drive side cap without shims or O-ring. Secure with cap screws and tighten alternately so the crankshaft can be fully rotated by hand to seat the tapered roller bearings.

Measure the shim gap adjacent to each of the screws by inserting a flat feeler gauge in the gap until it bottoms out. The required shim thickness for this cap is equal to the average of the two gap measurements, plus .005" constant.

Remove the two bolts and cap and place the correct shim thickness on this cap. If the required shim thickness does not match an .003" increment of a green shim, round up or down to the nearest .003" shim increment.

Remove non-drive side bearing cap and place the 4.38" O.D. O-ring on the cap and reinstall. Tighten the screws as the crankshaft is fully rotated by hand to seat the bearings and so no significant binding results.

SERVICING CONNECTING LINKS

When the connecting link bearings are worn, standard replacement bearing inserts can be installed in the connecting links. Do not change the size of the bearing or the link by filing or grinding the faces. When reinstalling the links on the crankshaft be sure to place the oil holes upward for proper lubrication.

RECOMMENDED TORQUE (foot-pounds)

Fastener Location
Link Bearing Caps - 25
Crankshaft End Caps -20
Cap Screw Holding Piston -20
Packing Assembly to Piston Rod - 20
Valve and Cylinder Cover Plate - 200
Cap Screw (Fluid End to Crankcase) - 1/2"-50 and 5/8"-80

CROSSHEAD AND PISTON RODS

Repair parts for the crosshead and piston rod are supplied as a complete unit. If either of these parts becomes worn, it is necessary to replace both the crosshead and piston rod. Under normal conditions a crosshead will not wear, nor will the bore of the crankcase wear, to the extent that replacement will be required. A clearance of .002" to .004" is standard for the crosshead.

RECONDITIONING CRANKSHAFTS

When crank pins are slightly damaged, they can sometimes be reconditioned for further use. This can be done with emery cloth and polishing, until all ridges are completely removed. The final polishing operation should be performed by using a very fine emery cloth. This procedure can be followed only where the amount of sanding does not reduce the normal diameter of the crank pin.

Worn or corroded crank pins can be ground and polished down to .030" under the size when the cranks were new. The undersize bearing halves are made especially for turned down crankshafts.

If the surface is badly damaged, the crankshaft can often be salvaged by "metalizing" the crank pins, regrinding and polishing to the original diameter.

When installing new bushings for the crosshead pin, these bushings should be reamed to the proper size after pressing into the link.

When assembling bearings on the crankshaft, an oil seal expander thimble should be used at the end of the shaft. A thimble of this type will cause the lip of the oil seal to gradually expand up to the shaft diameter allowing it to slip onto the shaft without turning or damaging the seal in any way. A slight nick or cut in the lip can damage a seal enough that it will not retain the oil properly.

Warning – This pump must be installed with a pressure relief valve in discharge line.

5. If the pressure regulator internal bypass valve is worn, it will allow too much of the pump capacity to be bypassed and recirculated back to the tank. By examining the flow from this valve with the discharge turned on, it can be determined whether or not the valve is worn. If a heavy flow continues when the discharge is turned on, it is usually a good indication of a worn valve and should be replaced.
6. Worn plunger cups, valves or valve seats will cause a severe drop in pump capacity pressure. Worn plunger cups are detected by water leakage past the cups and should be replaced immediately. Water getting into the pump crankcase will cause severe corrosion of the bearings. Worn valves can only be detected by visual examination of each valve assembly. Abrasive liquid will cause wire cuts which begin as a very small groove, but increase rapidly once the valve starts to leak through this groove. If the valve plates are replaced as soon as they start to show this cutting action, it will prevent the valve seat from becoming cut in a similar manner.
7. Pump cylinder bodies withstand an extreme amount of shock and pulsation while in operation, but if the pump is allowed to freeze, by not being drained, the freezing may crack the cylinder body walls in almost any location. If the crack occurs on the suction valve or cylinder portion of the body, it may allow a small amount of air to enter on the suction stroke and cause noisy operation or a decrease in pumping capacity. If the crack develops in the walls between the cylinder cavities or discharge valve cavity, it may allow the water to flow from one cavity to the adjacent cavity and cause uneven displacement.
8. The holes in the gun or nozzle discs are continually subject to wear because of the high velocity of the liquid through the holes. If the holes become worn, they may allow a higher rate of discharge than the pump is able to provide, then a drop in pressure will be noticed. This can quickly be checked by reducing the number of nozzles or guns while watching the amount of overflow from the pressure regulator. If there is considerable overflow, it is an indication that the regulator valve is worn rather than the gun or nozzle disc.
9. Suction surge arresters should be installed on the suction line of reciprocating pumps, 1-1/2" or 2" can be used. A standing height of 12"-15" will be sufficient with the top end closed by an ordinary pipe cap.
10. Water may accumulate in the pump crankcase from two sources; leakage of the plunger cups or an accumulation of condensation/moisture inside the crankcase due to changes in weather or the repeated heating and cooling of the pump. Pumps used consistently, running for a considerable period of time to heat the oil and other working parts, will not normally accumulate water by condensation. Replace the plunger cups as soon as they start to leak.
11. Worn connecting link bearings are caused by unusual or adverse operating conditions and are seriously affected by corrosion if water is present in the crankcase. They will wear out from overheating if adequate oil is not provided in the crankcase. It is recommended to drain, clean and refill with new oil prior to any storage period. Replace bearings as soon as any damage is discovered to avoid possible damage to crankshaft.
12. Low oil in the crankcase can quickly cause failure of the pump's power end and result in extensive repairs. Oil level should be checked periodically during normal operation and during all maintenance work.
13. A foaming mixture will sometimes have the same effect as a small air leak in the suction line. This is because various quantities of the foam are drawn through the suction line into the pump disrupting the normal flow of water.
14. Pressure regulators and unloading valves may become sluggish in action due to the plunger sticking or fitting too tightly in its cylinder. This may happen by an accumulation of chemicals collecting in and around the plunger or due to excessive corrosion of the plunger parts. To check this condition, remove and clean the plunger and cover the parts with a waterproof grease before assembling.
15. The stuffing box nut on the unloading valve lifting post should not be tightened to severely grip or bind the packing on the post. Tighten this nut just enough to prevent leakage and chatter. The pressure regulator and unloading valves may chatter or vibrate excessively due to an unstable operation from nozzling in the high or low capacity range of the regulator or unloader. The range should be at least 50% to 90% of pump capacity. With unloader valves, nozzle capacity should be at least 20% and not exceed 90% of pump capacity.
16. If foreign matter becomes lodged between the pump valve and valve seat, a drastic drop in capacity and considerable surge or pulsation will occur in the discharge line. Examine each valve if this occurs.
17. When a pump is used for a long period of time, a waterlogged discharge surge could cause pulsation at the discharge. The suction should be opened into the atmosphere to allow air to be drawn through the pump to recharge the surge arrester. Do this with the pressure release valve open so the pump operates at no pressure.
18. Noisy pump operation can be caused by a loose plunger rod in the crosshead. This noise usually has a regular cadence timed with each stroke of the plunger. When this occurs, always replace both the rod and the crosshead.
19. Increased preload to the crankshaft bearings will reduce bearing life, require more power and generate more heat, while insufficient preload may cause a knock, timed with the crankshaft rotation. Check for loose bolts on the crankshaft end caps or adjust shims to obtain proper bearing preload.

MODELS C25-25DV-H/D & C35-20DV-H/D

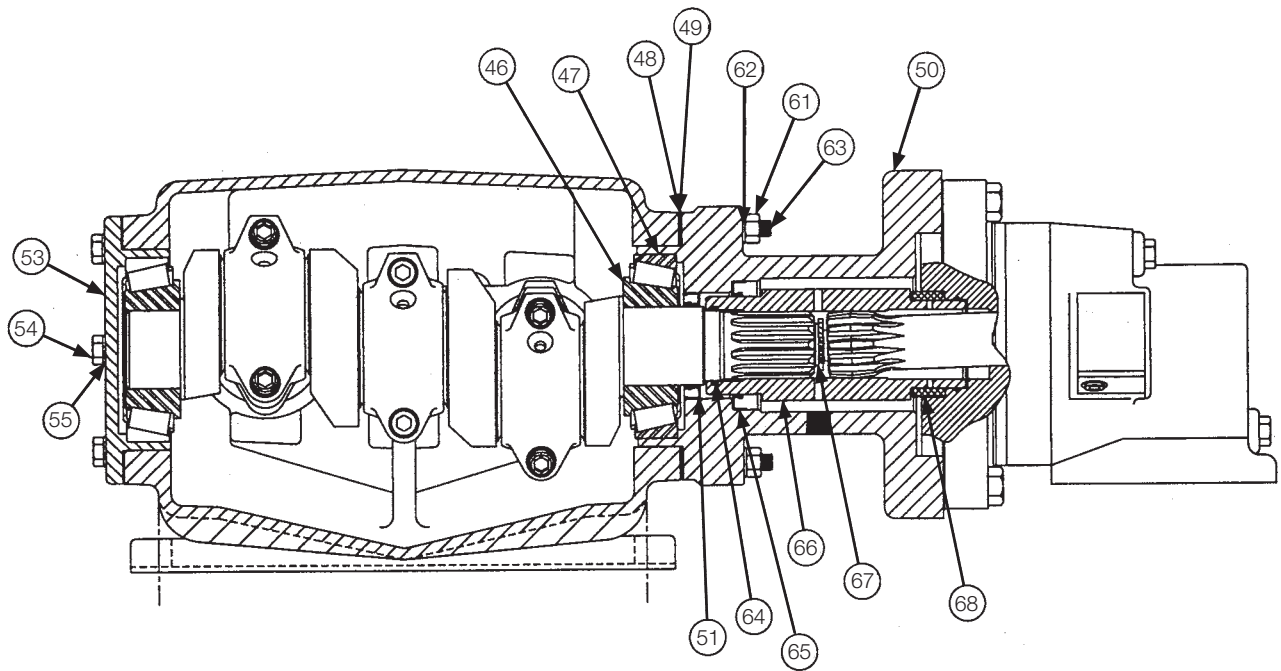
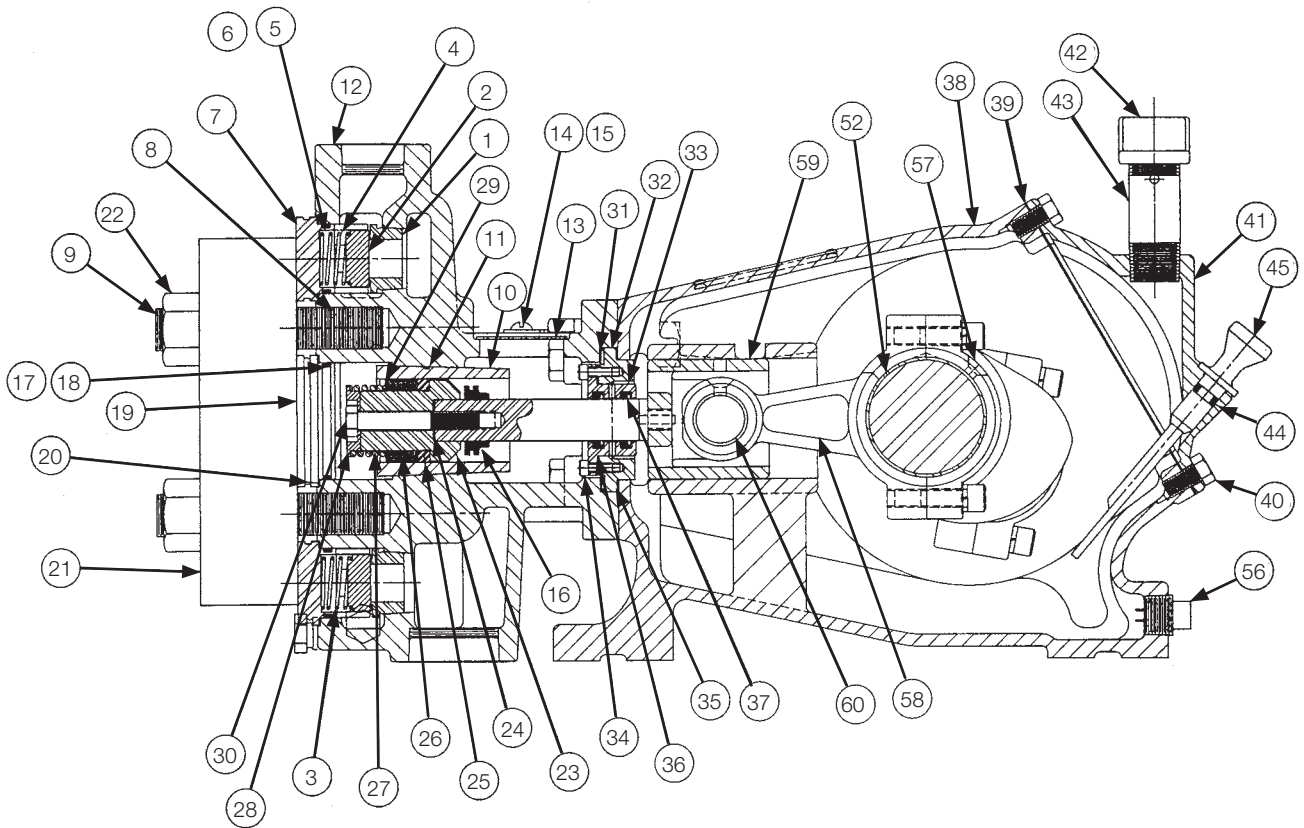

MODELS C25-25DV-H/D & C35-20DV-H/D PARTS LIST

FLUID END

Item	Description	Qty.	Eng. No.
1	SEAT, VALVE	6	06125A002
2	VALVE	6	17714A003
3	SPRING VALVE 31/32 I.D. x 1 LG. x 6 COILS, SUCTION	3	06127A002
4	SPRING VALVE 31/32 I.D. x 1 LG. x 5 COILS, DISCH.	1	06127A003
5	O-RING, 1-7/16 x 1-1/4 x 3/32	6	05876A171
6	RING, BACK-UP, 1-7/16 x 1-1/4	6	18753A008
7	CAP, VALVE 1.858 DIA.	6	18456A006
8	GASKET, NYLON 1.732 x 1.442 x .025	6	05059A436
9	STUD, 7/8-14 UNF x 4-1/2, GR7	6	05659A089
10	LINER, CYLINDER, 1-3/4 I.D., K-RAMIC (C35-20DV-H/D)	3	06124A002
	LINER, CYLINDER, 1-1/2 I.D., K-RAMIC (C25-25DV-H/D)	3	06124A003
11	O-RING, 2-1/4 x 2-1/8 x 1/16	3	05876A172
12	BODY, CYLINDER, C.I.	1	18790E002
13	LID, CYLINDER BODY	1	06123A000
14	SCREW, FOR LID 1/4-20 x 1/2	2	05028A002
15	WASHER, FOR LID	2	05030A020
	CAP SCREW, 1/2 x 1-3/4 LG.	4	19103A008
16	DEFLECTOR, PONY ROD	3	27006A000
	NUT, 5/8-11 UNC	4	19109A041
	WASHER, LOCK	4	05454A011
	BOLT, SQUARE, 5/8-11 x 2-12 LG.	4	19108A027
	PLUG, PIPE 3/8 BR	4	06136A000
17	O-RING, 2-7/16 x 2-1/4 x 3/32	3	05876A173
18	RING, BACK-UP, 2-7/16 x 2-1/4	3	18753A009
19	CAP, CYLINDER, 2-7/8 DIA.	3	18457A005
20	GASKET, NYLON, 2.750 x 2.450 x .025	3	05059A437
21	CLAMP, CYLINDER & VALVE 2" S.Q.	3	20856A001
22	NUT, 7/8-14 UNF	6	19109A072
23	STUD, PISTON 1-3/4 (C35-20DV-H/D)	3	20850A001
	STUD, PISTON 1-1/2 (C25-25DV-H/D)	3	20850A003
24	WASHER, COPPER .593 x .406 x .031	3	05030A128
25	FOLLOWER, ALUM. BRONZE (C35-20DV-H/D)	3	19328A000
	FOLLOWER, ALUM. BRONZE (C25-25DV-H/D)	3	19328A001
26	PACKING, V-RING, 1-3/4 (C35-20DV-H/D)	3	18922A002
	PACKING, V-RING, 1-3/4 (C25-25DV-H/D)	3	18922A008
27	SPRING, PISTON (C35-20DV-H/D)	3	19606A000
	SPRING, PISTON (C25-25DV-H/D)	3	19606A001
28	RETAINER, SPRING	3	27125A000
29	WASHER, 316 SST (C35-20DV-H/D)	3	05030A203
	WASHER, 316 SST (C25-25DV-H/D)	3	05030A246
30	CAP SCREW, NYLON	3	17050A004

POWER END

Item	Description	Qty.	Eng. No.
31	SPRING, RETAINER	3	06120A000
32	RETAINER; OIL SEAL HOUSING	3	24958A001
33	HOUSING, OIL SEAL	3	24959A002
34	SCREW, 10-32 UNF x 1/2	6	06106A034
35	GASKET, VELLUMOID 2-15/16 x 2-1/2 x 1/32	3	05059A052
36	GASKET, VELLUMOID 1.8 x 1.5 x 1/32	3	05059A435
37	CUP, U, 22 I.D. x 30 C.D. x 5.5 LG. WASHER, WEDGE	6 2	22835A004 26709A000
38	CRANKCASE, D.I.	1	06076D000
39	GASKET, VELLUMOID	1	06089B000
40	CAP SCREW, 3/8-16 x 3/4	6	19101A007
41	LID, C.I.	1	06077C000
42	CAP, PIPE	1	05737A021
43	NIPPLE, PIPE 3/4 NPT	1	17995A001
44	O-RING, .574 x .296 x .139	1	05876A235
45	GAUGE, OIL LEVEL	1	17360A014
46	BEARING, CONE, 1.75 BORE	2	05674A019
47	BEARING, CUP, 4.125 O.D.	2	05675A018
48	GASKET, SHIM GREEN - .003"	6	05011A027
49	GASKET, SHIM PINK - .015"	4	05011A028
50	ADAPTER, HYD. DRIVE	1	26599D000
51	SEAL, OIL, 1-3/4 DIA.	1	05710A045
52	CRANKSHAFT	1	06074D014
53	CAP, BEARING, CLOSED	1	10414B001
54	CAP SCREW	12	19101A013
55	WASHER, SEAL	6	14946A003
56	PLUG, DRAIN, 1/2 NPT	1	17481A001
57	BEARING, STEEL BACKED, 2-3/8	6	06109A000
58	LINK, COMPLETE	3	06110B004
59	CROSSHEAD & PISTON ROD BUSHING SCREW, CAP WASHER, LOCK	3 3 6 6	17515B001 06108A000 06106A040 05454A025
60	WRIST PIN	3	06116A000
61	NUT, 3/8-16 UNC	6	19109A017
62	WASHER, LOCK 3/8	6	05454A007
63	STUD, 3/8-16 UNC x 2-5/8	6	05659A128
64	O-RING, 1-3/4 O.D. x 1-9/16 I.D.	1	05876A232
65	SEAL, OIL 2-3/16 DIA.	1	05710A048
66	COUPLING, HYD. DRIVE	1	26602B000
67	VALVE, 1-3/8 DIA.	1	17714A004
68	BEARING, SLEEVE, BRONZE	1	05806A042

C25-25-DV & C35-20-DV PISTON PUMPS PARTS LIST

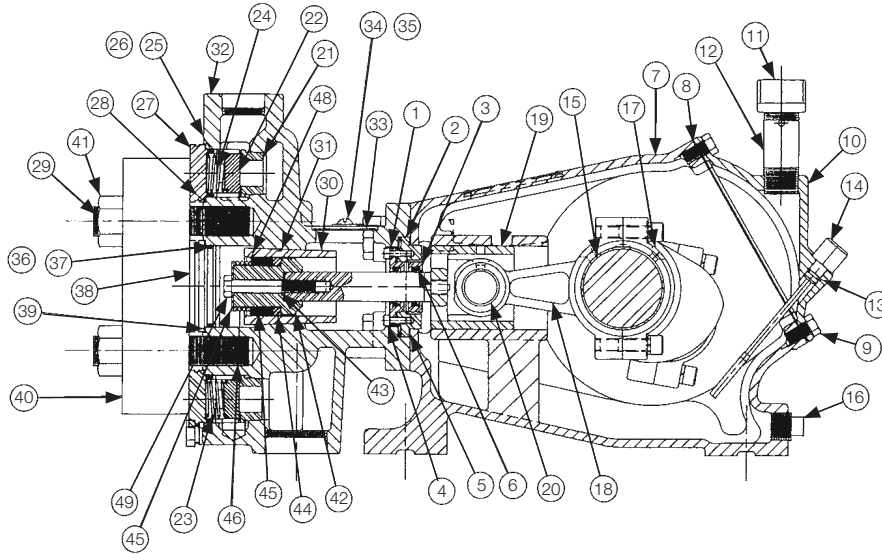

POWER END

Item	Description	Qty.	Eng. No.	
			C35-20DV	C25-25-DV
1	SPRING, RETAINER	3	06120A000	06120A000
2	RETAINER; OIL SEAL HOUSING	3	24958A001	24958A001
3	HOUSING, OIL SEAL	3	24959A002	24959A002
4	SCREW, 10-32 UNF x 1/2	6	06106A034	06106A034
5	GASKET, VELLUMOID 2-15/16 x 2-1/2 x 1/32	3	05059A052	05059A052
6	CUP, U, 22 I.D. x 30 C.D. x 5.5 LG.	6	22835A004	22835A004
7	CRANKCASE, D.I.	1	06076D000	06076D000
8	GASKET, VELLUMOID	1	06089B000	06089B000
9	CAP SCREW, 3/8-16 x 3/4	6	19101A007	19101A007
10	LID, C.I.	1	06077C000	06077C000
11	CAP, PIPE	1	05737A021	05737A021
12	NIPPLE, PIPE 3/4 NPT	1	17995A001	17995A001
13	O-RING, 3/8 x 9/16 x 1/16	1	110-000110-201	110-000110-201
14	GAUGE, OIL LEVEL	1	17360A014	17360A014
	BEARING, CONE, 1.75 BORE	2	05674A019	05674A019
	BEARING, CUP, 4.125 O.D.	2	05675A018	05675A018
	GASKET, SHIM GREEN - .003"	6	05011A027	05011A027
	GASKET, SHIM PINK - .015"	4	05011A028	05011A028
	CAP, BEARING, OPEN	1	10414B002	10414B002
	WASHER, SEAL	12	14946A003	14946A003
	SEAL, OIL, 1-3/4 DIA.	1	05710A004	05710A004
15	CRANKSHAFT	1	06074D011	06074D011
	CAP, BEARING, CLOSED	1	10414B001	10414B001
	CAP SCREW	12	19101A013	19101A013
16	PLUG, DRAIN, 1/2 NPT	1	17481A001	17481A001
17	BEARING, STEEL BACKED, 2-3/8	6	06109A000	06109A000
18	LINK, COMPLETE	3	06110B004	06110B004
	SCREW, CAP, SOCKET HEAD	3	06106A040	06106A040
	WASHER, LOCK	3	05454A025	05454A025
19	CROSSHEAD & PISTON ROD	3	17515B001	17515B001
	WRIST PIN	3	06116A000	06116A000
20	BUSHING	3	06108A000	06108A000

FLUID END

Item	Description	Qty.	Eng. No.	
			C35-20DV	C25-25-DV
21	SEAT, VALVE	6	06125A002	06125A002
22	VALVE	6	17714A003	17714A003
23	SPRING VALVE 31/32 I.D. x 1 LG. x 6 COILS, SUCTION	3	06127A002	06127A002
24	SPRING VALVE 31/32 I.D. x 1 LG. x 5 COILS, DISCH.	3	06127A003	06127A003
25	O-RING, 1-7/16 x 1-1/4 x 3/32	6	05876A171	05876A171
26	RING, BACK-UP, 1-7/16 x 1-1/4	6	18753A008	18753A008
27	CAP, VALVE 1.858 DIA.	6	18456A006	18456A006
28	GASKET, NYLON 1.732 x 1.442 x .025	6	05059A436	05059A436
29	STUD, 7/8-14 UNF x 4-1/2, GR7	6	05659A089	05659A089
30	LINER, CYLINDER, 1-3/4 I.D., K-RAMIC	3	06124A002	—
	LINER, CYLINDER, 1-1/2 I.D., K-RAMIC	3	—	06124A003
31	O-RING, 2-1/4 x 2-1/8 x 1/16	3	05876A172	05876A172
32	BODY, CYLINDER, C.I.	1	18790E002	18790E002
33	LID, CYLINDER BODY	1	06123A000	06123A000
34	SCREW, FOR LID 1/4-20 x 1/2	2	05028A002	05028A002
35	WASHER FOR LID	2	05030A020	05030A020
	CAP SCREW, 1/2 x 1-3/4 LG.	4	19103A008	19103A008
	WASHER, LOCK 5/8	4	05454A011	05454A011
	BOLT, SQUARE, 5/8-11 x 2-1/2 LG.	4	19108A027	19108A027
	NUT, 5/8-11	4	19109A041	19109A041
	PLUG, PIPE 3/8 BR	4	06136A000	06136A000
36	O-RING, 2-7/16 x 2-1/4 x 3/32	3	05876A173	05876A173
37	RING, BACK-UP, 2-7/16 x 2-1/4	3	18753A009	18753A009
38	CAP, CYLINDER, 2-7/8 DIA.	3	18457A005	18457A005
39	GASKET, NYLON, 2.750 x 2.450 x .025	3	05059A437	05059A437
40	CLAMP, CYLINDER & VALVE 2" S.Q.	3	20856A001	20856A001
41	NUT, 7/8-14 UNF	6	19109A072	19109A072
42	STUD, PISTON 1-3/4	3	20850A001	—
	STUD, PISTON 1-1/2	—	20850A003	—
43	WASHER, COPPER .593 x .406 x .031	3	05030A128	05030A128
44	FOLLOWER, BRASS	3	19328A000	19328A001
45	PACKING, V-RING, 1-3/4	3	18922A002	—
	PACKING, V-RING, 1-1/2	3	—	18922A008
46	SPRING, PISTON	3	19606A000	19606A001
47	WASHER, 316 SST	3	05030A205	05030A247
48	WASHER, 316 SST	3	05030A203	05030A246
49	CAP SCREW, NYLOK®	3	17050A004	17050A004
	VALVE SEAT REMOVAL TOOL KIT	1	07294A000	07294A000
	RECOMMENDED PRESSURE REGULATOR	1	15696C005K	15696C005K

C35-20B PISTON PUMPS PARTS LIST

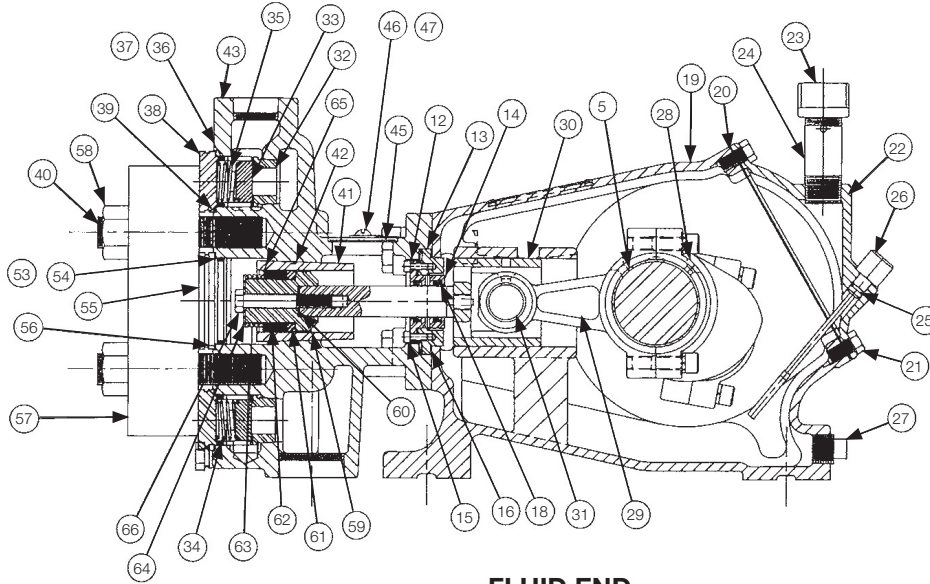

POWER END

Item	Description	Qty.	Eng. No.
			C35-20B
1	WASHER, SEAL	12	14946A003
2	CAP SCREW	12	19101A009
3	O-RING, 4-3/8 O.D.	2	05876A240
4	KEY, SQUARE	1	05818A077
5	CRANKSHAFT	1	06074D011
6	SEAL, OIL, 1-3/8 DIA.	1	05710A004
7	CAP, BEARING, OPEN	1	10414B002
8	GASKET, SHIM, GREEN - .003	6	05011A027
9	BEARING, CUP, 4.125 O.D.	2	05675A018
10	BEARING, CONE, 1.75 BORE	2	05674A019
11	CAP, BEARING, CLOSED	1	10414B001
12	SPRING, RETAINER	3	06120A000
13	RETAINER, OIL SEAL HOUSING	3	24958A001
14	HOUSING, OIL SEAL	3	24959A002
15	SCREW, 10-32 UNF x 1/2	6	06106A034
16	GASKET, VELLUMOID 2-15/16 x 2-1/2 x 1/32	3	05059A052
17	GASKET, VELLUMOID 1.8 x 1.5 x 1/32	3	05059A435
18	CUP, U, 22 I.D. x 30 C.D. x 5.5 IG.	6	22835A004
19	CRANKCASE, D.I.	1	06076D000
20	GASKET, VELLUMOID	1	06089B000
21	CAP SCREW, 3/8-16 x 7/8	6	19101A008
22	LID C.I.	1	06077C000
23	CAP, PIPE	1	05737A021
24	NIPPLE, PIPE 3/4 NPT	1	17995A001
25	O-RING, 3/8 x 9/16 x 1/16	1	110-000110-201
26	GAUGE, OIL LEVEL	1	17360A014
27	PLUG, DRAIN, 1/2 NPT	1	17481A001
28	BEARING, STEEL BACKED, 2-3/8	6	06109A000
29	LINK, COMPLETE	3	06110B004
30	CROSSHEAD & PISTON ROD	3	17515B001
31	WRIST PIN	3	06116A000
32	BUSHING	3	06108A000
33	SEAT, VALVE	6	06125A002
33	VALVE - SST 440C	6	17714A004

FLUID END

Item	Description	Qty.	Eng. No.
			C35-20B
34	SPRING VALVE 31/32 J.D. x 1 LG. x 6 COILS, SUCTION	3	06127A002
35	SPRING VALVE 31/32 J.D. x 1 LG. x 5 COILS, DISCH.	3	06127A003
36	O-RING, 1-7/16 x 1-1/4 x 3/32	6	05876A171
37	RING, BACK-UP, 1-7/16 x 1-1/4	6	18753A008
38	CAP, VALVE 1.858 DIA.	6	18456A005
39	GASKET, NYLON 1.732 x 1.442 x .025	6	05059A436
40	STUD, 7/8-14 UNF x 4-1/2, GR7	6	05659A131
41	LINER, CYL., 1-3/4 I.D., K-RAMIC	3	06124A002
42	O-RING, 2-1/4 x 2/18 x 1/16	3	05876A172
43	BODY, CYLINDER, C.I.	1	18790E002
44	GASKET, SHIM, PINK - .015"	4	05011A028
45	LID, CYLINDER BODY	1	06123A000
46	SCREW FOR LID 1/4-20 x 1/2	2	05028A002
47	WASHER FOR LID	2	05030A020
48	CAP SCREW, 1/2 x 1-3/4 LG.	4	19103A008
49	WASHER, LOCK 5/8	4	05454A011
50	BOLT, SQUARE, 5/8-11 x 2-1/2 LG.	4	19108A027
51	NUT, 5/8-11	4	19109A041
52	PLUG, PIPE 3/8 BR	4	06136A000
53	O-RING, 2-7/16 x 2-1/4 x 3/32	3	05876A173
54	RING, BACK-UP, 2-7/16 x 2-1/4	3	18753A009
55	CAP, CYLINDER, 2-7/8 DIA.	3	18457A005
56	GASKET, NYLON, 2.750 x 2.450 x .025	3	05059A437
57	CLAMP, CYLINDER & VALVE 2" S.Q.	3	20856A001
58	NUT, 7/8-14 UNF	6	19109A072
59	STUD, PISTON 1-3/4	3	20850A001
60	WASHER, COPPER .593 x .406 x .031	3	05030A128
61	FOLLOWER, BRASS	3	19328A000
62	PACKING, V-RING, 1-3/4	3	18922A002
63	SPRING, PISTON	3	19606A000
64	WASHER, 316 SST	3	05030A205
65	WASHER, 316 SST	3	05030A203
66	CAP SCREW, NYLOK® VALVE SEAT REMOVAL TOOL KIT	3 1	17050A004 07294A000

MODEL C40-20

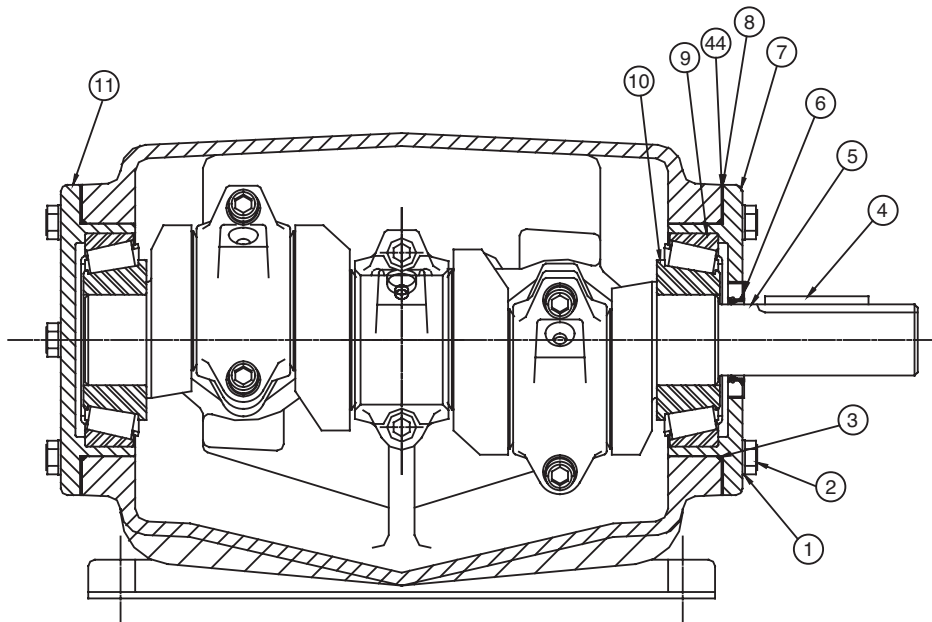
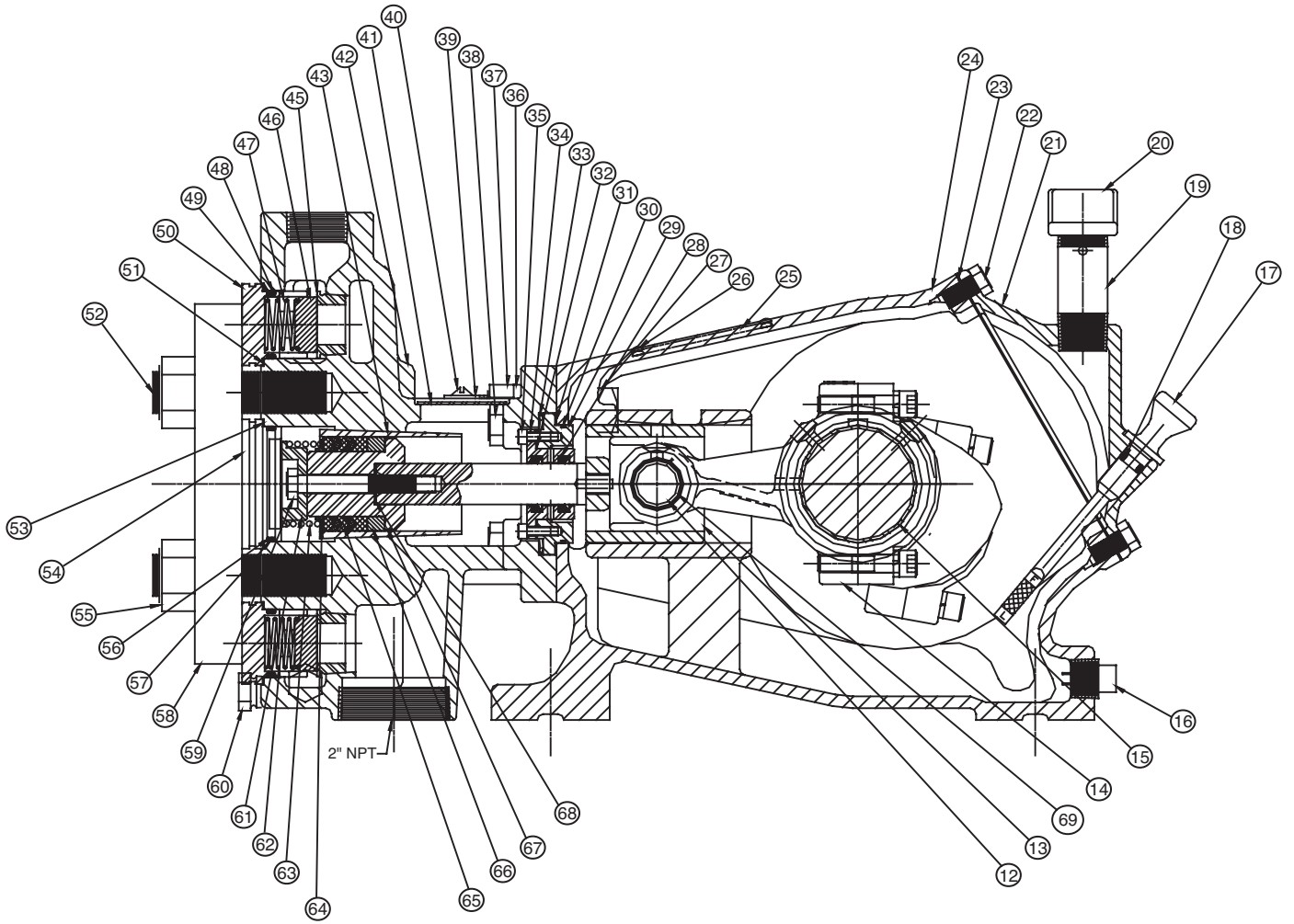

MODEL C40-20 PARTS LIST

Item	Description	Qty.	Eng. No.
1	WASHER, SEAL	12	14946A003
2	SCREW, CAP, 3/8-16	12	19101A013
3	O-RING, 4-3/8 O.D.	2	05876A240
4	KEY, SQUARE, 5/16 x 5/16	1	05818A077
5	CRANKSHAFT	1	06074D016
6	SEAL, OIL, 1-3/8 SHAFT	1	05710A004
7	CAP, BEARING, OPEN	1	10414B002
8	GASKET, SHIM, .003", GREEN	6	05011A027
9	BEARING, CUP	2	05675A018
10	BEARING, CONE	2	05674A019
11	CAP, BEARING, CLOSED	1	10414B001
12	PIN, WRIST	3	06116A000
13	CROSSHEAD & PISTON ROD	3	17515B001
14	LINK	3	27300B000
15*	BEARING, STEEL-BACKED HALF	6	06109A000
16	PLUG, PIPE, MAGNETIC	1	17481A001
17	GAUGE, OIL LEVEL	1	17360A014
18	O-RING	1	110-000110-201
19	NIPPLE, PIPE	1	17995A001
20	CAP, PIPE	1	05737A021
21	LID	1	06077C000
22	SCREW, CAP, HEX, 3/8-16	6	19101A007
23	GASKET	1	06089B000
24	CASE, GEAR	1	06076D000
25	PLATE, NAME	1	06008A374
26	SCREW, DRIVE	4	05160A004
27	BOLT, SQUARE, 5/8-11	4	19108A027
28	U-CUP	6	22835A004
29	RETAINER, OIL SEAL HOUSING	3	24958A001
30	O-RING, 2-1/2 O.D.	3	05876A224
31	GASKET, VELLUMOID, 2-15/16 O.D.	3	05059A052
32	GASKET, VELLUMOID, 1.80 O.D.	3	05059A435
33	SPRING, RETAINER	3	06120A000
34	HOUSING, OIL SEAL	3	24959A002

* Undersized (.030 dia.) Bearings are 10877A010K (2 Halves).

Item	Description	Qty.	Eng. No.
35	SCREW, CAP, SOCKET HEAD	6	06106A034
36	WASHER, LOCK, 1/4"	4	05454A011
37	NUT, HEX, 5/8-11	4	19109A041
38	SCREW, CAP, HEX, 1/2-13	4	19103A008
39	WASHER, 5/16 I.D.	2	05030A020
40	SCREW, MACHINE, 1/4-20	2	05028A002
41	LID, BODY, CYLINDER	1	06123A000
42	BODY, CYLINDER	1	18790E006
43	LINER, CYLINDER, 2.00 I.D.	3	06124A004
44	GASKET, SHIM, .005", PINK	4	05011A028
45	SEAT, VALVE	6	06125A004
46	VALVE, DELRIN®	6	17714A003
47	SPRING, VALVE, DISCHARGE	3	06127A003
48	O-RING, 1 7/16 O.D.	6	05876A171
49	RING, BACK-UP, NITRILE	6	18753A008
50	CAP, VALVE	6	18456A007
51	GASKET, NYLON	6	05059A436
52	STUD, 7/8-14UNF	6	05659A130
53	GASKET, NYLON	3	05059A437
54	CAP, SST CYLINDER	3	18457A008
55	NUT, HEX ST 7/8-14 NF	6	19109A072
56	RING, BACK-UP, NITRILE	3	18753A009
57	O-RING, 2 7/16 O.D.	3	05876A173
58	PLATE, STEEL	1	26980B000
59	SCREW, CAP, HEX, NYLOK®	3	17050A004
60	PLUG, PIPE, BRASS 3/8" NPT	4	06136A000
61	RETAINER, SPRING, SST	3	18879A004
62	SPRING, VALVE, SUCTION	3	06127A002
63	SPRING, SST	3	18920A000
64	RING, PRESSURE, SST	3	18921A000
65	PACKING, V-RING, 2.00 O.D.	3	18922A000
66	FOLLOWER, BRASS	3	18923A002
67	STUD, PISTON	3	20850A004
68	WASHER, COPPER	3	05030A128
69	BUSHING	3	06108B000K

STANDARD LIMITED WARRANTY CENTRIFUGAL & RECIPROCATING PUMPS

Pentair Myers® warrants its products against defects in material and workmanship for a period of 12 months from the date of shipment from Pentair Myers or 18 months from the manufacturing date, whichever occurs first – provided that such products are used in compliance with the requirements of the Pentair Myers catalog and technical manuals.

During the warranty period and subject to the conditions set forth, Pentair Myers, at its discretion, will repair or replace to the original user, the parts that prove defective in materials and workmanship. Pentair Myers reserves the right to change or improve its products or any portions thereof without being obligated to provide such a change or improvement for prior sold and/or shipped units.

Seals, piston cups, packing, plungers, liners and valves used for handling clear, fresh, nonaerated water at a temperature not exceeding 120°F are warranted for ninety days from date of shipment. All other applications are subject to a thirty day warranty. Accessories such as motors, engines and auxiliary equipment are warranted by the respective manufacturer and are excluded in this standard warranty. Under no circumstance will Pentair Myers be responsible for the cost of field labor, travel expenses, rented equipment, removal/reinstallation costs or freight expenses to and from the factory or an authorized Pentair Myers service facility.

This limited warranty will not apply: (a) to defects or malfunctions resulting from failure to properly install, operate or maintain the unit in accordance with the printed instructions provided; (b) to failures resulting from abuse, accident or negligence; (c) to normal maintenance services and parts used in connection with such service; (d) to units that are not installed in accordance with applicable local codes, ordinances and good trade practices; (e) if the unit is moved from its original installation location; (f) if unit is used for purposes other than for what it is designed and manufactured; (g) to any unit that has been repaired or altered by anyone other than Pentair Myers or an authorized Pentair Myers service provider; (h) to any unit that has been repaired using non factory specified/OEM parts.

Warranty Exclusions: PENTAIR MYERS MAKES NO EXPRESS OR IMPLIED WARRANTIES THAT EXTEND BEYOND THE DESCRIPTION ON THE FACE HEREOF. PENTAIR MYERS SPECIFICALLY DISCLAIMS THE IMPLIED WARRANTIES OF MERCHANTABILITY AND FITNESS FOR ANY PARTICULAR PURPOSE.

Liability Limitation: IN NO EVENT SHALL PENTAIR MYERS BE LIABLE OR RESPONSIBLE FOR CONSEQUENTIAL, INCIDENTAL OR SPECIAL DAMAGES RESULTING FROM OR RELATED IN ANY MANNER TO ANY PENTAIR MYERS PRODUCT OR PARTS THEREOF. PERSONAL INJURY AND/OR PROPERTY DAMAGE MAY RESULT FROM IMPROPER INSTALLATION. PENTAIR MYERS DISCLAIMS ALL LIABILITY, INCLUDING LIABILITY UNDER THIS WARRANTY, FOR IMPROPER INSTALLATION. PENTAIR MYERS RECOMMENDS INSTALLATION BY PROFESSIONALS.

Some states do not permit some or all of the above warranty limitations or the exclusion or limitation of incidental or consequential damages and therefore such limitations may not apply to you. No warranties or representations at any time made by any representatives of Pentair Myers shall vary or expand the provision hereof.



MYERS®
MYERS® APLEX SERIES

1101 MYERS PARKWAY
ASHLAND, OHIO, USA 44805
419-289-1144

WWW.FEMYERS.COM

Warranty Rev. 12/13