

# Keysight 16197A Bottom Electrode SMD Test Fixture

Operation and  
Service Manual



NOTICE: This document contains references to Agilent Technologies. Agilent's former Test and Measurement business has become Keysight Technologies. For more information, go to [www.keysight.com](http://www.keysight.com).



---

## Notices

The information contained in this document is subject to change without notice.

This document contains proprietary information that is protected by copyright. All rights are reserved. No part of this document may be photocopied, reproduced, or translated to another language without the prior written consent of the Keysight Technologies.

© Copyright 2001, 2008, 2011, 2015 Keysight Technologies

---

## Manual Printing History

The manual's printing date and part number indicate its current edition. The printing date changes when a new edition is printed. (Minor corrections and updates that are incorporated at reprint do not cause the date to change.) The manual part number changes when extensive technical changes are incorporated.

January 2001	Edition 1 (part number: 16197-90000)
September 2008	Edition 2 (part number: 16197-90010)
September 2011	Edition 3 (part number: 16197-90020)
February 2015	Edition 4

---

## Safety Summary

The following general safety precautions must be observed during all phases of operation, service, and repair of this instrument. Failure to comply with these precautions or with specific WARNINGS elsewhere in this manual may impair the protection provided by the equipment. In addition it violates safety standards of design, manufacture, and intended use of the instrument.

Keysight Technologies assumes no liability for the customer's failure to comply with these requirements.

---

### NOTE

16197A comply with INSTALLATION CATEGORY I and POLLUTION DEGREE 2 in IEC61010-1. 16197A are INDOOR USE product.

- Ground The Instrument

To avoid electric shock hazard, the instrument chassis and cabinet must be connected to a safety earth ground by the supplied power cable with earth blade.

- DO NOT Operate In An Explosive Atmosphere

Do not operate the instrument in the presence of flammable gasses or fumes. Operation of any electrical instrument in such an environment constitutes a definite safety hazard.

- Keep Away From Live Circuits

Operating personnel must not remove instrument covers. Component replacement and internal adjustments must be made by qualified maintenance personnel. Do not replace components with the power cable connected. Under certain conditions, dangerous voltages may exist even with the power cable removed. To avoid injuries, always disconnect power and discharge circuits before touching them.

- DO NOT Service Or Adjust Alone

Do not attempt internal service or adjustment unless another person, capable of rendering first aid and resuscitation, is present.

- DO NOT Substitute Parts Or Modify Instrument

Because of the danger of introducing additional hazards, do not install substitute parts or perform unauthorized modifications to the instrument. Return the instrument to a Keysight Technologies Sales and Service Office for service and repair to ensure that safety features are maintained.

- Dangerous Procedure Warnings

Warnings, such as the example below, precede potentially dangerous procedures throughout this manual. Instructions contained in the warnings must be followed.

---

**WARNING**

---

**Dangerous voltages, capable of causing death, are presenting this instrument. Use extreme caution when handling, testing, and adjusting this instrument.**

---

## Safety Symbol

General definitions of safety symbols used on the instrument or in manuals are listed below.



Instruction Manual symbol: the product is marked with this symbol when it is necessary for the user to refer to the instrument manual.



Alternating current.



Direct current.



On (Supply).



Off (Supply).



In position of push-button switch.



Out position of push-button switch.



Frame (or chassis) terminal. A connection to the frame (chassis) of the equipment which normally include all exposed metal structure.

---

**WARNING**

---

**This warning sign denotes a hazard. It calls attention to a procedure, practice, condition or the like, which, if not correctly performed or adhered to, could result in injury or death to personnel.**

---

**CAUTION**

This Caution sign denotes a hazard. It calls attention to a procedure, practice, condition or the like, which, if not correctly performed or adhered to, could result in damage to or destruction of part or all of the product.

---

**NOTE**

Note denotes important information. It calls attention to a procedure, practice, condition or the like, which is essential to highlight.

---

---

## Certification

Keysight Technologies certifies that this product met its published specifications at the time of shipment from the factory. Keysight Technologies further certifies that its calibration measurements are traceable to the United States National Institute of Standards and Technology, to the extent allowed by the Institution's calibration facility, or to the calibration facilities of other International Standards Organization members.

---

## Warranty

This Keysight Technologies instrument product is warranted against defects in material and workmanship for a period corresponding to the individual warranty periods of its component products. Instruments are warranted for a period of one year. Fixtures and adapters are warranted for a period of 90 days. During the warranty period, Keysight Technologies Company will, at its option, either repair or replace products that prove to be defective.

For warranty service or repair, this product must be returned to a service facility designated by Keysight Technologies. Buyer shall prepay shipping charges to Keysight Technologies and Keysight Technologies shall pay shipping charges to return the product to Buyer. However, Buyer shall pay all shipping charges, duties, and taxes for products returned to Keysight Technologies from another country.

Keysight Technologies warrants that its software and firmware designated by Keysight Technologies for use with an instrument will execute its programming instruction when properly installed on that instrument. Keysight Technologies does not warrant that the operation of the instrument, or software, or firmware will be uninterrupted or error free.

---

## Limitation of Warranty

The foregoing warranty shall not apply to defects resulting from improper or inadequate maintenance by Buyer, Buyer-supplied software or interfacing, unauthorized modification or misuse, operation outside the environmental specifications for the product, or improper site preparation or maintenance.

---

---

**IMPORTANT**

---

No other warranty is expressed or implied. Keysight Technologies specifically disclaims the implied warranties of merchantability and fitness for a particular purpose.

---

## Exclusive Remedies

The remedies provided herein are buyer's sole and exclusive remedies. Keysight Technologies shall not be liable for any direct, indirect, special, incidental, or consequential damages, whether based on contract, tort, or any other legal theory.

---

## Assistance

Product maintenance agreements and other customer assistance agreements are available for Keysight Technologies products.

For any assistance, contact your nearest Keysight Technologies Sales and Service Office. Addresses are provided at the back of this manual.

---

## Typeface Conventions

<b>Bold</b>	Boldface type is used when a term is defined. For example: <b>icons</b> are symbols.
<i>Italic</i>	Italic type is used for emphasis and for titles of manuals and other publications.
<b>[Hardkey]</b>	Indicates a hardkey labeled "Hardkey."
<b>Softkey</b>	Indicates a softkey labeled "Softkey."
<b>[Hardkey] - Softkey1 - Softkey2</b>	Indicates keystrokes <b>[Hardkey] - Softkey1 - Softkey2</b> .





<b>1. Installation Guide</b>	
Inspection before Unpacking	10
Assembly and Storage of 16197A	13
Assembly of 16197A	13
Storage	15
Changing the Positions of the Guide Holder Fixing Screws	16
Method for Changing the Positions of the Guide Holder Fixing Screws	16
Connecting the Test Fixture with a Measuring Instrument	18
<b>2. Product Description</b>	
Product Description	22
Mechanism for Connecting a DUT (Device Under Test)	23
Names & Functions of Parts	25
Names & Functions of Accessories	26
<b>3. Operation</b>	
Measurement Flow	30
Setting the Electrical Length	32
Changing the Orientation of the Device Guide and Electrode Plate	33
Selecting the device guide frame	33
Changing the Orientation of or Replacing the Device Guide and Electrode Plate	35
Working with the Device Guide	39
Reference Data for Preparing a Device Guide Frame	39
Example of Preparing the Device Guide	40
Example of Preparing a Simple Device Guide	42
Performing Fixture Compensation	43
Measuring the SHORT Compensation Data	43
Measuring the OPEN Compensation Data	47
Connecting and Measuring the DUT	48
<b>4. User Maintenance</b>	
Description	52
Necessity of User Maintenance	52
Cleaning	54
Areas Requiring Cleaning	54
Cleaning Method	54
Deterioration Check	56
Example Settings of User Limit Values	56
Acquiring Reference Values	57
Electrode Deterioration Check	57
Check Sheet	59
Example Entry in Check Sheet	59
Electrode Deterioration Check	60
Assembly Check	62
<b>5. Specifications and Supplemental Performance Characteristics</b>	
Definitions	64
Specifications	65

---

# Contents

Supplemental Performance Characteristics .....	66
Additional Error .....	66
Residual Inductance of the Shorting Bar .....	68
<b>6. Service</b>	
Replaceable Parts .....	70
Pressure Unit .....	70
Electrode Unit .....	72
Other Parts .....	73
Changing the Orientation of or Replacing the Contact Assembly .....	74
Procedure for Changing the Orientation of or Replacing the Contact Assembly .....	74
Operation Check .....	76
Open Impedance Check .....	76
Short Impedance Check .....	77
Short-impedance Measurement Repeatability Check .....	77
<b>A. Manual Changes</b>	
Manual Changes .....	80

---

# 1

## Installation Guide

This chapter describes the necessary operations to perform before using the delivered bottom-electrode SMD test fixture 16197A.

## **Inspection before Unpacking**

Upon receiving the product package, inspect the packing box before unpacking to make sure it is not damaged. If the packing box or packing materials have been damaged, keep the box and materials until it has been confirmed that all necessary components have been delivered and that product operation is normal both mechanically and electrically.

Check the package contents against [Table 1-1](#). If any component is missing, or mechanically damaged or defective, please contact Keysight Technologies local sales office. If the packing box has been damaged or the packing materials have been severely deformed, please contact the freight company as well as our sales office. Until the freight company carries out its inspection, store the packing box and materials as they are, with all product components left inside.

---

### **NOTE**

Before using this product for the first time after delivery, carry out “[Deterioration Check](#)” on [page 56](#), which is necessary to ensure accurate measurement. For details, see “[Acquiring Reference Values](#)” on [page 57](#) of the “[Deterioration Check](#)” section.

**Figure 1-1 Package Contents of 16197A**

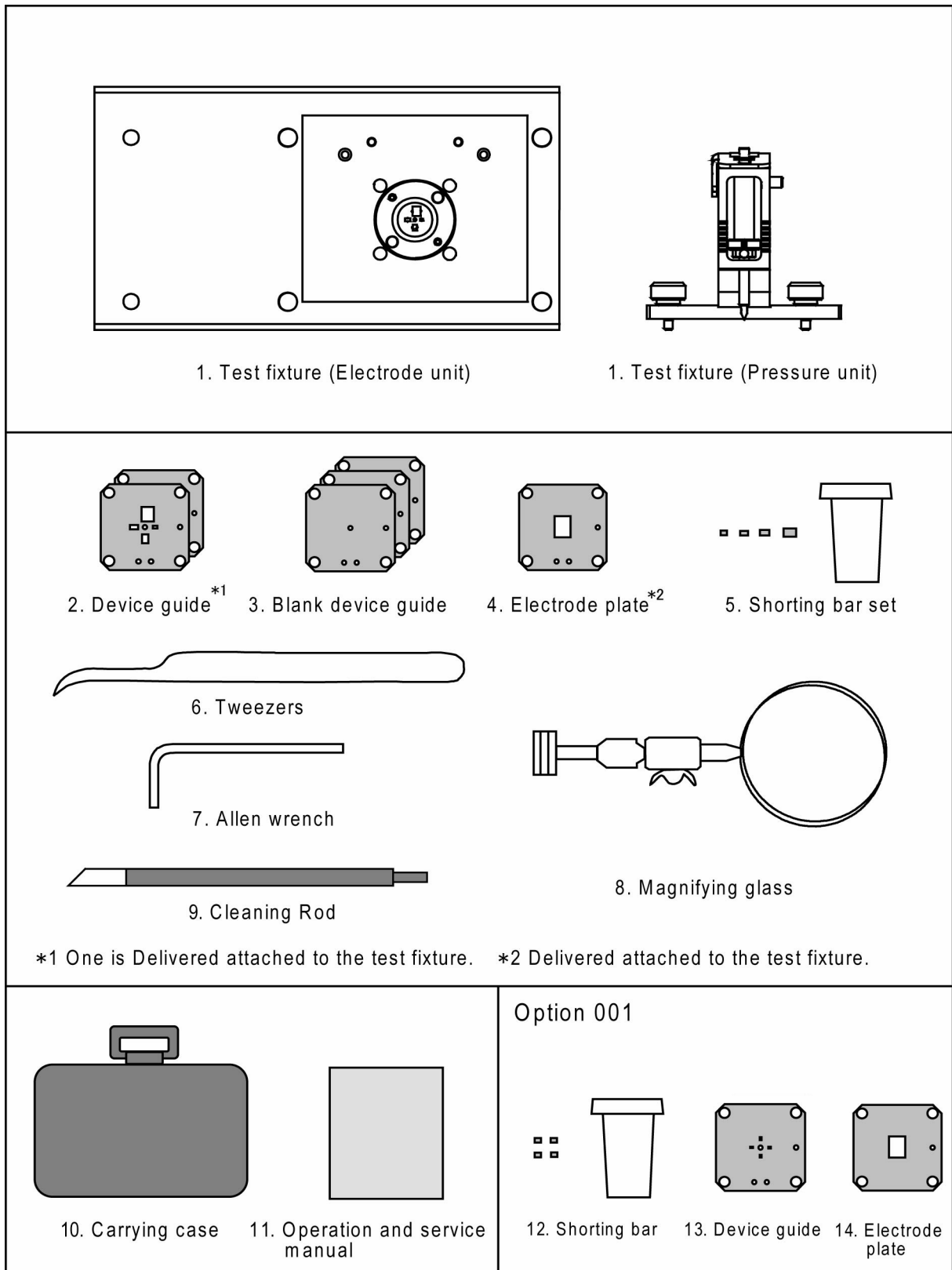

16197a0e0501

Installation Guide  
**Inspection before Unpacking**

**Table 1-1 Package Contents of 16197A**

No.	Name	Keysight part number	Qty
1	Bottom-electrode SMD test fixture 16197A	-	1
2	Device guide* <sup>1</sup>	16197-25005	2
3	Blank device guide	16197-25006	3
4	Electrode plate* <sup>2</sup>	16197-00603	1
5	EIA/EIAJ -size, Shorting bar set		
	Shorting bar 1.0 × 0.5 × 0.5* <sup>3</sup>	16191-29005	1
	Shorting bar 1.6 × 0.8 × 0.8* <sup>3</sup>	16191-29006	1
	Shorting bar 2.0 × 1.2 × 0.8* <sup>3</sup>	16191-29007	1
	Shorting bar 3.2 × 1.6 × 0.8* <sup>3</sup>	16191-29008	1
6	Tweezers	8710-2081	1
7	Allen wrench	8710-0909	1
8	Magnifying glass	16193-60002	1
9	Cleaning rod	5182-7586	1
10	Carrying case	16197-60050	1
11	Operation and service manual (this manual)	16197-90020	1
Option 001			
12	Shorting bar 0.6 × 0.3 × 0.3	16197-29001	4
13	Device guide	16197-25007	1
14	Electrode plate	16197-00604	1

\*1. One is Delivered attached to the test fixture

\*2. Delivered attached to the test fixture

\*3. Shorting bars are delivered together in one case.

## Assembly and Storage of 16197A

The 16197A is delivered in a carrying case, disassembled into a pressure unit and an electrode unit. Assemble the fixture before use. Disassemble the fixture when storing it in the carrying case.

### Assembly of 16197A

Before using the 16197A, install the pressure unit onto the electrode unit as shown in [Figure 1-2](#).

**Figure 1-2** Installing the Pressure Unit

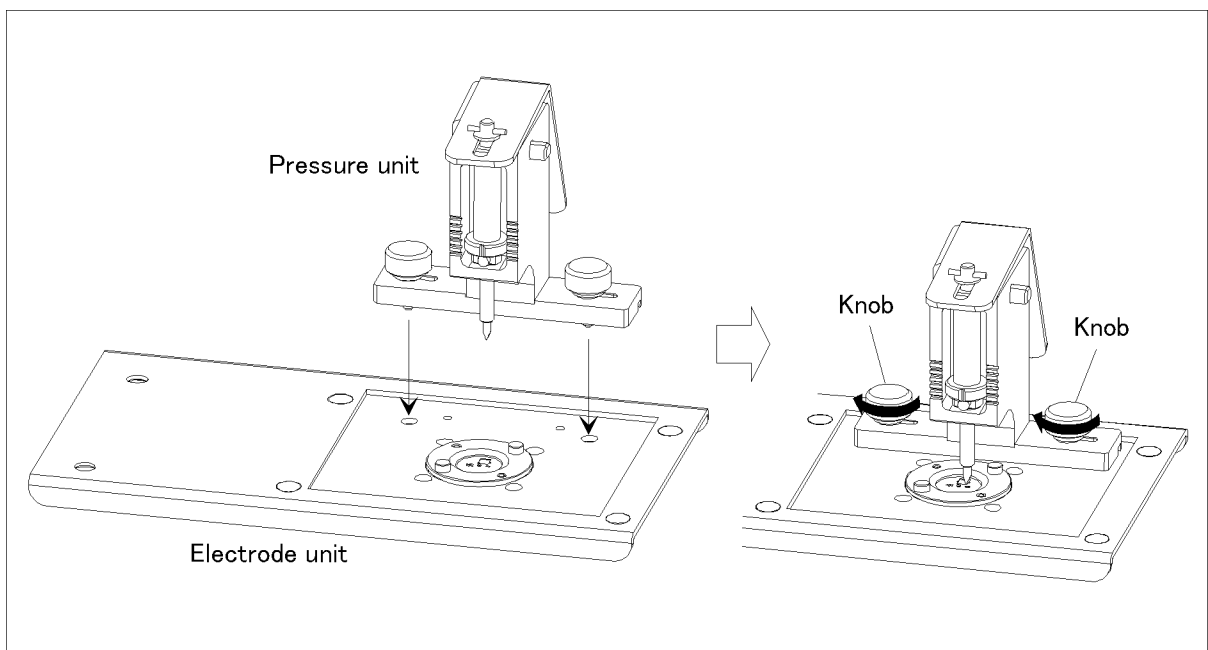

**Installing the Magnifying Glass**

If the magnifying glass is used, install it on the edge of the electrode unit as shown in [Figure 1-3](#).

**Figure 1-3**      **Installing the Magnifying Glass**

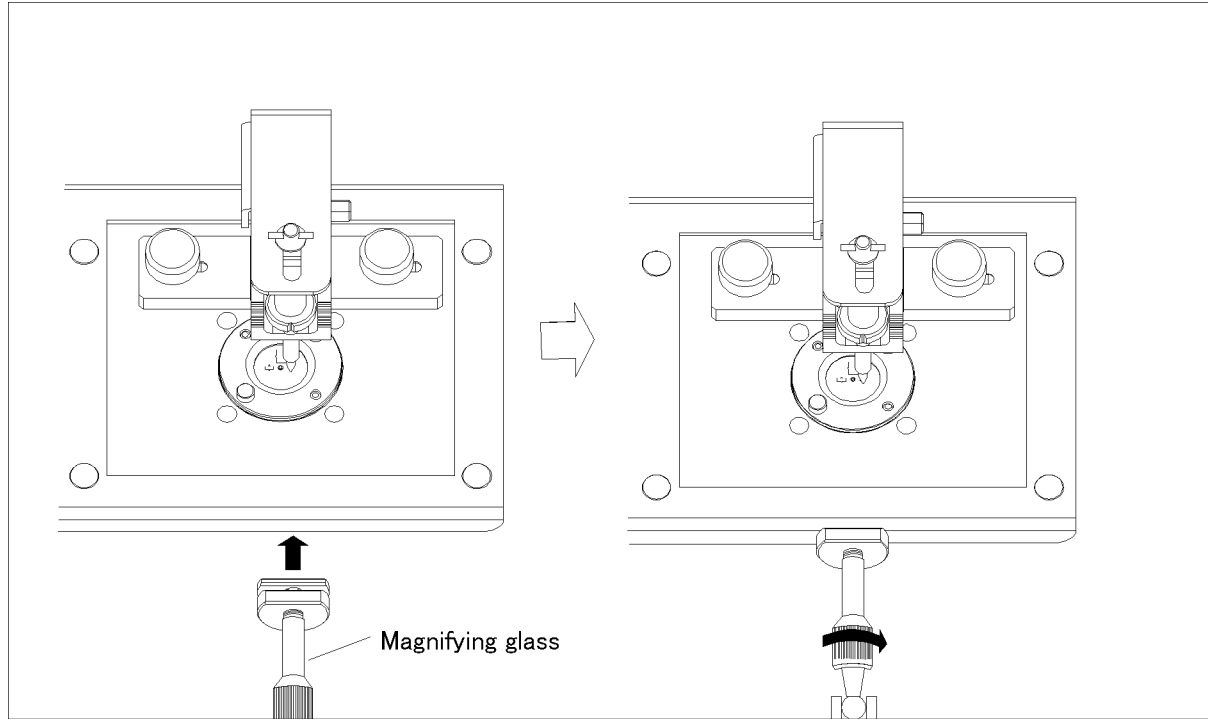



**Storage**

Before storing the 16197A, remove the pressure unit from the electrode unit (Figure 1-4), and loosen the pressure adjusting nut on the pressure unit (Figure 1-5). Also remove the magnifying glass, if installed.

**Figure 1-4** Removing the Pressure Unit

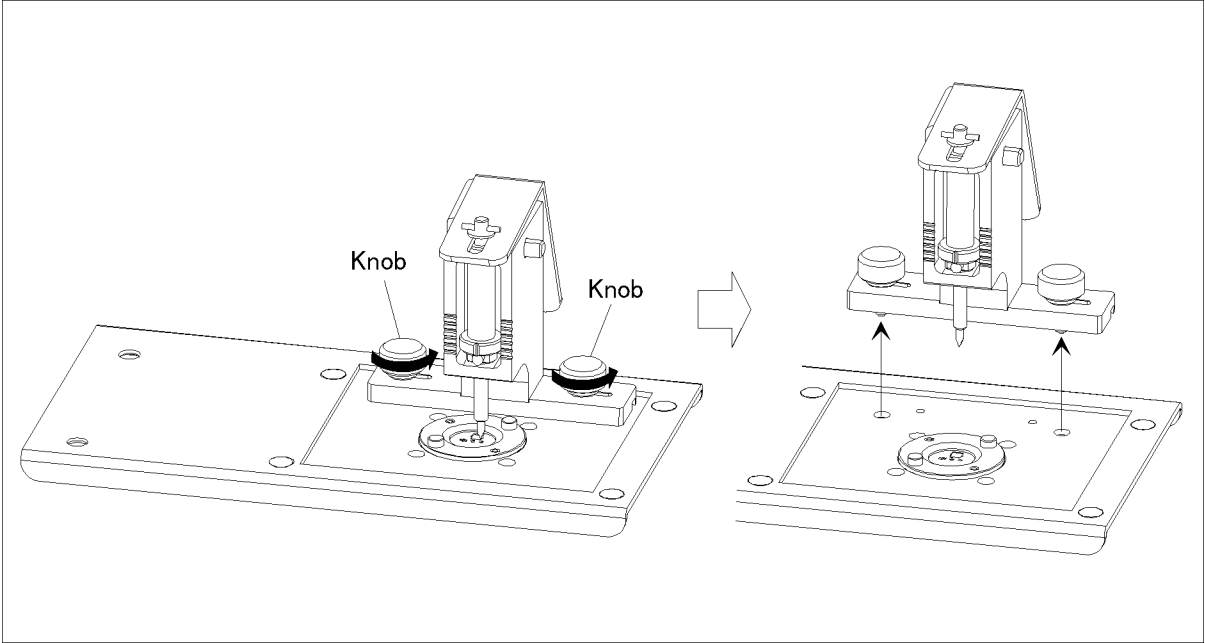

**Figure 1-5** Pressure Adjusting Nut

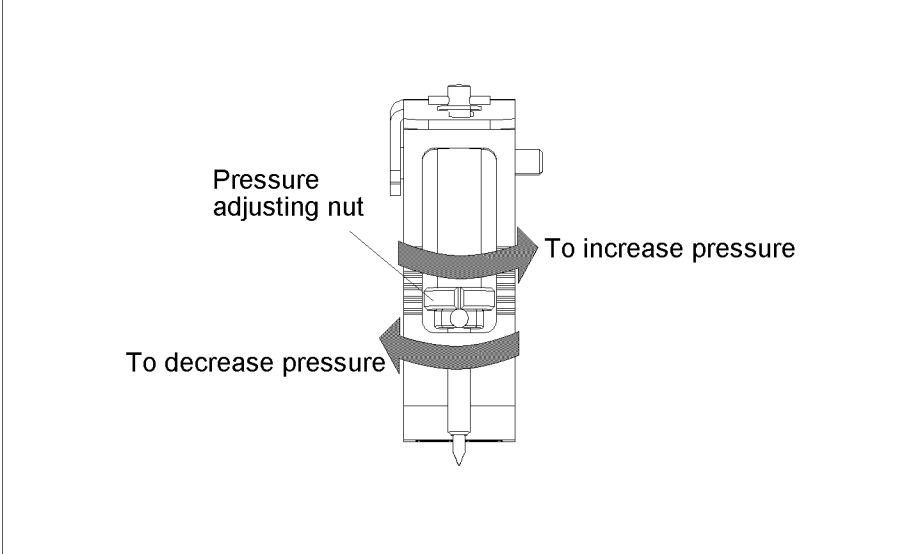

---

## Changing the Positions of the Guide Holder Fixing Screws

If the guide holder fixing screws hamper operation, the positions of these screws can be changed.

Figure 1-6

### Positions of the Guide Holder Fixing Screws

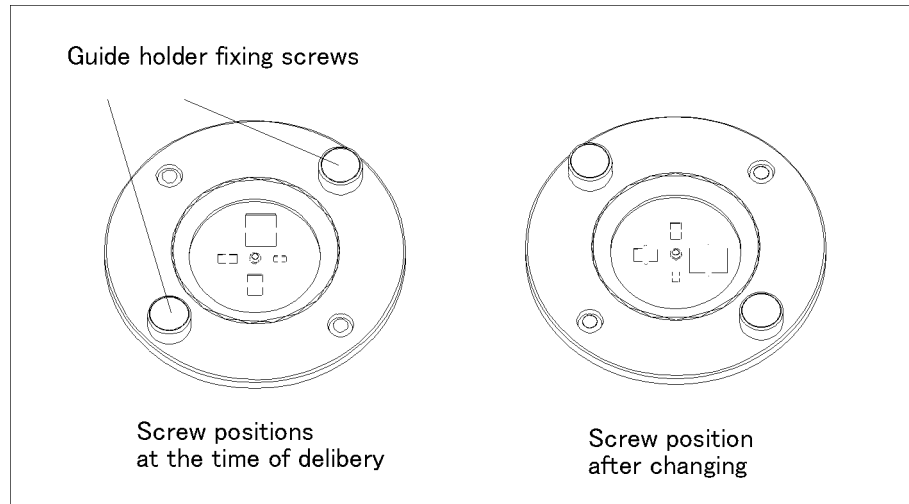

### Method for Changing the Positions of the Guide Holder Fixing Screws

Before changing the positions of the fixing screws, remove the pressure unit.

- Step 1.** Remove the four screws that fix the guide holder flange (Figure 1-7).
- Step 2.** Rotate the guide holder by 90 degrees together with the components fixed on the flange, and again set the guide holder in place (Figure 1-7).

Figure 1-7 Changing the Positions of the Guide Holder Fixing Screws

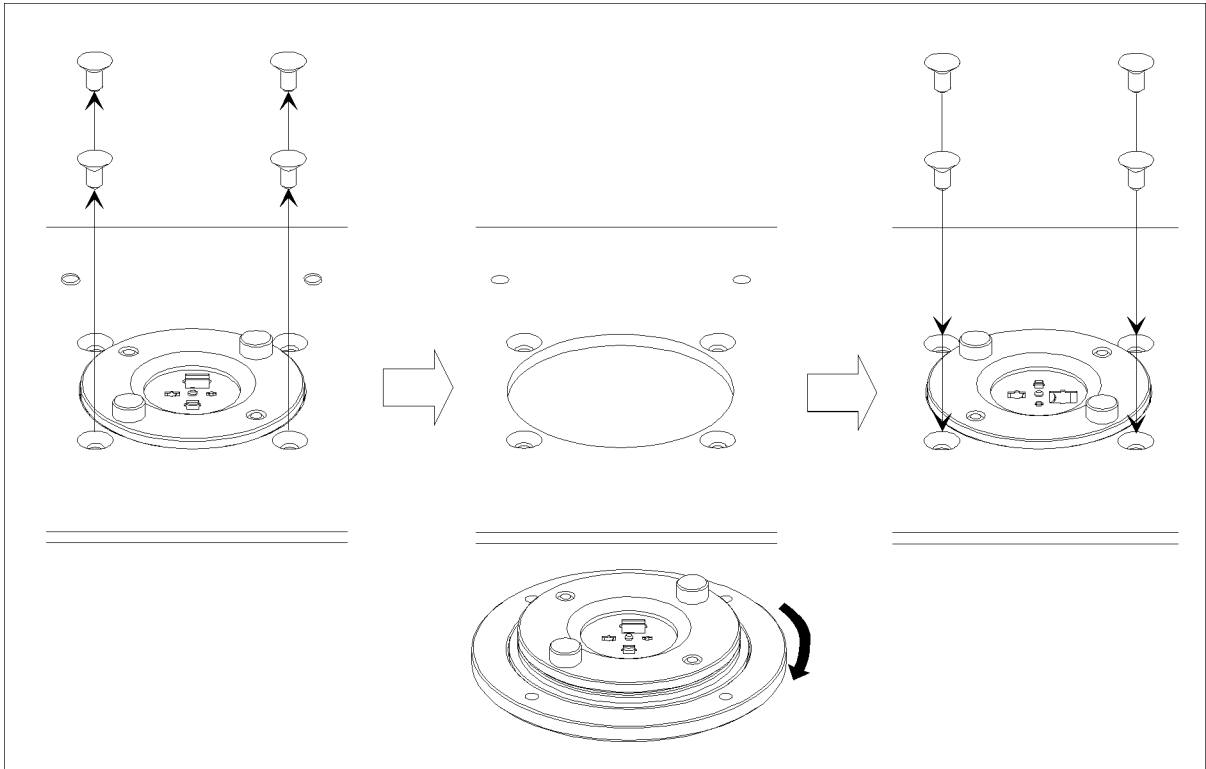

## Connecting the Test Fixture with a Measuring Instrument

Connecting the test fixture 16197A with a measuring instrument requires an adapter suited to the instrument.

The test fixture 16197A is suitable for use with a high-frequency LCR meter or an impedance analyzer. **Table 1-2** shows possible adapter combinations.

**Table 1-2 Adapter for a Measuring Instrument with a 7-mm Connector**

Measuring instrument	Adapter
4287A	Test head + Test fixture stand (supplied with the 4287A)
4291A/B	Test station + Test head (supplied with the 4291A/B)
4286A	Test head + Test fixture stand (supplied with the 4286A)
4395A *1	43961A impedance test adapter
4396B *1	43961A impedance test adapter
E4991A	Test head (supplied with the E4991A)

\*1. The measuring instrument requires the "Option 010 impedance measurement function".

The test fixture 16197A can also be connected with any measuring instrument with 4-terminal pair configuration if an appropriate adapter is used.

**Table 1-3 Adapter for a Measuring Instrument with 4-terminal Pair Configuration**

Measuring instrument	Adapter
4294A	42942A terminal adapter
4194A	41941A+ 16099A or 41941B+ 16099A
4192A, 4194A, 4263B, 4268A, 4278A, 4279A, 4284A, 4285A, 4288A, E4980A, E4981A	16085B terminal adapter

For the procedure for attaching an adapter, see the Operation Manual for the adapter.

### NOTE

Calibration on the 7-mm connector surface may be necessary depending on the type of measuring instrument. In such a case, perform calibration on the 7-mm connector surface before connecting the test fixture with the measuring instrument. For details, see the Operation Manual for the measuring instrument.

**Connecting the Test Fixture with a Measuring Instrument**

Below is the general procedure for attaching an adapter to the test fixture. (For details, see the Operation Manual for each adapter.)

- Step 1.** Rotate the 7-mm connector on the adapter counterclockwise as viewed from above to completely retract the connecting sleeve.
- Step 2.** Gently place the test fixture onto the adapter, aligning the mounting holes with the mounting posts on the adapter, and the 7-mm connector with that on the adapter.
- Step 3.** Rotate the 7-mm connector on the adapter counterclockwise as viewed from above to connect it with the connector on the bottom of the test fixture.

**NOTE**

Turn the 7-mm connector on the adapter using a 3/4-inch torque wrench with 12 lb-inch torque (Keysight part number: 8710-1766) to firmly connect the test fixture.

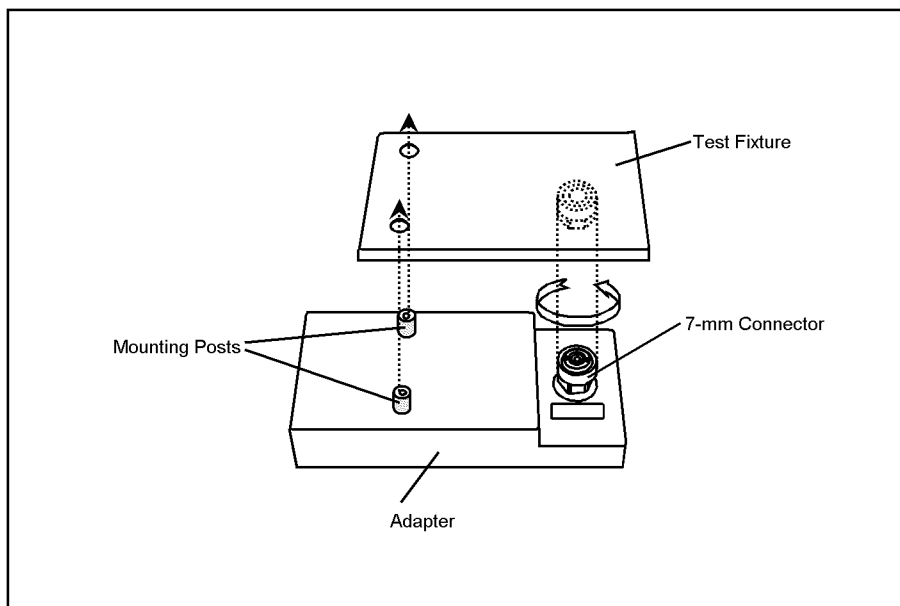
**Figure 1-8****Installing the Test Fixture**

16196abcj0101



---

**2**

## **Product Description**

## Product Description

The 16197A is a test fixture for use in measuring bottom-electrode chip components. It enables highly accurate and repeatable measurement of chip-type capacitors, inductors, and other similar components. The 16197A is compatible with measuring frequencies to 3 GHz, and can accommodate bottom-electrode chip components of sizes 3225 \*1(1210 \*2), 3216(1206 \*2), 2012 \*1(0805 \*2), 1608 \*1(0603 \*2), and 1005 \*1(0402 \*2). Measurement of chip components of other sizes is possible by preparing appropriate device guides.

Measurement of a bottom-electrode chip component of size 0603 \*1(0201 \*2) is also possible using the option.

**Figure 2-1**

### Product Appearance

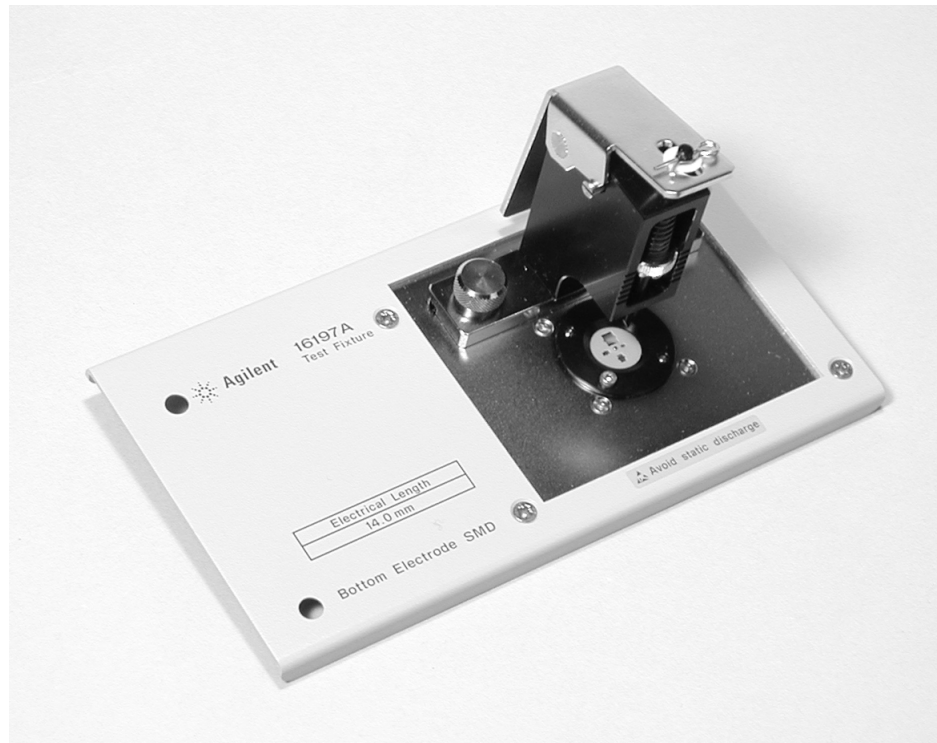

---

\*1.EIAJ size  
\*2.EIA size



### Mechanism for Connecting a DUT (Device Under Test)

The 16197A uses a device guide and an electrode plate for measuring to various sizes of bottom-electrode SMDs.

The electrode plate is placed onto the center electrode of the electrode unit, producing four different electrode spaces between the center electrode and electrode plate (Figure 2-2).

Figure 2-2

#### Structure of Electrode (1)

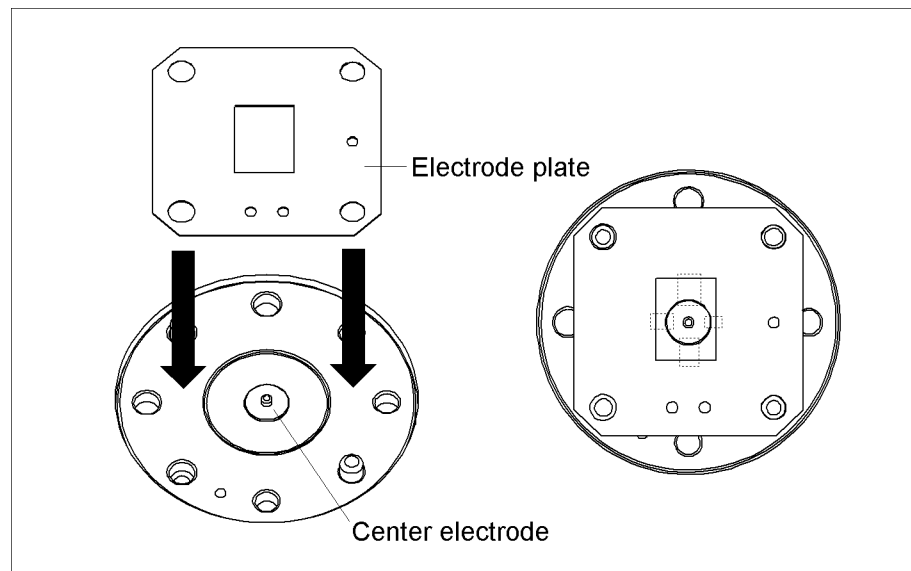

The device guide is placed on the electrode plate to enable each DUT to be positioned in a fixed location (Figure 2-3). Each DUT is set in a frame of the size suitable to the DUT for connecting to the electrode (Figure 2-4).

Figure 2-3

#### Structure of Electrode (2)

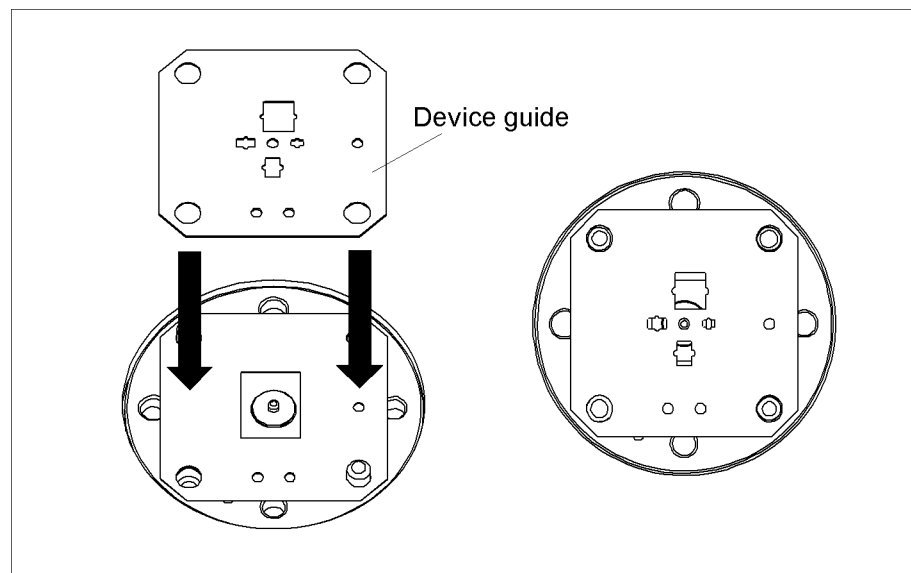
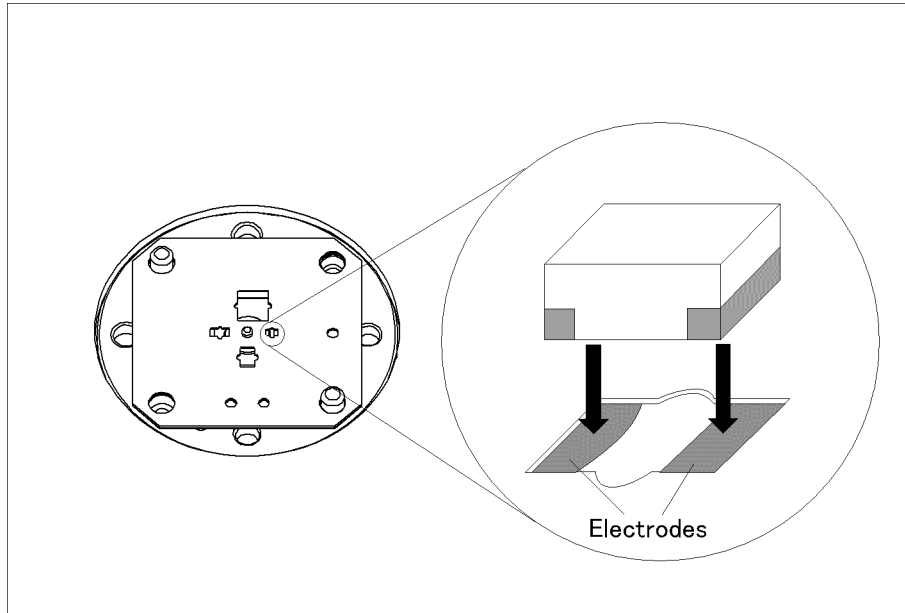
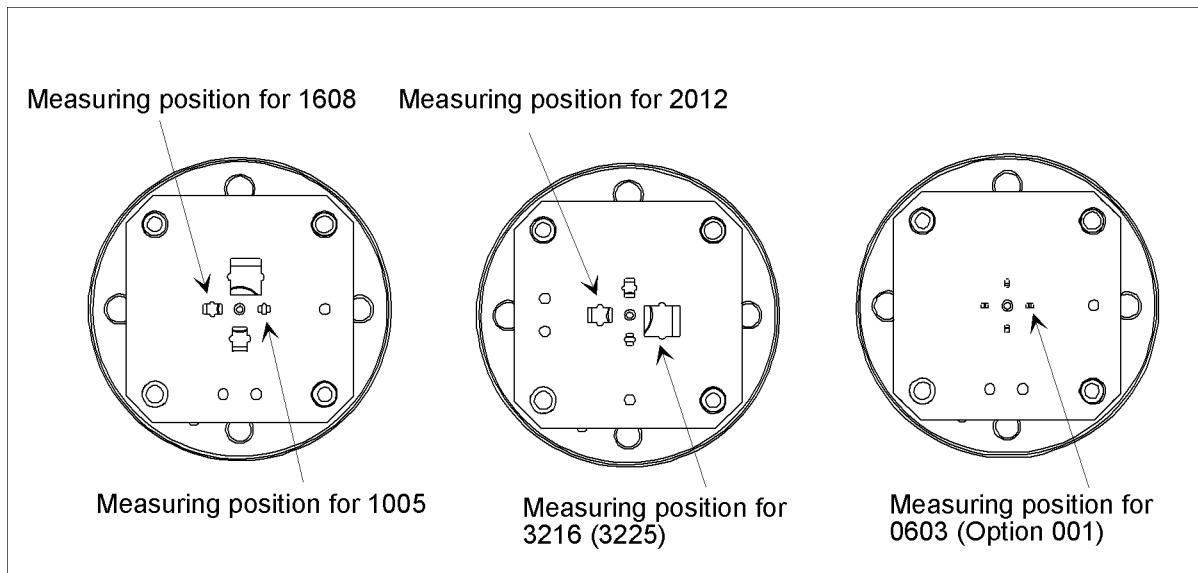

Figure 2-4 Connecting a DUT



The DUT is to be fixed under pressure from the pressure rod. Since the movable range of the pressure rod is limited, either one of the two lateral frames in the device guide can be used as the measuring position (Figure 2-5). Therefore, before connecting a DUT, it may be necessary to change the orientation of the electrode plate and device guide set in place so that the appropriate electrode and device guide frame arrive at the measuring position.

Figure 2-5 Measuring Position for Each Device Size



### Names & Functions of Parts

Figure 2-6 shows the part names for the 16197A.

**Figure 2-6** Names of Parts

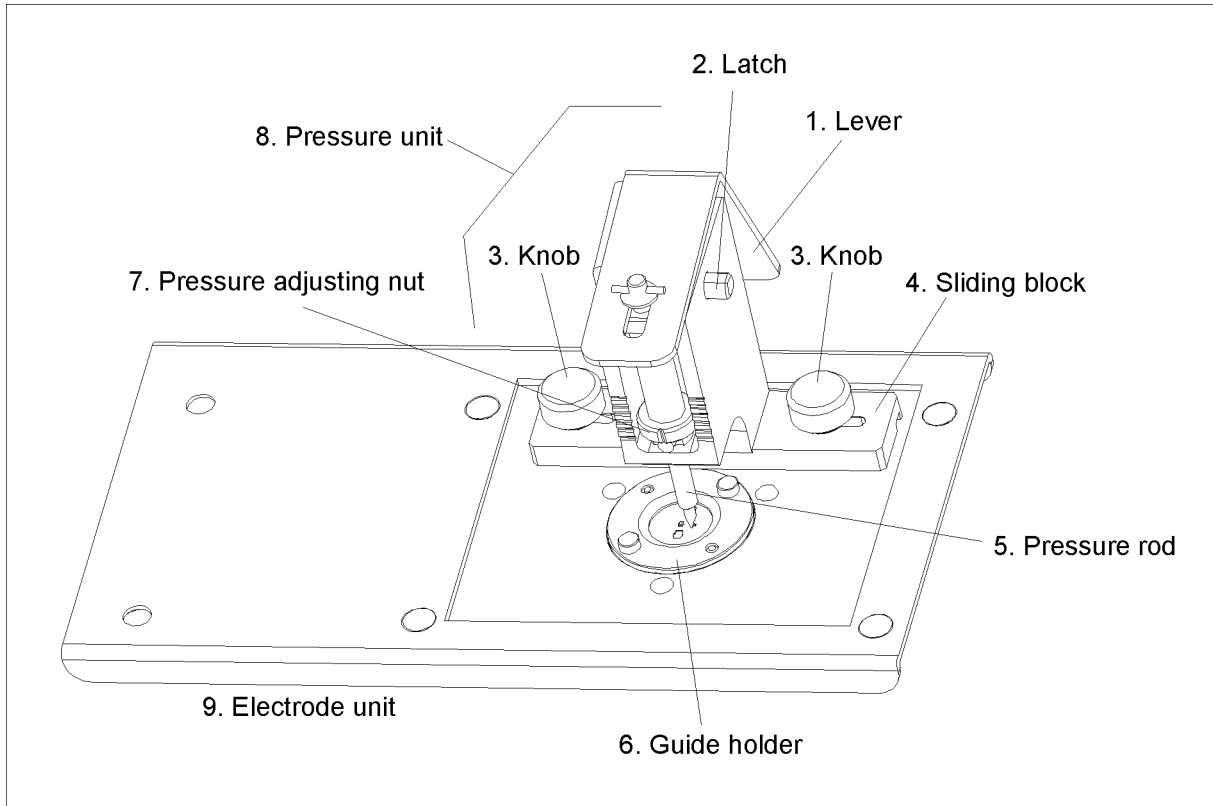

**Table 2-1** Names & Functions of Parts

No.	Name	Function
1	Lever	Used to raise or lower the pressure rod
2	Latch	Used to fix the lever to retain the pressure rod in its raised position
3	Knob	Used to fix the pressure unit
4	Sliding block	Used to laterally move the pressure unit
5	Pressure rod	Used to fix the DUT by downward pressure during measurement
6	Guide holder	Used to fix the electrode plate and device guide
7	Pressure adjusting nut	Used to adjust the DUT-retaining pressure of the pressure rod
8	Pressure unit	Apparatus to retain the DUT, etc.
9	Electrode unit	The electrode section to which the DUT, etc. are connected

Product Description  
**Product Description**

**Names & Functions of Accessories**

Figure 2-7 shows the names of standard accessories for the 16197A, and those of accessories available in Option 001.

Figure 2-7

**Accessories**

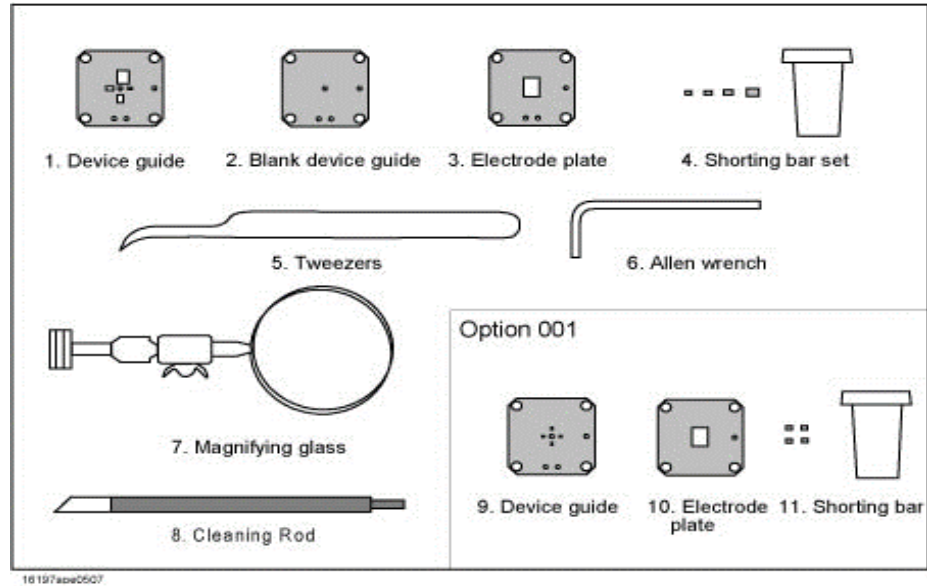

Table 2-2

**Names & Functions of Accessories**

No.	Name	Function
1	Device guide* <sup>1</sup>	Used to position the DUT, etc. when connecting it to the electrode
2	Blank device guide	Used to prepare a device guide frame suited to a DUT of a size not fitting any frame in the attached device guide
3	Electrode plate* <sup>1</sup>	Used to create various electrode spaces
4	Shorting bar set	Shorting bars in EIA/EIAJ sizes, and a case for storing them. These bars are used during of SHORT compensation.
5	Tweezers	Used to handle shorting bars, the DUT, etc.
6	Allen wrench	Used to tighten/loosen hexagonal nuts
7	Magnifying glass	Used to magnify the view of a connector, electrode, etc.
8	Cleaning rod	Used to clean the electrodes. Refer to “Cleaning Method,” on page 54 in Chapter 4.
Option 001		

**Table 2-2**

**Names & Functions of Accessories**

<b>No.</b>	<b>Name</b>	<b>Function</b>
9	Device guide	Device guide for 0603 devices
10	Electrode plate	Electrode plate for 0603 devices
11	Shorting bar	Shorting bars for 0603 devices, and a case for storing them. These bars are used during SHORT compensation.

\*1. Delivered attached to the electrode unit

Product Description  
**Product Description**

---

## 3 **Operation**

This chapter describes the procedures for measurement preparation, fixture compensation, connection of a DUT, and measurement with the 16197A.

## **Measurement Flow**

To measure a DUT by taking measurements with the 16197A, follow the procedure below.

1. Setting the measuring conditions  
Set the measuring conditions for the measuring instrument to be used.
2. Performing calibration  
Calibrate the measuring instrument and adapters, if necessary.
3. Setting the electrical length  
Set the electrical length for the measuring instrument, if necessary.
4. Changing the orientation of the device guide and electrode plate  
Select a device guide frame that fits the configuration of the DUT, and change the orientation of the device guide and electrode plate set on the center electrode, if necessary.
5. Performing fixture compensation  
Measure the SHORT compensation and OPEN compensation data.
6. Connecting and measuring the DUT  
Connect the DUT to the fixture and perform the measurement.

---

### **WARNING**

The **16197A** has the capability for -55°C to +85°C temperature measurement in environmental testing. Use gloves to prevent burns when handling heated parts.



Figure 3-1 Measurement Flow

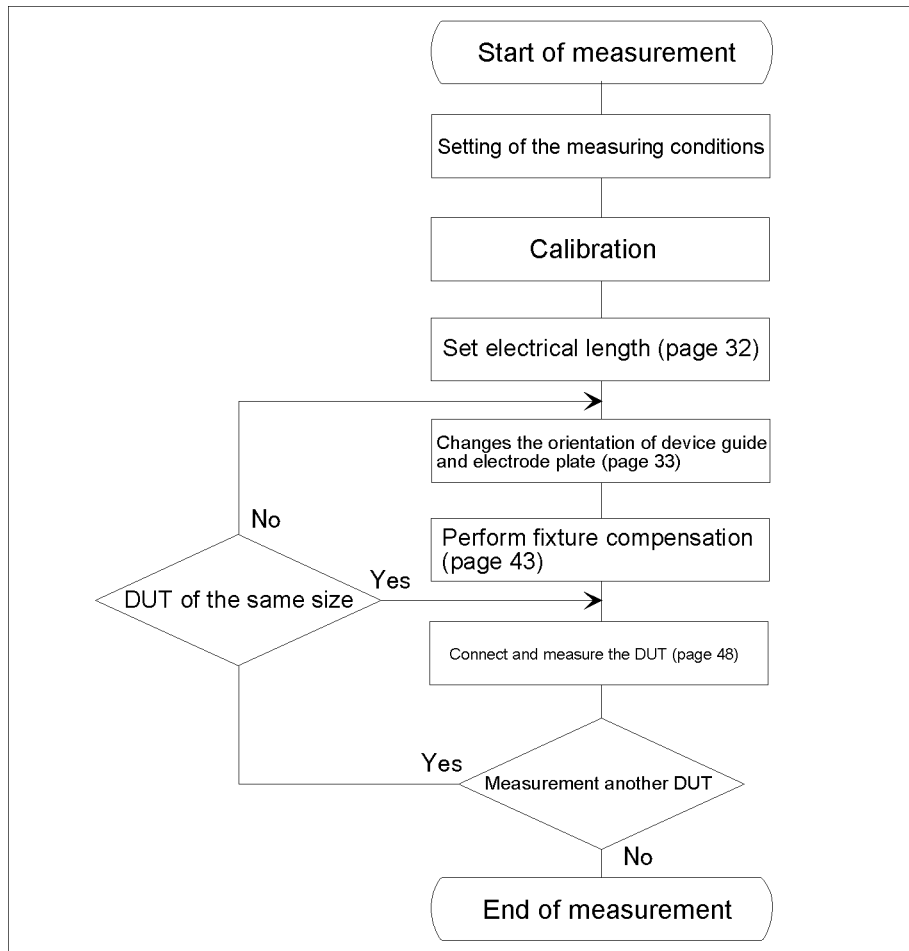

The calibration methods, electrical length setting, and fixture compensation all differ with the measuring instrument being used. See the operation manual for the measuring instrument to be used.

**NOTE**

To ensure accurate measurement with the 16197A, it is necessary to perform a deterioration check of the shorting bars. For details, see [“Deterioration Check” on page 56](#).

## **Setting the Electrical Length**

Set the electrical length for the measuring instrument, if necessary. For the method of setting the electrical length, see the operation manual for the measuring instrument. The electrical length for the 16197A is as follows:

<b>Model</b>	<b>Electrical length [mm]</b>
16197A	14.00 mm

## Changing the Orientation of the Device Guide and Electrode Plate

Select a device guide frame suited to the DUT size, and mount the appropriate device guide and electrode plate in the proper orientation so that a suitable frame is located at the measuring position.

### Selecting the device guide frame

Select a device guide frame suited to the DUT size, with reference to [Table 3-1](#).

**Table 3-1 Device Guide Frames and Applicable Device Sizes and Specifications**

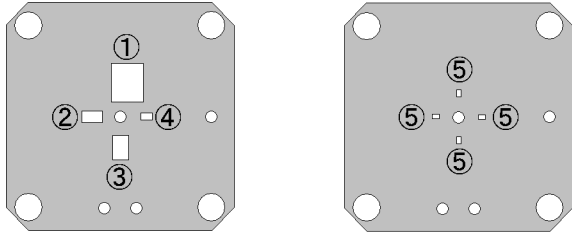
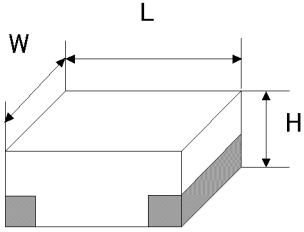
Frame position	Device size		Applicable chip size (mm)		
	EIAJ size	EIA size	Length (L)	Width (W)	Height (H)
1	3225	1210	$3.2 \pm 0.15$	$2.5 \pm 0.15$	0.4
	3216	1206	$3.2 \pm 0.15$	$1.6 \pm 0.15$	0.4
3	2012	0805	$2.0 \pm 0.15$	$1.25 \pm 0.15$	0.4
2	1608	0603	$1.6 \pm 0.15$	$0.8 \pm 0.15$	0.4
4	1005	0402	$1.0 \pm 0.15$	$0.5 \pm 0.15$	0.4
5	0603	0201	$0.6 \pm 0.03$	$0.3 \pm 0.03$	0.25
					

**NOTE**

An excessively large gap between the DUT and device guide frame will result in contact failure between the DUT and electrode, or poor measurement accuracy or repeatability. Be sure to select a device guide frame that fits the DUT configuration.

If the DUT size does not fit any frame in the attached device guide, prepare a suitable frame using the supplied blank device guide. For details, see [“Working with the Device Guide”](#).

**Figure 3-2**

**Electrode Spacing**

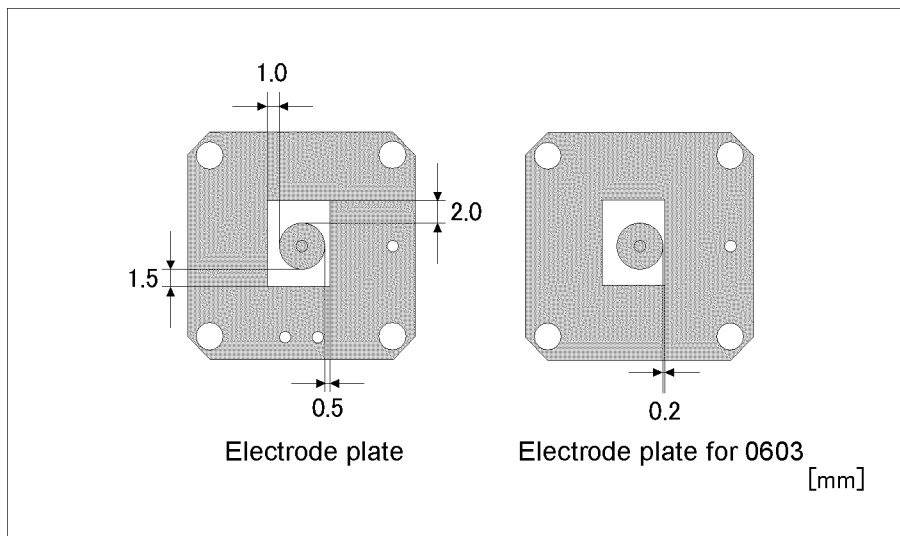

**Figure 3-3**

**Dimensions of the Device Guide Frame**

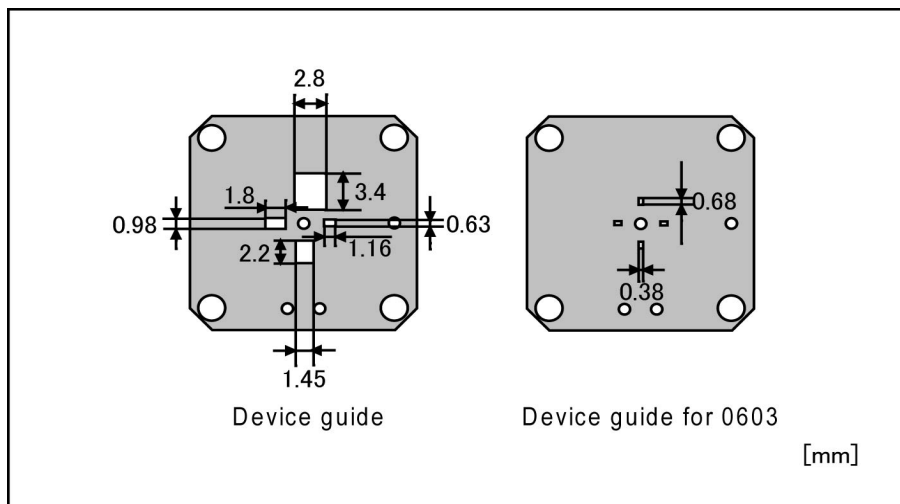

16197aoe030

**CAUTION**

Be sure to superpose the device guide onto the electrode plate in the proper orientation and with the correct side facing up. Otherwise, adequate electrode spacing cannot be created. As shown in Figure 3-3, when viewed from above, on the correct face of the device guide there are two marks at positions 90 degrees apart clockwise from a single position. Superpose the device guide onto the electrode plate so that all these marks are aligned with the corresponding marks on the electrode plate. For a 0603 device, correct electrode spacing can be created regardless of whether the mark on the device guide is aligned with

**Changing the Orientation of the Device Guide and Electrode Plate**

the corresponding mark on the electrode plate

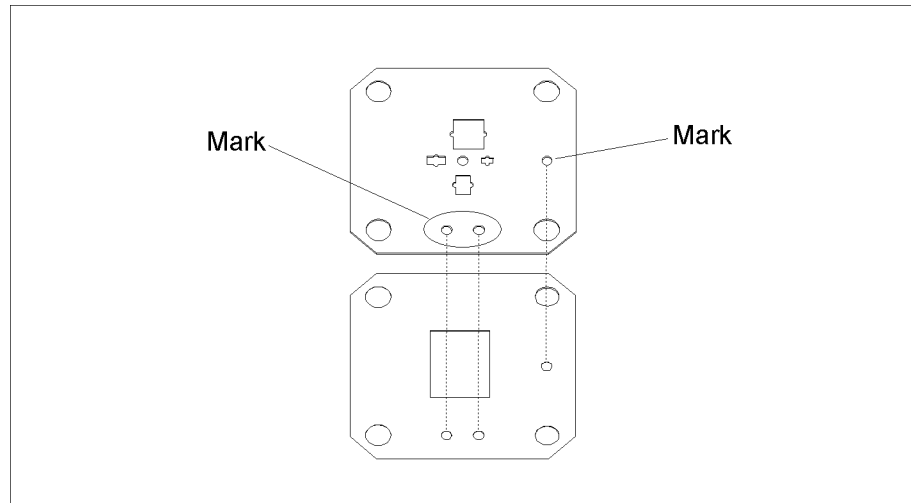

---

**Changing the Orientation of or Replacing the Device Guide and Electrode Plate**

Change the orientation of the device guide and electrode plate so that the selected device guide frame is located at the measuring position. For a 0603 device, replace the attached device guide and electrode plate with ones supplied in Option 001.

- Step 1.** Loosen the knobs on the sliding block, and remove the pressure unit from the electrode unit, referring to [Figure 1-4 on page 15](#).
- Step 2.** Unscrew the screws that fix the guide holder. Then remove the guide holder, device guide, and electrode plate ([Figure 3-4](#)).

Figure 3-4

## Removing the Device Guide and Electrode Plate

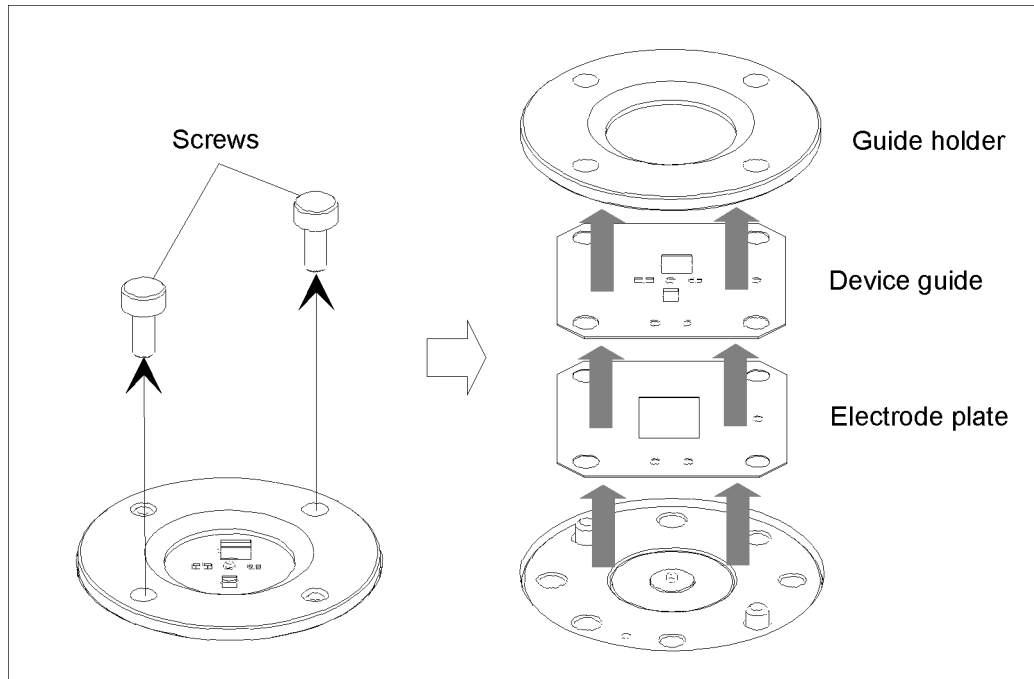
**NOTE**

If it is difficult to take out the electrode plate, turn the electrode unit upside down to remove the plate. Do not use force to take out the electrode plate, otherwise it may be deformed.

- Step 3.** Mount the device guide and electrode plate so that the selected device guide frame is located at the measuring position. Ensure that the marks on the device guide are aligned with those on the electrode plate (Figure 3-5). For a 0603 DUT, replace the attached device guide and electrode plate with ones supplied in Option 001 (Figure 3-6).

Changing the Orientation of the Device Guide and Electrode Plate

**Figure 3-5** Mounting the Device Guide and Electrode Plate

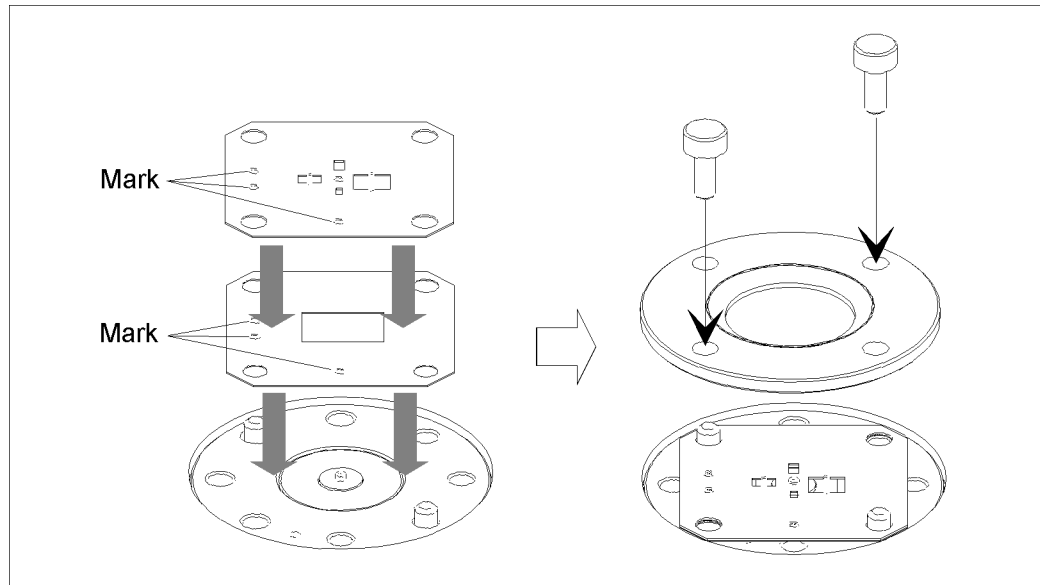

**Figure 3-6** Mounting the Device Guide and Electrode Plate for 0603

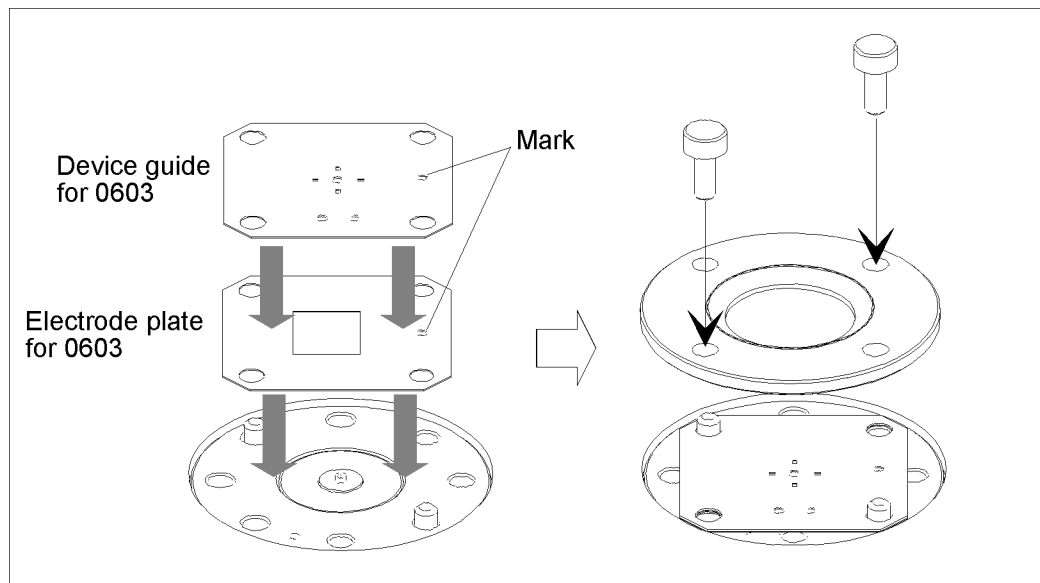

**CAUTION** Do not touch or damage the center electrode or electrode plate, otherwise measurement accuracy and repeatability may be impaired.

**NOTE** Be sure to mount the device guide and electrode plate with the correct sides facing up.

**Step 4.** Install the guide holder, and tighten the screws to secure it.

**Step 5.** Mount the pressure unit onto the electrode unit according to [Figure 1-2 on page 13](#).

**Step 6.** Connect the test fixture with the measuring instrument.

Operation

### **Changing the Orientation of the Device Guide and Electrode Plate**

Connect the test fixture with the measuring instrument according to “[Connecting the Test Fixture with a Measuring Instrument](#)” on page 18 in Chapter 1.



## Working with the Device Guide

To measure a DUT whose size does not fit any frame in the attached device guide, it is necessary to prepare a suitable device guide frame. Prepare a frame with reference to the dimensions of the blank device guide shown in [Figure 3-7](#) and the electrode positioning shown in [Figure 3-8](#).

### Reference Data for Preparing a Device Guide Frame

**Figure 3-7** Dimensional Drawing of a Blank Device Guide

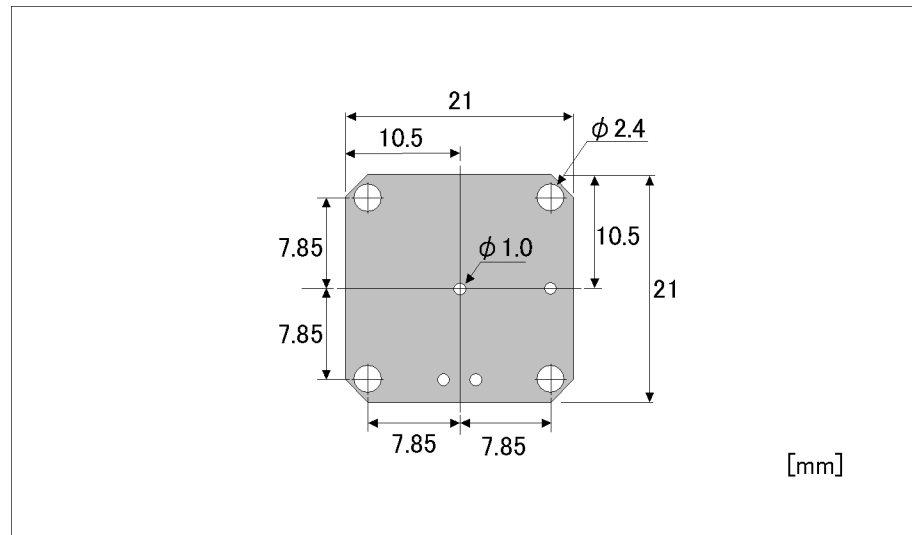

**Figure 3-8** Electrode Positioning

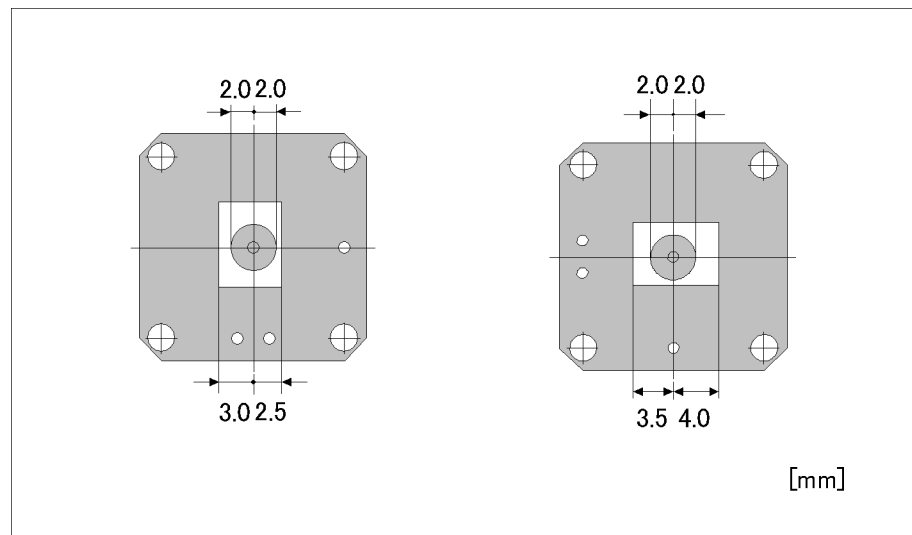

A guide holder is placed onto the device guide. [Figure 3-9-A](#) shows the inside diameter of the guide holder. [Figure 3-9-B](#) shows the movable range of the pressure rod.

**Figure 3-9**

**Inside Diameter of Guide Holder & Movable Range of Pressure Rod**

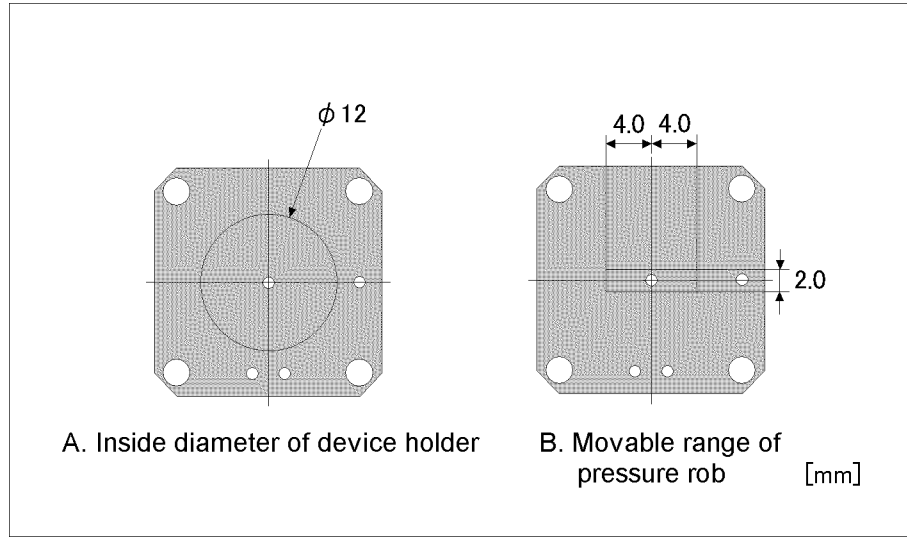

Determine the position of the frame to be prepared, keeping in mind the following requirements:

- The electrode of the DUT must maintain equal contact with both the center electrode and electrode plate.
- The electrode of the DUT must have a large contact area, and the electrode space between the center electrode and electrode plate must be as large as possible.
- The pressure rod must be able to press the center of the DUT to stabilize the DUT during measurement.

**Example of Preparing the Device Guide**

**Preparing the Device Guide for a 2520 SMD**

The figure below shows an example of preparation for a device guide for a 2520 SMD. For a 2520 SMD, the measuring position for a 2012 device is used (electrode space: 1.5 mm).

**Figure 3-10 Example of Preparation of Device Guide for 2520 SMD**

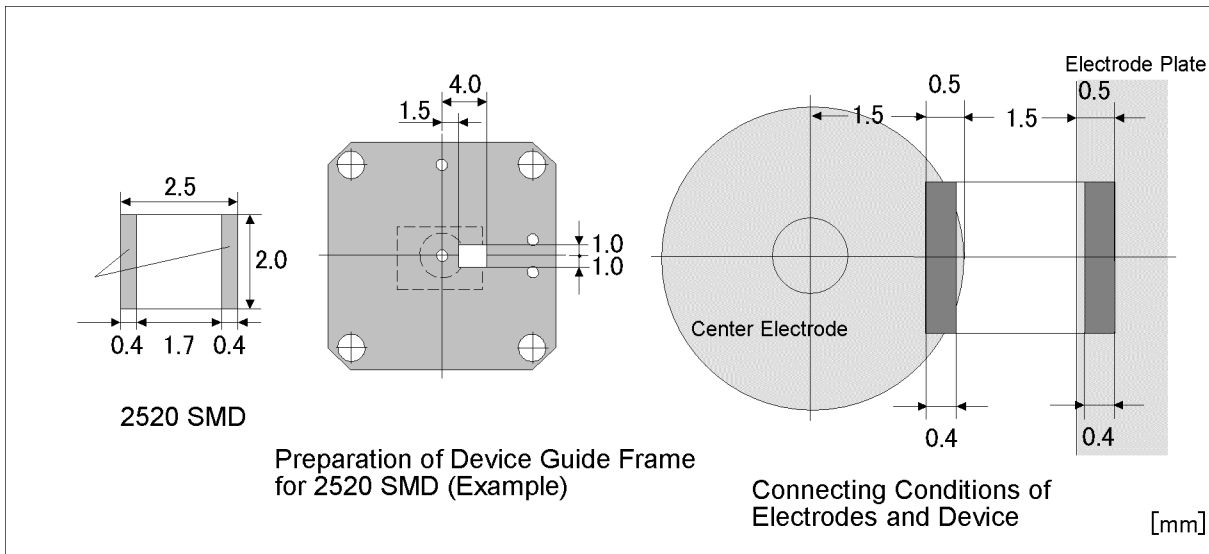

Prepare the frame at the position shown in [Figure 3-10](#). This position is within the movable range of the pressure rod (4 mm on each lateral side from the center). In a frame at this position, the electrodes on both lateral sides of the DUT can be placed in equal contact by 0.4-mm width with the center electrode and the electrode plate.

**Example of Preparing the Device Guide for an SOT 23 Device (Case Style 287)**

The figure below shows an example of preparing a device guide for an SOT 23 device. For an SOT 23 device, the measuring position for a 1608 device is used (electrode space: 1.0 mm).

**Figure 3-11 Example of Preparing the Device Guide for an SOT 23 Device (Case Style 287)**

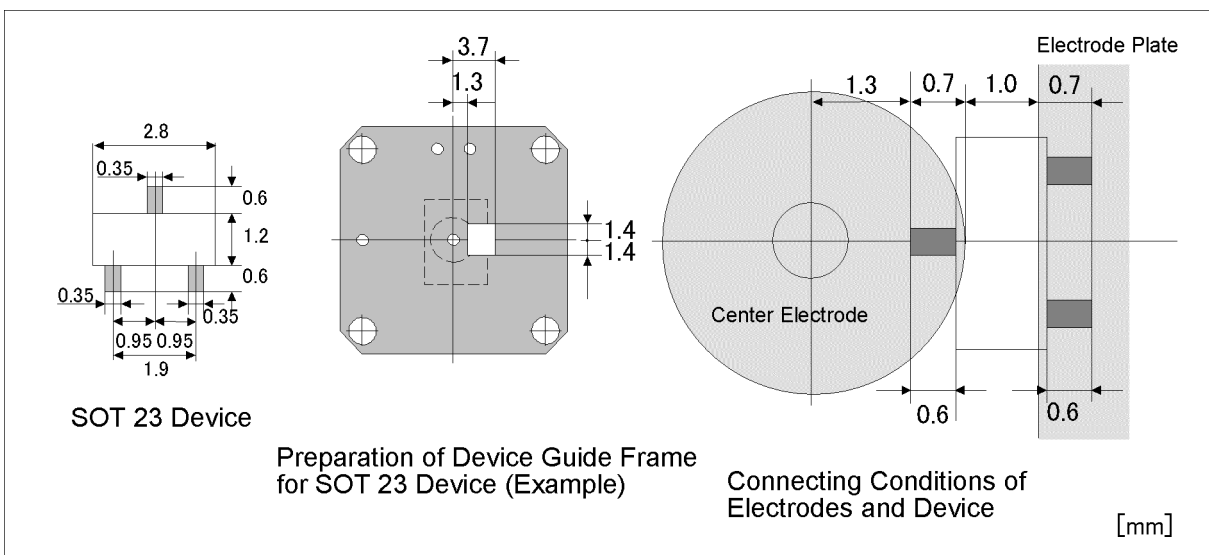

Prepare a frame at the position shown in [Figure 3-11](#). In a frame at this position, the electrodes on both lateral sides of the DUT can be placed in equal contact by 0.6-mm width with the center electrode and the electrode plate.

### Example of Preparing a Simple Device Guide

In order to prepare the device guide more easily, there is a method that involves precisely cutting only the 2 sides that position the device over the electrodes. Do not cut the corner hole which mounts the device guide.

---

**CAUTION**

The measurement accuracy when using this method is not guaranteed.

### Preparing the Simple Device Guide for a 2520 SMD

The position which places the 2520 SMD is same as [Figure 3-10](#). Cut the 2 sides precisely which fixes the device position as shown in [Figure 3-12](#).

**Figure 3-12**

### Example of Preparing the Simple Device Guide for a 2520 SMD

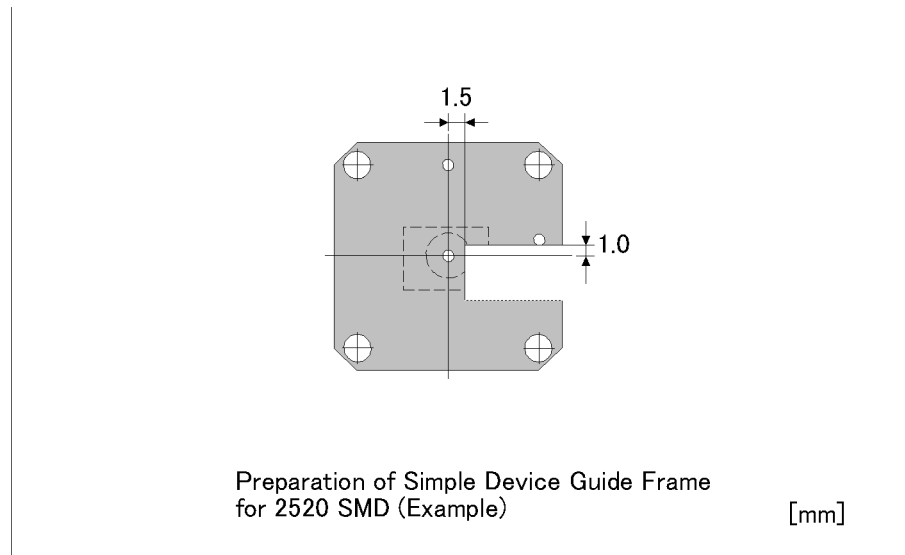

## Performing Fixture Compensation

To ensure accurate measurement, it is necessary to perform fixture compensation before measurement. For the 16197A, measure the SHORT compensation and OPEN compensation data. If the DUT size or the measuring position is changed, perform fixture compensation again.

### NOTE

If a temperature change greater than  $\pm 5\text{C}$  occurs after fixture compensation, perform the fixture compensation from the beginning.

## Measuring the SHORT Compensation Data

With the fixture SHORT state using a supplied shorting bar, measure the SHORT compensation data.

- Step 1.** Rotate the pressure adjusting nut to adjust the pressure on the pressure rod to the same value as used for measurement.
- Step 2.** Loosen the knobs on the sliding block, and adjust the position of the pressure unit so that the end of the pressure rod is located at the center of the device guide frame where the shorting bar will be placed (Figure 3-13).

**Figure 3-13** Adjusting the Pressure Unit Position

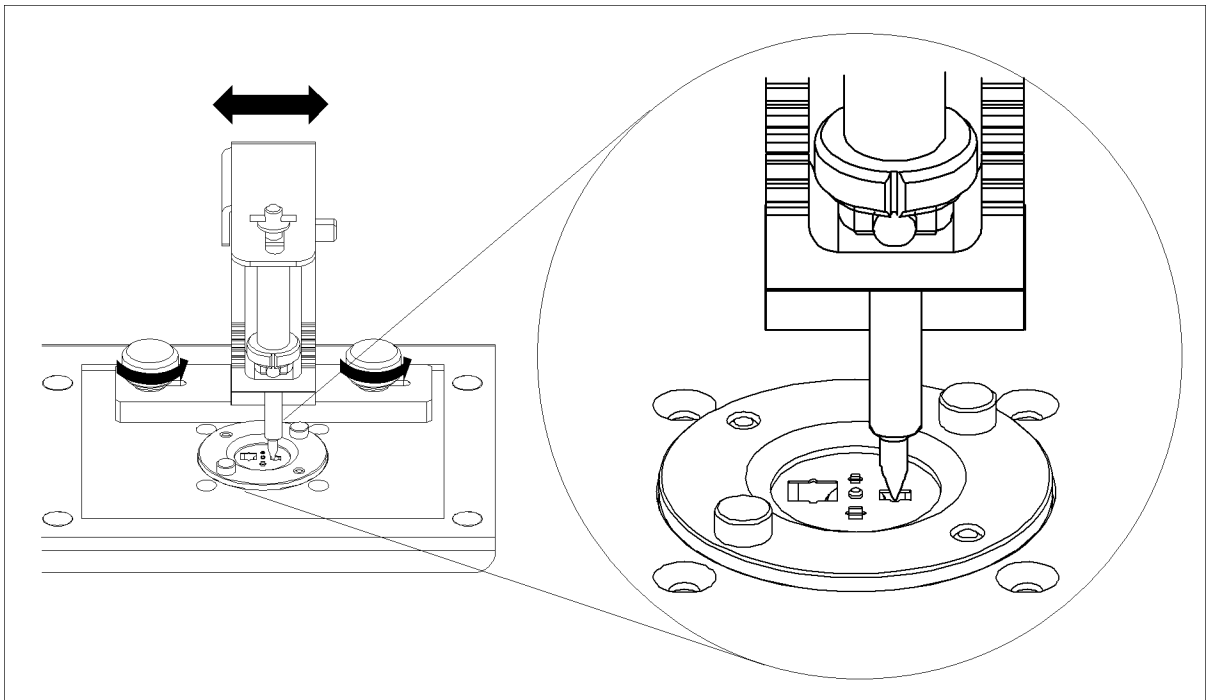

- Step 3.** Press the lever to the limit (Figure 3-14,1). With the lever pressed, push in the latch (Figure 3-14,2), and then release the lever (Figure 3-14,3). The pressure rod is then fixed at its raised position.

Operation  
Performing Fixture Compensation

Figure 3-14 Raising the Pressure Rod

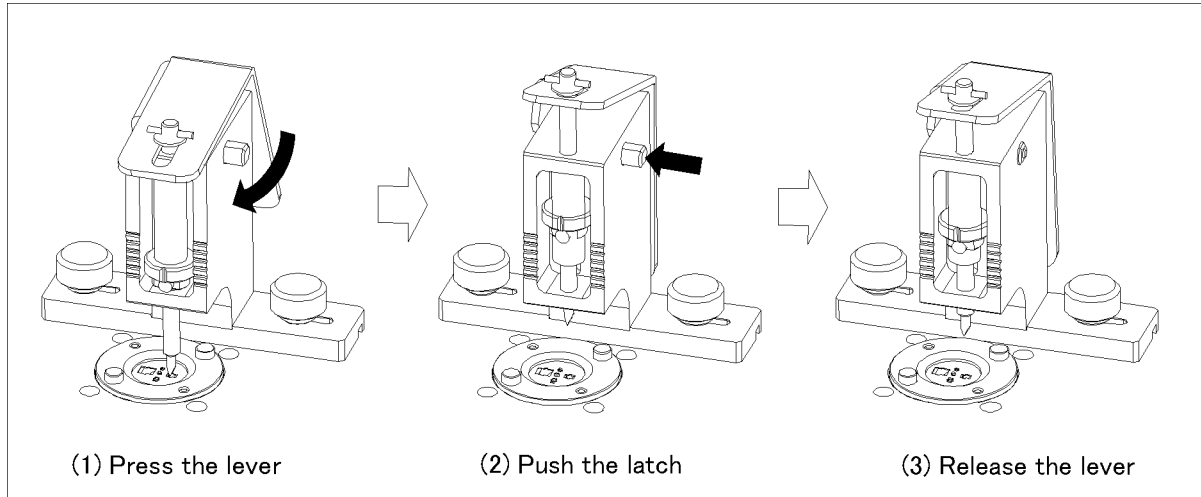

**Step 4.** Using tweezers, place an appropriate shorting bar on the electrode along the device guide frame.

---

**CAUTION** Each shorting bar is made exclusively for a particular device size. Do not use a shorting bar of the wrong size.

---

Figure 3-15 Connecting the Shorting Bar

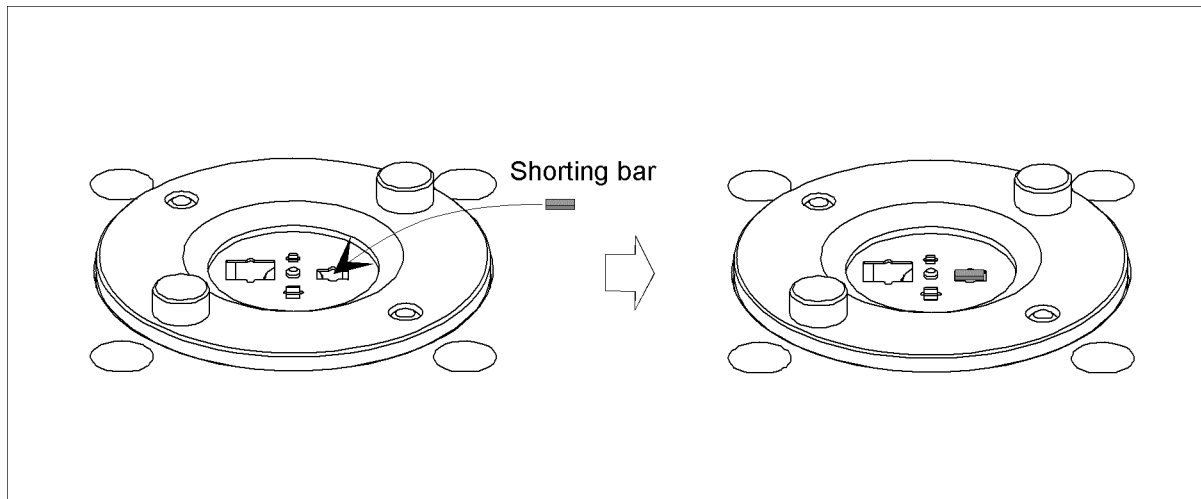

---

**CAUTION** Handle each shorting bar with tweezers, taking care not to soil it. A soiled shorting bar may impair measurement accuracy and repeatability.

---

---

**NOTE** Take care so that the correct face of the shorting bar is placed in contact with the electrode.

---

---

**NOTE** Shorting bars can wear out. Therefore, each time before using a shorting bar, measure and compare its resistance with that of a new shorting bar. For details, see **“Operation Check”**

---

on page 76.

**Step 5.** Press the lever; the latch is disengaged (Figure 3-16,1). Slowly release the lever to lower the pressure rod (Figure 3-16,2).

**Figure 3-16**      **Setting the Fixture for SHORT State Using a Shorting Bar**

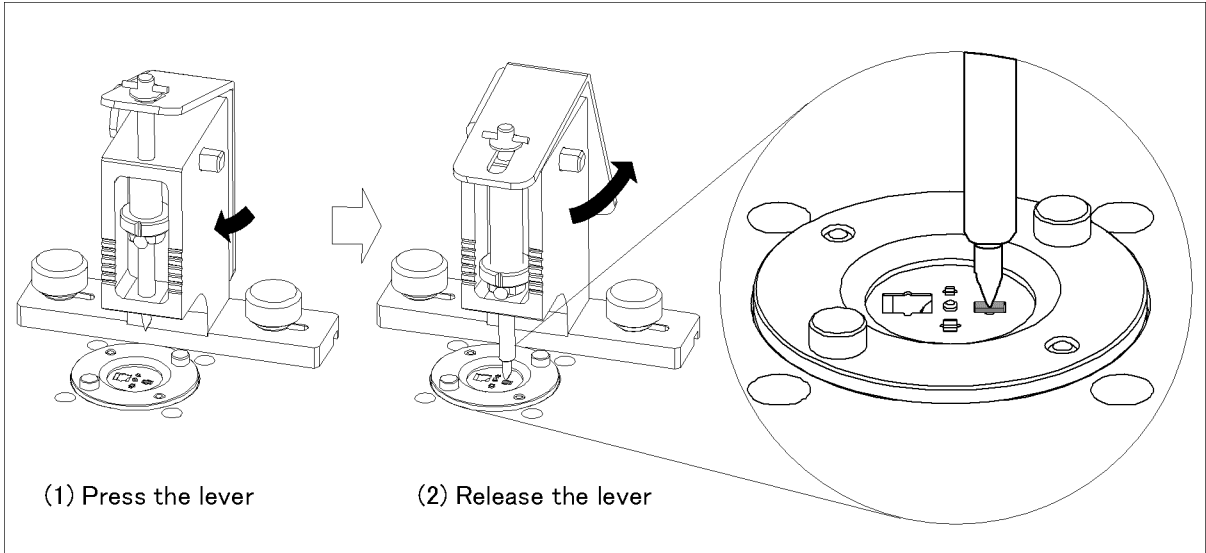

**NOTE**      Adjust the position of the pressure unit in advance so that a shorting bar can be pressed at its center by the end of the pressure rod.

**Step 6.** Measure the SHORT compensation data according to the operation manual for the measuring instrument to be used.

**NOTE**      When measurement is not being done, lower the pressure rod so it rests on an unoccupied area of the device guide.

Operation  
**Performing Fixture Compensation**

**Figure 3-17**

**Standby Position of the Pressure Rod**

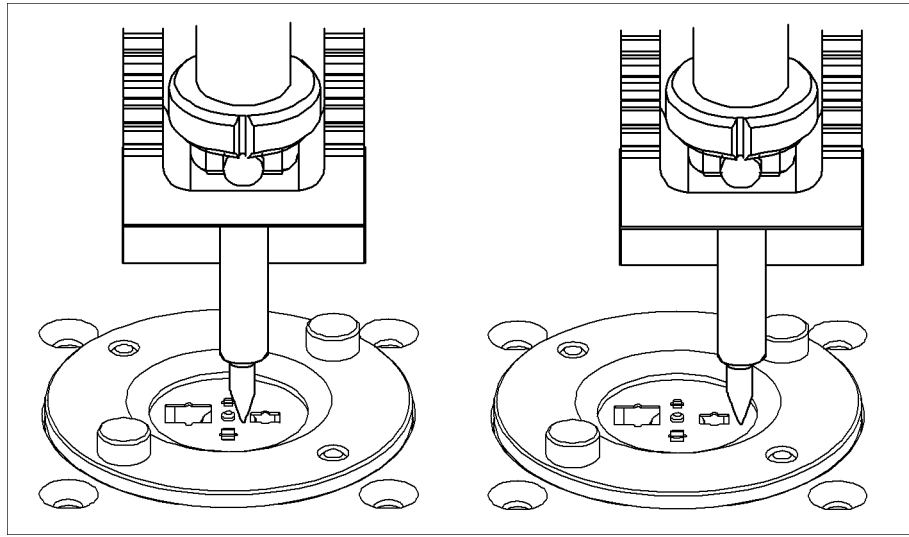

---

---

**NOTE**

Confirm that the end of the pressure rod is not deformed. Replace the rod if deformed. For the replacement part, see [“Replaceable Parts” on page 70](#).



### Measuring the OPEN Compensation Data

With the fixture in an OPEN state, measure the OPEN compensation data.

- Step 7.** Press the lever to raise the pressure rod, and remove the shorting bar used to measure the SHORT compensation data (Figure 3-18,1).
- Step 8.** Press the lever to raise the pressure rod (Figure 3-18,2), and push the latch to secure the pressure rod in its raised position (Figure 3-18,3).

**Figure 3-18**      **Setting the Fixture for OPEN State**

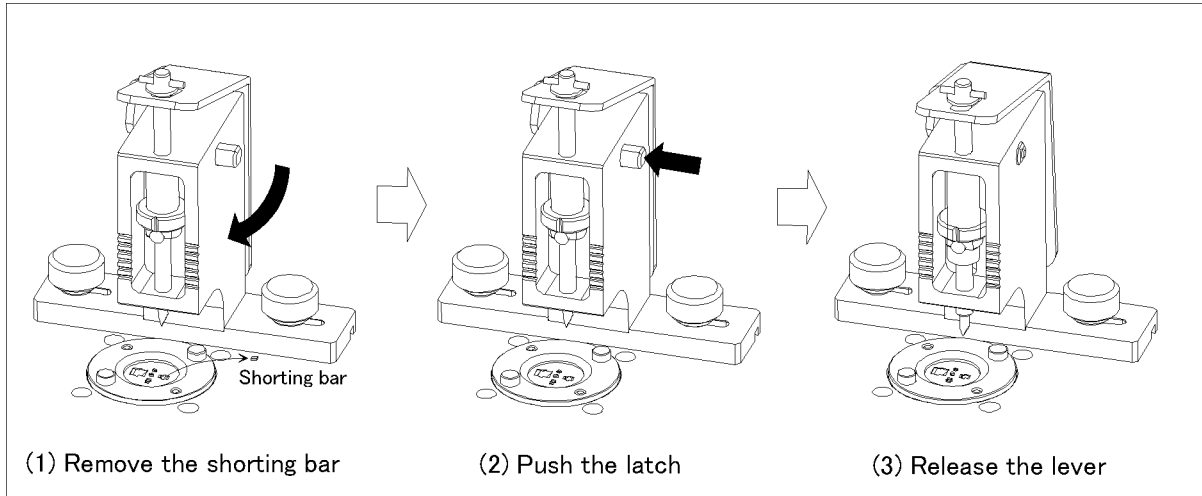

- Step 9.** Measure OPEN compensation data according to the operation manual for the measuring instrument to be used.

---

## Connecting and Measuring the DUT

Connect the DUT with the electrode, and carry out the measurement.

- Step 1.** Place the DUT on the electrode in an appropriate device guide frame (Figure 3-19,1).
- Step 2.** Press the lever to disengage the latch (Figure 3-19,2), and slowly release the lever to lower the pressure rod (Figure 3-19,3).

**Figure 3-19**      **Connecting the DUT**

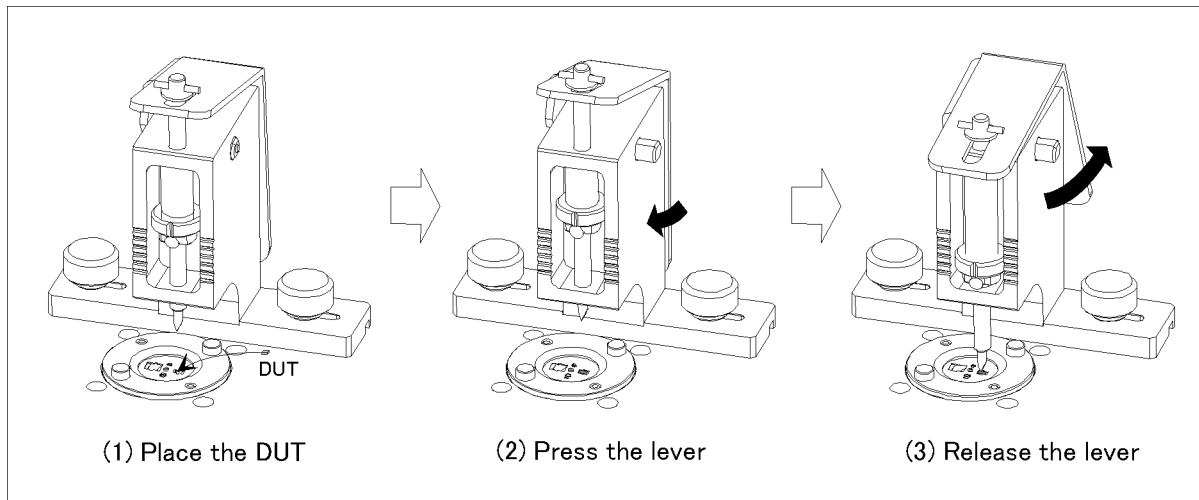

- Step 3.** Perform the measurement according to the operation manual for the measuring instrument to be used.

---

### CAUTION

The DUT may become hot during measurement. If the temperature of the DUT rises, the end of the pressure rod may be deformed. If this occurs, decrease the pressure on the pressure rod to prevent deformation of the end of the rod.

---

### NOTE

To ensure accurate and repeatable measurements, place the DUT alongside a fixed edge of each device guide frame. Testing a 3216 DUT, for instance, uses the 3216/3225 frame. Since this frame is dimensioned to fit with a 3225 device, some clearance remains in the frame if it is used for a 3216 DUT. Therefore, it is necessary to place the DUT alongside a fixed edge of the frame.

Figure 3-20 DUT Position in the Device Guide Frame

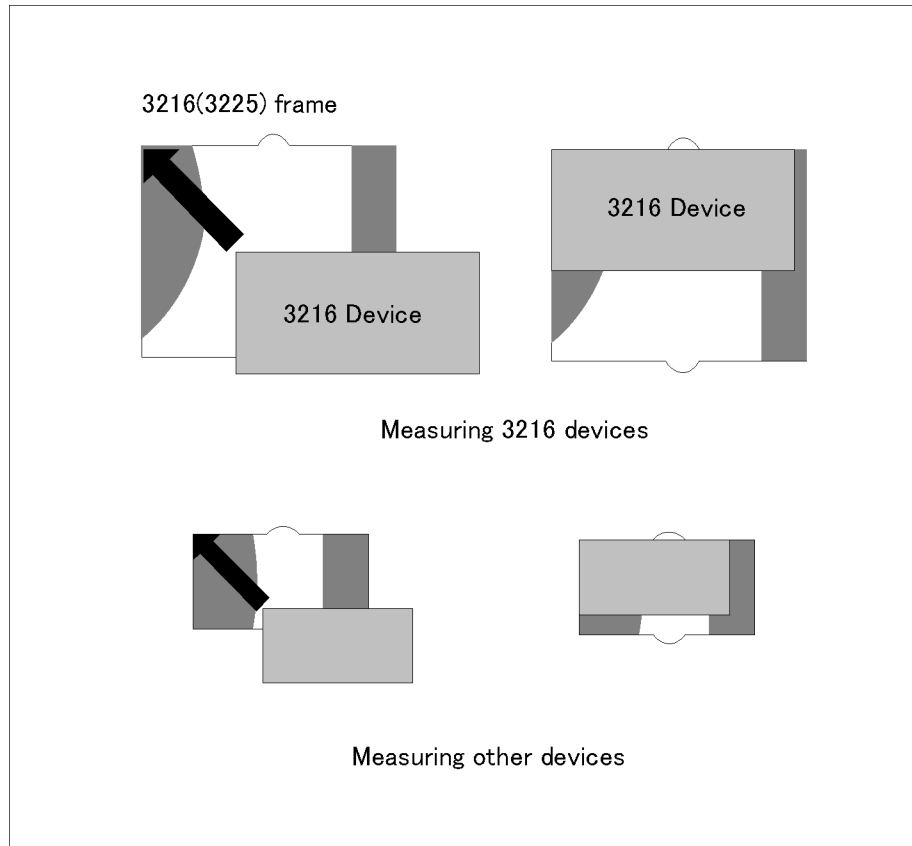

Operation  
**Connecting and Measuring the DUT**

---

# 4

## User Maintenance

This chapter describes the operations to perform before starting measurement, and the procedures necessary to ensure accurate measurements.

## Description

### Necessity of User Maintenance

Through repeated use, the fixture's measuring performance will gradually deteriorate over time due to smearing on the contact faces from solder buildup, and to mechanical wear and deformation of the contact faces themselves. To continually achieve optimal measurement results, it is important to keep the contact faces in good condition and take appropriate action before such wear or deformation occurs. Therefore, the fixture should be properly cared for by implementing each of the maintenance items shown in [Table 4-1](#).

**Table 4-1 Maintenance Items**

Name	Frequency of implementation	Contents	Target parts
Cleaning	Several times a day	Cleaning the fixture	Entire fixture
Electrode deterioration check	Before using the fixture for the first time after delivery/After replacement of parts	Acquisition of reference values *1	Center electrode, Electrode plate
	Once a day/Before fixture compensation	Determining the deviation from reference values *1	Center electrode, Electrode plate
Replacement of parts	When deterioration check result is unacceptable	Changing the orientation of the contact assembly, or replacement of parts	Center electrode, Electrode plate
			Shorting bar
Assembly check	After replacement of parts	Evaluation of absolute Ls and Rs values	Center electrode, Electrode plate
			Shorting bar

\*1. For details, see [“Acquiring Reference Values” on page 57](#).

Maintenance of the fixture is important especially to ensure fine or highly accurate measurement, since deteriorated measurement performance of the fixture has a significant effect on the measurement results. Depending on the required measurement performance, it may be necessary to increase the frequency of maintenance and/or adopt more strict criteria for each maintenance item.

The electrodes and shorting bars are consumable. Of all the fixture components, these parts are most likely to affect the measurement results. The electrodes tend to deteriorate gradually since they can easily be smeared with solder transferred from the DUT during measurements. Because shorting bars are used to determine the zero reference for fixture

compensation, smeared or deformed shorting bars can directly influence measurement results. This chapter describes the general user maintenance requirements, focusing primarily on the electrodes and shorting bars.

---

## Cleaning

Smearred electrodes result in poor measurement accuracy and repeatability. Periodically clean the electrodes to ensure accurate measurements.

### Areas Requiring Cleaning

The following areas require cleaning.

- The area of the center electrode that will be in contact with the electrode of the DUT
- The area of the electrode plate that will be in contact with the electrode of the DUT

**Figure 4-1**

**Areas Requiring Cleaning**

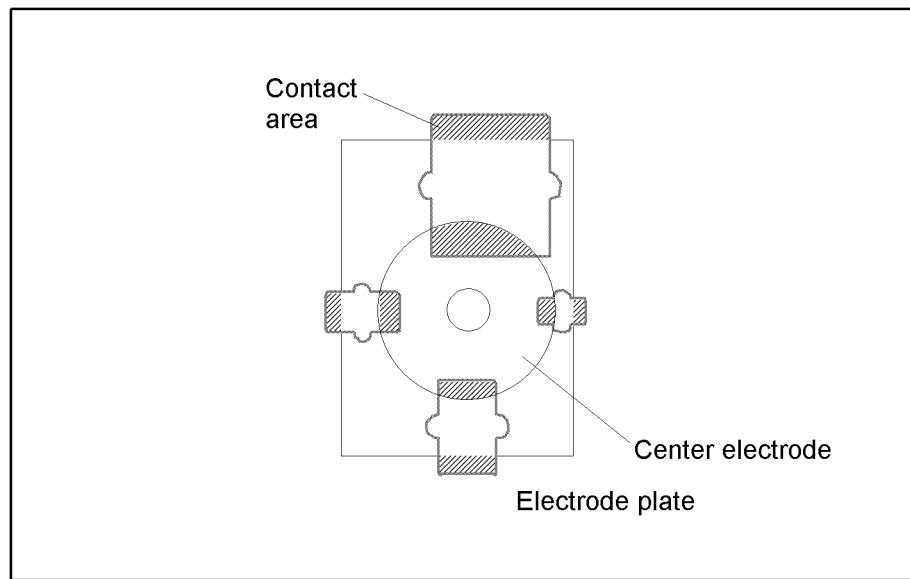

### Cleaning Method

Use a cleaning rod (Keysight part number: 5182-7586) to clean the electrodes. Remove smears on the above-mentioned contact area by wiping with the white rubber portion of the cleaning rod. Take care not to damage the electrode parts.

**Figure 4-2**

**Cleaning Rod**

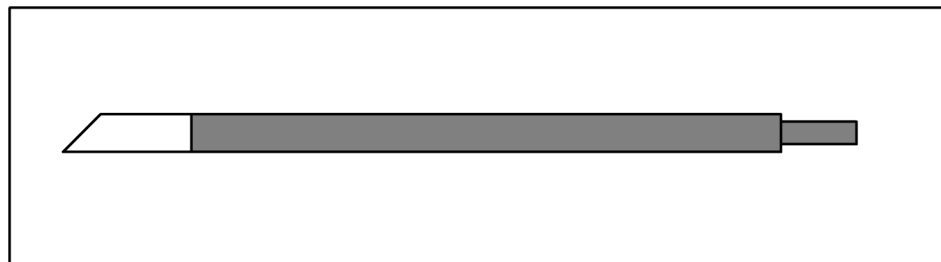

16196abccj0501



---

**CAUTION** Do not file off the smears; filing part surfaces may cause poor measurement accuracy or repeatability.

---

---

**NOTE** If smears cannot be removed, replace the part. For the replacement method, see [“Changing the Orientation of or Replacing the Contact Assembly”](#) on page 74.

---

## Deterioration Check

A deterioration check must be performed to determine the state of deterioration of the fixture and to confirm whether the fixture is providing the required measurement accuracy. The deterioration check comprises three operations: "Setting user limit values," "Acquiring Reference Values," and "Electrode Deterioration Check". In the deterioration check, the impedance values (Rs, Ls) of the fixture itself are measured at a discretionary frequency. It is recommended to use the frequency at which the fixture is normally used.

Perform "Setting user limit values" in the following cases:

- When using the fixture for the first time after delivery
- When changing the required measurement accuracy

Perform "Acquiring Reference Values" in the following cases:

- When using the fixture for the first time after delivery
- After replacing parts

Perform "Electrode Deterioration Check" in the following cases:

- Once a day, and before conducting fixture compensation

## Example Settings of User Limit Values

User limit values for the deterioration check should be set appropriately according to the type of DUT, required measurement accuracy, and so on. Example settings of user limit values are shown below.

**To evaluate an inductor (L: 10 nH, Q: 10) at a frequency (f) of 100 MHz with a measurement accuracy of around 20%:**

L:	10 nH
Q:	10
Frequency:	100 MHz
Required measurement accuracy:	20% for both L and Q

The reactance  $X$  and resistance  $R$  of the inductor under the above-mentioned conditions can be obtained as follows:

$$R = X/Q = 0.6 \Omega$$

$$X = 2\pi fL = 6 \Omega$$

Therefore,  $Q = X/R = 2\pi fL/R$ . Accordingly, if  $R$  fluctuates by 20% (120 m $\Omega$ ),  $Q$  will change by about 20%; and if  $L$  fluctuates by 20% (2 nH), both  $L$  and  $Q$  will change by about 20%. In other words, to measure  $L$  and  $Q$  at an accuracy of 20% or less error, errors in  $L$  and  $R$  must be 2 nH and 120 m $\Omega$  at the most, respectively. Considering that both  $L$  and  $R$  may fluctuate, and allowing for possible causes of error other than a deteriorated fixture, the errors must be set smaller than the above-mentioned values. For the present example, with the error set at 25% for both  $L$  and  $R$ , the user limit values for  $L$  and  $R$  are set at 500 pH and 30 m $\Omega$ , respectively.

---

**NOTE** Note that the above settings are just an example. Actually, user limit values should be varied depending on the measuring conditions and type of DUT.

---

**NOTE** In actual measurement, some of the effect of electrode deterioration is canceled by SHORT compensation. However, it is recommended to set user limit values on the assumption that deviations from the reference values affect the entire measurement results, as shown in the above example.

---

Record the user limit values in the “Check Sheet” on page 60. For the method of recording, see “Example Entry in Check Sheet” on page 59.

### Acquiring Reference Values

To obtain reference values, measure the impedance (Rs, Ls) of the fixture before deterioration. It is recommended to take measurements at a frequency at which the fixture is normally used. It is necessary to obtain reference values using electrodes and shorting bars for all sizes of DUTs that will be subject to actual measurement.

"Acquiring reference values" is necessary in the following cases:

- When using the fixture for the first time after delivery
  - After replacement of parts
- Necessary equipment**
- Shorting bars (supplied as accessories)
  - Impedance measuring instrument (calibrated at the 7-mm connector end)

---

**CAUTION** Set the fixture compensation for the measuring instrument to OFF.

---

**CAUTION** Check that each shorting bar is not deformed or stained.

---

### Procedure for Acquiring Reference Values for the Electrode Deterioration Check

- Step 1.** Clean each electrode and shorting bar using the method described in “Cleaning” on page 54.
- Step 2.** At the actual DUT measurement position, connect an appropriate shorting bar with the electrode to set the fixture for the SHORT state (See Figure 3-16 on page 45).
- Step 3.** Measure Rs and Ls according to the Operation and Service Manual for the measuring instrument.
- Step 4.** Record the Rs and Ls readings as reference values in the “Check Sheet” on page 59.
- Step 5.** From the reference values and the user limit values determined in the preceding section, calculate the upper and lower limit values, and record them in the Check Sheet.

### Electrode Deterioration Check

Measure the impedance of the fixture in the SHORT state to check for electrode deterioration. Use a shorting bar suited to the size of the actual DUT.

The electrode deterioration check is necessary in the following cases:

User Maintenance  
**Deterioration Check**

- Once a day, and before conducting fixture compensation

**Necessary equipment**

---

- Shorting bars (supplied as accessories)
- Impedance measuring instrument (calibrated at the 7-mm connector end)

**CAUTION**

---

Set the fixture compensation of the measuring instrument to OFF. Set all other functions to the same states according to "Acquiring Reference Values."

**Electrode Deterioration Check Procedure**

- Step 1.** Clean each electrode and shorting bar using the method described in [“Cleaning” on page 54](#).
- Step 2.** Perform the measurement, with the measuring instrument set for the same conditions as mentioned in [“Procedure for Acquiring Reference Values for the Electrode Deterioration Check” on page 57](#).
- Step 3.** Record the Rs and Ls readings, as well as their acceptability, in the [“Check Sheet” on page 59](#).
- Step 4.** If the results are unacceptable, replace the center electrode or the electrode plate.

**CAUTION**

---

By changing the orientation of the contact assembly, it is possible to take measurements using an unused clean area of the center electrode. For details, see [“Changing the Orientation of or Replacing the Contact Assembly” on page 74](#).

**CAUTION**

---

An electrode deterioration check using a deformed or stained shorting bar may produce unacceptable check results. Replace the shorting bar if it is deformed or if it cannot be cleaned.

## Check Sheet

### Example Entry in Check Sheet

The following tables show an example entry of electrode deterioration check results in the Check Sheet.

### Example Entry of Electrode Deterioration Check Results

DUT size 2012

**Table 4-2 Example Entry of Reference Values and User Limit Values**

Frequency *1	Measurement parameter	Reference value *2 [a]	User limit value *3 [b]	Lower limit [a-b]	Upper limit [a+b]
100 MHz	Rs	40 mΩ	30 mΩ	10 mΩ	70 mΩ
	Ls	2.34 nH	0.5 nH	1.84 nH	2.84 nH
800 MHz	Rs	220 mΩ	40 mΩ	180 mΩ	260 mΩ
	Ls	2.32 nH	0.4 nH	1.92 nH	2.72 nH

\*1. User's discretionary value

\*2. Enter the values obtained in section “Acquiring Reference Values” on page 57.

\*3. For entry, see “Example Settings of User Limit Values” on page 56.

**Table 4-3 Example Entry of Checking History**

Date/Time	Frequency	Measurement parameter	Measurement value	Acceptability	Set position of pressure adjusting nut
2000/10/11 9:30	100 MHz	Rs	50 mΩ	O	
		Ls	2.5 nH	O	
2000/10/11 9:35	800 MHz	Rs	250 mΩ	O	
		Ls	2.6 nH	O	
2000/10/12 9:30	100 MHz	Rs	55 mΩ	O	
		Ls	2.6 nH	O	
2000/10/12 9:35	800 MHz	Rs	285 mΩ	X*1	
		Ls	2.7 nH	O	

\*1. Replace parts if check results are not acceptable.

User Maintenance  
Check Sheet

**Electrode Deterioration Check**

DUT size \_\_\_\_\_

**Table 4-4 Reference Values and User Limit Values**

Frequency	Measurement parameter	Reference value [a]	User limit value [b]	Lower limit [a-b]	Upper limit [a+b]
	Rs	mΩ	mΩ	mΩ	mΩ
	Ls	pH	pH	pH	pH
	Rs	mΩ	mΩ	mΩ	mΩ
	Ls	pH	pH	pH	pH

**Table 4-5 Checking History**

Date/Time	Frequency	Measurement parameter	Measurement value	Acceptability	Set position of pressure adjusting nut
		Rs	mΩ		
		Ls	pH		
		Rs	mΩ		
		Ls	pH		
		Rs	mΩ		
		Ls	pH		
		Rs	mΩ		
		Ls	pH		
		Rs	mΩ		
		Ls	pH		
		Rs	mΩ		
		Ls	pH		
		Rs	mΩ		
		Ls	pH		
		Rs	mΩ		
		Ls	pH		
		Rs	mΩ		
		Ls	pH		

**Table 4-5                  Checking History**

<b>Date/Time</b>	<b>Frequency</b>	<b>Measurement parameter</b>	<b>Measurement value</b>	<b>Acceptability</b>	<b>Set position of pressure adjusting nut</b>
		Rs	mΩ		
		Ls	pH		
		Rs	mΩ		
		Ls	pH		

## **Assembly Check**

Each time after replacing a part, conduct an assembly check to confirm that the fixture has been assembled properly. The procedure for performing an assembly check is identical with that for an operation check. For the procedure, see **“Operation Check” on page 76** in Chapter 6.



---

# 5

## **Specifications and Supplemental Performance Characteristics**

This chapter provides specifications and supplemental performance characteristics of the 16197A test fixture.

## **Definitions**

**Specification (spec.):** Warranted performance. Specifications include guardbands to account for the expected statistical performance distribution, measurement uncertainties, and changes in performance due to environmental conditions.

Supplemental Information is intended to provide information useful in applying the instrument, but that is not covered by the product warranty. The information is denoted as typical, or nominal.

**Typical (typ.):** Expected performance of an average unit which does not include guardbands.

**Nominal (nom.):** A general, descriptive term that does not imply a level of performance.

## Specifications

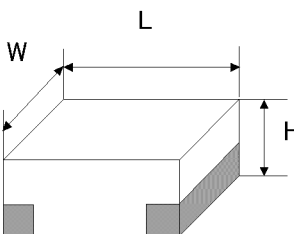
Applicable Instruments	Refer to the <a href="#">Table 1-2</a> and <a href="#">Table 1-3</a> on page 18.															
Applicable DUT Type	Surface Mount Device with bottom electrodes.															
Applicable DUT Size		<table border="0"> <thead> <tr> <th>Model</th> <th>Length (L) × Width (W) × Height (H)</th> </tr> </thead> <tbody> <tr> <td>3225</td> <td><math>(3.2 \pm 0.15) \times (2.5 \pm 0.15) \times (\geq 0.4)</math> mm</td> </tr> <tr> <td>3216</td> <td><math>(3.2 \pm 0.15) \times (1.6 \pm 0.15) \times (\geq 0.4)</math> mm</td> </tr> <tr> <td>2012</td> <td><math>(2.0 \pm 0.1) \times (1.25 \pm 0.1) \times (\geq 0.4)</math> mm</td> </tr> <tr> <td>1608</td> <td><math>(1.6 \pm 0.15) \times (0.8 \pm 0.15) \times (\geq 0.4)</math> mm</td> </tr> <tr> <td>1005</td> <td><math>(1.0 \pm 0.03) \times (0.3 \pm 0.03) \times (\geq 0.4)</math> mm</td> </tr> <tr> <td>0603</td> <td><math>(0.6 \pm 0.03) \times (0.3 \pm 0.03) \times (\geq 0.25)</math> mm</td> </tr> </tbody> </table>	Model	Length (L) × Width (W) × Height (H)	3225	$(3.2 \pm 0.15) \times (2.5 \pm 0.15) \times (\geq 0.4)$ mm	3216	$(3.2 \pm 0.15) \times (1.6 \pm 0.15) \times (\geq 0.4)$ mm	2012	$(2.0 \pm 0.1) \times (1.25 \pm 0.1) \times (\geq 0.4)$ mm	1608	$(1.6 \pm 0.15) \times (0.8 \pm 0.15) \times (\geq 0.4)$ mm	1005	$(1.0 \pm 0.03) \times (0.3 \pm 0.03) \times (\geq 0.4)$ mm	0603	$(0.6 \pm 0.03) \times (0.3 \pm 0.03) \times (\geq 0.25)$ mm
Model	Length (L) × Width (W) × Height (H)															
3225	$(3.2 \pm 0.15) \times (2.5 \pm 0.15) \times (\geq 0.4)$ mm															
3216	$(3.2 \pm 0.15) \times (1.6 \pm 0.15) \times (\geq 0.4)$ mm															
2012	$(2.0 \pm 0.1) \times (1.25 \pm 0.1) \times (\geq 0.4)$ mm															
1608	$(1.6 \pm 0.15) \times (0.8 \pm 0.15) \times (\geq 0.4)$ mm															
1005	$(1.0 \pm 0.03) \times (0.3 \pm 0.03) \times (\geq 0.4)$ mm															
0603	$(0.6 \pm 0.03) \times (0.3 \pm 0.03) \times (\geq 0.25)$ mm															
Frequency	DC to 3 GHz															
Maximum Voltage	± 40V peak max. (AC+DC)															
Maximum Current	5 A															
Operating Environment	temp.	-55°C to +85°C														
	humidity	15% to 95%RH (@ wet bulb temp. < 40°C)														
Non Operating Environment	temp.	-55°C to +85°C														
	humidity	≤ 90 % RH (@ wet bulb temp. <65°C)														
Dimension	Approximately 160 (W) × 86 (D) × 70 (H) mm ( <b>nom.</b> )															
Weight	Approximately 300 g ( <b>nom.</b> )															
Safety Standards	EN61010-1:1993 +A2:1995 IEC61010-1:1990 +A1:1992 +A2:1995 CAN/CSA C22.2 No.1010.1-92  INSTALLATION CATEGORY I POLLUTION DEGREE 2 INDOOR USE															

## Supplemental Performance Characteristics

This section provides useful data on the 16197A. These supplemental performance characteristics should not be considered specifications.

### Additional Error

Additional errors are calculated as follows.

#### **|Z| Measurement**

Additional error for Impedance  $Z_e$  [%] is calculated by substituting the values in the table below into the following equation.

$$Z_e [\%] = \pm \{A + (Z_s/Z_x + Y_o \times Z_x) \times 100\}$$

where

A [%]	Test Fixture's Proportional Error [%]
$Y_o$ [S]	Test Fixture's Open Repeatability [S]
$Z_s$ [ $\Omega$ ]	Test Fixture's Short Repeatability [ $\Omega$ ]
$Z_x$ [ $\Omega$ ]	Measured Impedance Value of DUT [ $\Omega$ ]

$Z_s$	$(30 + 150 \times f) \times 10^{-3}[\Omega]$
$Y_o$	$(2 + 30 \times f) \times 10^{-6}[S]$
A	$1.2 \times f^2 [\%]$

where  $f$  is frequency (GHz).

#### **D Measurement**

Additional error for Dissipation Factor  $D_e$  is calculated by using the additional error for Impedance  $Z_e$  [%] as follows.

If  $D_x \leq 0.1$ :

$$D_e = Z_e / 100$$

If  $0.1 < D_x \leq 0.5$ :

$$D_e = (Z_e / 100) \times (1 + D_x)$$

where  $D_x$  is the measured value of  $D$ . It is necessary for  $Z_e$  to be below 10 %.

#### **NOTE**

$D$  is not expressed as a percentage but as an absolute value.

**Rs (ESR) Measurement**

Additional error Rse[%] of the Rs measurement is calculated by using the additional error for Impedance Ze [%] as follows.

If  $D_x \leq 0.1$ :

$$Rse [\%] = Ze / D_x$$

If  $0.1 < D_x \leq 0.5$ :

$$Rse [\%] = (Ze / D_x) \times \sqrt{1 + D_x^2}$$

$D_x$  is the measured value of  $D$  and is calculated as follows.

$$D_x = 2 \times \pi \times f \times C_{sx} \times R_{sx},$$

where

f: measurement signal frequency

$C_{sx}$ : measured value of  $C_s$

$R_{sx}$ : measured value of  $R_s$ .

**Figure 5-1 Additional Error for Impedance**

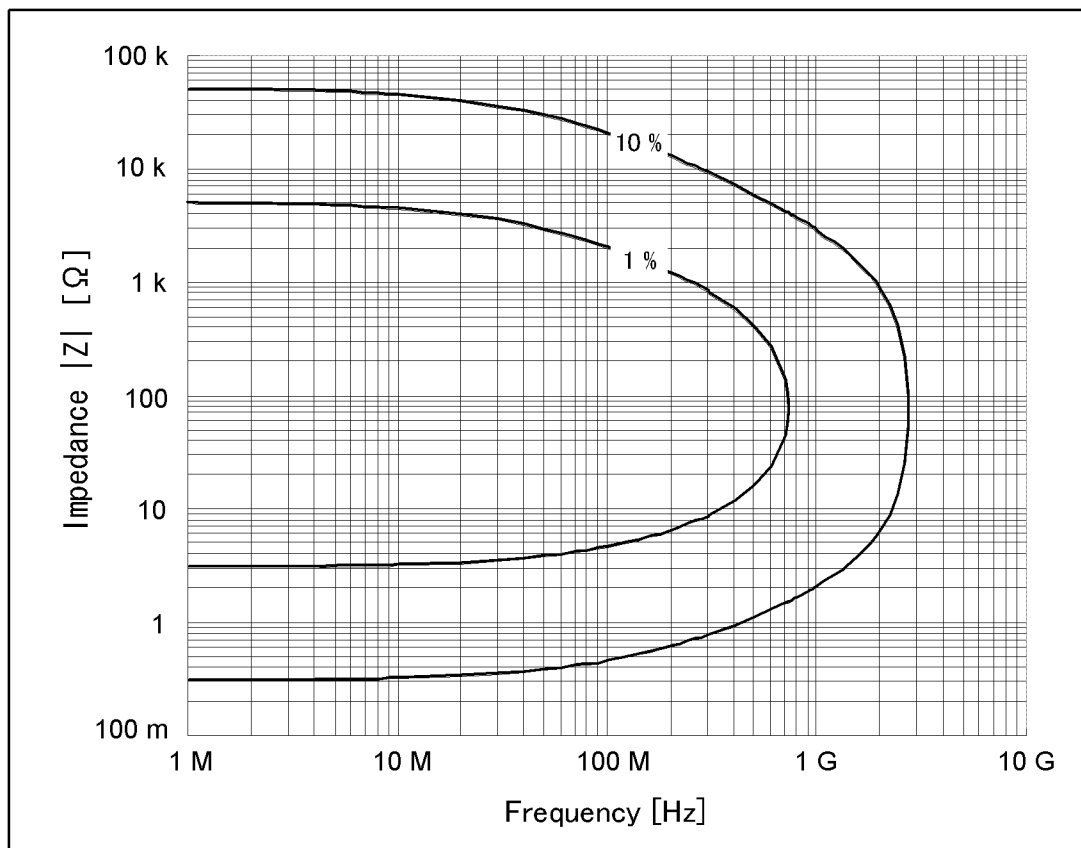

## Residual Inductance of the Shorting Bar

The usual method to compensate the test fixture's residual inductance is to let SHORT = 0H. In this method, the measurement result is the relative value of the measured impedance to the shorting bar's impedance. The short bar's residual inductance as a result of its size and shape is not estimated.

On the other hand, there is a definition method to let SHORT = x H. In this method, the measurement result is the absolute value of the device's impedance. The short bar's residual inductance as a result of its size and shape is estimated under specific conditions and is used as a reference value. This method, is useful for devices with values which are close to the short conditions of the measurement system.

The reference inductance values presented [Table 5-1](#) were simulated as the relative difference to a disk-type 0 Ω termination on either the 7mm or the 3.5mm connector. The measurement of these short bars under other conditions than shown below cannot reproduce the reference inductance values.

**Table 5-1 Residual Inductance (Typical)**

Shorting Bar Set	l [mm]	d [mm]	h [mm]	Offset [mm]	Connector	Inductance (Typical)
0.6 × 0.3 × 0.3	0.6	0.3	0.3	0.0585	1 mm	0.1 nH
1.0 × 0.5 × 0.5	1.0	0.5	0.5	0.75	3.5 mm	0.5 nH
1.6 × 0.8 × 0.8	1.6	0.8	0.8	0.45	3.5 mm	0.4 nH
2.0 × 1.2 × 0.8	2.0	1.2	0.8	1.5	7 mm	0.9 nH
3.2 × 1.6 × 0.8	3.2	1.6	0.8	0.9	7 mm	0.8 nH

**Figure 5-2 Simulation Setup**

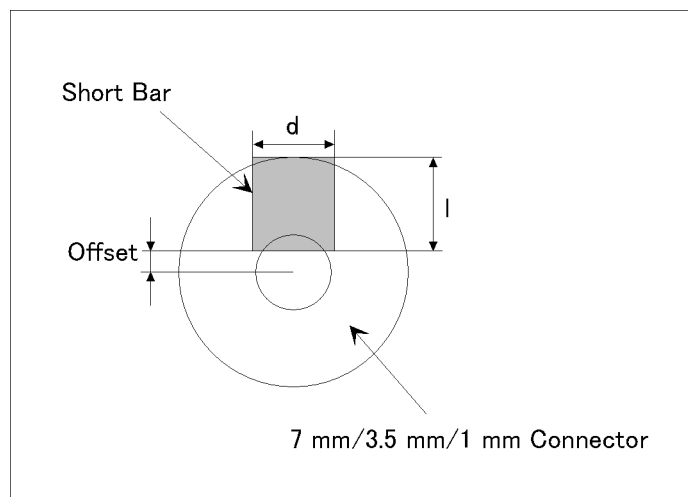

---

# 6

# Service

This chapter describes the replaceable parts of the fixture, and the method for replacing parts.

## Replaceable Parts

Confirm the part number of each replaceable part with the exploded views and tables shown below. Do not disassemble each unit into smaller components than shown in these exploded views.

In placing an order for each replaceable part, designate the corresponding Keysight part number and check digit (C/D). If a defective part to be replaced is part of a component that cannot be disassembled, place an order for the entire component. Defective parts or components may be sent to Keysight Technologies local sales/service office for repair.

## Pressure Unit

Figure 6-1

Exploded View of Pressure Unit Assembly

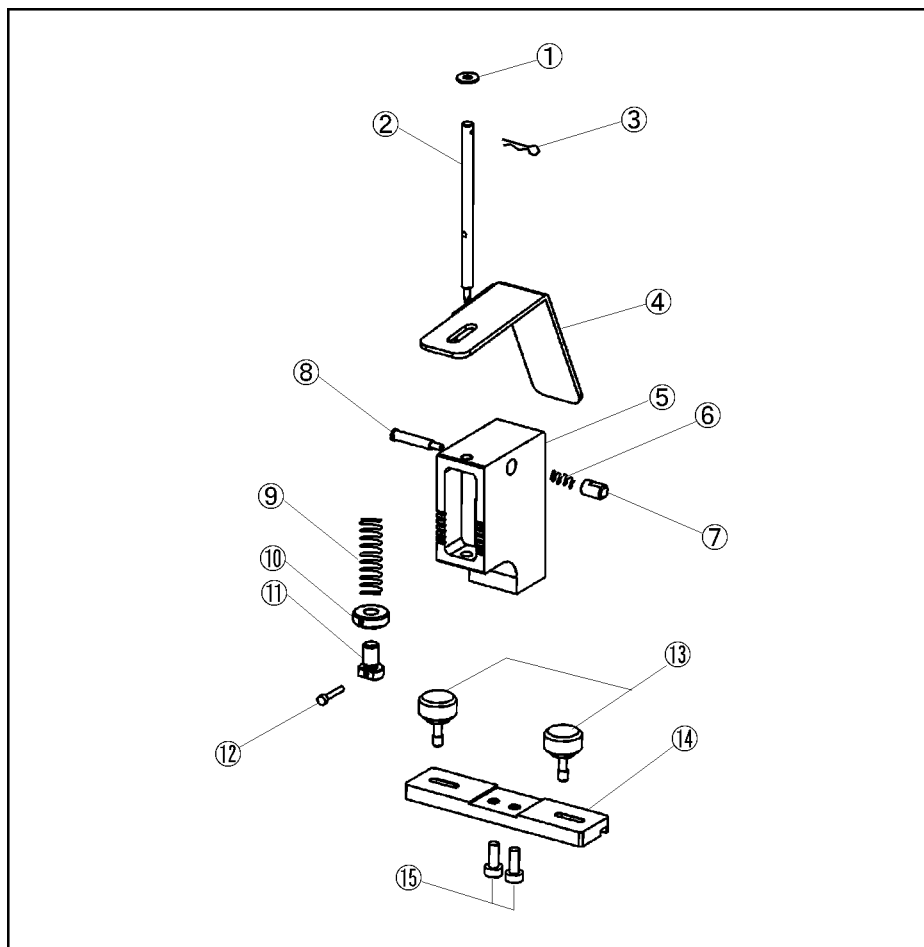

16197a0j0601



**Table 6-1                      Replaceable Parts (Pressure Unit)**

<b>No.</b>	<b>Keysight part number</b>	<b>C/D</b>	<b>Qty</b>	<b>Description</b>
1	3050-1138	7	1	Washer
2	16197-25002	9	1	Pressure rod
3	1480-1093	2	1	R-pin
4	16197-05001	6	1	Lever
5	N/A	8	1	Pressure unit
6	1460-2662	1	1	Spring
7	16197-23003	6	1	Shaft
8	16197-23004	7	1	Shaft
9	1460-2663	2	1	Spring
10	16197-24004	9	1	Pressure adjusting nut
11	16197-24005	0	1	Screw
12	0515-1185	7	1	Screw
13	16197-24003	8	2	Knob
14	N/A	7	1	Sliding block
15	0515-1550		2	Screw M3

Service  
**Replaceable Parts**

**Electrode Unit**

Figure 6-2

**Exploded View of Electrode Unit Assembly**

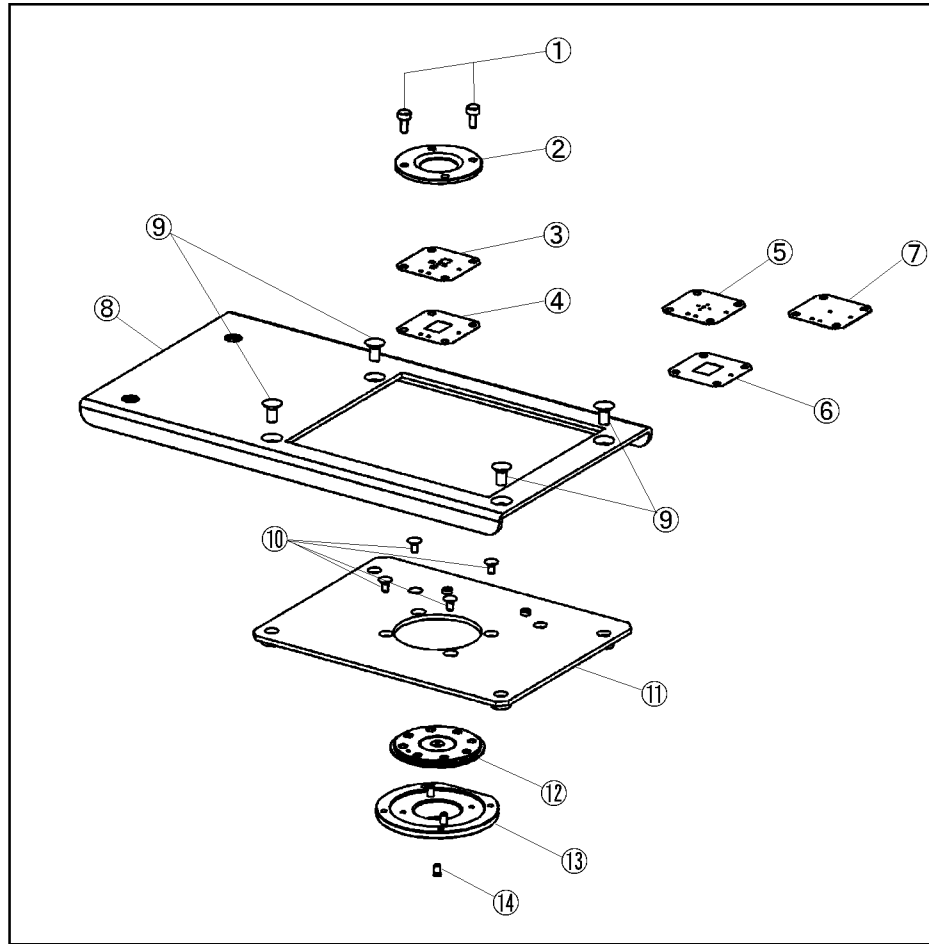

16197aoj0602

Table 6-2

**Replaceable Parts (Electrode Unit)**

No.	Keysight part number	C/D	Qty	Description
1	0515-1077	6	2	Screw M-2.0
2	16197-25004	1	1	Guide holder
3	16197-25005	2	1	Device guide
4	16197-00603	4	1	Electrode plate
5	16197-25007	4	1	Device guide (for Option 001)
6	16197-00604	5	1	Electrode plate (for Option 001)
7	16197-25006	3	1	Device guide (blank)
8	16197-00601	2	1	Plate

**Table 6-2**                      **Replaceable Parts (Electrode Unit)**

No.	Keysight part number	C/D	Qty	Description
9	0515-0914	8	4	Screw M3 × 0.5
10	0515-0952	4	4	Screw M2 × 0.4
11	N/A	3	1	Plate
12	16197-60001	2	1	Contact assembly (including contact center)
13	16197-24001	6	1	Flange
14	1250-0907	8	1	Contact center

**Other Parts**

**Table 6-3**                      **Replaceable Parts (Other Parts)**

No.	Keysight part number	C/D	Qty	Description
1	16191-29005	4	1	Shorting bar 1.0 × 0.5
2	16191-29006	5	1	Shorting bar 1.6 × 0.8
3	16191-29007	6	1	Shorting bar 2.0 × 1.2
4	16191-29008	7	1	Shorting bar 3.2 × 1.6
5	16197-29001	6	1	Shorting bar (for Option Kit 001)
6	8710-2081	6	1	Tweezers
7	8710-0909	3	1	Allen wrench
8	16193-60002	9	1	Magnifying glass
9	16197-60050	1	1	Carrying case

## Changing the Orientation of or Replacing the Contact Assembly

If the center electrode of the contact assembly is smeared, an unused clean area of the center electrode can be used simply by changing the orientation of the contact assembly. This section describes the method for changing the orientation of or replacing the contact assembly.

To change the contact assembly orientation or replace the contact assembly, it is necessary to use a 1.5-mm Allen wrench (Keysight part number: 8710-0909) and a Phillips screwdriver.

### Procedure for Changing the Orientation of or Replacing the Contact Assembly

1. Take off the guide holder, and remove the device guide and electrode plate. (See to [Figure 3-4 on page 36](#)).
2. Remove the four screws from the upper side of the fixture, and then remove the contact assembly and flange.

**Figure 6-3** Removing the Contact Assembly

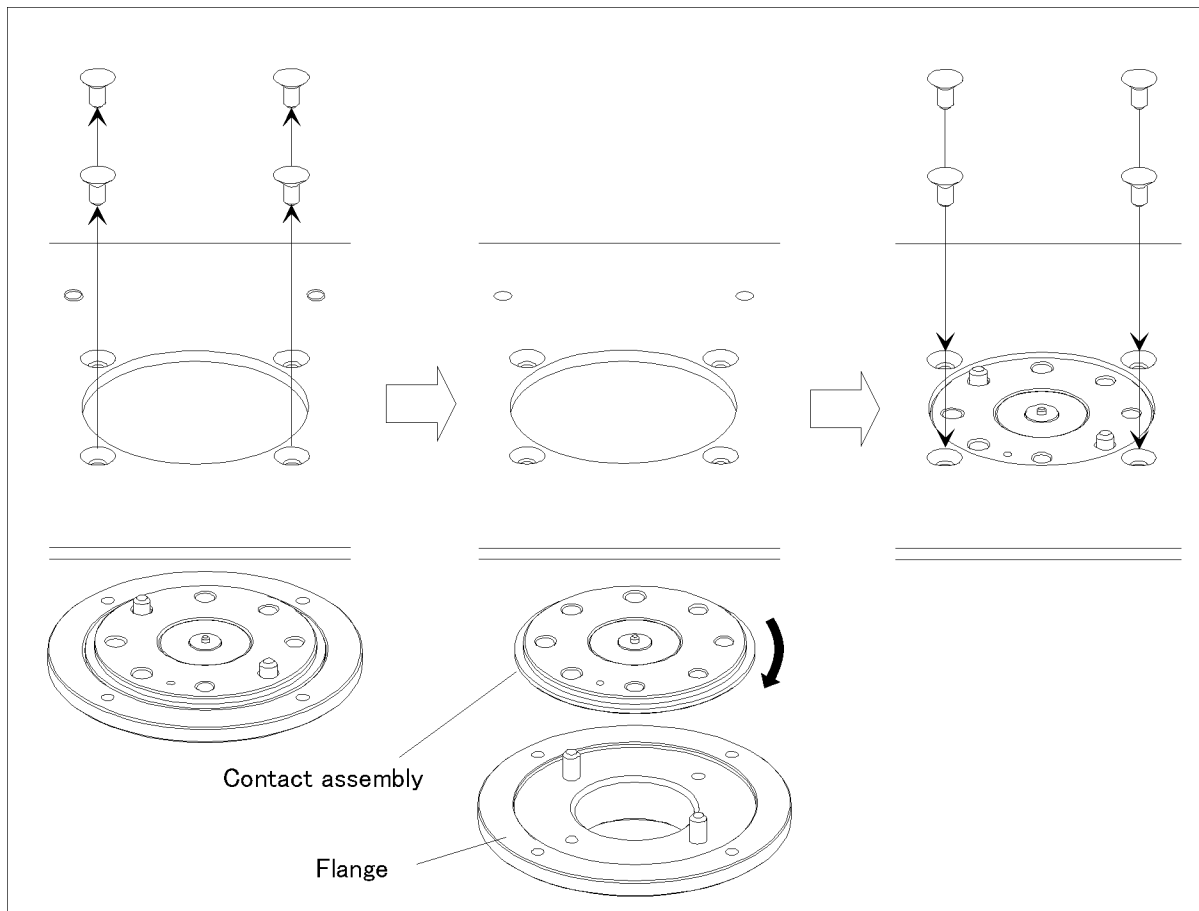

**Changing the Orientation of or Replacing the Contact Assembly**

3. Rotate the contact assembly and set it in place so that a clean area of the center electrode is at the measuring position.
4. Install the flange, and tighten the screws.
5. Install the device guide and electrode plate. Then mount the guide holder and secure it with the screws.

---

## Operation Check

This section describes the operation check method. Be sure to perform the operation check after each time a part is replaced.

### Open Impedance Check

Conduct an Open impedance check with the fixture set for the OPEN state.

#### Necessary equipment

- Shorting bars (supplied as accessories)
- Impedance measuring instrument (calibrated at the 7-mm connector end)

---

#### NOTE

If a measuring instrument other than the 4291B is to be used, make the equivalent settings according to the Operation and Service Manual for the instrument to be used.

- Step 1.** Prepare a measuring instrument calibrated at the 7-mm connector end. Connect the test fixture with this instrument.
- Step 2.** Set the fixture for the OPEN state, at the DUT measuring position (see [Figure 3-18 on page 47](#)).
- Step 3.** Make the settings for the 4291B as follows.

Table 6-4

**Settings for the Measuring Instrument (Keysight 4291B)**

Measuring condition	Setting
Measurement parameter	Cp
Start frequency	100 MHz
Stop frequency	1 GHz
OSC Level	0.5 V
Number of points	2
Point averaging factor	16
Point averaging	ON

- Step 4.** Under these conditions, measure Cp at 100 MHz and 1 GHz, separately.
- Step 5.** Confirm that the Cp value is within the typical range shown in [Table 6-5](#).

Table 6-5

**OPEN Impedance Check: Typical**

Parameter	Frequency	Typical (Absolute value)
Cp	100 MHz	700 fF ± 400 fF
Cp	1 GHz	700 fF ± 400 fF

### Short Impedance Check

Upon completion of the open impedance check, carry out a short impedance check with the fixture set for the SHORT state.

- Step 6.** At the DUT measuring position, connect an appropriate shorting bar with the electrode to secure the fixture for the SHORT state. (See [Figure 3-16 on page 45](#)).
- Step 7.** Make the settings for the 4291B as follows.

**Table 6-6**

**Settings for the Measuring Instrument (Keysight 4291B)**

Measuring condition	Setting
Measurement parameter	Ls
Start frequency	100 MHz
Stop frequency	1 GHz
OSC Level	0.5 V
Number of points	2
Point averaging factor	16
Point averaging	ON

- Step 8.** Under this condition, measure Ls at 100 MHz and 1 GHz, separately.
- Step 9.** Confirm that the Ls value is within the typical range shown in [Table 6-7](#).

**Table 6-7**

**Short Impedance Check: Typical**

Parameter	Frequency	Typical (Absolute value)
Ls	100 MHz	2.3 nH $\pm$ 1 nH <sup>*1</sup>
Ls	1 GHz	2.3 nH $\pm$ 1 nH <sup>*1</sup>

\*1. The values given above are common to shorting bars of all sizes.

### Short-impedance Measurement Repeatability Check

Repeat short impedance measurement to check for the repeatability of measurement.

- Step 1.** Upon completion of the short impedance check, disconnect the shorting bar and connect it again with the electrode.
- Step 2.** Under the same measuring conditions as given above, measure Ls again at 100 MHz and 1 GHz, separately.
- Step 3.** Confirm that the Ls value is within the typical range shown in [Table 6-7](#).
- Step 4.** Obtain the difference between the first and second Ls measurements.

Service  
**Operation Check**

**Step 5.** Confirm that the variation in measurements is within the typical range shown in [Table 6-8](#).

**Table 6-8**

**Short-impedance Measurement Repeatability Check: Typical**

<b>Parameter</b>	<b>Frequency</b>	<b>Typical (Difference)</b>
Ls	100 MHz	± 45 pH
Ls	1 GHz	± 20 pH



---

## A Manual Changes

This appendix contains the information required to adapt this manual to versions or configurations of the 16197A manufactured earlier than the current printing date of this manual. The information in this manual applies directly to 16197A units with the serial number that is printed on the title page of this manual.

## Manual Changes

To adapt this manual to your 16197A, refer to [Table A-1](#).

**Table A-1** **Manual Changes by Serial Number**

Serial Prefix or Number	Make Manual Changes

Keysight Technologies uses a two-part, ten-character serial number that is stamped on the serial number plate ([Figure A-1](#)). The first five characters are the serial prefix and the last five digits are the suffix.

**Figure A-1** **Serial Number Plate**



---

**Numerics**

- 1005
  - measuring position, 24
- 1608
  - measuring position, 24
- 2012
  - measuring position, 24
- 2520
  - example of preparing device guide, 41
  - example of preparing simple device guide, 42
- 3216
  - measuring position, 24
- 3225
  - measuring position, 24

**A**

- accessories, 26
- adapter, 18
- Additional Error, 66
- Allen wrench
  - names & functions, 26
  - package contents, 12
- applicable chip (example), 33
- assembly, 13
- assembly check, 62
  - maintenance outline, 52

**B**

- blank device guide
  - dimensional drawing, 39
  - names & functions, 26
  - package contents, 12

**C**

- calibration
  - measurement flow, 30
- center electrode
  - structure of electrode, 23
- check sheet
  - example entry, 59
- cleaning, 52, 54
  - areas requiring cleaning, 54
  - maintenance outline, 52
  - method, 54
- cleaning rod, 54
- connecting a DUT
  - mechanism, 23
  - structure of electrode, 24
- contact assembly
  - changing the orientation or replacing, 74

**D**

- deterioration check, 56
  - acquiring reference values, 57
- device

- measuring position, 24
- device guide
  - changing the orientation or replacing, 35
  - example of preparation, 40
  - mounting, 37
  - names & functions, 26
  - package contents, 12
  - removal, 36
  - simple device guide, 42
  - structure of electrode, 23
- device holder
  - inside diameter, 40
- device hole
  - dimensions, 34
- Dimension, 65
- DUT
  - connecting, 48

**E**

- electrical length
  - setting, 32
- electrode
  - structure, 23
  - positioning, 39
  - spacing, 34
  - structure, 23
- electrode deterioration check, 57
  - check sheet, 60
  - example entry, 59
  - maintenance outline, 52
- electrode plate
  - changing the orientation or replacing, 35
  - mounting, 37
  - names & functions, 26
  - package contents, 12
  - removal, 36
  - structure of electrode, 23
- electrode unit
  - names & functions, 25
  - replaceable parts, 72

**F**

- fixture compensation, 43
- frame
  - selection, 33
  - structure of electrode, 23
- Frequency
  - Specifications, 65

**G**

- guide holder
  - names & functions, 25
- guide holder fixing screws
  - changing positions, 16
- guide hole
  - data for preparation, 39

## I

inspection before unpacking, 10  
insulator assembly  
  mounting, 43  
  specification, 33

## K

knob  
  names & functions, 25

## L

latch  
  names & functions, 25  
lever  
  names & functions, 25

## M

magnifying glass  
  package contents, 12  
  installation, 14  
  names & functions, 26  
Maintenance items, 52  
manual changes, 79  
Maximum Current, 65  
Maximum Voltage, 65  
measurement flow, 30

## N

Nominal, 64  
Non Operating Environment, 65

## O

OPEN compensation, 47  
open impedance check, 76  
Open Repeatability, 66  
Operating Environment, 65  
operation check, 76

## P

package contents, 11  
pressure adjusting nut  
  adjusting method, 15  
  names & functions, 25  
pressure rod  
  movable range, 40  
  names & functions, 25  
  standby position, 46  
pressure unit  
  installation, 13  
  names & functions, 25  
  removal, 15  
  replaceable parts, 70  
product appearance, 22  
product description, 22

## R

reference values  
  acquiring, 57  
replaceable parts, 70  
  Electrode Unit, 72  
  Other Parts, 73  
  Pressure Unit, 71  
replacement of parts  
  maintenance outline, 52  
Rs  
  SHORT plate deterioration check, 58

## S

Safety Standards, 65  
Serial number plate, 80  
service, 69  
setting the measuring conditions  
  measurement flow, 30  
SHORT compensation, 43  
short impedance check, 77  
Short Repeatability, 66  
short-impedance measurement repeatability check, 77  
shorting bar  
  connecting, 44  
shorting bar set  
  names & functions, 26  
  package contents, 12  
Simple device guide  
  example of preparation, 42  
sliding block  
  names & functions, 25  
Specifications, 65  
storage, 15  
  electrode  
  structure, 23  
Supplemental Performance Characteristics, 66

## T

test fixture  
  attaching the adapter, 19  
  connecting with a measuring instrument, 18  
tweezers  
  names & functions, 26  
  package contents, 12  
Typical, 64

## U

user limit values  
  example settings, 56  
user maintenance, 51

## W

Weight, 65



This information is subject to change without notice.  
© Keysight Technologies 2001, 2008, 2011, 2015  
Edition 4, February 2015



16197-90020  
[www.keysight.com](http://www.keysight.com)