

**KB-111A**  
**Speaker Station**

INSTRUCTION  
and  
SERVICE MANUAL



945 Camelia St. Berkeley, California 94710 510-527-6666

```

*****
**          DOCUMENTATION ADDENDUM          **
**          KB-111A  MANUAL                 **
**          REV.A                           **
**          November 17, 1987              **
**                                          **
*****

```

MIC TO LINE GAIN LEVEL INCREASE

In effecting a 4dB Mic to Line increase in gain level, the following changes have been made:

<u>Change:</u>	<u>At:</u>	<u>To:</u>
270K OHM	R18, 36	390K OHM
27pf	C9	15pf
180pf	C10	100pf

CLEAR-COM KB-111A SPEAKER STATION  
INSTRUCTION & SERVICE MANUAL

TABLE OF CONTENTS

<u>Section</u>	<u>Page #</u>
I Introduction to the KB-111A.....	1
II Headsets and Mics.....	1
III Installation.....	3
IV Operating Controls.....	7
V Parts Listing.....	8
VI Specifications.....	8
VII Call Signalling Modification.....	9

Illustrations

Figure 1: Headset Y-Cable.....	2
Figure 2: Headset Extension Cord.....	2
Figure 3: KB-111A Mounting Dimensions.....	4
Figure 4: KB-111A Block Diagram.....	4
Figure 5: Two-Channel Interconnect Wiring.....	5
Figure 6: Portable Unit Connections.....	6
Figure 7: Alternative Signalling.....	9
Figure 8: KB-111A Schematic.....	10

**NOTICE:**

***"While Clear-Com makes every attempt to maintain the accuracy of the information contained in its product manuals, the information is subject to change without notice."***

## I. INTRODUCTION TO THE KB-111A REMOTE STATION

The Clear-Com KB-111A is a Remote Speaker Station that provides talk/listen communications on one of two channels within our closed-circuit intercom system. It features a wide frequency response, high output speaker and the ability to operate with a carbon headset OR a dynamic headset, handset, or push-to-talk mic.

The KB-111A features the Clear-Com contoured frequency response for consistently excellent speech intelligibility in all surroundings. The speaker delivers crisp sound pressure levels, clearly audible in high- or low-noise environments. The Remote Station features Automatic Headset Detection; its built-in mic preamp automatically shuts off when the headset is disconnected, eliminating noise pick-up on the intercom line. The intercom circuitry incorporates a mic limiter, which assures constant talk levels and prevents overload.

The KB-111A's speaker can remain on at all times, or you can turn it off so that private conversations may be carried out with a headset or telephone handset. The three-position mic switch allows you to:

- 1) keep the mic on at all times;
- 2) activate the mic momentarily;
- 3) switch off the mic so the KB-111A can function as a "listen-only" station.

## II. HEADSETS AND MICS

To provide you with the ability to talk on the intercom channel, the KB-111A contains:

- one 1/4" phone jack for a standard carbon headset, AND
- one 4-pin, male, XLR-type connector (D4M) for a dynamic headset, telephone-style handset, or push-to-talk mic

The KB-111A provides an adjustable sidetone circuit which allows you to vary the level of your voice as you hear it in your headset or speaker. The circuit also prevents feedback when using the speaker and a mic simultaneously. You need only adjust the sidetone once, even if other Stations subsequently join or leave the intercom system.

Designed for custom-mounting, the KB-111A is built on a charcoal-brown, aluminum panel, 5/32" thick, that can be installed in a cut-out in any convenient surface, or mounted inside a 6" x 8" Nema electrical enclosure. The Station connects to the intercom system via a 5-pin terminal block behind the front panel.

Clear-Com offers the "P" Box, which allows you to convert the KB-111A to a portable Remote Station. The P-Box is a sturdy, sloped-front, steel enclosure with solid walnut sides. When installed in a P-Box, the KB-111A connects to the intercom system with 3-pin, XLR connectors.

When the KB-111A is installed in the P-Box, it provides talk/listen capability on one channel.

Standard two-conductor shielded mic cable interconnects stations within the intercom system.

The KB-111A's built-in headset/speaker amplifier can drive a standard headset to levels greater than 110 dB SPL. The Station's mic preamp automatically shuts off when the headset is disconnected, thereby eliminating hum pick-up.

NOTE: If you use a carbon headset and a dynamic headset simultaneous-

ly. the listen-level in the carbon headset drops audibly.

The carbon headset connections are:

- Ring-- Headphone
- Tip-- Mic
- Sleeve-- Ground

The D4M connector pins are:

- Pin 1: Mic Ground
- Pin 2: Mic Hot
- Pin 3: Headphone Ground
- Pin 4: Headphone Hot

To assure proper level and performance, the dynamic headset should have the following characteristics:

- Microphone type: dynamic
- Impedance: 150-250 ohms
- Output level: -55 dB
- Headphone type: dynamic
- Output impedance: 300-2000 ohms

Clear-Com offers three dynamic headsets, all with boom-mounted, noise-cancelling mics. Model CC-240B is a double-muff and Model CC-75B is single-muff; both have boom-activated mics with on/off switches. Model PH-7 is a very rugged, double-muff, high-fidelity headset with wider frequency response and

greater isolation from ambient noise. Clear-Com also offers Model HS-6, a telephone-style handset with a dynamic mic and push-to-talk switch; it is interchangeable with the above headsets. All units have field-replaceable cords.

The KB-111A drives two dynamic headsets with only a slight (3 dB) reduction in level. Clear-Com can supply you with Model YC-100 "Y" Cable, which allows you to plug two headsets into the one D4M connector on the Station's front panel.

Alternately, you may construct your own Y-cable; we recommend you use Belden 8416 or the equivalent (2-conductor, 25 gauge) or Belden 8734 or the equivalent (3-conductor, 22 gauge). See Figure 1.

You can also build an extension cord for a dynamic headset, using the cable specified above. Limit its length to 15 feet or less; greater lengths lead to possible capacity coupling between the mic signal and the headset signal, which causes oscillation or a loss in frequency response. See Fig. 2.

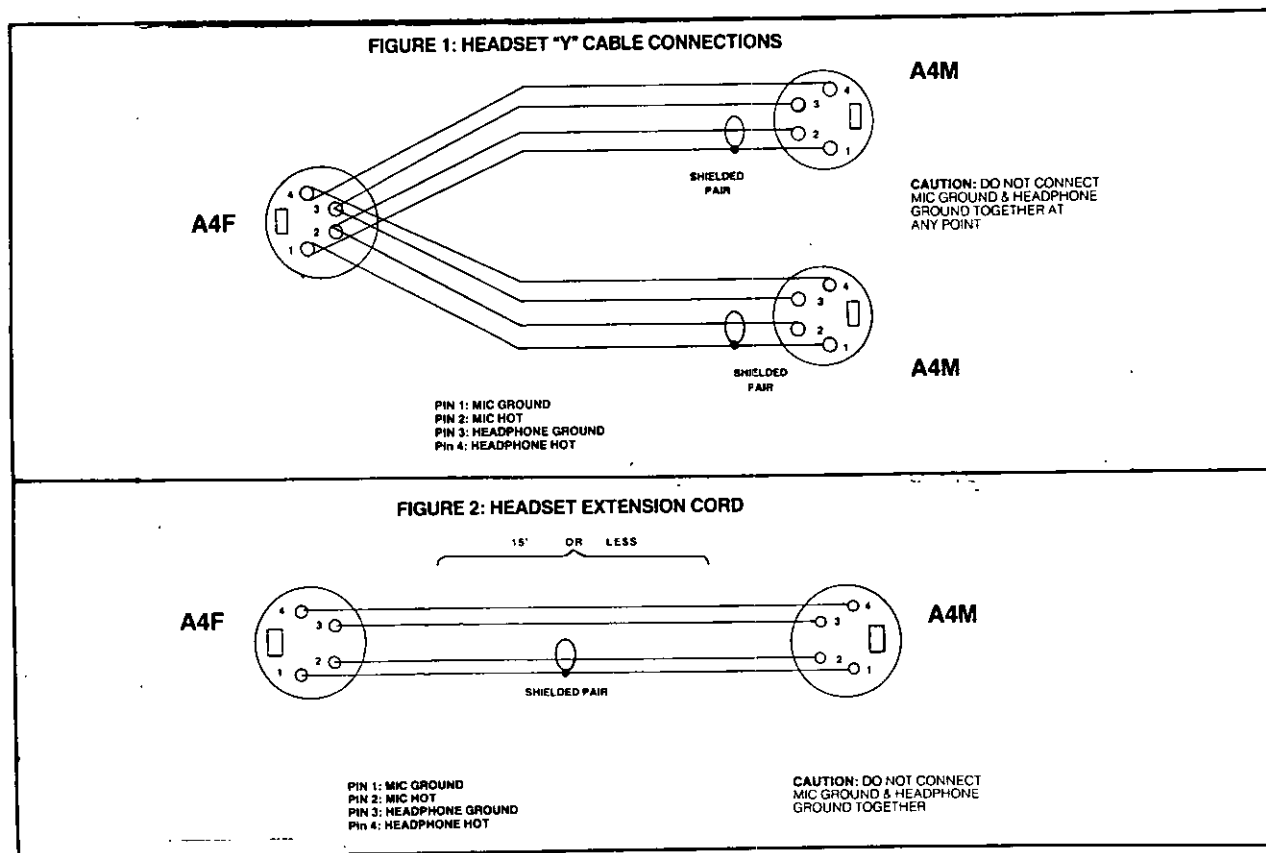

## II. KB-111A INSTALLATION

The KB-111A connects to the intercom system with a five-screw terminal strip, which is located on the PC Board. Route two-pair (individually shielded) cable (i.e. Belden 8723) from a Main Station or Power Supply output connector to the location of your Remote Station (or route two separate, two-conductor mic cables, one per channel). Each channel must be fed within its own shield, although unshielded cable may be used when run in conduit.

The KB-111A can be mounted in a cut-out in any surface, or it can mount inside a 6" by 8" Black (electrical) Box (minimum depth, 3"). See figure 3 for dimensions.

After preparing a surface for installation, bring wiring into the header on the terminal strip. While making connections, refer to the label adjacent to the terminal strip; it identifies each pin by assignment:

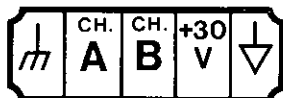

Connect the leads according to the label shown above.

**IMPORTANT** to prevent ground loops and buzzes, the common terminal (pin 5) should **NEVER** be directly connected to chassis ground (pin 1). Use conduit or a separate wire to interconnect two or more KB-111A Stations to pin 1.

If you plan to use only one channel on the KB-111A, disable the Channel Select switch by jumping Channels A and B together on the connector block, and hook the intercom audio line to either terminal 2 or 3.

If you don't disable the Channel Select switch and are only using one channel, you must be sure to keep the Channel Select switch set to the active channel. If you switch to the unconnected channel, the Station will exhibit disturbing oscillation.

See Figure 5 (page 5) for examples of KB-111A Two-Channel Wiring.

### THE PORTABLE KB-111A

The KB-111A may be mounted inside the Clear-Com Model "P" Box, thereby becoming a portable Remote Station. The "P" Box is supplied with a handle, rubber feet, and screws for attaching the handle and the intercom to the enclosure.

When the KB-111A is mounted in the P-Box, only one channel can be used for communication. The wiring in the P-Box contains a jumper to defeat the Station's Channel Select switch.

The portable Station connects to the intercom system with the 3-pin, XLR connectors located on the side of the P-Box. There is one female connector for input, and one male connector for extending the intercom line to other Remote Stations. Inside the P-Box, the connectors are wired to a 5-pin terminal strip, which you plug onto the header on the KB-111A PC Board. Refer to Figure 6, Portable Unit Connections (page 6).

--continued--

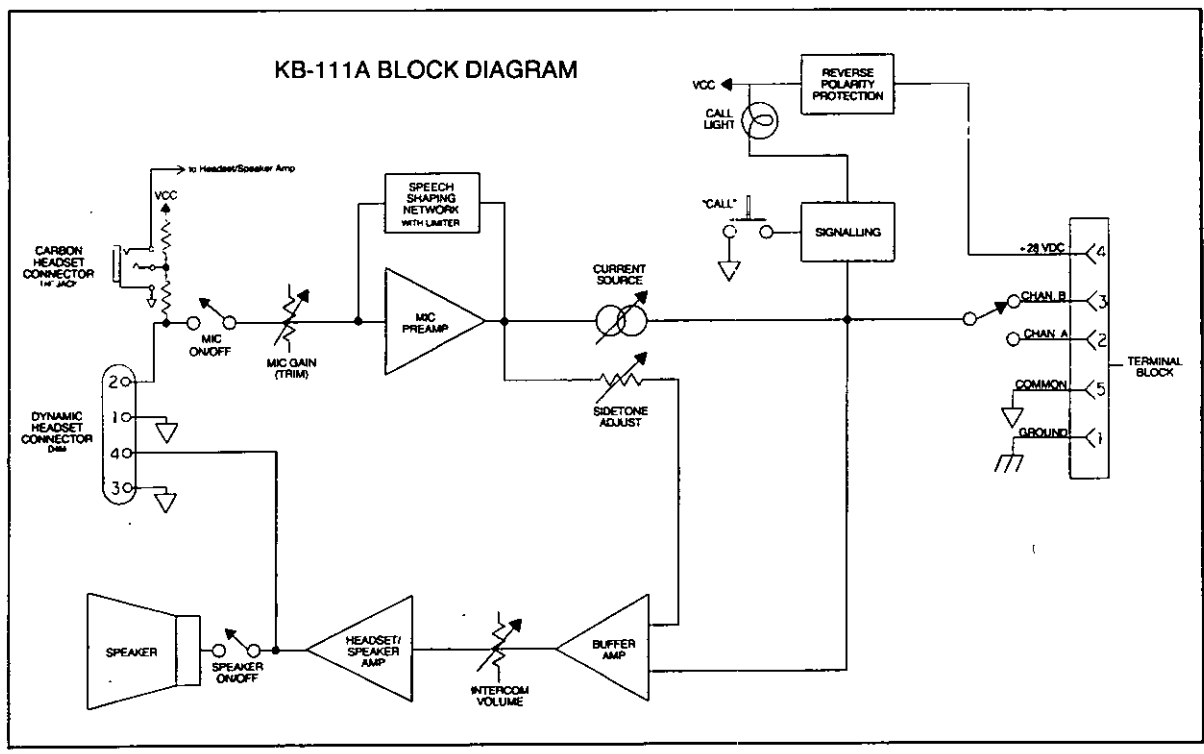
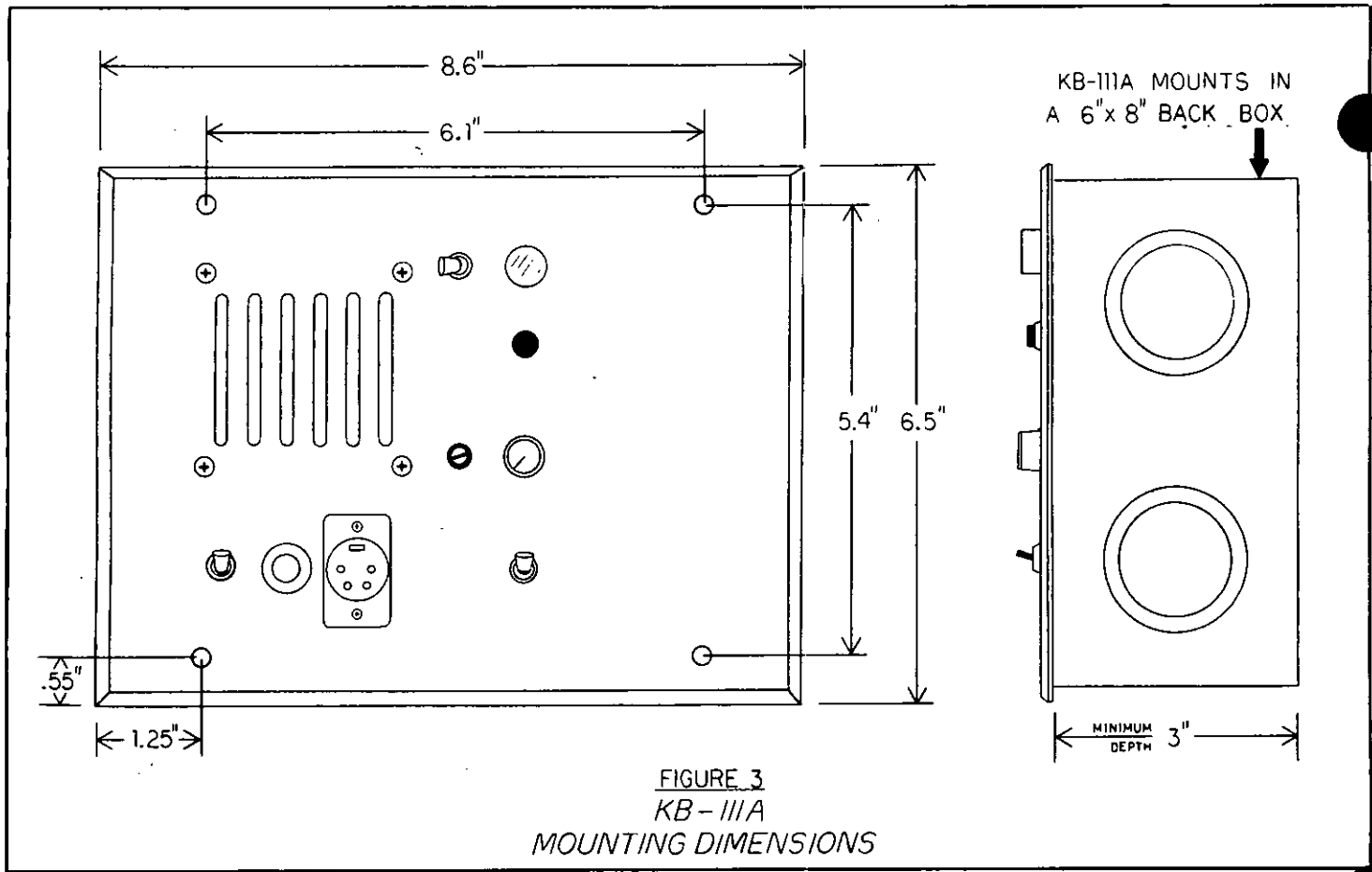

# KB-111A FIXED INSTALLATION WIRING (TWO-CHANNEL)

CONNECT TO EARTH GROUND IF  
NON-GROUNDED ENCLOSURE IS USED

2 2-CONDUCTOR SHIELDED PAIR

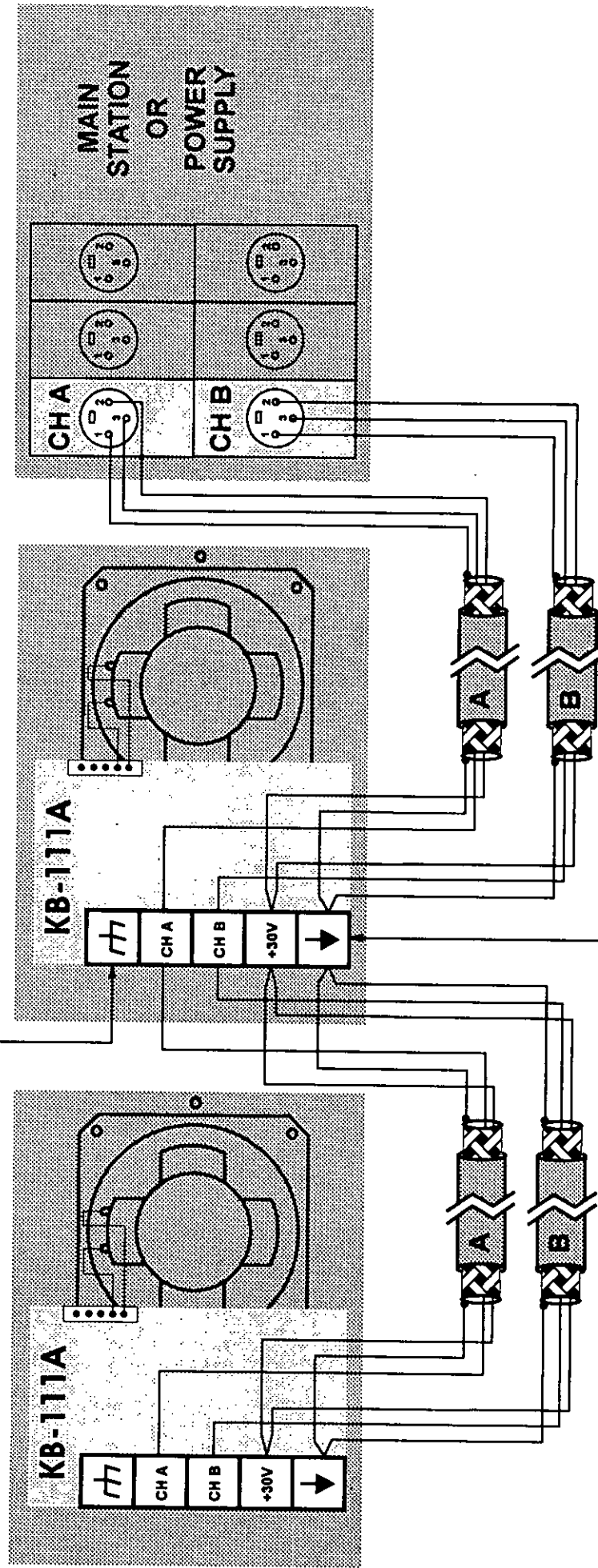

NOTE: IF WIRES DO NOT FIT IN STATION CONNECTOR BLOCK,  
USE SEPARATE TERMINAL STRIP OR JUNCTION BLOCK TO  
CONNECT WIRES TOGETHER



To install the KB-111A in a P-Box:

- 1) Remove the plastic screw terminal block from the header on the KB-111A PC Board; pull straight up to lift block off.
- 2) A similar terminal block is wired to the P-Box's 3-pin connectors; plug that block onto the KB-111A's 5-pin header. The terminal block and the PC Board are clearly labelled with the pin numbers to ensure proper connections. See Figure 5, Portable Unit Connection.
- 3) Because the P-Box accepts one channel, the KB-111A's "Channel Select" toggle switch is ineffective. No matter which position this switch is in, the KB-111A operator communicates on the one channel that's fed into the P-Box.
- 4) Attach the KB-111A to the front of the P-Box, using the supplied screws. If desired, attach the handle and the protective rubber feet onto the suitable sides. The enclosure also has cut-outs

on each side for hanging it from the wall, a console, or where ever.

Use standard two-conductor mic cable (i.e., Belden 8413) with 3-pin connectors to interconnect the portable station within the intercom system. The pin-out assignment for each XLR connector is:

Pin 1-- common  
Pin 2-- +30 volts DC  
Pin 3-- intercom audio

Route cable from the Main Station, Power Supply, or another Remote Station to the portable KB-111A, and input to the female connector. Use the male output connector to "daisy-chain" the intercom line between the KB-111A and another portable Remote Station.

A diode in the DC input of the KB-111A protects the circuitry against wiring in the interconnect cables. All Remote Stations bridge the terminated audio line with approximately 15k ohms.

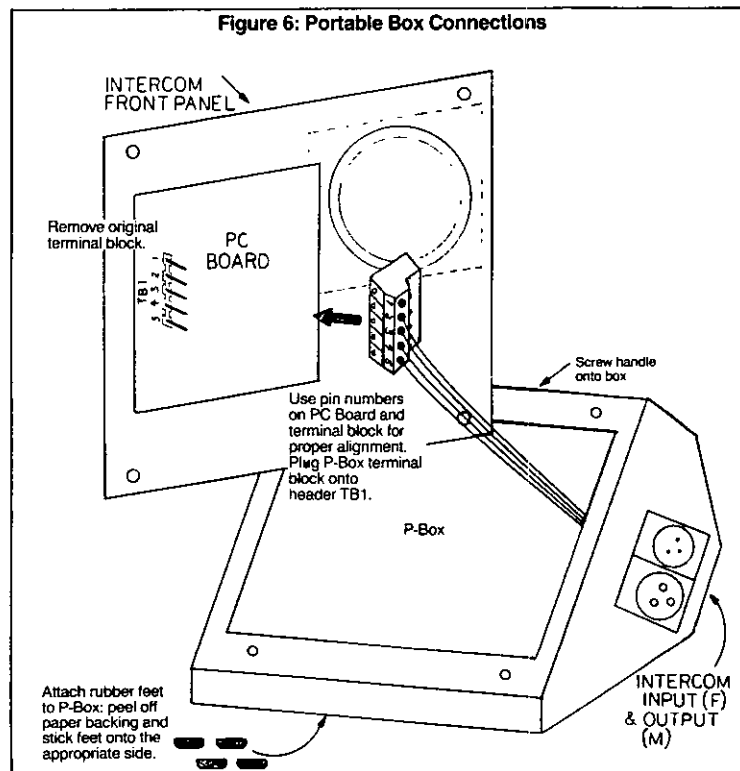

#### IV. KB-111A OPERATING CONTROLS

##### "A/B Chan. Select"

This toggle switch selects the channel on which the operator will communicate. (This switch is defeated when the KB-111A is mounted in a P-Box.)

##### "Volume"

This knob adjusts the listen-level for the speaker/headset.

##### "Speaker On/Off"

This toggle switch determines the activity of the speaker.

##### "Mic On/Off/(On)"

This three-position toggle switch determines the activity of the microphone in your headset, handset, or gooseneck. When the switch is set to the top "on" position, the mic remains on. When it's in the middle position, the mic is off. The bottom "(on)" position is a momentary setting.

##### "Sidetone Adj."

The sidetone control enables the KB-111A operator to adjust the level of his/her voice as heard in the Station's speaker or headset, allowing up to 35 dB reduction of acoustical pick-up. You need only adjust the sidetone once (if at all), even if other stations subsequently join or leave the intercom system. Adjusting the sidetone does not affect the level of incoming or outgoing signals.

The sidetone control is inside a hole next to the Volume knob. Use a small blade screwdriver for adjustment.

At the factory. Clear-Com sets the

sidetone to be approximately 6 dB lower than incoming signals. If you want to change this level, take these steps:

- 1) plug in headset
- 2) turn on mic
- 3) turn up volume all the way
- 4) insert screwdriver into hole and engage the slot on the trimpot inside
- 5) begin talking into mic while slowly turning screwdriver; the volume of your voice will rise or drop. When using both the headset and the speaker, set the sidetone for maximum null (you can't hear yourself).

##### "Call"

The black push-button activates the visual signal circuit that's standard on Clear-Com intercoms. It allows the intercom user to attract the attention of operators who have removed their headsets or turned off their speakers. Call signalling follows the position of the Channel Select switch; for instance, if you are using Channel A, pressing the Call button activates the signal circuitry at all stations that are assigned to Channel A. As long as you keep the button pressed, the Call circuit will stay active.

The Call button also activates the speaker and/or mic at any other Station (on the same channel) that is set up for remote control.

The amber Call Lamp illuminates when any Station, on the same channel, activates a Call signal.

If you need to receive a Call signal from the channel you're not using, refer to the special modification diagram on page 9.

V. KB-111A FRONT PANEL PARTS LISTING

Part #	Description	Qty.	Schematic Reference
210013	Connector, D4M	1	J2
210050	Connector, 1/4" phone jack	1	J1
240015	Knob, 1/2" with 1/8" shaft	1	P3
240020	Button cover, red (510028- switch, snap-action)	1	S1
250144	Panel, front, KB-111A	1	---
280067	Nut, dress cone	2	Call, Channel Select
280071	Nut, 1/4" dress	2	Speaker and Mic On/Off
390000	Lamp cover, amber (390001- bulb, #387)	1	I1
500089	Speaker, 3" round	1	SP1
510006	Switch, mini toggle	1	Speaker On/Off
510040	Switch, mini toggle	1	Channel Select
510044	Switch, 3-position	1	Mic On/Off/On

VI. KB-111A SPECIFICATIONS

AMPLIFIER DESIGN

Solid-state, integrated circuit amplifiers which include a mic preamp, headset/speaker power amp, and signalling circuitry. Current-limited with short circuit and reverse polarity protection.

MIC PREAMPLIFIER

Freq. Response: 250-12k Hz, with mic limiter; contoured to enhance intelligibility  
 Mic Input: 200 ohms  
 Mic Preamp Gain: 37 dB  
 Max Input Before Clipping: -20 dB  
 Mic Limiter Threshold: -37 dBm

HEADSET/SPEAKER AMPLIFIER

Freq. Response: 100-18k Hz, ± 2 dB  
 Load Impedance Range: 8-2000 ohms (dynamic headset)  
 Output Level: +20 dBm, 26v p-p @ 100 ohms  
 Headset Level: >110 dB SPL with standard Clear-Com headset  
 Speaker Level: >98 dB SPL @ 3 feet  
 Speaker Type: 3" round, 16 ohms  
 Power Output: 4 watts peak  
 Distortion: 0.5% THD @ 1kHz  
 Headphone Amp Gain: 40 dB

GENERAL SPECIFICATIONS

Line Level: -20 dB avg., 0 dB max.  
 Sidetone Adj.: 35dB null to full on  
 Signal Voltage: 11VDC on audio line  
 Call Light Sensitivity: 4 volts  
 Signal-to-Noise: 75 dB  
 Equivalent Input Noise: -118 dB  
 Station Bridging Impedance: >12k ohms (200-10k Hz)  
 Voltage Range: 12-32 volts, 28v nominal  
 Power Required: 25 ma quiescent, 60 ma talk, 60 ma signalling, 200 ma short circuit  
 Dimensions (front panel): 8.6" x 6.5" x 3.25" deep

CONNECTORS

Dynamic Headset: Male D4M  
 Carbon Headset: 1/4" phone jack  
 Line: 5-screw terminal block (portable unit: 1 Male D3M, 1 Female D3F)

## VII. Special Modification: Signalling Configuration in Multi-Channel Systems

In normal circumstances, the KB-111A Call Light illuminates when someone signals on the channel that the KB-111A operator has selected for communication. This is because the visual signal travels, in the form of DC voltage, on that channel's line.

You can alter this configuration by making the modification described below.

In our application (Figure 7), a group of two-channel stations

(i.e., KB-111A) have selected Channel B for communication. Yet they want to be capable of receiving a Call signal from stations that are communicating on Channel A.

This is achieved by putting four diodes (914 type) in series between the two channels on the interconnect cable. Call signalling is now possible from Channel A to Channel B. Since the Call signal follows the direction of the diodes, this is one-way signalling; Channel B cannot send a signal to Channel A.

FIGURE 7: ALTERNATIVE SIGNALLING

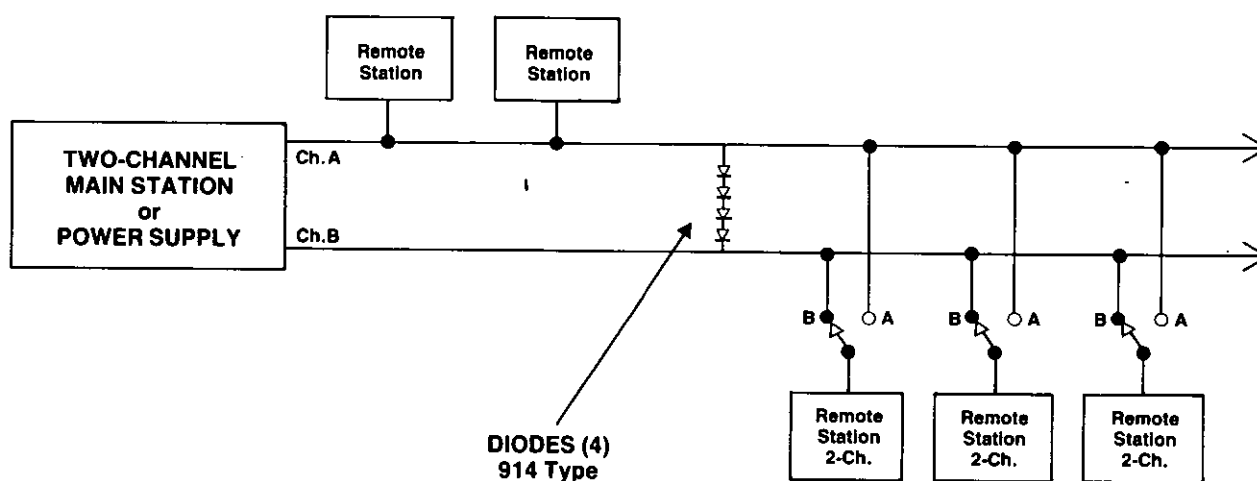
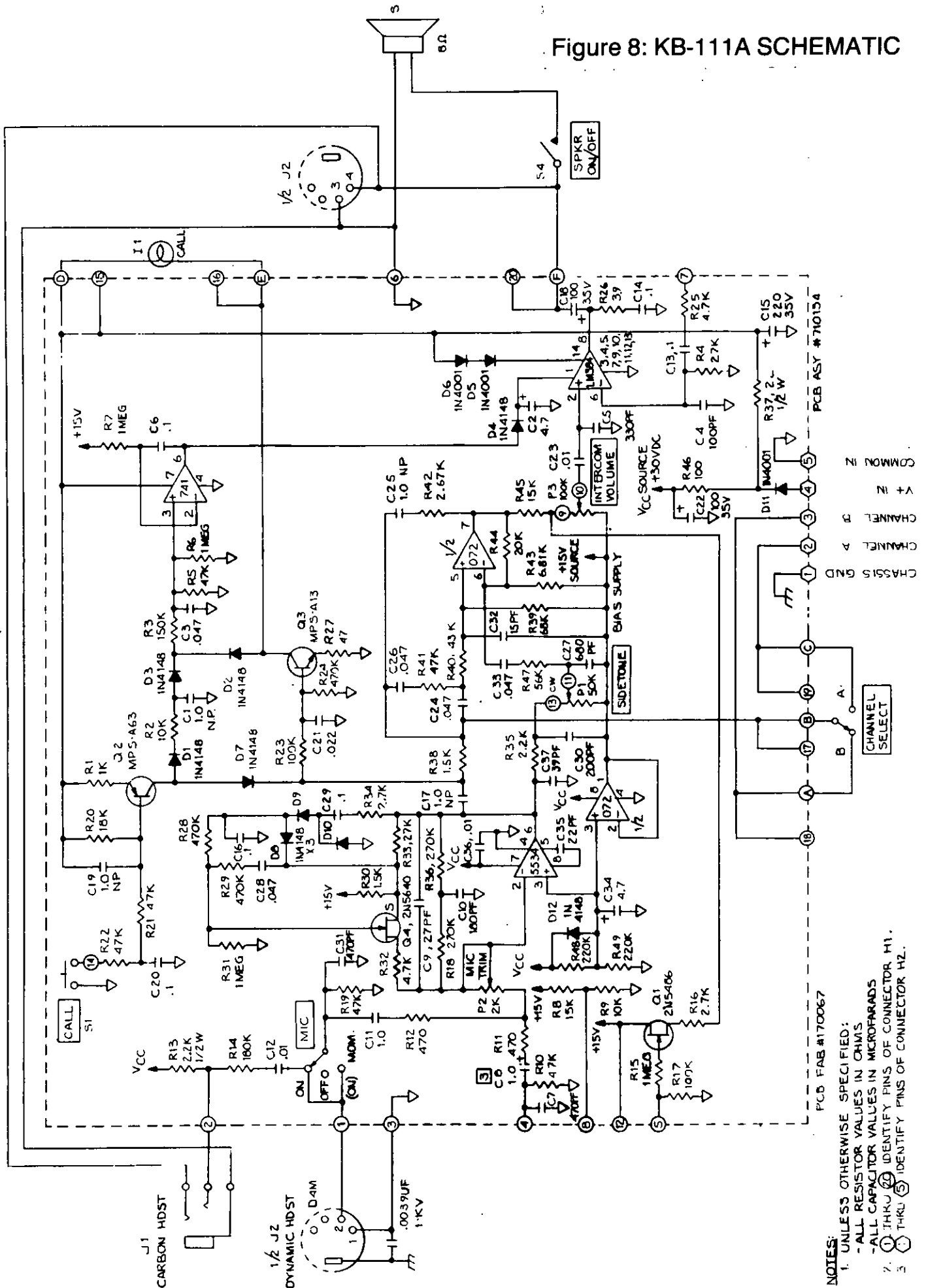

Figure 8: KB-111A SCHEMATIC



- NOTES:**
1. UNLESS OTHERWISE SPECIFIED:  
- ALL RESISTOR VALUES IN OHMS  
- ALL CAPACITOR VALUES IN MICROFARADS
  2. (1) THRU (23) IDENTIFY PINS OF CONNECTOR H1.
  3. (1) THRU (5) IDENTIFY PINS OF CONNECTOR H2.