



Yes, you can.®



Invacare® Mirage

**Power wheelchair
User manual**



How can you get in touch with Invacare®?

If you have any questions or need support, please contact your authorised Invacare® Dealer, who has the necessary know-how and equipment plus the special knowledge concerning your Invacare® product, and can offer you all-round satisfactory service. Should you wish to contact Invacare® directly, you can reach us in Europe at the following addresses and phone numbers.

A	Invacare Austria GmbH Herzog Odilostrasse 101 A-5310 Mondsee Austria	☎: Fax: @: WWW:	+43 6232 5 53 50 +43 6232 5 53 54 info@invacare-austria.com www.invacare.at
----------	--	--------------------------	--

B	Invacare n.v. Autobaan 22 B-8210 Loppem (Brugge)	☎: Fax: @: WWW:	+32 (0)50 83 10 10 +32 (0)50 83 10 11 belgium@invacare.com www.invacare.be
----------	---	--------------------------	---

CH	Invacare AG Benkenstraße 260 CH-4108 Witterswil Switzerland	☎: Fax: @: WWW:	+41 (0)61487 70 80 +41 (0)61487 70 81 switzerland@invacare.com www.invacare.ch
-----------	---	--------------------------	---

D	Invacare GmbH Alemannenstraße 10 88316 Isny Deutschland	☎: Fax: @: WWW:	+49 (0)7562 70 00 +49 (0)7562 7 00 66 kontakt@invacare.com www.invacare.de
----------	---	--------------------------	---

DK	Invacare A/S Sdr. Ringvej 37 DK-2605 Brøndby Danmark	☎ (Kundeservice): Fax (Kundeservice): @: WWW:	+45 (0)36 90 00 00 +45 (0)36 90 00 01 denmark@invacare.com www.invacare.dk
-----------	--	--	---

E	Invacare® SA c/ Areny s/n Polígon Industrial de Celrà E-17460 Celrà (Girona) ESPAÑA	☎: Fax: @: WWW:	+34 (0)972 49 32 00 +34 (0)972 49 32 20 contactsp@invacare.com www.invacare.es
----------	--	--------------------------	---

F	Invacare® Poirier SAS Route de St Roch F-37230 Fondettes France	☎: Fax: @: WWW:	+33 (0)247 62 64 66 +33 (0)247 42 12 24 contactfr@invacare.com www.invacare.fr
GB	Invacare® Ltd Pencoed Technology Park Pencoed Bridgend CF35 5AQ United Kingdom	☎ (Customer services): Fax (Customer services): @: WWW:	+44 (0)1656 77 62 22 +44 (0)1656 77 62 20 uk@invacare.com www.invacare.co.uk
I	Invacare Mecc San s.r.l. Via dei Pini, 62 I - 36016 Thiene (VI) ITALIA	☎: Fax: @: WWW:	+39 0445 38 00 59 +39 0445 38 00 34 italia@invacare.com www.invacare.it
IE	Invacare Ireland Ltd. Unit 5 Seatown Business Campus Seatown Rd, Swords County Dublin Ireland	☎: Fax: @: WWW:	+353 18 10 70 84 +353 18 10 70 85 ireland@invacare.com www.invacare.ie
N	Invacare® AS Grensesvingen 9 Postboks 6230 Etterstad N-0603 Oslo Norge	☎ (Kundeservice): Fax (Kundeservice): @: @: WWW:	+47 (0)22 57 95 00 +47 (0)22 57 95 01 norway@invacare.com island@invacare.com www.invacare.no
NL	Invacare® B.V. Celsiusstraat 46 NL-6716 BZ Ede Nederland	☎: Fax: @: @: WWW:	+31 (0)318 69 57 57 +31 (0)318 69 57 58 nederland@invacare.com csede@invacare.com www.invacare.nl
P	Invacare Lda Rua Estrada Velha, 949 P-4465-784 Leça do Balio Portugal	☎: ☎: Fax: @: WWW:	+351 225 10 59 46 +351 225 10 59 47 +351 225 10 57 39 portugal@invacare.com www.invacare.pt



Aterförsäljare:
Invacare® AB
Fagerstagatan 9
S-163 91 Spånga
Sverige

☎ (Kundtjänst): +46 (0)8 761 70 90
Fax (Kundtjänst): +46 (0)8 761 81 08
@: sweden@invacare.com
@: finland@invacare.com
WWW: www.invacare.se



Tillverkare:
Invacare® Deutschland GmbH
Kleiststraße 49
D-32457 Porta Westfalica
Deutschland

MÖLNDAL
☎: +46 (0)31 86 36 00
Fax: +46 (0)31 86 36 06
@: ginvacare@invacare.com

LANDSKRONA
☎: +46 (0)418 2 85 40
Fax: +46 (0)418 1 80 89
@: linvacare@invacare.com

OSKARSHAMN
☎: +46 (0)491 1 01 40
Fax: +46 (0)491 1 01 80
@: oinvacare@invacare.com

**Eastern
european
countries**

**European Distributor
Organisation (EDO)**
Kleiststraße 49
D-32457 Porta Westfalica
Deutschland

☎: +49 (0)5731 75 45 40
Fax: +49 (0)5731 75 45 41
@: edo@invacare.com
WWW: www.invacare.de

Table of Contents

Chapter		Page
1	Introduction	10
1.1	Important symbols in this manual	11
1.2	Important symbols found on the vehicle	13
1.3	Type classification and permissible use.....	15
1.4	Indications.....	16
1.5	Usability.....	16
1.6	Warranty	17
1.7	Life expectancy.....	18
2	Safety notes	19
2.1	General safety notes	19
2.2	Safety information with regard to care and maintenance	22
2.3	Safety information on electromagnetic interference	23
2.4	Safety information on driving and freewheel mode.....	24
2.5	Safety information on maintenance work and alterations to the wheelchair.....	27
3	Key features	30
4	Getting in and out of the wheelchair	31
4.1	Using the cane holder	31
4.2	Remove the standard armrest in order to side transfer	32
4.3	Swinging the kerb climber rearward to get in and out of the powerchair	33
5	Driving	35
5.1	Before driving for the first time.....	35

5.2	Taking Obstacles	36
5.2.1	Maximum obstacle height	36
5.2.2	Safety information when ascending obstacles	36
5.2.3	The correct way to overcome obstacles	37
5.3	Driving up and down gradients	38
5.4	Parking and stationary	39
5.4.1	Activating and deactivating the manual wheel lock	39
5.5	Use on public roads	40
6	Pushing the wheelchair in freewheel mode	40
6.1	Disengaging Motors	40
7	Remotes	41
8	Adjusting the wheelchair to the user's seating posture	42
8.1	Adjusting the armrests and the control panel	42
8.1.1	Adapting the control panel to the length of the user's arm	42
8.1.2	Setting the height of the remote	43
8.1.3	Setting the height of the armrests	44
8.1.4	Adjusting the width of the armrests	45
8.2	Adjusting the backrest	48
8.2.1	Gas spring angle adjustment	48
8.2.2	Manual angle adjustment	49
8.2.3	Adjusting the tension adjustable backrest upholstery	50
8.3	Folding the backrest over	51
8.4	Postural belts	53
8.4.1	Types of postural belts	53
8.4.2	Adjusting the postural belt correctly	54
8.5	Headrest	55
8.6	Adjusting and removing the tray	56
8.6.1	Laterally adjusting the tray	56

8.6.2	Adjusting the depth of the tray / removing the tray	57
8.6.3	Swinging the tray away to the side	57

9 Adjusting footrests and legrests 59

9.1	Standard legrests	59
9.1.1	Swivelling the footrest outward and/or removing	59
9.1.1.1	Adjusting the length	61
9.2	Manually height-adjustable legrest	62
9.2.1	Swivelling the footrest outward and/or removing	62
9.2.2	Adjusting the angle	63
9.2.3	Adjusting legrest length	64
9.2.4	Adjusting the calf support depth	65
9.2.5	Adjusting the calf support height	66
9.2.6	Adjusting the angle and depth adjustable foot plate	67

10 Electrical system 68

10.1	Electronics protection system	68
10.1.1	The main circuit breakers	69
10.2	Batteries	70
10.2.1	Charging the batteries	70
10.2.1.1	General information on charging	70
10.2.1.2	General instructions on charging	70
10.2.1.3	How to charge the batteries	71
10.2.1.4	How to disconnect the batteries after charging	72
10.2.2	Storage and Maintenance	73
10.2.3	Instructions on using the batteries	73
10.2.4	Transporting batteries	75
10.2.5	Handling batteries	75
10.2.5.1	General instructions on handling the batteries	75
10.2.5.2	How to handle damaged batteries correctly	75
10.2.5.3	Removing the batteries	77

11	Care and maintenance	81
12	Maintenance- and repair work	84
12.1	Repairing a flat tyre	84
12.1.1	Repairing a flat tyre at the back (tyre type 3.00-8")	85
13	Transport	88
13.1	Transferring the wheelchair to a vehicle.....	89
13.2	Securing the wheelchair for transport without passengers	90
13.3	Use of the wheelchair as a seat in a vehicle.....	91
13.3.1	How the wheelchair is anchored in a vehicle for use as a vehicle seat	93
13.3.2	How the user is secured within the wheelchair.....	95
13.4	Dismantling the wheelchair for transport	99
13.4.1	Removing legrests	100
13.4.2	Removing the kerb climber	100
13.4.3	Removing batteries.....	102
13.4.4	Removing backrest frame cross strut	104
13.4.5	Folding the wheelchair.....	105
13.4.6	Reassembling the wheelchair.....	107
14	Refurbishment	107
15	Disposal	108
16	Technical specifications	109
17	Inspections Performed	113

1 Introduction

Dear user,

First we would like to thank you for purchasing our product! We hope that you will have a great deal of pleasure with your new power wheelchair.

This operating manual contains important information and notes about:

- **Safety**
- **Operation**
- **Care and maintenance**

Please take care to read the operating manual thoroughly before starting out on your first journey.

This wheelchair has been constructed for a large circle of users with different requirements.

The decision whether the model is suitable for the user may only be taken by medical specialists with appropriate expertise.

Invacare® or their statutory representatives can accept no liability in cases in which the wheelchair has not been adapted to suit the users' handicaps.

Some maintenance and settings can be performed by the user or his/hers attendants. Certain adjustments do however require technical training and may only be carried out by your Invacare® specialist dealer. Damages and errors caused by nonobservance of the user manual or as a result of incorrect maintenance are excluded from all guarantees.

This manual contains copyrighted information. This manual may not be reproduced or reprinted either partly or completely without previous written consent from Invacare® or its statutory representatives. We reserve the right to make any necessary alterations on the grounds of technical improvements.

1.1 Important symbols in this manual



General risks

This symbol warns you of general hazards!

- *Always follow the instructions to avoid injury to the user or damage to the product.*
-



EXPLOSION HAZARD!

This symbol warns you of an explosion hazard, which can be caused by excessive tyre pressure in a pneumatic tyre.

- *Always follow the instructions to avoid injury to the user or damage to the product.*
-



BURN HAZARD!

This symbol warns you of the danger of chemical burns, for example due to the discharge of battery acids!

- *Always follow the instructions to avoid injury to the user or damage to the product.*
-



BURN Risk!

This symbol warns of the risk of burns, for example, as a result of hot motor surfaces.

- *Follow the instructions in order to avoid injury or damage to the product.*
-



RISK OF CRUSHING!

This symbol warns of a risk of crushing caused by being careless with heavy components.

- *Always follow the instructions to avoid injury to the user or damage to the product.*
-



Wear eye protection

This symbol refers to the requirement for wearing eye protection, for example when working with batteries.

- *You must wear safety goggles when this symbol is displayed.*
-



Wear protective gloves

This symbol indicates the requirement to wear protective gloves, for example when working with batteries.

You must wear protective gloves when this symbol is displayed.



NOTE:

This symbol identifies general information which is intended to simplify working with your product and which refers to special functions.



Requirements:

- This symbol identifies a list of various tools, components and items which you will need in order to carry out certain work. Please do not attempt to carry out the work if you do not have the listed tools available.
-



READ WELL BEFORE OPERATION!

This symbol advises you to read information carefully.

1.2 Important symbols found on the vehicle



This product has been supplied from an environmentally aware manufacturer. This product may contain substances that could be harmful to the environment if disposed of in places (landfills) that are not appropriate according to legislation.

- *The 'crossed out wheelie bin' symbol is placed on this product to encourage you to recycle wherever possible.*
 - *Please be environmentally responsible and recycle this product through your recycling facility at its end of life.*
-



This symbol indicates the “Drive” position of the coupling lever. In this position the motor is engaged and the motor brakes are operational. You can drive the wheelchair.

- *Please note that for driving purposes both motors must always be engaged.*



This symbol indicates the “Push” position of the coupling lever. In this position the motor is disengaged and the motor brakes are not operational. The wheelchair can be pushed by an attendant and the wheels turn freely.

- *Please note that the control panel must be switched off.*
 - *Please also note the information provided in section "**Pushing the wheelchair in freewheel mode**" on page 40.*
-



This symbol indicates the position of an anchor point when using a lashing system during transport.



If the symbol appears on a bright yellow sticker, the anchoring point is suitable for fixation of the wheelchair in a vehicle for use as a vehicle seat.



This wheelchair may not be used as a vehicle seat!

- *This wheelchair does not satisfy the requirements of ISO 7176-19:2001 and may not under any circumstances be used as a vehicle seat or to transport the user in a vehicle.*
 - *Using a wheelchair that does not fulfill these criteria as a vehicle seat can lead to the most severe injuries and even death in the event of a traffic accident.*
-

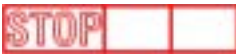

This symbol indicates the maximum width to which an armrest may be adjusted. Pulling the armrest out further can cause it to fall out of its fixation. For further information, see chapter "Adjusting the width of the armrests" on page 45.



If the power wheelchair is fitted with a table, it is imperative that it is removed and safely stowed when transporting the wheelchair in a vehicle!

1.3 Type classification and permissible use

This vehicle was designed for persons whose ability to walk is impaired, but who are still in terms of their eyesight and physically and mentally able to operate an electric vehicle. It has been classified according to EN 12184 as a **class B mobility product** (for indoor and outdoor areas). It is therefore compact and agile enough for indoor areas, but also able to overcome many obstacles in outdoor areas.

You can find precise information about speed, turning radius, driving range, maximum safe slope, maximum obstacle height and permissible operating conditions in chapter "Technical specifications" starting from page 109.

Please also pay attention to all safety information in chapter "Safety notes" starting from page 19.

The vehicle was successfully tested according to German and international standards as to its safety. It satisfies the requirements according to DIN EN 12184 including EN 1021-1/-2. It was also tested successfully according to EN60529 IPX4 as to its resistance to spray water, and is therefore well suited for typical middle European weather conditions. When equipped with an appropriate lighting system, the vehicle is suitable for use on public roads.

1.4 Indications

The use of this mobility product is recommended for the following indications:

The inability or a greatly restricted ability to walk within the scope of the basic requirement to be able to move within one's own four walls. The need to leave the dwelling place in order to get some fresh air during a short walk or to reach those places generally to be found at close distance to the dwelling and where everyday business is carried out.

Provision of power wheelchairs for interior and exterior areas is advisable if the use of hand-operated wheelchairs is no longer possible on account of the disability, yet proper operation of an electromotive drive unit is still practicable.

1.5 Usability

Only use a power wheelchair when it is in perfect working order. Otherwise, you might put yourself and others at risk.

The following list does not claim to be exhaustive. It is only intended to show some of the situations that could affect the usability of your power wheelchair.

In certain situations, you should immediately stop using your wheelchair. Other situations allow you to use the wheelchair to get to your dealer.

- You should immediately stop using your power wheelchair if its usability is restricted due to:
 - brake failure
- You should immediately contact an authorised Invacare® dealer if the usability of your power wheelchair is restricted due to:
 - the lighting system failing or being defective

- reflectors falling off
- worn thread or insufficient tyre pressure
- damage to the armrests (e.g. torn armrest padding)
- damage to the legrest hangers (e.g. missing or torn heel loops)
- damage to the postural belt
- damage to the joystick (joystick cannot be moved into the neutral position)
- cables that are damaged, kinked, pinched or have come loose from the holder
- the wheelchair drifting when braking
- the wheelchair pulling to one side when moving
- unusual sounds developing or occurring

Or if you have the feeling that something is wrong with your wheelchair.

1.6 Warranty

The terms and conditions of the warranty are part of the general terms and conditions particular to the individual countries in which this product is sold.

1.7 Life expectancy

We estimate a life expectancy of five years for this product, provided it is used in strict accordance with the intended use as set out in this document and all maintenance and service requirements are met. The estimated life expectancy can be exceeded if the product is carefully used and properly maintained, and provided technical and scientific advances do not result in technical limitations. The life expectancy can also be considerably reduced by extreme or incorrect usage. The fact that we estimate a life expectancy for this product does not constitute an additional warranty.

2 Safety notes



READ WELL BEFORE OPERATION!

2.1 General safety notes



Danger of injury if mobility device is used in any other way than the purpose described in this manual!

- *Only ever use the mobility device in accordance with the instructions in this User's Manual (see chapter "Type classification and permissible use" on page 15).*
- *Pay strict attention to the safety information.*

Danger of injury if the mobility device is driven when ability to operate a vehicle is impaired by medication or alcohol!

- *Never drive the mobility device under the influence of medication or alcohol. If necessary, the mobility device must be operated by an attendant who is physically and mentally able.*

Danger of damage or injury if mobility device is accidentally set into motion!

- *Switch the mobility device off before you get in, get out or handle unwieldy objects.*
 - *When the drive is disengaged, the brake inside the drive is deactivated. For this reason, pushing the mobility device by an attendant is only recommended on flat surfaces, never on gradients. Never leave your mobility device on a gradient with its motors disengaged. Always re-engage the motors immediately after pushing the mobility device (see chapter "Pushing the wheelchair in freewheel mode" on page 40).*
-



Danger of injury if the mobility device is switched off while driving, for example by pressing the On/Off Button or disconnecting a cable, due to it coming to an abrupt, sharp stop!

- *If you have to brake in an emergency, simply release the joystick which will bring you to a halt. (refer to the joystick operating manual for more information).*

Danger of injury when transferring mobility device to a vehicle for transport with the occupant seated in it!

- *It is always better to transfer the mobility device to a vehicle without the occupant seated in it.*
- *If the mobility device needs to be loaded up a ramp together with its driver, ensure that the ramp does not exceed the maximum safe slope (see chapter "Technical specifications" from page 109).*
- *If the mobility device does need to be loaded using a ramp which exceeds the maximum safe slope (see chapter "Technical specifications" from page 109), then you must use a winch. An attendant can safely monitor and assist the loading process.*
- *As an alternative you can use a platform lift. Ensure that the total weight of the mobility device including the user does not exceed the maximum permissible weight for the platform lift or winch if you are using.*

Danger of injury if maximum permissible load is exceeded!

- *Do not exceed the maximum permissible load (see chapter "Technical specifications" from page 109).*
 - *The mobility device is only designed for use by a single occupant whose maximum weight does not exceed the maximum permissible load of the device. Never use the mobility device to transport more than one person.*
-



Danger of injury due to wrong lifting or dropping of heavy components!

- *When maintaining, servicing or lifting any part of your mobility device, take into account the weight of the individual components especially the batteries. Be sure at all times to adopt the correct lifting posture and ask for assistance if necessary.*

Danger of falling out of the mobility device.

- *Do not slide forward on the seat, do not lean forward between your knees, do not lean backwards out over the top of the backrest, for example to reach an object.*
- *If a posture belt is installed, it should be correctly adjusted and used each time you use the mobility device.*
- *When transferring to a different seat, position the mobility device as close as possible to the new seat.*

Danger of injury by moving parts!

- *Make sure that no injury is incurred by moving parts of the mobility device, like wheels or one of the Lifter Modules (if fitted), especially when children are around.*

Risk of injury from hot surfaces!

- *Do not leave the wheelchair in direct sunlight for prolonged periods. Metal parts and surfaces such as the seat and armrests can become very hot.*

Danger of fire or breaking down due to electric devices being connected!

- *Do not connect any electric devices to your mobility device that are not expressly certified by Invacare® for this purpose. Have all electrical installations done by your authorised Invacare® Dealer.*
-



Danger of injury and damage to wheelchair if the cross strut that connects the push handles becomes loosened during use, or is removed intentionally!

- *The cross strut between the push handles stabilizes the folding backrest and must be securely fitted at all times during use! It may only be removed to disassemble and/or fold the wheelchair!*
-

2.2 Safety information with regard to care and maintenance



Danger of accident and loss of guarantee if maintenance is insufficient!

- *For reasons of safety and in order to avoid accidents which result from unnoticed wear, it is important that this electric mobility product undergoes an inspection once every year under normal operating conditions (see inspection plan contained in service instructions).*
 - *Under difficult operating conditions such as daily travel on steep slopes, or in the case of use in medical care cases with frequently changing wheelchair users, it would be expedient to carry out intermediate checks on the brakes, accessories and running gear.*
 - *If the mobility product is to be operated on public roads, the vehicle driver is responsible for ensuring that it is in an operationally reliable condition. Inadequate or neglected care and maintenance of the mobility product will result in a limitation of the manufacturer's liability.*
-

2.3 Safety information on electromagnetic interference

This electric vehicle was successfully tested in accordance with International standards as to its compliance with Electromagnetic Interference (EMI) regulations. However, electromagnetic fields, such as those generated by radio and television transmitters, and cellular phones can influence the functions of electric vehicles. Also, the electronics used in our vehicles can generate a low level of electromagnetic interference, which however will remain within the tolerance permitted by law. For these reasons we ask you to please observe the following precautions:



WARNING: Danger of malfunction due to electromagnetic interference!

- *Do not switch on or operate portable transceivers or communication devices (such as radio transceivers or cellular phones) when the vehicle is switched on.*
 - *Avoid getting near strong radio and television transmitters.*
 - *In case the vehicle should be set in motion unintentionally or the brakes are released, switch it off immediately.*
 - *Adding electrical accessories and other components or modifying the vehicle in any way can make it susceptible to electromagnetic interference. Keep in mind that there is no sure way to determine the effect such modifications will have on the overall immunity of the electronic system.*
 - *Report all occurrences of unintentional movement of the vehicle, or release of the electric brakes to the manufacturer.*
-

2.4 Safety information on driving and freewheel mode



Danger of injury if the wheelchair tips over!

- *Inclines and declines can only be travelled up to the maximum safe slope (see chapter "Technical specifications" from page 109).*
 - *Always return the backrest of your seat or the seat tilt to an upright position before ascending slopes. We recommend that you position the seat backrest and the seat tilt (if fitted) slightly to the rear before descending slopes.*
 - *Only ever drive downhill at a maximum of 2/3 of the top speed. Avoid abrupt braking or accelerating on gradients.*
 - *If at all possible, avoid driving on slippery surfaces (such as snow, gravel, ice etc.) where there is a danger of you losing control over the vehicle, especially on a gradient. If driving on such a surface is inevitable, then always drive slowly and with the utmost caution.*
 - *Never attempt to overcome an obstacle when on an uphill or downhill gradient.*
 - *Never attempt to drive up or down a flight of steps with your wheelchair.*
 - *When overcoming obstacles, always observe the maximum obstacle height (see chapter "Technical specifications" from page 109 and information about overcoming obstacles in chapter "Taking Obstacles" from page 36).*
 - *Avoid shifting your centre of gravity as well as abrupt joystick movements and changes of direction when the wheelchair is in motion.*
 - *Never use the wheelchair to transport more than one person.*
 - *Do not exceed the overall maximum permissible load or the maximum load per axle (see chapter "Technical specifications" on page 109).*
 - *Note that the wheelchair will brake or accelerate if you change the Driving Mode whilst the wheelchair is in motion.*
-



Danger of breaking down in adverse weather conditions, i.e. extreme cold, in an isolated area!

- *If you are a user with severely limited mobility, we advise that in the case of adverse weather conditions DO NOT attempt a journey without an accompanying attendant!*

Danger of injury if your foot slides off the footrest and gets caught underneath the wheelchair when it is in motion!

- *Make sure each time before you drive the wheelchair that your feet are squarely and securely in place on the footplates, and that both legrests are properly locked into place.*

Danger of injury if you collide with an obstacle when driving through narrow passages such as doorways and entrances!

- *Drive through narrow passages in the lowest driving mode and with due caution.*

If your power wheelchair has been fitted with angle-adjustable legrests, there is a danger of personal injury and damage to the wheelchair if you drive the wheelchair with the legrests raised!

- *To avoid unwanted displacement of the wheelchair centre of gravity to the front (especially when travelling downhill) and in order to avoid damage to the wheelchair, angle-adjustable legrests must always be lowered during normal travelling.*
-



CAUTION: Danger of tipping over if anti-tip wheels (1) are removed, damaged or adjusted to any position other than the factory setting!

- *Anti-tip wheels may only ever be removed for disassembling the wheelchair for transport in a vehicle, or for storage!*
- *During use of the wheelchair, the anti-tip wheels must be fitted at all times!*





CAUTION: Danger of tipping! Anti tip wheels (stabilisers) are only effective on firm ground! They sink in on soft ground such as grass, snow or mud if the mobility device rests itself on them. They lose their effect and the mobility device can tip over.

- *Only drive with extreme care on soft ground, especially during uphill and downhill journeys. In the process pay increased attention to the tip stability of the mobility device.*



CAUTION: Risk of injury from the backrest folding over during use!

If the folding backrest has not engaged properly, it may fold backwards unexpectedly when load is placed on it and you may fall from the wheelchair.

- *Before using the wheelchair, make sure that the backrest is folded up and the hinges have engaged.*
-

2.5 Safety information on maintenance work and alterations to the wheelchair



CE marking of the wheelchair

The conformity assessment/ CE marking was carried out in accordance with Directive 93/42 EEC / MPG (Medical Devices Act) and only applies to the complete product.

The CE marking is invalidated if components or accessories are replaced or added that have not been approved for this product by Invacare.

In this case, the company that adds or replaces the components or accessories is responsible for the conformity assessment/ CE marking or for registering the wheelchair as a special design and for the relevant documentation.



CAUTION: Danger of injuries and damage to mobility aid due to unapproved components and accessory parts!

Seating systems, additions and accessory parts which have not been approved by Invacare® for use with this mobility aid can affect the tipping stability and increase tipping hazards!

- *Only ever use seating systems, additions and accessory parts which have been approved by Invacare® for this mobility aid!*

Seating systems which are not approved by Invacare® for use with this power wheelchair do not, under certain circumstances, comply with the valid standards and could increase the flammability and the risk of skin irritation.

- *Only use seating systems that have been approved by Invacare® for this power wheelchair.*

Electrical and electronic components which have not been approved by Invacare® for use with this mobility aid can cause fire hazards and lead to electromagnetic damage!

- *Only ever use electrical and electronic components which have been approved by Invacare® for this mobility aid!*

Batteries which have not been approved by Invacare® for use with this mobility aid can cause chemical burns!

- *Only ever use batteries which have been approved by Invacare® for this mobility aid!*
-



CAUTION: Risk of injuries, and damage to the wheelchair, if unapproved backrests are used!

A retrofitted backrest which is not approved by Invacare® for use with this power wheelchair may overload the backrest tube and thus increase the risk of injuries and of damage to the wheelchair.

- *Please contact your Invacare® specialist dealer who will perform risk analyses, calculations, stability checks etc. to ensure that the backrest can be used safely.*
-



Important information about maintenance work tools!

Some maintenance work which is described in this manual and can be carried out by the user without problems require the correct tools for proper work. If you do not have the correct tool available we do not recommend that you try to carry out the relevant work. In this case, we urgently recommend that you contact an authorised specialist workshop.

3 Key features

- 1) Push handle cross-strut
- 2) Locking screw for adjusting armrest height
- 3) Locking screw for adjusting backrest angle
- 4) Manual wheel lock (only right side visible in the picture)
- 5) Disengaging lever (not visible in the picture, located on both sides on each motor)
- 6) Remote
- 7) Legrest unlocking lever



4 Getting in and out of the wheelchair



Important information when side transferring in and out of the wheelchair

In order to side transfer it is necessary for the armrest to either be raised or removed completely depending on the model. A skirtguard can be installed as an option in connection with the parallel sliding armrest. This is attached in the same way as the standard armrest and must also be removed when transferring.

4.1 Using the cane holder

If your mobility device is fitted with a cane holder, it can be used for the safe transport of a walking cane, underarm or forearm crutches. The cane holder consists of a plastic container (bottom) and a Velcro fastener (top).



WARNING! Risk of injury! A walking cane or crutches that are not secured during transport (on the user's lap, for example) can cause injury to the user or other persons!

- *During transport, walking canes or crutches should always be secured using a cane holder!*
-
- Open the upper Velcro fastener.
 - Place the lower end of the walking cane or the crutches in the container at the bottom.
 - The walking cane or the crutches can be secured at the upper end using the Velcro fastener.

4.2 Remove the standard armrest in order to side transfer

Removing the armrest:

- Loosen star key screw (1)
- Remove the side panel from the receptacle



4.3 Swinging the kerb climber rearward to get in and out of the powerchair

- Pull the handle (1) all the way forward. The kerb climber swings away towards the back and locks in place in this position.
- To bring the kerb climber back towards the front, push the handle (1) rearward.



Getting into the wheelchair:

- Position your wheelchair as close as possible to your seat. This might have to be done by an attendant.
- Switch your wheelchair off.
- Apply the manual wheel lock of your wheelchair (if existing).
- Detach the skirt guard of your wheelchair or swivel it up.
- Now slide into the wheelchair.



Getting out of the wheelchair:

- Drive your wheelchair as close as possible to your seat.
- Switch your wheelchair off.
- Apply the manual wheel lock of your wheelchair (if existing).
- Detach the skirt guard of your wheelchair or swivel it up.
- Now slide onto your new seat.



NOTE:

If you do not have sufficient muscle strength, you should ask other persons for help. Use a sliding board, if possible.

5 Driving



NOTE

The maximum load capacity that is stated in the technical data only states that the system is designed for this mass in total. However, this does not mean that one can sit a person with this body weight in the wheelchair without restrictions. Attention must be paid to the body proportions, such as height, weight distribution, abdominal girth, leg and calf girth and seat depth. These factors have a strong influence on driving features such as tilt stability and traction. The permissible axle loads in particular must be adhered to (see chapter "**Technical specifications**" as from page 109)! It may possibly be necessary to carry out adaptations to the seat system.

5.1 Before driving for the first time...

Before you take your first trip, you should familiarise yourself well with the operation of the vehicle and with all operating elements. Take your time to test all functions and driving modes.



NOTE:

If installed, make sure to properly adjust and use the postural belt each time you use the wheelchair.

Sitting Comfortably = Driving Safely

Before each trip, make sure that:

- You are within easy reach of all operating controls.
- The battery charge is sufficient for the distance intended to be covered.
- The postural belt (if installed) is in perfect order.

- The rear mirror (if installed) is adjusted so you can look behind at all times without having to bend forward or shift your seating position.

5.2 Taking Obstacles

5.2.1 Maximum obstacle height

You can find information about maximum obstacle heights in the chapter entitled "**Technical specifications**" from page **109**.

5.2.2 Safety information when ascending obstacles



CAUTION: Danger of Tipping Over!

- *Never approach obstacles at an angle but at 90 degrees as shown below.*
 - *Put your backrest into an upright position before climbing an obstacle.*
-



ATTENTION: Risk of falling out of the chair and damage to the power wheelchair such as broken castors!

- *Never approach obstacles that are higher than the maximum climbable obstacle height. For the maximum climbable obstacle height, see "Technical specifications" on page **109**.*
 - *If unsure whether the kerb climb is possible or not, move away from the obstacle and if possible find another location.*
-

5.2.3 The correct way to overcome obstacles



Information about the kerb climber!

A kerb climber is a mechanism which enables the electric wheelchair to overcome obstacles which would normally not be possible due to their height.

The way in which an obstacle should be approached (at right angles and slowly) is the same whether your wheelchair is fitted with a kerb climber or not.

Ascending

- Approach the obstacle or the kerb slowly, head-on and at a right angle.
- Depending on the wheel drive type, stop in one of the following positions:
 - In the case of centrally driven wheelchairs: 5 - 10 cm before the obstacle.
 - For all other drives: approx. 30 - 50 cm in front of the obstacle.
- Check the position of the front wheels. They must be in driving direction and at right angles to the obstacle.
- Approach slowly and keep at a consistent speed until the rear wheels have also passed over the obstacle.

Descending

The approach to descend an obstacle is the same as to ascend it with the difference that you need not stop before descending.

- Descend the obstacle very slowly.

Right

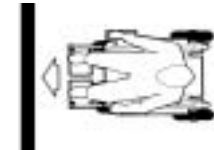

Wrong



5.3 Driving up and down gradients

For information concerning the maximum safe slope, please see chapter "**Technical specifications**" starting on page **109**.



WARNING: Danger of tipping over!

- *Only ever drive downhill at a maximum of 2/3 of the top speed. Avoid sudden changes of direction or abrupt braking when driving on slopes.*
 - *Always return the backrest of your seat or the seat tilt (if adjustable seat tilt is available) to an upright position before ascending slopes. We recommend that you position the seat backrest or the seat tilt slightly to the rear before descending slopes.*
 - *Always lower the lifter (if fitted) to its lowest position before ascending or descending a slope.*
 - *Never attempt to ascend or descend a slope on slippery surfaces or where there is a danger of skidding (such as wet pavement, ice etc).*
 - *Avoid trying to get out of the vehicle on an incline or a gradient.*
 - *Always drive straight in the direction the road or path you are on goes, rather than attempting to zigzag.*
 - *Never attempt to turn around on an incline or a slope.*
-

5.4 Parking and stationary

When parking your vehicle or if your vehicle is stationary for a prolonged period:

- Switch the vehicle's power system off (ON-/OFF key).
- Activate your anti-theft lock, if existing.

5.4.1 Activating and deactivating the manual wheel lock

The manual wheel locks are located on the left and right sides above the wheels.

- Pull the lever (1) upwards and backwards till it audibly locks in place. The manual wheel lock is activated.
- To release the wheel lock, push the lever (1) completely forward and downward again.



5.5 Use on public roads

If you wish to use your wheelchair on public roads and lighting is required by national legislation, then your wheelchair needs to be equipped with an appropriate lighting system.

Please contact your Invacare ® dealer if you have any questions.

6 Pushing the wheelchair in freewheel mode

The motors of the wheelchair are equipped with automatic brakes, preventing that the wheelchair starts rolling out of control when the joystick box is switched off. When pushing the wheelchair manually whilst freewheeling, the magnetic brakes must be disengaged.

6.1 Disengaging Motors



Danger of the vehicle running away!

- *When the motors are disengaged (for push operation whilst freewheeling), the electromagnetic motor brakes are deactivated! When the vehicle is parked, the levers for engaging and disengaging the motors must without fail be locked firmly into the "DRIVE" position (electromagnetic motor brakes activated)!*
-



NOTE:

The motors may only be disengaged by an attendant, not by the user!

This ensures that the motors are only disengaged if an attendant is available to secure the wheelchair and prevent unintended rolling.

The disengaging levers for the motors are located at the rear on the motor.

Disengaging motors:

- Switch off remote.
- Rotate the engaging lever (1) to the side (position B).
The motors are now disengaged.

Re-engaging motors

- Rotate the engaging lever (1) to the rear (position A).
The motors are now re-engaged.



7 Remotes

Your wheelchair may be equipped with one of several different remotes. For information on the different functions and how to operate a particular remote, please see its corresponding User Manual (enclosed).

8 Adjusting the wheelchair to the user's seating posture

8.1 Adjusting the armrests and the control panel

8.1.1 Adapting the control panel to the length of the user's arm

- Release wing nut (1) .
- Adjust the remote by pushing it forwards or backwards to the required location.
- Retighten the screw.



8.1.2 Setting the height of the remote

- Release wing nut (1) .
- Adjust remote to required height.
- Retighten the wing nuts.



8.1.3 Setting the height of the armrests

- Loosen the hand screw (1).
- Adjust armrest to required height.
- Retighten the hand nut.



8.1.4 Adjusting the width of the armrests

The distance between the armrests can be adjusted by 4 cm on both sides (8 cm in total).



WARNING! Danger of serious injury if an armrest falls out of it's fixation tube, due to it having been adjusted to a width that exceeds the specified value!

- *The width adjustment brackets have small stickers on them with markings and the word "STOP"! The armrest must never be pulled out past the point where the word "STOP" is fully legible!*
- *Always tighten the fixation screws tightly after adjustments are made!*



Pre-requisites:

- 1x 5 mm hexagon socket spanner

Where to find the adjustment screws

The figure below shows the position of the screws (1) which allows armrest width adjustment (only the right-hand side is shown in the illustration).

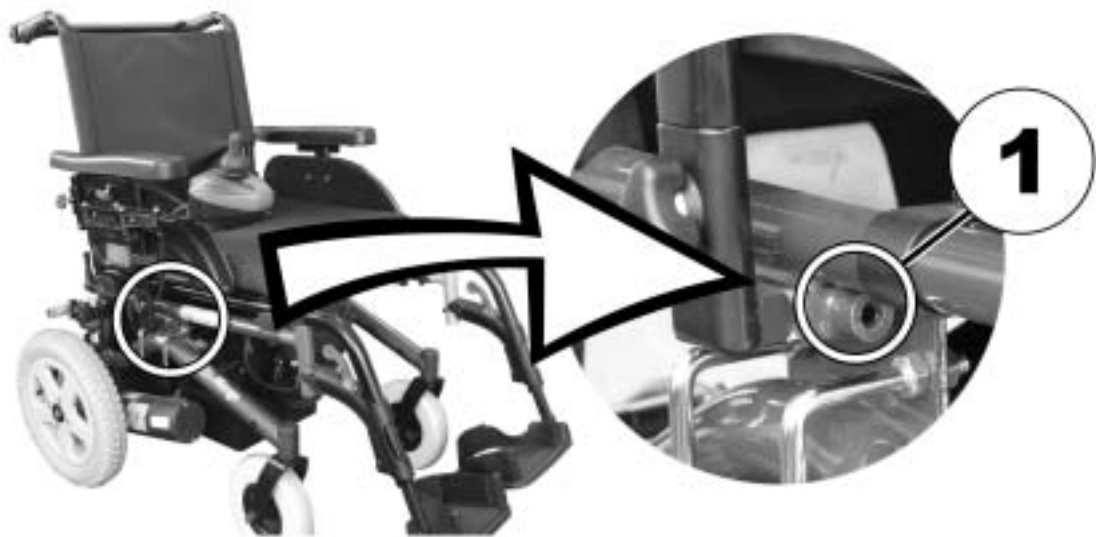

Doing the adjustment

- Loosen screw (1)
- Adjust armrest to required position.
- Retighten the screw.
- Repeat this procedure for the second armrest.



8.2 Adjusting the backrest

8.2.1 Gas spring angle adjustment

The levers (1) for adjusting the backrest are located on the push handles.

The inclination can be infinitely adjusted within a range of + 3° and + 38°.

Adjusting the backrest:

- Pull both levers (1) upwards.
- Adjust backrest by moving it forward or backwards.
- Release the lever again. The backrest will engage.



8.2.2 Manual angle adjustment

The levers (1) for adjusting the backrest are located on the push handles.

The inclination can be adjusted to four positions 3°, 13°, 23° and 33°.

Adjusting the backrest:

- Pull both levers (1) upwards.
- Adjust backrest by moving the backrest forward or backwards.
- Release the lever again. Move the backrest very slightly forward or backwards till it locks in place.



8.2.3 Adjusting the tension adjustable backrest upholstery

- Remove the backrest cushion (attached with Velcro strips) by pulling it up and off to access the adjustment straps.



- Adjust the tension of the individual straps as desired.
- Replace the backrest cushion.



8.3 Folding the backrest over



WARNING! Danger of most severe injury or death, if a wheelchair with a folding backrest is used as a vehicle seat!

A wheelchair with a folding backrest does not fulfil the requirements of ISO 7176-19:2001. Using a wheelchair that does not fulfil these requirements as a vehicle seat can lead to the most severe injuries and even death in the event of a traffic accident.

- *Never use a wheelchair with a folding backrest as a vehicle seat or to transport the user in a vehicle.*
-



CAUTION: Risk of injury from the backrest folding over during use!

If the folding backrest has not engaged properly, it may fold backwards unexpectedly when load is placed on it and you may fall from the wheelchair.

- *Before using the wheelchair, make sure that the backrest is folded up and the hinges have engaged.*
-



CAUTION: Risk of getting fingers caught!

When folding up the backrest, it is possible that you might catch your fingers in the hinges.

- *Keep your fingers away from the hinges, in order to avoid injuries.*
-

With the folding backrest, you can fold over the top half of the backrest backwards.

Folding the backrest over:

- Pull both levers (1) upwards.
- Fold the upper half of the backrest backwards.

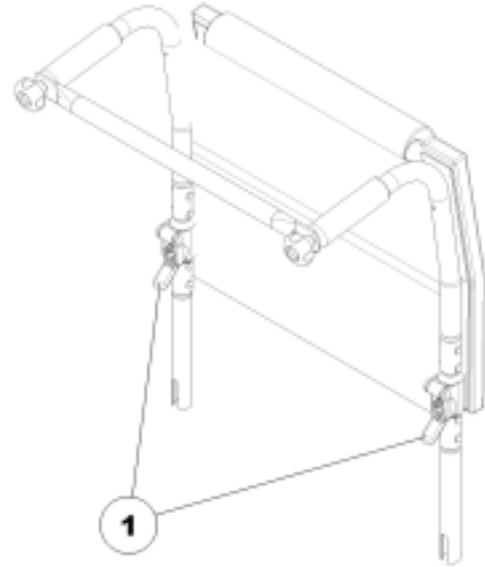

Folding the backrest up:

- Fold the upper half of the backrest up.
The hinges engage audibly.

8.4 Postural belts

A postural belt is an option which can either be fixed to the wheelchair ex-works or can be retrofitted by your specialist dealer. If your wheelchair is fitted with a postural belt, your specialist dealer will have informed you about fitting and usage.

The postural belt is used to help the wheelchair user keep an optimum sitting position. Correct use of the belt assists the user in sitting securely, comfortably and well-positioned in the wheelchair, especially for such users who do not have such a good sense of balance while sitting.



NOTE:

We recommend using the postural belt whenever the wheelchair is used. The belt should be tight enough to ensure that you are sitting comfortably and that your body is in the correct sitting position.

8.4.1 Types of postural belts

Your wheelchair can be fitted with the following postural belt types ex-works. If your wheelchair has been fitted with a different belt to those listed below, please ensure that you have received the manufacturer's documentation with regard to correct fitting and use.

Belt with metal buckle, adjustable one side

Belt can only be adjusted on one side which can result in the buckle not sitting centrally.



Belt with metal buckle, adjustable both sides

Belt can be adjusted on both sides. This means that the buckle can be centrally positioned.



8.4.2 Adjusting the postural belt correctly

- Ensure that you are sitting correctly, which means that you are sitting right at the back of the seat, your pelvis is positioned erect and as symmetrically as possible, not to the front, to the side or at one edge of the seat.
- Position the postural belt so that your hipbones can be easily felt above the belt.
- Adjust the belt length using one of the adjustment aids described above. The belt should be adjusted so that you can fit a flat hand between the belt and your body.
- The buckle should be positioned as centrally as possible. In doing so, please carry out adjustments on both sides as much as possible.
- Please check your belt every week to ensure that it is still in good working condition; to ensure it has no damage or wear, and that it is fixed properly to the wheelchair. If the belt is only fastened with a bolted connection, ensure that the connection has not loosened or undone. You can find more information about maintenance work on belts in the service manual, which is available from Invacare®.

8.5 Headrest



CAUTION: Danger of injury if the power wheelchair is used as a vehicle seat without a headrest! This can lead to hyperextension of the neck if a collision occurs!

- *It is recommended to use a headrest during transport. The Invacare® headrest for this wheelchair (available as an option) is the perfect solution for use during transport.*
- *The headrest must be adjusted to the ear height of the user.*



- Loosen the clamping levers (1) to adjust the height of the headrest.
- Adjust the headrest to the required height.
- Retighten clamping levers.
- Loosen the clamping lever (2) to adjust the angle of the headrest.
- Adjust to the required position.
- Retighten clamping lever.



8.6 Adjusting and removing the tray



CAUTION: Injury hazard or material damage if a power wheelchair which is fitted with a table is transported in a vehicle!

- *If a table is fitted, always remove it before transporting the wheelchair.*



8.6.1 Laterally adjusting the tray

- Loosen the wing-screw (1).
- Adjust the tray towards the left or right.
- Re-tighten wing-screw.



8.6.2 Adjusting the depth of the tray / removing the tray

- Loosen the wing-screw (1).
- Adjust the table to the desired depth (or remove it entirely).
- Re-tighten the screw.



8.6.3 Swinging the tray away to the side

The tray can be swivelled up and away to the side to allow the user to get in and out of the mobility device



CAUTION! Risk of injury! When the tray is raised it does not lock in place in this position!

- *Do not tilt the tray up and leave it leaning in this position.*
 - *Never attempt to drive with the tray tilted up.*
 - *Always lower the tray in a controlled manner.*
-

The tray can be swivelled upwards and pushed to the side as illustrated to enable getting on and off.



9 Adjusting footrests and legrests

9.1 Standard legrests

9.1.1 Swivelling the footrest outward and/or removing

The small release lever is to be found in the upper part of the legrest (1). When the legrest is released it can be swivelled inward or outward to facilitate access and also be removed completely.



- Push the release lever inward or outward. The legrest is released.
- Swivel the legrest inward or outward.
- To remove the legrest simply pull upward.



9.1.1.1 Adjusting the length



Pre-requisites:

- 1x 5 mm hexagon socket spanner
-

- Loosen the screw (1) using the Allen key, but do not remove completely.
- Set the legrest to the desired length.
- Re-tighten the screw.



9.2 Manually height-adjustable legrest

9.2.1 Swivelling the footrest outward and/or removing

The unlocking knob is located on the top section of the legrests. When the legrest is unlocked, it can be swivelled to the inside or outside to facilitate getting in, or can be completely removed.

- Press the unlocking knob (1) and remove the legrests upwards.

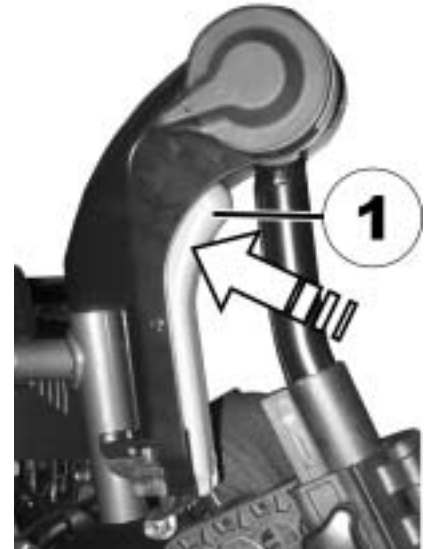

9.2.2 Adjusting the angle



PLEASE NOTE: Danger of crushing!

- *Do not reach inside the swivelling range of the legrest!*
-



PLEASE NOTE: Danger of injury due to incorrect adjustment of the footrests and legrests.

- *Before and during every journey it is imperative to ensure that the legrests contact neither the castor wheels nor the ground!*
-

- Press the unlocking lever (1) down. Adjust the legrest to the required angle.
- Release the unlocking lever. The legrest engages.



9.2.3 Adjusting legrest length



PLEASE NOTE: Danger of injury due to incorrect adjustment of the footrests and legrests.

- *Before and during every journey it is imperative to ensure that the legrests contact neither the castor wheels nor the ground!*
-



Pre-requisites:

- 1x 5 mm hexagon socket spanner
-

- Loosen bolt (1) with the Allen key.
- Adjust to required length.
- Retighten the screw.



9.2.4 Adjusting the calf support depth

The calf support has four depth settings.



Pre-requisites:

- 1x 4 mm Allen key
-

- Swivel the calf support to the front.
- Release bolt (1) with the Allen key and remove.
- Set the nut on the other side to the required depth.
- Adjust the calf support to match the depth of the nut, put the screw back in and tighten.



9.2.5 Adjusting the calf support height

- Loosen the hand screw (1).
- Adjust to required position.
- Retighten the wing nuts.

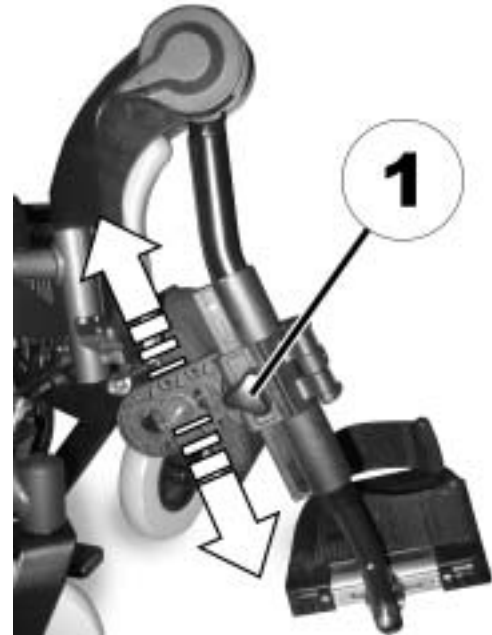

9.2.6 Adjusting the angle and depth adjustable foot plate



Pre-requisites:

- 1x 5 mm Allen key
-

- Use the Allen key to loosen the set screw on the foot plate (1).
- Adjust the foot plate to the desired angle or depth.
- Re-tighten the screw.



10 Electrical system

10.1 Electronics protection system

The vehicle drive electronics is fitted with an overload protection.

If the drive is severely overloaded over a long period (e.g. during steep climbs) and, above all, at simultaneous high external temperatures, the electronic system can overheat. In this case, the vehicle performance is gradually reduced until it comes to a standstill. The status display shows a corresponding blink code (please refer to the user manual for your remote). If you switch the drive electronics off and then on again, the error message is deleted and the electronics can be switched on again. It can however take up to five minutes until the electronics has cooled down enough for the drives to apply their full performance.

If the drive is blocked due to an insurmountable obstacle, for example a kerb or similar which is too high, and the driver attempts to run the drive for more than 20 seconds against this obstacle, the electronic system switches the drives off to avoid damage. The status display shows a corresponding flash code (please refer to the user manual for your remote). If you switch the drive electronics off and then on again, the error message is deleted and the electronics can be switched on again.

10.1.1 The main circuit breakers



NOTE

The circuit breakers are located on the left sides of the battery boxes. If the electrical system draws too much power for a period of time, one or both may overheat and pop out. To reactivate the electrical system, wait a few minutes until they have cooled down a bit, then push them back in.

The illustration at right shows the positions of the circuit breakers (1) on the battery boxes.



10.2 Batteries

Power is supplied by two 12 V batteries. The batteries are maintenance-free and only need regular charging.

In the following, you find information on how to charge, handle, transport, store, maintain, and use batteries.

10.2.1 Charging the batteries

10.2.1.1 General information on charging

New batteries should always be fully charged once before their first use. New batteries will be at their full capacity after having run through approx. 10 - 20 charging cycles (break-in period). This break-in period is necessary to fully activate the battery for maximum performance and longevity. Thus, range and running time of your mobility device could initially increase with use.

Gel/AGM lead acid batteries do not have a memory effect as NiCd batteries.

10.2.1.2 General instructions on charging

Follow the instructions listed below to ensure safe use and longevity of the batteries:

- Charge 12 hours prior to initial usage.
- We recommend charging the batteries daily after every discharge even after partly discharge, as well as each night over night. Depending on the level of discharge, it can take up to 12 hours until the batteries are fully charged again.
- When the battery indicator reached the red LED range, charge the batteries for 16 hours minimum, neglecting the charge complete display!
- Try to provide a 24 hour charge once a week to make sure that both batteries are fully charged.

- Do not cycle your batteries at a low state of charge without regularly recharging them fully.
- Do not charge your batteries under extreme temperatures. High temperatures above 30 °C are not recommended for charging as well as low temperatures below 10 °C.
- Use only charging devices in Class 2. This class of chargers may be left unattended during charging. All charging devices which are supplied by Invacare® comply with these requirements.
- You cannot overcharge the batteries when using the charger supplied with your vehicle, or a charger that has been approved by Invacare®.
- Protect your charger from sources of heat such as heaters and direct sunlight. If the battery charger overheats, charging current will be reduced and the charging process delayed.

10.2.1.3 How to charge the batteries

Please see the instruction manuals for your remote and battery charger for the position of the charging socket and further information about charging the batteries.



WARNING!**Risk of explosion and destruction of batteries if the wrong battery charger is used!**

- *Only ever use the battery charger supplied with your vehicle, or a charger that has been approved by Invacare®.*

Risk of electric shock and damage to the battery charger if it gets wet!

- *Protect the battery charger from water.*
- *Always charge in a dry environment.*

Risk of short circuit and electric shock if the battery charger has been damaged!

- *Do not use the battery charger if it has been dropped or damaged.*

Risk of electric shock and damage to the batteries!

- *NEVER attempt to recharge the batteries by attaching cables directly to the battery terminals.*

Risk of fire and electric shock if a damaged extension cable is used!

- *Only ever use an extension cable if it is absolutely necessary. In case you must use one, make sure it is in good condition.*

Risk of injury if using the wheelchair during charging!

- *DO NOT attempt to recharge the batteries and operate the wheelchair at the same time.*
 - *DO NOT sit in the wheelchair while charging the batteries.*
-

- Switch off the mobility device.
- Connect the battery charger to the charger socket.
- Connect the battery charger to the power supply.

10.2.1.4 How to disconnect the batteries after charging

- Once charging is complete, first disconnect the battery charger from the power supply, then disconnect the plug from the remote.

10.2.2 Storage and Maintenance

Follow the instructions listed below to ensure safe use and longevity of the batteries:

- Always store the batteries fully charged.
- Do not leave the batteries in a low state of charge for an extended length of time. Charge a discharged battery as soon as possible.
- In case your mobility device is not used for a longer period of time (that is more than two weeks), the batteries must be charged at least once a month to maintain a full charge and always be charged before use.
- Avoid hot and cold extremes when storing. We recommend to store batteries at a temperature of 15 °C.
- Gel and AGM batteries are maintenance-free. Any performance issues should be handled by a properly trained mobility device technician.

10.2.3 Instructions on using the batteries



CAUTION! Risk of damaging the batteries.

- *Avoid ultra-deep discharges and never drain your batteries completely.*
-

- Pay attention to the Battery Charge Indicator! Charge the batteries when the Battery Charge Indicator shows that battery charge is low.

How fast the batteries discharge depends on many circumstances, such as ambient temperature, condition of the surface of the road, tyre pressure, weight of the driver, way of driving and utilisation of lighting.

- Try to charge the batteries always before you reach the red LED range.

The last 3 LED (two red and one orange) mean a remaining capacity of about 15 %.

- Driving with blinking red LED's means an extreme stress for the battery and should be avoided under normal circumstances.
- When only one red LED is blinking, the Battery Safe feature is enabled. From this time, speed and acceleration is reduced drastically. It will allow you to move the mobility device slowly out of a dangerous situation before the electronic finally cuts off. This is deep discharging and should be avoided.
- Be aware that for temperatures below 20 °C, the nominal battery capacity starts to decline. For example, at -10 °C the capacity is reduced to about 50 % of the nominal battery capacity.
- To avoid damaging the batteries, never allow them to be fully discharged. Do not drive on heavily discharged batteries if it is not absolutely necessary, as this will strain the batteries unduly and shorten their life expectancy.
- The earlier you recharge the batteries, the longer they live.
- The depth of discharge affects the cycle life. The harder a battery has to work, the shorter is its life expectancy.

Examples:

- One deep discharge stresses the same as 6 normal cycles (green /orange display off).
- The battery life is about 300 cycles at 80% discharge (first 7 LED off), or about 3000 cycles at 10% discharge (one LED off).



NOTE:

The number of LED can vary depending on the remote type.

- Under normal operation, once a month the battery should be discharged until all green and orange LED are off. This should be done within one day. A 16 hour charge afterwards is necessary as reconditioning.

10.2.4 Transporting batteries

The batteries supplied with your electric vehicle are not hazardous goods. This classification is based on the German GGVS Hazardous Goods Road Transport Ordinances, and the IATA/DGR Hazardous Goods Rail Transport / Air Transport Ordinances. Batteries may be transported without restrictions, whether by road, rail or by air. Individual transport companies have, however, guidelines which can possibly restrict or forbid certain transport procedures. Please ask the transport company regarding each individual case.

10.2.5 Handling batteries

10.2.5.1 General instructions on handling the batteries

- Never mix and match different battery manufactures or technologies, or use batteries that do not have similar date codes.
- Never mix gel with AGM batteries.
- Always have your batteries installed by a properly trained mobility device technician. They have the necessary training and tools to do the job safely and correctly.

10.2.5.2 How to handle damaged batteries correctly



WARNING:**Corrosion and burns from acid leakage if batteries are damaged!**

- *Remove clothes that have been soiled by acid immediately.*

After contact with skin:

- *Immediately wash affected area with lots of water.*

After contact with eyes:

- *Immediately rinse eyes under running water for several minutes; consult a physician.*
-

- Always wear safety goggles and appropriate safety clothing when handling damaged batteries.
- Place damaged batteries in an acid-resistant receptacle immediately after removing them.
- Only ever transport damaged batteries in an appropriate acid-resistant receptacle.
- Wash all objects that have come into contact with acid with lots of water.

Disposing of dead or damaged batteries correctly

Dead or damaged batteries can be given back to your dealer or directly to Invacare®.

10.2.5.3 Removing the batteries



CAUTION: Risk of fire and burns if battery poles are bridged!

- *When replacing the batteries the battery poles MUST NOT come into contact with metal parts of the wheelchair causing bridging.*
 - *Be sure to replace the battery pole caps after the batteries have been replaced.*
-



WARNING: Risk of fire and burns due to damage to the battery cables!

- *The battery cables and other cables are positioned in a cable duct above the batteries. The cable duct protects the cables against crushing and other damage. It may not be removed.*
-



Requirements:

- 1x jaw spanner 11 mm
-



PLEASE NOTE:

If your wheelchair is fitted with a lifter the seat unit must be pulled upward in order to access the batteries. This work should be carried out by at least two people.

- Open battery fixing strap (buckle).



- Remove battery cable connecting plugs on both sides (the figure only shows the right-hand side).



- Pull the rear battery box out towards the back.



- Open the battery retaining strap velcro fastening.



- Pull the battery retaining strap to the side over the edge of the battery box.



- Open the battery box.
- Pull the battery terminal caps (1) upwards and push them back to allow access to the battery terminals.
- Loosen battery terminal clamps with the spanner.
- Replace battery.
- Re-assembly is done in reverse order.



11 Care and maintenance



NOTE:

Have your vehicle checked once a year by an authorised Invacare® dealer in order to maintain it's driving safety and roadworthiness.

Cleaning the vehicle

When cleaning the vehicle, pay attention to the following points:

- Only use a damp cloth and gentle detergent.
- Do not use any abrasive or scouring liquids.
- Do not subject the electronic components to any direct contact with water.
- Do not use high-pressure cleaning devices.

Disinfection

Spray or wipe disinfection using a tested and recognised product is permitted. A list of the current permitted disinfectants is available from the Robert Koch Institute at <http://www.rki.de>.

Maintenance Jobs	When Delivered	Weekly	Monthly
Seat and backrest padding:			
- Check for perfect condition.			✓
Side part and armrest:			
- Are all fastening elements installed?	✓	✓	
- Can armrests / side parts be removed and installed without too much physical effort?		✓	
- Are armrests secured in their positions?		✓	
Legrests:			
- Do legrests lock into place without any problem (only applies to detachable legrests)?		✓	
Manually angle adjustable backrest:			
- Is the ratchet mechanism of the angle adjustment undamaged and in good working order?			✓
- Do the different adjustment functions work without any problem?			✓
Tyres:			
- Have tyres checked for specified air pressure (see Technical Specifications).	✓	✓	
Anti-tip wheels			
- Check that the anti-tip wheels are undamaged.		✓	
Castor wheels and forks			
- Castor wheels must rotate smoothly.		✓	
- Check fork bearing for firm seat (torque 15 Nm +/- 1,5 Nm).			✓
Drive wheels:			

- Check that the wheel is firmly attached to the axle and has no play, by pushing and pulling it from the side.			✓
- Rear wheels must turn without wobbling			✓
Electronics / Electrical System:			
- Check that all plug connections are undamaged and firmly connected.			✓
- Have all batteries been fully charged before the daily operation?	Before every trip		
- Are all electric bulbs of the lighting system (if applicable) in working order?	Before every trip		
Cleaning:			
- Clean all parts carefully.	When necessary		

Have your vehicle inspected and serviced once a year by your authorised dealer. A complete checklist of necessary maintenance work can be found in the Service Manual, which can be obtained from Invacare®.

12 Maintenance- and repair work

The following are instructions on maintenance and repairs that can be performed by the user. For the specifications of spare parts please see "**Technical specifications**" on page **109**, or consult the Service Manual, available from Invacare® (in this connection please see the addresses and phone numbers in section "**How can you get in touch with Invacare®?**" on page **3**). In case you require assistance, please contact your Invacare® Dealer.

12.1 Repairing a flat tyre



WARNING: Danger of damage or injury if the vehicle is accidentally set into motion during repairs!

- *Switch the power off (ON/OFF Button)!*
 - *Engage the motors!*
 - *Secure the vehicle against rolling away by placing wedges under the wheels!*
-



CAUTION: Risk of damage to the vehicle! Collisions can be caused if shim rings are removed from the drive wheels during installation work!

- *Shim rings are frequently placed between the drive shaft and the wheel hub to compensate tolerances. Collisions can be caused if these shim rings are removed and not re-installed! Please install all shim rings in exactly the same positions they were in before dismantling.*
-



CAUTION: Risk of injury if maintenance and repair work is not carried out in exact accordance with the instructions, including utilizing any special tools specified!

- *If you do not have access to all the required tools, then you should NOT attempt to perform the work!*
-

12.1.1 Repairing a flat tyre at the back (tyre type 3.00-8")



Injury hazard! If the wheel has been insufficiently secured during assembly, it can become loosened during driving!

- *When refitting the drive wheels, tighten the Torx screw that secures the wheel to the hub to a torque of 30 Nm!*
 - *Secure all screws using a suitable threadlock (e.g. Loctite 243)!*
-



Requirements:

- Torque wrench with ...
 - Allen bit 5 mm
 - Torx bit T40
 - Repair kit for tyre repair **or** a new inner tube.
 - Talcum powder
 - Threadlock Loctite (e.g. Loctite 243)
-

Removing the wheel

- Jack the vehicle up and place a block of wood underneath it to prop it up.
- Remove the countersunk screw (1) using the Torx bit.
- Remove the wheel from the axle.



EXPLOSION HAZARD! The wheel will explode if the air pressure is not released from the tyre before disassembling the wheel rim!

- *Always make sure to completely release the air pressure by pressing the pin in the centre of the valve!*

Repairing the flat tyre

- Remove the valve cap.
- Let the air out of the tyre completely by pressing the pin in the centre of the valve in.
- Remove the 5 cylinder head screws (back of the wheel, 2).
- Remove the rim halves from the tyre.
- Remove the inner tube from the tyre.
- Repair the inner tube and re-fit, or replace it with a new one.





NOTE

In case the old inner tube is to be repaired and used again, and it happens to get wet during repair, then it is easier to re-fit it if you powder it lightly with talcum powder.



NOTE

Re-assembly is done in reverse order. Make sure that the wheel is put back on the same side it was on, and that it runs in the same direction it did before it was removed.

- Re-fit the rim halves back into the tyre.
- Pump up the tyre a little.
- Insert the cylinder head screws in the rim and tighten to 10 Nm. Make sure the inner tube does not get pinched between the rims halves!
- Check to make sure that the tyre is squarely in place on the rim.
- Pump up the tyre to the recommended tyre pressure.
- Check to make sure that the tyre is still squarely and snugly in place on the rim.
- Screw the valve cap back on.
- Refit the wheel.
- Refit the Torx screw using threadlock and tighten to 30 Nm.

13 Transport



CAUTION: Injury hazard or material damage if a power wheelchair which is fitted with a table is transported in a vehicle!

- *If a table is fitted, always remove it before transporting the wheelchair.*



CAUTION: Danger of death or serious injury to the mobility device user and potentially any other nearby occupant of the vehicle, if a mobility device is secured using a 4-point tie-down system available from a third party supplier and the unladen weight of the mobility device exceeds the maximum weight for which the tie-down system is certified!

- *Make sure the weight of the mobility device does not exceed the weight for which the tie-down system is certified. Consult the tie-down manufacturer's documentation.*
- *If you are unsure how much your mobility device weighs, then you must have it weighed using calibrated scales.*

13.1 Transferring the wheelchair to a vehicle



WARNING: The wheelchair is in danger of tipping over if it is transferred to a vehicle while the driver is still seated in the wheelchair!

- *Transfer the wheelchair without the driver whenever possible!*
 - *If the wheelchair with the driver has to be transferred to a vehicle using a ramp, ensure that the ramp does not exceed the maximum safe slope (see chapter "**Technical specifications**" starting on page **109**)!*
 - *If the wheelchair has to be transferred to a vehicle using a ramp that does exceed the maximum safe slope (see chapter "**Technical specifications**" starting on page **109**), a winch must then be used! An attendant can then safely monitor and assist the transfer process!*
 - *Alternatively, a platform lift may be used!*
 - *Ensure that the total weight of the power wheelchair including the user does not exceed the maximum permitted total weight for the ramp or platform lift!*
 - *The wheelchair should always be transferred to a vehicle with the backrest in an upright position, the seat lifter lowered and the seat tilt in the upright position (see chapter "**Driving up and down gradients**" on page **38**)!*
-

13.2 Securing the wheelchair for transport without passengers



CAUTION: Injury hazard!

- *If you are unable to fasten your electric wheelchair securely in a transport vehicle, Invacare® recommends that you do not transport it!*
-

- Before transporting your wheelchair, make sure the motors are engaged and that the Joystick Box is switched off.
Invacare® strongly recommends that you additionally disconnect or remove the batteries. See "Removing batteries" on page **102**.
- Invacare® strongly recommends securing the wheelchair to the floor of the transporting vehicle.

13.3 Use of the wheelchair as a seat in a vehicle



Note

The following section does not apply to models or configurations which may not be used as a vehicle seat. These are identified by the following labels on the lashing eyes:



Please note

In order to use a wheelchair as a motor vehicle seat, it needs to be equipped with attachment points to enable anchoring in the motor vehicle. These accessories may be included in the standard scope of wheelchair order and delivery in some countries (UK for example), but may also be obtained from Invacare® as an option in other countries.

This power wheelchair complies with the requirements of ISO 7176-19:2001 and may be used as a vehicle seat in connection with an anchoring system that has been checked and approved in accordance with ISO 10542. The wheelchair has undergone a crash test in which it was anchored in the transporting vehicle's direction of travel. Other configurations were not tested. The crash test dummy was secured using pelvic and upper body safety belts. Both types of safety belt should be used in order to minimise the risk of injuries to head or upper body. It is imperative that the wheelchair is inspected by an authorised dealer before being used again after being involved in a crash. Alterations to the wheelchair anchoring points may not be carried out without the manufacturer's permission.



Caution: There is a danger of injury if the wheelchair is not properly secured during use as a vehicle seat!

- *If possible, the user should always leave the wheelchair to use a vehicle seat and the safety belts provided with the vehicle.*
 - *The wheelchair should always be anchored facing in the transport vehicle's intended direction of travel.*
 - *The wheelchair must always be secured in accordance with the wheelchair and anchoring system manufacturers' operating manual.*
 - *Always remove and secure any accessory parts fixed to the wheelchair such as chin controls or tables.*
 - *If your wheelchair is equipped with an angle adjustable backrest, then it must be placed in an upright position.*
 - *Fully lower elevated legrests, if fitted.*
 - *Fully lower the seat lifter, if fitted.*
-



WARNING: Danger of injury exists if a power wheelchair that is not equipped with leak-proof batteries is transported in a vehicle!

- *Only ever use leak-proof batteries!*
-



WARNING: Danger of injury or damage to the wheelchair or to the transporting vehicle, if the legrests are in a raised position while the wheelchair is used as a vehicle seat!

- *Always completely lower height-adjustable legrests, if fitted.*
-

13.3.1 How the wheelchair is anchored in a vehicle for use as a vehicle seat

The power wheelchair is fitted with four anchoring points, which are labelled with the symbol shown on the right. Snap hooks or belt loops can be used for fixation.



- Secure the wheelchair in the front (1) and rear (2) with the anchoring system belts (only left side visible in the picture). The kerb climber does not need to be removed.
- Secure the wheelchair by tensioning the belts in accordance with the manufacturer's anchoring system operating manual.

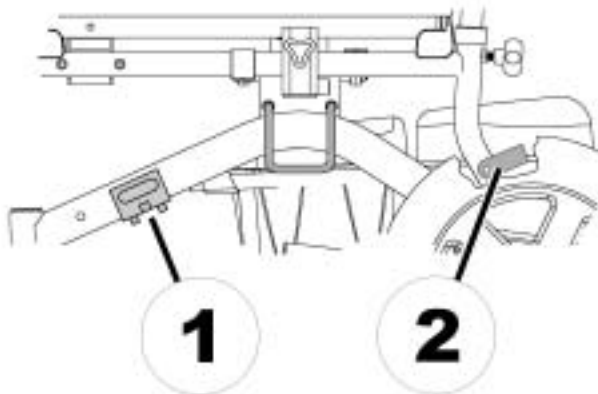



13.3.2 How the user is secured within the wheelchair



CAUTION: There is a danger of injury if the user is not properly secured within the wheelchair!

- *Even if the wheelchair is fitted with a postural belt, this is no substitute for a proper safety belt which complies with ISO 10542 in the transport vehicle. Always use the safety belt installed in the transport vehicle.*
 - *Safety belts must be in contact with the user's body. They must not be held at a distance from the user's body using parts of the wheelchair such as armrests or wheels. Refer to the illustration on page 97.*
 - *Safety belts must be pulled as tightly as possible without causing the user discomfort. Refer to the illustration on page 97.*
 - *Safety belts must not be positioned while twisted.*
 - *Ensure that the third seatbelt anchorage point is not fixed directly to the vehicle floor, but to one of the vehicle uprights.*
-



CAUTION: Danger of injury if the power wheelchair is used as a vehicle seat without a headrest! This can lead to hyperextension of the neck if a collision occurs!

- *It is recommended to use a headrest during transport. The Invacare® headrest for this wheelchair (available as an option) is the perfect solution for use during transport.*
- *The headrest must be adjusted to the ear height of the user.*





Seat belts may not be held at a distance from the user's body using parts of the wheelchair such as armrests or wheels.

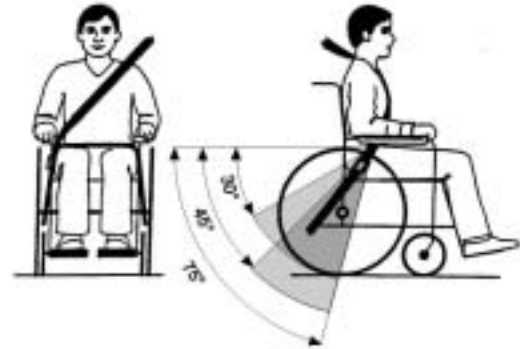

The pelvic belt should be positioned in the area between the user's pelvis and thighs so that it is unobstructed and not too loose. The ideal angle of the pelvic belt to the horizontal is between 45° and 75°. The maximum permissible angle is between 30° and 75°. The angle should never be less than 30°!

The safety belt installed in the transporting vehicle should be applied as shown in the illustration at right.

- 1) Centre line of the body
- 2) Centre of the sternum

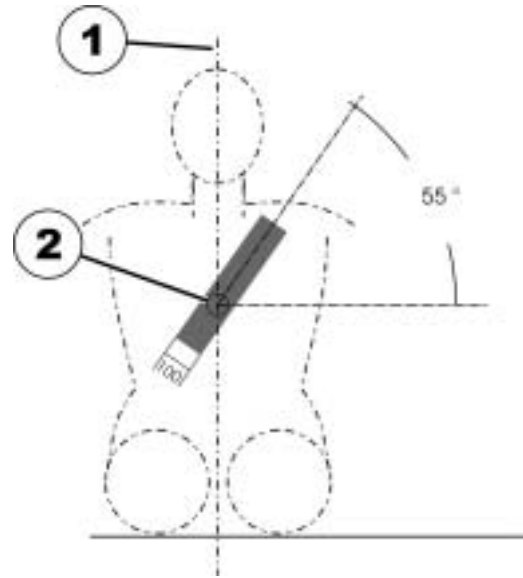

13.4 Dismantling the wheelchair for transport

To dismantle and fold the wheelchair together for transport, please proceed as follows.

- Remove legrests.
- Remove the kerb climber (available as option and not always fitted).
- Remove the battery cable.
- Remove the battery case.
- Remove the backrest cross strut.
- Remove the seat cushion.
- Fold the wheelchair together and load it.

The wheelchair is reassembled in reverse order to the above sequence.

13.4.1 Removing legrests



NOTE:

Disassembly of the legrests is dependent on their type. For more information about this, please see Chapter **Adjusting footrests and legrests** on page 59.

13.4.2 Removing the kerb climber

The kerb climber is fitted with quick release axles.

The quick release axles are fitted with securing balls (1) which prevent the quick release axles sliding out of the mounting.

- The securing balls are released by pressing in the unlocking knob (2). This means that the kerb climber can be quickly removed and refitted.



Removing the kerb climber

- Press the unlocking knobs and pull the quick release axles (1) out of the mountings.
- Remove the kerb climber from the mountings.



13.4.3 Removing batteries

- Open battery fixing strap.



- Remove battery cable connecting plugs on both sides (the figure only shows the right-hand side).



- Pull the rear battery box out towards the back.



13.4.4 Removing backrest frame cross strut

Removing the cross strut:

- Release the knurled screws on both sides (1) of the cross strut.
- Unhook the cross strut at the right-hand knurled screw.



13.4.5 Folding the wheelchair

Stage 1



Removing the seat cushion (1).

Stage 2



There are two locks (1) located right and left under the seat which need to be opened in order to fold the chair together.

Stage 3



Press the locking lever (1) inwards and downwards.

Stage 4



**Open the lock inwards.
Repeat the procedure on the
other side.**

Stage 5



**Tilt the wheelchair slightly to
the side and press it
together.**

Stage 6



13.4.6 Reassembling the wheelchair



NOTE:

Reassembly of the wheelchair takes place in reverse order to disassembly.

14 Refurbishment

The product is suitable for refurbishment. Actions to be carried out:

- Cleaning and disinfection. Please see chapter "Care and maintenance" on page **81**.
- Inspection according to service plan. Please consult service instructions, available from Invacare®.
- Adaptation to the user. Please see chapter "Adjusting the wheelchair to the user's seating posture" on page **42**.

15 Disposal

- The equipment wrapping is potentially recyclable.
- The metal parts are used for scrap metal recycling.
- The plastic parts are used for plastic recycling.
- Electric components and printed circuit boards are disposed of as electronic scrap.
- Exhausted or damaged batteries can be returned to your medical equipment supplier or Invacare®.
- Disposal must be carried out in accordance with the respective national legal provisions.
- Ask your city or district council for details of the local waste management companies.

16 Technical specifications

The technical information provided hereafter applies to a standard configuration or represents maximum achievable values. These can change if accessories are added. The precise changes to these values are detailed in the sections for the respective accessories.

Permissible operating and storage conditions	
Temperature range for operation according to ISO 7176-9:	• -25° ... +50 °C
Temperature range for storage according to ISO 7176-9:	• -40° ... +65 °C

Electrical system	
Motors	• 2 x 110 W
Batteries	• 2 x 12 V/30 Ah, leakproof/gel • 2 x 12 V/40 Ah, leakproof/gel
Main fuse	• 2x 40 A

Charging device	
Output current	• 8 A ± 8 %
Output voltage	• 24 V nominal (12 cells)
Input voltage	• 200 – 250 V nominal
Operating temperature (surroundings)	• -25° ... +50 °C
Storage temperature	• -40° ... +65 °C

Drive wheel tyres	
Tyre type	• 330 mm (12½" x 2¼") pneumatic or puncture-proof
Tyre pressure	The recommended maximum tyre pressure in bar or kpa is marked on the side wall of the tyre or the rim. If more than one value is listed, the lower one in the corresponding units applies. (Tolerance = -0.3 bar, 1 bar = 100 kpa)

Steering wheel tyres	
Tyre type	<ul style="list-style-type: none"> • 200 x 50 mm pneumatic or solid rubber
Tyre pressure	The recommended maximum tyre pressure in bar or kpa is marked on the side wall of the tyre or the rim. If more than one value is listed, the lower one in the corresponding units applies. (Tolerance = -0.3 bar, 1 bar = 100 kpa)

Driving characteristics	
Speed	<ul style="list-style-type: none"> • 3 km/h • 6 km/h
Min. braking distance	<ul style="list-style-type: none"> • 400 mm (3 km/h) • 1000 mm (6 km/h)
Max. safe slope *****	<ul style="list-style-type: none"> • 9° (15,8 %) according to manufacturer's specifications with 120 kg payload, 4° seat angle, 20° backrest angle
Max. climbable obstacle height	<ul style="list-style-type: none"> • 60 mm (without kerb climber) • 100 mm (with kerb climber)
Turning diameter	<ul style="list-style-type: none"> • 1800 mm
Drive range in accordance with ISO 7176-4:2008 ***	<ul style="list-style-type: none"> • 20 km (30 Ah batteries) • 25 km (40 Ah batteries)

Dimensions	
Total height	<ul style="list-style-type: none"> • 940 mm
Drive unit width	<ul style="list-style-type: none"> • 530, 570, 610, 680 mm
Total length (incl. standard legrests)	<ul style="list-style-type: none"> • 1070 mm
Seat height ****	<ul style="list-style-type: none"> • 470 mm
Seat width (armrest adjustment range in brackets)	<ul style="list-style-type: none"> • 350, 400, 450, 500 mm (80 mm**)

Dimensions	
Seat depth	<ul style="list-style-type: none"> • 400, 450, 500 mm
Backrest height ****	<ul style="list-style-type: none"> • 450, 530 mm
Seat cushion thickness	<ul style="list-style-type: none"> • 50 mm
Backrest angle	<ul style="list-style-type: none"> • +3° ... +35° (gas spring) • +14° (fixed) • 3°, 13°, 23°, 33° (manual)
Armrest height (standard armrest)	<ul style="list-style-type: none"> • 270 ... 340 mm
Legrest length	<ul style="list-style-type: none"> • 350 ... 460 mm
Seat angle	<ul style="list-style-type: none"> • 2°

Weight *****	
Empty weight (seat width 400 mm)	<ul style="list-style-type: none"> • 64 kg (30 Ah batteries) • 72 kg (40 Ah batteries)

Component weights	
Batteries 30 Ah	<ul style="list-style-type: none"> • approx. 11 kg per battery
Batteries 40 Ah	<ul style="list-style-type: none"> • approx. 15 kg per battery

Loading	
Max. load	<ul style="list-style-type: none"> • 120 kg

Axle loads	
Max. front axle load	<ul style="list-style-type: none"> • 96 kg
Max. rear axle load	<ul style="list-style-type: none"> • 123 kg

* Approximate.

** Width adjustable for side panel adjustment.

*** Note: The drive range of an electric wheelchair is strongly influenced by external factors, such as the charging state of the batteries, surrounding temperature, local topography, road surface characteristics, tyre pressure, weight of driver, drive style and use of batteries for lighting, servos etc.

The specified values are theoretical maximum achievable values measured according to ISO 7176-4:2008.

**** Measured without seat cushion

***** The actual kerb weight depends on the fittings your mobility aid has been supplied with. Every Invacare® mobility aid is weighed when leaving the works. Please refer to the nameplate for the kerb weight (including batteries) measured.

***** Static stability according to ISO 7176-1 = 9° (15,8 %)
Dynamic stability according to ISO 7176-2 = 6° (10,5 %)

17 Inspections Performed

It is confirmed by stamp and signature that all jobs listed in the inspection schedule of the Service and Repair Instructions have been properly performed. The list of the inspection jobs to be performed can be found in the Service Manual which is available through Invacare®.

<u>Delivery Inspection</u>	<u>1st Annual Inspection</u>
Stamp of authorised Dealer / Date / Signature	Stamp of authorised Dealer / Date / Signature
<u>2nd Annual Inspection</u>	<u>3rd Annual Inspection</u>
Stamp of authorised Dealer / Date / Signature	Stamp of authorised Dealer / Date / Signature
<u>4th Annual Inspection</u>	<u>5th Annual Inspection</u>
Stamp of authorised Dealer / Date / Signature	Stamp of authorised Dealer / Date / Signature

Order No. of this Manual: 1513283.DOC
Release Date: 2012-07-03

English