

videolarm™

Creating tomorrow's security, today.

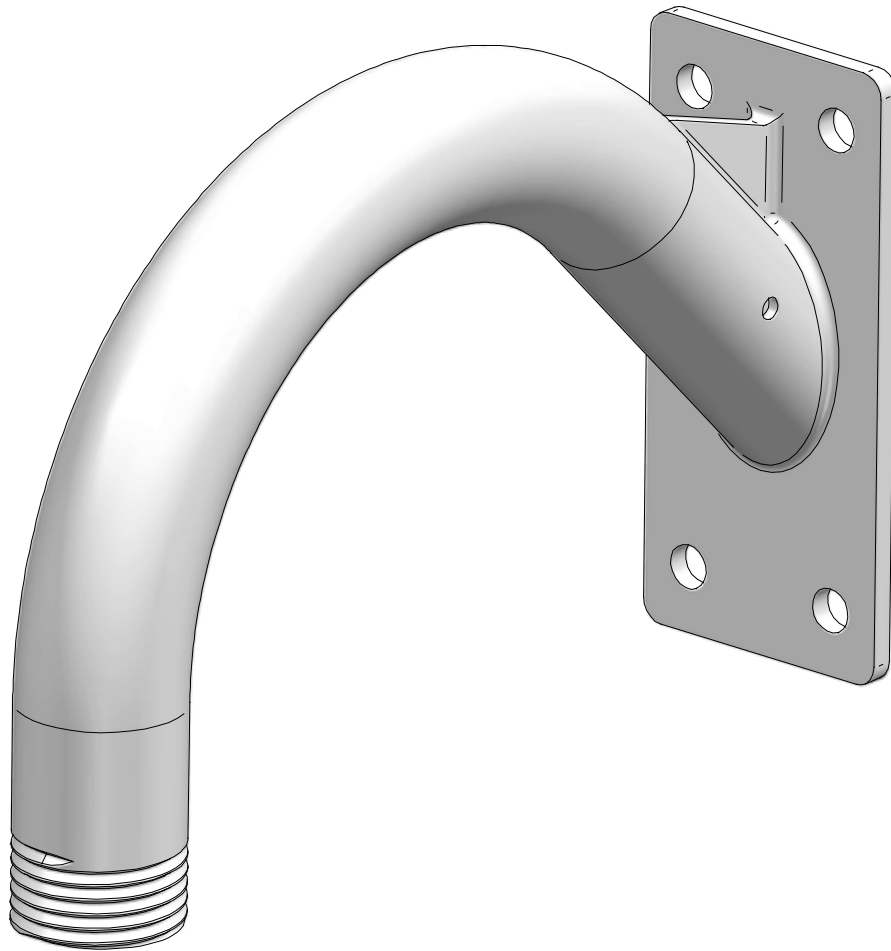

www.videolarm.com

WM20G

Outdoor Dome Housing Brackets and Mounts

Installation and Operation Instructions for the following models:

WM20G Aluminum gooseneck wall brackets, includes 1½" NPT

HARDWARE:
(Hardware NOT included)

Before attempting to connect or operate this product,
please read these instructions completely.

81-IN5208R1

IMPORTANT SAFEGUARDS

- 1 Read these instructions.
- 2 Keep these instructions.
- 3 Heed all warnings
- 4 Follow all instructions.
- 5 Do not use this apparatus near water.
- 6 Clean only with damp cloth.
- 7 Do not block any of the ventilation openings. Install in accordance with the manufacturers instructions.
- 8 Cable Runs- All cable runs must be within permissible distance.
- 9 Mounting - This unit must be properly and securely mounted to a supporting structure capable of sustaining the weight of the unit.

Accordingly:

- a. The installation should be made by a qualified installer.
 - b. The installation should be in compliance with local codes.
 - c. Care should be exercised to select suitable hardware to install the unit, taking into account both the composition of the mounting surface and the weight of the unit.
- 10 Do not install near any heat sources such as radiators, heat registers, stoves, or other apparatus (including amplifiers) that produce heat.
 - 11 Do not defeat the safety purpose of the polarized or grounding-type plug. A polarized plug has two blades with one wider than the other. A grounding type plug has two blades and a third grounding prong. The wide blade or the third prong are provided for your safety. When the provided plug does not fit into your outlet, consult an electrician for replacement of the obsolete outlet.
 - 12 Protect the power cord from being walked on or pinched particularly at plugs, convenience receptacles, and the point where they exit from the apparatus.
 - 13 Only use attachment/ accessories specified by the manufacturer.
 - 14 Use only with a cart, stand, tripod, bracket, or table specified by the manufacturer, or sold with the apparatus. When a cart is used, use caution when moving the cart/ apparatus combination to avoid injury from tip-over.
 - 15 Unplug this apparatus during lightning storms or when unused for long periods of time.
 - 16 Refer all servicing to qualified service personnel. Servicing is required when the apparatus has been damaged in any way, such as power-supply cord or plug is damaged, liquid has been spilled or objects have fallen into the apparatus, the apparatus has been exposed to rain or moisture, does not operate normally, or has been dropped.

Be sure to periodically examine the unit and the supporting structure to make sure that the integrity of the installation is intact. Failure to comply with the foregoing could result in the unit separating from the support structure and falling, with resultant damages or injury to anyone or anything struck by the falling unit.

UNPACKING

Unpack carefully. Electronic components can be damaged if improperly handled or dropped. If an item appears to have been damaged in shipment, replace it properly in its carton and notify the shipper.

Be sure to save:

- 1 The shipping carton and packaging material. They are the safest material in which to make future shipments of the equipment.
- 2 These Installation and Operating Instructions.

SERVICE

If technical support or service is needed, contact us at the following number:

TECHNICAL SUPPORT
AVAILABLE 24 HOURS
1 - 800 - 554 - 1124

SAFETY PRECAUTIONS

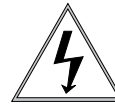
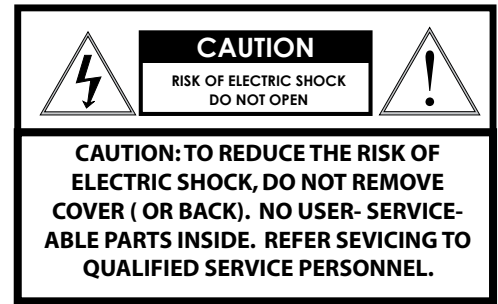

The lightning flash with an arrowhead symbol, within an equilateral triangle, is intended to alert the user to the presence of non-insulated "dangerous voltage" within the product's enclosure that may be of sufficient magnitude to constitute a risk to persons.

Este símbolo se piensa para alertar al usuario a la presencia del "voltaje peligroso no-aislado" dentro del recinto de los productos que puede ser un riesgo de choque eléctrico.

Ce symbole est prévu pour alerter l'utilisateur à la présence "de la tension dangereuse" non-isolée dans la clôture de produits qui peut être un risque de choc électrique.

Dieses Symbol soll den Benutzer zum Vorhandensein der nicht-Isolier "Gefährdungsspannung" innerhalb der Produkteinschließung alarmieren die eine Gefahr des elektrischen Schlages sein kann.

Este símbolo é pretendido alertar o usuário à presença "di tensão perigosa non-isolada" dentro do cerco dos produtos que pode ser um risco de choque elétrico.

Questo simbolo è inteso per avvertire l'utente alla presenza "di tensione pericolosa" non-isolata all'interno della recinzione dei prodotti che può essere un rischio di scossa elettrica.



The exclamation point within an equilateral triangle is intended to alert the user to presence of important operating and maintenance (servicing) instructions in the literature accompanying the appliance.

Este símbolo del punto del exclamation se piensa para alertar al usuario a la presencia de instrucciones importantes en la literatura que acompaña la aplicación.

Ce symbole de point d'exclamation est prévu pour alerter l'utilisateur à la présence des instructions importantes dans la littérature accompagnant l'appareil.

Dieses Ausruf Punktsymbol soll den Benutzer zum Vorhandensein de wichtigen Anweisungen in der Literatur alarmieren, die das Gerät begleitet.

Este símbolo do ponto do exclamation é pretendido alertar o usuário à presença de instruções importantes na literatura que acompanha o dispositivo.

Questo simbolo del punto del exclamation è inteso per avvertire l'utente alla presenza delle istruzioni importanti nella letteratura che accompagna l'apparecchio.



LIMITED WARRANTY FOR VIDEOLARM INC. PRODUCTS

VIDEOLARM INC. warrants this Product to be free from defects in material or workmanship, as follows:

PRODUCT CATEGORY	PARTS	LABOR
All Enclosures and Electronics	Three (3) Years	Three (3) Years
Pan/Tilts	Three (3) Years **6 months if used in autoscan	Three (3) Years **6 months if used in autoscan
Poles/PoleEvators	Three (3) Years	Three (3) Years
Warrior/Q-View/I.R. Illuminators/SView	Five (5) Years	Five (5) Years
Controllers	Three (3) Years	Three (3) Years
Power Supplies	Three (3) Years	Three (3) Years
Accessory Brackets	Three (3) Years	Three (3) Years

During the labor warranty period, to repair the Product, Purchaser will either return the defective product, freight prepaid, or deliver it to Videolarm Inc. Decatur GA. The Product to be repaired is to be returned in either its original carton or a similar package affording an equal degree of protection with a RMA # (Return Materials Authorization number) displayed on the outer box or packing slip. To obtain a RMA# you must contact our Technical Support Team at 800.554.1124, extension 101. Videolarm will return the repaired Product freight prepaid to Purchaser. Videolarm is not obligated to provide Purchaser with a substitute unit during the warranty period or at any time. After the applicable warranty period, Purchaser must pay all labor and/or parts charges.

The limited warranty stated in these product instructions is subject to all of the following terms and conditions:

- 1. NOTIFICATION OF CLAIMS: WARRANTY SERVICE:** If Purchaser believes that the Product is defective in material or workmanship, then written notice with an explanation of the claim shall be given promptly by Purchaser to Videolarm but all claims for warranty service must be made within the warranty period. If after investigation Videolarm determines that the reported problem was not covered by the warranty, Purchaser shall pay Videolarm for the cost of investigating the problem at its then prevailing per incident billable rate. No repair or replacement of any Product or part thereof shall extend the warranty period as to the entire Product. The specific warranty on the repaired part only shall be in effect for a period of ninety (90) days following the repair or replacement of that part or the remaining period of the Product parts warranty, whichever is greater.
 - 2. EXCLUSIVE REMEDY: ACCEPTANCE:** Purchaser's exclusive remedy and Videolarm's sole obligation is to supply (or pay for) all labor necessary to repair any Product found to be defective within the warranty period and to supply, at no extra charge, new or rebuilt replacements for defective parts.
 - 3. EXCEPTIONS TO LIMITED WARRANTY:** Videolarm shall have no liability or obligation to Purchaser with respect to any Product requiring service during the warranty period which is subjected to any of the following: abuse, improper use: negligence, accident, lightning damage or other acts of God (i.e., hurricanes, earthquakes), modification, failure of the end-user to follow the directions outlined in the product instructions, failure of the end-user to follow the maintenance procedures recommended by the International Security Industry Organization, written in product instructions, or recommended in the service manual for the Product. Furthermore, Videolarm shall have no liability where a schedule is specified for regular replacement or maintenance or cleaning of certain parts (based on usage) and the end-user has failed to follow such schedule; attempted repair by non-qualified personnel; operation of the Product outside of the published environmental and electrical parameters, or if such Product's original identification (trademark, serial number) markings have been defaced, altered, or removed. Videolarm excludes from warranty coverage Products sold AS IS and/or WITH ALL FAULTS and excludes used Products which have not been sold by Videolarm to the Purchaser. All software and accompanying documentation furnished with, or as part of the Product is furnished "AS IS" (i.e., without any warranty of any kind), except where expressly provided otherwise in any documentation or license agreement furnished with the Product.
 - 4. PROOF OF PURCHASE:** The Purchaser's dated bill of sale must be retained as evidence of the date of purchase and to establish warranty eligibility.
- DISCLAIMER OF WARRANTY EXCEPT FOR THE FOREGOING WARRANTIES, VIDEOLARM HEREBY DISCLAIMS AND EXCLUDES ALL OTHER WARRANTIES, EXPRESS OR IMPLIED, INCLUDING, BUT NOT LIMITED TO ANY AND/OR ALL IMPLIED WARRANTIES OF MERCHANTABILITY, FITNESS FOR A PARTICULAR PURPOSE AND/OR ANY WARRANTY WITH REGARD TO ANY CLAIM OF INFRINGEMENT THAT MAY BE PROVIDED IN SECTION 2-312(3) OF THE UNIFORM COMMERCIAL CODE AND/OR IN ANY OTHER COMPARABLE STATE STATUTE. VIDEOLARM HEREBY DISCLAIMS ANY REPRESENTATIONS OR WARRANTY THAT THE PRODUCT IS COMPATIBLE WITH ANY COMBINATION OF NON-VIDEOLARM PRODUCTS OR NON-VIDEOLARM RECOMMENDED PRODUCTS PURCHASER CHOOSES TO CONNECT TO PRODUCT.**
- LIMITATION OF LIABILITY THE LIABILITY OF VIDEOLARM, IF ANY, AND PURCHASER'S SOLE AND EXCLUSIVE REMEDY FOR DAMAGES FOR ANY CLAIM OF ANY KIND WHATSOEVER, REGARDLESS OF THE LEGAL THEORY AND WHETHER ARISING IN TORT OR CONTRACT, SHALL NOT BE GREATER THAN THE ACTUAL PURCHASE PRICE OF**

1

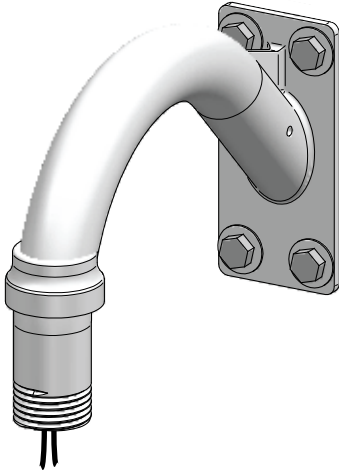

Securely mount bracket to wall. Pull wiring through bracket and position grommet as shown.

- Con seguridad soporte del montaje a emparedar. Tire del cableado a través del soporte y del ojal de la posición según lo demostrado.
- Solidement parenthèse de bâti à murer. Tirez le câblage par la parenthèse et le canon isolant de position comme montré.
- Sicher Einfassung Haltewinkel wall. Ziehen Sie Verdrahtung durch Haltewinkel und Position Gummimuffe, wie gezeigt.
- Firmemente suporte da montagem a wall. Puxe a fiação através do suporte e do ilhó da posição como mostrado.
- Saldamente staffa del supporto da wall. Tiri i collegamenti tramite la staffa ed il gommino di protezione di posizione come indicato.

2

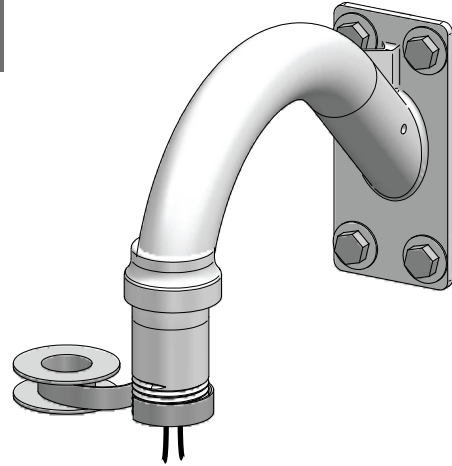

Wrap Teflon™ tape around the pipe threads to ensure a tight seal.

- La cinta del Teflon del abrigo alrededor de la pipa rosca para asegurar un sello apretado.
- La bande de teflon d'enveloppe autour de la pipe fileté pour assurer un joint serré.
- Verpackung Teflonklebeband um das Rohr verlegt, um eine feste Dichtung sicherzustellen.
- A fita adesiva do Teflon do envoltório em torno da tubulação enfia para assegurar um selo apertado.
- Il nastro del Teflon dell'involucro intorno al tubo filetta per accertare una guarnizione stretta.

3

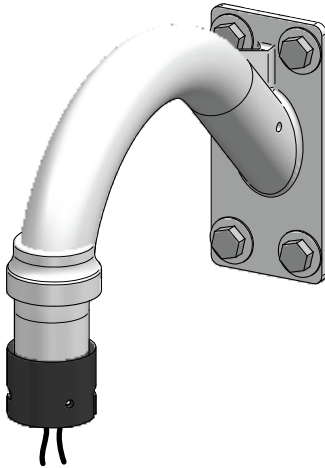

Screw the coupling onto the pipe threads until it is hand tight.

- Atornille el acoplador sobre los hilos de rosca de la pipa hasta que es mano firmemente.
- Vissez le couplage sur les fils de pipe jusqu'à ce que ce soit main fortement.
- Schrauben Sie die Koppelung auf die Rohrgewinde, bis es Hand fest ist.
- Parafuse o acoplamento nas linhas da tubulação até que esteja mão firmemente.
- Avviti l'accoppiamento sui filetti del tubo fino a che non sia fortemente mano.

4

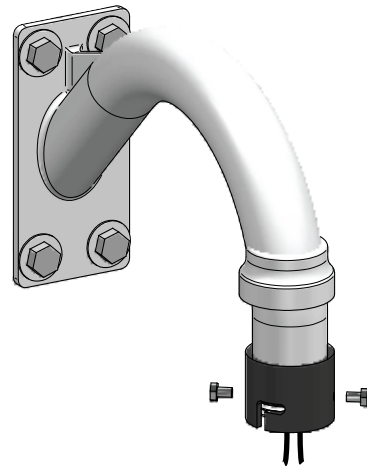

Screw the (2) bolts into the coupling.

- Atornille (2) los pernos en el acoplador.
- Vissez (2) les boulons dans l'accouplement.
- Schrauben Sie die (2) Schraubbolzen in die Koppelung.
- Parafuse (2) os parafusos no acoplamento.
- Avviti (2) i bulloni nell'accoppiamento.

5

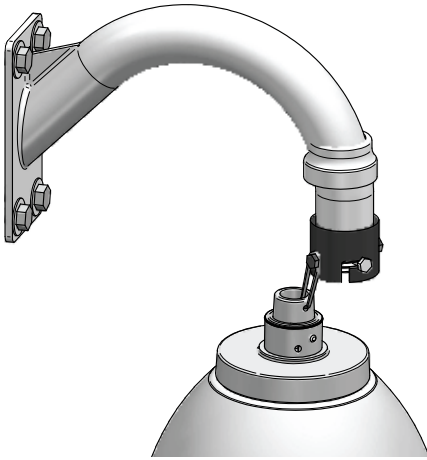

Loop the lanyard over the set screw to temporarily hold housing.

- Coloque el acollador sobre el tornillo de presión para celebrar temporalmente la cubierta.
- Faites une boucle la lanière au-dessus de la vis de réglage pour tenir temporairement le logement.
- Schlingen Sie die Abzuglinie über der Klemmschraube, um Gehäuse vorübergehend zu halten.
- Dê laços no colhedor sobre o parafuso de fixação para prender temporariamente a carcaça.
- Collegli la cordicella in circuito sopra la vite di arresto temporaneamente per tenere l'alloggiamento.

6

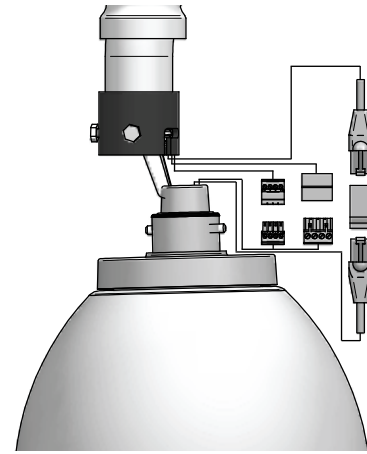

Make the appropriate wiring connections from the dome to the gooseneck.

- Haga las conexiones apropiadas del cableado de la bóveda al gooseneck.
- Établissez les rapports appropriés de câblage à partir du dôme au col de cygne.
- Stellen Sie die passenden Verdrahtung Beziehungen von der Haube zum gooseneck her.
- Faça as conexões apropriadas da fiação da abóbada ao gooseneck.
- Faccia i collegamenti adatti dei collegamenti dalla cupola al gooseneck.

7

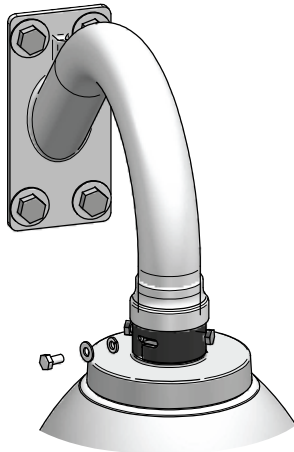

Undo the lanyard, pull housing up and twist secure with the locking bolt and washers.

- Deshaga el acollador, tire de contener para arriba y tuerza seguro con el perno y las arandelas de fijación.
- Défaites la lanière, tirez loger vers le haut et tordez bloqué avec le boulon et les rondelles de fermeture.
- Annulieren Sie die Abzuglinie, ziehen Sie oben unterbringen und verdrehen Sie sicheres mit dem verriegelnschraubbolzen und den Unterlegscheiben.
- Undo o colhedor, puxe abrigar acima e torça seguro com o parafuso e as arruelas travando.
- Undo la cordicella, tiri l'alloggio in su e torca sicuro con il bullone e le rondelle di bloccaggio.

8

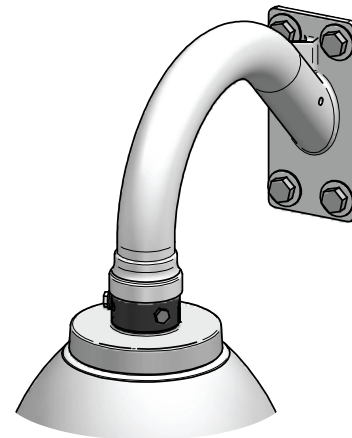

Slide the grommet down over the coupling to prevent water from entering and complete the assembly.

- Resbale el ojal abajo sobre el acoplador para evitar que el agua entre y para terminar a la asamblea.
- Glissez le canon isolant vers le bas au-dessus de l'accouplement pour empêcher l'eau d'entrer et pour accomplir l'assemblée.
- Schieben Sie die Gummimuffe unten über der Koppelung, um zu verhindern, daß Wasser und die Versammlung durchzuführen hereinkommt.
- Deslize o ilhó para baixo sobre o acoplamento para impedir que a água entre e para terminar o conjunto.
- Faccia scorrere il gommino di protezione giù sopra l'accoppiamento per impedire l'acqua entrare e per completare il complessivo.

Product Registration/Warranty

Thank you for choosing Videolarm. We value your patronage and are solely committed to providing you with only the highest quality products available with unmatched customer service levels that are second-to-none in the security industry.

Should a problem arise, rest assure that Videolarm stands behind its products by offering some of the most impressive warranty plans available: **3 Years** on all Housings, Poles, Power Supplies, and Accessories and **5 Years** on all camera systems (SView, QView, Warriors), and InfraRed Illuminators.



Register Your Products

Option 1: **Online** Option 2: **Mail-In**

Take a few moments and validate your purchase with our **Online Product Registration Form** at **www.videolarm.com/productregistration.jsp** or complete and mail-in the bottom portion of this flyer.

Register your recent Videolarm purchases and benefit from the following:

- Simple and Trouble-Free RMA process
- Added into customer database to receive product updates / news
- Eliminate the need to archive original purchase documents: Receipts, Purchase Orders, etc...



Cut at the dotted line

Main Contact Info

Place in envelope, affix stamp and mail to: Videolarm ATTN: Warranty
2525 Park Central Ave.
Decatur, GA 30035

First Name: _____ Last Name: _____
Professional Title: _____ Company: _____
Address 1: _____ Address 2: _____
City: _____ State / Province/Country: _____
Zip / Postal Code: _____ Phone Number: _____ E-mail Address: _____

Product Information

Please Circle One: Business Personal

Name & Location of Company / Store where Purchased: _____
(City, State, Country)
Videolarm Product ID _____ Product Description _____
Serial # _____
(Available only for Camera Systems, IR Illuminators, Wireless Devices)
PO# _____