

130 CONTROL SERIES

DART

CONTROLS

Instruction Manual

**Cycling and Reversing Variable Speed DC Control
with on Board Dynamic Braking**

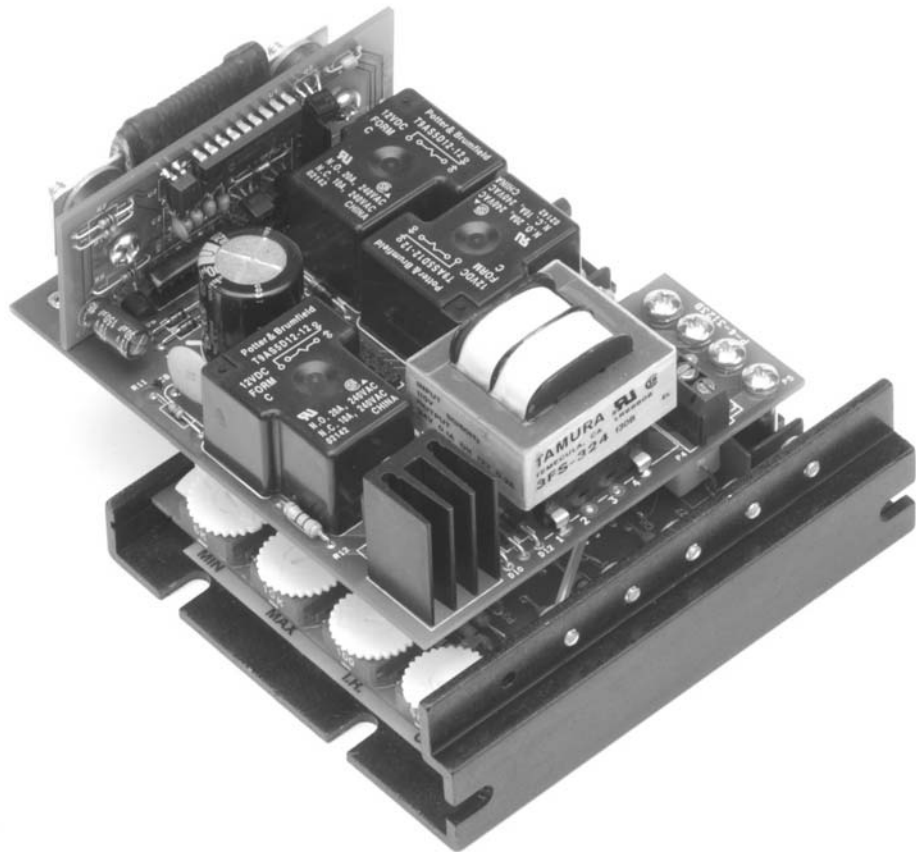

**P.O. Box 10
5000 W. 106th Street
Zionsville, Indiana 46077**

**Phone (317) 873-5211
Fax (317) 873-1105
www.dartcontrols.com**

Quick Jump

What models and options are available?

See page 4.

Looking for detailed specifications?

See page 11.

Want to get started fast?

See basic electrical hook-up details on page 6.

See mechanical installation details on page 3.

Need Help?

See troubleshooting on page 10.

Warranty

Dart Controls, Inc. (DCI) warrants its products to be free from defects in material and workmanship. The exclusive remedy for this warranty is DCI factory replacement of any part or parts of such product which shall within 12 months after delivery to the purchaser be returned to DCI factory with all transportation charges prepaid and which DCI determines to its satisfaction to be defective. This warranty shall not extend to defects in assembly by other than DCI or to any article which has been repaired or altered by other than DCI or to any article which DCI determines has been subjected to improper use. DCI assumes no responsibility for the design characteristics of any unit or its operation in any circuit or assembly. This warranty is in lieu of all other warranties, express or implied; all other liabilities or obligations on the part of DCI, including consequential damages, are hereby expressly excluded.

NOTE: Carefully check the control for shipping damage. Report any damage to the carrier immediately. Do not attempt to operate the drive if visible damage is evident to either the circuit or to the electronic components.

All information contained in this manual is intended to be correct, however information and data in this manual are subject to change without notice. DCI makes no warranty of any kind with regard to this information or data. Further, DCI is not responsible for any omissions or errors or consequential damage caused by the user of the product. DCI reserves the right to make manufacturing changes which may not be included in this manual.

WARNING

Improper installation or operation of this control may cause injury to personnel or control failure. The control must be installed in accordance with local, state, and national safety codes. Make certain that the power supply is disconnected before attempting to service or remove any components!!! If the power disconnect point is out of sight, lock it in disconnected position and tag to prevent unexpected application of power. Only a qualified electrician or service personnel should perform any electrical troubleshooting or maintenance. At no time should circuit continuity be checked by shorting terminals with a screwdriver or other metal device.

TABLE OF CONTENTS

INTRODUCTION	2
CONTROL FEATURES	2
130 SERIES HEATSINK AND MOUNTING	3
DIMENSIONS	3
MODEL SELECTION	4
WIRING PROCEDURE & FUSING	4
TERMINAL STRIP WIRING INSTRUCTIONS	4
130 HOOK-UP DIAGRAM	6
CONTROL START-UP	6
TRIMPOT ADJUSTMENT CHART & PROCEDURE	7
CONTROL MODIFICATIONS	9
SPEEDPOT KIT ASSEMBLY	9
OPTION DESCRIPTIONS	9
IN CASE OF DIFFICULTY	11
SPECIFICATIONS	11
TYPICAL MOTOR CURRENTS	11

INTRODUCTION

- The 130 series reversing speed control is designed to provide instant reversing, quick precise stopping or rapid cycling for a wide range of DC motor applications. The 130 series controls outperform other dynamic braking and reversing controls by utilizing Dart's unique zero speed detect and solid state assisted dynamic braking circuits. These circuits eliminate the contact arcing and failed braking problems associated with other reversing and dynamic braking controls. Dart's zero speed detect circuit also eliminates the motor problems associated with plug reversing a motor by not reapplying power to the motor until zero speed is obtained.
- The 130 series controls are also designed so that upon a power loss condition to the control or an E-stop condition, the control will drop into a dynamic brake condition to safely and quickly bring the motor to a stop and remain there until power is reapplied and a run condition is recognized.
- The 130 series variable speed control come in an extremely small package size and fits the industry standard footprint for both vertical and horizontal mounting patterns.
- The 130 series variable speed control is available in a range of 500mA through 10A_{dc} output at 120Vac or 240Vac input. This represent a Horsepower range of 1/50 through 1 at 90V_{dc} out or 1/25 through 2 at 180V_{dc} out.
- The control is designed for DC Permanent Magnet and Shunt Wound motors in the above horsepower ranges.
- Incoming AC voltage is converted to adjustable full wave rectified DC voltage to operate the DC motor. Also, a full wave field voltage is provided for shunt wound motors.
- The control incorporates transient voltage protection with adjustable current limit which fits into a compact package. It also features adjustable IR compensation along with adjustable minimum and maximum speeds settings.
- Available softstart option. (Consult factory for your OEM specific needs)
-  Listed, file #E78180

CONTROL FEATURES

- **MINIMUM SPEED** - Allows adjustment of the motor speed when the speedpot is set at minimum (CCW). This permits the user to eliminate "Deadband" on the main speed control, permitting zero calibration. Clockwise rotation of "MIN" trimpot increases speed.
- **MAX SPEED (Maximum Speed)** - Allows adjustment of the motor speed when the speedpot is set at maximum (CW). This permits the user to eliminate the top end "Deadband", which will provide full speed at maximum rotation. Rotation of the "MAX" trimpot in the clockwise direction increases the maximum motor speed.
- **I.R. COMP (Speed Regulation)** - This allows for adjustment of the circuitry that controls the speed regulation of the motor. The circuitry controls armature speed by changing the armature voltage to compensate for increased or decreased motor loading. Clockwise rotation of the "IR COMP" trimpot will increase compensation.

- **CUR. LIM. (Current Limit)** - Provides protection from excessive armature current by limiting the maximum armature current the control can provide. This enables adjustment of the maximum torque the motor can deliver. Torque adjustment (Cur. Lim.) is preset at 125% of rated motor torque (current) based on horsepower. Clockwise rotation of the "CUR. LIM." trimpot increases the torque (current) the control will provide.
- **BARRIER TERMINAL BLOCKS** - Allows for connection of AC lines, motor leads, motor field (if needed), speed potentiometer and Fwd-Brake-Rev inputs.
- **ONBOARD DYNAMIC BRAKE RESISTOR** - Consult factory for available remote mounting option of Brake resistor.
- **POWER LOSS BRAKE** - Upon a power loss to the control or an E-stop command, the control will drop into a dynamic brake condition to safely and quickly bring the motor to a stop and remain there until power is reapplied and a run condition is recognized.

130 SERIES HEATSINK AND MOUNTING DIMENSIONS

AUXILIARY HEATSINK -HS(125D)

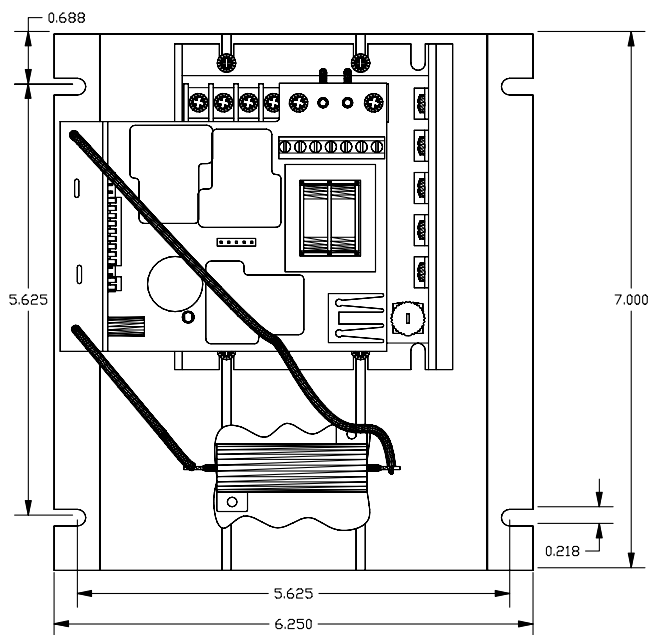

STANDARD HEATSINK

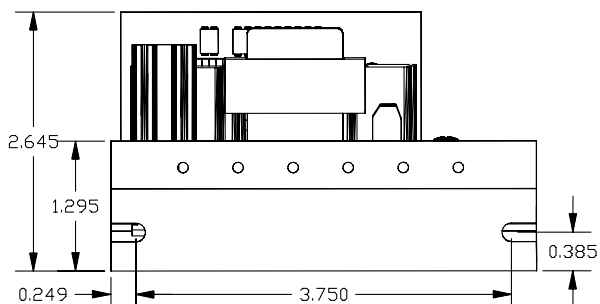
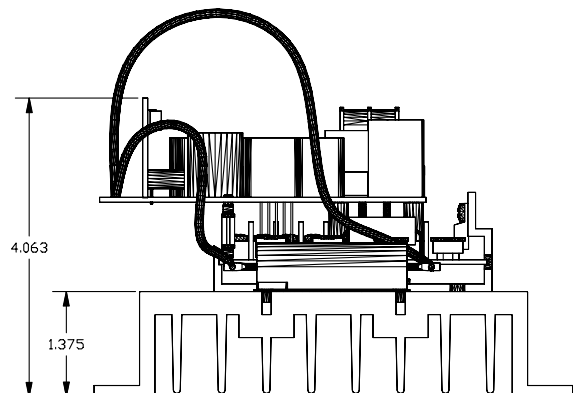
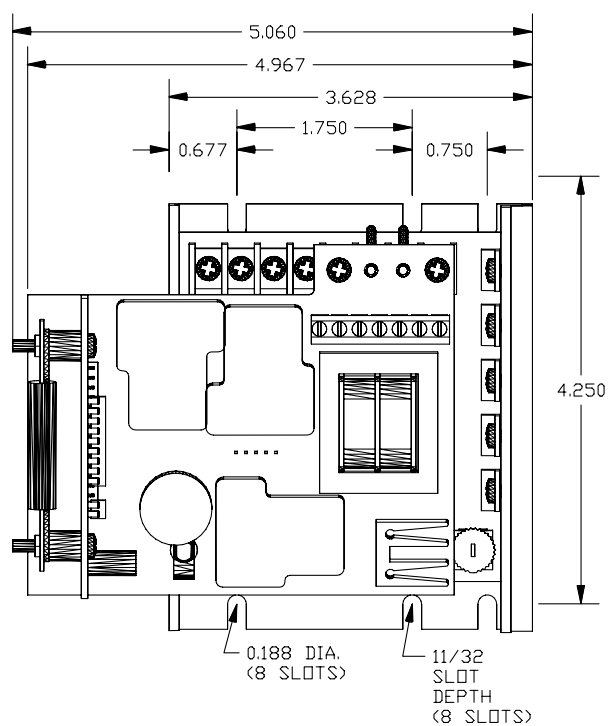

MODEL SELECTION

NOTE: * With suitable external heatsink (where 130 extrusion temperature does not exceed 70° C.), maximum rating for

INPUT VOLTAGE	OUTPUT VOLTAGE	MODEL NUMBER	OUTPUT* AMPS DC	HORSEPOWER
120 VAC	0-90 VDC	130LC12	1.2 ADC	1/50 – 1/8
120 VAC	0-90 VDC	130LC100	5.5 ADC*	1/8 – 1/2*
120 VAC	0-90 VDC	130HC12	1.2 ADC	1/50 – 1/8
120 VAC	0-90 VDC	130HC100	10 ADC*	1/8 – 1
240 VAC	0-180 VDC	132LC25	1.2 ADC	1/25 – 1/4
240 VAC	0-180 VDC	132LC200	5.5 ADC*	1/4 – 1*
240 VAC	0-180 VDC	132HC25	1.2 ADC	1/25 – 1/4
240 VAC	0-180 VDC	132HC200	10 ADC*	1/4 – 2

Output Amps can be increased to 10 ADC output at up to 1Hp at 90VDC or 2Hp at 180VDC.

WIRING PROCEDURE & FUSING

1. Size all wires which carry armature or line currents **AS SPECIFIED BY NATIONAL, STATE, AND/OR LOCAL CODES**. All other wires may be # 18 AWG or smaller as permitted by local code.
2. **Separate control wires** from the armature and AC lines when routed in conduit or in wire trays.
3. **Fusing** - The motor and control are protected against overloads by the current limit circuit and a customer installed fuse in the AC line. **THIS PROTECTION ALREADY MAY BE PROVIDED BY THE CUSTOMER WITH CIRCUIT BREAKERS OR FUSES IN BOTH MAIN LINES. IF NOT:**

FOR 120 VAC INPUT - fuse or breaker protection should be added by the customer inline with the Hot AC Line (see following chart).

FOR 240 VAC INPUT - fuse or breaker protection should be added by the customer inline with both Hot AC Lines (see following chart).

FUSING ADDED BY CUSTOMER (Bussman ABC or Little Fuse 314 Series ceramic fuses)

HORSEPOWER	120 VAC INPUT	240 VAC INPUT
1/50	2 AMP	-----
1/20	2 AMP	1 AMP
1/8	3 AMP	2 AMP
1/4	4 AMP	3 AMP
1/3	6 AMP	3 AMP
1/2	8 AMP	4 AMP
3/4	12 AMP	6 AMP
1.0	15 AMP	8 AMP
1.5	-----	12 AMP
2.0	-----	15 AMP

TERMINAL STRIP WIRING INSTRUCTIONS

Upper board terminal block connections (P4)

P4-1 (AC1 / L) – For single phase AC lines, (120VAC for US or 240VAC for Europe) connect the Hot side of your AC line to this terminal. For systems with two hot AC lines, (240VAC for US) connect either of the Hot AC lines to this terminal.

- P4-2 (AC2 / N) – For single phase AC lines, (120VAC for US or 240VAC for Europe) connect the Neutral side of your AC line to this terminal. For systems with two hot AC lines, (240VAC for US) connect either of the Hot AC lines to this terminal.
- P4-3 (A1) – For clockwise rotation of your motor in the Fwd. Direction, connect the Plus (+) Armature wire of the motor to this terminal.
- P4-4 (A2) – For counter-clockwise rotation of your motor in the Rev. direction, connect the Minus (-) Armature wire of the motor to this terminal.
- P4-5 (REV) – This is the reverse direction input terminal. When connected to the COM terminal, the control will release its brake circuit and accelerate to its set point in the reverse direction. When the connection to the COM terminal is opened the control will brake to zero speed. The connection to the COM terminal can be made via a mechanical switch, a relay contact, or an ungrounded solid state open collector type switch. Switching requirements are 5VDC at less than 1ma.
- P4-6 (FWD) – This is the forward direction input terminal. When connected to the COM terminal, the control will release its brake circuit and accelerate to its set point in the forward direction. When the connection to the COM terminal is opened the control will brake to zero speed. The connection to the COM terminal can be made via a mechanical switch, a relay contact, or an ungrounded solid state open collector type switch. Switching requirements are 5VDC at less than 1ma.
- P4-7 (COM) – This is the common terminal for the forward and reverse speed/dynamic brake commands. **This terminal should not be grounded or tied to any other terminal.**

Lower board terminal block connections (P1)

- P1-4 (-A/-F) – DO NOT use for Permanent Magnet Motor. This supplies -Field voltage for a SHUNT WOUND MOTOR (refer to field voltage table). For motors with dual voltage field (ie. 50/100V or 100/200V), make sure highest value is connected. Note: When connecting to this terminal, you will need to use a fork or ring connector placed directly under the screw head.
- P1-5 (+F) – DO NOT use for Permanent Magnet Motor. This supplies +Field voltage for a SHUNT WOUND MOTOR (refer to field voltage table). For motors with dual voltage field (ie. 50/100V or 100/200V), make sure highest value is connected.

FIELD VOLTAGE TABLE		
VAC INPUT	120	240
VDC FIELD	100	200

- P1-6 (Speedpot Hi) – Connects to high side (white wire) of Speedpot (CW end). This is an internal +12VDC. For start-stop applications, the connection between this terminal and Speedpot HI can be opened and closed by a SPST switch. **INPUT MUST NOT BE GROUNDED!**
- P1-7 (Speedpot Wiper) – Connects to wiper (red wire) of Speedpot (center lead). For Voltage Follower applications, this **INPUT MUST NOT BE GREATER THAN +12V MAXIMUM AND MUST NOT BE GROUNDED!**
- P1-8 (Speedpot Lo) – Connects to Low side (orange wire) of 5K Speedpot (CCW end). This input is raised and lowered by the MIN. trimpot (5K). Electronic speed input (voltage follower) may be referenced to Speedpot LO if the MIN trimpot adjustments are to be active. Otherwise, inputs may be referenced to -ARM, which will bypass the MIN trimpot. **INPUT MUST NOT BE GROUNDED!**

Warning:

1. Be sure the control housing is properly grounded.
2. For non-speedpot applications, the input connection to the LO, WIPER, and HI terminals must not be grounded! Serious control damage may result from a grounded input.

130 HOOK-UP DIAGRAM

Warning:

Do not attempt to perform Hi-pot test across AC lines with control in circuit.
This will result in immediate or long term damage to the control.

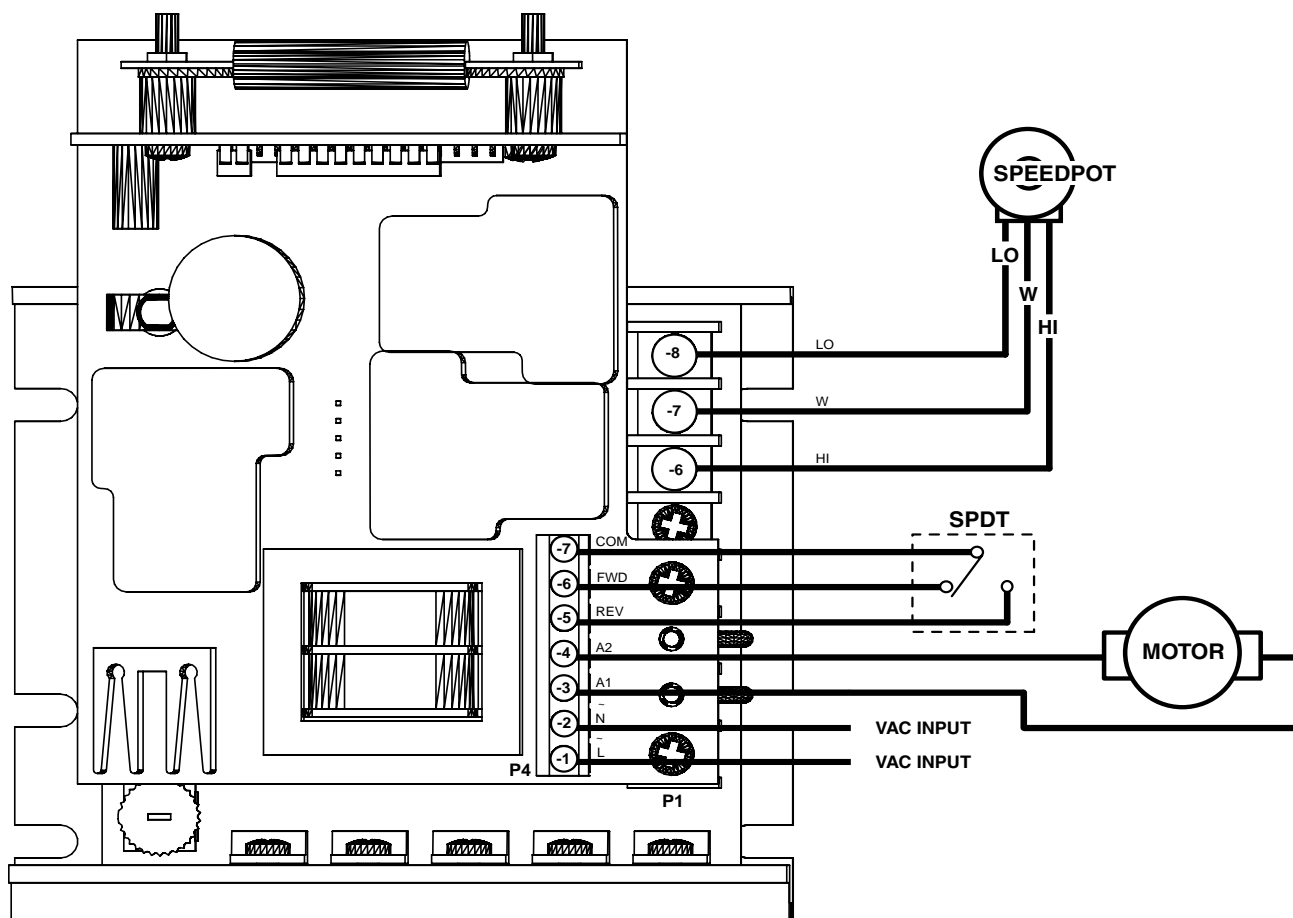

CONTROL START-UP

WARNING: ALL POWER MUST BE TURNED OFF BEFORE PROCEEDING!

1. Recheck all wiring. Accidental grounds to loose or pinched wires on the armature or speedpot wires may damage the control when power is applied.
2. Check to see that incoming service is of correct voltage.
3. Turn speedpot to zero (fully CCW).
4. Turn power on, close contact from COM(P4-7) to either FWD(P4-6) or REV(P4-5) and advance speedpot while observing motor rotation. **Power must be off before step 5 can be accomplished!**
5. If motor rotation is incorrect for the direction selected, turn power off at external disconnect and reverse the A1 and A2 motor connections.

6. Check for satisfactory operation throughout the speed range.
7. Open the FWD/REV connection to COM to verify motor brakes to zero speed.
8. If operation is satisfactory, no readjustments are needed.
9. If instability or surging is observed, or if maximum and minimum speed settings need further adjustments then see "TRIMPOT ADJUSTMENT CHART & PROCEDURE".
10. For other problems, consult page 10, "IN CASE OF DIFFICULTY".

TRIMPOT ADJUSTMENT CHART & PROCEDURE

Settings apply when using a 5K ohm master speedpot. This chart is used in conjunction with the adjustment procedure and is approximate.

	C.L.	I.R.	MAX	MIN	HP
130LC12 130HC12 120 VAC input; 0-90 VDC output					1/50
					1/20
					1/8
130LC100 130HC100 120 VAC input; 0-90 VDC output					1/8
					1/4
					1/3
					1/2
					3/4*
					1.0*

Operation of the control beyond ±10% of the normal line voltage could result in re-adjustment. These adjustments are permanent; periodic re-adjustment is normally not needed.

Settings apply when using a 5K ohm master speedpot. This chart is used in conjunction with the adjustment procedure and is approximate.

HP	C.L.	I.R.	MAX	MIN	
1/20					132LC25 132HC25 240 VAC input; 0-180 VDC output
1/8					
1/4					
1/4					132LC200 132HC200 240 VAC input; 0-180 VDC output
1/3					
1/2					
3/4*					
1.0*					
1.5*					
2.0*					

CONTROL MODIFICATIONS

TRIMPOT	FUNCTION	ADJUSTMENT
MIN.	Sets minimum motor speed when speedpot is set at zero. CW rotation will increase minimum motor speed.	<ol style="list-style-type: none"> 1. Select a direction and set Speedpot to zero (fully CCW). 2. Rotate MIN trimpot CW until motor starts to rotate 3. Slowly rotate MIN trimpot CCW until motor stops. NOTE: If motor rotation is desired, rotate MIN trimpot CW until desired MIN speed is reached
IR COMP	Provides a means of improving motor speed regulation. If a slowdown due to load change is of no concern, rotate this trimpot fully CCW.	<ol style="list-style-type: none"> 1. Select a direction and set Speedpot at 50%. 2. Observe motor speed at no load condition. 3. Apply full load to motor. 4. Turn IR COMP trimpot CW until you obtain the same motor speed as the no load condition.
MAX.	Sets maximum motor speed when speedpot is set at maximum (fully CW rotation). CW rotation of MAX trimpot increases maximum motor speed.	<ol style="list-style-type: none"> 1. TURN DRIVE POWER OFF!! 2. Connect a DC Voltmeter across A1 and A2. NOTE: Meter must not be grounded!! 3. Set meter voltage range if needed: (90 VDC for 120 VAC, 180VDC for 240 VAC). 4. Turn power on. Select a direction and set Speedpot at 100%. 5. Adjust the MAX trimpot to rated motor armature voltage as shown on meter. NOTE: A tachometer or strobe may be used in lieu of a meter. Follow above steps, except adjust MAX trimpot to rated motor base speed indicated by tachometer or strobe.
CUR.LIM.	Limits DC motor armature current (torque) to prevent damage to the motor or control. The current limit is set for the rated motor current. CW rotation of this trimpot increases the armature current (or torque produced).	<ol style="list-style-type: none"> 1. TURN DRIVE POWER OFF! 2. Connect a DC Ammeter between A1 on motor and A1 on the control. This is in series with the motor. NOTE: Meter must not be grounded!! 3. Turn power on. 4. Select a direction and set Speedpot at the 50% position. 5. Apply friction braking to motor shaft until motor stalls. 6. With motor stalled, set current at 125% of rated motor armature current by adjusting CUR. LIM . trimpot.

TWO SPEED OPERATION USING TWO 10K SPEEDPOTS

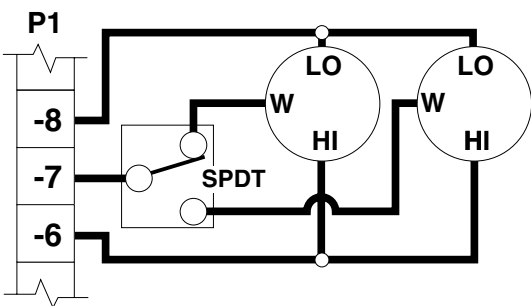

TWO SPEED OPERATION USING TWO 5K SPEEDPOTS

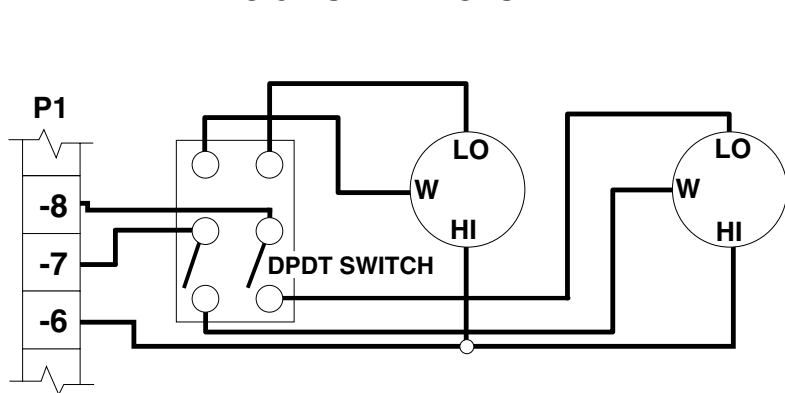

INHIBIT

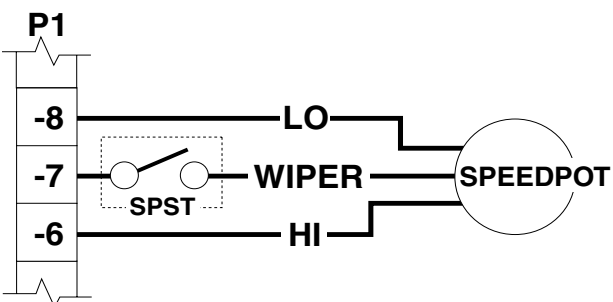

SPEEDPOT KIT ASSEMBLY

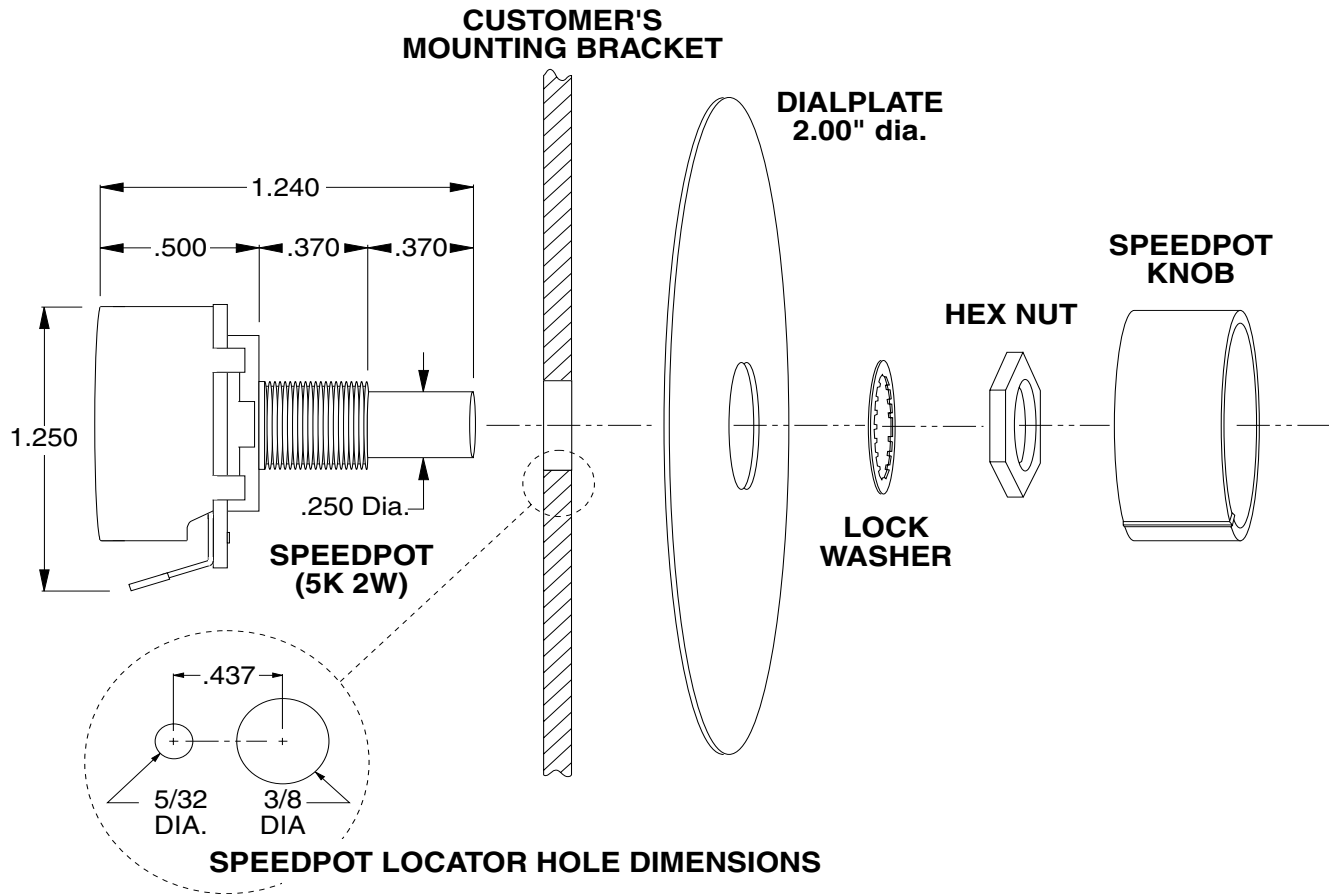

OPTION DESCRIPTIONS

-K option

Acceleration Time Ranges

Factory Installed

This option provides the Accel time shown below. The standard Accel time is 0.5 seconds.

ACCELERATION TIME----- 6
 seconds

USE STANDARD HOOK-UP

IN CASE OF DIFFICULTY

PROBLEM	POSSIBLE CAUSE(S)	CORRECTIVE ACTION(S)
Motor doesn't operate	<ul style="list-style-type: none"> - Blown Fuse or Breaker - Incorrect or no power source - Speedpot set at Zero - Worn motor brushes 	Replace Fuse or reset breaker Install proper service Adjust Speedpot CW to start Replace brushes
Armature output voltage cannot be adjusted, output is a constant DC level Motor stalls, or runs very slowly with speed control turned fully CW	<ul style="list-style-type: none"> - No motor or load connected - Speedpot low connection open - Low Voltage - Overload Condition - Worn motor brushes - MAX SPEED set incorrectly 	Check that motor or load is connected to armature terminals Check that speedpot low wire is connected Check that VAC is above 100VAC Reduce load or increase motor size and/or C.L. setting. Replace brushes See ADJUSTMENT PROCEDURE
Motor hunts	<ul style="list-style-type: none"> - Motor current less than 150Ma - Too much IR COMP - Motor is in current limit - Motor speed is above rated speed - Max set too high 	Motor current must be greater than 150mA D.C. See ADJUSTMENT PROCEDURE See ADJUSTMENT PROCEDURE Reduce Speed See ADJUSTMENT PROCEDURE
Repeated fuse blowing	<ul style="list-style-type: none"> - Low Voltage - Overload Condition - Worn motor brushes - Defective motor bearings - Defective electrical components 	Check that VAC is above 100VAC Reduce load Replace Replace Call Dart Distributor or Representative

If control still will not operate, consult your Dart Distributor or Representative.

SPECIFICATIONS

AC input voltage ----- ±10% of rated line voltage
 Acceleration ----- 0.5 seconds standard 125D
 Amps - DC output; (Models 130XX12 & 132XX25) ----- 500 mA to 1.2 ADC
 (Models 130LC100 & 132LC200) ----- 500 mA to 5.5 ADC*
 (Models 130HC100 & 132HC200) ----- 500 mA to 10 ADC
 Controller overload capacity ----- 200% for one minute
 Current limit trimpot range; (Models 130XX12 & 132XX25) ----- 0.3 to 3 ADC
 (Models 130XX100 & 132XX200) ----- 1 to 18 ADC
 Deceleration ----- 0.5 seconds (standard 125D)

Dimensions and weights:

LC MODELS	W	L	D	WEIGHT
ENGLISH	4.967"	4.250"	2.688"	1.08lb.
METRIC	126.16mm	107.95mm	68.27mm	489.87g
HC MODELS	W	L	D	WEIGHT
ENGLISH	6.250"	7.000"	4.063"	3.30lb.
METRIC	158.75mm	177.80mm	103.20mm	1496.80g

Drive service factor ----- 1.0
 Efficiency ----- 85% typical
 Input frequency ----- 50 or 60 Hertz
 Max. trimpot speed range ----- 60% to 110% of base speed
 Min. trimpot speed range ----- 0% to 30% of maximum speed
 Power devices ----- isolated case tab
 Shunt field voltage ----- 100VDC for 120VAC input; 200VDC for 240VAC input
 Shunt field current ----- 1 amp DC maximum
 Speed control ----- via 5Kohms .5W potentiometer or 0-10VDC isolated signal
 Speed range ----- 50:1
 Speed regulation ----- ±1% of base speed
 Temperature range ----- -10° to 45° C. ambient (15° to 115° F.)
 Terminal Block Torque Setting ----- 4.4 in. lb. Max or .5Nm
 Transient protection ----- G-Mov
 Trigger ----- opto-isolator
 Start/Brake cycle per minute (LC Models) ----- 3 per min**
 (HC Models) ----- 30 per min**

Approval -----



* With suitable external heatsink (where 130 extrusion temperature does not exceed 70° C.), maximum rating for output amps can be increased to 10 amps D.C.

** Cycles per minute are based on typical inertia type loads. Higher cycle per minute rates may be achieved with constant torque or low inertia type loads. Lower cycle rates may be required for very high inertia type loads.

TYPICAL MOTOR CURRENTS

Horsepower	1/50	1/20	1/8	1/4	1/3	1/2	3/4	1.0	1.5	2.0
Typical AC Amps (120VAC)	0.50	1.00	2.00	3.50	4.40	6.50	9.30	13.20	-----	-----
Typical Arm Amps (120VAC)	0.42	0.81	1.60	2.70	3.40	5.00	8.20	10.90	-----	-----
Typical AC Amps (240VAC)	-----	0.80	1.20	1.80	2.20	3.30	4.80	6.50	9.70	12.90
Typical Arm Amps (240VAC)	-----	0.40	0.60	1.40	1.70	2.50	3.70	5.00	8.20	11.60

- Notes -

- Notes -

REPAIR PROCEDURE

In the event that a Product manufactured by Dart Controls Incorporated (DCI) is in need of repair service, it should be shipped, freight paid, to: Dart Controls, Inc., 5000 W. 106th Street, Zionsville, IN. 46077, ATTN: Repair Department.

Those orders received from anyone without an existing account with DCI will need to specify if they will be paying COD or Credit Card (Master Card or Visa). This information is required before work can begin. If you have an account with Dart your order will be processed according to the terms listed on your account.

Completed repairs are returned with a Repair Report that states the problem with the control and the possible cause. Repair orders are returned via UPS Ground unless other arrangements are made. If you have further questions regarding repair procedures, contact your Dart Controls, Inc. at 317-733-2133 Ext.460.

YOUR MOTOR SPEED CONTROL SOLUTIONS PROVIDER



125D SERIES
AC INPUT - VARIABLE DC OUTPUT
1/50 HP through 1.0 HP



250G SERIES
AC INPUT - VARIABLE DC OUTPUT
1/50 HP through 2.0 HP



65 SERIES
DC INPUT - VARIABLE DC OUTPUT
CURRENT RATINGS OF 20, 40, AND
60 AMPS



700/COMMUTROL SERIES
DC BRUSHLESS
5 & 20 Amp for
12,24,& 36VDC Inputs



MDP SERIES
PROGRAMMABLE
CLOSED LOOP DC
SPEED CONTROL



DM SERIES
FIELD PROGRAMMABLE
DIGITAL TACHOMETER

Dart Controls, Inc. is a designer, manufacturer, and marketer of analog and digital electronic variable speed drives, controls, and accessories for AC, DC, and DC brushless motor applications.

Shown above is just a sampling of the expanded line of Dart controls that feature the latest in electronic technology and engineering. Products are manufactured in the U.S.A. at our Zionsville (Indianapolis,

Indiana) production and headquarters facility - with over 2,000,000 variable speed units in the field.

In addition to the standard off-the-shelf products, you can select from a wide variety of options to customize controls for your specific application. For further information and application assistance, contact your local Dart sales representative, stocking distributor, or Dart Controls, Inc.

Dart Controls, Inc.

Manufacturer of high quality DC and AC motor speed controls and accessories since 1963.

P.O. Box 10
5000 W. 106th Street
Zionsville, Indiana 46077
Phone: (317) 733-2133
Fax: (317) 873-1105