

**CHASSIS SECTION**

This service manual has been prepared to provide SUBARU service personnel with the necessary information and data for the correct maintenance and repair of SUBARU vehicles.

This manual includes the procedures for maintenance, disassembling, reassembling, inspection and adjustment of components and diagnostics for guidance of experienced mechanics.

Please peruse and utilize this manual fully to ensure complete repair work for satisfying our customers by keeping their vehicle in optimum condition. When replacement of parts during repair work is needed, be sure to use SUBARU genuine parts.

All information, illustration and specifications contained in this manual are based on the latest product information available at the time of publication approval.

FUJI HEAVY INDUSTRIES LTD.

**FRONT SUSPENSION** FS

**REAR SUSPENSION** RS

**WHEEL AND TIRE SYSTEM** WT

**DIFFERENTIALS** DI

**TRANSFER CASE** TC

**DRIVE SHAFT SYSTEM** DS

**ABS** ABS

**BRAKE** BR

**PARKING BRAKE** PB

**POWER ASSISTED SYSTEM  
(POWER STEERING)** PS

**ABS (DIAGNOSTICS)** ABS

# DIFFERENTIALS

# *DI*

---

	<b>Page</b>
1. General Description.....	2
2. Differential Gear Oil.....	22
3. Front Differential.....	24
4. Rear Differential for T-type.....	25
5. Rear Differential for VA-type.....	42
6. Rear Differential Front Oil Seal.....	59
7. Rear Differential Side Oil Seal.....	61
8. Rear Differential Member.....	66
9. General Diagnostic Table.....	67

# GENERAL DESCRIPTION

Differentials

## 1. General Description S303001

### A: SPECIFICATIONS S303001E49

Model	Non-Turbo		Turbo		
	MT	AT	Europe	Except Europe	
	T type	VA type		MT	AT
Rear differential type	T2	XH	HP (with oil temperature sensor)	CF	JP
Gear	Hypoid gear				
Gear ratio	4.111 (37/9)	4.444 (40/9)			
Oil capacity	0.8 L (0.8 US qt, 0.7 Imp qt)				
Rear differential gear oil	GL-5				

#### ● Identification

When replacing a rear differential assembly, select the correct one according to the following table.

#### CAUTION:

Using the different rear differential assembly causes the drive line and tires to “drag” or emit abnormal noise when AWD is selected.

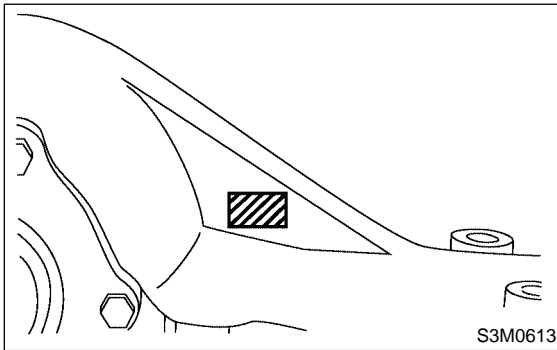

● **Rear differential gear oil**

Recommended oil

**CAUTION:**

**Each oil manufacturer has its base oil and additives. Thus, do not mix two or more brands.**

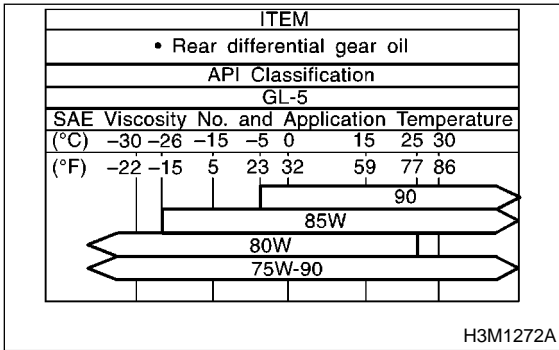

**1. SERVICE DATA** S303001E4901

Front and rear bearing preload at companion flange bolt hole N (kgf, lb)	New bearing	T-type	19.6 — 28.4 (2.0 — 2.9, 4.4 — 6.4)
		VA-type	12.7 — 32.4 (1.3 — 3.3, 2.9 — 7.3)
	Used bearing	T-type	8.34 — 16.67 (0.85 — 1.7, 1.87 — 3.75)
		VA-type	0.10 — 0.20 (0.0039 — 0.0079)
Side gear backlash mm (in)		VA-type	0.05 — 0.15 (0.0020 — 0.0059)
Side bearing standard width mm (in)			20.00 (0.7874)
Crown gear to drive pinion backlash mm (in)		T-type	0.10 — 0.20 (0.0039 — 0.0079)
		VA-type	0.10 — 0.15 (0.0039 — 0.0059)
Crown gear runout on its back surface mm (in)			Less than 0.05 (0.0020)

# GENERAL DESCRIPTION

Differentials

## 2. ADJUSTING PARTS S303001E4902

### ● VA-type

Item	Part No.	Length or thickness
Preload adjusting spacer	32288AA040	52.3 mm (2.059 in)
	32288AA050	52.5 mm (2.067 in)
	31454AA100	52.6 mm (2.071 in)
	32288AA060	52.7 mm (2.075 in)
	31454AA110	52.8 mm (2.079 in)
	32288AA070	52.9 mm (2.083 in)
	31454AA120	53.0 mm (2.087 in)
	32288AA080	53.1 mm (2.091 in)
	32288AA090	53.3 mm (2.098 in)
Preload adjusting washer	38336AA000	1.500 mm (0.0591 in)
	38336AA120	1.513 mm (0.0596 in)
	38336AA010	1.525 mm (0.0600 in)
	38336AA130	1.538 mm (0.0606 in)
	38336AA020	1.550 mm (0.0610 in)
	38336AA140	1.563 mm (0.0615 in)
	38336AA030	1.575 mm (0.0620 in)
	38336AA150	1.588 mm (0.0625 in)
	38336AA040	1.600 mm (0.0630 in)
	38336AA160	1.613 mm (0.0635 in)
	38336AA050	1.625 mm (0.0640 in)
	38336AA170	1.638 mm (0.0645 in)
	38336AA060	1.650 mm (0.0650 in)
	38336AA180	1.663 mm (0.0655 in)
	38336AA070	1.675 mm (0.0659 in)
	38336AA190	1.688 mm (0.0665 in)
	38336AA080	1.700 mm (0.0669 in)
	38336AA200	1.713 mm (0.0674 in)
	38336AA090	1.725 mm (0.0679 in)
	38336AA210	1.738 mm (0.0684 in)
38336AA100	1.750 mm (0.0689 in)	
38336AA220	1.763 mm (0.0694 in)	
38336AA110	1.775 mm (0.0699 in)	
Pinion height adjusting shim	32295AA200	0.150 mm (0.0059 in)
	32295AA210	0.175 mm (0.0069 in)
	32295AA220	0.200 mm (0.0079 in)
	32295AA230	0.225 mm (0.0089 in)
	32295AA240	0.250 mm (0.0098 in)
	32295AA250	0.275 mm (0.0108 in)
Side gear thrust washer	803135011	0.925 — 0.950 mm (0.0364 — 0.0374 in)
	803135012	0.950 — 0.975 mm (0.0374 — 0.0384 in)
	803135013	0.975 — 1.000 mm (0.0384 — 0.0394 in)
	803135014	1.000 — 1.025 mm (0.0394 — 0.0404 in)
	803135015	1.025 — 1.050 mm (0.0404 — 0.0413 in)

# GENERAL DESCRIPTION

Differentials

● T-type

Item	Part No.	Length or thickness
Preload adjusting spacer	383695201	56.2 mm (2.213 in)
	383695202	56.4 mm (2.220 in)
	383695203	56.6 mm (2.228 in)
	383695204	56.8 mm (2.236 in)
	383695205	57.0 mm (2.244 in)
	383695206	57.2 mm (2.252 in)
Preload adjusting washer	383705200	2.59 mm (0.1020 in)
	383715200	2.57 mm (0.1012 in)
	383725200	2.55 mm (0.1004 in)
	383735200	2.53 mm (0.0996 in)
	383745200	2.51 mm (0.0988 in)
	383755200	2.49 mm (0.0980 in)
	383765200	2.47 mm (0.0972 in)
	383775200	2.45 mm (0.0965 in)
	383785200	2.43 mm (0.0957 in)
	383795200	2.41 mm (0.0949 in)
	383805200	2.39 mm (0.0941 in)
	383815200	2.37 mm (0.0933 in)
	383825200	2.35 mm (0.0925 in)
	383835200	2.33 mm (0.0917 in)
383845200	2.31 mm (0.0909 in)	
Pinion height adjusting shim	383495200	3.09 mm (0.1217 in)
	383505200	3.12 mm (0.1228 in)
	383515200	3.15 mm (0.1240 in)
	383525200	3.18 mm (0.1252 in)
	383535200	3.21 mm (0.1264 in)
	383545200	3.24 mm (0.1276 in)
	383555200	3.27 mm (0.1287 in)
	383565200	3.30 mm (0.1299 in)
	383575200	3.33 mm (0.1311 in)
	383585200	3.36 mm (0.1323 in)
	383595200	3.39 mm (0.1335 in)
	383605200	3.42 mm (0.1346 in)
	383615200	3.45 mm (0.1358 in)
	383625200	3.48 mm (0.1370 in)
	383635200	3.51 mm (0.1382 in)
	383645200	3.54 mm (0.1394 in)
	383655200	3.57 mm (0.1406 in)
383665200	3.60 mm (0.1417 in)	
383675200	3.63 mm (0.1429 in)	
383685200	3.66 mm (0.1441 in)	
Side gear thrust washer	383445201	0.75 — 0.80 mm (0.0295 — 0.0315 in)
	383445202	0.80 — 0.85 mm (0.0315 — 0.0335 in)
	383445203	0.85 — 0.90 mm (0.0335 — 0.0354 in)
	383445204	0.90 — 0.95 mm (0.0354 — 0.0374 in)
	383445205	0.95 — 1.0 mm (0.0374 — 0.0394 in)

## GENERAL DESCRIPTION

Differentials

Item	Part No.	Length or thickness
Side bearing retainer shim	383475201	0.20 mm (0.0079 in)
	383475202	0.25 mm (0.0098 in)
	383475203	0.30 mm (0.0118 in)
	383475204	0.40 mm (0.0157 in)
	383475205	0.50 mm (0.0197 in)

## B: COMPONENT

S303001A05

### 1. REAR DIFFERENTIAL FOR T-TYPE WITHOUT LSD

S303001A0501

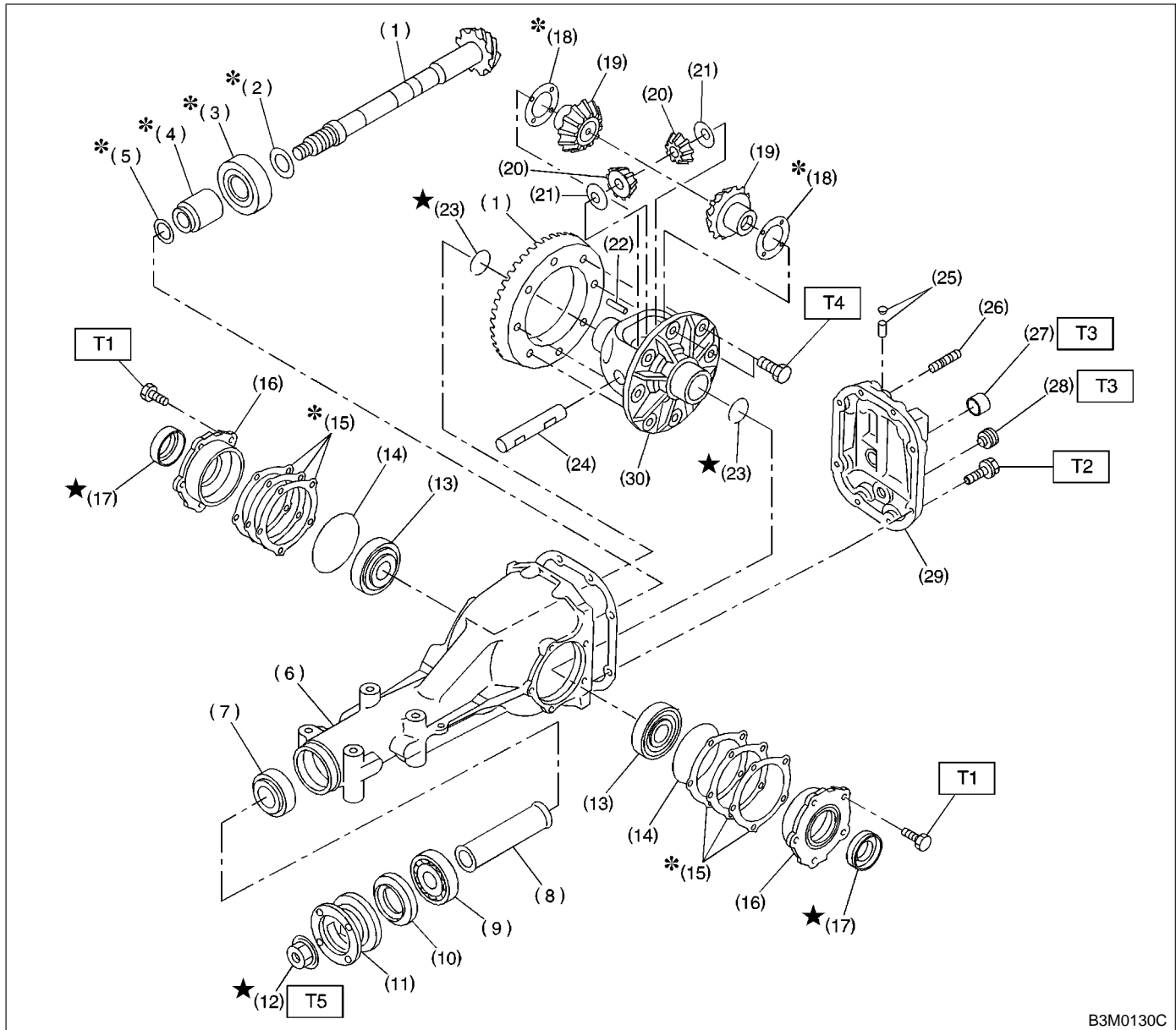

B3M0130C

- |                                      |                                 |                        |
|--------------------------------------|---------------------------------|------------------------|
| (1) Pinion crown gear set            | (13) Side bearing               | (26) Stud bolt         |
| (2) Pinion height adjusting washer   | (14) O-ring                     | (27) Oil filler plug   |
| (3) Rear bearing                     | (15) Side bearing retainer shim | (28) Oil drain plug    |
| (4) Bearing preload adjusting spacer | (16) Side bearing retainer      | (29) Rear cover        |
| (5) Bearing preload adjusting washer | (17) Side oil seal              | (30) Differential case |
| (6) Differential carrier             | (18) Side gear thrust washer    |                        |
| (7) Front bearing                    | (19) Side gear                  |                        |
| (8) Spacer                           | (20) Pinion mate gear           |                        |
| (9) Pilot bearing                    | (21) Pinion mate gear washer    |                        |
| (10) Front oil seal                  | (22) Pinion shaft lock pin      |                        |
| (11) Companion flange                | (23) Circlip                    |                        |
| (12) Self-locking nut                | (24) Pinion mate shaft          |                        |
|                                      | (25) Air breather cap           |                        |

**Tightening torque: N·m (kgf·m, ft·lb)**

**T1: 10.3 (1.05, 7.6)**

**T2: 29.4 (3.00, 21.7)**

**T3: 49.0 (5.0, 36.2)**

**T4: 103.0 (10.50, 75.9)**

**T5: 181.4 (18.50, 133.8)**



# GENERAL DESCRIPTION

Differentials

## 2. REAR DIFFERENTIAL FOR T-TYPE WITH LSD

S303001A0502

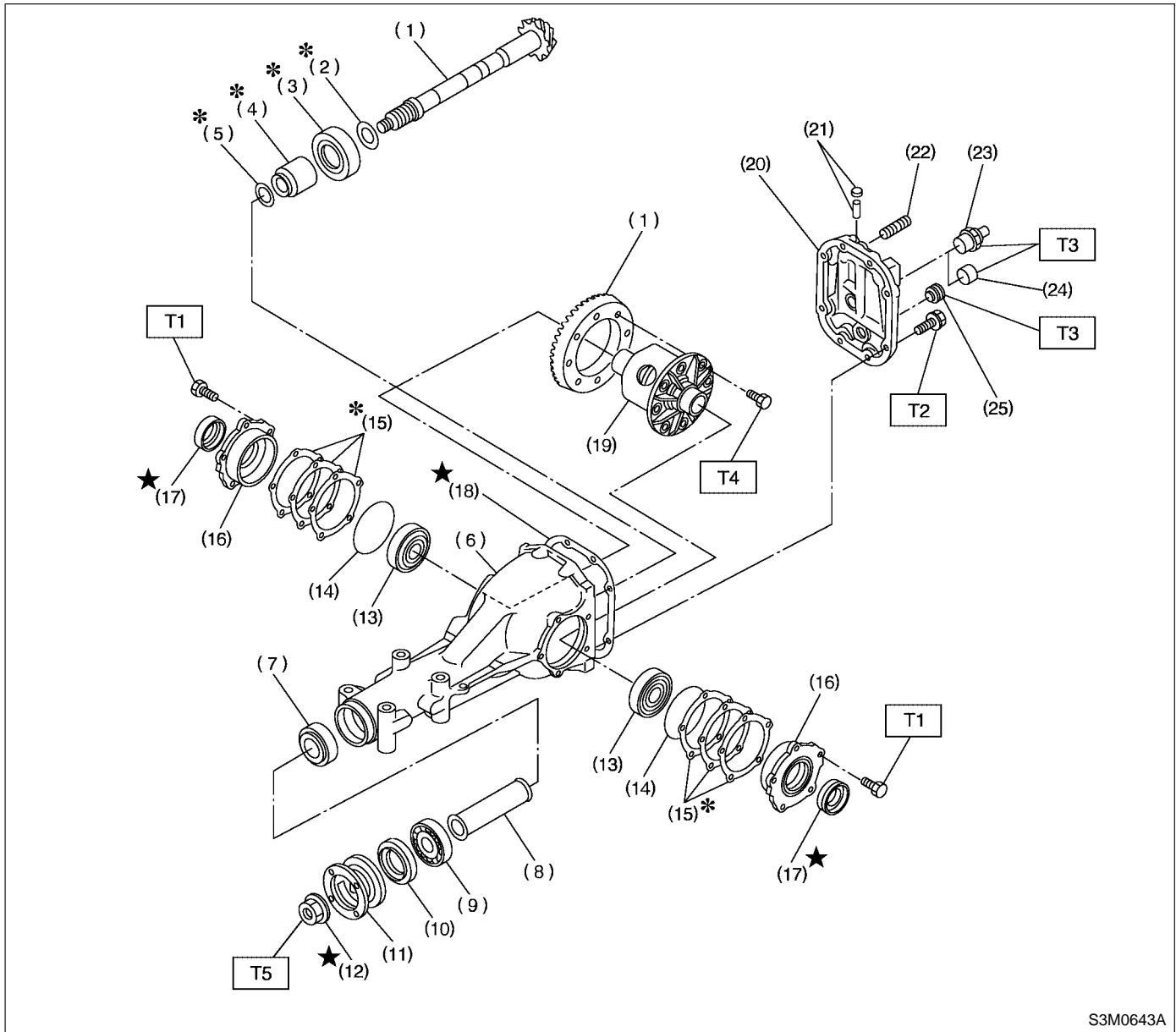

S3M0643A

- (1) Pinion crown gear set
- (2) Pinion height adjusting shim
- (3) Rear bearing
- (4) Bearing preload adjusting spacer
- (5) Bearing preload adjusting washer
- (6) Differential carrier
- (7) Front bearing
- (8) Collar
- (9) Pilot bearing
- (10) Front oil seal
- (11) Companion flange

- (12) Self-locking nut
- (13) Side bearing
- (14) O-ring
- (15) Side bearing retainer shim
- (16) Side bearing retainer
- (17) Side oil seal
- (18) Gasket
- (19) Differential case
- (20) Rear cover
- (21) Air breather cap
- (22) Stud bolt

- (23) Oil filler plug (With oil temperature sensor)
- (24) Oil filler plug (Without oil temperature sensor)
- (25) Oil drain plug

**Tightening torque: N·m (kgf·m, ft·lb)**

**T1: 10.3 (1.05, 7.6)**

**T2: 29 (3.0, 21.7)**

**T3: 49.0 (5.0, 36.2)**

**T4: 103 (10.5, 76)**

**T5: 181 (18.5, 134)**

## 3. REAR DIFFERENTIAL FOR VA-TYPE

S303001A0503

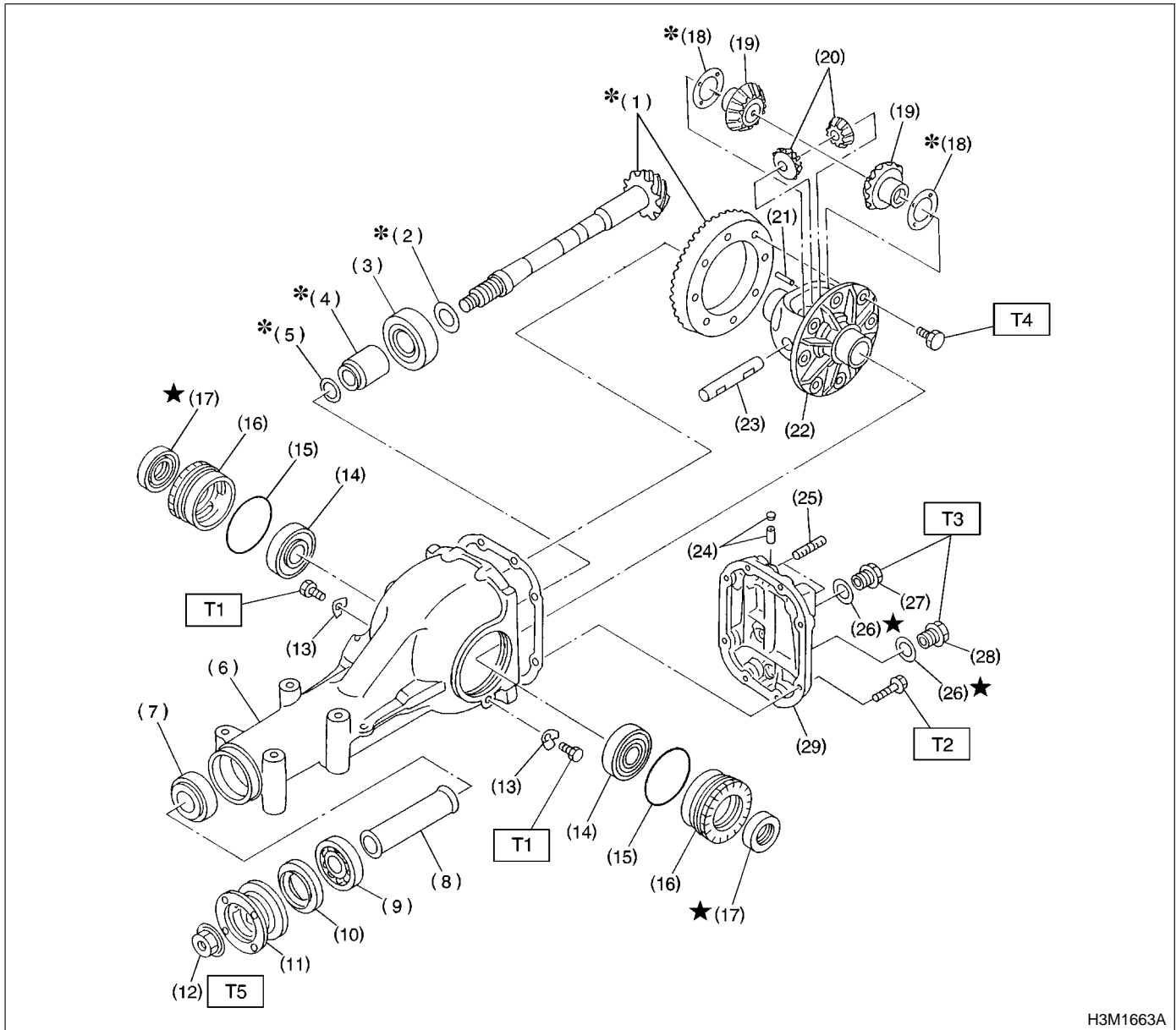

H3M1663A

- (1) Pinion crown gear set
- (2) Pinion height adjusting shim
- (3) Rear bearing
- (4) Bearing preload adjusting spacer
- (5) Bearing preload adjusting washer
- (6) Differential carrier
- (7) Front bearing
- (8) Collar
- (9) Pilot bearing
- (10) Front oil seal
- (11) Companion flange
- (12) Self-locking nut

- (13) Lock plate
- (14) Side bearing
- (15) O-ring
- (16) Axle shaft holder
- (17) Side oil seal
- (18) Side gear thrust washer
- (19) Side gear
- (20) Pinion mate gear
- (21) Pinion shaft lock pin
- (22) Differential case
- (23) Pinion mate shaft
- (24) Air breather cap
- (25) Stud bolt

- (26) Gasket
- (27) Oil filler plug
- (28) Oil drain plug
- (29) Rear cover

**Tightening torque: N·m (kgf·m, ft·lb)**

**T1: 25 (2.5, 18.1)**

**T2: 25 (2.5, 18.1)**

**T3: 34 (3.5, 25.3)**

**T4: 62 (6.3, 45.6)**

**T5: 188 (19.2, 139)**

# GENERAL DESCRIPTION

Differentials

## 4. REAR DIFFERENTIAL MOUNTING SYSTEM

S303001A0504

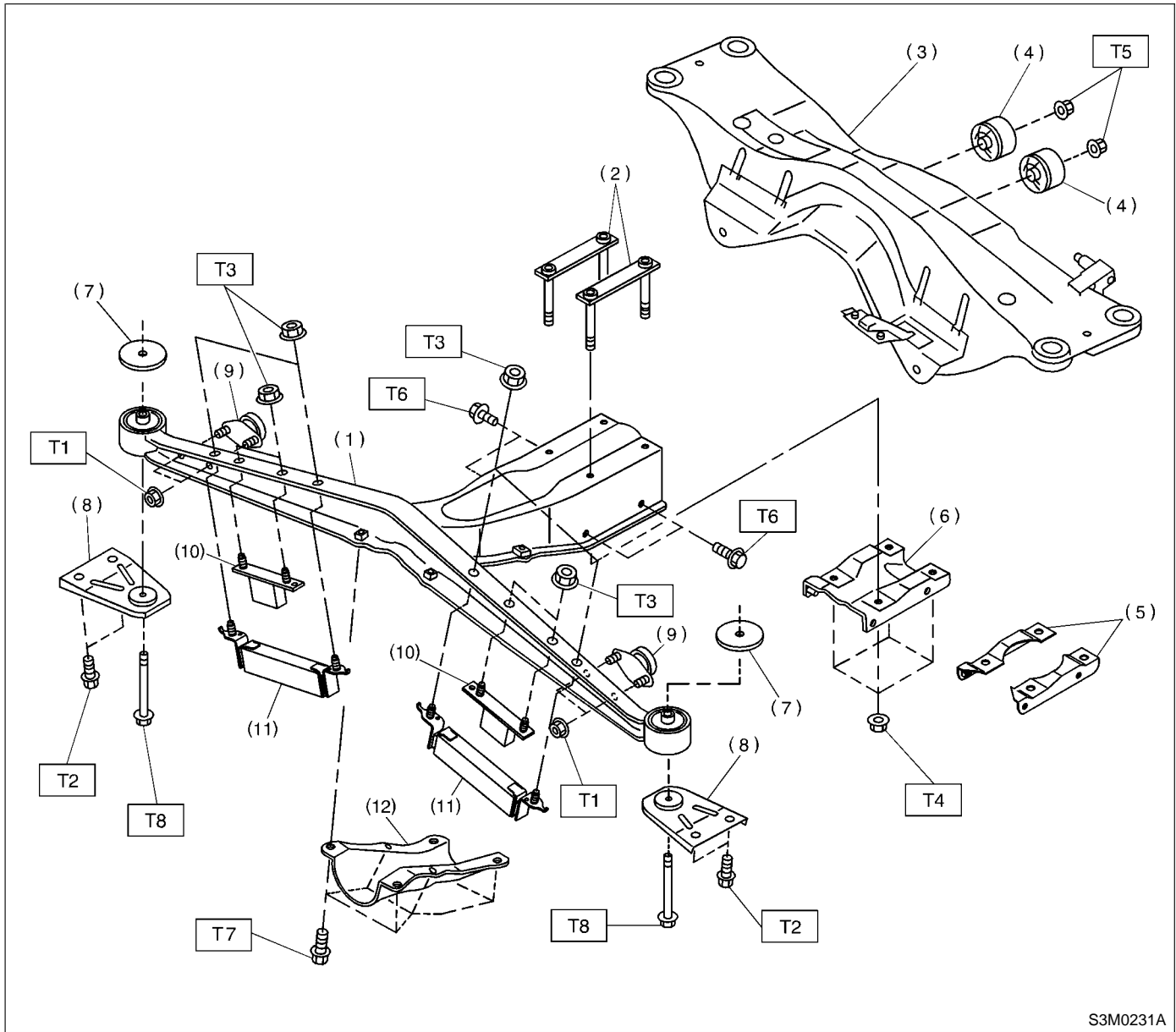

S3M0231A

- |  |   |
|--|---|
| (1) Differential front member                          | (8) Differential mount bracket          |
| (2) Plate  | (9) Dynamic damper A                    |
| (3) Crossmember  | (10) Mass damper (Turbo model)          |
| (4) Rear bushing                                       | (11) Dynamic damper B (Non-Turbo model) |
| (5) Differential mount lower bracket (Non-Turbo model) | (12) Differential mount front cover     |
| (6) Differential mount lower bracket (Turbo model)     |   |
| (7) Stopper  |   |

**Tightening torque: N·m (kgf·m, ft·lb)**

**T1: 20 (2.0, 14.5)**

**T2: 32 (3.3, 23.9)**

**T3: 40 (4.1, 30)**

**T4: 64 (6.5, 47.0)**

**T5: 69 (7.0, 50.6)**

**T6: 69 (7.0, 50.6)**

**T7: 88 (9.0, 65)**

**T8: 98 (10.0, 72)**

**C: CAUTION** S303001A03

- Wear working clothing, including a cap, protective goggles, and protective shoes during operation.
- Remove contamination including dirt and corrosion before removal, installation or disassembly.
- Keep the disassembled parts in order and protect them from dust or dirt.
- Before removal, installation or disassembly, be sure to clarify the failure. Avoid unnecessary removal, installation, disassembly, and replacement.
- Be careful not to burn your hands, because each part on the vehicle is hot after running.
- Use SUBARU genuine gear oil, grease etc. or the equivalent. Do not mix gear oil, grease etc. with that of another grade or from other manufacturers.
- Be sure to tighten fasteners including bolts and nuts to the specified torque.
- Place shop jacks or safety stands at the specified points.
- Apply gear oil onto sliding or revolution surfaces before installation.
- Before installing O-rings or snap rings, apply sufficient amount of gear oil to avoid damage and deformation.
- Before securing a part on a vise, place cushioning material such as wood blocks, aluminum plate, or shop cloth between the part and the vise.
- Avoid damaging the mating face of the case.

# GENERAL DESCRIPTION

Differentials

## D: PREPARATION TOOL S303001A17

### 1. SPECIAL TOOLS S303001A1701

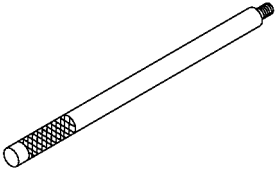
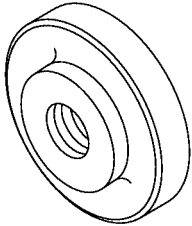
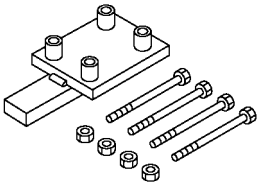
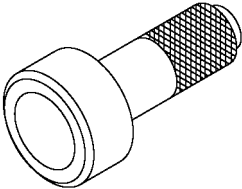
ILLUSTRATION	TOOL NUMBER	DESCRIPTION	REMARKS
 <p style="text-align: center;">B3M1893</p>	398477701	HANDLE	Used for installing front and rear bearing cone.
 <p style="text-align: center;">B3M1894</p>	398477702	DRIFT	Used press-fitting the bearing cone of differential carrier (rear).
 <p style="text-align: center;">B3M1895</p>	398217700	ATTACHEMENT SET	Stand for rear differential carrier disassembly and assembly.
 <p style="text-align: center;">B3M1896</p>	498447120	OIL SEAL INSTALLER	Used for installing front oil seal.

# GENERAL DESCRIPTION

Differentials

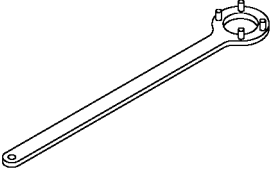
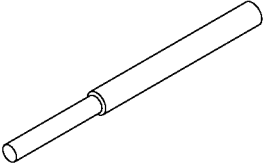
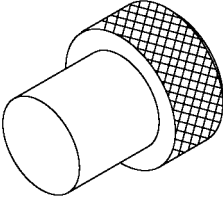
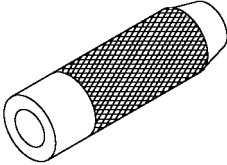
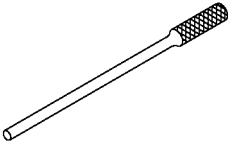
ILLUSTRATION	TOOL NUMBER	DESCRIPTION	REMARKS
 <p style="text-align: center;">B3M1897</p>	498427200	FLANGE WRENCH	Used for stopping rotation of companion flange when loosening and tightening self-lock nut.
 <p style="text-align: center;">B3M1898</p>	398467700	DRIFT	Used for removing pinion, pilot bearing and front bearing cone.
 <p style="text-align: center;">B3M1899</p>	399780104	WEIGHT	Used for installing front bearing cone, pilot bearing companion flange.
 <p style="text-align: center;">B3M1900</p>	899580100	INSTALLER	Used for press-fitting the front bearing cone, pilot bearing.
 <p style="text-align: center;">B3M1901</p>	899904100	STRAIGHT PIN REMOVER	Used for driving out differential pinion shaft lock pin.

# GENERAL DESCRIPTION

Differentials

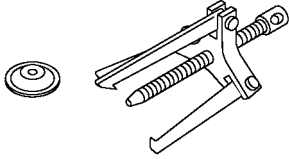
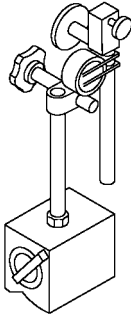
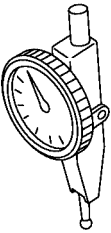
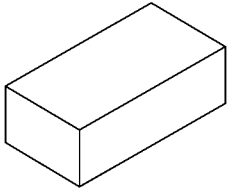
ILLUSTRATION	TOOL NUMBER	DESCRIPTION	REMARKS
 <p style="text-align: center;">B3M1930</p>	399703600	PULLEY ASSY	<ul style="list-style-type: none"> <li>● Used for removing companion flange.</li> </ul>
 <p style="text-align: center;">B3M1902</p>	498247001	MAGENT BASE	<ul style="list-style-type: none"> <li>● Used for measuring backlash between side gear and pinion, and hypoid gear..</li> <li>● Used with DIAL GAUGE (498247100).</li> </ul>
 <p style="text-align: center;">B3M1903</p>	498247100	DAIL GAUGE	<ul style="list-style-type: none"> <li>● Used measurng backlash between side gear and pinion, hypoid gear.</li> <li>● Used with MAGNET BASE (498247001).</li> </ul>
 <p style="text-align: center;">B3M1904</p>	398507704	BLOCK	Used for adjusting pinion height and preload.

# GENERAL DESCRIPTION

Differentials

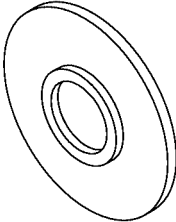
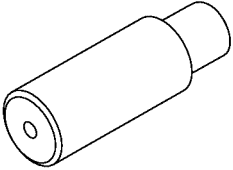
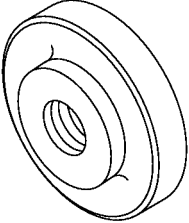
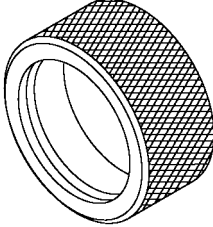
ILLUSTRATION	TOOL NUMBER	DESCRIPTION	REMARKS
 <p style="text-align: center;">B3M1905</p>	398177700	INSTALLER	<ul style="list-style-type: none"> <li>● Used for installing rear bearing cone.</li> <li>● For T-type.</li> </ul>
 <p style="text-align: center;">B3M1906</p>	398457700	ATTACHMENT	<ul style="list-style-type: none"> <li>● Used for removing side bearing retainer.</li> <li>● For T-type.</li> </ul>
 <p style="text-align: center;">B3M1907</p>	398477703	DRIFT2	<ul style="list-style-type: none"> <li>● Used for press-fitting the bearing race (rear) of differential carrier.</li> <li>● For T-type.</li> </ul>
 <p style="text-align: center;">B3M1908</p>	398437700	DRIFT	<ul style="list-style-type: none"> <li>● Used for installing said oil seal.</li> <li>● For T-type.</li> </ul>



# GENERAL DESCRIPTION

Differentials

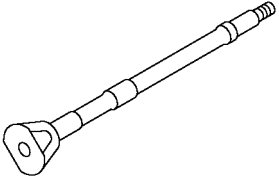
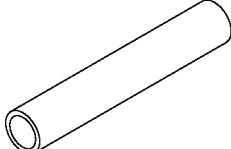
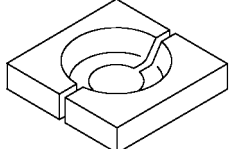
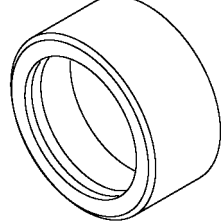
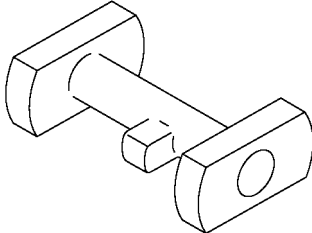
ILLUSTRATION	TOOL NUMBER	DESCRIPTION	REMARKS
 <p style="text-align: center;">B3M1909</p>	398507702	DUMMY SHAFT	<ul style="list-style-type: none"> <li>● Used for adjusting pinion height and preload.</li> <li>● For T-type.</li> </ul>
 <p style="text-align: center;">B3M1910</p>	398507703	DUMMY COLLAR	<ul style="list-style-type: none"> <li>● Used for adjusting pinion height and preload.</li> <li>● For T-type.</li> </ul>
 <p style="text-align: center;">B3M1911</p>	398517700	REPLACER	<ul style="list-style-type: none"> <li>● Used for removing rear bearing cone.</li> <li>● For T-type.</li> </ul>
 <p style="text-align: center;">B3M1912</p>	398487700	DRIFT	<ul style="list-style-type: none"> <li>● Used for press-fitting the side bearing cone.</li> <li>● For T-type.</li> </ul>
 <p style="text-align: center;">B3M1913</p>	398507701	GAUGE	<ul style="list-style-type: none"> <li>● Used for adjusting pinion height.</li> <li>● For T-type.</li> </ul>

# GENERAL DESCRIPTION

Differentials

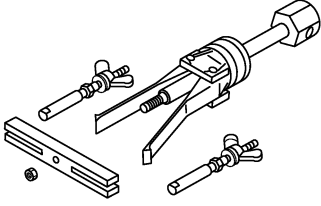
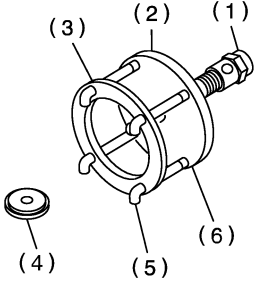
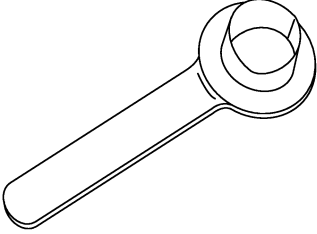
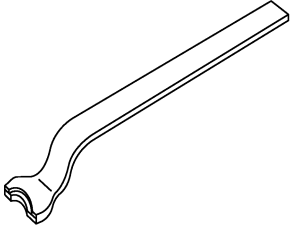
ILLUSTRATION	TOOL NUMBER	DESCRIPTION	REMARKS
 <p style="text-align: right;">B3M1914</p>	398527700	PULLER ASSY	<ul style="list-style-type: none"> <li>● Used for removing oil seal and side bearing cup.</li> <li>● For T-type.</li> </ul>
 <p style="text-align: right;">B3M1915A</p>	399527700	PULLER SET	<ul style="list-style-type: none"> <li>● Used for extracting side bearing cone.</li> <li>(1) BOLT (899521412)</li> <li>(2) PULLER (399527702)</li> <li>(3) HOLDER (399527703)</li> <li>(4) ADAPTER (398497701)</li> <li>(5) BOLT (899520107)</li> <li>(6) NUT (021008000)</li> <li>● For T-type.</li> </ul>
 <p style="text-align: right;">B3M1917</p>	28099PA090	OIL SEAL PROTECTOR	<ul style="list-style-type: none"> <li>● Used for installing rear drive shaft into rear differential.</li> <li>● For protecting oil seal.</li> <li>● For T-type.</li> </ul>
 <p style="text-align: right;">B3M1919</p>	28099PA100	DRIVE SHAFT REMOVER	<ul style="list-style-type: none"> <li>● Used for removing rear drive shaft from rear differential.</li> <li>● For T-type.</li> </ul>

# GENERAL DESCRIPTION

## Differentials

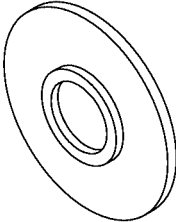
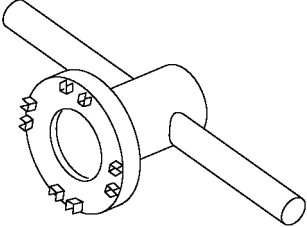
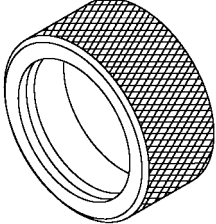
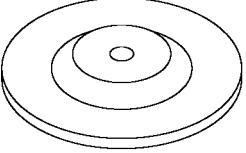
ILLUSTRATION	TOOL NUMBER	DESCRIPTION	REMARKS
 <p style="text-align: right; margin-right: 10px;">B3M1920</p>	498175500	INSTALLER	<ul style="list-style-type: none"> <li>● Used for installing rear bearing cone.</li> <li>● For VA-type.</li> </ul>
 <p style="text-align: right; margin-right: 10px;">B3M1921</p>	399780111	WRENCH ASSY	<ul style="list-style-type: none"> <li>● Used for removing and installing side oil seal holder.</li> <li>● For VA-type.</li> </ul>
 <p style="text-align: right; margin-right: 10px;">B3M1922</p>	498447100	INSTALLER	<ul style="list-style-type: none"> <li>● Used for installing oil seal.</li> <li>● For VA-type.</li> </ul>
 <p style="text-align: right; margin-right: 10px;">B3M1923</p>	399520105	SEAT	<ul style="list-style-type: none"> <li>● Used for removing side bearing cone.</li> <li>● Used with PULLER SET (899524100).</li> <li>● For VA-type.</li> </ul>

# GENERAL DESCRIPTION

Differentials

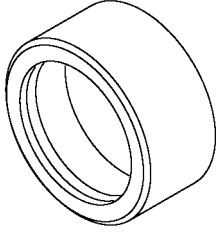
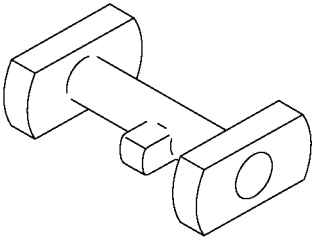
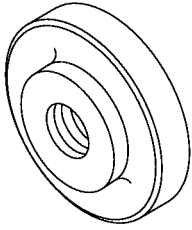
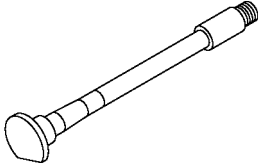
ILLUSTRATION	TOOL NUMBER	DESCRIPTION	REMARKS
 <p style="text-align: center;">B3M1924</p>	498485400	DRIFT	<ul style="list-style-type: none"> <li>● Used for installing side bearing cone.</li> <li>● For VA-type.</li> </ul>
 <p style="text-align: center;">B3M1925</p>	498505501	GAUGE	<ul style="list-style-type: none"> <li>● Used for adjusting pinion height.</li> <li>● For VA-type.</li> </ul>
 <p style="text-align: center;">B3M1926</p>	498447110	BEARING OUTER RACE DRIFT	<ul style="list-style-type: none"> <li>● Used for press-fitting the bearing race (front) of differential carrier.</li> <li>● For VA-type.</li> </ul>
 <p style="text-align: center;">B3M1927</p>	498447150	DUMMY SHAFT	<ul style="list-style-type: none"> <li>● Used for adjusting pinion height and Pre-load.</li> <li>● For VA-type.</li> </ul>

# GENERAL DESCRIPTION

Differentials

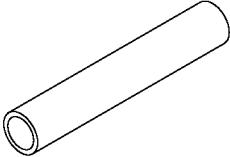
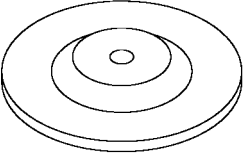
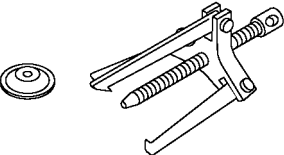
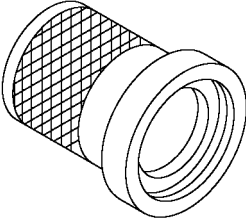
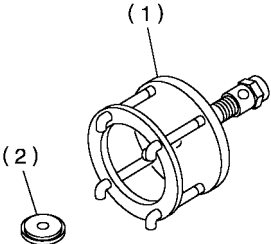
ILLUSTRATION	TOOL NUMBER	DESCRIPTION	REMARKS
 <p style="text-align: right;">B3M1928</p>	32285AA000	DUMMY COLLAR	<ul style="list-style-type: none"> <li>● Used for adjusting pinion height and Pre-load.</li> <li>● For VA-type.</li> </ul>
 <p style="text-align: right;">B3M1929</p>	499705404	SEAT	<ul style="list-style-type: none"> <li>● Used for removing side bearing race.</li> <li>● Used with PULLEY ASSY (499705401).</li> <li>● For VA-type.</li> </ul>
 <p style="text-align: right;">B3M1930</p>	499705401	PULLEY ASSY	<ul style="list-style-type: none"> <li>● Used for removing side bearing race.</li> <li>● Used with SEAT (499705404).</li> <li>● For VA-type.</li> </ul>
 <p style="text-align: right;">B3M1931</p>	899874100	INSTALLER	<ul style="list-style-type: none"> <li>● Used for installing companion flange.</li> <li>● For VA-type.</li> </ul>
 <p style="text-align: right;">B3M1932A</p>	899524100	DIFFERENTIAL BEARING PULLER SET	<ul style="list-style-type: none"> <li>● Used for removing side bearing cone of differential.</li> <li>● For VA-type.</li> <li>(1) Puller</li> <li>(2) Cap</li> <li>● Used with SEAT (399520105)</li> </ul>

# GENERAL DESCRIPTION

Differentials

## 2. GENERAL PURPOSE TOOLS S301001A1702

TOOL NAME	REMERKS
Transmission Jack	Used for assembly/disassembly of rear differential.
Puller	Used for removal of side bearing retainer. (T-type)
Thickness Gauge	Used for measuring clearance.
Tire Lever	Used for removal of rear drive shaft. (VA-type)

# DIFFERENTIAL GEAR OIL

Differentials

## 2. Differential Gear Oil S303150

### A: INSPECTION S303150A10

- 1) Set vehicle on a lift.
- 2) Disconnect ground terminal from battery.
- 3) Lift vehicle.
- 4) Disconnect oil temperature sensor connector (Turbo model for Europe).

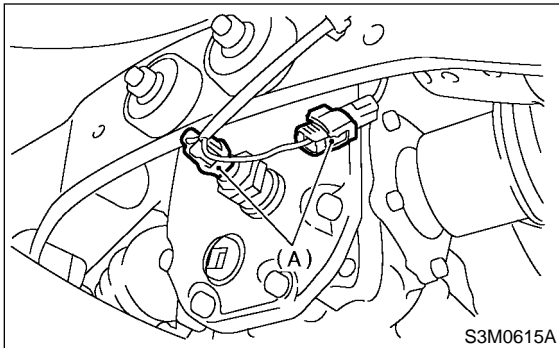

(A) Connector

- 5) Take out filler plug, and replace gear oil if it is contaminated or deteriorated. <Ref. to DI-22 REPLACEMENT, Differential Gear Oil.>
- 6) Check gear oil level is up to the bottom part of filler bolt. If the level is low, refill up to the bottom of filler bolt.

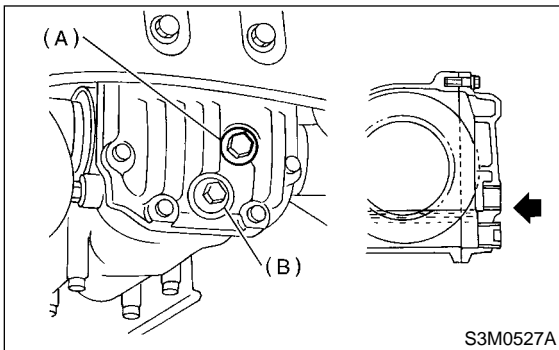

(A) Filler plug  
(B) Drain plug

### B: REPLACEMENT S303150A20

- 1) Disconnect ground terminal from battery.
- 2) Jack-up vehicle and support it with sturdy racks.
- 3) Disconnect oil temperature sensor connector (Turbo model for Europe).

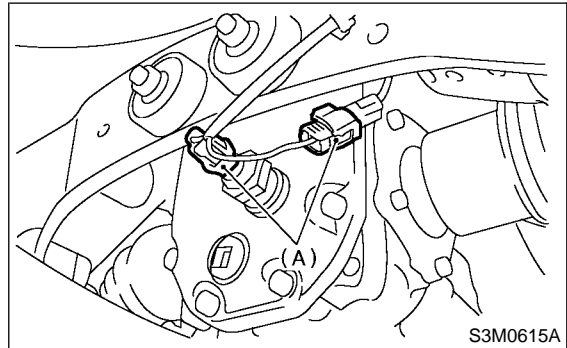

(A) Connector

- 4) Remove the oil drain plug and filler plug, and drain the gear oil.

#### CAUTION:

**Be careful not to burn your hands, because gear oil becomes extremely hot after running.**

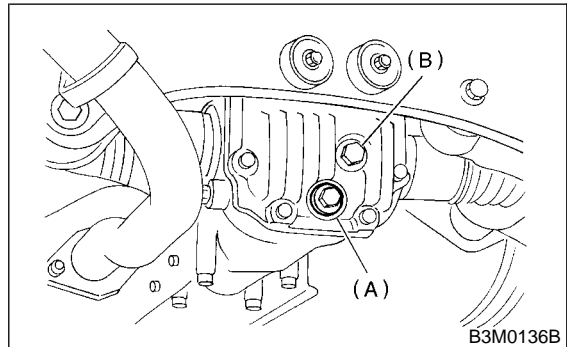

(A) Filler plug  
(B) Drain plug

- 5) Tighten oil drain plug.

#### CAUTION:

- Apply fluid packing to drain plug in T-type.
- VA-type uses a new aluminum gasket.

#### Fluid packing:

**THREE BOND 1105 or equivalent**

#### Tightening torque:

##### T-type;

**49.0 N·m (5.0 kgf-m, 36.2 ft-lb)**

##### VA-type;

**34 N·m (3.5 kgf-m, 25.3 ft-lb)**

6) Fill differential carrier with gear oil to the upper plug level.

**CAUTION:**

Carefully refill oil while watching the level.  
Excess or insufficient oil must be avoided.

**Oil capacity:**

**0.8 l (0.8 US qt, 0.7 Imp qt)**

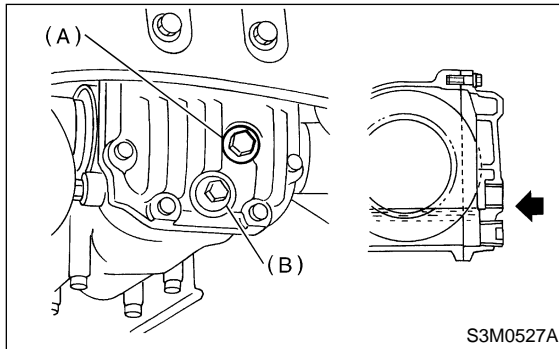

- (A) Filler plug  
(B) Drain plug

7) Install filler plug.

**CAUTION:**

- Apply fluid packing to drain plug in T-type.
- VA-type uses a new aluminum gasket.

**Fluid packing:**

**THREE BOND 1105 or equivalent**

**Tightening torque:****T-type;**

**49.0 N·m (5.0 kgf·m, 36.2 ft·lb)**

**VA-type;**

**34 N·m (3.5 kgf·m, 25.3 ft·lb)**

8) Connect oil temperature sensor connector.



## 3. Front Differential S303152

### A: NOTE S303152A15

#### 1. AT MODEL S303152A1501

Refer to AUTOMATIC TRANSMISSION in separate publication "AUTOMATIC TRANSMISSION for Front Differential. (Pub No. G0853ZE)

#### 2. MT MODEL S303152A1502

For front differential of manual transmission, refer to "MT" section. <Ref. to MT-92, Front Differential Assembly.>

## 4. Rear Differential for T-type

S303145

### A: REMOVAL S303145A18

- 1) Set vehicle on a lift.
- 2) Disconnect ground terminal from battery.
- 3) Move select lever or gear shift lever to "N".
- 4) Release the parking brake.
- 5) Loosen wheel nuts.
- 6) Jack-up vehicle and support it with sturdy racks.
- 7) Remove wheels.
- 8) Remove rear exhaust pipe and muffler.

Non-turbo model with OBD:

<Ref. to EX(SOHC)-9, REMOVAL, Rear Exhaust Pipe.> and <Ref. to EX(SOHC)-11, REMOVAL, Muffler.>

Non-turbo model without OBD:

<Ref. to EX(SOHCw/oOBD)-10, REMOVAL, Rear Exhaust Pipe.> and <Ref. to EX(SOHCw/oOBD)-12, REMOVAL, Muffler.>

Turbo model:

<Ref. to EX(DOHC TURBO)-14, REMOVAL, Rear Exhaust Pipe.> and <Ref. to EX(DOHC TURBO)-15, REMOVAL, Muffler.>

- 9) Remove front exhaust cover. (Non-Turbo model)

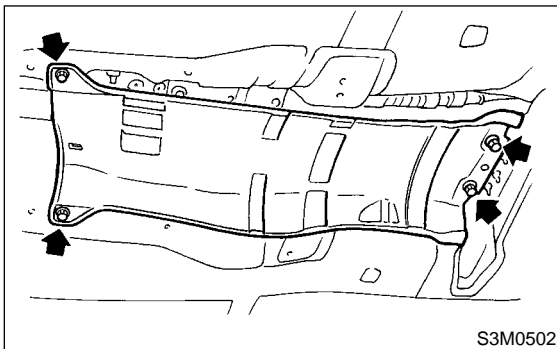

- 10) Remove front cover of rear differential mount.

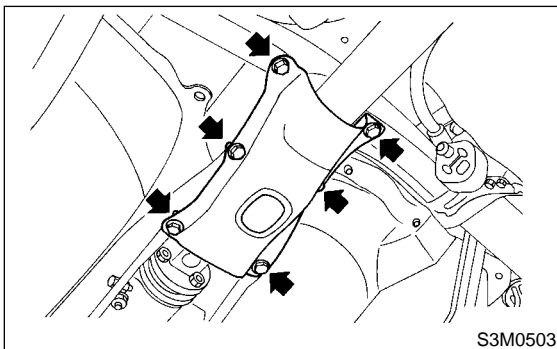

- 11) Remove propeller shaft.  
<Ref. to DS-14, REMOVAL, Propeller Shaft.>

- 12) Remove heat sealed cover.

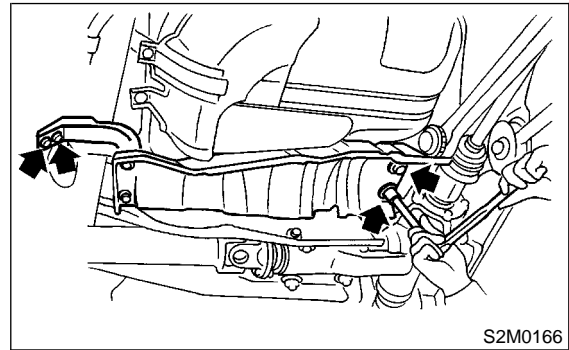

- 13) Remove clamps and bracket of parking brake cable.

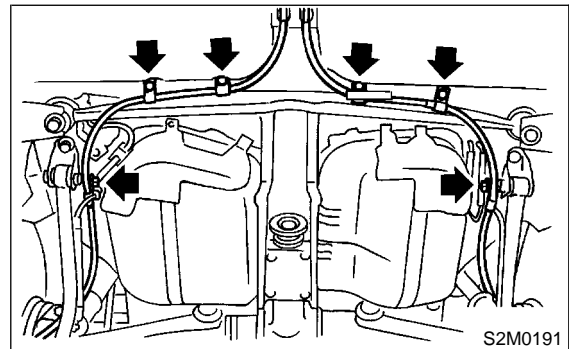

- 14) Disconnect connector from oil temperature sensor. (Turbo model for Europe)

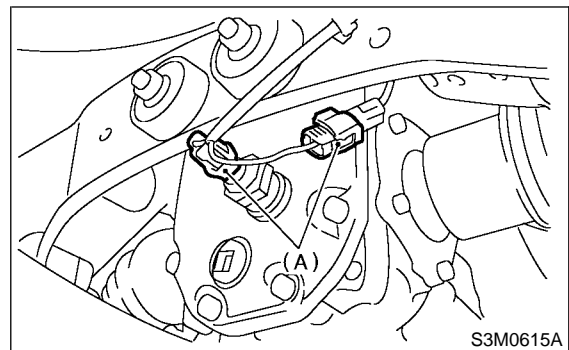

(A) Connector

# REAR DIFFERENTIAL FOR T-TYPE

## Differentials

15) Remove DOJ of rear drive shaft from rear differential using ST. <Ref. to DS-38, REMOVAL, Rear Drive Shaft.>

ST 28099PA100 DRIVE SHAFT REMOVER

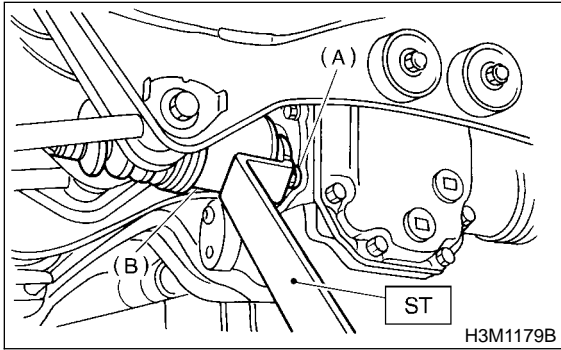

- (A) Bolt
- (B) DOJ

16) Secure rear drive shaft to rear crossmember using wire.

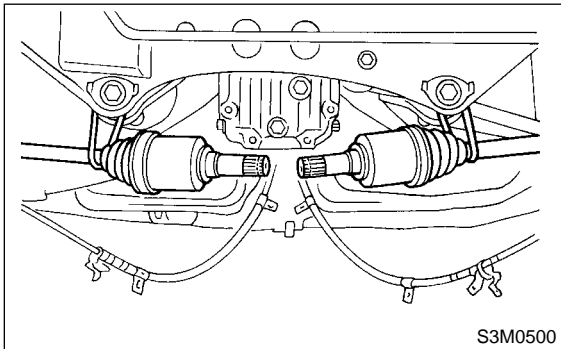

17) Remove lower differential bracket.

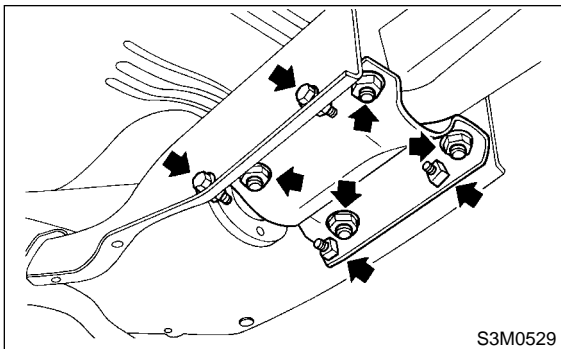

18) Support rear differential with transmission jack.

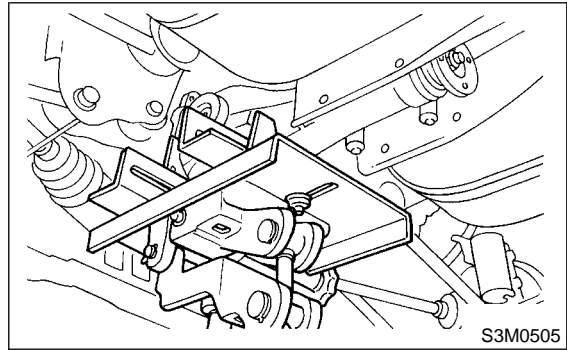

19) Remove self-locking nuts connecting rear differential to rear crossmember.

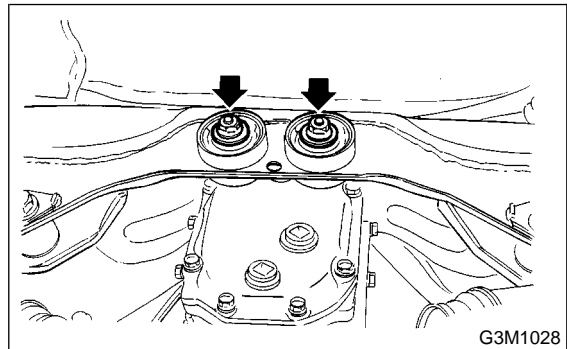

20) Remove bolts which secure rear differential front member to body.

- (1) Loosen bolt A first, then remove bolts B.

### NOTE:

Support front member with a help of an assistant to prevent it from dropping.

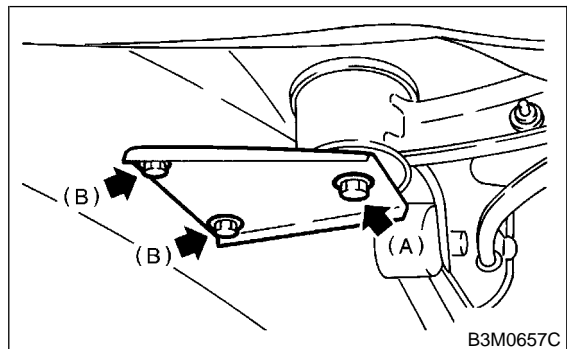

- (A) Bolt A
- (B) Bolt B

- (2) Remove bolt A.

21) While slowly lowering transmission jack, move rear differential forward and remove bolts from rear crossmember.

22) Remove front member from body.

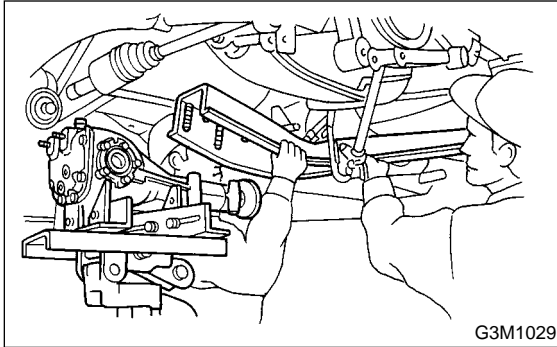

23) Remove rear differential from body.

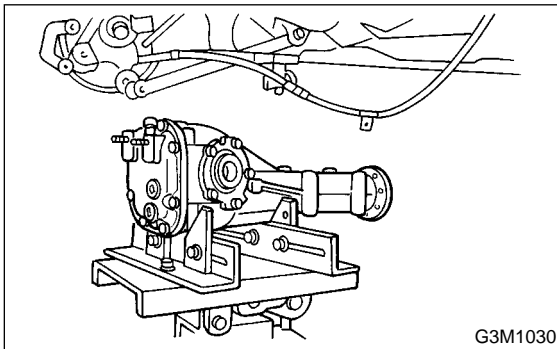

## B: INSTALLATION S303145A11

To install, reverse the removal sequence.

1) Install the air breather cap tapping with a plastic hammer.

### CAUTION:

**Be sure to install new air breather cap.**

2) Position front member on body by passing it under parking brake cable and securing to rear differential.

### NOTE:

When installing rear differential front member, do not confuse the installation sequence of the upper and lower stoppers.

3) Install DOJ of rear drive shaft into rear differential.

ST 28099PA090 SIDE OIL SEAL PROTECTOR

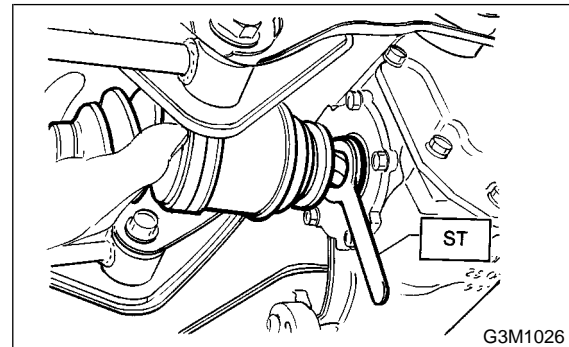

4) Install in the reverse order of removal.

5) After installing rear differential carrier on vehicle, remove filler plug and replenish gear oil up. <Ref. to DI-22, Differential Gear Oil.>

6) Connect connector to rear differential temperature sensor. (Turbo model for Europe)

7) If the results of the following inspections are not satisfactory, check rear differential temperature sensor and circuit. Then repair or replace if necessary.

(1) Check that rear differential temperature sensor warning light lights up when ignition switch is turned to on (engine stopped).

(2) Start engine, then check that the warning light goes off after a few seconds.

# REAR DIFFERENTIAL FOR T-TYPE

Differentials

## C: DISASSEMBLY S303145A06

To detect real cause of trouble, inspect the following items before disassembling.

- Tooth contact of crown gear and pinion, and backlash
- Runout of crown gear at its back surface
- Turning resistance of drive pinion

1) Set ST on vise and install the differential assembly to ST.

ST 398217700 ATTACHMENT SET

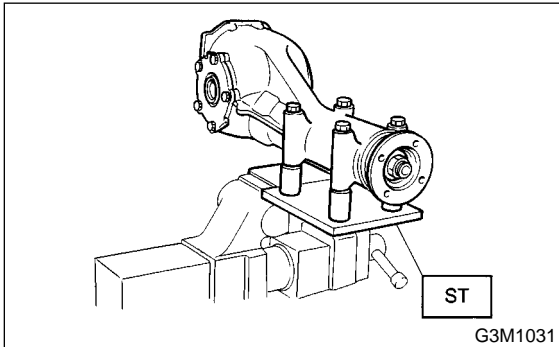

- 2) Drain gear oil by removing plug.
- 3) Remove the air breather cap.

### NOTE:

Do not attempt to replace the air breather cap unless necessary.

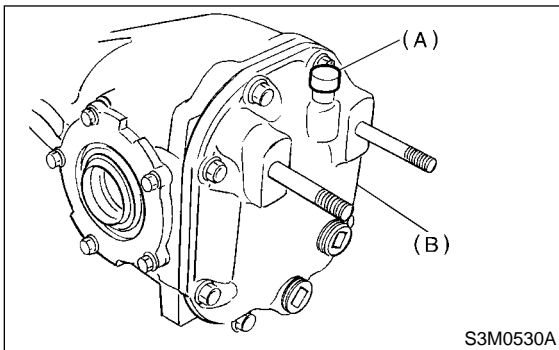

- (A) Air breather cap
- (B) Rear cover

4) Remove rear cover by loosening retaining bolts.

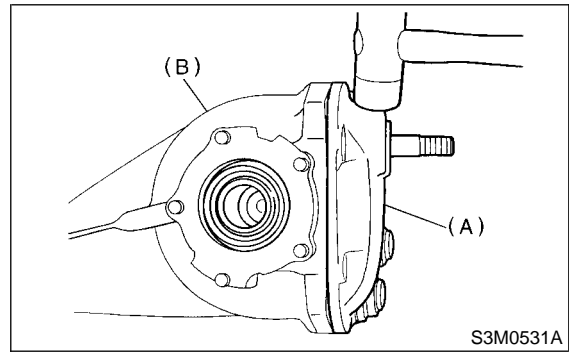

- (A) Rear cover
- (B) Differential carrier

5) Make right and left side bearing retainers in order to identify them at reassembly. Remove side bearing retainer attaching bolts, set ST to differential case, and extract right and left side bearing retainers with a puller.

### CAUTION:

Each shim, which is installed to adjust the side bearing preload, should be kept together with its mating retainer.

ST 398457700 ATTACHMENT

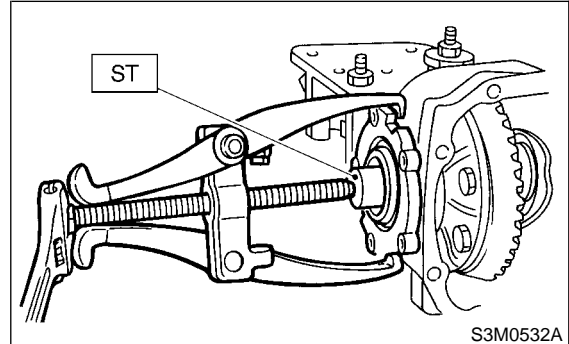

6) Pull out differential case assembly from differential carrier.

### CAUTION:

Be careful not to hit the teeth against the case.

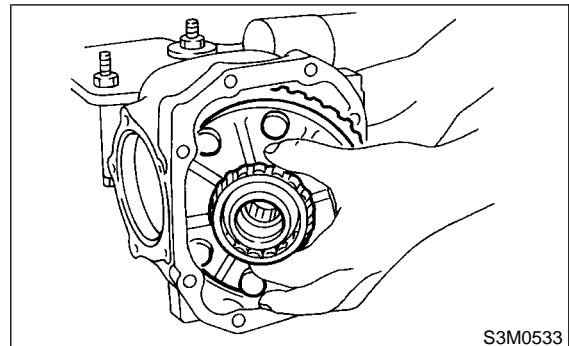

7) When replacing side bearing, pull bearing cup from side bearing retainer using ST.  
 ST 398527700 PULLER ASSY

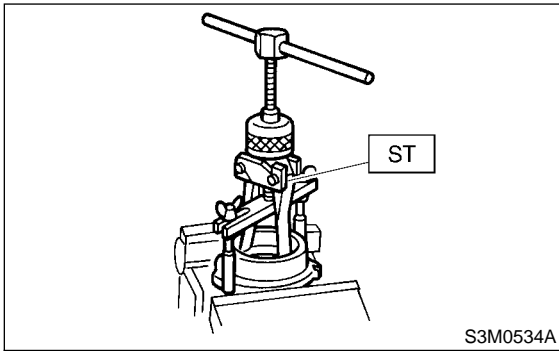

8) Extract bearing cone with ST.

**CAUTION:**  
 Do not attempt to disassemble the parts unless necessary.

**NOTE:**

- Set puller so that its claws catch the edge of the bearing cone.
- Never mix up the right and left hand bearing races and cones.

ST 399527700 PULLER SET

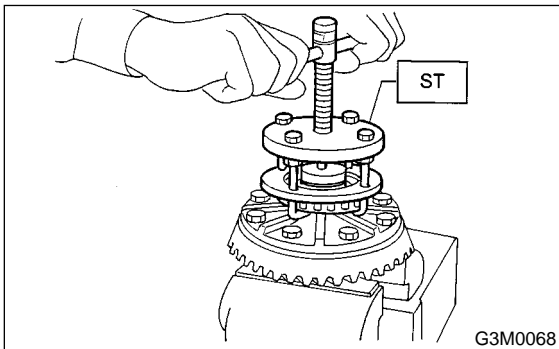

9) Remove crown gear by loosening crown gear bolts.

**CAUTION:**  
 Further disassembling is not allowed.

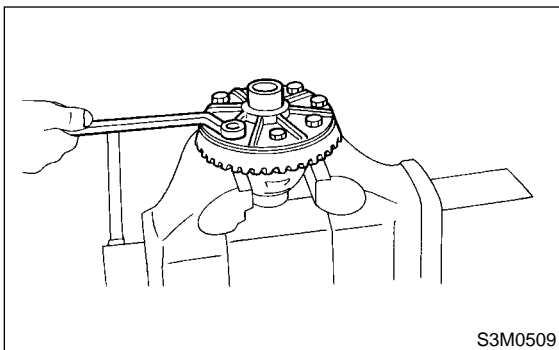

10) Drive out pinion shaft lock pin from crown gear side.

**NOTE:**  
 The lock pin is staked at the pin hole end on the differential carrier; do not drive it out forcibly before unstaking it.

ST 899904100 STRAIGHT PIN REMOVER

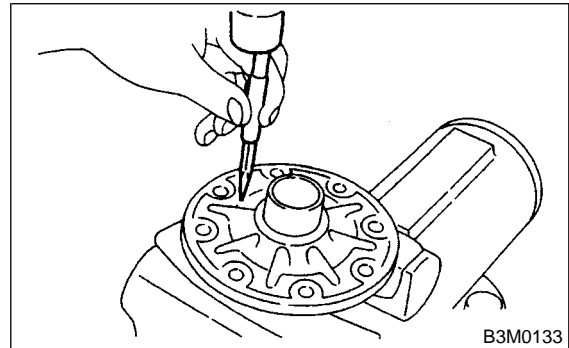

11) Draw out pinion mate shaft and remove pinion mate gears, side gears and thrust washers.

**NOTE:**  
 The gears as well as thrust washers should be marked or kept separated left and right, and front and rear.

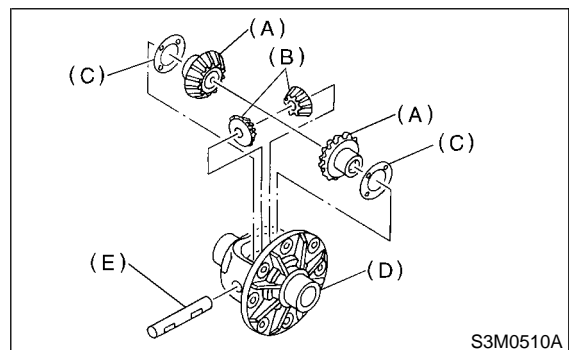

- (A) Side gear
- (B) Pinion mate gear
- (C) Thrust washer
- (D) Differential case
- (E) Pinion mate shaft

# REAR DIFFERENTIAL FOR T-TYPE

## Differentials

12) Hold companion flange with ST and remove drive pinion nut.

ST 498427200 FLANGE WRENCH

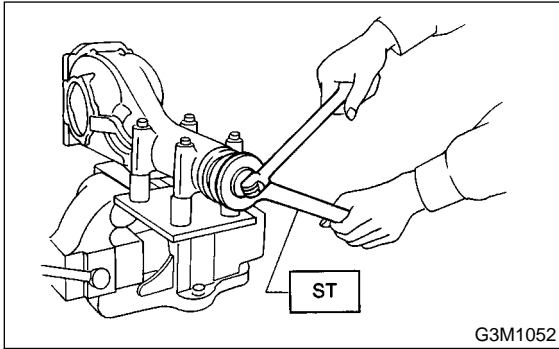

13) Extract the companion flange with a puller.

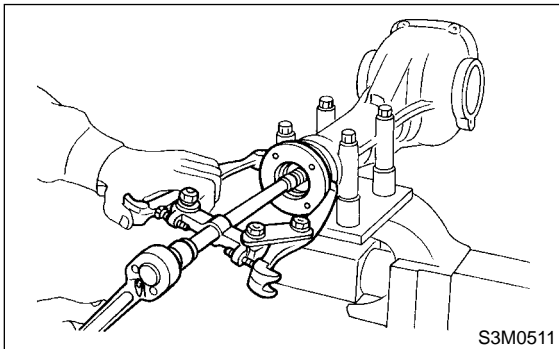

14) Press the end of drive pinion shaft and extract it together with rear bearing cone, preload adjusting spacer and washer.

NOTE:

Hold the drive pinion so as not to drop it.

ST 398467700 DRIFT

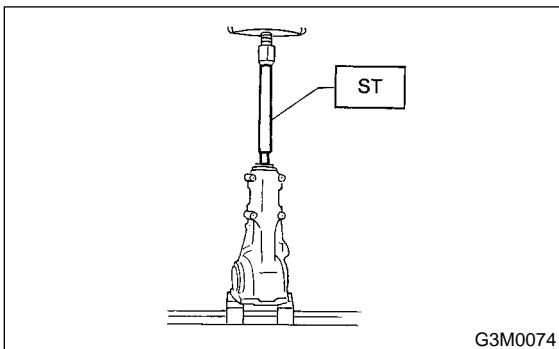

15) Remove rear bearing cone from drive pinion by supporting cone with ST.

NOTE:

Place the replacer so that its center-recessed side faces the pinion gear.

ST 398517700 REPLACER

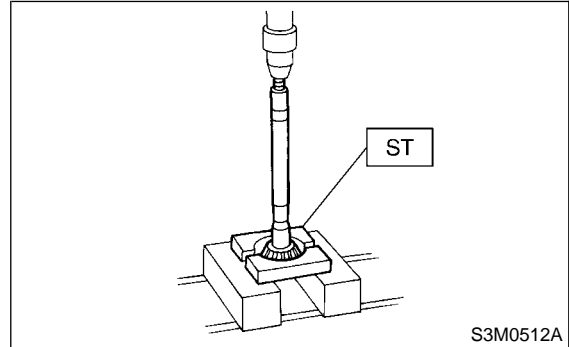

16) Remove front oil seal from differential carrier using ST.

ST 398527700 PULLER ASSY

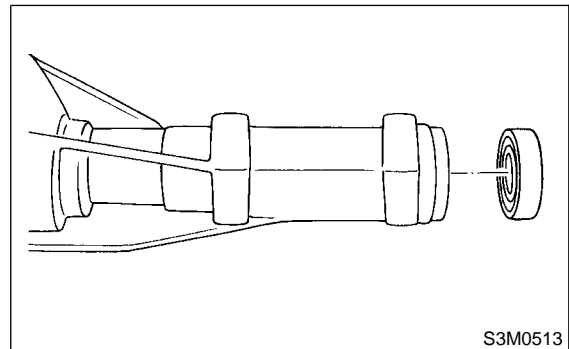

17) Remove pilot bearing together with front bearing cone using ST.

ST 398467700 DRIFT

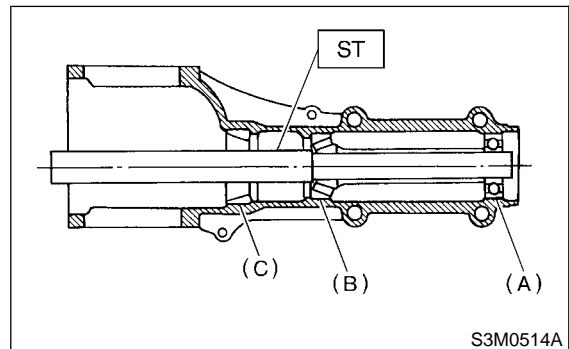

- (A) Pinion bearing
- (B) Front bearing
- (C) Rear bearing cup

18) When replacing bearings, tap front bearing cup and rear bearing cup in this order out of case by using a brass bar.

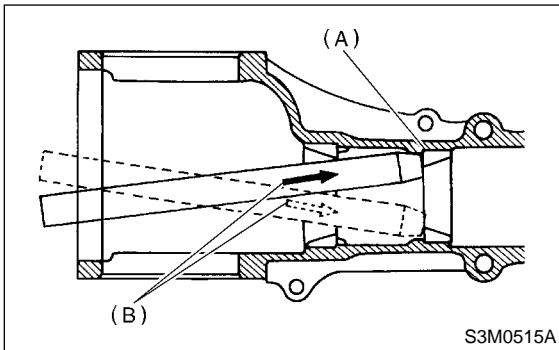

- (A) 2 cutouts along diagonal lines
- (B) Tap alternately with brass bar.

## D: ASSEMBLY S303145A02

- 1) Precautions for assembling
  - Assemble in the reverse order of disassembling.
  - Check and adjust each part during assembly.
  - For correct installation, keep the shims and washers in order.
  - Thoroughly clean the surfaces on which the shims, washers and bearings are to be installed.
  - Apply gear oil when installing the bearings and thrust washers.
  - Be careful not to mix up the right and left hand races of the bearings.
  - Replace the oil seal with new one at every disassembly. Apply chassis grease between the lips when installing the oil seal.

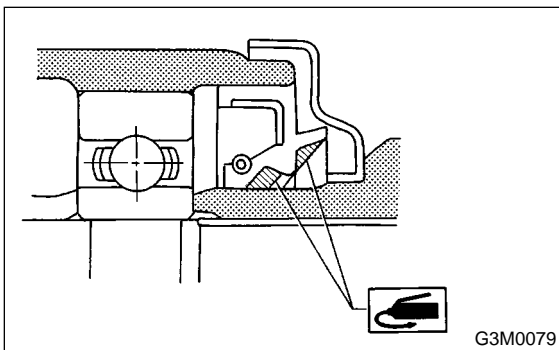

2) Adjusting preload for front and rear bearings  
Adjust the bearing preload with spacer and washer between front and rear bearings. Pinion height adjusting washer are not affected by this adjustment. The adjustment must be carried out without oil seal inserted.

- (1) Press rear bearing race into differential carrier with ST1 and ST2.
  - ST1 398477701 HANDLE
  - ST2 398477703 DRIFT 2

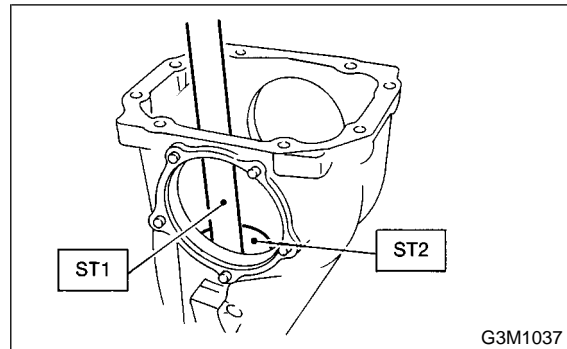

- (2) Insert ST1 into carrier with pinion height adjusting washer and rear bearing cone fitted onto it.

### CAUTION:

- Re-use the used washer if not deformed.
- Use a new rear bearing cone.

- (3) Then install preload adjusting spacer and washer, front bearing cone, ST2, companion flange, and washer and drive pinion nut.

- ST1 398507702 DUMMY SHAFT
- ST2 398507703 DUMMY COLLAR

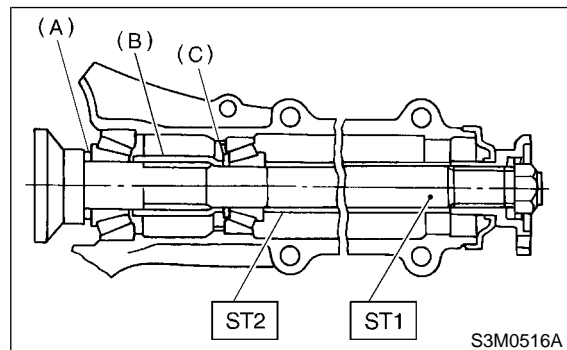

- (A) Pinion height adjusting shim
- (B) Preload adjusting spacer
- (C) Preload adjusting washer



# REAR DIFFERENTIAL FOR T-TYPE

## Differentials

(4) Turn ST1 with hand to make it seated, and tighten drive pinion nut while measuring the preload with spring balance. Select preload adjusting washer and spacer so that the specified preload is obtained when nut is tightened to the specified torque.

### CAUTION:

**Use a new lock nut.**

### NOTE:

- Be careful not to give excessive preload.
- When tightening the drive pinion nut, lock ST1 with ST2 as shown in the figure.

ST1 398507704 BLOCK

ST2 398507702 DUMMY SHAFT

### Tightening torque:

**181 N·m (18.5 kgf·m, 134 ft·lb)**

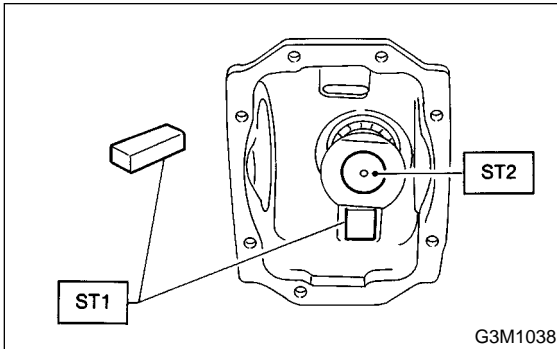

Front and rear bearing preload
For new bearing: 19.6 — 28.4 N (2.0 — 2.9 kgf, 4.4 — 6.4 lb) at companion flange bolt hole
For used bearing: 8.34 — 16.67 N (0.85 — 1.7 kgf, 1.87 — 3.75 lb) at companion flange bolt hole

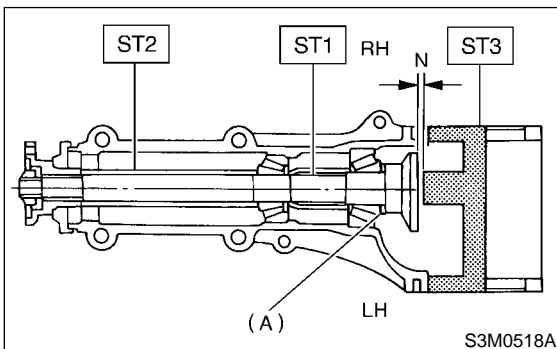

Preload adjusting washer	Part No.	Thickness mm (in)
	383705200	2.59 (0.1020)
	383715200	2.57 (0.1012)
	383725200	2.55 (0.1004)
	383735200	2.53 (0.0996)
	383745200	2.51 (0.0988)
	383755200	2.49 (0.0980)
	383765200	2.47 (0.0972)
	383775200	2.45 (0.0965)
	383785200	2.43 (0.0957)
	383795200	2.41 (0.0949)
	383805200	2.39 (0.0941)
	383815200	2.37 (0.0933)
Preload adjusting spacer	Part No.	Length mm (in)
	383695201	56.2 (2.213)
	383695202	56.4 (2.220)
	383695203	56.6 (2.228)
	383695204	56.8 (2.236)
	383695205	57.0 (2.244)
	383695206	57.2 (2.252)

### 3) Adjusting drive pinion height

Adjust drive pinion height with shim installed between rear bearing cone and the back of pinion gear.

- (1) Install ST1, ST2 and ST3, as shown in the figure, and apply the specified preload on the bearings.

Front and rear bearing preload
For new bearing: 19.6 — 28.4 N (2.0 — 2.9 kgf, 4.4 — 6.4 lb) at companion flange bolt hole
For used bearing: 8.34 — 16.67 N (0.85 — 1.7 kgf, 1.87 — 3.75 lb) at companion flange bolt hole

### Adjusting preload for front and rear bearings

### NOTE:

At this time, install a pinion height adjusting shim which is temporarily selected or the same as that used before. Measure and record the thickness.

ST1 398507702 DUMMY SHAFT

ST2 398507701 GAUGE

ST3 398507703 DUMMY COLLAR

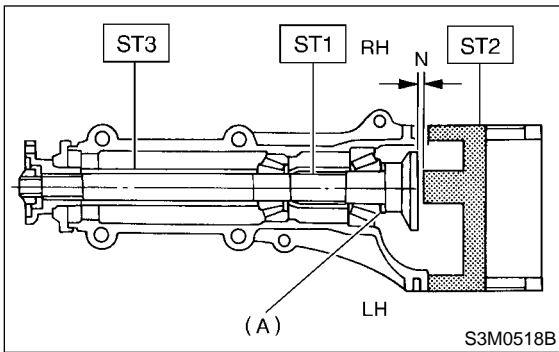

(A) Pinion height adjusting shim

(2) Measure the clearance N between the end of ST2 and the end surface of ST1 by using a thickness gauge.

**NOTE:**

Make sure there is no clearance between the case and ST2.

- ST1 398507702 DUMMY SHAFT
- ST2 398507701 GAUGE

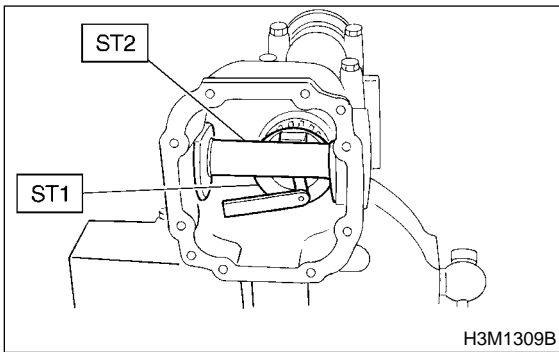

(3) Obtain the thickness of pinion height adjusting shim to be inserted from the following formula, and replace the temporarily installed shim with this one.

$$T = T_o + N - (H \times 0.01) - 0.20 \text{ mm (0.0079 in)}$$

**NOTE:**

Use copies of this page.

T	Thickness of shim temporarily inserted mm (in)	
T <sub>o</sub>	Thickness of pinion height adjusting shim mm (in)	
N	Reading of thickness gauge mm (in)	
H	Figure marked on drive pinion head	
Memo:		

(Example of calculation)

$$T_o = 2.20 + 1.20 = 3.40 \text{ mm}$$

$$N = 0.23 \text{ mm } H = + 1,$$

$$T = 3.40 + 0.23 - 0.01 - 0.20 = 3.42$$

Result: Thickness = 3.42 mm

Therefore use the shim 383605200.

Pinion height adjusting shim	
Part No.	Thickness mm (in)
383495200	3.09 (0.1217)
383505200	3.12 (0.1228)
383515200	3.15 (0.1240)
383525200	3.18 (0.1252)
383535200	3.21 (0.1264)
383545200	3.24 (0.1276)
383555200	3.27 (0.1287)
383565200	3.30 (0.1299)
383575200	3.33 (0.1311)
383585200	3.36 (0.1323)
383595200	3.39 (0.1335)
383605200	3.42 (0.1346)
383615200	3.45 (0.1358)
383625200	3.48 (0.1370)
383635200	3.51 (0.1382)
383645200	3.54 (0.1394)
383655200	3.57 (0.1406)
383665200	3.60 (0.1417)
383675200	3.63 (0.1429)
383685200	3.66 (0.1441)

4) Install the selected pinion height adjusting shim on drive pinion, and press the rear bearing cone into position with ST.

ST 398177700 INSTALLER

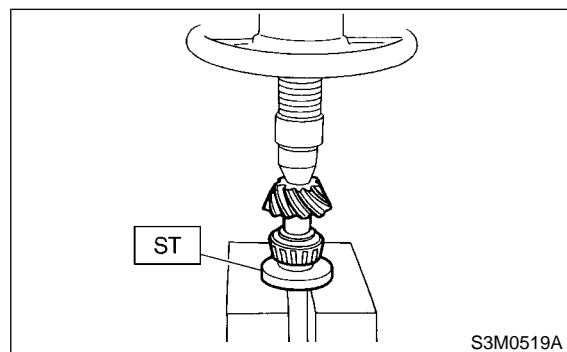

# REAR DIFFERENTIAL FOR T-TYPE

## Differentials

5) Insert drive pinion into differential carrier, install the previously selected bearing preload adjusting spacer and washer.

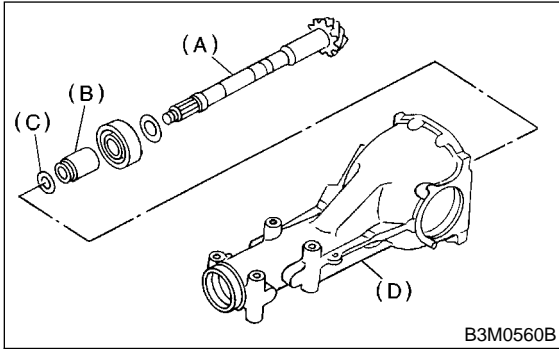

- (A) Drive pinion
- (B) Bearing adjusting spacer
- (C) Washer
- (D) Differential carrier

6) Press-fit front bearing cone into case with ST1, ST2 and ST3.

- ST1 398507703 DUMMY COLLAR
- ST2 399780104 WEIGHT
- ST3 899580100 INSTALLER

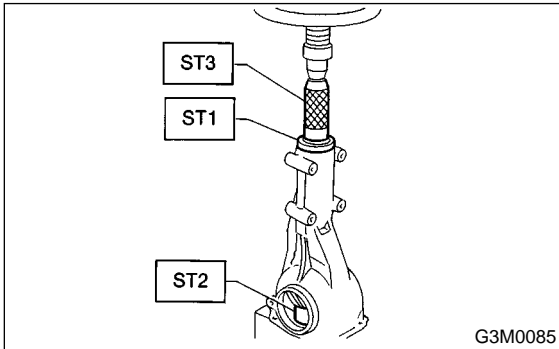

7) Insert spacer, then press-fit pilot bearing with ST1 and ST2.

- ST1 399780104 WEIGHT
- ST2 899580100 INSTALLER

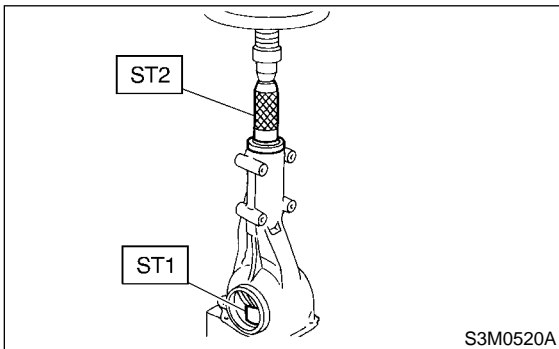

8) Fit a new oil seal with ST.

NOTE:

- Press-fit until end of oil seal is 1 mm (0.04 in) inward from end of carrier.
- Apply grease between the oil seal lips.

ST 498447120 INSTALLER

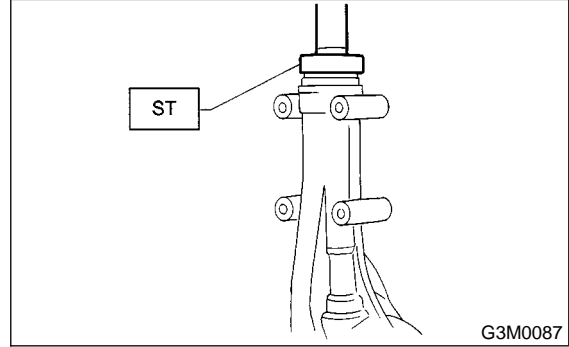

9) Press-fit companion flange with ST1 and ST2.

**CAUTION:**

**Be careful not to damage bearing.**

- ST1 899874100 INSTALLER
- ST2 399780104 WEIGHT

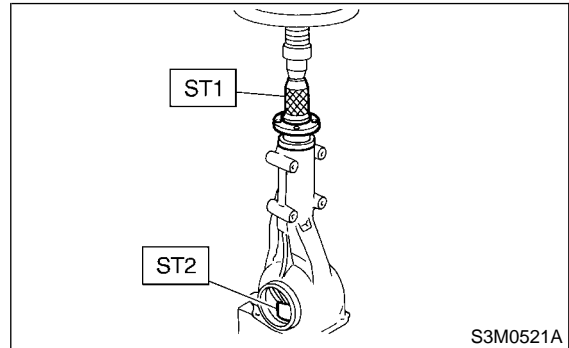

10) Install self-locking nut. Then tighten it with ST.

ST 498427200 FLANGE WRENCH

**Tightening torque:**  
**181 N-m (18.5 kgf-m, 134 ft-lb)**

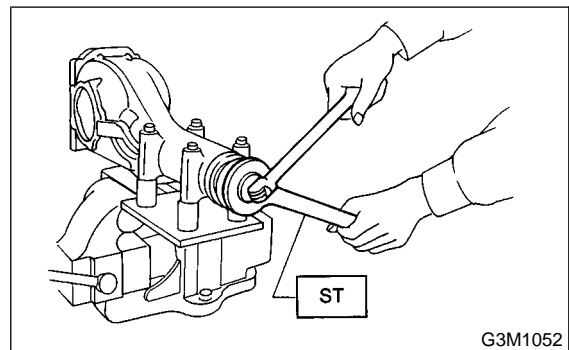

11) Assembling differential case  
Install side gears and pinion mate gears, with their thrust washers and pinion mate shaft, into differential case.

**CAUTION:**

- Apply gear oil on both sides of the washer and on the side gear shaft before installing.
- Insert the pinion mate shaft into the differential case by aligning the lock pin holes.

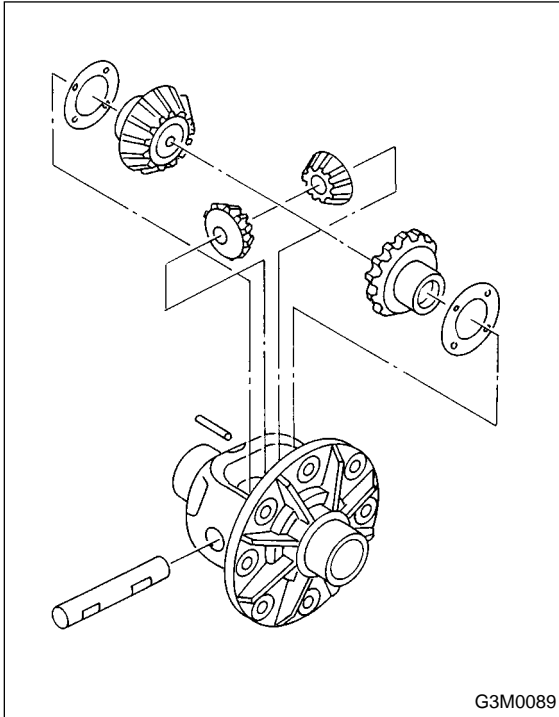

(1) Measure the side gear backlash.

**Side gear back clearance:**

**0.10 — 0.20 mm (0.0039 — 0.0079 in)**

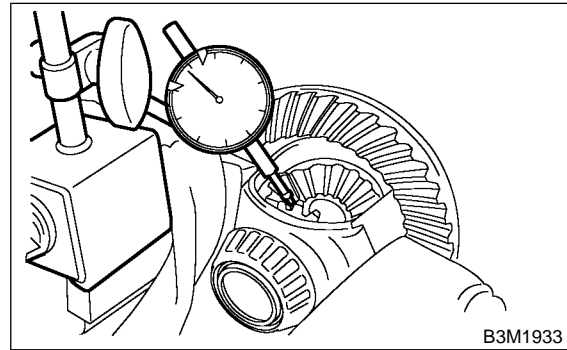

(2) Adjust the backlash as specified by selecting side gear thrust washer.

Side gear thrust washer	
Part No.	Thickness mm (in)
383445201	0.75 — 0.80 (0.0295 — 0.0315)
383445202	0.80 — 0.85 (0.0315 — 0.0335)
383445203	0.85 — 0.90 (0.0335 — 0.0354)
383445204	0.90 — 0.95 (0.0354 — 0.0374)
383445205	0.95 — 1.00 (0.0374 — 0.0394)

(3) Check the condition of rotation after applying oil to the gear tooth surfaces and thrust surfaces.

(4) After inserting pinion shaft lock pin into differential case, stake the both sides of the hole to prevent pin from falling off.

12) Install crown gear on differential case.

**CAUTION:**

**Before installing bolts, apply Lock Tite to bolt threads.**

**Lock Tite:**

**THREE BOND 1324 or equivalent**

**NOTE:**

Tighten diagonally while tapping the bolt heads.

**Tightening torque:**

**103 N·m (10.5 kgf·m, 76 ft·lb)**

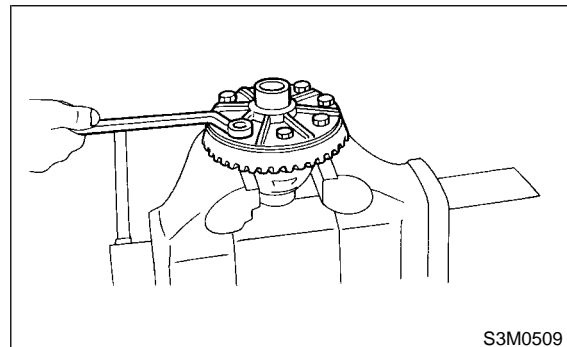

# REAR DIFFERENTIAL FOR T-TYPE

## Differentials

13) Press side bearing cone onto differential case with ST.

ST 398487700 DRIFT

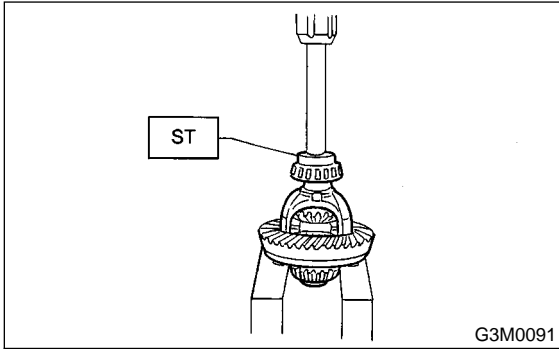

14) Adjusting side bearing retainer shims

(1) The driven gear backlash and side bearing preload can be determined by the side bearing retainer shim thickness.

(2) Install the differential case assembly into differential carrier in the reverse order of disassembly.

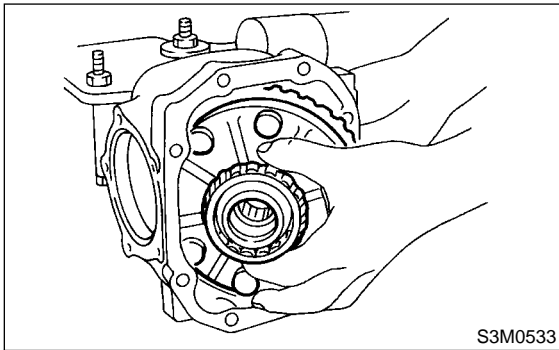

(3) Install side retainer shims and O-rings to the left and right retainers from which they were removed.

### NOTE:

- Replace broken or cracked O-ring with new one.
- Replace broken or corroded side retainer shim with new one of same thickness.

Side bearing retainer shim	
Part No.	Thickness mm (in)
383475201	0.20 (0.0079)
383475202	0.25 (0.0098)
383475203	0.30 (0.0118)
383475204	0.40 (0.0157)
383475205	0.50 (0.0197)

(4) Align arrow marked on differential carrier with that marked on side retainer during installation.

### CAUTION:

Be careful that side bearing outer race is not damaged by bearing roller.

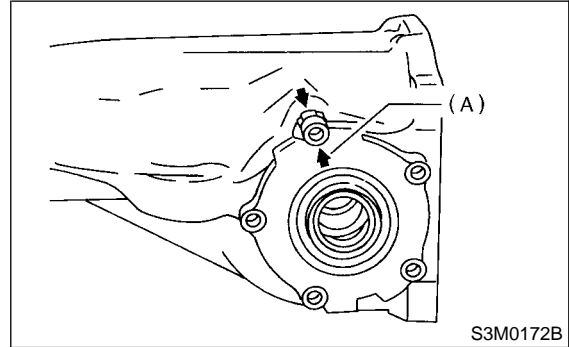

(A) Arrow mark

(5) Tighten side bearing retainer bolts.

### CAUTION:

Before tightening the two side bearing retainer bolts, apply Lock Tite to bolt threads.

⇒ Lock Tite:

**THREE BOND 1105 or equivalent**

**Tightening torque:**

**10.3 N·m (1.05 kgf-m, 7.6 ft-lb)**

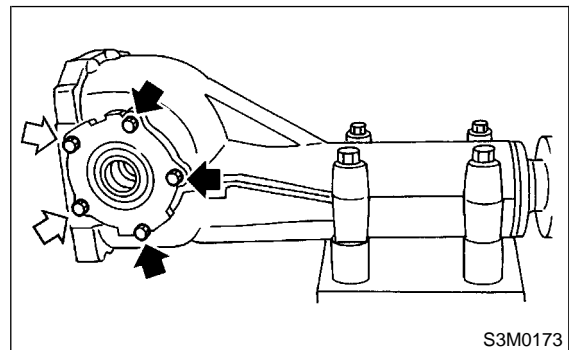

(6) Measure the crown gear-to-drive pinion backlash. Set magnet base on differential carrier. Align contact point of dial gauge with tooth face of crown gear, and move crown gear while holding drive pinion still. Read value indicated on dial gauge.

**Backlash:**

**0.10 — 0.20 mm (0.0039 — 0.0079 in)**

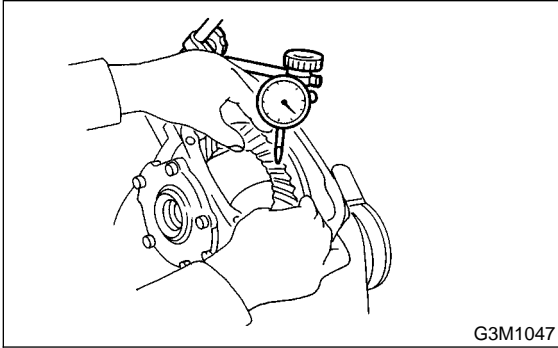

(7) At the same time, measure the turning resistance of drive pinion. Compared with the resistance when differential case is not installed, if the increase of the resistance is not within the specified range, readjust side bearing retainer shims.

**Turning resistance increase:**

**2.9 — 10.8 N (0.3 — 1.1 kgf, 0.7 — 2.4 lb)**

15) Re-check crown gear-to-pinion backlash.

**Backlash:**

**0.10 — 0.20 mm (0.0039 — 0.0079 in)**

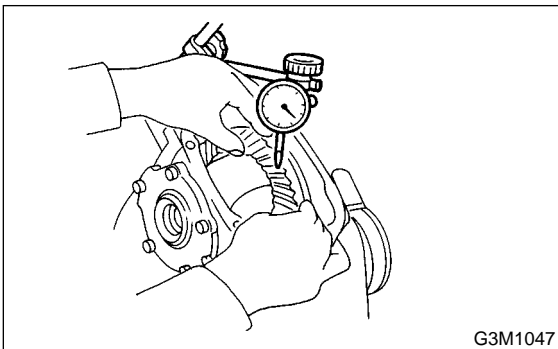

16) Check the crown gear runout on its back surface, and make sure pinion and crown gear rotate smoothly.

**Limit of runout:**

**Less than 0.05 mm (0.0020 in)**

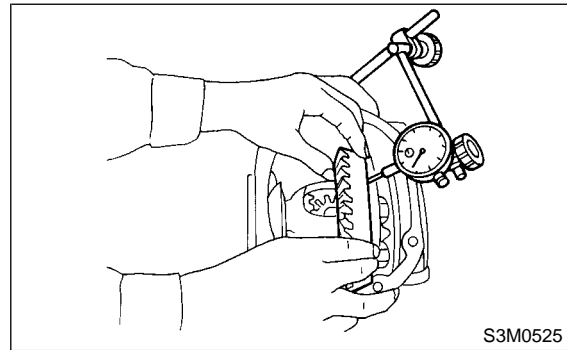

17) Checking and adjusting tooth contact of crown gear

(1) Apply an even coat of red lead on both sides of three or four teeth on the crown gear. Check the contact pattern after rotating crown gear several revolutions back and forth until a definite contact pattern appears on the crown gear.

(2) When the contact pattern is incorrect, readjust according to the instructions given in "TOOTH CONTACT PATTERN".

**NOTE:**

Be sure to wipe off red lead completely after adjustment is completed.

18) If proper tooth contact is not obtained, once again adjust the drive pinion height changing RH and LH side bearing retainer shims and the hypoid gear backlash.

# REAR DIFFERENTIAL FOR T-TYPE

## Differentials

### (1) Drive pinion height

ST1 398507702 DUMMY SHAFT  
ST2 398507701 GAUGE

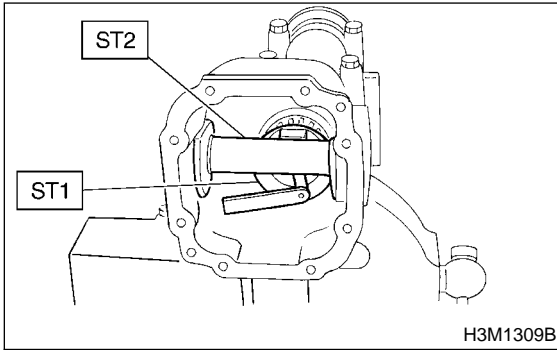

$$T = T_o + N - (H \times 0.01) - 0.20 \text{ (mm)}$$

Where:

T = Thickness of pinion height adjusting shim (mm)

T<sub>o</sub> = Thickness of shim temporarily inserted (mm)

N = Reading of thickness gauge (mm)

H = Figure marked on drive pinion head

### (2) Hypoid gear backlash

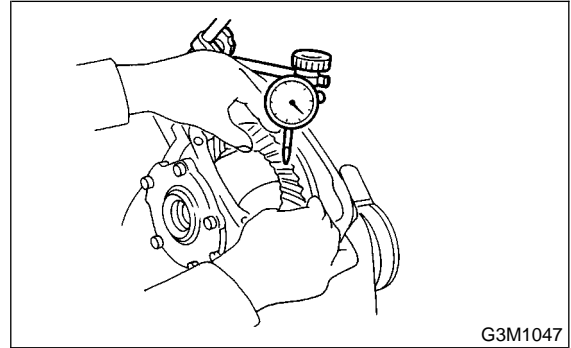

**Backlash:**

**0.10 — 0.20 mm (0.0039 — 0.0079 in)**

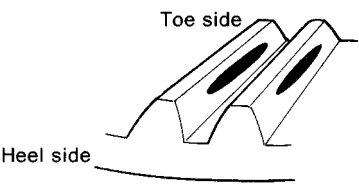
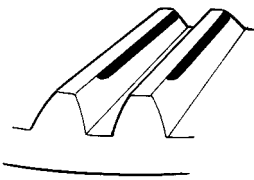
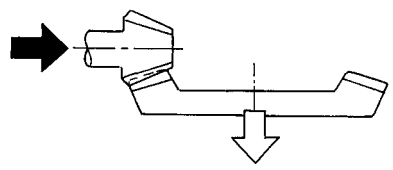
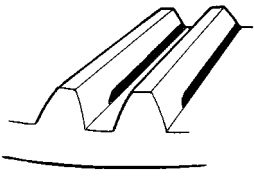
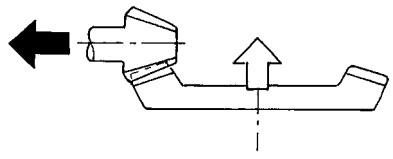
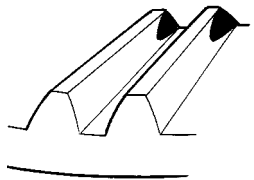
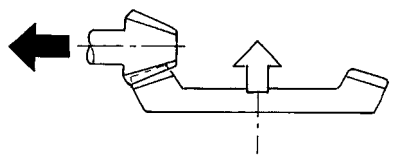
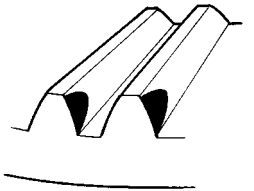
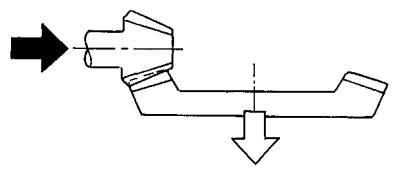

# REAR DIFFERENTIAL FOR T-TYPE

TOOTH CONTACT PATTERN		
Condition	Contact pattern	Adjustment
<p>Correct tooth contact Tooth contact pattern slightly shifted towards toe under no load rotation. (When loaded, contact pattern moves toward heel.)</p>	<p>Toe side</p>  <p>Heel side</p> <p>G3M0098A</p>	<p>—</p>
<p>Face contact Backlash is too large.</p>	<p>This may cause noise and chipping at tooth ends.</p>  <p>G3M0098B</p>	<p>Increase thickness of drive pinion height adjusting shim in order to bring drive pinion closer to crown gear center.</p>  <p>G3M0098F</p>
<p>Flank contact Backlash is too small.</p>	<p>This may cause noise and stepped wear on surfaces.</p>  <p>G3M0098C</p>	<p>Reduce thickness of drive pinion height adjusting shim in order to move drive pinion away from crown gear center.</p>  <p>G3M0098G</p>
<p>Toe contact Contact area is small.</p>	<p>This may cause chipping at toe ends.</p>  <p>G3M0098D</p>	<p>Adjust as for flank contact.</p>  <p>G3M0098G</p>
<p>Heel contact Contact area is small.</p>	<p>This may cause chipping at heel ends.</p>  <p>G3M0098E</p>	<p>Adjust as for face contact.</p>  <p>G3M0098F</p>

 : Adjusting direction of drive pinion  
 : Adjusting direction of crown gear



# REAR DIFFERENTIAL FOR T-TYPE

## Differentials

19) Install rear cover and tighten bolts to specified torque.

### CAUTION:

**Securely connect ground terminal of rear differential temperature sensor.**

### Tightening torque:

**29 N·m (3.0 kgf-m, 21.7 ft-lb)**

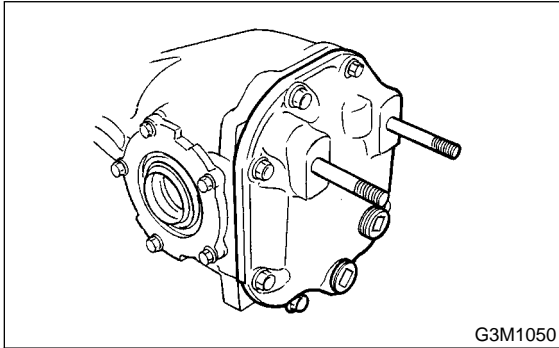

## E: INSPECTION

S303145A10

Wash all the disassembled parts clean, and examine them for wear, damage, or other defects. Repair or replace defective parts as necessary.

### 1) Crown gear and drive pinion

- If abnormal tooth contact is evident, find out the cause and adjust to give correct tooth contact at assembly. Replace the gear if excessively worn or incapable of adjustment.

- If crack, score, or seizure is evident, replace as a set. Slight damage of tooth can be corrected by oil stone or the like.

### 2) Side gear and pinion mate gear

- Replace if crack, score, or other defects are evident on tooth surface.

- Replace if thrust washer contacting surface is worn or seized. Slight damage of the surface can be corrected by oil stone or the like.

### 3) Bearing

Replace if seizure, peeling, wear, rust, dragging during rotation, abnormal noise or other defect is evident.

### 4) Thrust washers of side gear and pinion mate gear

Replace if seizure, flaw, abnormal wear or other defect is evident.

### 5) Oil seal

Replace if deformed or damaged, and at every disassembling.

### 6) Differential carrier

Replace if the bearing bores are worn or damaged.

### 7) Differential case

Replace if its sliding surfaces are worn or cracked.

### 8) Companion flange

Replace if the oil seal lip contacting surfaces have flaws.

9) Rear differential oil temperature sensor (Turbo model for Europe)

If the results of the following inspections are not satisfactory, replace rear differential temperature sensor.

(1) At room temperature, check for continuity between the sensor terminal and body.

(2) Soak the sensor in oil, then raise the oil temperature. Check that the continuity is cut off when the oil temperature is between 144°C (291°F) and 156°C (313°F). Then, check that the continuity resumes by the time the oil temperature drops to 135°C (275°F).

### CAUTION:

**The oil is hot, so be careful not to burn yourself when inspecting.**

## 1. SIDE GEAR BACKLASH

S303145A1001

Using a dial gauge, check the backlash of the side gear.

### Side gear backlash:

**0.1 — 0.2 mm (0.004 — 0.008 in)**

If side gear backlash is not within the specification, adjust clearance as specified by selecting side gear thrust washer.

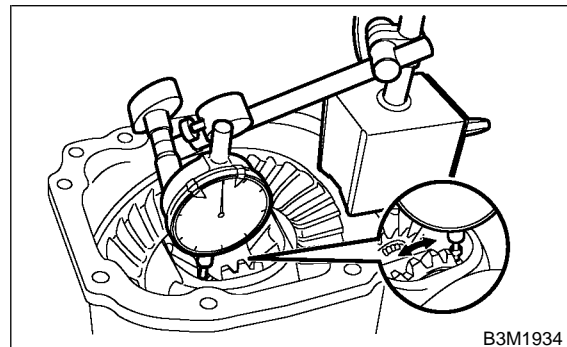

## 2. CROWN GEAR BACKLASH S303145A1002

Using a dial gauge, check the backlash of the crown gear.

**Crown gear backlash:**  
**0.1 — 0.2 mm (0.004 — 0.008 in)**

If crown gear backlash is not within the specification, adjust the side bearing preload or repair if necessary.

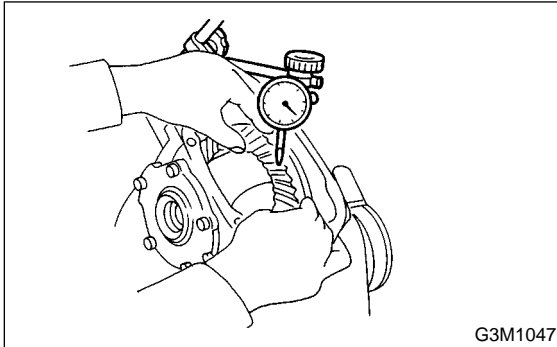

## 3. CROWN GEAR RUNOUT S303145A1003

Using a dial gauge, check the crown gear runout.

**Crown gear runout:**  
**Less than 0.05 mm (0.0020 in)**

If the crown gear runout exceeds 0.05 mm (0.0020 in), replace the crown gear.

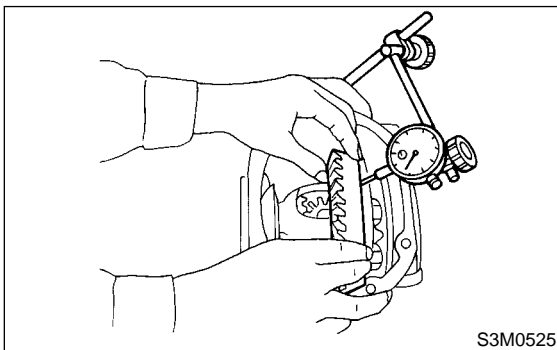

## 4. TOOTH CONTACT BETWEEN CROWN GEAR AND DRIVE PINION S303145A1004

Inspect tooth contact between crown gear and driven pinion. <Ref. to DI-31 ASSEMBLY, Differential for T-type.>

## 5. TOTAL PRELOAD S303145A1005

Using a gauge, check the turning resistance increase.

**Total preload:**  
**2.9 — 10.8 N (0.3 — 1.1 kgf, 0.7 — 2.4 lb)**

If the increase of the resistance is not within the specification, adjust the side bearing retainer shims.

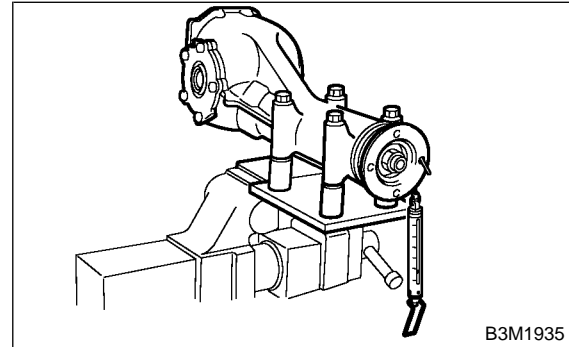

## F: ADJUSTMENT S303145A01

### 1. SIDE GEAR BACKLASH A303145A0101

Adjust side gear backlash.  
 <Ref. to DI-31 ASSEMBLY, Differential for T-type.>

### 2. CROWN GEAR BACKLASH A303145A0102

Adjust crown gear backlash.  
 <Ref. to DI-31 ASSEMBLY, Differential for T-type.>

### 3. TOOTH CONTACT BETWEEN CROWN GEAR AND DRIVE PINION A303145A0103

Adjust the tooth contact between crown gear and drive pinion gear.  
 <Ref. to DI-31 ASSEMBLY, Differential for T-type.>

### 4. TOTAL PRELOAD A303145A0104

Adjust side bearing shim.  
 <Ref. to DI-31 ASSEMBLY, Differential for T-type.>

## 5. Rear Differential for VA-type

S303151

### A: REMOVAL S303151A18

- 1) Set vehicle on a lift.
- 2) Disconnect ground terminal from battery.
- 3) Move select lever or gear shift lever to "N".
- 4) Release the parking brake.
- 5) Loosen wheel nuts.
- 6) Jack-up vehicle and support it with sturdy racks.
- 7) Remove wheels.
- 8) Remove rear exhaust pipe and muffler.

With OBD:

<Ref. to EX(SOHC)-9, REMOVAL, Rear Exhaust Pipe.> and <Ref. to EX(SOHC)-11, REMOVAL, Muffler.>

Without OBD:

<Ref. to EX(SOHCw/oOBD)-10, REMOVAL, Rear Exhaust Pipe.> and <Ref. to EX(SOHCw/oOBD)-12, REMOVAL, Muffler.>

- 9) Remove front exhaust cover.

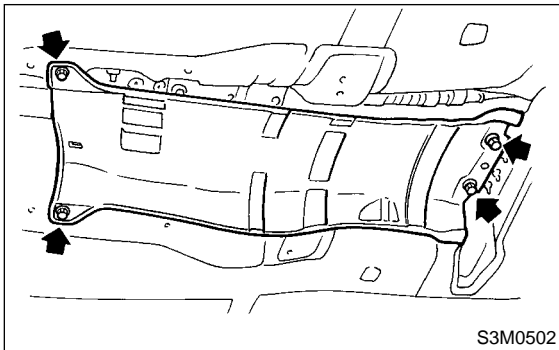

- 10) Remove front cover of rear differential mount.

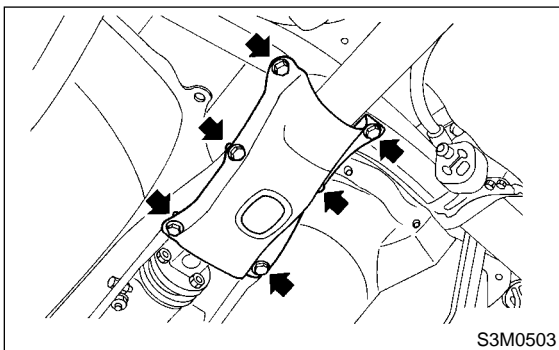

- 11) Remove propeller shaft. <Ref. to DS-14, REMOVAL, Propeller Shaft.>

- 12) Remove heat sealed cover.

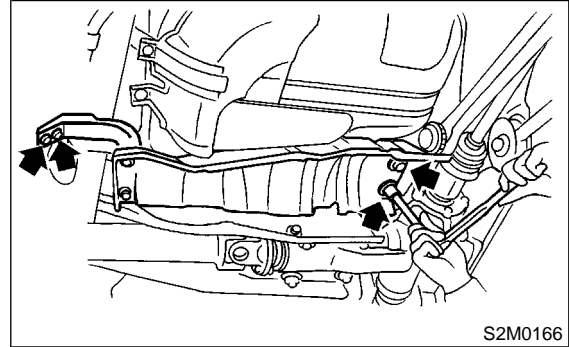

- 13) Remove clamps and bracket of parking brake cable.

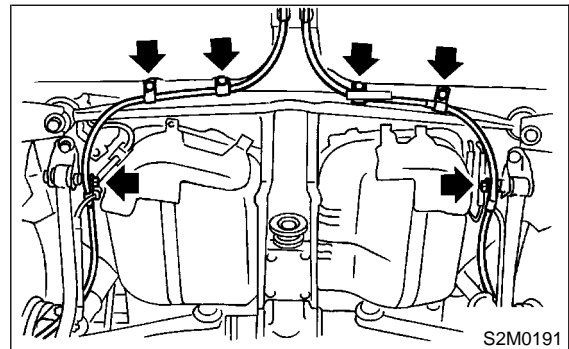

- 14) Remove DOJ of rear drive shaft from rear differential. <Ref. to DS-38, REMOVAL, Rear Drive Shaft.>

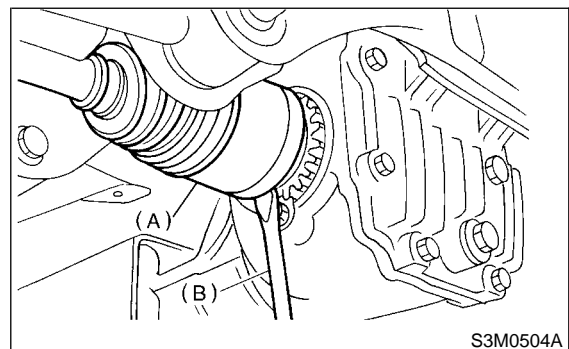

- (A) DOJ  
(B) Tire lever

15) Secure rear drive shaft to rear crossmember using wire.

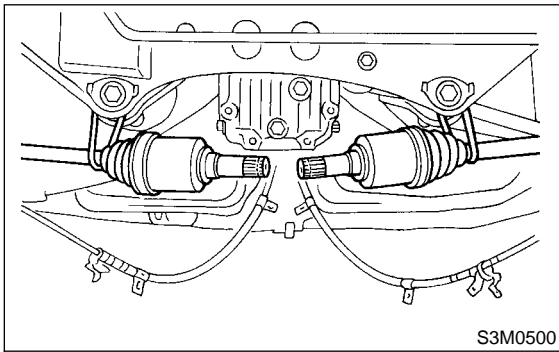

16) Remove lower differential bracket.

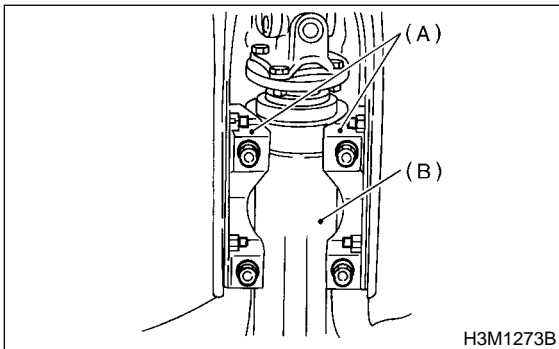

- (A) Lower differential bracket
- (B) Rear differential

17) Support rear differential with transmission jack.

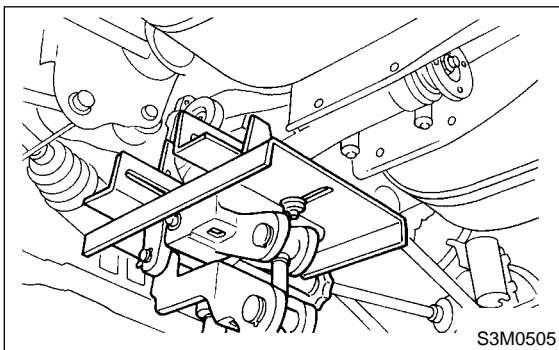

18) Remove self-locking nuts connecting rear differential to rear crossmember.

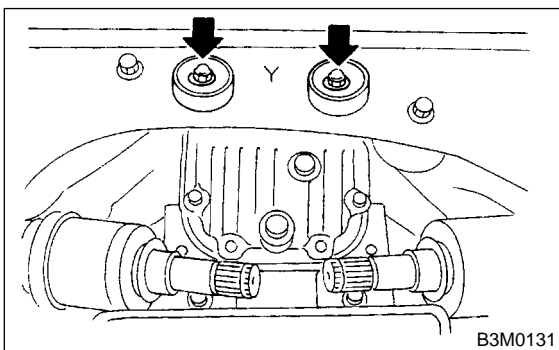

19) Remove bolts which secure rear differential front member to body.

(1) Loosen bolt A first, then remove bolts B.

NOTE:

Support front member with a help of an assistant to prevent it from dropping.

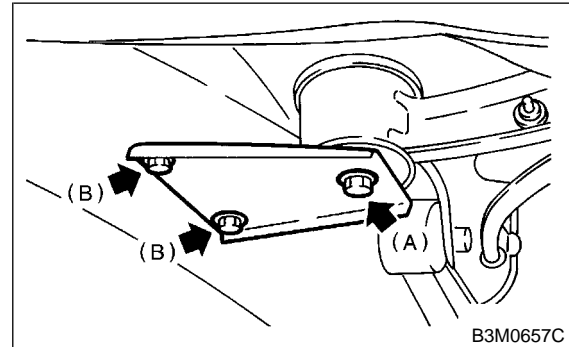

- (A) Bolt A
- (B) Bolt B

(2) Remove bolt A.

20) While slowly lowering transmission jack, move rear differential forward and remove bolts from rear crossmember.

21) Remove front member from body.

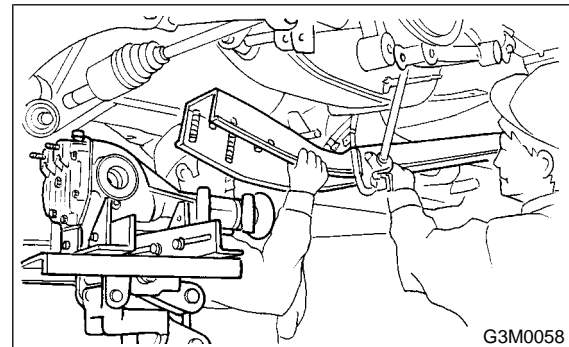

22) Remove rear differential from body.

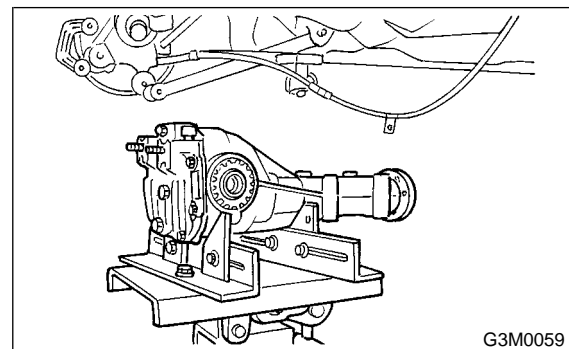

## B: INSTALLATION S303151A11

To install, reverse the removal sequence.

1) Position front member on body by passing it under parking brake cable and securing to rear differential.

# REAR DIFFERENTIAL FOR VA-TYPE

## Differentials

### NOTE:

When installing rear differential front member, do not confuse the installation sequence of the upper and lower stoppers.

2) Install DOJ of rear drive shaft into rear differential.

ST 28099PA090 SIDE OIL SEAL PROTECTOR

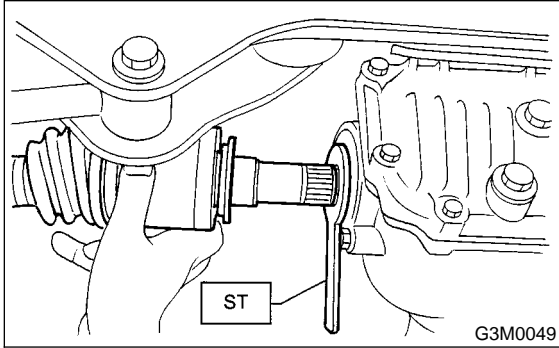

3) Install in the reverse order of removal.

4) After installation, fill differential carrier with gear oil. <Ref. to DI-22, Differential Gear Oil.>

## C: DISASSEMBLY

S303151A06

To detect real cause of trouble, inspect the following items before disassembling.

- Tooth contact of crown gear and pinion, and backlash
- Runout of crown gear at its back surface
- Turning resistance of drive pinion

1) Set ST on vise and install the differential assembly to ST.

ST 398217700 ATTACHMENT

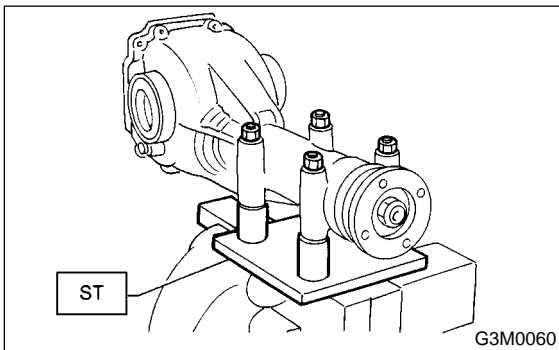

2) Drain gear oil by removing plug.

3) Remove rear cover by loosening retaining bolts.

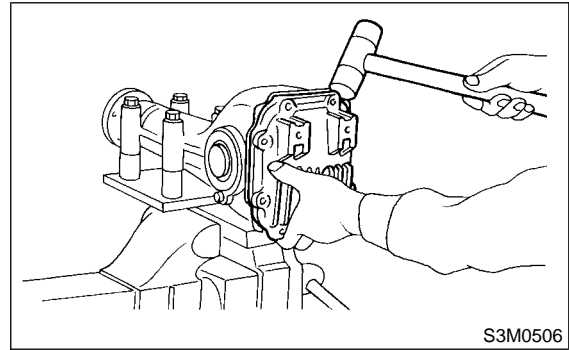

4) Replace air breather cap.

### NOTE:

Do not attempt to replace the air breather cap unless necessary.

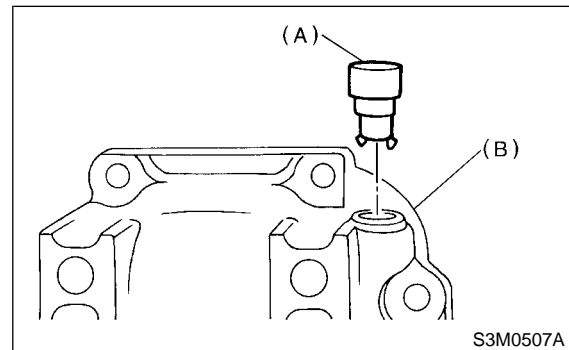

- (A) Air breather cap  
(B) Rear cover

5) Remove right and left lock plates.

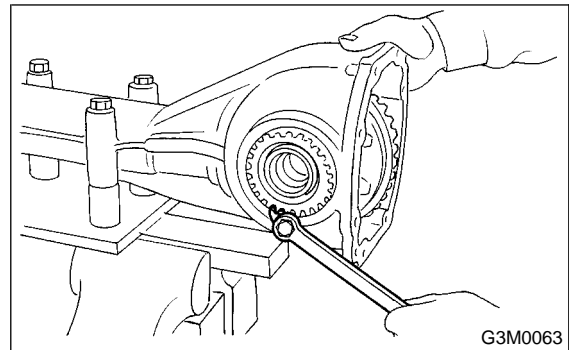

6) Remove right and left holders with ST.  
ST 399780111 WRENCH

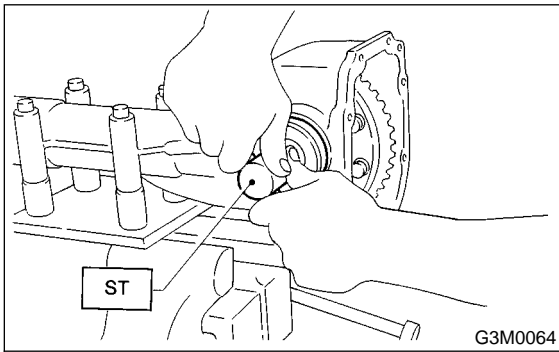

7) Pull out differential assembly from differential case.

**CAUTION:**  
Be careful not to hit the teeth against the case.

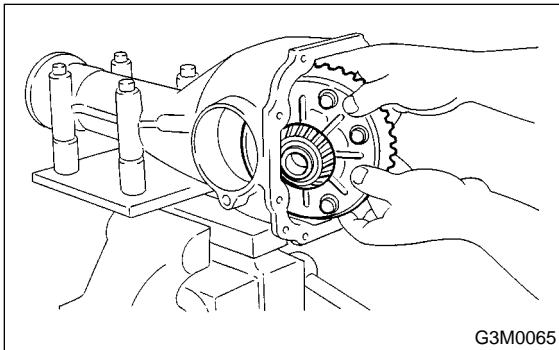

8) Remove bearing race from right and left holders with ST1 and ST2.

ST1 499705401 PULLER ASSY  
ST2 499705404 OUTER RACE PULLER SEAT

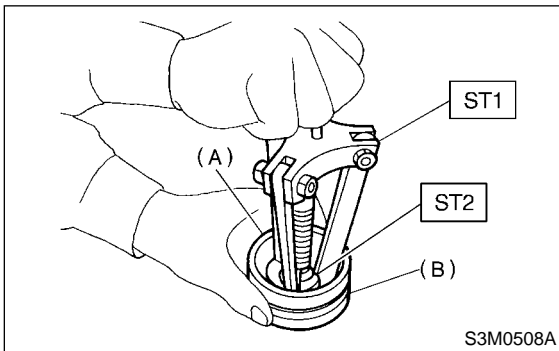

(A) Bearing race  
(B) Holder

9) Remove oil seal from right and left holders with screwdriver.

**CAUTION:**  
Perform this operation only when changing oil seal.

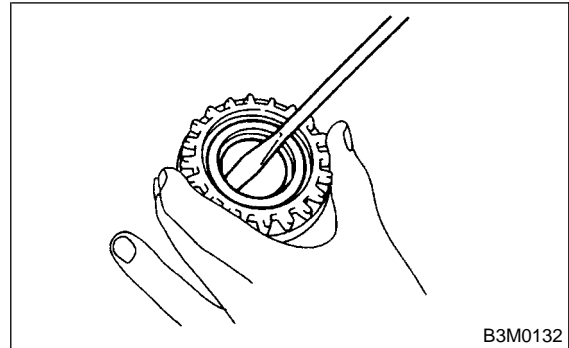

10) Extract bearing cone with ST1 and ST2.

**CAUTION:**  
Do not attempt to disassemble the parts unless necessary.

NOTE:

- Set Puller so that its claws catch the edge of the bearing cone.
- Never mix up the right and left hand bearing races and cones.

ST1 899524100 PULLER SET  
ST2 399520105 SEAT

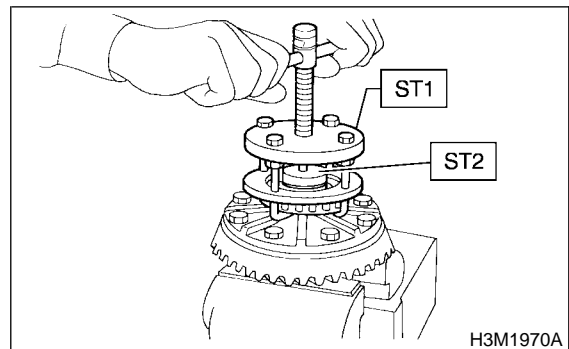

11) Remove crown gear by loosening crown gear bolts.

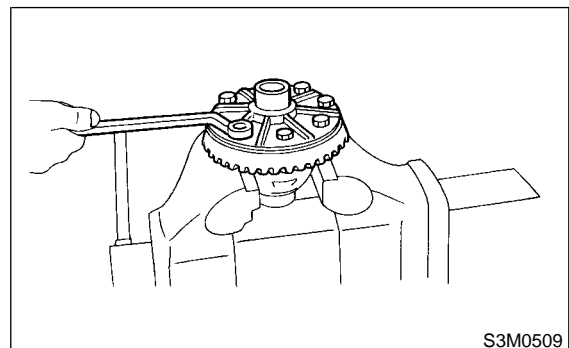

# REAR DIFFERENTIAL FOR VA-TYPE

## Differentials

12) Drive out pinion shaft lock pin from crown gear side.

**NOTE:**

The lock pin is staked at the pin hole end on the differential case; do not drive it out forcibly before unstaking it.

ST 899904100 STRAIGHT PIN REMOVER

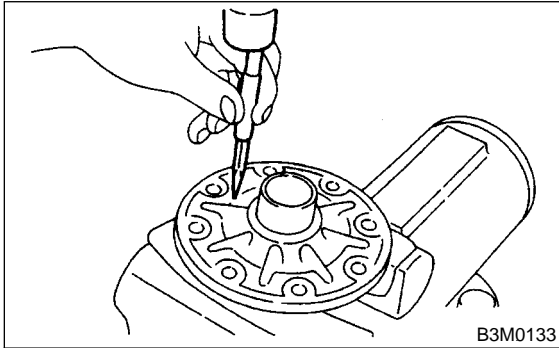

13) Draw out pinion mate shaft and remove pinion mate gears, side gears and thrust washers.

**NOTE:**

The gears as well as thrust washers should be marked or kept separated left and right, and front and rear.

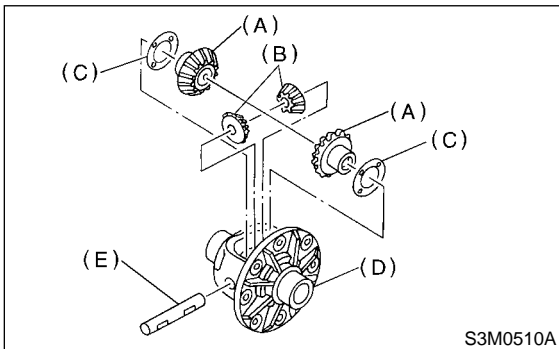

- (A) Side gear
- (B) Pinion mate gear
- (C) Thrust washer
- (D) Differential case
- (E) Pinion mate shaft

14) Hold companion flange with ST and remove self-locking nut.

ST 498427200 FLANGE WRENCH

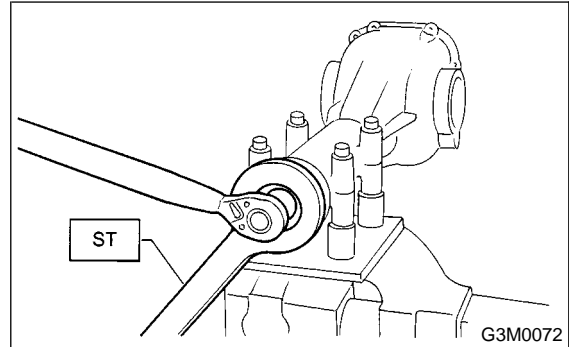

15) Extract the companion flange with a puller.

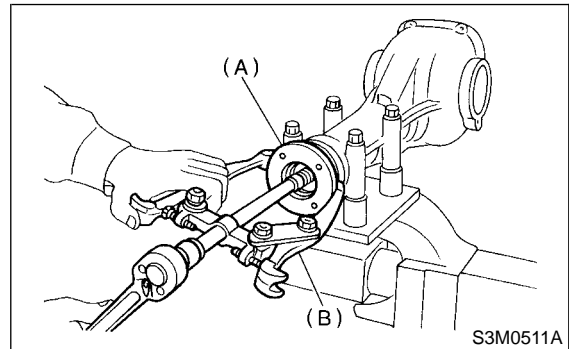

- (A) Companion
- (B) Puller

16) Press the end of drive pinion shaft and extract it together with rear bearing cone, preload adjusting spacer and washer.

**NOTE:**

Hold the drive pinion so as not to drop it.

ST 398467700 DRIFT

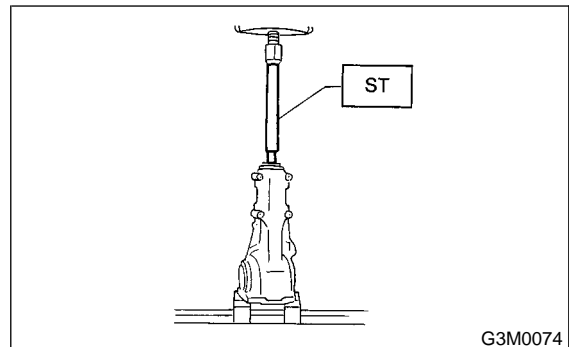

17) Remove rear bearing cone from drive pinion by supporting cone with ST.

**NOTE:**

Place the replacer so that its center-recessed side faces the pinion gear.

ST 498515500 REPLACER

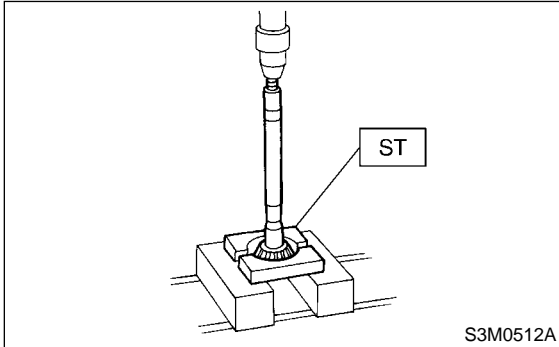

18) Remove front oil seal from differential carrier using ST.

ST 398527700 PULLER ASSY

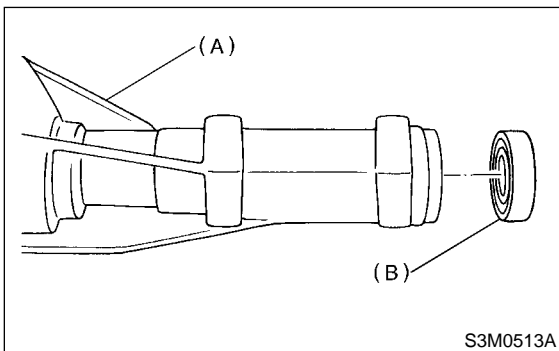

- (A) Differential carrier
- (B) Front oil seal

19) Remove pilot bearing together with front bearing cone using ST.

ST 398467700 DRIFT

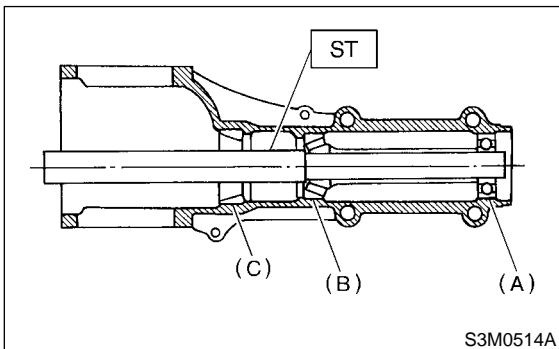

- (A) Pilot bearing
- (B) Front bearing
- (C) Rear bearing cup

20) When replacing bearings, tap front bearing cup and rear bearing cup in this order out of case by using a brass bar.

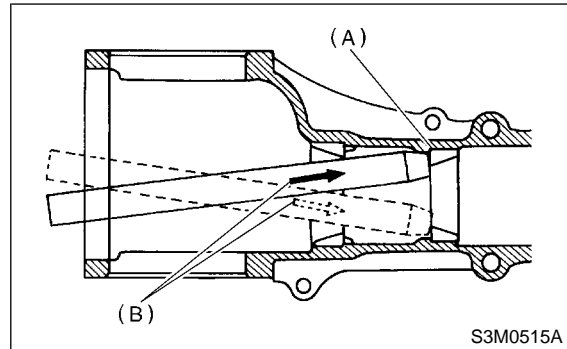

- (A) 2 cutouts along diagonal lines
- (B) Tap alternately with brass bar.

## D: ASSEMBLY

S303151A02

1) Precautions for assembling

- Assemble in the reverse order of disassembling.
- Check and adjust each part during assembly.
- Keep the shims and washers in order, so that they are not misinstalled.
- Thoroughly clean the surfaces on which the shims, washers and bearings are to be installed.
- Apply gear oil when installing the bearings and thrust washers.
- Be careful not to mix up the right and left hand races of the bearings.
- Replace the oil seal with new one at every disassembly. Apply chassis grease between the lips when installing the oil seal.

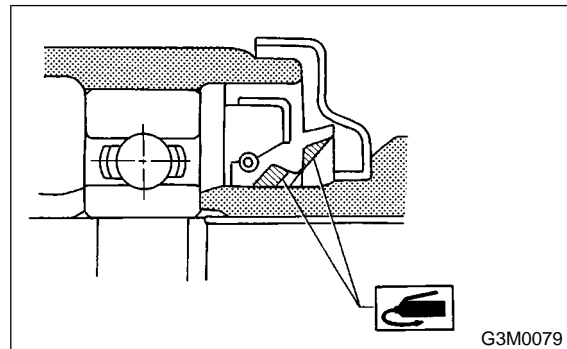

2) Adjust preload for front and rear bearings.

Adjust the bearing preload with spacer and washer between front and rear bearings. Pinion height adjusting washer are not affected by this adjustment. The adjustment must be carried out without oil seal inserted.



# REAR DIFFERENTIAL FOR VA-TYPE

## Differentials

(1) Press rear bearing race into differential carrier with ST1 and ST2.

ST1 398477701 HANDLE  
ST2 398477702 DRIFT

(2) Press front bearing race into differential carrier with ST1 and ST2.

ST1 398477701 HANDLE  
ST2 498447110 DRIFT

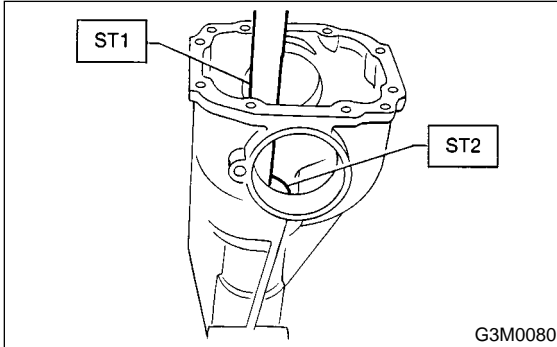

(3) Insert front bearing cone.

### CAUTION:

**Use a new front bearing cone.**

(4) Insert ST1 into case with pinion height adjusting shim and rear bearing cone fitted onto it.

### CAUTION:

- Re-use the used washer if not deformed.
- Use a new rear bearing cone.

(5) Then install preload adjusting spacer and washer, front bearing cone, ST2, companion flange, and washer and self-locking nut.

ST1 498447150 DUMMY SHAFT  
ST2 32285AA000 DUMMY COLLAR

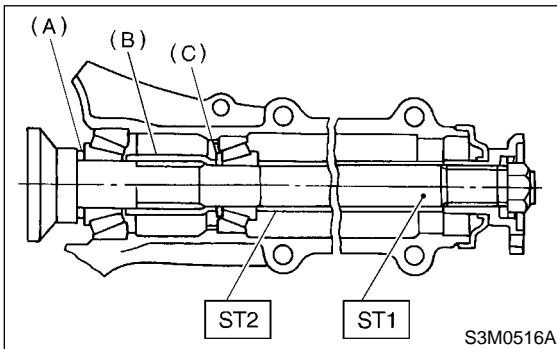

- (A) Pinion height adjusting shim  
(B) Preload adjusting spacer  
(C) Preload adjusting washer

(6) Turn ST1 with hand to make it seated, and tighten drive pinion nut while measuring the preload with spring balance. Select preload adjusting washer and spacer so that the specified preload is obtained when nut is tightened to the specified torque.

### CAUTION:

**Use a new self-locking nut.**

### NOTE:

- Be careful not to give excessive preload.
- When tightening the drive pinion nut, lock ST1 with ST2 as shown in the figure.

ST1 398507704 BLOCK  
ST2 498447150 DUMMY SHAFT

### Tightening torque:

**188 N·m (19.2 kgf·m, 139 ft·lb)**

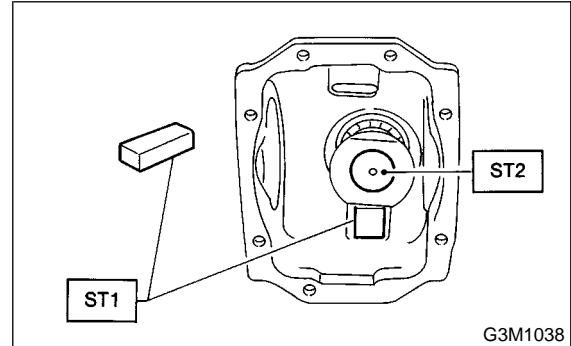

### Front and rear bearing preload

For new bearing:

12.7 — 32.4 N (1.3 — 3.3 kgf, 2.9 — 7.3 lb)

at companion flange bolt hole

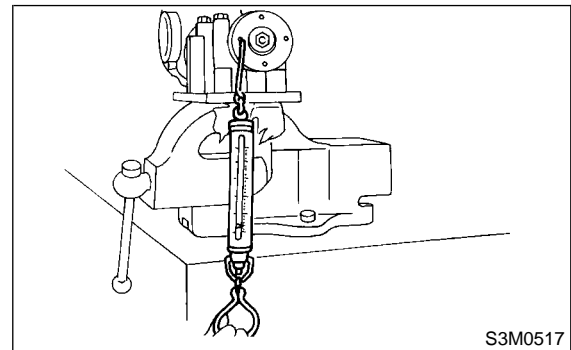

# REAR DIFFERENTIAL FOR VA-TYPE

Differentials

Preload adjusting washer	Part No.	Thickness mm (in)
	38336AA000	1.500 (0.0591)
	38336AA120	1.513 (0.0596)
	38336AA010	1.525 (0.0600)
	38336AA130	1.538 (0.0606)
	38336AA020	1.550 (0.0610)
	38336AA140	1.563 (0.0615)
	38336AA030	1.575 (0.0620)
	38336AA150	1.588 (0.0625)
	38336AA040	1.600 (0.0630)
	38336AA160	1.613 (0.0635)
	38336AA050	1.625 (0.0640)
	38336AA170	1.638 (0.0645)
	38336AA060	1.650 (0.0650)
	38336AA180	1.663 (0.0655)
	38336AA070	1.675 (0.0659)
	38336AA190	1.688 (0.0665)
	38336AA080	1.700 (0.0669)
	38336AA200	1.713 (0.0674)
	38336AA090	1.725 (0.0679)
38336AA210	1.738 (0.0684)	
38336AA100	1.750 (0.0689)	
38336AA220	1.763 (0.0694)	
38336AA110	1.775 (0.0699)	
Preload adjusting spacer	Part No.	Length mm (in)
	32288AA040	52.3 (2.059)
	32288AA050	52.5 (2.067)
	31454AA100	52.6 (2.071)
	32288AA060	52.7 (2.075)
	31454AA110	52.8 (2.079)
	32288AA070	52.9 (2.083)
	31454AA120	53.0 (2.087)
	32288AA080	53.1 (2.091)
	32288AA090	53.3 (2.098)

## ST3 498505501 DIFFERENTIAL CARRIER GAUGE

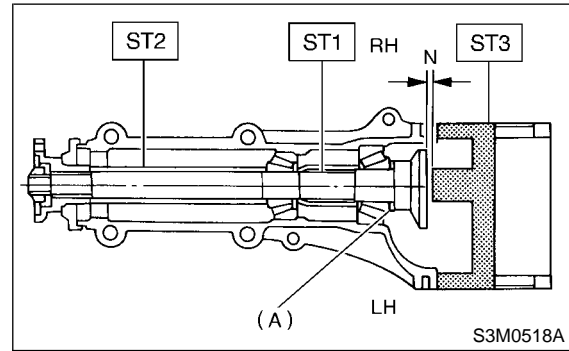

(A) Pinion height adjusting shim

(2) Measure the clearance N between the end of ST3 and the end surface of ST1 by using a thickness gauge.

### NOTE:

Make sure there is no clearance between the case and ST3.

## ST1 498447150 DUMMY SHAFT ST2 498505501 DIFFERENTIAL CARRIER GAUGE

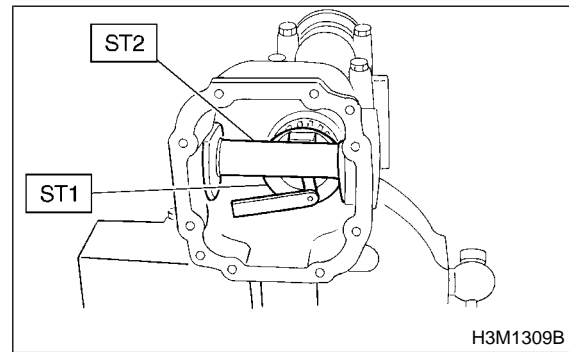

### 3) Adjusting drive pinion height

Adjust drive pinion height with shim installed between rear bearing cone and the back of pinion gear.

(1) Install ST1, ST2 and ST3, as shown in the figure, and apply the specified preload on the bearings

Front and rear bearing preload
For new bearing: 12.7 — 32.4 N (1.3 — 3.3 kgf, 2.9 — 7.3 lb) at companion flange bolt hole

Adjusting preload for front and rear bearings

### NOTE:

At this time, install an original pinion height adjusting shim.

ST1 498447150 DUMMY SHAFT  
ST2 32285AA000 DUMMY COLLAR

# REAR DIFFERENTIAL FOR VA-TYPE

## Differentials

(3) Obtain the thickness of pinion height adjusting washer to be inserted from the following formula, and replace the temporarily installed shim with this one.

### NOTE:

Use 1 to 3 shims as required for adjustment.

$$T = To + N - 0.05 \text{ (mm)}$$

where

T = Thickness of pinion height adjusting shim (mm)

To = Thickness of shim originally installed (mm)

N = Reading of thickness gauge (mm)

H = Figure marked on drive pinion head

(Example of calculation)

$$To = 0.15 \text{ mm}$$

$$N = 0.1 \text{ mm}$$

$$T = 0.15 + 0.1 - 0.05 = 0.2 \text{ mm}$$

Result: Thickness = 0.2 mm

Therefore use the 32295AA220.

Pinion height adjusting shim	
Part No.	Thickness mm (in)
32295AA200	0.150 (0.0059)
32295AA210	0.175 (0.0069)
32295AA220	0.200 (0.0079)
32295AA230	0.225 (0.0089)
32295AA240	0.250 (0.0098)
32295AA250	0.275 (0.0108)

4) Install the selected pinion height adjusting shim on drive pinion, and press the rear bearing cone into position with ST.

ST 498175500 INSTALLER

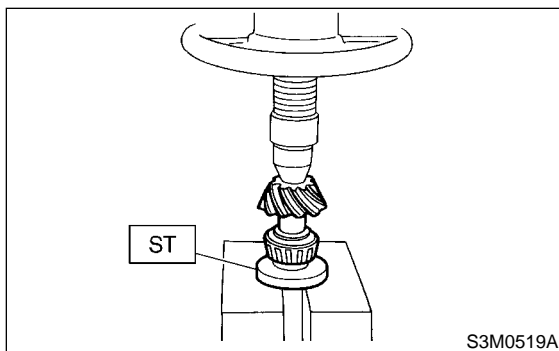

5) Insert drive pinion into differential carrier, install the previously selected bearing preload adjusting spacer and washer.

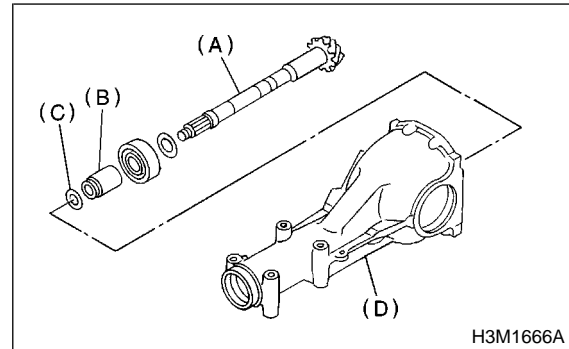

- (A) Drive pinion
- (B) Bearing preload adjusting spacer
- (C) Bearing preload adjusting washer
- (D) Differential carrier

6) Press-fit front bearing cone into carrier with ST1, ST2 and ST3.

ST1 32285AA000 DUMMY COLLAR

ST2 399780104 WEIGHT

ST3 899580100 INSTALLER

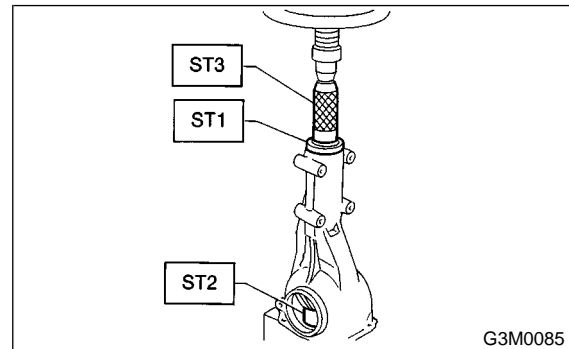

7) Insert spacer, then press-fit pilot bearing with ST1 and ST2.

ST1 399780104 WEIGHT

ST2 899580100 INSTALLER

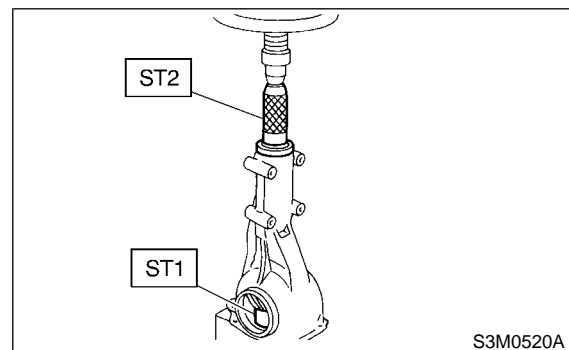

8) Fit a new oil seal with ST.

**NOTE:**

- Press-fit until end of oil seal is 1 mm (0.04 in) inward from end of carrier.
- Apply grease between the oil seal lips.

ST 498447120 OIL SEAL INSTALLER

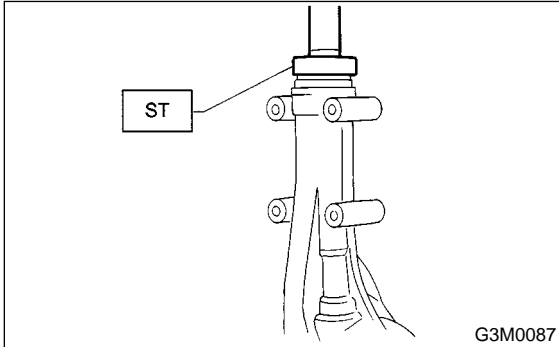

9) Press-fit companion flange with ST1 and ST2.

**CAUTION:**

**Be careful not to damage bearing.**

ST1 899874100 INSTALLER

ST2 399780104 WEIGHT

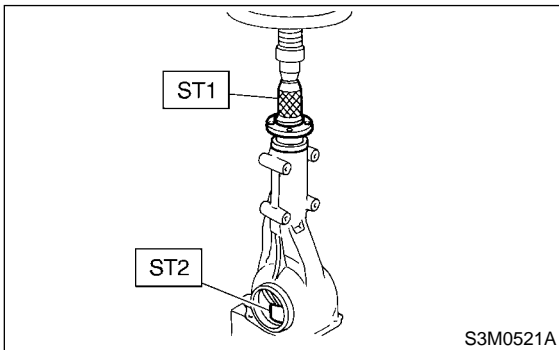

10) Install self-locking nut. Then tighten it with ST.

ST 398427200 FLANGE WRENCH

**Tightening torque:**

**188 N·m (19.2 kgf·m, 139 ft·lb)**

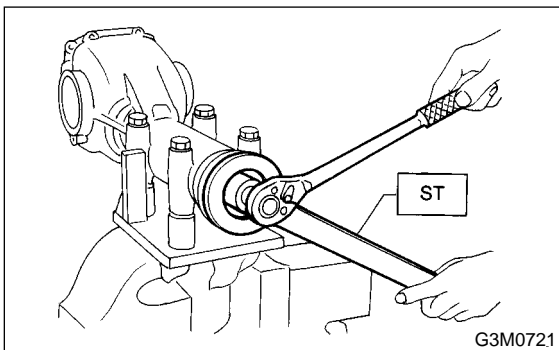

11) Assembling differential case

Install side gears and pinion mate gears, with their thrust washers and pinion mate shaft, into differential case.

**NOTE:**

- Apply gear oil on both sides of the washer and on the side gear shaft before installing.
- Insert the pinion mate shaft into the differential case by aligning the lock pin holes.

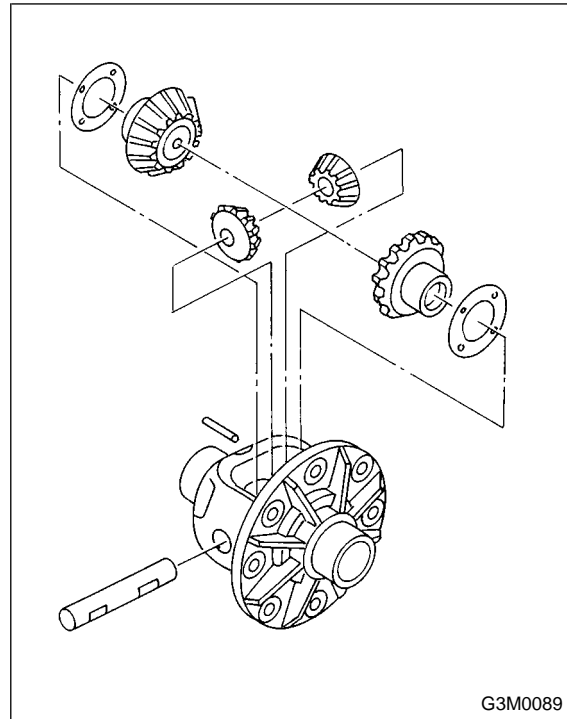

# REAR DIFFERENTIAL FOR VA-TYPE

## Differentials

(1) Measure the side gear backlash.

### Side gear back clearance:

**0.05 — 0.15 mm (0.0020 — 0.0059 in)**

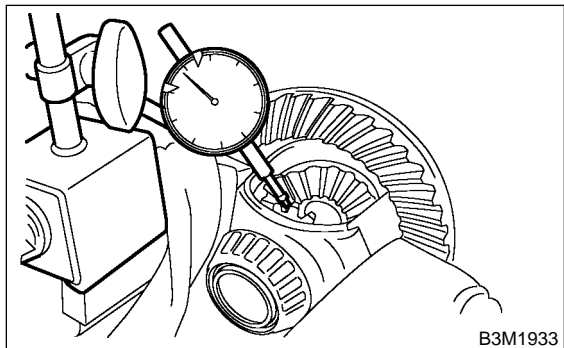

(2) Adjust the side gear backlash as specified by selecting side gear thrust washer.

Side gear thrust washer	
Part No.	Thickness mm (in)
803135011	0.925 — 0.950 (0.0364 — 0.0374)
803135012	0.950 — 0.975 (0.0374 — 0.0384)
803135013	0.975 — 1.000 (0.0384 — 0.0394)
803135014	1.000 — 1.025 (0.0394 — 0.0404)
803135015	1.025 — 1.050 (0.0404 — 0.0413)

(3) Check the condition of rotation after applying oil to the gear tooth surfaces and thrust surfaces.

(4) After driving in pinion shaft lock pin, stake the both sides of the hole to prevent pin from falling off.

(5) Install crown gear on differential case.

### CAUTION:

Before installing bolts, apply **Lock Tite** to bolt threads.

### Lock Tite

**THREE BOND 1324 or equivalent**

### NOTE:

Tighten diagonally while tapping the bolt heads.

### Tightening torque:

**62 N·m (6.3 kgf·m, 45.6 ft·lb)**

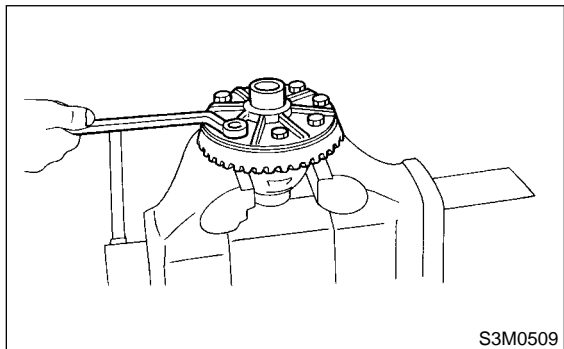

12) Press side bearing cone onto differential case with ST.

ST 498485400 DRIFT

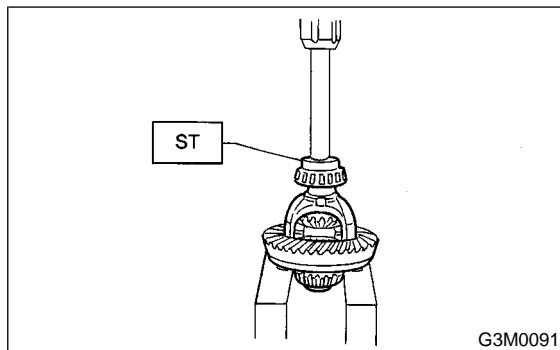

13) Assemble holders.

(1) Install oil seal into right and left holders.

ST 498447100 INSTALLER

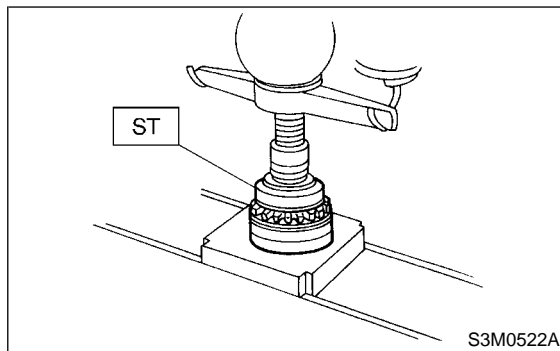

(2) Install bearing race into right and left holders.

ST 398477702 DRIFT

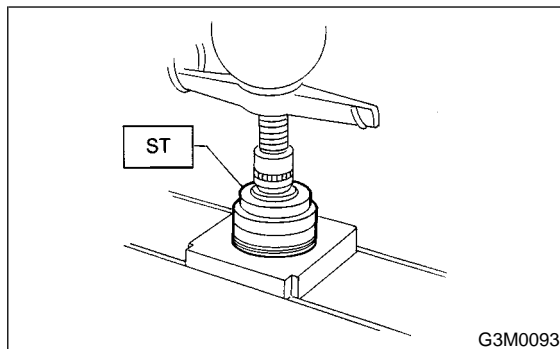

(3) Install the differential case assembly into differential carrier in the reverse order of disassembly.

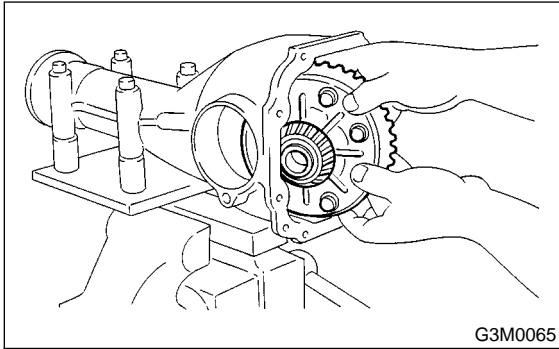

14) Perform adjustment of backlash of pinion crown gear set and adjustment of preload of differential side bearing.

(1) Turn drive pinion with ST for better fitting of differential side bearing.  
ST 498427200 FLANGE WRENCH

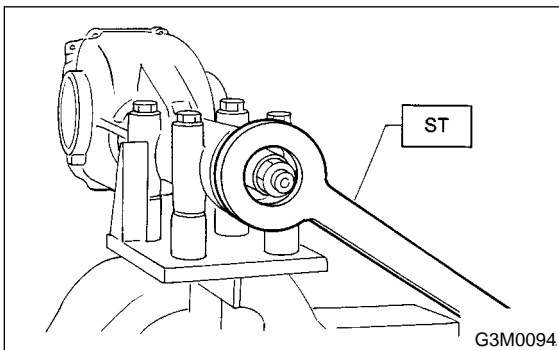

(2) Screw in side (left-side) holder until light contact is made with ST.  
ST 399780111 WRENCH

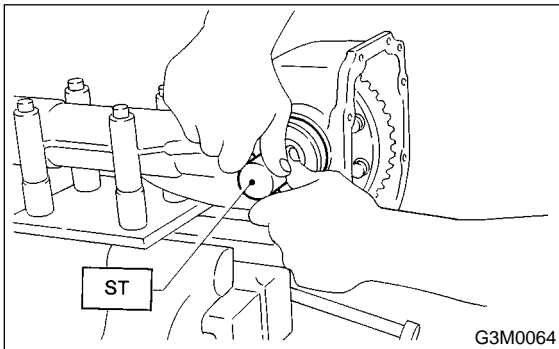

(3) Back off side (left-side) holder approximately 1 1/2 teeth of holder, and tighten left-side holder by approximately 2 teeth (approximately 1 1/2 + 1/2 teeth).

[Back off amount of side (left-side) holder + 1/2 tooth.]  
This + 1/2 tooth gives preload.

(4) Temporarily tighten lock plate.

NOTE:  
Turn over lock plate to displace holder 1/2 tooth.

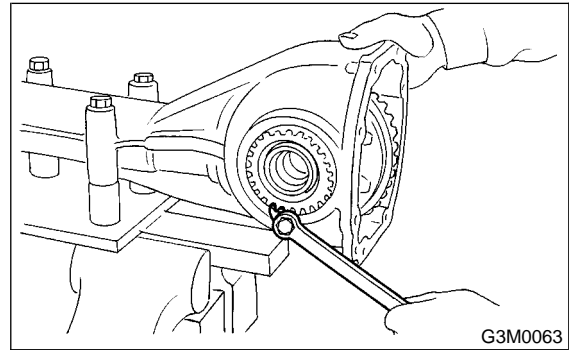

(5) Measure the crown gear-to-drive pinion backlash. Set magnet base on differential carrier. Align contact point of dial gauge with tooth face of crown gear, and move crown gear while holding drive pinion still. Read value indicated on dial gauge.

NOTE:  
If measured backlash is not within specified range, repeat procedures for pinion crown gear set backlash adjustment and differential side bearing preload adjustment.

**Backlash:**  
**0.10 — 0.15 mm (0.0039 — 0.0059 in)**

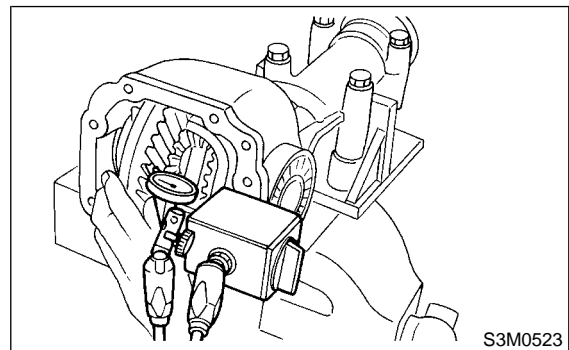

# REAR DIFFERENTIAL FOR VA-TYPE

## Differentials

15) Draw a matching mark on both differential carrier and holder. Remove holder one side at a time. Replace in the original position after inserting an O-ring and applying grease to threaded portion.

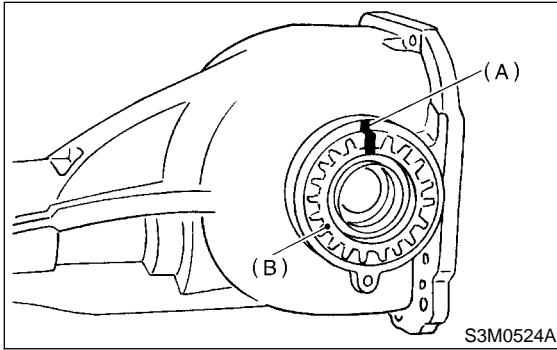

- (A) Matching mark
- (B) Holder

16) Tighten bolt of lock plate to specified torque.

### Tightening torque:

**25 N·m (2.5 kgf·m, 18.1 ft·lb)**

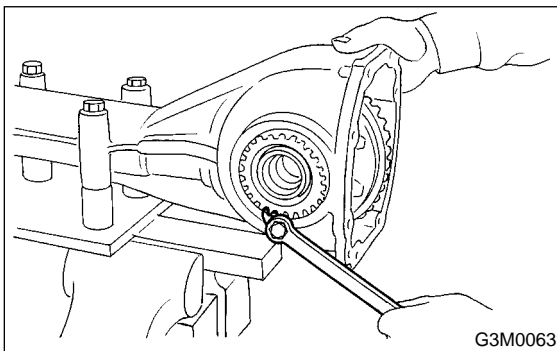

17) Re-check crown gear-to-pinion backlash.

### Backlash:

**0.10 — 0.15 mm (0.0039 — 0.0059 in)**

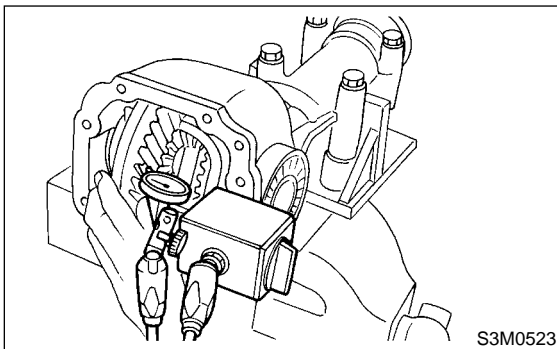

18) Check the crown gear runout on its back surface, and make sure pinion and crown gear rotate smoothly.

### Limit of runout:

**0.05 mm (0.0020 in)**

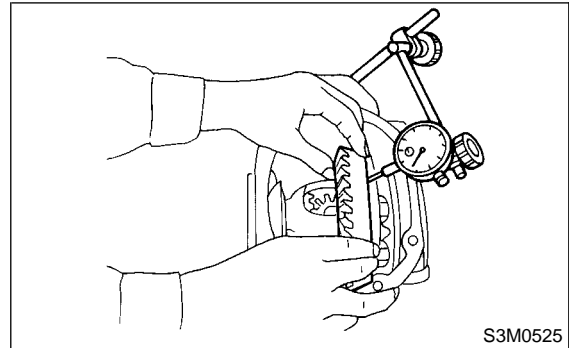

19) Checking and adjusting tooth contact of crown gear.

(1) Apply an even coat of red lead on both sides of three or four teeth on the crown gear. Check the contact pattern after rotating crown gear several revolutions back and forth until a definite contact pattern appears on the crown gear.

(2) When the contact pattern is incorrect, readjust according to the instructions given in "TOOTH CONTACT PATTERN".

### NOTE:

Be sure to wipe off red lead completely after adjustment is completed.

20) If proper tooth contact is not obtained, once again adjust the drive pinion height and the differential side bearing preload (already mentioned) and the hypoid gear backlash.

(1) Drive pinion height

ST1 498447150 DUMMY SHAFT

ST2 498505501 DIFFERENTIAL GAUGE

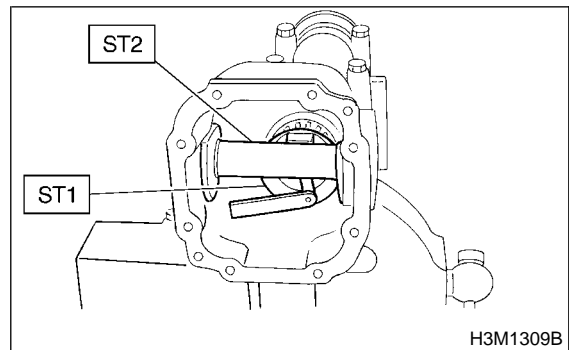

$$T = T_o + N - 0.05 \text{ (mm)}$$

where

T = Thickness of pinion height adjusting shim (mm)

T<sub>o</sub> = Thickness of shim originally installed (mm)

N = Reading of thickness gauge (mm)

(2) Differential side bearing preload  
Screw in side (left-side) holder until light contact is made with ST.

Back off side (left-side) holder approximately 1 1/2 teeth of holder, and tighten left-side holder by approximately 2 teeth (approximately 1 1/2 + 1/2 teeth).

[Back off amount of side (left-side) holder + 1/2 tooth.]

This + 1/2 tooth gives preload.

ST 399780111 WRENCH

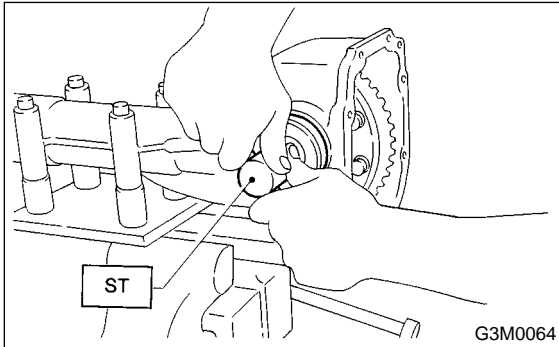

(3) Hypoid gear backlash

**Backlash:**

**0.10 — 0.15 mm (0.0039 — 0.0059 in)**

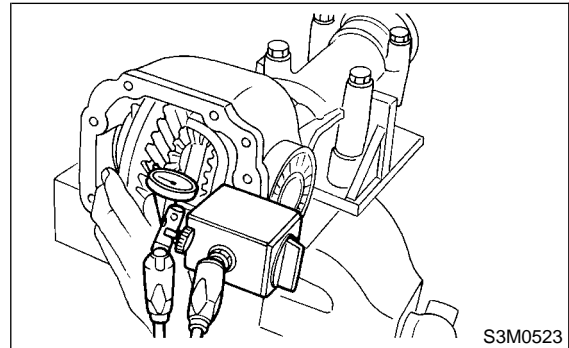



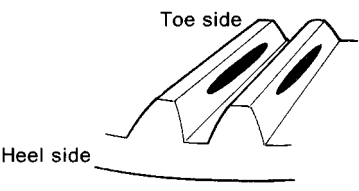
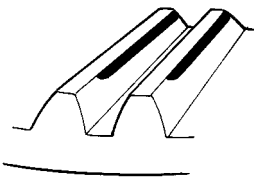
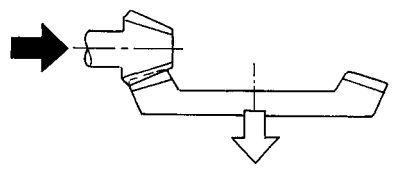
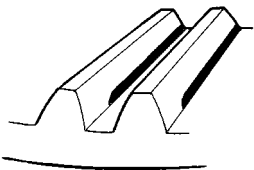
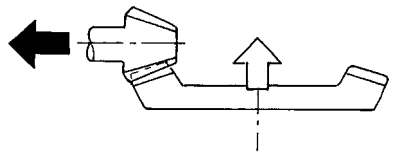
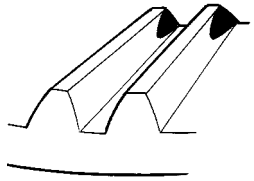
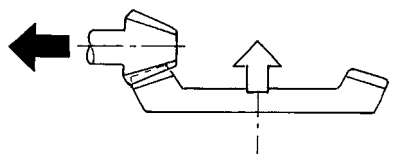
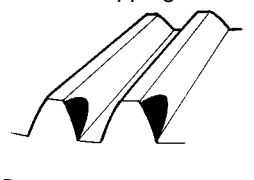
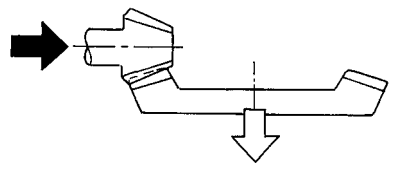

# REAR DIFFERENTIAL FOR VA-TYPE

Differentials

TOOTH CONTACT PATTERN		
Condition	Contact pattern	Adjustment
<p>Correct tooth contact Tooth contact pattern slightly shifted towards toe under no load rotation. (When loaded, contact pattern moves toward heel.)</p>	<p>Toe side</p>  <p>Heel side</p> <p style="text-align: right;">G3M0098A</p>	<p>—</p>
<p>Face contact Backlash is too large.</p>	<p>This may cause noise and chipping at tooth ends.</p>  <p style="text-align: right;">G3M0098B</p>	<p>Increase thickness of drive pinion height adjusting washer in order to bring drive pinion closer to crown gear center.</p>  <p style="text-align: right;">G3M0098F</p>
<p>Flank contact Backlash is too small.</p>	<p>This may cause noise and stepped wear on surfaces.</p>  <p style="text-align: right;">G3M0098C</p>	<p>Reduce thickness of drive pinion height adjusting washer in order to move drive pinion away from crown gear center.</p>  <p style="text-align: right;">G3M0098G</p>
<p>Toe contact</p>	<p>Contact area is small. This may cause chipping at toe ends.</p>  <p style="text-align: right;">G3M0098D</p>	<p>Adjust as for flank contact.</p>  <p style="text-align: right;">G3M0098G</p>
<p>Heel contact</p>	<p>Contact area is small. This may cause chipping at heel ends.</p>  <p style="text-align: right;">G3M0098E</p>	<p>Adjust as for face contact.</p>  <p style="text-align: right;">G3M0098F</p>

 : Adjusting direction of drive pinion  
 : Adjusting direction of crown gear

21) Install rear cover and tighten bolts to specified torque.

**Tightening torque:**

**25 N·m (2.5 kgf·m, 18.1 ft·lb)**

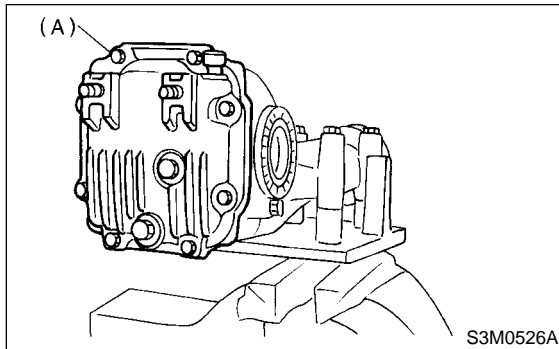

(A) Rear cover

## E: INSPECTION

S303151A10

Wash all the disassembled parts clean, and examine them for wear, damage, or other defects. Repair or replace defective parts as necessary.

1) Crown gear and drive pinion

- If abnormal tooth contact is evident, find out the cause and adjust to give correct tooth contact at assembly. Replace the gear if excessively worn or incapable of adjustment.

- If crack, score, or seizure is evident, replace as a set. Slight damage of tooth can be corrected by oil stone or the like.

2) Side gear and pinion mate gear

- Replace if crack, score, or other defects are evident on tooth surface.

- Replace if thrust washer contacting surface is worn or seized. Slight damage of the surface can be corrected by oil stone or the like.

3) Bearing

Replace if seizure, peeling, wear, rust, dragging during rotation, abnormal noise or other defect is evident.

4) Thrust washers of side gear and pinion mate gear

Replace if seizure, flaw, abnormal wear or other defect is evident.

5) Oil seal

Replace if deformed or damaged, and at every disassembling.

6) Differential carrier

Replace if the bearing bores are worn or damaged.

7) Differential case

Replace if its sliding surfaces are worn or cracked.

8) Companion flange

Replace if the oil seal lip contacting surfaces have flaws.

## 1. SIDE GEAR BACKLASH

S303151A1001

Using a dial gauge, check the backlash of the side gear.

**Side gear backlash:**

**0.05 — 0.15 mm (0.0020 — 0.0059 in)**

If side gear backlash is not within the specification, adjust clearance as specified by selecting side gear trust washer.

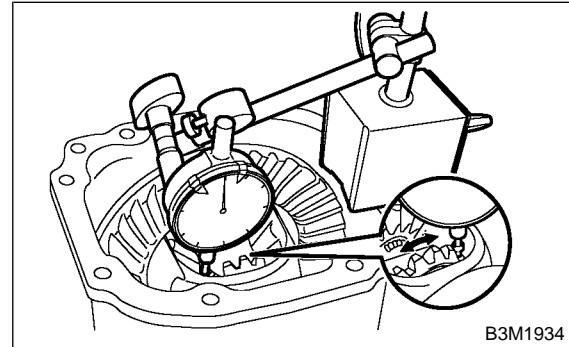

## 2. CROWN GEAR BACKLASH

S303151A1002

Using a dial gauge, check the backlash of the crown gear.

**Crown gear backlash:**

**0.10 — 0.15 mm (0.0039 — 0.0059 in)**

If crown gear backlash is not within the specification, adjust the side bearing preload or repair if necessary.

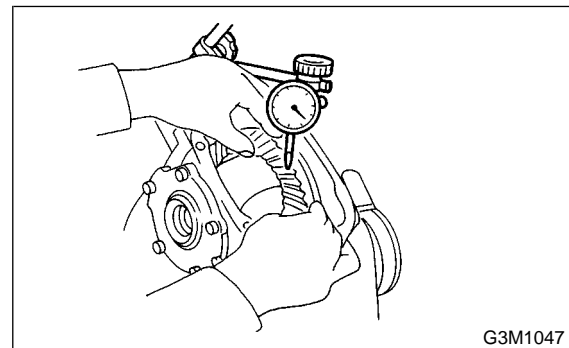

# REAR DIFFERENTIAL FOR VA-TYPE

Differentials

## 3. CROWN GEAR RUNOUT S303151A1003

Using a dial gauge, check the crown gear runout.

**Crown gear runout:**

**Less than 0.05 mm (0.0020 in)**

If the crown gear runout exceeds 0.05 mm (0.0020 in), replace the crown gear.

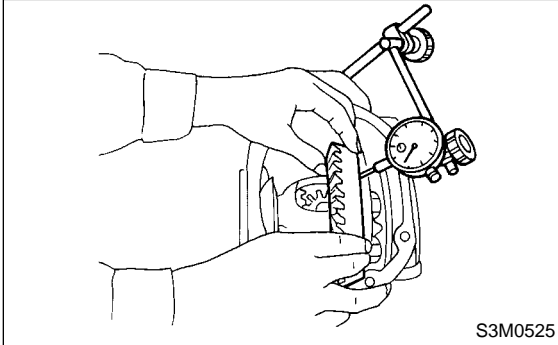

## 4. TOOTH CONTACT BETWEEN CROWN GEAR AND DRIVE PINION S303151A1004

Inspect tooth contact between crown gear and drive pinion.

<Ref. to DI-47 ASSEMBLY Rear Differential for VA-type.>

## F: ADJUSTMENT S303151A01

### 1. SIDE GEAR BACKLASH A303151A0101

Adjust side gear backlash.

<Ref. to DI-47 ASSEMBLY Rear Differential for VA-type.>

### 2. CROWN GEAR BACKLASH A303151A0102

Adjust crown gear backlash.

<Ref. to DI-47 ASSEMBLY Rear Differential for VA-type.>

### 3. TOOTH CONTACT BETWEEN CROWN GEAR AND DRIVE PINION A303151A0103

Adjust the tooth contact between crown gear and drive pinion gear.

<Ref. to DI-47 ASSEMBLY Rear Differential for VA-type.>

## 6. Rear Differential Front Oil Seal

S303139

### A: INSPECTION

S303139A10

Check front oil seal portion for oil leakage, if any leak is found, replace the oil seal and inspect propeller shaft.

### B: REPLACEMENT

S303139A20

- 1) Set vehicle on a lift.
- 2) Disconnect ground cable from battery.
- 3) Move select lever or gear shift lever to "N".
- 4) Release the parking brake.
- 5) Lift the vehicle.
- 6) Remove oil drain plug, and drain gear oil.

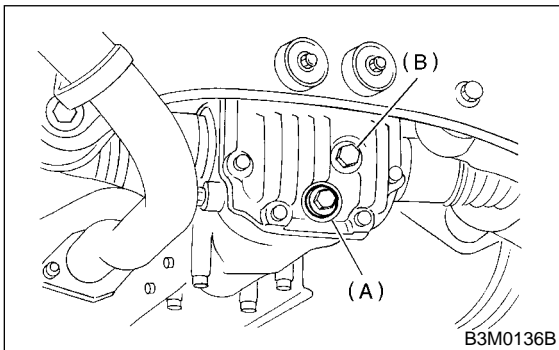

- (A) Drain plug  
(B) Filler plug

- 7) Install oil drain plug.

#### CAUTION:

- Apply fluid packing to drain plug in T-type.
- VA-type uses a new aluminum gasket.

#### Tightening torque:

##### T-type;

**49 N·m (5.0 kgf-m, 36.2 ft-lb)**

##### VA-type;

**34 N·m (3.5 kgf-m, 25.3 ft-lb)**

- 8) Remove rear exhaust pipe and muffler.
- 9) Remove propeller shaft from body. <Ref. to DS-17 REMOVAL, Propeller Shaft.>

- 10) Remove self-locking nut while holding companion flange with ST.

ST 498427200 FLANGE WRENCH

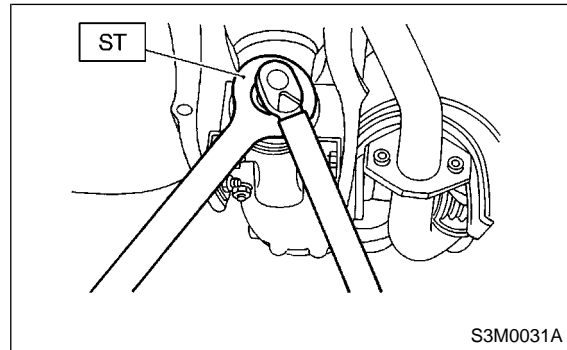

- 11) Extract companion flange using ST.

ST 399703600 PULLEY ASSY

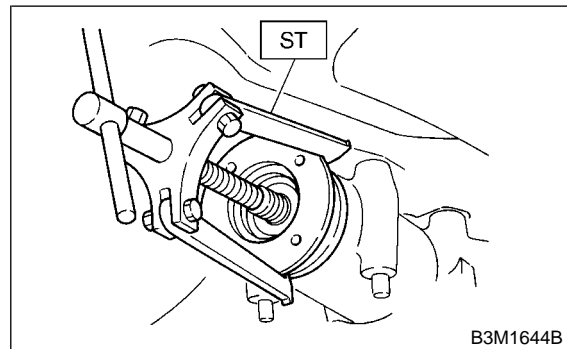

- 12) Remove oil seal using ST.

ST 499705401 PULLER ASSY

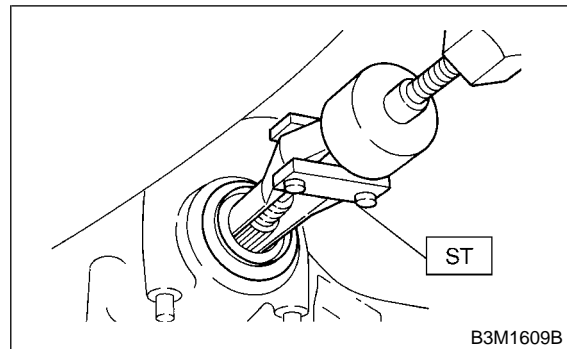

- 13) Fit a new oil seal using ST.

ST 498447120 OIL SEAL INSTALLER

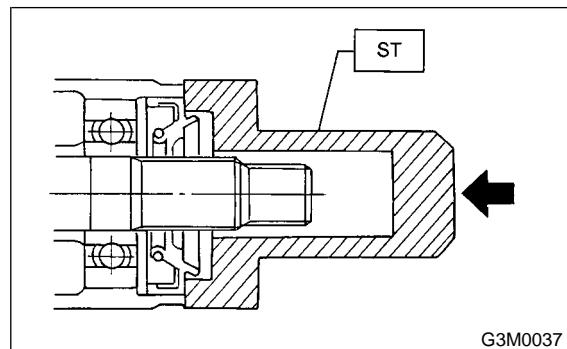

- 14) Install companion flange.

## REAR DIFFERENTIAL FRONT OIL SEAL

### Differentials

---

#### NOTE:

Use a plastic hammer to install companion flange.

15) Tighten self-locking nut within the specified torque range so that the turning resistance of companion flange becomes the same as that before replacing oil seal.

ST 498427200 FLANGE WRENCH

#### CAUTION:

Use a new self-locking nut.

#### Tightening torque:

**181.4 N-m (18.50 kgf-m, 133.8 ft-lb)**

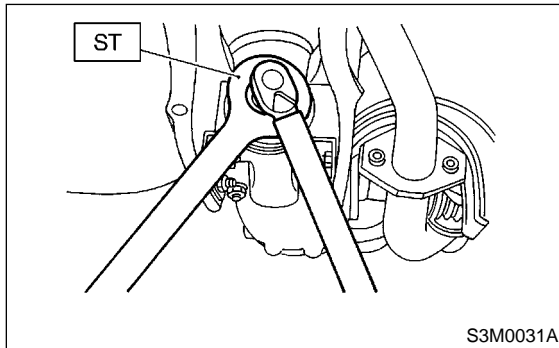

16) Install in the reverse order of removal.

17) Fill differential carrier with gear oil. <Ref. to DI-22 Differential Gear Oil.>

## 7. Rear Differential Side Oil Seal

S303137

### A: INSPECTION

S303137A10

Check side oil seal portion for oil leakage, if any leak is found, replace the side oil seal and inspect propeller shaft.

### B: REPLACEMENT

S303137A20

#### 1. VA-TYPE

S303137A2002

- 1) Set vehicle on a lift.
- 2) Disconnect ground terminal from battery.
- 3) Move select lever or gear shift lever to "N".
- 4) Release the parking brake.
- 5) Loosen both wheel nuts.
- 6) Jack-up the vehicle and support it with rigid racks.
- 7) Remove wheels.
- 8) Remove rear exhaust pipe and muffler.

With OBD:

<Ref. to EX(SOHC)-9, REMOVAL, Rear Exhaust Pipe.> and <Ref. to EX(SOHC)-11, REMOVAL, Muffler.>

Without OBD:

<Ref. to EX(SOHCw/oOBD)-10, REMOVAL, Rear Exhaust Pipe.> and <Ref. to EX(SOHCw/oOBD)-12, REMOVAL, Muffler.>

- 9) Remove the DOJ of rear drive shaft from rear differential.

- (1) Remove the ABS sensor cable clamp and parking brake cable guide from bracket.

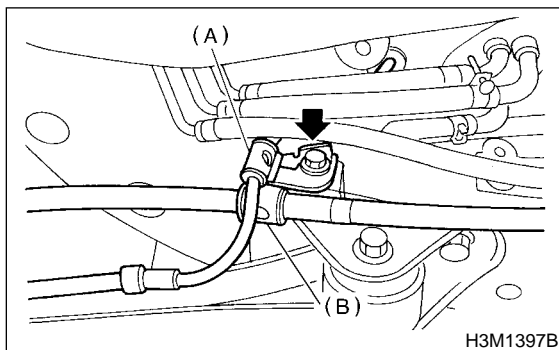

- (A) ABS sensor cable clamp
- (B) Parking brake cable guide

- (2) Remove the ABS sensor cable clamp from the trailing link.

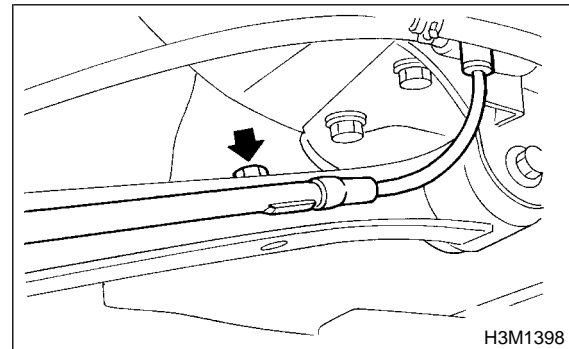

- (3) Remove the ABS sensor cable clamp and parking brake cable guide from the trailing link.

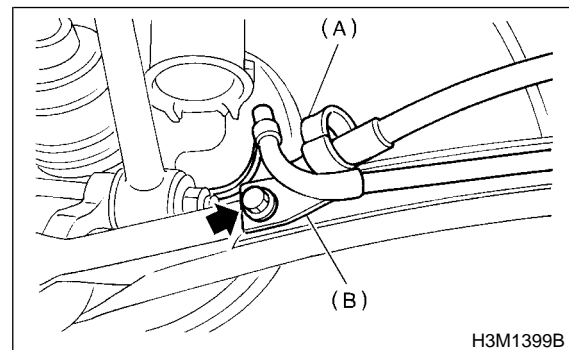

- (A) Parking brake cable guide
- (B) ABS sensor cable clamp

- (4) Remove the rear stabilizer link.

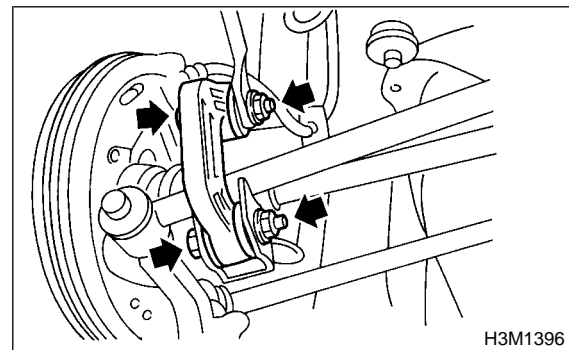

- (5) Remove the bolts which secure the trailing link to the rear housing.

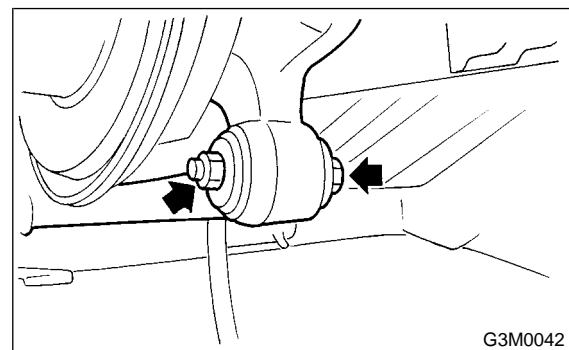

# REAR DIFFERENTIAL SIDE OIL SEAL

## Differentials

(6) Remove the bolts which secure the front and rear lateral link to the rear housing.

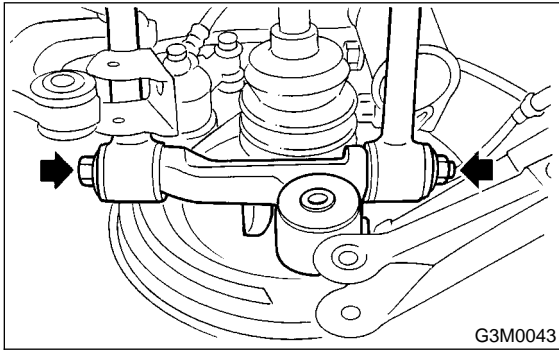

(7) Remove the DOJ from the rear differential with tire lever.

### CAUTION:

When removing the DOJ from the rear differential, fit tire lever to the bolt as shown in figure so as not to damage the axle shaft holder.

### NOTE:

The side spline shaft circlip comes out together with the shaft.

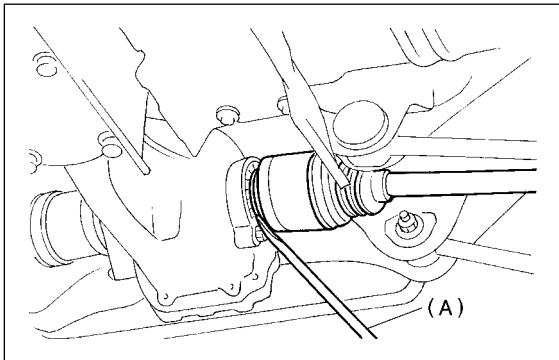

- (A) Tire lever
- (B) Axle shaft holder

10) Secure rear drive shaft to rear crossmember using wire.

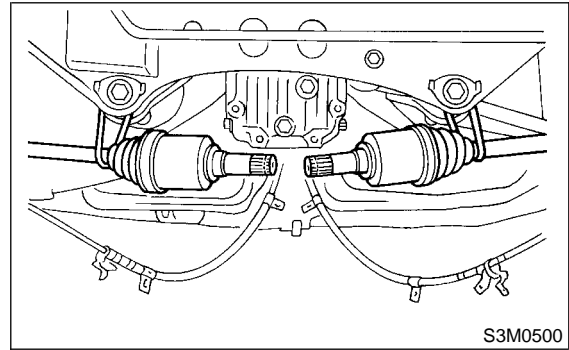

11) Remove oil seal with screwdriver.

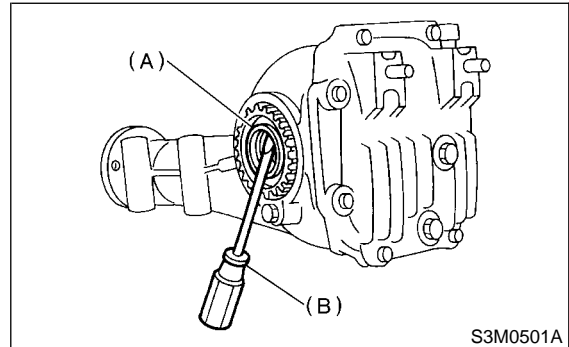

- (A) Side oil seal
- (B) Screwdriver

12) Drive in a new side oil seal with ST.

### CAUTION:

Apply chassis grease between the oil seal lips.  
ST 498447100 OIL SEAL INSTALLER

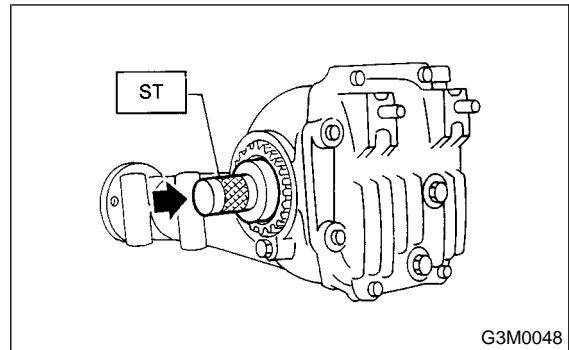

13) Insert the DOJ into rear differential.

### CAUTION:

Before inserting, replace the circlip at the end of the spline shaft with a new one.

- (1) Install ST to rear differential.  
**ST 28099PA090 SIDE OIL SEAL PROTECTOR**

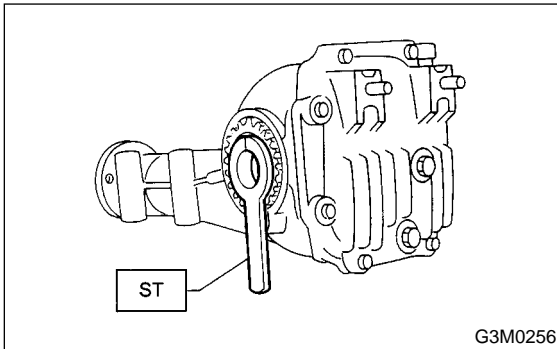

- (2) Insert the spline shaft until the spline portion is inside the side oil seal.

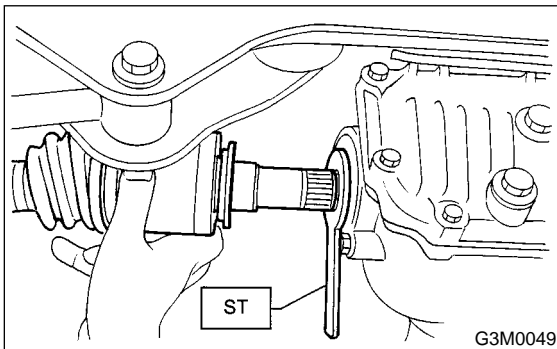

- (3) Remove ST.  
**ST 28099PA090 SIDE OIL SEAL PROTECTOR**

- (4) Completely insert DOJ into rear differential by pressing rear housing.

**NOTE:**  
 Make sure that oil seal lip is not folded over inward.

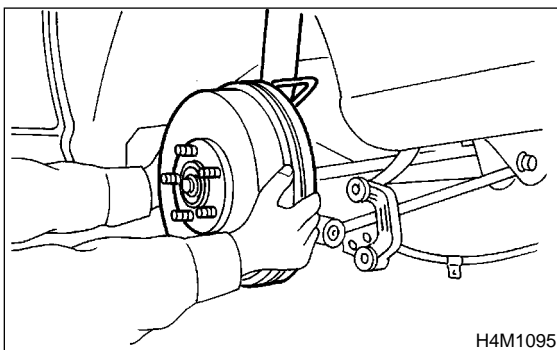

- 14) Install in the reverse order of removal.

## 2. T-TYPE S303137A2001

- 1) Set vehicle on a lift.
- 2) Disconnect ground terminal from battery.
- 3) Move select lever or gear shift lever to "N".
- 4) Release the parking brake.
- 5) Loosen both wheel nuts.

- 6) Jack-up the vehicle and support it with rigid racks.

- 7) Remove wheels.

- 8) Remove rear exhaust pipe and muffler.

Non-turbo model with OBD:

<Ref. to EX(SOHC)-9, REMOVAL, Rear Exhaust Pipe.> and <Ref. to EX(SOHC)-11, REMOVAL, Muffler.>

Non-turbo model without OBD:

<Ref. to EX(SOHCw/oOBD)-10, REMOVAL, Rear Exhaust Pipe.> and <Ref. to EX(SOHCw/oOBD)-12, REMOVAL, Muffler.>

Turbo model:

<Ref. to EX(DOHC TURBO)-14, REMOVAL, Rear Exhaust Pipe.> and <Ref. to EX(DOHC TURBO)-15, REMOVAL, Muffler.>

- 9) Remove the DOJ of rear drive shaft from rear differential.

- (1) Remove the ABS sensor cable clamp and parking brake cable guide from bracket.

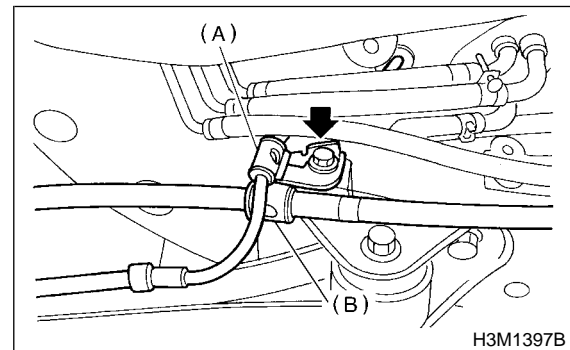

- (A) ABS sensor cable clamp  
 (B) Parking brake cable guide

- (2) Remove the ABS sensor cable clamp from the trailing link.

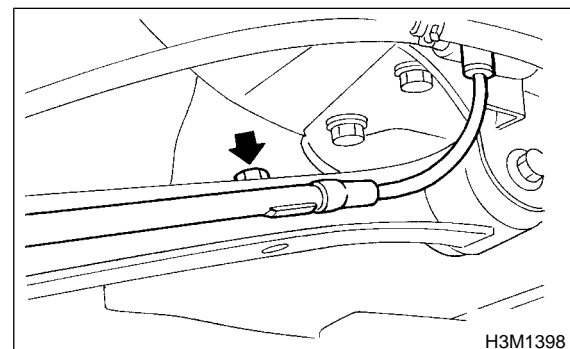



# REAR DIFFERENTIAL SIDE OIL SEAL

## Differentials

(3) Remove the ABS sensor cable clamp and parking brake cable guide from the trailing link.

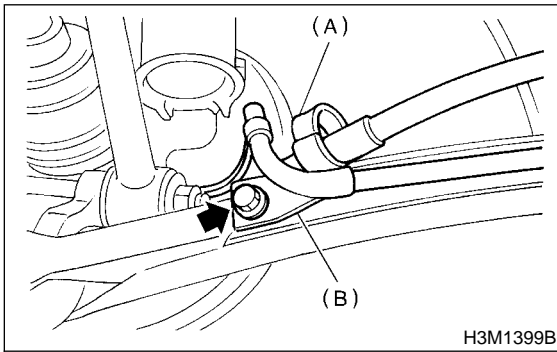

- (A) ABS sensor cable clamp
- (B) Parking brake cable guide

(4) Remove the rear stabilizer link.

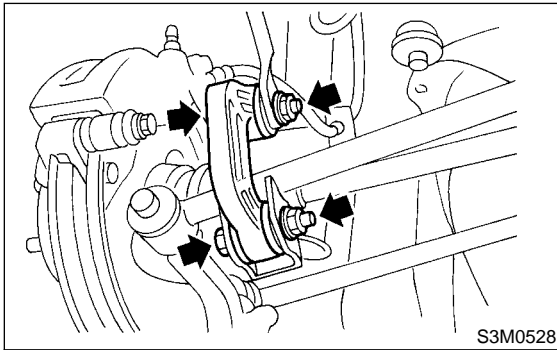

(5) Remove the bolts which secure the trailing link to the rear housing.

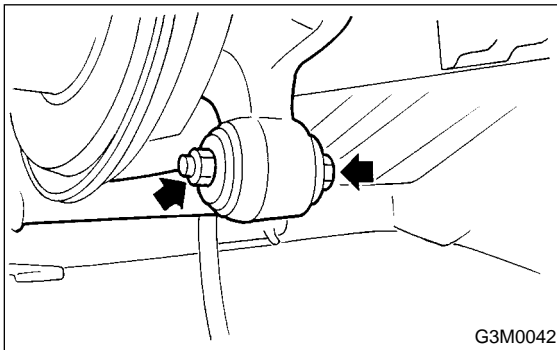

(6) Remove the bolts which secure the front and rear lateral link to the rear housing.

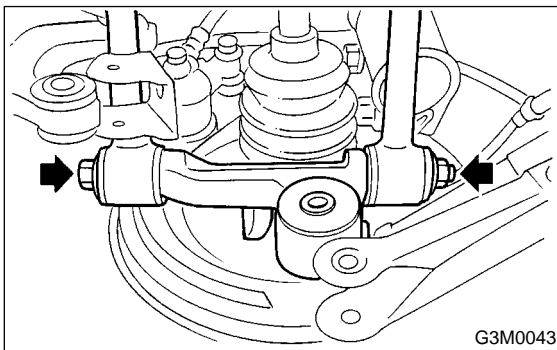

(7) Remove the DOJ from the rear differential by using ST.

**CAUTION:**  
When removing the DOJ from the rear differential, fit ST to the bolt as shown in figure so as not to damage the side bearing retainer.

ST 208099PA100 DRIVE SHAFT REMOVER

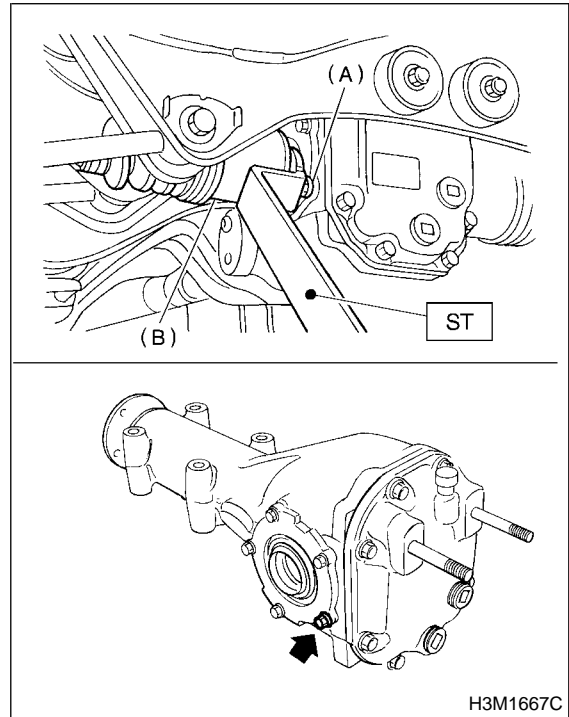

- (A) Bolt
- (B) DOJ

10) Secure rear drive shaft to rear crossmember using wire.

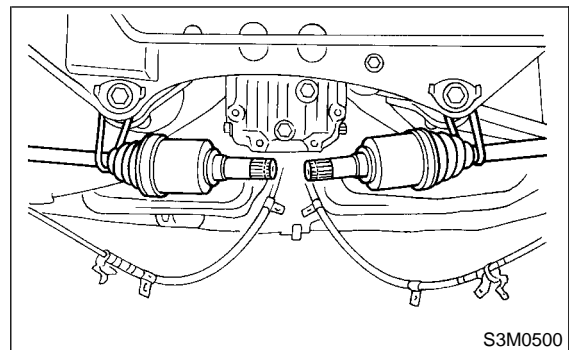

# REAR DIFFERENTIAL SIDE OIL SEAL

Differentials

- 11) Remove side oil seal with ST.  
ST 398527700 PULLER ASSY

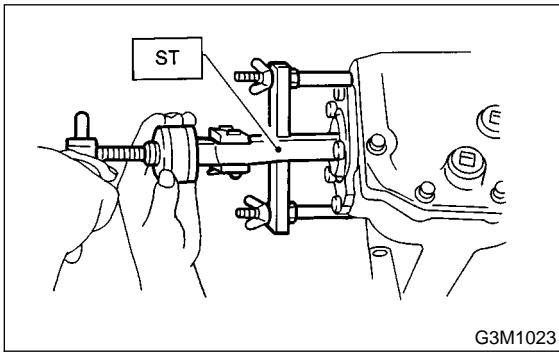

- 12) Drive in a new side oil seal with ST.

**CAUTION:**

**Apply chassis grease between the oil seal lips.**

- ST 398437700 DRIFT

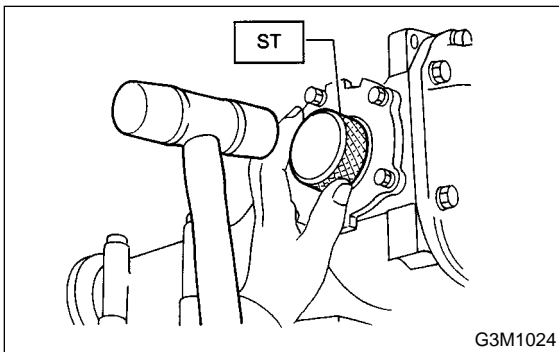

- 13) Insert the DOJ into rear differential.

- (1) Install ST to rear differential.

- ST 28099PA090 SIDE OIL SEAL PROTECTOR

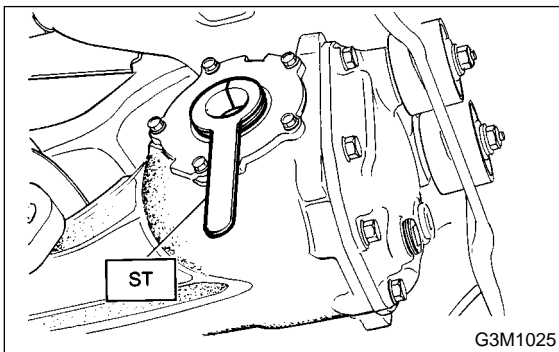

- (2) Insert the spline shaft until the spline portion is inside the side oil seal.

- (3) Remove ST.  
ST 28099PA090 SIDE OIL SEAL PROTECTOR

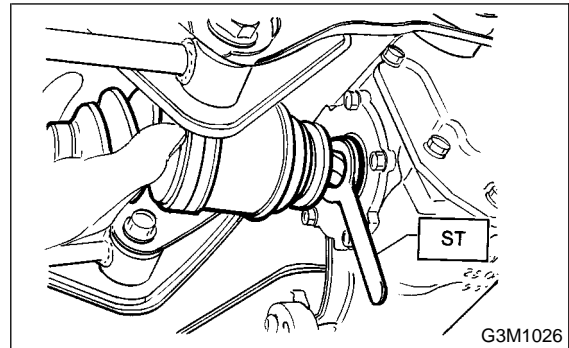

- (4) Completely insert DOJ into rear differential by pressing rear housing.

**NOTE:**

Make sure that oil seal lip is not folded over inward.

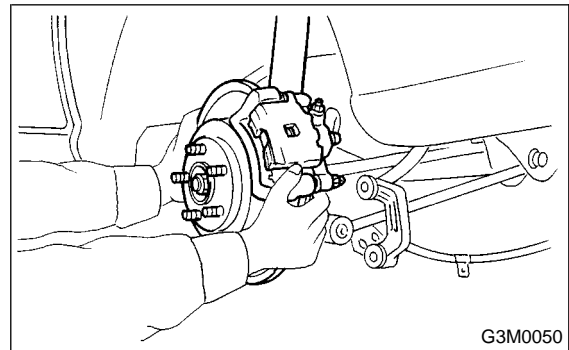

- 14) Install in the reverse order of removal.

## 8. Rear Differential Member S303135

### A: REMOVAL S303135A18

- 1) Set vehicle on a lift.
- 2) Disconnect ground terminal from battery.
- 3) Move select lever or gear shift lever to "N".
- 4) Release the parking brake.
- 5) Loosen wheel nuts.
- 6) Jack-up vehicle and support it with sturdy racks.
- 7) Remove wheels.
- 8) Remove rear exhaust pipe and muffler.

Non-turbo model with OBD:

<Ref. to EX(SOHC)-9, REMOVAL, Rear Exhaust Pipe.> and <Ref. to EX(SOHC)-11 REMOVAL, Muffler.>

Non-turbo model without OBD:

<Ref. to EX(SOHCw/oOBD)-10, REMOVAL, Rear Exhaust Pipe.> and <Ref. to EX(SOHCw/oOBD)-12, REMOVAL, Muffler.>

Turbo model:

<Ref. to EX(DOHC TURBO)-14, REMOVAL, Rear Exhaust Pipe.> and <Ref. to EX(DOHC TURBO)-15, REMOVAL, Muffler.>

- 9) Remove rear differential front member.

VA-type:

<Ref. to DI-42, REMOVAL, Rear Differential for VA-type.>

T-type:

<Ref. to DI-25, REMOVAL, Rear Differential for T-type.>

NOTE:

When removing rear differential front member, work the removal procedure as rear differential.

### B: INSTALLATION S303135A11

To install, reverse the removal sequence.

- 1) Position front member on body by passing it under parking brake cable and securing to rear differential.

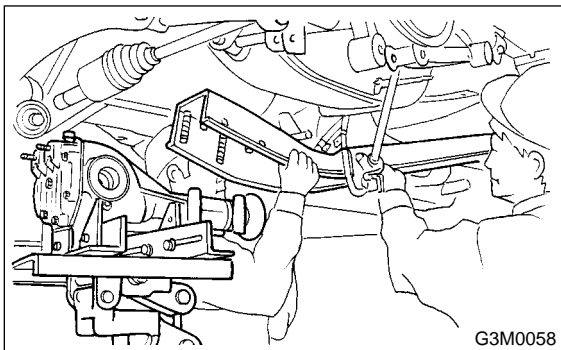

NOTE:

When installing rear differential front member, do not confuse the installation sequence of the stopper.

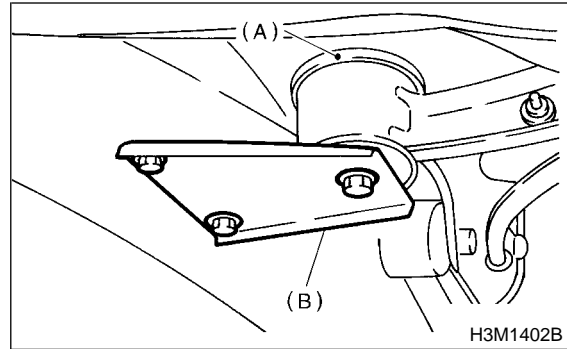

- (A) Stopper  
(B) Differential mount bracket

- 2) Insert DOJ of rear drive shaft into rear differential.

ST 28099PA090 SIDE OIL SEAL PROTECTOR

**CAUTION:**

**Before inserting, replace the differential side oil seal and the circlip at the end of the spline shaft with a new one.**

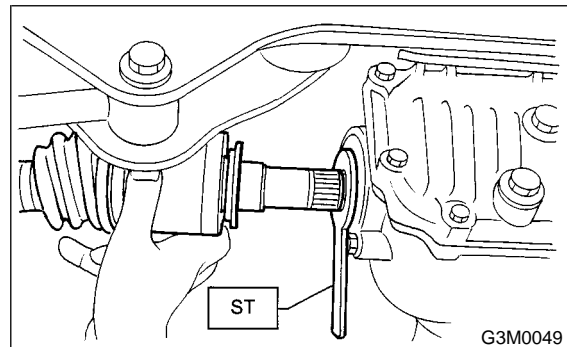

- 3) Install in the reverse order of removal.

### C: INSPECTION S303135A10

- 1) Check rear differential member for damage, bend, or corrosion.

If damage, bend, or corrosion is excessive, replace rear differential member.

- 2) Check bushings of rear differential member for cracking, hardening, or damage.

If cracking, hardening, or damage is excessive, replace rear differential member.

9. General Diagnostic Table S303257

A: INSPECTION S303257A10

Symptom or trouble	Possible cause	Remedy
<b>1. Oil leakage</b>	Worn, scratched, or incorrectly seated front or side oil seal. Scored, battered, or excessively worn sliding surface of companion flange.	Repair or replace.
	Clogged or damaged air breather.	Clean, repair or replace.
	Loose bolts on differential spindle or side retainer, or incorrectly fitted O-ring.	Tighten bolts to specified torque. Replace O-ring.
	Loose rear cover attaching bolts or damaged gasket.	Tighten bolts to specified torque. Replace gasket and apply liquid packing.
	Loose oil filler or drain plug.	Retighten and apply liquid packing.
	Wear, damage or incorrectly fitting for spindle, side retainer and oil seal.	Repair or replace.
<b>2. Seizure</b> NOTE: Seized or damaged parts should be replaced, and also other parts should be thoroughly checked for any defect and should be repaired or replaced as required.	Insufficient backlash for hypoid gear.	Readjust or replace.
	Excessive preload for side, rear, or front bearing.	Readjust or replace.
	Insufficient or improper oil used.	Replace seized part and fill with specified oil to specified level.
<b>3. Damage</b> NOTE: Damaged parts should be replaced, and also other parts should be thoroughly checked for any defect and should be repaired or replaced as required.	Improper backlash for hypoid gear.	Replace.
	Insufficient or excessive preload for side, rear, or front bearing.	Readjust or replace.
	Excessive backlash for differential gear.	Replace gear or thrust washer.
	Loose bolts and nuts such as crown gear bolt.	Retighten.
	Damage due to overloading.	Replace.
<b>4. Noises when starting or shifting gears</b> NOTE: Noises may be caused by differential assembly, universal joint, wheel bearing, etc. Find out what is actually making noise before disassembly.	Excessive backlash for hypoid gear.	Readjust.
	Excessive backlash for differential gear.	Replace gear or thrust washer.
	Insufficient preload for front or rear bearing.	Readjust.
	Loose drive pinion nut.	Tighten to specified torque.
	Loose bolts and nuts such as side bearing retainer attaching bolt.	Tighten to specified torque.
<b>5. Noises when cornering</b>	Damaged differential gear.	Replace.
	Excessive wear or damage of thrust washer.	Replace.
	Broken pinion mate shaft.	Replace.
	Seized or damaged side bearing.	Replace.
<b>6. Gear noises</b> NOTE: Since noises from engine, muffler, transmission, propeller shaft, wheel bearings, tires, and body are sometimes mistaken for noises from differential assembly, be careful in checking them. Inspection methods to locate noises include coasting, accelerating, cruising, and jacking-up all four wheels. Perform these inspections according to condition of trouble. When listening to noises, shift gears into four wheel drive and fourth speed position, trying to pick up only differential noise.	Improper tooth contact of hypoid gear.	Readjust or replace hypoid gear set.
	Improper backlash for hypoid gear.	Readjust.
	Scored or chipped teeth of hypoid gear.	Replace hypoid gear set.
	Seized hypoid gear.	Replace hypoid gear set.
	Improper preload for front or rear bearings.	Readjust.
	Seized, scored, or chipped front or rear bearing.	Replace.
	Seized, scored, or chipped side bearing.	Replace.
	Vibrating differential carrier.	Replace.

# GENERAL DIAGNOSTIC TABLE

Differentials

---

**MEMO:**