



# ***Compact 45/47 Owners Manual***

VERSION JAN 2015

# TABLE OF CONTENTS

## OPERATIONS

Table of Contents	1
Machine Data Log	2
Safety Instructions	3
Technical Specifications	5
General Information	6
- Local Water Conditions	
- Waste Water Disposal	
- Cleaning Solutions & Cleaning	
- Cleaning Wand Procedure	
Operating Instructions	7
- Start up	
- Shut down	
De-flooding	8
Freeze Guard Procedure	8
Water Flow System	8
High Pressure Pump	8
Vacuum System	9
Electrical System	9
Heat Exchangers	9
PTO System	9
Front Instrument Panel	9
Recovery Tank	9
Maintenance	10
- Daily	
- Weekly	
- Monthly	
- Quarterly	
- Bi-Annual	
- Coil Flush	
Troubleshooting	11
Water Pumping & Heat Transfer System	15
- Optional PTI	
- PTI Maintenance	
- PTI Operating System	
- Jet Sizing	
Chemical Injection System	19
Vacuum System	20
Vacuum Pump	21
- Water Pump	
- Vacuum Inlet Filter	
- Vacuum Relief Valve	
- Drive Belts	
- Pressure Regulator	
- Hoses	
- Optional Waste Pump-out	
Engine Coolant Replacement	23
- Water Pump Drive Belt	
- Waste Tank Lint Basket	
- Waste Tank Float Valve	
- Inline Water Filter	
Troubleshooting	24

## DRAWING & PARTS LIST

Front Panels	12
Water Pumping & Heat Transfer System	17
- With PTI Option	18
Chemical Injection System	19
Vacuum System	20
Overhead View - Dual Heat Exchanger	27
Overhead View – Electric Hose Reel	28
Front Panel – Front View	29
Front Panel – Back View	30
Front Panel – Plumbing Assembly	32
Pressure Regulator	35
Recovery Tank	36
BasePlate	38
Pump Kit	43
Installation Kit	44
Dual Heat Exchanger	48
P.T.I.	50
Cover & Holder Kit	52
PTO Shaft	54
CAD Panel Mount Option	56
CAD External Option	57
Horizontal F/W Tank	60
Aqua Storage F/W Tank	62
Electric Hose Reel Set	64
Aqua Reel	66
Wand 2 Jet	70
Wand Single Jet	71
Stair Tool 30" Swivel	72
Stair Tool 40"	73
Upholstery Tool 3"	74
Wand 1 3/4" S-Bend 4 Jet	75
Stair Tool 36" S-Bend	76

## WIRING

Wiring Diagrams	77
-----------------	----

## WARRANTY

5 Year Extend-A-Care Warranty	80
-------------------------------	----

## MACHINE DATA LOG/OVERVIEW

MODEL _____
DATE OF PURCHASE _____
SERIAL NUMBER _____
COMPANY NAME _____

<b>YOUR DEALER</b>	
NAME:	_____
ADDRESS:	_____
PHONE NUMBER:	_____

**Welcome...**and congratulations on the purchase of your Cleanco Truckmount. This instruction manual is a guide for operating and servicing your unit. **Read this manual completely before installing or operating this unit.** This unit offers you personal convenience. All of your instrumentation and controls have been positioned to give you easy access for operation and daily maintenance.

Proper operation and service are essential to the efficient functioning of this unit. When maintained correctly, this unit will have a long, trouble-free life.

The service methods described in this manual are explained in such a manner that servicing may be performed accurately and safely. Proper service varies with the choice of procedure, the skill of the mechanic, and the tools or parts available. Before attempting any repair, make certain that you are thoroughly familiar with this equipment and are equipped with the proper tools. Any questions pertaining to operating or servicing this unit should be directed to your nearest dealer.

***THIS UNIT MUST BE INSTALLED BY THE DEALER FROM WHOM YOU PURCHASED IT IN ACCORDANCE WITH THE PRESCRIBED INSTALLATION PROCEDURES.***

MAKE CERTAIN THAT THE WARRANTY FORM IS FILLED OUT AT THE TIME OF INSTALLATION AND IS RETURNED TO YOUR DEALER.

ESTEAM MANUFACTURING LTD  
3750 19<sup>TH</sup> ST. N.E  
CALGARY, ALBERTA, CANADA T2E 6V2

Information in this document is subject to change without notice and does not represent a commitment on the part of Esteam Manufacturing Ltd.

# IMPORTANT SAFETY INSTRUCTIONS

When using this machine, basic precautions must always be followed, including the following:

## READ ALL INSTRUCTIONS BEFORE USING THIS MACHINE



**These symbols mean WARNING or CAUTION. Failure to follow warnings and cautions could result in fatality, personal injury to yourself and/or others, or property damage. Follow these instructions carefully!**

**Read the operator's manual before installing or starting this unit.** Failure to adhere to instructions could result in severe personal injury or could be fatal.

**Operate this unit and equipment only in a well-ventilated area.** Exhaust fumes contain carbon monoxide which is an odorless and deadly poison that can cause severe injury or fatality. **DO NOT** run this unit in an enclosed area. **DO NOT** operate this unit where the exhaust may enter any building doorway, window, vent, or opening of any type.

**DO NOT** store any type of flammable material in the vehicle.

**DO NOT operate engine if gasoline is spilled.** Avoid creating any ignition until the gasoline has been cleaned up. Never use gasoline as a cleaning agent.

**DO NOT place hands, feet, hair, or clothing near rotating or moving parts.** Avoid any contact with moving parts! Rotating machinery can cause injury or fatality.

**Never operate this unit without belt guards or hoods.** The high speed moving parts, such as belts and pulleys, should be avoided while this unit is running. Severe injury, damage or fatality may result.

**DO NOT service this unit while it is running.** The high-speed mechanical parts as well as high temperature components may result in severe injury or severed limbs.

**Never touch electrical wires or components while the engine is running.** They can be sources of electrical shock.

**Before servicing this unit, allow it to "cool down."** This will prevent burns from occurring.

**Water under high pressure at high temperature can cause burns, severe personal injury or fatality. Shut down machine, allow to cool down, and relieve system of all pressure before removing valves, caps, plugs, fittings, filters, and bolts.**

**Always wear hearing protection when unit is running. Always comply with local noise ordinance when operating units.**

**Dangerous Acid, Explosive Gases!** Batteries contain sulfuric acid. To prevent acid burns, avoid contact with skin, eyes and clothing. Batteries produce explosive hydrogen gas while being charged. To prevent a fire or explosion, charge batteries only in well ventilated areas. Keep sparks, open flames, and other sources of ignition away from the battery at all times. Keep batteries out of the reach of children. Remove all jewelry when servicing batteries.

Before disconnecting the negative (-) ground cable, make sure all switches are OFF. If ON, a spark will occur at the ground cable terminal which could cause an explosion if hydrogen gas or gasoline vapors are present. When disconnecting the battery, **ALWAYS** disconnect the negative (-) terminal **FIRST**.

**DO NOT smoke around the unit.** Gas fumes may accumulate and be ignited. The battery is also extremely flammable. This will prevent possible explosions.

**DO NOT damage the vehicle in any manner during installation.** When routing fuel lines **DO NOT** place the hose in any location where damage may occur to the hose or vehicle. Avoid any contact with moving parts, areas of high temperature, brake lines, fuel lines, muffler, catalytic converter, or sharp objects.

**DO NOT exceed your vehicle's weight limit.** The console with waste tank and accessories weighs approximately 800 lbs. Make certain to account for any additional accessories in your weight and balance calculations. Make certain that the vehicle has the correct axle rating. This will prevent unsafe vehicle driving conditions.

**We require high-back seats on all vehicles in which units are to be installed for head and neck protection.** We recommend using a metal partition between the seats and equipment.

**DO NOT operate this unit without the water supply attachment turned on.** The water pump and other vital components may be seriously damaged if this unit is permitted to operate dry without water.

***DO NOT operate this unit without the filter installed in the waste tank.***

**Keep your vehicle work area clean.** Wands, stair tools, and other accessories must be securely fastened before driving the vehicle.

**All high pressure hoses must be rated for 3000 PSI at 250° F.** Thermoplastic hoses do not meet these specifications and should not be used. Severe burns and injury may result if the hoses do not meet these requirements.

**Make certain that you receive complete training by the distributor from whom you purchased this unit.**

**This unit uses high pressure and temperature. Improper or irresponsible use may result in serious injury.**

**Do not modify this unit in any manner.** Improper modification can cause severe personal injury or fatality.

## TECHNICAL SPECIFICATIONS

ITEM	DIMENSION/CAPACITY
Engine speed	1450 rpm (high speed) Water Pump ON
Water pump rpm	850 rpm
Vacuum pump rpm	2850 rpm
Water flow rate	4 GPM (maximum)
Water pump pressure	1200 PSI (maximum)
Vacuum relief valve	14" Hg/45 - 14" Hg/47
Waste tank capacity	100 gallons (optional 120 gallon)
Console weight (with waste tank)	500 lbs.

### JET SIZING:

Recommended **floor tool** tip sizing should not exceed a total of ".045". Using larger jet sizes on your cleaning unit may reduce cleaning temperatures.

**Example:**      **Dual-jet wand uses two 11001.5 jets** (110 deg spray angle w/ 01.5 orifice).  
                    **015 x 2 = 03**  
                    **Quad-jet wand uses four 9501 jets** (95 deg spray angle w/ 1.0 orifice)  
                    **01 x 4 = 04**

**Upholstery tool jet size:**                      **80015**  
**Stair tool jet size:**                              **9502**

## GENERAL INFORMATION

The Cleanco Compact Truckmount has been designed for the professional cleaner who demands a high performance cleaning unit. Dependable performance is the guiding principal in the design and construction of the Cleanco Compact. Although the Cleanco Compacts are designed with simplicity in mind, this truckmounted carpet cleaning plant has many functions that perform simultaneously.

- Engine has to run at a continuous RPM. (Van Engine 1450 RPM)
- High Pressure water pump provides steady pressure at the proper flow for cleaning.
- Vacuum Blower has to pull air and soiled water back from the site.
- Cleaning solution has to be injected into the water flow at the right concentration.
- Heating system must deliver and maintain proper heat.
- The vacuum recovery tank stores soiled water for proper disposal.

This manual contains operation instructions as well as information required for proper maintenance, adjustments, and repair of this unit. To assist with proper diagnosis of a problem, a general troubleshooting has been included for your convenience.

## LOCAL WATER CONDITIONS

The quality of water varies greatly throughout North America. This can influence the reliability and efficiency of your equipment. Many areas have an excess of minerals in the water, which results in what is known as hard water. These minerals tend to adhere to the inside of heat exchangers and other parts of the machines causing damage and loss of cleaning effectiveness.

Cleaning effectiveness and equipment life is increased when water softeners are used in hard water areas. The low cost of water softeners is more than made up for by the increased life of machine parts and cleaning efficiency.

## WASTE WATER DISPOSAL

There are laws throughout North America that prohibit the dumping of soiled water from carpet cleaning equipment in any place but a sanitary treatment system.

The water recovered into your unit's recovery tank contains materials such as detergent residue and many different soil contaminants removed from the carpet you

have cleaned. These materials must be processed before they are safe to re-enter our streams, rivers and reservoirs.

**AS PER FEDERAL, STATE AND LOCAL LAWS, DO NOT DISPOSE OF WASTE WATER INTO STORM DRAINS, GUTTERS, STREAMS, RESERVOIRS, ETC.**

## CLEANING SOLUTIONS & CLEANING

Your Cleanco Compact has been designed with the latest technology to produce the highest quality cleaning results possible. However it is only one of many tools of the carpet cleaning trade, and can produce only as good as the person operating it. There are no short cuts to quality. It takes time, cleaning knowledge, and the proper use of quality cleaning solutions.

Cleanco recommends Esteam Cleaning Systems brand name for use in your Cleanco Compact. Also be sure to follow directions of all cleaning solutions, to obtain quality results and for safety. The improper use of cleaning solutions in your Cleanco Compact can cause serious damage to the plumbing system, high-pressure pump, and heat exchangers. (Cleanco does not recommend running products through your unit such as solvents, or grease removers with a high concentration of solvents).

Cleanco endorses the IICRC Standards for Carpet Cleaning, which outlines proper cleaning procedures for all types of carpet and all kinds of cleaning systems. We encourage Cleanco owners to acquire a copy of these standards from your distributor and make yourself familiar with them. In brief, the standards specify that all carpet must be dry vacuumed, preconditioned, rinsed, and dried, in order to be properly cleaned.

## CLEANING WAND PROCEDURE

To have a quality cleaning result, correct wand movement is of the utmost importance. Failure to take time and extra care can result in an unhappy client.

Always move the cleaning wand in a smooth forward and backward motion. Apply slight pressure on the forward stroke while injecting cleaning solution onto the carpet. Then on the backstroke towards yourself again apply slight pressure on the wand and inject and vacuum cleaning solution. Continue this method over-lapping each forward and backstroke, for about a three to four foot square area. Once the three square foot area has been completed, return back over the same area-utilizing vacuum only. Moving across then clean and vacuum the next three to four square feet and again

repeating the extra vacuum pass. A good rule to remember is for every one wet pass, two dry (vacuum) passes are required. Failure to adopt good wandng procedures can result in streaking, over wetting, browning and longer drying times.

Over wetting not only leaves a bad impression with your client but may also require an extra trip back to correct annoying problems such as browning. There are several things that could cause over wetting:

1. Not enough vacuum strokes, or incorrect wandng procedures.
2. Clogged vacuum blower filter.
3. Clogged lint basket filter.
4. Vacuum tank not sealed properly.
5. Obstruction in the vacuum hose, or kink in the vacuum hose.
6. Vacuum tank drain valve partially open.
7. Cleaning a heavily foam-saturated carpet without defoamer.

## OPERATING INSTRUCTIONS

**NOTE:** Before operating the unit, make sure you are in a well-ventilated area. Exhaust fumes from the vehicle contain carbon monoxide and are hazardous to your health and your client's health. Do not operate the unit or the vehicle near any building doorways, windows, or openings of any kind.

1. Check your fuel gauge to ensure you have enough fuel for the job.
2. Check to make sure you have an adequate amount of fresh water in your fresh water tank to complete the entire job. If not, fill fresh water tank prior to starting the job.
3. Check your chemical jug to ensure that you have enough concentrated solution for the required job. If not, mix and fill the chemical jug with the desired cleaning solution.
4. Connect all hoses required. When connecting hoses start from the furthest point to be cleaned and work back towards the unit. This will ensure that you have the proper length required. Once at the Cleanco unit, connect the high-pressure hose to the quick discount on the front panel. Then repeat the same process with the vacuum hose and connect it to the vacuum port on top of the recovery tank.

## START UP

1. Make sure the van is in the park position and the emergency brake is set.
2. With the van engine running, turn the main power switch to UPHOLSTERY or CARPET MODE depending on the work you are about to do.

3. Connect the fill (primer) hose to the second high pressure quick connect on the instrument panel, and place the open end in the second vacuum port.
4. Turn on the high pressure pump switch to the "ON" position. (Water will start to flow through the fill (primer) hose into the recovery tank.)
5. Adjust the chemical metering system by turning the chemical metering knob counter clock wise until the float ball in the chemical meter sits at 2 or 3 GPH.
6. Turn the pump switch to the "OFF" position and disconnect the fill (primer) hose.
7. Turn the pump switch to the "ON" position and check the pressure setting on the high pressure gauge. Standard carpet cleaning pressures should be between 300 and 500 psi. Upholstery pressures should be between 100 and 200 psi.
8. Connect the vacuum and the male end of the pressure hose to the carpet wand or tool being used.
9. You are now ready to start cleaning.

**NOTE:** The machine will automatically shut down when it reaches full capacity due to the high level float switch located inside the recovery tank. When this occurs, empty the recovery tank at an approved disposal site. To save time on emptying recovery tanks Cleanco recommends that you have a Cleanco C.A.D. (Cleanco Auto Drain) installed on your recovery tank.

## SHUT DOWN

1. Lay vacuum hoses out in order for all moisture to be removed from hoses. This prevents spillage of any soiled water in your vehicle when storing hoses.
2. Turn the MAIN POWER SWITCH to the "OFF" position.
3. Turn the high pressure pump switch to the "OFF" position.
4. Disconnect all vacuum and high pressure hose and place them in the van. Also place the carpet wand and any tools that were on the job site into the van.
5. Remove the lift out lint basket, clean, and replace the lint basket back into the recovery tank.
6. Drain recovery tank at an approved disposal site.



## DE-FLOODING OPERATIONS

De-flooding operations involve removal of water from carpet and flooring. This differs from normal cleaning operations in that no water or solution is required. A Cleanco Auto Drain is recommended for all de-flooding operations due to the large amount of water removal often required.

1. Turn the MAIN POWER switch to the "CARPET MODE".
2. Leave pump switch "OFF" position.

## FREEZE GUARD PROCEDURE

1. Drain recovery and fresh water tanks.
2. Remove chemical jug and store in a heated area.
3. Remove hose from fresh water tank and insert into a container of window washer antifreeze along with the chemical feed hose.
4. Turn chemical flow meter knob to the on position.
5. Attach the fill (primer) hose to the front panel high pressure quick connect and place other end into an empty pail.
6. Turn the unit switch and pump switch to the on position.
7. Open the ball valve on the fill (primer) hose.
8. Chemical flow meter will begin to draw antifreeze into the chemical injection system, continue until all water is evacuated and antifreeze is present in the flow being expelled into the pail.
9. Close the fill (primer) hose ball valve for approx. 10 seconds. This allows antifreeze to circulate through the bypass system. Then open the fill (primer) hose ball valve and evacuate the remainder of the water until antifreeze is present.
10. Turn off unit and pump switch.
11. Replace hose on fresh water tank and remove fill (primer) hose.
12. The use of a 12 volt air compressor for connecting to all cleaning tools and high pressure hoses to evacuate water from lines and valves.
13. Remember to reclaim the antifreeze upon start up.

## COMPACT WATER FLOW SYSTEM

The Compact water flow system has been design to be simple and trouble free. The incoming water flows from the fresh water tank through the incoming water filter, then through the chemical injector. As the water passes through the chemical injector, it automatically picks up the predetermined quantity of cleaning solution.

The predetermined quantity of cleaning solution is determined by the chemical flow meter located on the front panel. With this advanced chemical injector, the chemical flow is injected only when there is a demand for water.

Once the water has been injected with the correct amount of chemical it then passes through the high pressure pump, where it is pressurized. The pressure is then control by the BPR (Balanced Pressure Regulator), which is fully adjustable from the front panel.

After the water flow exits the BPR (Balanced Pressure Regulator), it then passes through the dual reverse flow heat exchanger where the water is heated to the preset temperature, which is determined by the adjustable temperature control knob on the front panel.

The water then exits the heat exchangers and continues through the plumbing system to the high pressure quick connects located on the front panel.

**NOTE:** The water flow plumbing system may need to be flushed with vinegar periodically to prevent abnormal chemical or hard water build-up. This can be done by removing the clear hose from the chemical jug and inserting it into a 1 liter (quart) container of vinegar. Then open the chemical flow meter to the setting of 10. With the unit running spray the wand until the 1 litre (quart) of vinegar is empty. Then repeat the process with 1 litre (quart) of water to flush the vinegar out of the lines. If you are in an area with extreme hard water it is suggested to use Coil Cleaner and flush entire water system on a regular basis. For information on how to use Coil Cleaner, contact your nearest Cleanco distributor.

## HIGH PRESSURE PUMP

The Compact 45 & 47 are equipped with a state of the art Cat plunger pump. Cat pumps are built to last, with three ceramic plungers, stainless steel valves and oil-cooled cam-shaft system.

With the Cat pump you have the ability of performing carpet cleaning and power washing, with pressure output ranging from 30 psi to 1200 psi. If 1200 psi is exceeded this can cause damage to the packings and retaining seals in the pump.

Your Cleanco Distributor will preset your Compact unit's pump at a pressure rating between 300 psi and 500 psi during installation. Cleanco has found this pressure range to be the optimal setting for carpet cleaning. When cleaning upholstery a simple adjustment of the BPR (Balanced Pressure Regulator) on the front panel will lower your pressure to 200 psi, which is recommended for upholstery cleaning.

When power washing you must remember that your Cleanco Compact is set up for carpet cleaning. Even though your Triplex pump has maximum rating of 2500 psi, this pump is set up for carpet cleaning will give you maximum 1200 psi for power washing. With 1200 psi and the high heat from the Cleanco heat exchangers it makes power washing simple.

## VACUUM SYSTEM

The vacuum system of the Compact is a Roots Whispair Universal DSL 45 or 47 positive displacement rotary lobe blower. This high performance blower provides incredible air flow and water lift making sure carpets are left as dry as possible. The blower is factory set for maximum efficiency and longevity. The performance and life of the blower greatly depends on the care and proper maintenance it receives.

Due to the close tolerances of the internal lobes and the housing of the blower, solid objects entering the inlet of the blower can damage the interior.

To prevent this, Cleanco installs stainless steel filter screens on the vacuum inlet inside the vacuum recovery tank. This stainless steel filters should be removed daily and cleaned. When reinstalling the filter only thread filter on until finger tight. The lint basket should be removed and cleaned after every job. If lint basket is not clean, it will affect the performance of your machine.

For further information on the Roots Vacuum Blower refer to the enclosed Roots Universal Blower Manual.

## ELECTRICAL SYSTEM

The Cleanco Compact electrical system has been specifically designed with simplicity in mind. There is one complete wiring harness that connects all operations of the unit. This harness is complete with specially designed plug ends, which enable service centers easy front panel removal if necessary. An inline fuse located near the van battery protects the system. All wiring is coated to protect against corrosion from moisture or water spillage.

**NOTE:** Whenever working on wiring system power side of van battery should be disconnected for safety.

## COMPACT 45 & 47 HEAT EXCHANGERS

The Cleanco Compact "MAXI HEAT" heat exchangers are custom built by Cleanco to meet our exacting standards for performance. The heat transfer is quick and efficient, with no potentially damaging heat swings or peaks. The Cleanco Compact heat exchanger is designed with a burst rating pressure of 9000 psi, and operating pressures up to 3000 psi. The unique dual reverse flow exchanger system gets the most heat from the cooling system of your van, using a reverse flow design to maximize heat transfer delivering the highest heat to flow ratio in the industry. The exchangers require little maintenance other than an occasional coil flush to remove hard water residues and scale.

## COMPACT 45 & 47 PTO SYSTEM

The power take off shaft (PTO), is a precision engineered and balanced shaft that transfers power from

the van's engine to the Compact unit, which drives the vacuum and high pressure pump. An outer casing with three bearings protects the shaft. These bearings are designed to withstand extremes of heat and friction without breaking down. The PTO shaft has two grease jerk fittings one at the front of the PTO shaft and one at the rear of the PTO shaft. These two bearings require greasing every 250 hours of operation. The recommended grease to be used to grease the bearings is SKF LGMT 3/0.4 bearing grease. The PTO shaft is activated by a single switch located on the front instrument panel. The single switch engages an electric clutch at the front of the shaft in the engine compartment. The shaft is firmly mounted in the engine compartment by the front PTO mounting bracket and at the rear of the shaft by the rear PTO mounting bracket which is mounted to the base plate of the unit.

## COMPACT FRONT INSTRUMENT PANEL

The instrument panel of the Compact puts everything at your fingertips. Complete with vacuum gauge, hour meter, pressure gauge, water temperature gauge and tachometer to monitor all internal workings of the Compact. All electrical is controlled by rocker switches, unit power, fast idle, high pressure pump clutch, interior lights, C.A.D. (Cleanco Auto Drain) and the accessories switch. The BPR (Balanced Pressure Regulator) and Chemical Flow-Meter are both located at the center of the front panel for easy access. To the right side of the panel is the blower lube port and the oil level sight tubes. At the lower left side of the panel are the two high pressure quick disconnects and the C.A.D. (Cleanco Auto Drain). The unique design feature of the Compact front panel, allows complete removal in approximately 90 seconds giving you complete access to the major components.

## COMPACT RECOVERY TANK

The recovery tank of the Cleanco Compact incorporates many unique features to protect your equipment, and save you time. The tank is made from 3/16<sup>ths</sup> powdered coated marine aluminum and contains several baffles to insure strength and durability. The recovery tank holds 100 U.S. gallons (optional 120 gallons) of soiled water solution, giving you longer cleaning intervals between dumping. The safety and convenience features built into the recovery tank include a high water shut-off switch, a built-in lint basket, sloped tank bottom, stainless steel blower protection filters, and an inline vacuum breaker. The high water shut-off is located at the highest point in the recovery tank, giving you full usage of the tanks capacity. The high water shut-off cuts the power to the unit when the tank is full, protecting the vacuum blower from damage. The lint basket prolongs the life of the air filtration system, and makes draining soiled water easier with less clogging and debris. The stainless steel blower protection filters guard against any small debris entering

into the blower chamber which could damage the blower itself. The inline vacuum breaker adds years to the vacuum blower's life by reducing stress caused by plugged filters and limited air intake. The recovery tank also has two access lids for easy access to the lint basket and the stainless steel blower protection filters. These filters require regular cleaning on a daily basis as a minimum. To finish off the recovery tank Cleanco added an integrated storage shelf, giving the operator added space for specialty tools that may be required at the cleaning site.

## MAINTENANCE

To avoid costly repairs and downtime, it is imperative to develop and practice good maintenance procedures. These procedures must be performed on a daily, weekly, monthly, quarterly and bi annual schedule.

As part of your Cleanco package you receive a **Cleanco Maintenance Booklet**. This booklet provides you with a convenient format for recording the required maintenance of your Cleanco unit and van. You are required to perform all maintenance items in the Maintenance Schedule and record that you have done so in this booklet as part of your Cleanco Warranty. It is your responsibility to keep a copy of all repair orders and receipts that relate to your Cleanco unit and Van. These records of services and purchases will be required to substantiate proper maintenance to your Cleanco unit and Van for any warranty claim.

### DAILY

- Check van engine oil.
- Check van engine coolant level.
- Check high-pressure pump oil level.
- Check vacuum blower oil level.
- Clean vacuum tank lint basket. **(Should be cleaned after every job)**
- Clean the stainless steel blower protection filters.
- Lubricate blower with Cleanco's blower lubricant.
- Winterize system if necessary.

### WEEKLY

- Check engine air cleaner filter. (clean as necessary)
- Check Front drive belts. (adjust if necessary)
- Check blower belts. (adjust if necessary)
- Check high-pressure pump belt. (adjust if necessary)
- Clean in-coming water filter.
- Flush chemical system with 50/50 mixture of vinegar and water.
- Inspect unit for loose wires, oil leaks, and water leaks.
- Check engine RPM with unit running at fast idle. (setting 1450 RPM under load )

- Blower Speed. (actual reading)
- Vacuum Gauge. (actual reading)
- Temperature Gauge. (actual reading)
- Hour Meter. (actual reading)
- Clean wand and inspect for clogged jets.
- Clean recovery tank thoroughly with high pressure water.

### MONTHLY

- Change van engine oil.
- Check van transmission oil level.
- Check van coolant level.
- Check engine air cleaner filter. (clean as necessary)

### QUARTERLY SERVICE

- Change oil in high-pressure pump.
- Change oil in vacuum blower.
- Flush entire water flow system. (coil flush if necessary)
- Check that all nuts and bolts are tight.
- Check all hose clamps, tighten if necessary.
- Grease front and rear PTO shaft bearings with SKF LGMT 3/0.4 bearing grease.

### BI - ANNUAL MAINTENANCE

Change the coolant and flush the coolant system completely.

## AS REQUIRED / COIL FLUSH

If your area has hard water you may see evidence of hard water deposits form in the water system, or on the quick connects. If scale is present, the water system should be flushed with Coil Cleaner. This procedure may have to be increased to a monthly interval if heavy built-up is present. For information on flushing coils contact your nearest Cleanco distributor.

Over all machine maintenance and appearance is very important. It represents your company's professional appearance and is how you make your living. A clean well maintained machine will give you years of reliable performance. Maintenance, troubleshooting, and repair is much easier on a clean well maintained unit. Regular cleaning and maintenance will give you the opportunity to spot any potential problems normally before they occur.

It is important that you follow and record the maintenance on your Cleanco unit and van according to the Cleanco Maintenance Booklet to insure complete warranty coverage.

## **TROUBLESHOOTING GUIDELINES**

### **Loss of Vacuum:**

- Ensure recovery tank drain valve is closed.
- Ensure recovery tank access lids are on properly.
- Check recovery tank lid gaskets are in good condition.
- Check stainless steel blower protection filter, clean if required.
- Check vacuum tank lint basket, clean if required.
- Check for blockage in cleaning tool or vacuum hose.
- Check vacuum hoses for kinks, and good connections.
- Check vacuum hose between blower and recovery tank.
- Check belt tension between blower and pto shaft.
- Check belt tension at front of pto shaft.

### **Loss of Water Pressure**

- Check fresh water tank for adequate water level, if connected to direct feed water tap ensure tap is in the on position.
- Inlet water feed line collapsed or clogged.
- Inline water filter strainer clogged or damaged.
- Air leak on the inlet water line from water source to high pressure pump.
- Check BPR (Balanced Pressure Regulator) for blockage and proper setting.
- Check for lose pump belt.
- Check chemical jug, ensure there is enough chemical.

### **Water Pulsation**

- Foreign material in pump valves.
- Air leak on the inlet water supply line.
- Air leak on chemical metering line.
- Inadequate water supply.
- Foreign material in BPR (Balanced Pressure Regulator).

### **No Hot Water**

- Check temperature control valve setting, ensure its turned to hot.
- Check engine coolant level, top up if required.
- Flush heat exchangers with approved coil cleaner.
- Possible air lock in water flow system, make sure coolant level is at proper level then open pet-cock valves located on the heat exchangers and bleed air from heat exchangers, then close pet-cock valves.
- If problems persist contact your nearest Cleanco service center.

### **No Chemical Feed**

- Check chemical jug level and top up if necessary.
- Check chemical feed hose for leaks or cracks.
- Check chemical feed check valve located on the end of the chemical feed hose in the chemical jug for blockages.
- Check chemical flow-meter for blockages.
- Check chemical feed hose from front panel to chemical injector tee for leaks or cracks.

### **No Unit Power**

- Check in-line fuse located at the vehicle battery or fuse box accessory post.
- Check to ensure recovery tank is not full.
- Check recovery tank shut-off switch for proper operation.
- Check front pto clutch power and grounding wires.
- Check unit power rocker switch for lose wires.
- Check Hi-Temp shut-off connections on heat exchanger and at wiring harness.

### **Unit Will Not Idle Up**

- Ensure vehicle is in park.
- Ensure Park Brake is engaged.
- Check which lights are flashing on E.T.M., all should be on steady. IF no lights are on check fuse #30 on GM's.
- If unsuccessful see your local authorized Cleanco service center.

### **Unit Shuts Down Unexpectedly**

- Check recovery tanks level and drain if required.
- Check in-line fuse located at the vehicle battery.
- Check recovery tank shut-off switch to ensure proper function.
- Check Hi-Temp shut-down on heat exchangers.
- Check pto clutch power and grounding wires.
- Check Hi-Temp shut off on heat exchangers.

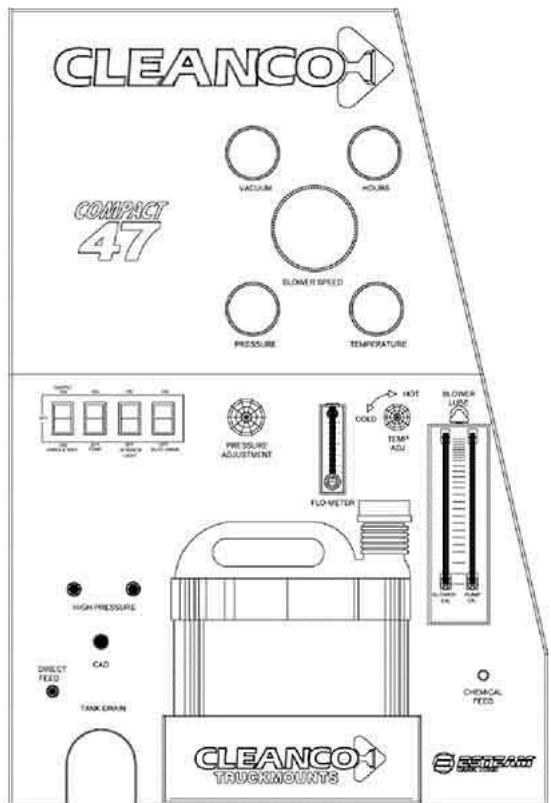
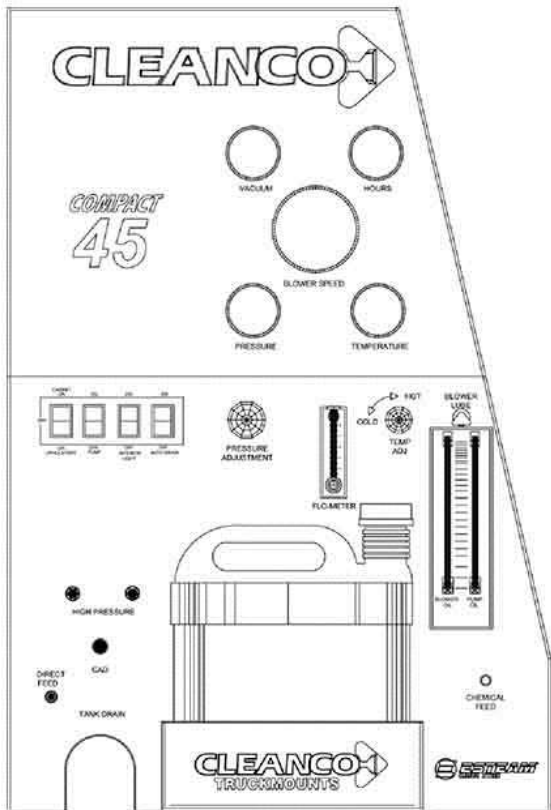

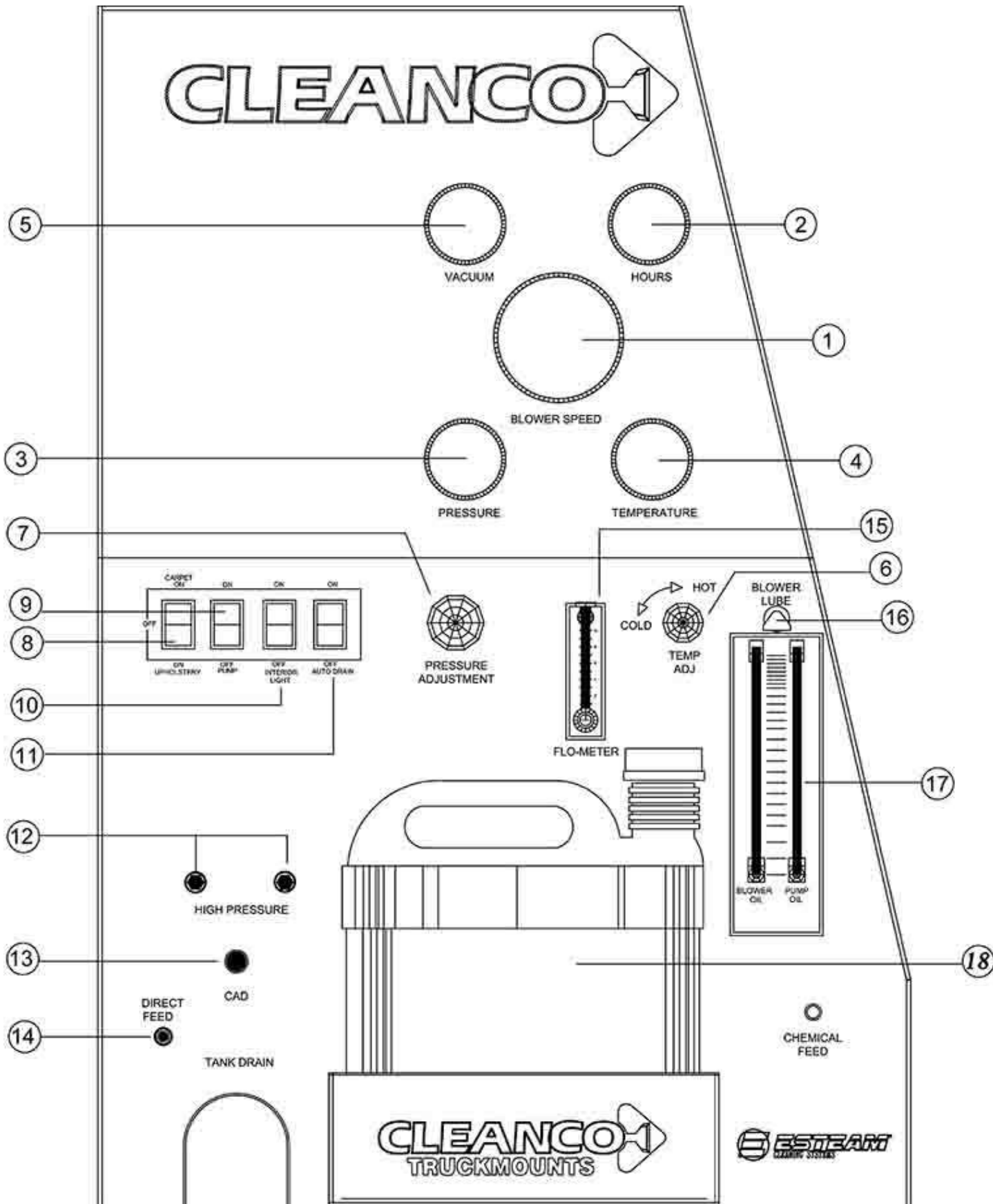

1. **Tachometer**  
The Blower Speed shows the rpm of the Blower.
2. **Hourmeter**  
The hour meter records the number of hours the unit has run. This serves as a time recorder for servicing the machine and van.
3. **Solution Pressure Gauge**  
This gauge registers the amount of pressure in the system.
4. **Solution Temperature Gauge**  
This gauge measures the temperature of the cleaning solution as it exits the machine.
5. **Vacuum Gauge**  
This gauge indicates in inches of mercury how much the vacuum system is producing at any given time.
6. **Solution Temperature Control**  
This valve allows the operator to control the solution temperature by adjusting the valve from cold to hot.
7. **Pressure Control Regulator**  
The pressure regulator sets the pressure of the solution system. This spring loaded valve can be adjusted up or down setting the pressure of the unit by turning the knob clockwise. The pressure is increased or reduced by turning the valve counter clockwise. This valve must be maintained in accordance with this manual maintenance table.
8. **Main Power Switch**  
The switch serves to energize the magnetic clutch to turn the P.T.O.
9. **Pump Clutch Switch**  
This switch serves to energize the magnetic clutch to turn the water pump on or off.
10. **Interior Light Switch**  
This switch controls the spot lights located in the cargo area.
11. **Auto Drain Switch**  
This switch controls the (Optional) auxiliary pump to drain the waste collection tank automatically. A float switch located inside the tank automatically turns on and off when the solution level reaches a certain level.
12. **High Pressure Outlets**  
The high pressure solution outlets are the connecting points for the high pressure hoses. These outlets have quick connects that allow hoses to be plugged into the unit.
13. **C.A.D. Port**  
This port is used when the (Optional) Auto Drain is installed on the unit. It will accept standard garden hoses. Waste tank solution should only be dumped according to Local, State, Provincial, and Federal Laws.
14. **Direct Feed**  
This port is used when the (Optional) Water Box is being used instead of an "on board tank".
15. **Flow Meter**  
The flow meter is a gauge to indicate how much liquid detergent is being introduced to the water system. Turning the knob on the flow meter clockwise can increase the quantity.
16. **Blower Lube Port**  
The oil cup allows lubricant spray to reach the lobes of the vacuum pump.
17. **Oil View lines**  
The oil view lines indicate levels of oil in both the vacuum pump and water pump. They are "indicators only". Vehicle must be on a level surface.
18. **Detergent Bottle**  
The detergent bottle holds the concentrated detergent used in the operation of cleaning.

## **Water Pumping and Heat Transfer System:**

Cold water enters the panel through the water inlet. When the water tank is full the valve will automatically shut off.

Water then flows from the water tank, through a strainer, into the water pump where chemical is introduced at this point. Then it is pumped to the pressure regulator that provides and maintains the desired pressure setting.

A certain amount of water is by-passed from the pressure regulator due to over pumping capacity of the water pump. Water that is not called for in the cleaning process is channeled to the by-pass coil in the recovery tank then flows to the inlet side of the pump to be circulated again.

The heating stage occurs when the water leaving the pressure regulator and directed to the first of two heat exchangers. Heat from the vehicle engine coolant is exchanged to the cleaning solution spiraled copper tubing. This allows the engine coolant to travel in a counter rotating direction to the cleaning water during the exchange process creating a very efficient transfer of heat out of the engine and into the cleaning solution.

The hot solution then exits the second heat exchanger where it enters the outlet manifold. The manifold serves as a sensing point and connection for the high-pressure hoses.

Finally, the cleaning solution then passes through pressure hoses and is distributed by the cleaning tool to a surface that is being cleaned, completing the water pumping and heating cycle of the cleaning unit.

## **Optional P.T.I.**

With the Optional Post Thermal Increase, the cleaning solution goes to a second stage of plumbing and heating which takes place in the heater core located just after the vacuum pump. This is the hottest point of exhaust air coming from the vacuum pump. The hot exhaust air is forced through the post heat core, creating the second stage of heat transfer to the cleaning solution.

## **Required Maintenance of P.T.I.**

Annual inspection of the fins inside the P.T.I. is a requirement do to the potential folding over of the fins or build up of debris, lint, dirt etc. This will cause excessive stress on the drive line including

the blower, PTO shaft and PTO clutch. The blower must be removed to see the possible results of the wear and tear on the fins. Cleanco would recommend this procedure be done by a Qualified Service Center.

## **Heat Max P.T.I Operating Instructions:**

### **Overview**

The "Heat Max P.T.I." is designed to transfer the exhaust heat generated by the vacuum blower, to the cleaning solution as the final heating stage. To fully understand the heat transfer system of the Cleanco Compact the following steps occur.

Before the P.T.I. will efficiently transfer heat to the cleaning solution, the blower must be brought up to temperature. This is accomplished when the vehicle coolant system is first brought up to operating temperature either through idling or driving to the job site. Then the unit must be turned on to high idle with the vacuum port of the recovery tank closed off with the plug on the inlet barb. The operating temperature of the P.T.I. will be available in about ten minutes of running unit. The P.T.I. will take much longer to reach operating temperature if this procedure is not done and in fact will cool the water until the blower can reach the desired transfer heat rate.

### **Step 1**

The water flows from the fresh water tank through a strainer, into the water pump where it is pumped to the pressure regulator providing constant desired pressure.

### **Step 2**

The next stage of water flow is to the heat exchangers (Dual or Quad), when water is called for in the cleaning process, it flows to the heat exchangers under pressure. Heat from the engine coolant is exchanged to the cleaning solution through a series of spiraled copper tubing. This allows the engine coolant to travel in a "reverse flow" direction to the cleaning solution creating a very efficient transfer of heat out of the engine and into the cleaning solution.

### **Step 3**

The last stage of the heat exchange takes place in the "Heat Max P.T.I." located under the baseplate. This is the hottest point of the exhaust from the vacuum blower which is forced through the "Heat Max P.T.I.". The cleaning solution travels from the



heat exchangers to the "Heat Max P.T.I" where it is channeled through a series of stainless steel tubing. The exhaust heat from the vacuum blower is transferred to the stainless steel tubing, boosting the temperature of the cleaning solution.

#### Step 4

The hot cleaning solution passes to the outlet manifold, this manifold serves as a temperature sensing point and connecting point for the high pressure solution hoses. The cleaning solution then passes through high pressure hoses and is distributed by the cleaning tool to the surface that is being cleaned.

### Operating System

#### Step 1

Arriving at the job site, same routine applies: pre-inspection, precondition, run hoses and tools required into the site.

#### Step 2

Turn unit power on, then turn on pump, set chemical meter and enter the site to begin cleaning.

#### Step 3

Clean as normal using the recommended orifice sizes listed below for the wand and stair tool.

#### Step 4

It will take approximately 15 minutes of normal cleaning for the vacuum blower to generate desired temperatures of 230°F - 240°F. As the carpet wand vacuums the carpet it generates a "load" on the vacuum blower, this in turn then reaches and maintains optimum temperature for maximizing the "HEAT MAX P.T.I." heat transfer.



**DO NOT FREEZE! UNIT IS IRREPARABLE IF FROZEN.**

**HOTTER WATER TEMPERATURES WILL CAUSE PREMATURE DETERIORATION OF HIGH PRESSURE HOSE, VALVES, ORINGS, ETC.**

#### JET SIZING

For maximum heat and overall unit performance, the recommended floor tool jet sizing not to exceed a total of ".045". Using larger jet sizes on your cleaning unit may reduce cleaning temperatures.

**Example:** Dual-jet wand uses two 110015 jets (110° spray angle with 015 orifice).  
 $015 \times 2 = .03$   
Stair tool jet size: 11003

# WATER PUMPING AND HEAT TRANSFER SYSTEM

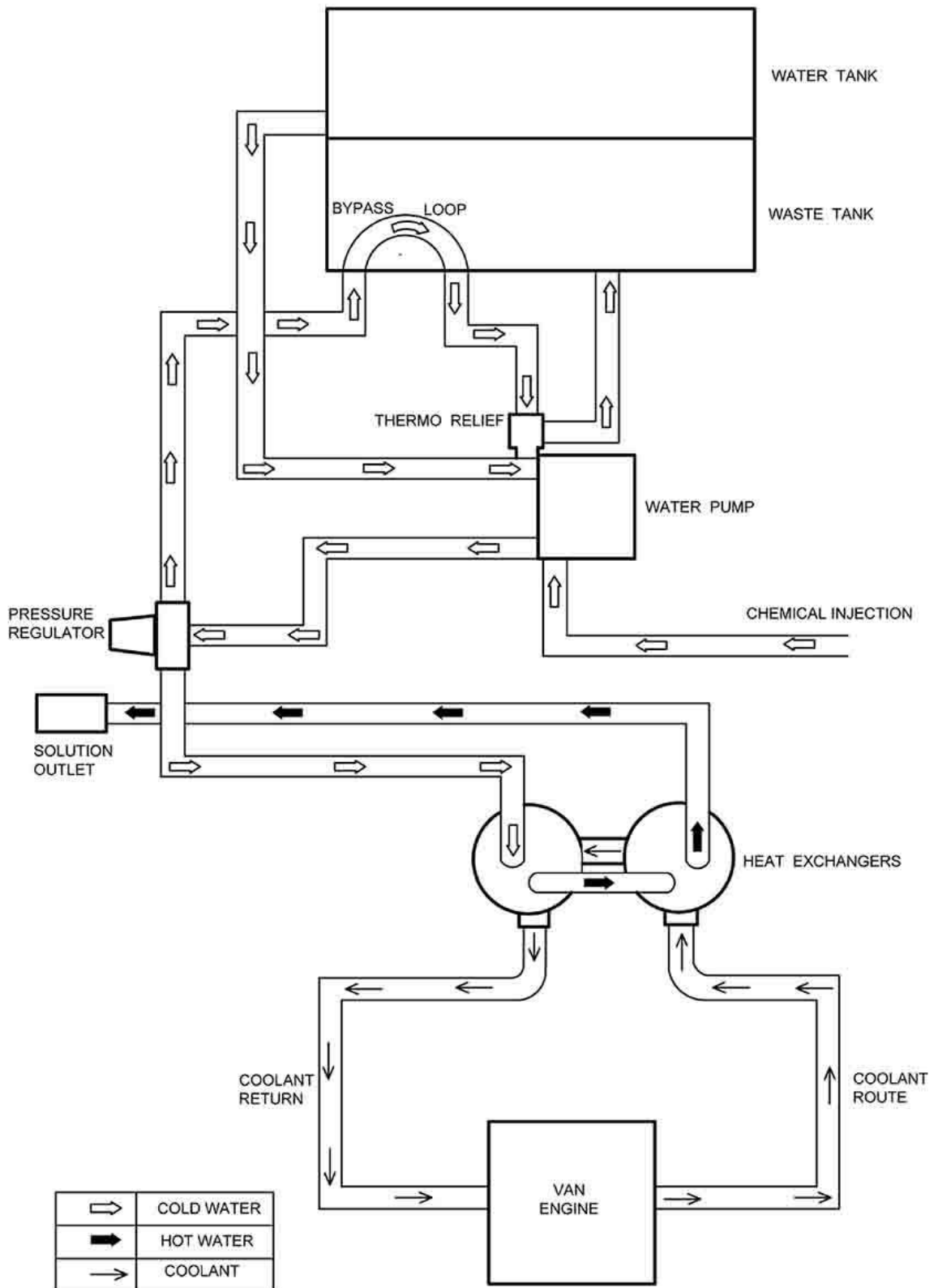

## WATER PUMPING AND HEAT TRANSFER SYSTEM (DUAL HEAT EXCHANGER) WITH P.T.I. OPTION

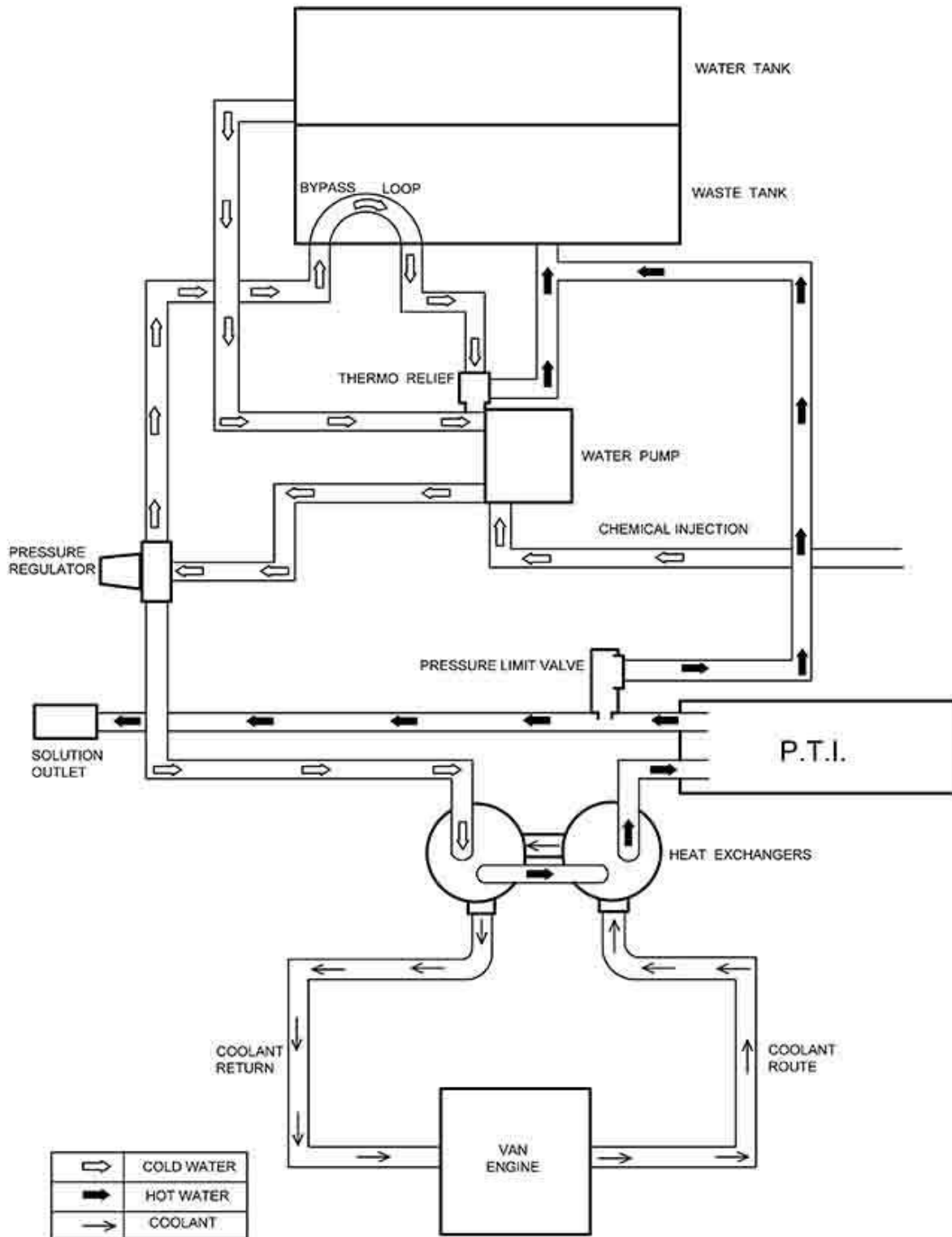

## **CHEMICAL INJECTION SYSTEM**

The chemical injection system utilizes the natural inlet draw of the high-pressure pump to move the chemical into the main pressure stream.

The chemical is picked up from the container and fed through the flow meter at a desired

amount of chemical which is adjusted through the metering valve.

The chemical and water are mixed in the high-pressure pump and then forced through the heat exchangers and outlet manifold where then it is distributed to high-pressure hoses out to the cleaning tool

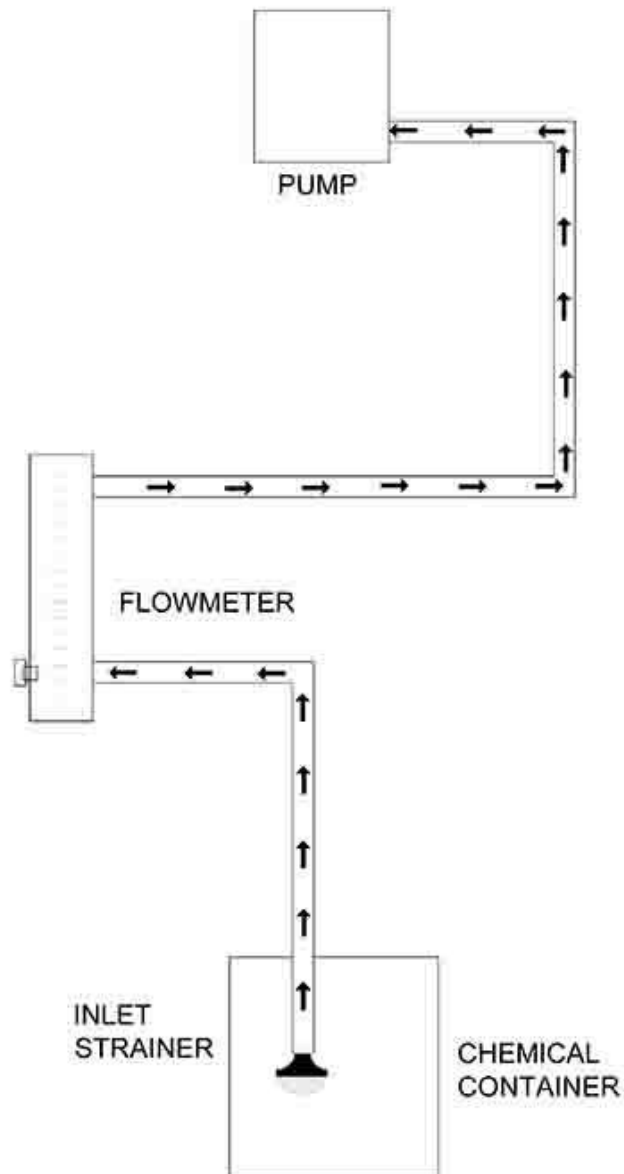

## VACUUM SYSTEM

The PTO turning an air pump generates vacuum. The air is channeled in one side of the vacuum pump, compressed and discharged on the opposite side, creating airflow.

The movement of air is used to do the work necessary for the extraction process. A vacuum nozzle applied to the carpet surface removes moisture, dirt and spent chemicals. These elements are conveyed back to the waste tank using a series of changes in direction and

velocity. The air is then filtered and rushes into the vacuum pump.

The vacuum pump compresses and heats the incoming air. The hot discharged air is forced down stream into a silencer for noise abatement. Finally the hot air is exhausted outside.

### **NOTE:**

WITH THE OPTIONAL P.T.I., THE HOT DISCHARGED AIR IS FORCED THRU THE P.T.I. BEFORE BEING EXHAUSTED OUTSIDE.

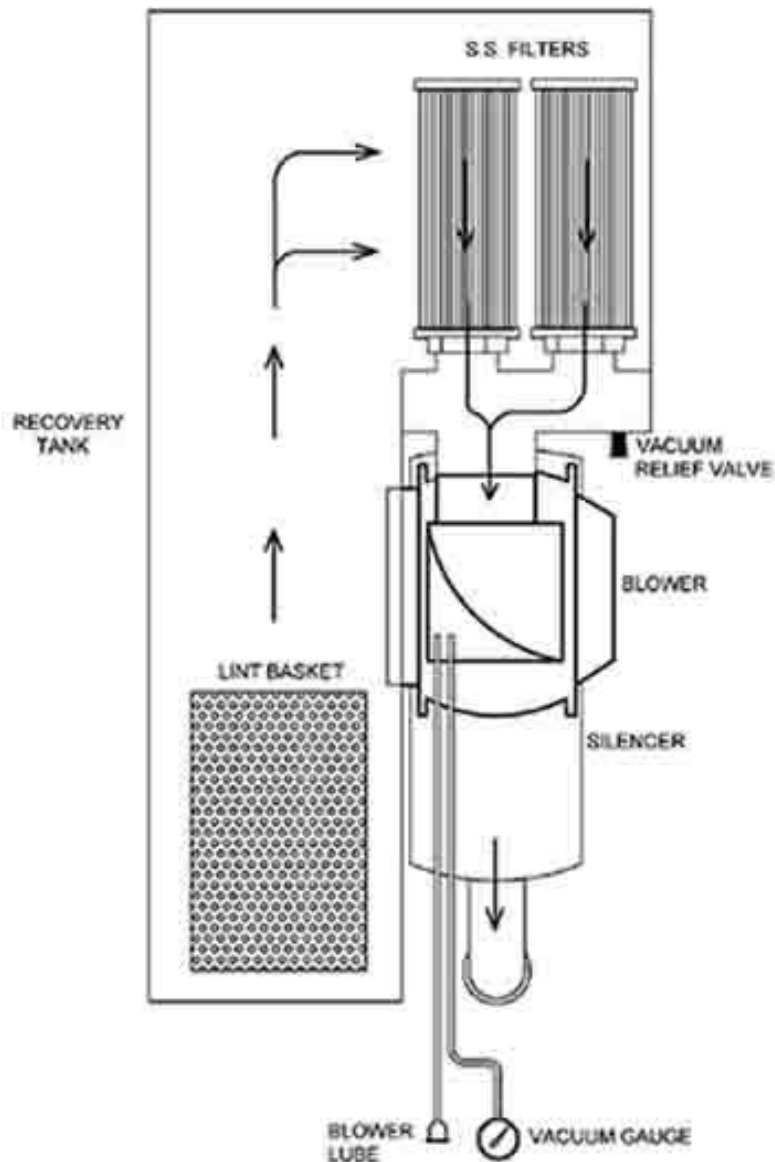

## **VACUUM PUMP**

Refer to the Vacuum Pump Operation and Service Manual for specific instructions.

**Lubrication:** We recommend that you use Roots Synthetic Blower Lubricant in the vacuum pump for all operation temperatures. This lubricant is formulated especially for positive displacement blower service to provide maximum blower protection at any temperature. One filling of Roots Synthetic oil will last many times longer than a premium mineral oil.

**NOTE: Roots Synthetic oil is the oil which ESTEAM puts in the vacuum pump at the factory. Topping off or adding petroleum oil to synthetic oil is NOT recommended.**

1. Check the oil level **daily** to assure the proper level. **PROPER LEVEL** cannot be overemphasized. Too little oil will ruin bearings and gears. Too much oil will cause overheating. Use the illustration as a guide when adding oil.
2. To prevent rust from building up inside the vacuum pump (if moisture exists) we have provided a lubrication cup on the front of the unit.

First run the unit at least **1 minute** to remove any moisture from the vacuum pump. Next, fill the lubrication cup with WD-40, or a similar lubricant, for **5 seconds** while the unit is running and the vacuum inlets are sealed. Do this at the end of **each working day**.

3. Drain, flush and replace oil **every 200 hours or yearly, whichever comes first**. Change oil more frequently if inspection so indicates. With Roots Synthetic lubricant, perform the oil change maintenance **every 500 hours or once per year, whichever comes first**.

4. Vacuum pump lubrication is vital to performance of our pump. Failure to follow the maintenance schedule in the "Maintenance Schedule" can lead to permanent damage to your blower.

## **WATER PUMP**

1. Check the crankcase oil level **daily** to assure the proper level. Use the illustration as a guide when checking the oil level. If the level has dropped, check for the source of leakage and repair.
2. Change the crankcase oil with Cat Pump Crankcase Oil, after the **first 50 hours** of operation. Drain and refill the crankcase oil with Cat Pump Crankcase Oil **every 500 hours** thereafter.
3. Other Cat approved oil equivalents are: Mobil DTE 16, Amoco Rykow 68, and Shell Tellus T68.

## **VACUUM INLET FILTERS (IN WASTE TANK)**

1. The vacuum filters in the waste tank should be removed and cleaned **daily**. If this is done, the filters will last for a long period of time.

## **VACUUM RELIEF VALVE**

While the unit is running at full RPM, block the air flow at the vacuum inlet connection and read the vacuum gauge. If adjustment is required, shut the unit down and adjust the vacuum relief valve locking nut tension. Start your unit and read the vacuum gauge. Repeat this process until the relief valve opens at 14" Hg on a Compact 45 and 14"Hg on a Compact 47.

## VACUUM PUMP DRIVE BELTS

To tighten the vacuum pump belts:

1. Loosen the centre nut (left hand) that holds the tensioner to the tensioner bracket.
2. Using a tensioner wrench rotate the rear of the tensioner to 75° for the Compact 45 or 47. For more information contact your local authorized Cleanco service center.
3. Roll the belts back onto the blower pulley. The centre line on the inside of the tensioner should be positioned between the second and third line on the outside of the tensioner.

**NOTE: When adjusting belt tension, make certain that the PTO shaft and vacuum pump shaft remain parallel, and the belt tension is equal throughout the belt width.**

4. After adjusting, check belt alignment with straight-edge.

**Make certain that when you re-torque these screws, that you use a clockwise pattern and continue until proper torque is achieved.**

TORQUE VALUES		
COMPONENT	INCH/LBS	FOOT/LBS
Rear PTO Hub	300	15
Vacuum Pump Hub	300	15

5. Check for pulley groove wear, clean belts and pulley grooves, check for worn belts, proper belt tension, and pulley alignment after the **first 25 hours** and then again at **100 hours**. Check for belt ride in the groove.

## PRESSURE REGULATOR

Lubricate the o-rings and bullet **every 50 hours**. Use o-ring lubricant or synthetic grease.

For the procedure, see the "General Service Adjustments" section in this manual for details.

## VACUUM HOSES

To assure maximum hose life, we recommend that the hoses be washed out with clean water at



the end of each **working day**.

## HIGH PRESSURE HOSES

Inspect your high pressure hoses for wear after the **first 100 hours** of use. Inspect **every 25 hours thereafter**. If hoses show any signs of damage or impending rupture, **replace the hose**.

**DO NOT attempt to repair high pressure hoses! Repairing high pressure hoses may result in severe burns and serious injury!**

***All high pressure hoses must be rated for 3000 PSI at 250 deg F. Thermoplastic hoses do not meet these specifications and should not be used. Severe burns and injury may result if the hoses do not meet these requirements.***

## OPTIONAL WASTE PUMP-OUT

**At the end of each work day**, make certain that you remove any debris or sediment which may be inside the waste pump by pumping fresh water through the pump.

## **ENGINE COOLANT REPLACEMENT**

Annually the coolant in the Vehicle Engine should be replaced. This coolant is an integral part of the heating system and needs to be maintained as any other working part of the system. We recommend that this procedure be accomplished by the following steps.

### **DRAINING COOLANT:**

1. Remove one end of Heater core "Y". Open Heat Exchanger Petcock's.

**NOTE: Be sure that used coolant is collected in a proper container and disposed of in accordance with local laws.**

### **REPLACING COOLANT:**

See your authorized Cleanco service center, as special procedures and tools are required.

## **WATER PUMP DRIVE BELT**

To tighten the water pump belt:

1. Loosen the nuts which hold the water pump mount to base.
2. Adjust the position of the belt tension adjusting bolt until the proper belt tension is achieved. (1/2" deflection in the center of the belt, halfway between the pulleys).
3. While checking the alignment, tighten the nuts which hold the water pump mount to base.

## **WASTE TANK LINT BASKET**

The lint basket located inside the waste tank should be removed and cleaned whenever it is full of debris. This should be done at the end of each job.

## **WASTE TANK FLOAT VALVE**

The float valve in the waste tank shuts the unit down once the waste tank becomes full. Check the float valve for debris at least once a month.

## **INLINE WATER FILTER**

The filter is located on the inlet plumbing assembly of the pump. Clean this filter once a week.



## TROUBLE SHOOTING

<b>PROBLEM</b>	<b>CAUSE</b>	<b>SOLUTION</b>
PTO will not engage	Recovery tank is full.	Drain recovery tank.
	Main power fuse is blown.	Replace fuse.
	Recovery tank switch is stuck or defective.	Examine switch replace if necessary.
	Faulty connection at Hi-Temp shut-down	Check and secure connection at both sensor and harness
	Front or rear belts broken.	Replace belts.
Engine speed will not increase	Recovery tank is full.	Drain recovery tank.
	Park brake not engaged	Engage park brake.
	Fast idle switch is off.	Turn switch on.
	Throttle Module (ETM)	See authorized Cleanco service center
<p>Loss of water pump pressure.</p> <p>With the cleaning tool open, the water pressure gauge reads below the normal operating pressure.</p>	Water supply is turned off or the float valve is stuck or improperly adjusted.	Turn the water supply on or up. Check for kinks in the water supply hose. Examine the float valve and adjust or replace.
	Water pump inlet supply line is plugged or drawing air.	Examine the water inlet filter inside the water box. Remove accumulated debris and replace if required. Check for suction leaks and loose clamps or fittings. Tighten any loose fittings or clamps. Replace any ruptured hose(s).
	Pressure regulator o-rings are dry.	Lubricate o-rings, using o-ring lubricant.
	Pressure regulator has worn o-rings.	Check o-rings. If necessary, replace.
	Pressure regulator is dirty, stuck open, or improperly adjusted.	Clean or repair regulator. Adjust to working pressure. Lubricate o-rings, using o-ring lubricant.
	Low pump volume. (Measure the amount of water being returned to the water box from the pressure regulator. It should fill a gallon container about every 17 seconds).	Examine the check valves, plunger cups, and cylinder head on the water pump. Repair, whenever required (refer to the water pump service manual).
	Defective water pressure gauge.	Replace gauge
	Orifice (spray nozzle) in the cleaning tool is worn, defective, or wrong size.	Replace nozzle or change nozzle size.
	Debris clogging water lines or water inlet disconnect.	Clean or replace as needed.
	Belts loose or broken.	Re-tension or replace as needed.
	Loss of pump prime.	Manually prime water pump.

<b>PROBLEM</b>	<b>CAUSE</b>	<b>SOLUTION</b>
Loss of solution volume at cleaning tool orifice.  Water gauge reads normal.	Plugged orifice and/or screen in the cleaning tool.	Unplug or replace orifice and/or screen
	Inlet strainer is clogged.	Inspect all lines, remove accumulated debris which is blocking proper flow. Replace and defective hoses. Remove, inspect, and clean the strainer screen. De-scale unit and install a water softener, if necessary.
	Defective quick-connect on one or more of the high pressure hoses.	Replace defective quick-connects(s) on high pressure hose(s).
	Cleaning tool valve is malfunctioning.	Repair or replace valve.
	Hose inner lining is constricted.	Remove restriction or replace hose.
	Air leak in chemical supply line, metering valve.	Check for air leaks. Replace faulty parts.
Loss of vacuum  While cleaning, the Vacuum is not up to specification. Engine RPM is Normal.	Vacuum gauge is giving an improper reading.	Examine the tubing between the vacuum relief valve and the vacuum gauge and remove any blockage.
	Vacuum hose(s) is damaged, causing a suction leak.	Inspect hose(s), repair or replace.
	Waste tank gaskets not sealing properly, not positioned properly.	Inspect the gasket. Repair seal or replace. Re-position lid(s).
	Plugged vacuum hose or vacuum plumbing between vacuum inlet and lint basket.	Unplug vacuum hose or lint basket.
	Waste tank filter or lint basket is plugged.	Clean or replace filter. Clean lint basket.
	Loose vacuum pump drive Belts.	Tighten the drive belts.
	Waste tank drain valve is damaged or left open, causing a vacuum leak.	Drain the waste tank. Close drain valve, if open. Remove the dump Valve and, after inspecting, replace the defective components.
	Vacuum relief valve requires adjustment or has a vacuum leak due to damaged Diaphragm.	Re-adjust the vacuum relief valve. If the vacuum does not increase, remove and inspect the relief valve diaphragm. If damaged, replace.
Vacuum pump is worn out.	Replace the vacuum pump.	

<b>PROBLEM</b>	<b>CAUSE</b>	<b>SOLUTION</b>
Excessive Vacuum	Improper throttle adjustment.	Adjust throttle to set desired vacuum pressure.
	Vacuum obstruction.	Inspect hoses for obstructions.
	Vacuum relief valve requires adjustment.	Readjust the vacuum relief valve.
Loss of chemical  With the cleaning tool valve open, no chemical.	The strainer at the inlet end of the chemical inlet line is clogged.	Unclog the strainer. If damaged, replace.
	Suction leak in the inlet line leading into the pump.	Inspect inlet lines and flow meter for air leaks or damage and replace, if required.
	Chemical container is empty.	Refill container, then prime system
	Chemical metering valve is defective.	Replace valve.
	Defective cylinder in the water pump.	Measure the pump volume. If the pump volume is less than normal, refer to "Loss of Pump Volume" in the Troubleshooting section in this manual.
Chemical flow meter indicates flow with the tool valve closed.	External leak in chemical piping.	Tighten fittings. Re-apply thread sealant where required. If any fittings are damaged, replace.
Water pump does not engage.	Defective electrical connection in the console wiring or defective switch.	Examine switch, electrical connections, and wiring. Repair any defective connections. If there is power going to the switch but not going out, replace the defective switch.
	Water pump has not been activated.	Turn solution pump switch to on.
	Defective water pump clutch. NOTE: The clutch may be manually set by inserting two 1/4 x 20 x 1/2 bolts. Line up the holes on the clutch and insert the bolts. To disengage the pump, remove the bolts.	If there is power in the switch, but not power at the clutch, replace the defective wire. If there is power at the clutch, replace the defective switch.
	Loose or broken water pump belts.	Tighten or replace belts.

**CLEANCO COMPACT OVERHEAD VIEW**  
**(DUAL HEAT EXCHANGER)**

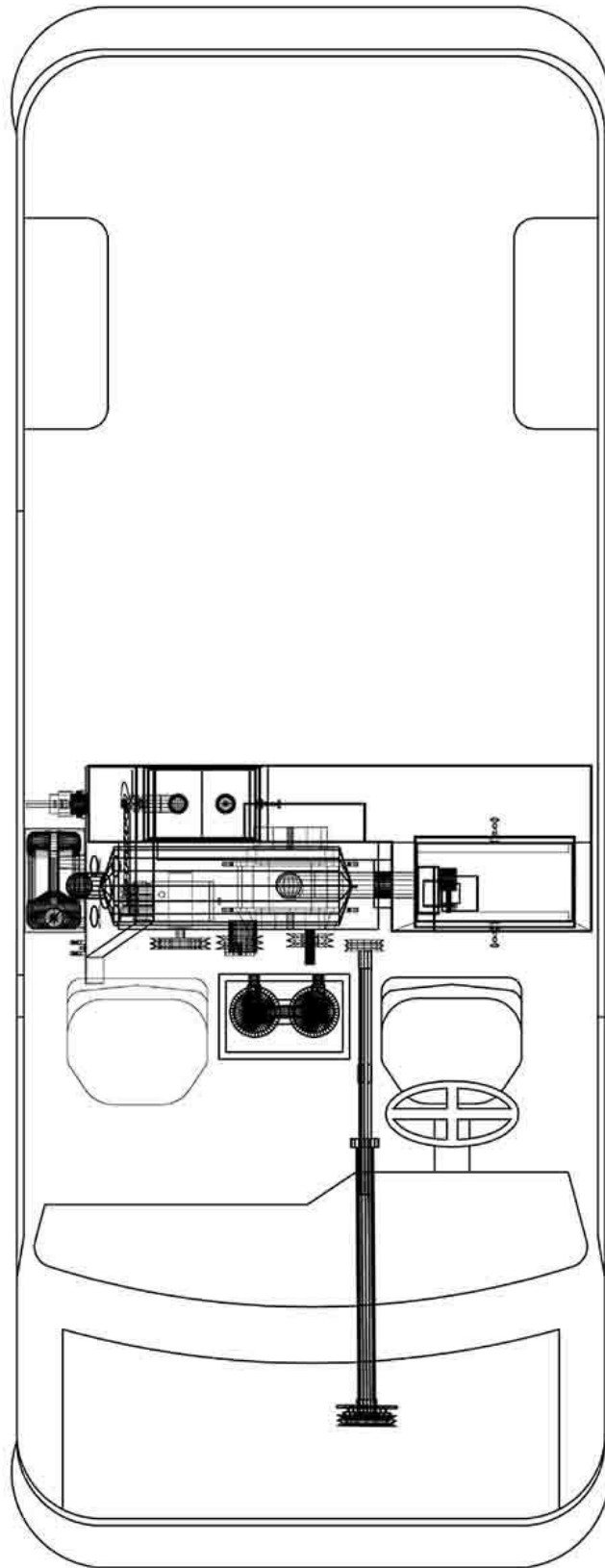

# CLEANCO COMPACT WITH ELECTRIC HOSE REEL OVERHEAD VIEW

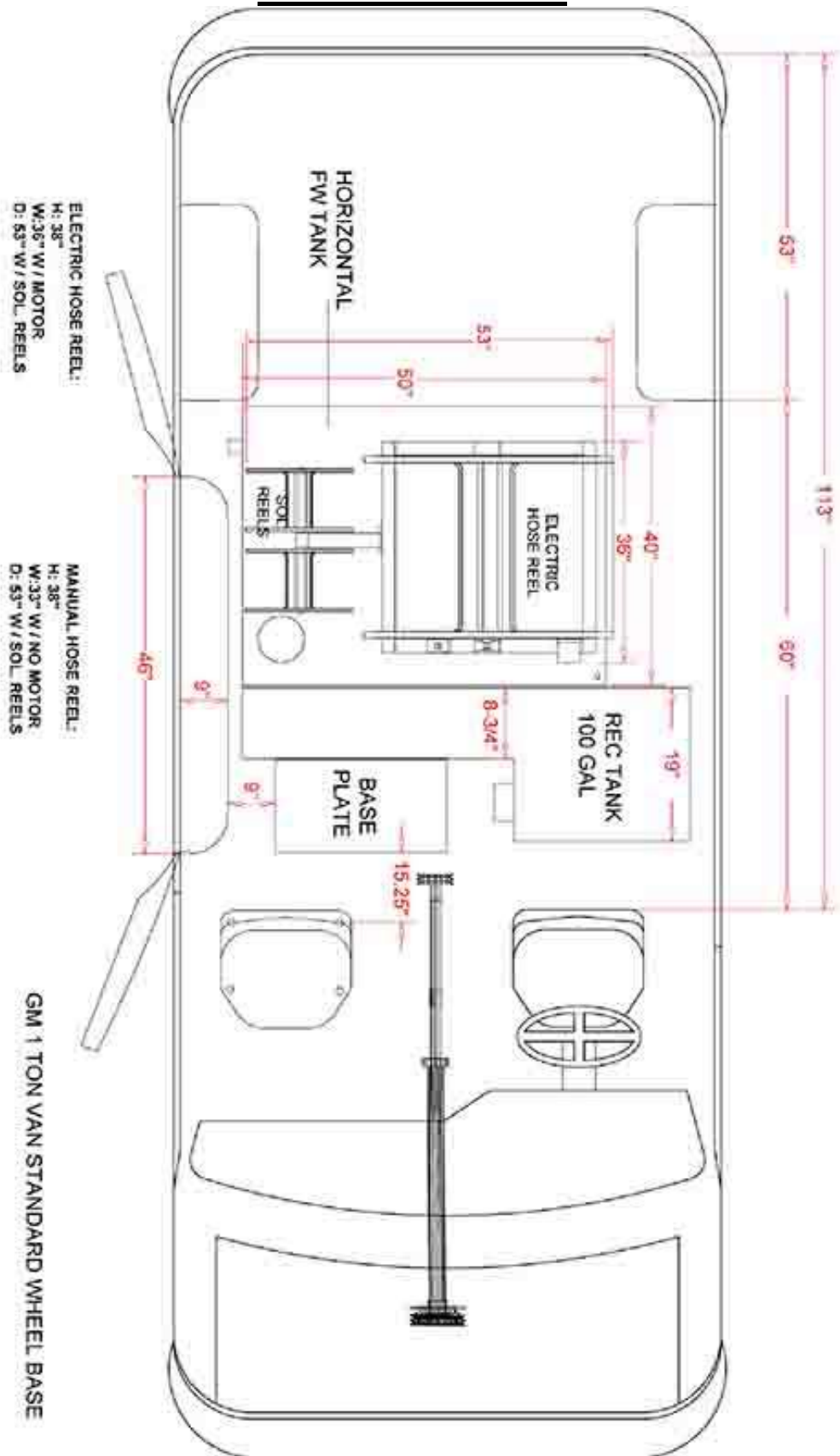

# FRONT PANEL 45 & 47 FRONT VIEW

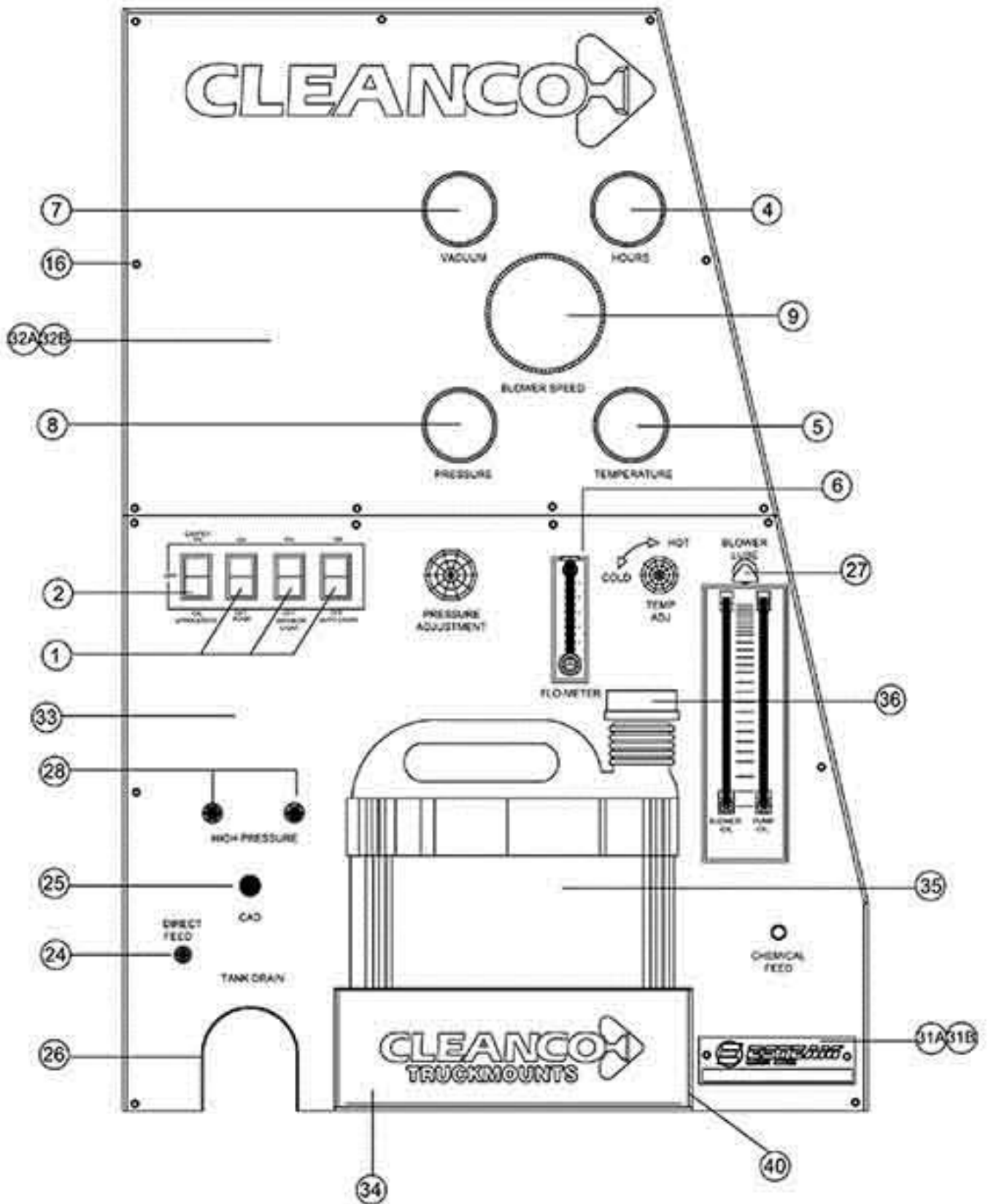

**FRONT PANEL 45 & 47 BACK VIEW**

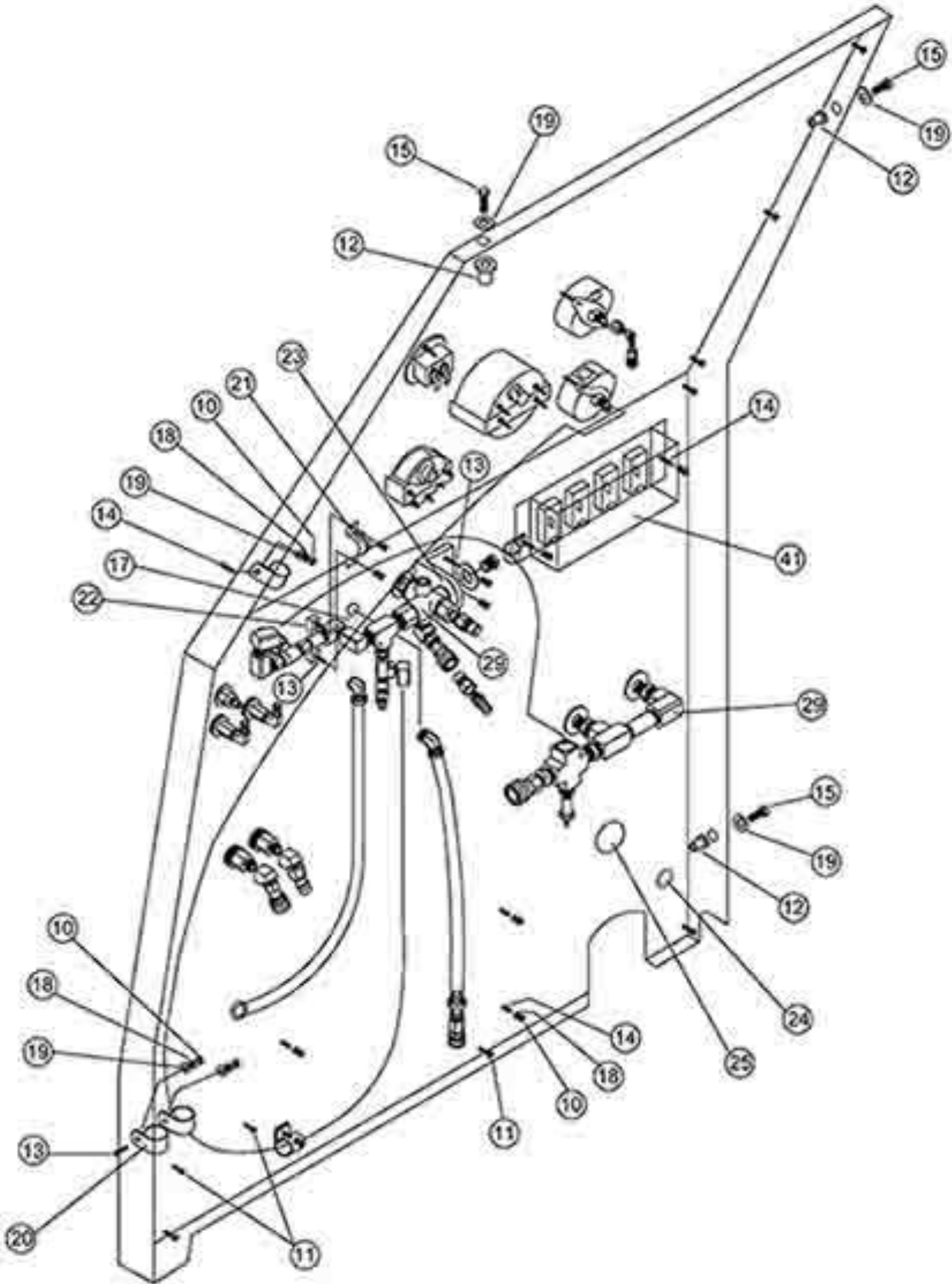

## FRONT PANEL 45 & 47

REF	PART NO.	DESCRIPTION	NOTES:
1	305-085	Switch, Rocker - White	
2	305-090	Rocker Switch 2 Pole White	
3	328-006	Wiring Harness Compact (Rear Section)	Not Shown
4	360-112	Hour Meter, Truck Mount	
5	360-207	Guage , Temp -Electronic	
6	360-125	Chemical Flow Meter, GPH (2-10)	
7	360-131	Guage, Vac Cleanco	
8	360-145	Guage, 2000 PSI Black BMT Cleanco	
9	360-212	Tach/ Blower Speed	
10	400-005	Hex Nut, 1/4" x 20" SS	
11	400-125	Locknut, 8" x 32" Nylon S.S.	
12	400-250	Well Nut, 1/4" X 20" Neopene	
13	405-600	Clinch Stud, 1/4" X 1" S.S.	
14	405-610	Clinch Stud, 1/4" X 3/4" S.S.	
15	435-055	Knob, Thumb	
16	410-105	CS, 8-32 X 1/2" SOC S/S	
17	410-220	MS, 10-32 X 3/8" Pan RB Zinc	
18	415-025	LW, 1/4" SS	
19	415-125	FW, 1/4" SS	
20	425-140	Clamp, Tube 3/4"	
21	460-010	Strap, 1/2"	
22	465-670	BRKT, Clamp Panel	
23	465-675	BRKT, Angle	
24	498-050	Plug, 5/8" Nylon	
25	498-070	Plug 1" Nylon	
26	499-005	Trim, 1/2" Black	
27	551-075	Vac Lube Port	
28	580-010	Q.C 1/4 Female (Close)	
29	620-200	Plumbing ASSM (Complete)	Not Shown
30	620-205	Wiring Harness (Complete)	Not Shown
31A	703-345	Decal, 45 S/N Plate	
31B	703-347	Decal, 47 S/N Plate	
32A	703-501A	Decal, 45 Panel	
32B	703-502A	Decal, 47 Panel	
33	703-504A	Decal, Compact Bottom Panel	
34	703-507	Decal, Chemical Jug BRKT	
35	759-005	Chemical Jug 10L	
36	759-015	Lid, Jug 10L & 20L	
37	845-281	Panel Frame, Compact	Not Shown
38	845-283	Panel, overlay, Top-Compact	Not Shown
39	845-284	Panel, overlay, Bottom-Compact	Not Shown
40	845-295	BRKT, Chemical Jug-Compact	
41	845-331	Cover, Panel Switches	



# FRONT PANEL PLUMBING (P. 1)

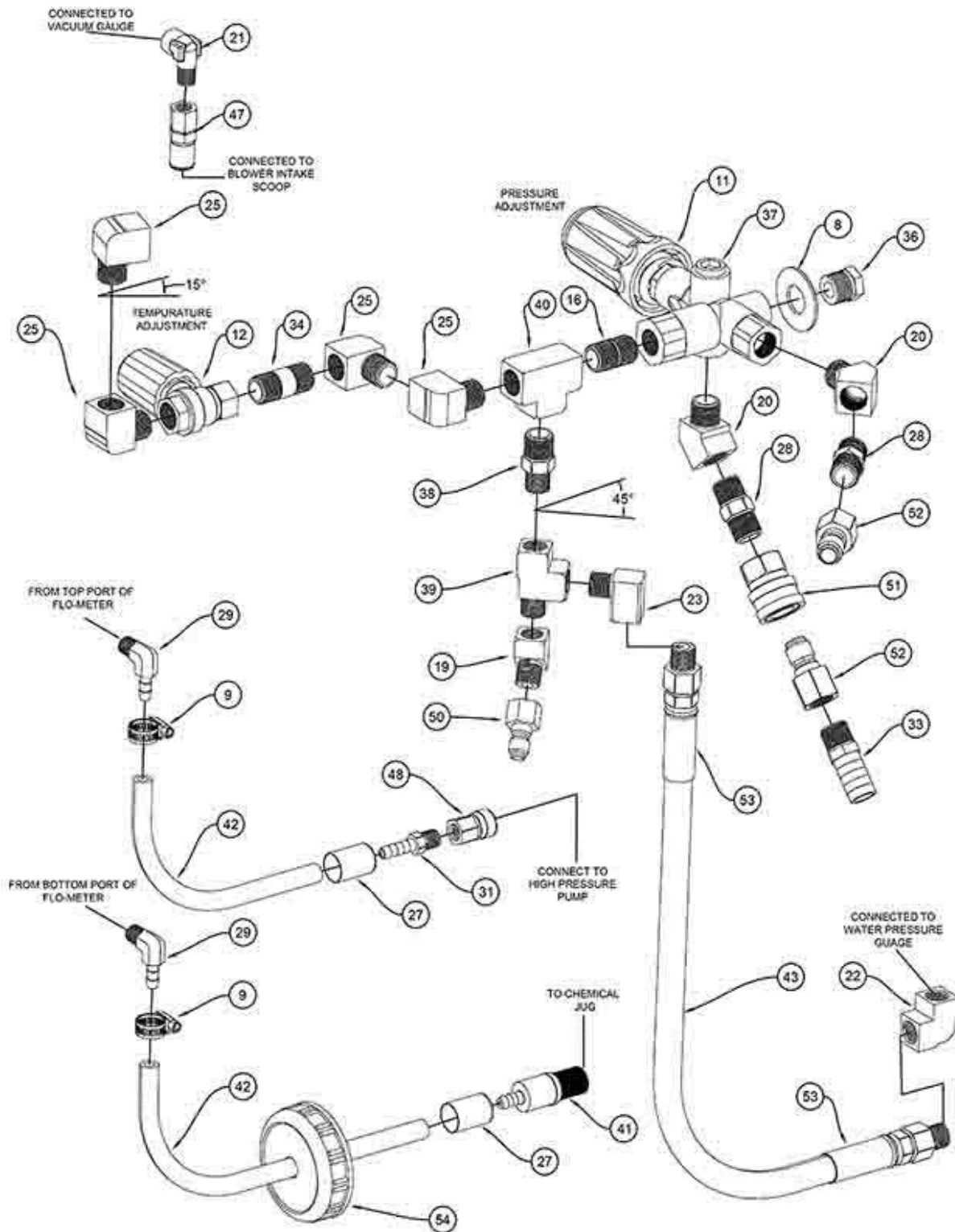

## FRONT PANEL PLUMBING (P. 2)

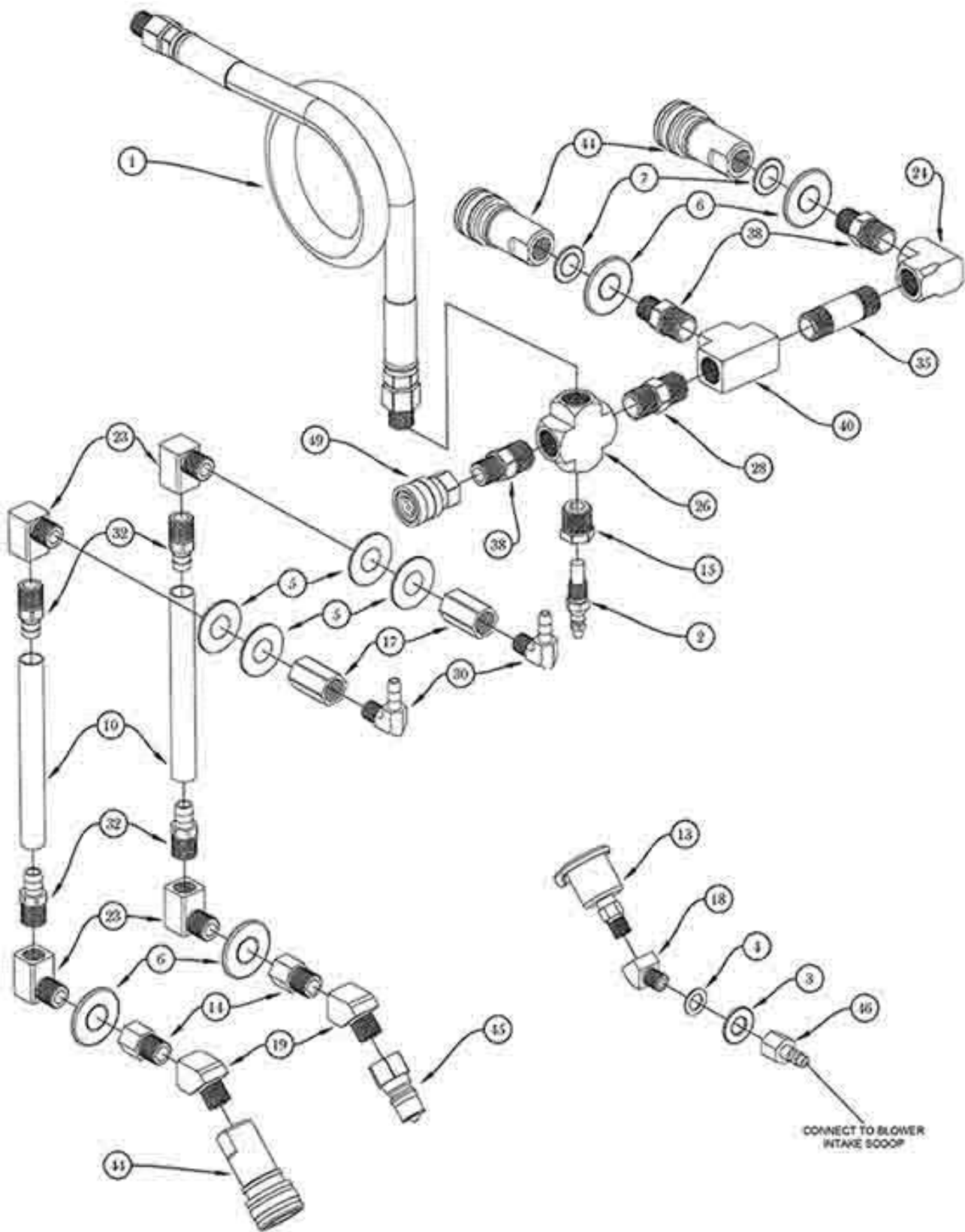

## PLUMBING ASSEMBLY (P. 1)

REF	PART NO.	DESCRIPTION	NOTES:
1	263-040	Hose ASSM, Temp(CV) C-Panel 3/8 X 19-1/2"	
2	360-206	Sender, Temp-Electronic	
3	415-135	FW, 3/8" SS	
4	415-137	FW, 3/8" AN SS	
5	415-155	FW, 1/2" SS	
6	415-156	FW, 1/2" Military	
7	415-157	FW, 1/2" AN SS	
8	415-165	FW, 5/8" SS	
9	425-115	Clamp, Hose Silicone	
10	480-015	PVC Tubing, 3/8" ID Clear	
11	530-105	Pulsar Unloader	
12	551-020	Valve, Temp Control	
13	551-075	Vac Lube Port	
14	555-002	ADPT, 1/4 M x 1/4 F	
15	555-022	Bushing, 3/8 M x 1/8 F	
16	555-074	Closed Nipple, 3/8"	
17	555-132	Coupling, 1/4"	
18	555-180	Elbow 45, 1/8" Street Extruded	
19	555-184	Elbow 45, Street 1/4"	
20	555-186	Elbow 45, 3/8" Street Extruded	
21	555-204	Elbow 90, 1/8" Street Forged	
22	555-206	Elbow 90, 1/4" FPT Extruded	
23	555-208	Elbow 90, 1/4" Street Extruded	
24	555-212	Elbow 90, 3/8" FPT	
25	555-214	Elbow 90, 3/8" Street Extruded	
26	555-242	Extruded Cross, 3/8"	
27	555-252	Ferrule, 1/4 Nylon Braid	
28	555-274	Hex Nipple, 3/8"	
29	555-320	Hose Barb 90, 1/4 Barb X 1/8 MPT	
30	555-324	Hose Barb 90, 3/8 Barb X 1/4 MPT	
31	555-350	Hose Barb, 1/4 Barb X 1/8 MPT	
32	555-364	Hose Barb, 3/8 Barb X 1/4 MPT	
33	555-390	Hose Barb, 5/8 Barb X 3/8 MPT	
34	555-430	Long Nipple, 3/8 X 1-1/2 "	
35	555-434	Long Nipple, 3/8 X 2"	
36	555-454	Plug, 3/8 MPT Hex Head	
37	555-456	Plug, 3/8" MPT (Countersunk)	
38	555-542	Reducing Nipple, 3/8 MPT X 1/4 MPT	
39	555-636	Tee, 1/4" Street Extruded	
40	555-640	Tee, 3/8" FPT.	
41	560-110	Brass Filter Check Valve 1/4"	
42	572-100	Clear Braided Hose 1/4"	
43	572-125	Pulse Hose, 3/8"	
44	580-010	Q.C. 1/4" Fem (Closed)	

## PLUMBING ASSEMBLY (P. 2)

45	580-015	Q.C. 1/4" Male (Closed)	
46	580-101	Q.C. 1/8" Male Shutoff	
47	580-106	Q.C. 1/8" Fem Shutoff	
48	580-110	Q.C. 1/8" Fem (Open)	
49	580-120	Q.C. 1/4" Fem (Open)	
50	580-125	Q.C. 1/4" Male (Open)	
51	580-140	Q.C. 3/8" Fem (Open)	
52	580-145	Q.C. 3/8" Male (Open)	
53	581-065	Crimp FTNG, 3/8" Pulse Hose 1/4 MPT SVL	
54	795-015	Lid, Jug 10 LT & 20 LT	

## PRESSURE REGULATOR DETAIL

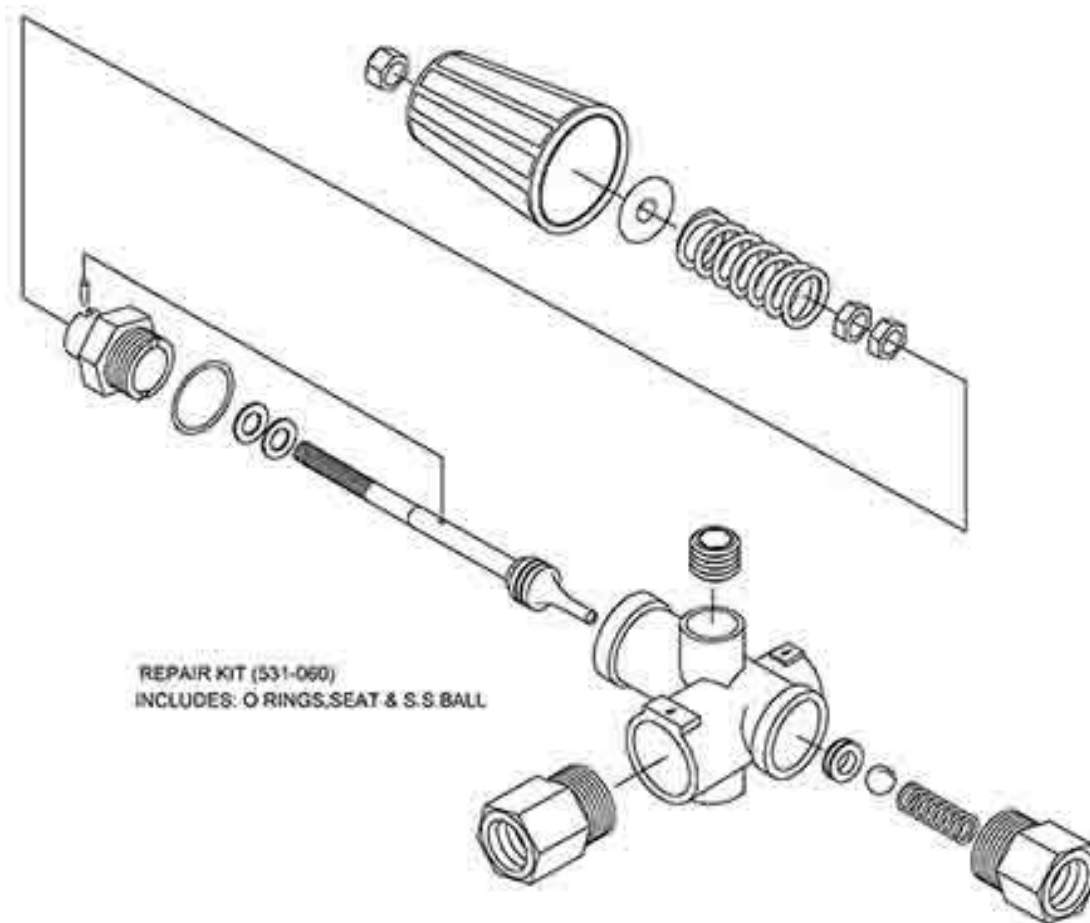



## COMPACT RECOVERY TANK COMPACT 45 & 47

REF	PART NO.	DESCRIPTION	NOTES:
1	305-105	Switch, Shut off / CAD	
2	325-303	Power Lock Terminal - Red	
3	325-305	Power Lock Terminal - Yellow	
4	325-320	Power Lock Insert	
5	560-315	Lid, Lint Basket Comp Rec Tank	
6	560-314	Lid, Filter Comp Rec Tank	
7	590-420	PVC Hose Barb, 2	
8	590-240	PVC Close Nipple 2"	
9	400-125	Lock Nut, 8 x 32 Nylon SS	
10	545-040	Ball Valve 2" Brass	
11	410-125	SMS, 8 x 5/8 Pan Rob SS	
12	410-130	MS, 8-32 x 1/2 Pan Phil SS	
13	420-151	Rivet, Fully Sealed #68 Al	
14	420-025	Rivet, Al #64	
15	425-116	Clamp, #10	
16	445-040	Catch, Rubber	
17	415-115	FW, 10 SS	
18	475-090	Gasket, Intake Rec. Tank	
19A	475-101	Gasket, Channel (Lint Basket)	
19B	475-103	Gasket, Channel (Filter)	
20	498-020	Plug, Rubber #10 C/W Tether	
21	620-405	Vac Breaker Assy	
22	498-103	Pad, Felt Disk	
23	550-035	Check Valve, 1/4 FM x FM	
24	555-208	Elbow 90, 1/4" Street Extruded	
25	555-272	Hex Nipple, 1/4"	
26	555-330	Hose Barb 90, 5/8 Barb x 3/8 MPT	
27	555-452	Plug, 1/4 MPT Hex	
28	555-636	Tee, 1/4 Street Extruded	
29	560-205	Filter, 2 1/2" S/S	
30	560-370	Filter Basket, Rec. Tank	
31	572-136	Hose, 5/8 Blue	
32	582-210	Plug, 1" Threaded	
33	582-212	Plug, 1-1/4" Threaded	
34	588-015	ABS Adpt 2", S x MPT	
35	590-025	Elbow 90, 2"	
36	595-010	ABS Pipe, 2" x 6"	
37	860-260	Rec. Tank 100 Comp.45/47/56	

# COMPACT BASEPLATE 45 & 47 (P. 1)

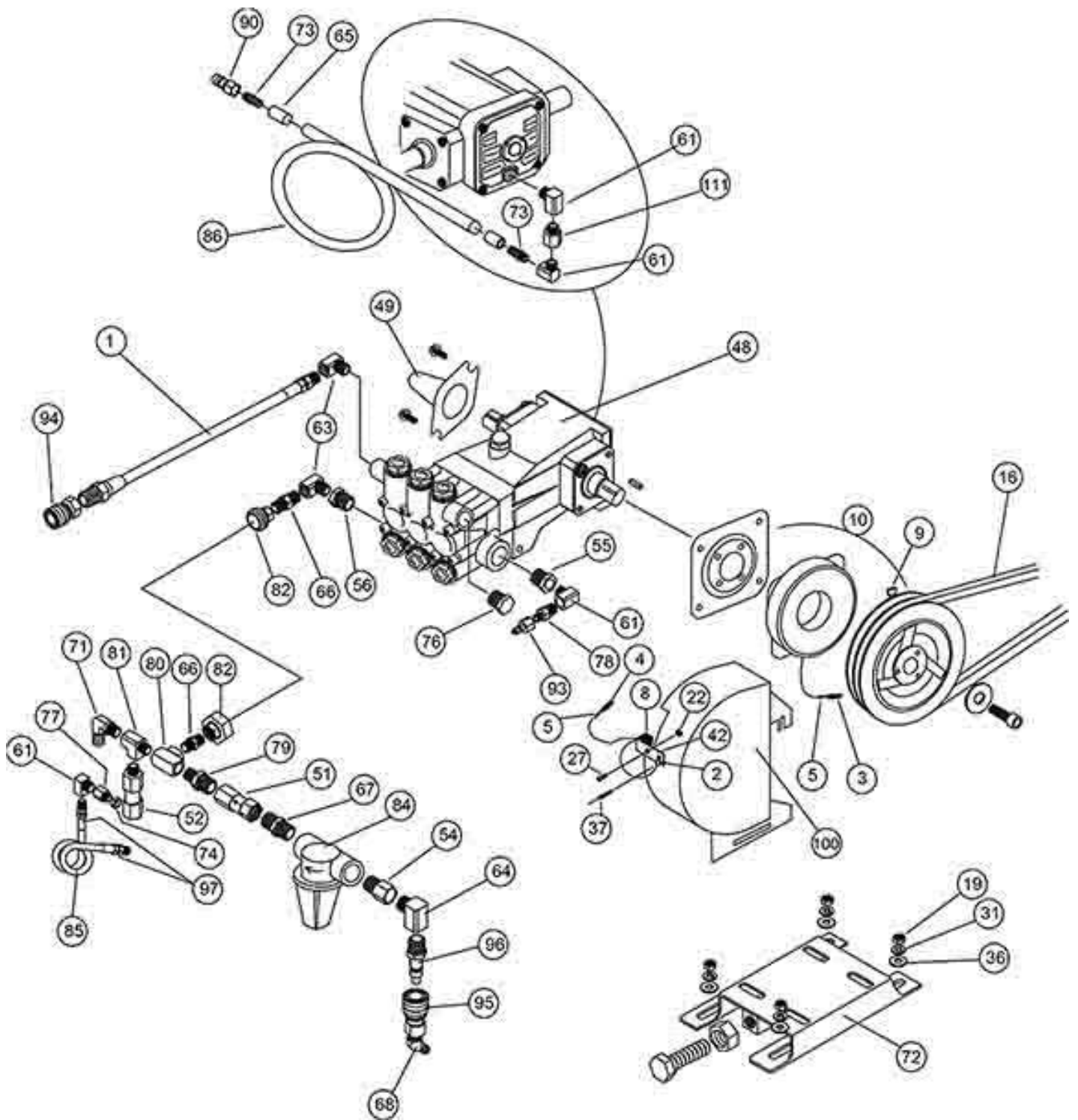

# COMPACT BASEPLATE 45 & 47 (P. 2)

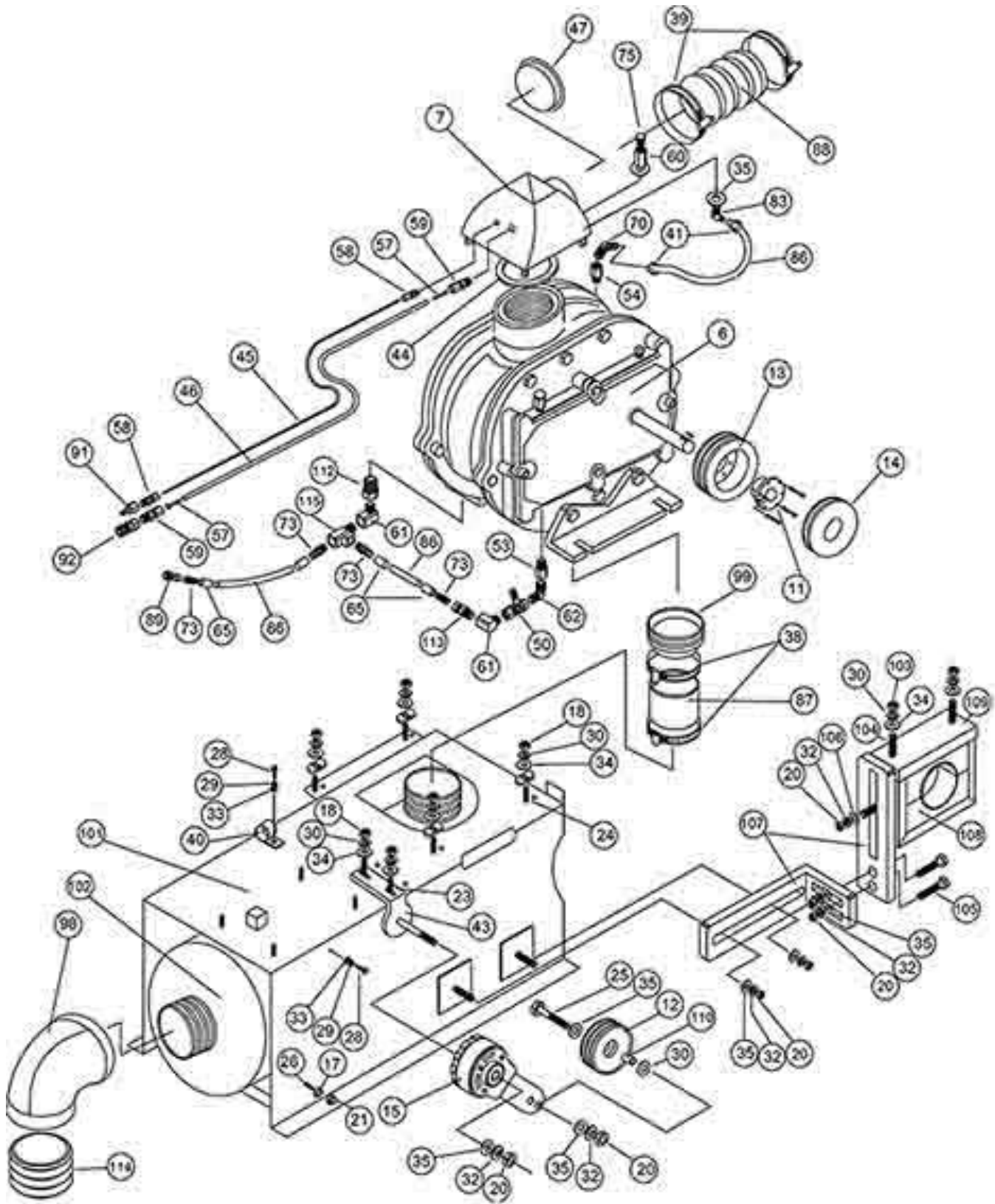



## COMPACT BASEPLATE 45 & 47 ( P. 1 )

REF	PART NO.	DESCRIPTION	NOTES:
1	263-045	Hose Assm 3/8 x 25"	
2	325-230	Blue Ring, 1/8	
3	325-300	Power Lock Terminal - Black	
4	325-315	Power Lock Terminal - Green	
5	325-320	Power Lock Insert	
6A	358-112	Roots 45 DSL Blower WHISPAIR	CP Baseplate 45
6B	358-122	Roots 47 DSL Blower WHISPAIR	CP Baseplate 47
7A	358-345	Intake Scoop 45 VR2	CP Baseplate 45
7B	358-347	Intake Scoop 47 VR2	CP Baseplate 47
8	360-221	Sender, Tach	
9	360-222	Magnet, Tach Sender	
10	365-041	Cat Clutch	
11	385-015	Bushing, H 7/8	
12	385-110	Pulley, Dual Idler C/W bushing 905-000	
13	385-121	Pulley, 2AK49H	
14	385-154	Pulley, 2.5	
15	390-145	Tensioner	
16	397-030	Belt, Compact Pump	
17	400-005	Hex nut, 1/4 x 20 SS	
18	400-015	Nut, 3/8 x 16 Zinc	
19	400-045	Hex Nut, 5/16 Zinc	
20	400-050	Hex Nut, 1/2 Zinc	
21	400-115	Locknut 1/4 x 20 Nylon SS	
22	400-125	Locknut, 8 x 32 Nylon SS	
23	405-110	Bolt 3/8 x 1 1/4 GR5 Zinc	
24	405-115	Bolt, 3/8 x 1 1/2 GR5 Zinc	
25	405-316	Bolt, 1/2 x 2-1/2 GRD 8	
26	405-600	Clinch Stud, 1/4 x 1 SS	
27	410-105	CS, 8 – 32 x 1/2 Soc SS	
28	410-250	Tek Screw, 1/4 x 1	
29	415-020	LW, 1/4 Zinc	
30	415-030	LW, 3/8 Zinc	
31	415-040	LW, 5/16 Zinc	
32	415-050	LW, 1/2 Zinc	
33	415-120	FW, 1/4 Zinc	
34	415-130	FW, 3/8 Zinc	
35	415-152	FW, 1/2 SAE Zinc	
36	415-200	FW, 5/16 Zinc	
37	420-025	Rivet AL/AL #64	
38A	425-035	Clamp, #48 Hose	CP Baseplate 45
38B	425-040	Clamp, #60 Hose	CP Baseplate 47
39	425-045	Clamp, #72 Hose	
40	425-140	Clamp, Tube 3/4"	
41	425-180	0 - Clamp 19/32	

## COMPACT BASEPLATE 45 & 47 ( P. 2 )

42	465-013	BRKT, Sensor	
43	465-652	Brkt, Tensioner V2	
44A	475-305	Gasket, 45 Intake Scoop	CP Baseplate 45
44B	475-310	Gasket, 47 Intake Scoop	CP Baseplate 47
45	480-100	Tubing, 1/8" Nylon	
46	480-105	Tubing, 1/4" Nylon	
47	498-080	Plug, 4-1/4"	
48	516-020	Cat Pump Model 5CP2120W	
49	516-210	Shaft Protector	
50	545-010	Ball Valve , 1/4"	
51	550-040	Check Valve, 1/2 FM x FM	
52	551-070	Thermal Valve, 3/8 NTP (140F)	
53	555-004	Adpt, 3/8 M x 3/8 F	
54	555-006	Adpt, 1/2 M x 1/2 F	
55	555-030	Bushing, 1/2 MPT x 1/4 FPT	
56	555-032	Bushing, 1/2 MPT x 3/8 FPT	
57	555-050	Brass Insert, 1/4 Synflex	
58	555-104	Comp. Fitting, 1/8 x 1/8 Male	
59	555-106	Comp. Fitting, 1/4 x 1/8 MPT	
60	555-132	Coupling, 1/4"	
61	555-208	Elbow 90, 1/4" Street Extruded	
62	555-210	Elbow 90, 3/8 MPT x 1/4 MPT	
63	555-214	Elbow 90, 3/8" Street Extruded	
64	555-218	Elbow 90, 1/2" Street Extruded	
65	555-250	Ferrule, .675 ID	
66	555-274	Hex Nipple, 3/8"	
67	555-276	Hex Nipple, 1/2"	
68	555-304	Hose Barb 45, 5/8 Barb x 3/8 MPT	
69	555-324	Hose Barb 90, 3/8 Barb x 1/4 MPT	
70	555-326	Hose Barb 90, 3/8 Barb x 3/8 MPT	
71	555-330	Hose Barb 90, 5/8 Barb x 3/8 MPT	
72	465-680	Pump Bracket	
73	555-364	Hose Barb, 3/8 Barb x 1/4 MPT	
74	555-406	Locknut, 1/8" Brass	
75	555-452	Plug, 1/4 MPT Hex	
76	555-454	Plug, 3/8 MPT Hex Head	
77	555-510	Reducing Adpt, 1/4 FPT x 1/8 MPT	
78	555-540	Reducing Nipple, 1/4 MPT x 1/8 MPT	
79	555-544	Reducing Nipple, 1/2 MPT x 3/8 MPT	
80	555-640	Tee, 3/8" FPT.	
81	555-642	Tee, 3/8" Street Extruded	
82	555-660	Union Coupling, 3/8" N	
83	555-928	Hose Barb 45, 3/8 Barb x 1/4 MPT	
84	560-113	Filter, Inline 1/2" (TM)	
85	572-042	Solution Hose, 1/4" Blue	
86	572-120	Heater Hose, 3/8" Silicone	

## **COMPACT BASEPLATE 45 & 47 ( P. 3 )**

87A	575-020	All Flex Hose, 2 7/8" ID	CP Baseplate 45
87B	572-220	Hose, 3 1/2" x 3" Silicone	CP Baseplate 47
88	575-038	Ducting Hose 4 1/2 ID x 6"	
89	580-010	Q.C. 1/4" Fem (Closed)	
90	580-015	Q.C. 1/4" Male (Closed)	
91	580-101	Q.C. 1/8" Male Shutoff	
92	580-106	Q.C. 1/8" Fem Shutoff	
93	580-115	Q.C. 1/8" Male (open) See Notes	
94	580-140	Q.C. 3/8" Fem (Open)	
95	580-200	Q.C. 3/8" Fem (One Way) Water	
96	580-205	Q.C. 3/8" Male (Open) Water	
97	581-015	Crimp Ftnq, 1/4" HP Hose - 1/4 MPT SVL	
98	582-007	Elbow 90, 2 1/2"	
99A	582-024	Close Nipple, 2 1/2 x 2 1/2 Blk Mal	CP Baseplate 45
99B	582-917	Nipple, 3" NPT x 4" Black Steel	CP Baseplate 47
100	845-313	Cover, Clutch	
101A	845-545	Baseplate, 45	CP Baseplate 45
101B	845-547	Baseplate, 47	CP Baseplate 47
102A	850-030	45 Silencer	CP Baseplate 45
102B	850-034	47 Silencer	CP Baseplate 47
103	400-030	Hex Nut 3/8 - 24 Zinc	
104	405-065	Bolt, 3/8 x 5 GR8 Zinc	
105	405-311	Bolt 1/2 x 1 3/4 GR8	
106	415-150	FW 1/2 Zinc	
107	465-291	Bracket PTO Rear	
108	498-225	Pillow Block, Rear Set	
109	845-640	Rear Pillow block Plate	
110	905-000	Bushing, 1/2 x 11/16 O.D	
111	555-002	ADPT, 1/4 M x 1/4 F	
112	555-024	Bushing, 3/8 M x 1/4 F	
113	582-080	Swivel, 1/4 M x 1/4 F	
114	582-025	Nipple 2 1/2" x 3.5"	
115	555-636	Tee, 1/4" Street Extruded	

**COMPACT PUMP KIT**

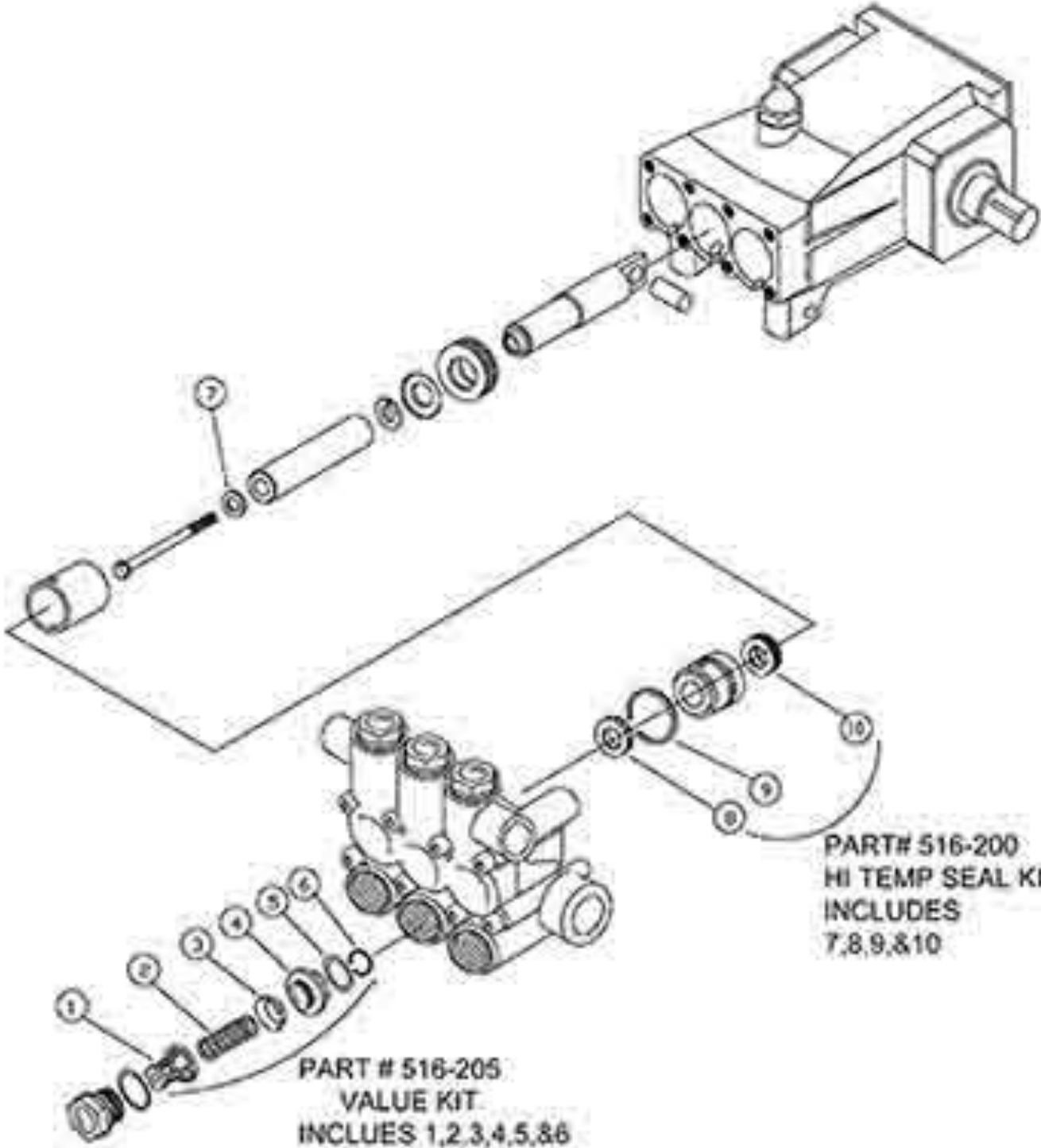

# KIT, INSTALLATION 45 & 47 (P. 1)



**KIT, INSTALLATION 45 & 47 (P. 2)**



## KIT, INSTALLATION 45 & 47(P. 1)

RE F	PART NO.	DESCRIPTION	QUANTITY
1	220-015	Holder Wand 2 Jet (Top & 12" BTM)	1 Set
2	220-410	Lock Up Thru Floor Hose Port	1
3	260-238-50	Vac Hose Blue 2"	5'
4	263-025	Hose ASSM, 43" Heat Exch	1
5	263-030	Hose ASSM, 48" Heat Exch	1
6	263-065	Prime Line, 4' ASSM 1/4"	1
7	315-009	Conduit , Plastic 1/4"	15'
8	320-105	Spot Light	2
9	350-108	Tie Strap, 14" Black	6
10	385-128	Pulley, 2AK74H	1
11	397-905	Belt, AX45	2
12	400-016	Nut, 3/8 Flanged	20
13	400-051	Nut, 1/2 GR8	4
14	405-115	Bolt, 3/8 x 1-1/2 GR5 Zinc	6
15	405-156	Bolt, 3/8 x 4 Allthread Zinc	4
16	405-185	Bolt 3/8 x 3 GR2 Zinc allthread	12
17	410-050	W.S., 6 x 1/2 FT RB Zinc	11
18	410-125	SMS, 8 x 5/8 Pan Rob, SS	14
19	410-252	Wafer Screw, SLF Tapping 3/4"	22
20	410-253	Wafer Screw, SLF Tapping 1 1/4"	15
21	415-050	LW, 1/2 Zinc	5
22	415-130	FW, 3/8 Zinc	14
23	415-375	Washer, 3/8 Timber	13
24	420-151	Rivet, Fully sealed #68	6
25	425-035	Clamp, #52	2
26	425-095	Clamp, 1/4 Tube Plastic	6
27	425-100	Clamp 1/2 Tube Plastic	5
28	425-116	Clamp, Hose Silicone #10	8
29	425-117	Clamp, Mikalor 3134 1"	8
30	425-135	Clamp, Tube 1-1/4"	3
31	425-235	Clamp, Rear PTO ASSY	1
32	445-030	Buckle, Doghouse	2
33	465-291	BRKT, PTO Rear Compact	1
34	545-005	Ball valve Mini 1/4	1
35	545-040	Ball Valve, 2" Brass -Fem, Pipe	1
36	572-136	Heater Hose, 5/8" Blue Hi-Miler	10'
37	572-140	Heater Hose, 1" Blue Hi-Miler	25
38	572-166	Formed Hose 3" Curved	1
39	579-040	Cuff, 2" Hose Grey	1
40	590-240	PVC Close Nipple	1
41	590-420	PVC Hose Barb 2" Barb x 2" MPT	1
42	600-055	Kit, Electrical	1
43	600-125	Kit, Muffler	1
44	703-371	Decal, Caution A/c & Heat	1

## **KIT, INSTALLATION 45 & 47 (P. 2)**

45	703-506A	Decal, cleanco Universal VR2	1
46	703-800	Maintenance Schedule, Cleanco	1
47	703-805	Operating Instructions, PTO	1
48	759-005	Chemical, Jug, 10LT	1
49	760-910	CD, Compact 45 & 47 Owner Manual	1



# DUAL HEAT EXCHANGER

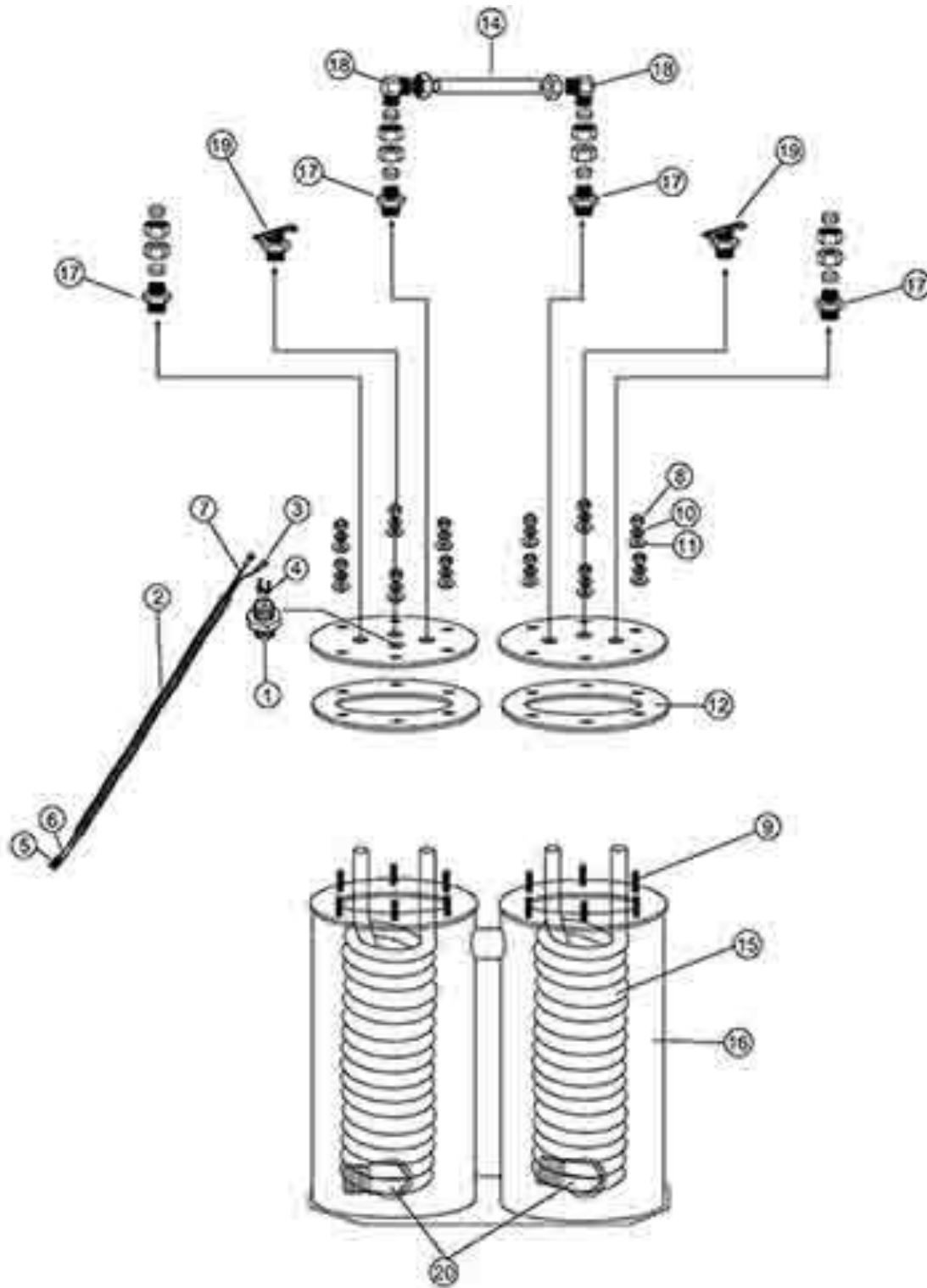

## DUAL HEAT EXCHANGER

REF	PART NO.	DESCRIPTION	NOTES:
1	305-070	Switch, High Limit (250F)	
2	315-010	Conduit, Plastic 1/2"	
3	325-230	Terminal ring #10 Blue	
4	325-240	Terminal 90 Fem. x Screw	
5	325-302	Power Lock Terminal Blue	
6	325-320	Power Lock Insert	
7	330-105	Wire 12 Ga. Yellow	
8	400-005	Hex Nut, 1/4 x 20 SS	
9	405-600	Clinch Stud, 1/4 x 1 S.S.	
10	415-025	LW, 1/4 SS	
11	415-125	FW, 1/4 SS	
12	475-085	Gasket, 5 3/4" Heat Exch.	
13	478-005	Insulation, 1" (By the SQ. FT)	Not Shown
14	480-235	S/S Tube, 1/2"	
15	485-100	Copper Coil, 3/8 x 25'	
16	490-105	Casing (Dual)	
17	555-114	Comp. Fitting, 3/8 x 3/8 MPT	
18	555-121	Comp. Fitting 90, 1/2 x 3/8	
19	555-164	Drain Cock, 1/4" Brass	
20	555-335	Hose Barb 90, 1" Barb x 1" MPT	

P.T.I.

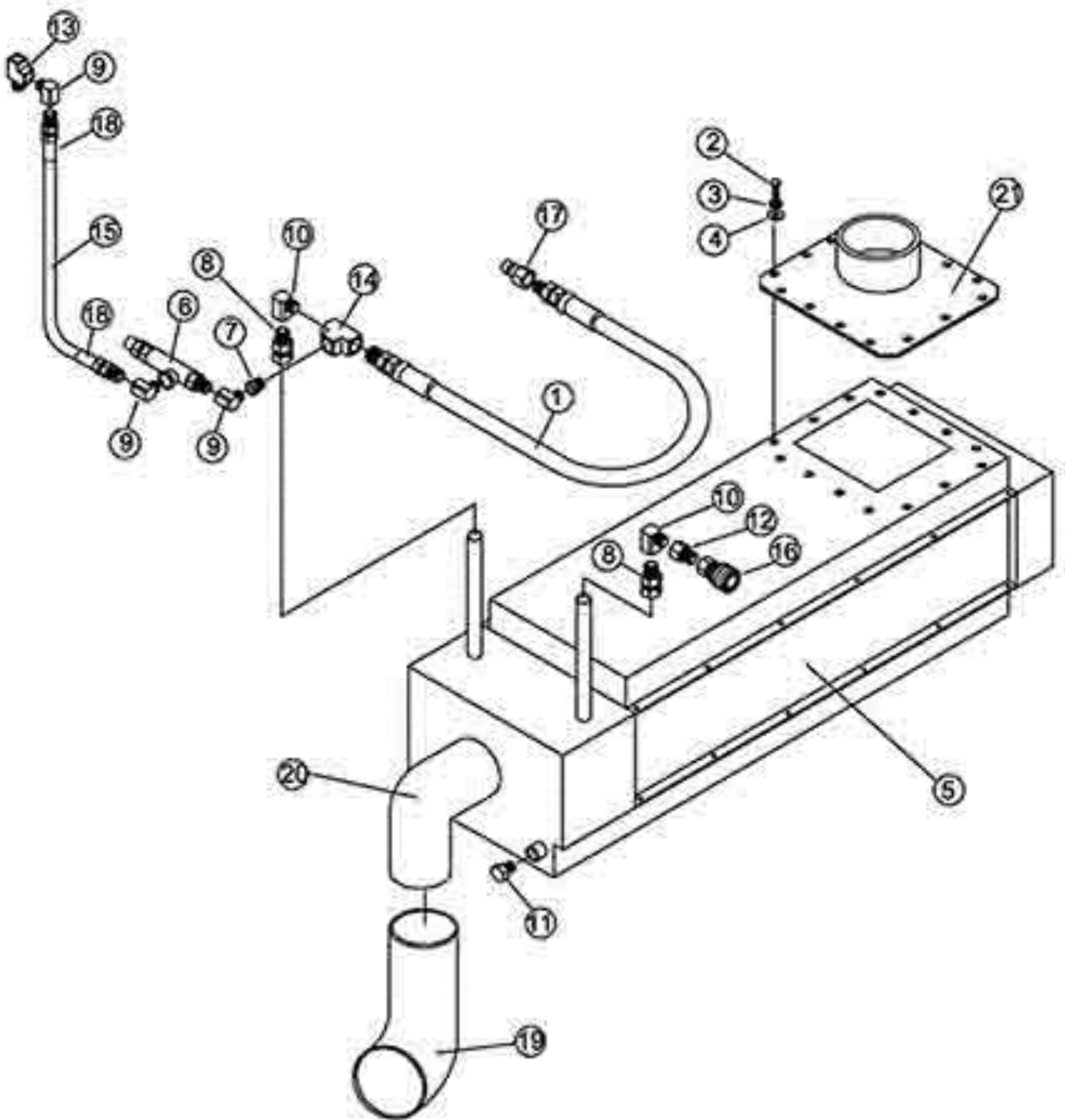

## POST THERMAL INCREASE ( P.T.I.)

REF	PART NO.	DESCRIPTION	NOTES:
1	263-046	Hose PTI X Panel 3/8 x 18.5"	
2	405-620	CS, 1/4 x 3/4 SS(Hex HD)	
3	415-025	LW, 1/4 SS	
4	415-125	FW, 1/4 SS	
5	490-150	Post Heat Coil	
6	551-005	Valve, Press. Limiter - 1200 PSI	
7	555-024	Bushing, 3/8 M x 1/4 F	
8	555-126	Comp. Tube FTG SS 5/8T x 3/8 NPT	
9	555-208	Elbow 90, 1/4" Street Extruded	
10	555-214	Elbow 90, 3/8" Street Extruded	
11	555-452	Plug, 1/4 MPT Hex	
12	555-512	Reducing ADPT, 3/8 FPT x 1/4 MPT	
13	555-636	Tee, 1/4" Street Extruded	
14	555-640	Tee, 3/8" FPT.	
15	572-042	Solution hose, 1/4" Blue Neptune HP	
16	580-120	Q.C. 1/4 Female (Open)	
17	580-125	Q.C. 1/4 Male (Open)	
18	581-015	Crimp Fitting, 1/4 HP Hose – 1/4 MPT SVL	
19	572-166	Formed Hose 3" Curved	
20	582-009	Elbow 90, 3" x 3"	
21A	845-016	Adapter Plate (45 PTI)	
21B	845-017	Adapter Plate (47 PTI)	
21C	845-018	Adapter Plate (56 PTI)	

# COVER & HOLDER KIT

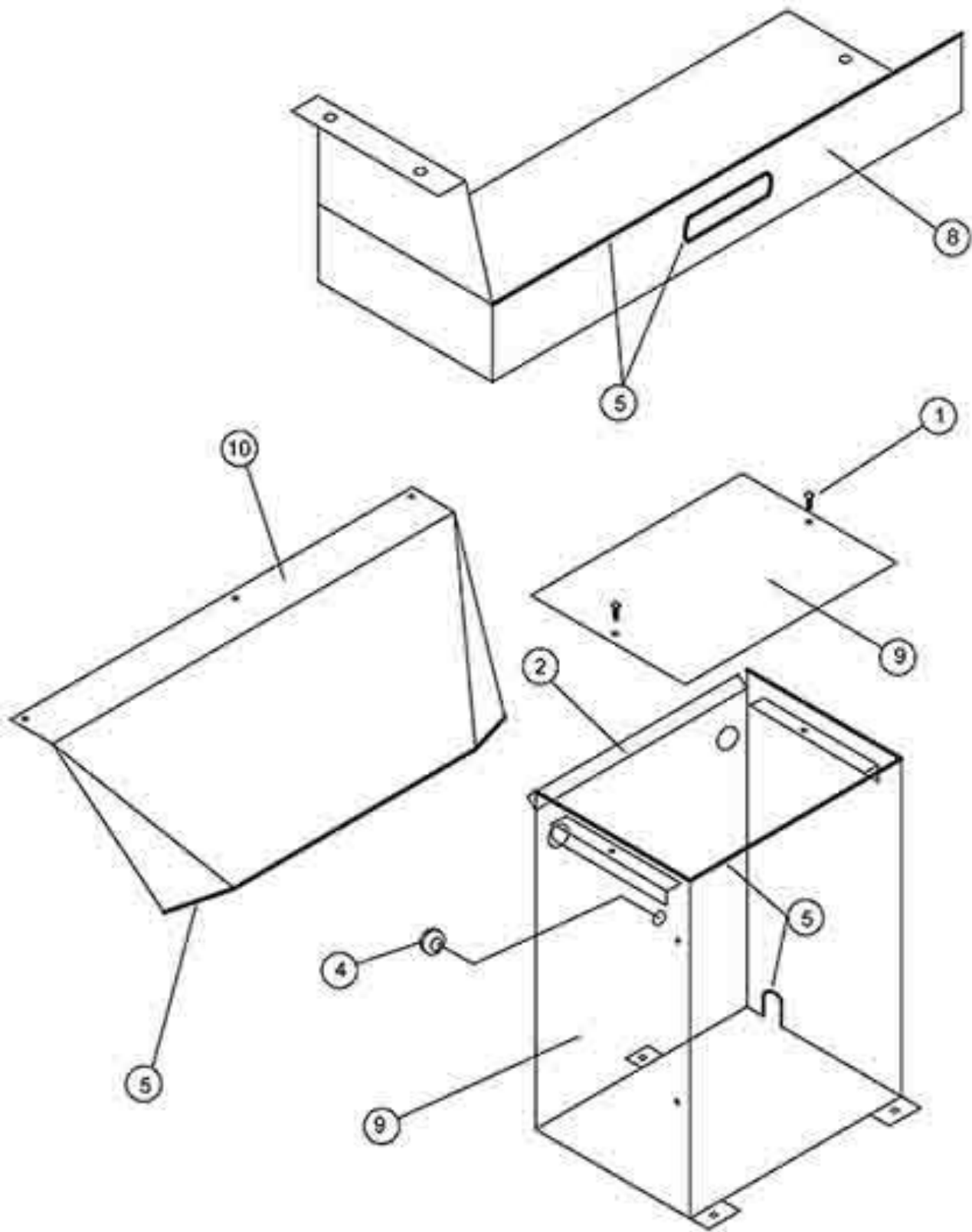

## COVER & HOLDER KIT

REF	PART NO.	DESCRIPTION	NOTES:
1	410-130	MS, 8-32 x 1/2 Pan Phil SS	
2	475-100	Gasket, channel	
3	478-010	Insulation, Heat Exchanger Cover	Not Shown
4	498-035	Grommet, Rubber 11/16	
5	499-005	Trim 1/2 Black	
6	703-225	Decal, Warning – Rotating Machinery	Not Shown
7	703-506A	Decal, Compact	Not Shown
8	845-271	Tank Shelf	
9	845-275	Cover, heat Exch Dual	
10	845-285	Cover, Transition	

## PTO SHAFT

Clutch 6" - 365-010



## PTO SHAFT ASSEMBLY

REF	PART NO.	DESCRIPTION	NOTES:
1	230-362	PTO Shaft Assy VR SB 62"	
2	230-364	PTO Shaft Assy VR SB 64"	
3	230-367	PTO Shaft Assy VR SB 67"	
4	230-370	PTO Shaft Assy VR SB 70"	
5	230-375	PTO Shaft Assy VR SB 75"	

## CAD PANEL MOUNT OPTION

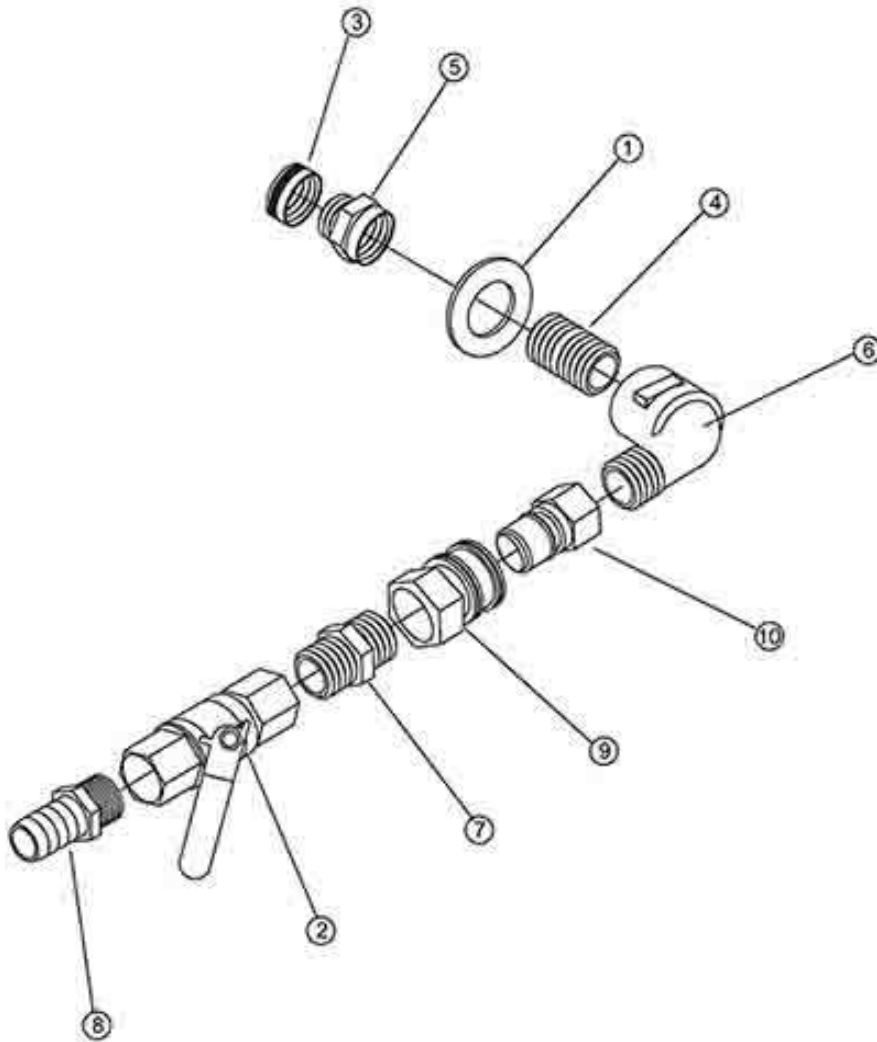

REF	PART NO.	DESCRIPTION	NOTES:
1	415-195	FW, 1" S.S.	
2	545-035	Ball Valve 3/4"	
3	555-025	Cap Nut	
4	555-079	Close Nipple 3/4 short	
5	555-144	Coupling, M.Hose to 3/4" FTP	
6	555-222	Elbow 90, 3/4" Street Forged	
7	555-278	Hex Nipple 3/4"	
8	555-400	Hose Barb, 1 Barb x 3/4 MPT	
9	580-170	Q.C 3/4 FEM. (Open)	
10	580-175	Q.C 3/4 Male (Open)	



# C.A.D. EXTERNAL OPTION PAGE 1

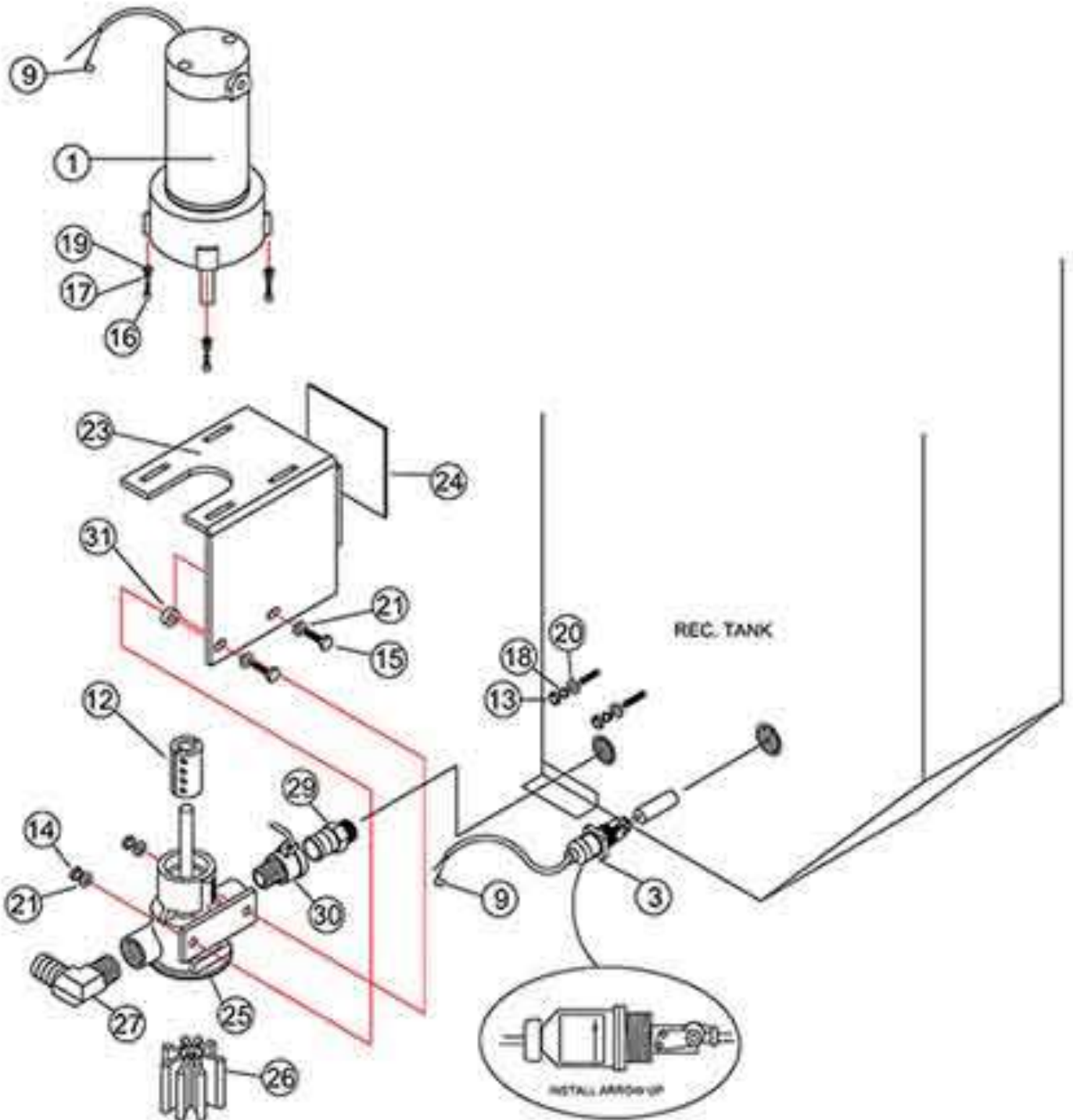

# C.A.D. EXTERNAL OPTION PAGE 2

## C.A.D. EXTERNAL WIRING

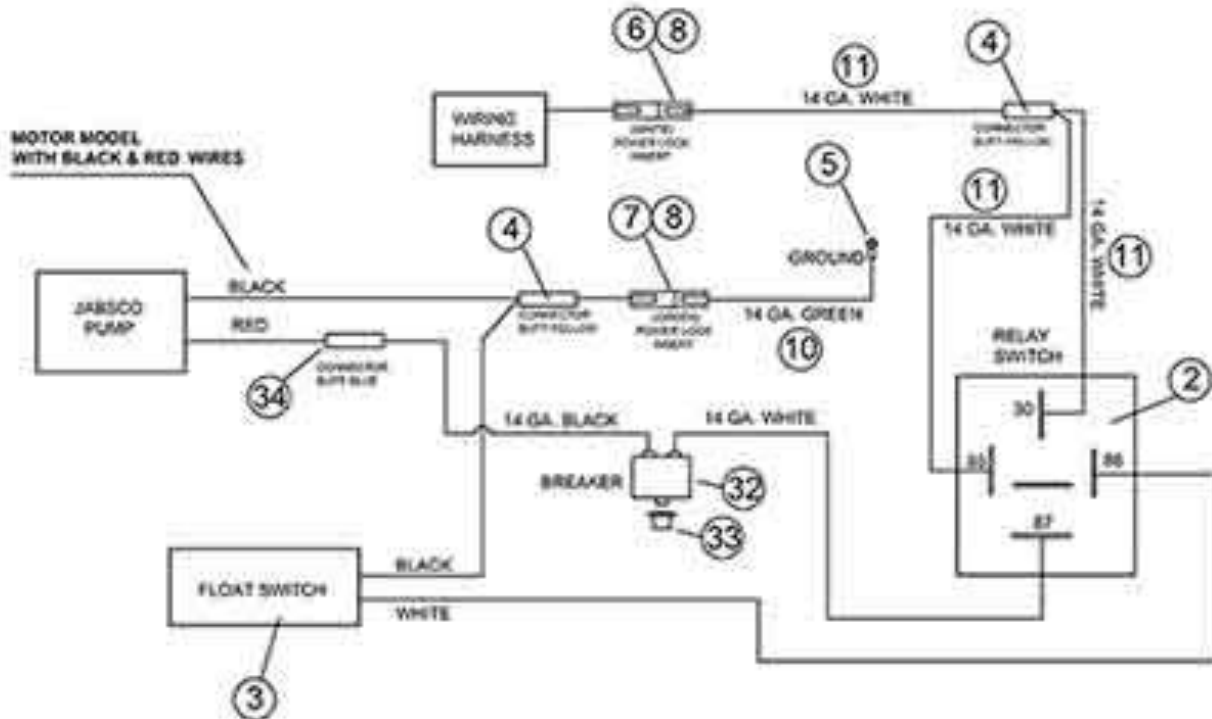
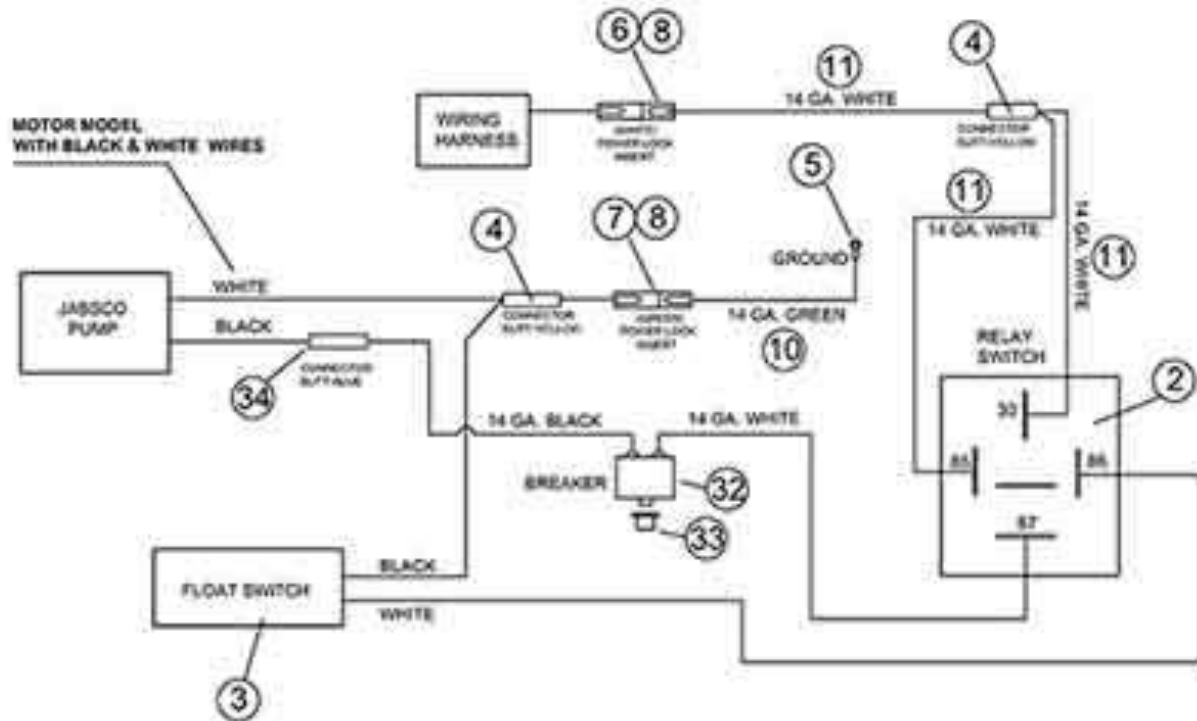

## C.A.D. EXTERNAL PARTS LIST

REF	PART NO.	DESCRIPTION	NOTES:
1	300-065	Motor, 12 volt DC Gear	
2	305-055	Relay	
3	305-105	Switch, External C.A.D.	
4	325-010	Connector, Butt -Yellow	
5	325-205	Terminal Ring 1/4 Blue	
6	325-310	Power Lock Terminal - White	
7	325-315	Power Lock Terminal - Green	
8	325-320	Power Lock Insert	
9	325-500	Spade, 1/4 FEM. 90 Crimp	
10	330-230	Wire 14 GA. Green	
11	330-235	Wire 14 GA. White	
12	380-518	Coupling Shaft 3/4 x 5/8	
13	400-015	Nut, 3/8 x 16 Zinc	
14	400-100	Locknut, 3/8 x 16 Nylon Zinc	
15	405-115	Bolt, 3/8 x 1 1/2 GR5 Zinc	
16	405-452	Bolt, 1/4 x 3/4 soc NF	
17	415-025	LW, 1/4 SS	
18	415-030	LW, 3/8 Zinc	
19	415-125	FW, 1/4 SS	
20	415-130	FW, 3/8 Zinc	
21	415-135	FW, 3/8 SS	
22	425-010	Clamp, #20	Not Shown
23	465-046	Bracket, External C.A.D.	
24	475-070	Gasket, 1/8" x 10"	
25	525-025	JABSCO Pump	
26	525-026	Pump Impeller	
27	555-335	Hose Barb 90, 1" Barb x 1" MPT	
28	572-157	Polyspring Hose 1"	Not Shown
29	580-300	Q.C. Cam-lock FM	
30	580-305	Q.C. Cam- lock M	
31	906-109	Spacer, JABSCO Pump	
32	340-162	Breaker 15A	
33	906-109	Boot, Seal Breaker	
34	325-005	Connector, Butt -Blue	

# HORIZONTAL F/W TANK 120 GALLON

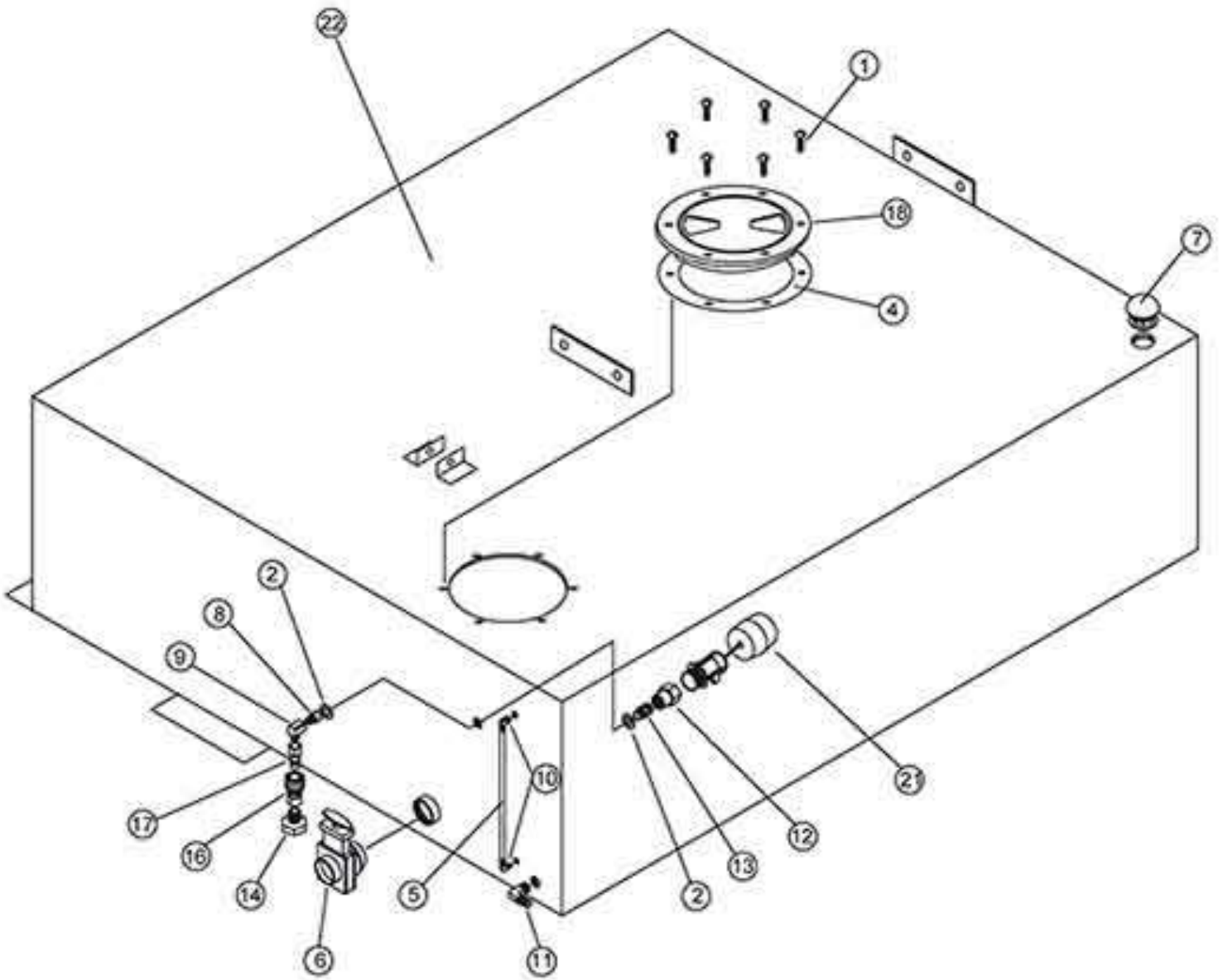

## HORIZONTAL F/W TANK 120 GALLON

REF	PART NO.	DESCRIPTION	NOTES:
1	410-135	MS, 8 - 32 x 3/4 Pan Head S.S.	
2	415-165	FW, 5/8 SS	
3	425-005	Clamp, #8 Hose 1/2 x 1	Not Shown
4	475-125	Gasket, 6" Access Cover	
5	480-010	PVC Tubing, 1/4" ID Clear	
6	545-100	Dump Valve, 1 1/2" (Flange-MPT)	
7	550-004	Air Valve 1"	
8	555-004	Adpt, 3/8 M x 3/8 F	
9	555-214	Elbow 90, 3/8" Street Extruded	
10	555-322	Hose Barb 90, 1/4 Barb x 1/4 MPT	
11	555-330	Hose Barb 90, 5/8 Barb x 3/8 MPT	
12	555-516	Reducing Adpt, 3/4 MPT x 1/2 F	
13	555-544	Reducing Nipple, 1/2 MPT x 3/8 MPT	
14	555-605	Swivel, 3/8 MPT x F SVL	
15	555-670	Washer, - Cap Nut	
16	580-130	Q.C. 3/8" Fem (Closed)	
17	580-135	Q.C. 3/8" Male (Closed)	
18	585-210	Clear Cover, 6" C/W Ring	
19	588-020	ABS Elbow 45, 1 1/2" SLP x SLP	Not Shown
20	595-005	ABS Pipe, 1 1/2"	Not Shown
21	597-065	Valve, Diaphragm	
22	860-258	F/W Tank, Horizontal 120 Gallon	

# F/W TANK AQUA STORAGE 120 GALLON

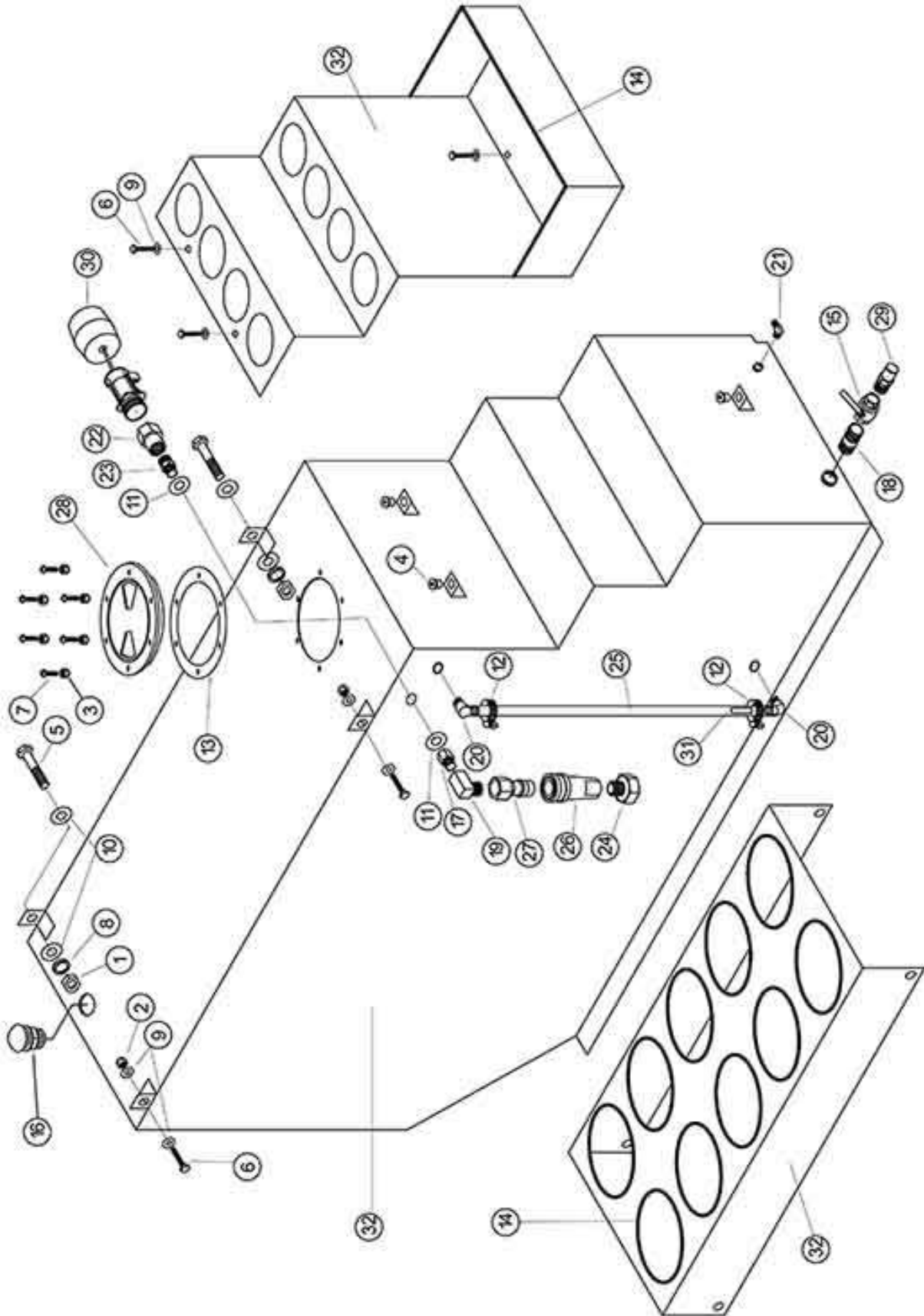

## F/W TANK AQUA STORAGE 120 GALLON

REF	PART NO.	DESCRIPTION	NOTES:
1	400-015	Nut, 3/8 x 16 Zinc	
2	400-115	Locknut, 1/4 x 20 Nylon SS	
3	400-125	Locknut, 8 x 32 Nylon SS	
4	400-250	Well Nut, 1/4 x 20 Neoprene	
5	405-132	Bolt, 3/8 x 2 SS	
6	405-620	CS, 1/4 x 3/4 SS	
7	410-135	MS, 8-32 X 3/4 Pan Head SS	
8	415-030	LW, 3/8 Zinc	
9	415-125	FW, 1/4 SS	
10	415-135	FW, 3/8 SS	
11	415-165	FW, 5/8 SS	
12	425-115	Clamp, Hose Silicone	
13	475-125	Gasket, 6" Access Cover - Clear	
14	499-005	Trim, 1/2" Black	
15	545-036	Ball Valve 1"	
16	550-004	Air Valve 1"	
17	555-004	ADPT, 3/8 M x 3/8 F	
18	555-080	Close Nipple 1"	
19	555-214	Elbow 90, 3/8" Street Extruded	
20	555-324	H. Barb 90, 3/8 Barb x 1/4 MPT	
21	555-330	H. Barb 90, 5/8 Barb x 3/8 MPT	
22	555-516	Red. ADPT, 3/4 MPT x 1/2 F	
23	555-544	Red. Nipple, 1/2 MPT x 3/8 MPT	
24	555-605	Swivel, 3/8 MPT x F SVL	
25	572-106	Clear Hose, 1/2 ID	
26	580-130	Q.C. 3/8" FEM (Closed)	
27	580-135	Q.C. 3/8" MALE (Closed)	
28	585-210	Clear Cover, 6" C/W Ring	
29	590-404	PVC Hose Barb 1"	
30	597-065	Valve, Diaphragm - Auto Fill	
31	597-075	Float, Plastic Site	
32	860-305	F/W Tank, C/W Holders	

# ELECTRIC HOSE REEL SET

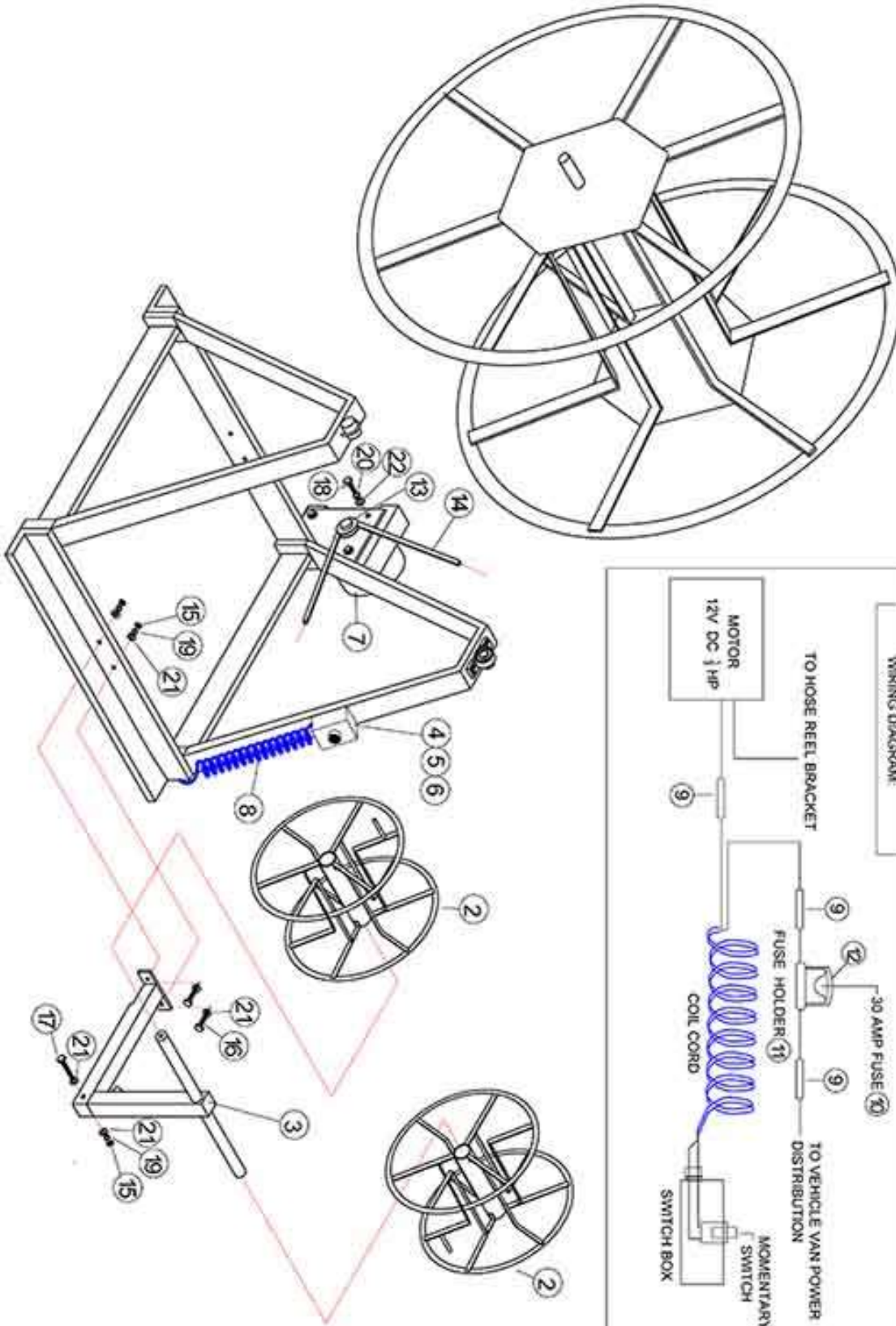



## ELECTRIC HOSE REEL SET

REF	PART NO.	DESCRIPTION	NOTES:
1	235-030	Hose Reel Set (vac & Solution)	
2	235-015	Solution Hose Reel	
3	235-150	Stand dual solution Reel	
4	620-412	Switch Box ASSY	
5	305-945	Switch Box Cover	
6	305-950	Switch Momentary	
7	300-060	Motor, 12V DC 1/3HP	
8	315-100	Cord, Coil 10'	
9	325-010	Connector, Butt -Yellow	
10	340-105	Fuse 30 Amp	
11	345-105	Fuse Holder	
12	345-115	Fuse Holder Cover	
13	385-149	Pulley, AK20 5/8	
14	397-110	Belt A114	
15	400-015	Nut, 3/8 x 16 Zinc	
16	405-110	Bolt, 3/8 x 1 1/4 GR5 Zinc	
17	405-185	Bolt, 3/8 x 3 GR2 Zinc All thread	
18	405-210	Bolt, 5/16 x 1 GR5 Zinc	
19	415-030	LW, 3/8 Zinc	
20	415-040	LW, 5/16 Zinc	
21	415-130	FW, 3/8 Zinc	
22	415-200	FW, 5/16 Zinc	

# F/W TANK AQUA - REEL TANK (125 GAL) P. 1

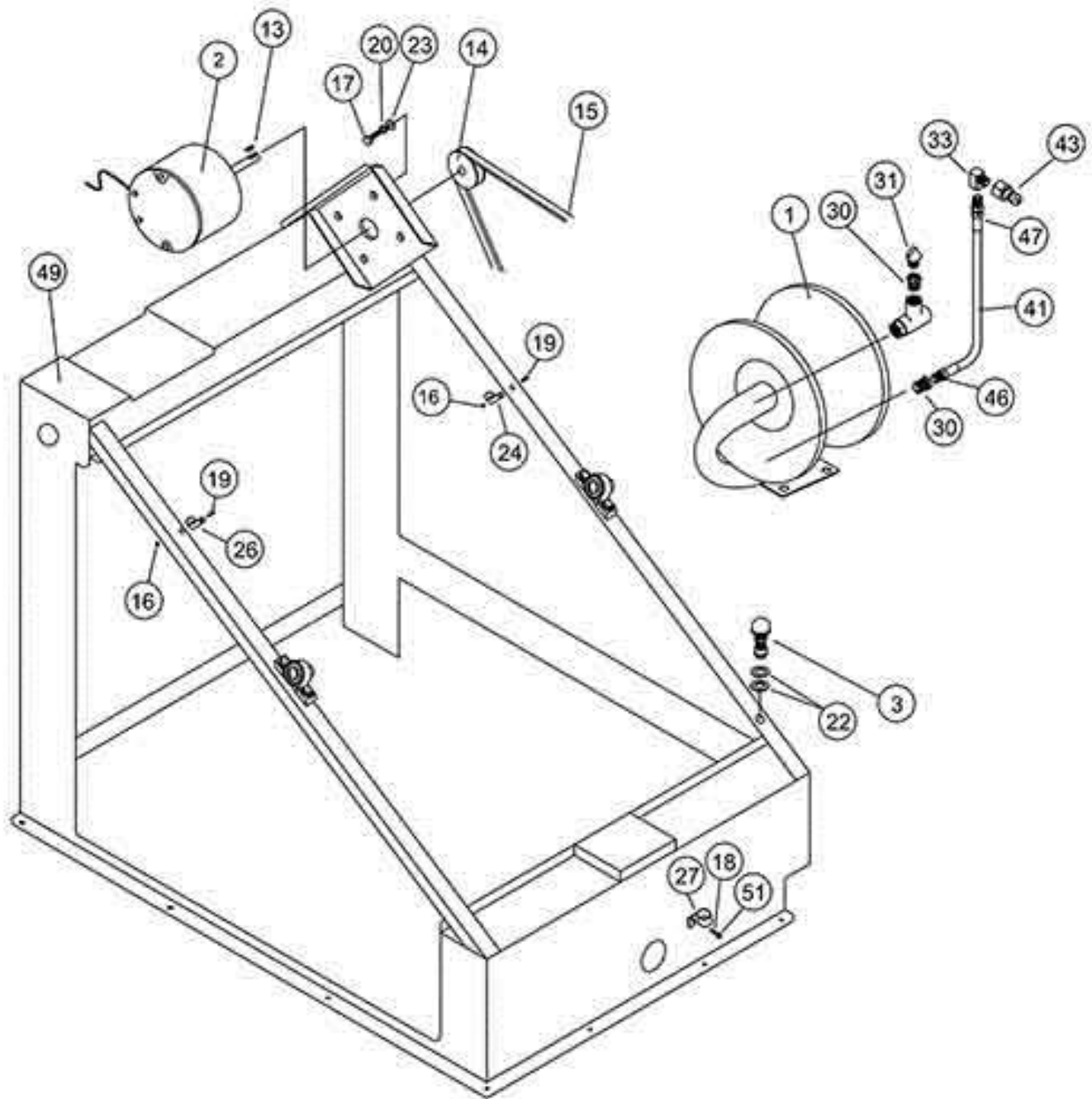

## F/W TANK AQUA - REEL TANK (125 GAL) P. 2

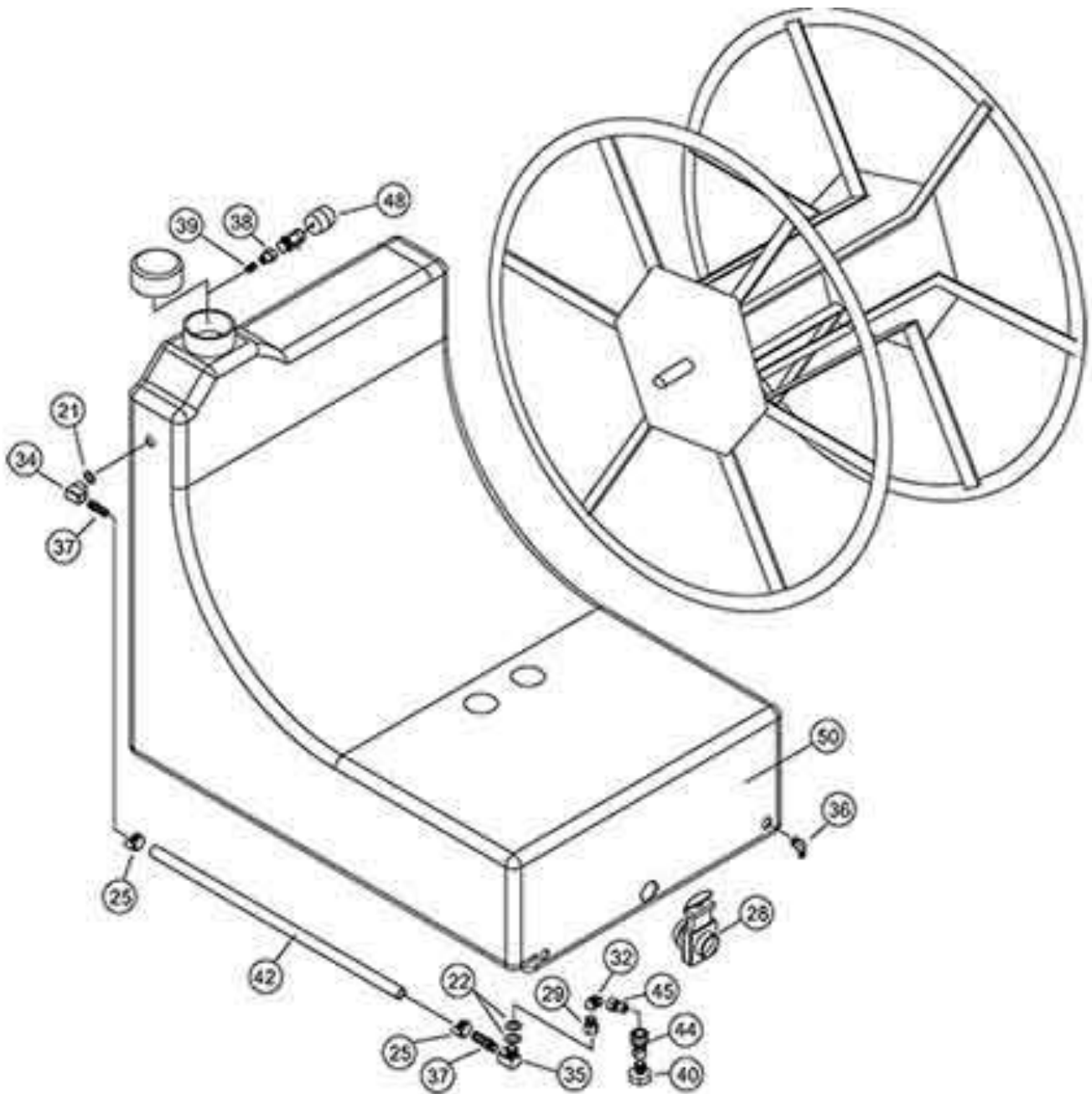

## F/W TANK AQUA - REEL TANK (125 GAL) P. 3

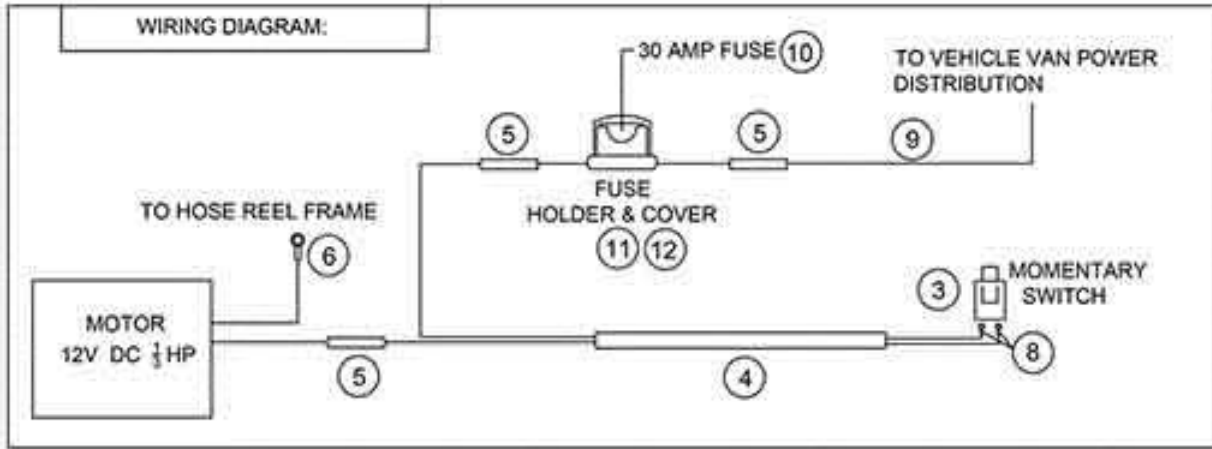

## F/W TANK AQUA - REEL TANK (125 GAL) PARTS

REF	PART NO.	DESCRIPTION	NOTES:
1	235-305	Hose Reel Solution 200'	
2	300-060	Motor, 12V DC 1/3HP	
3	305-125	Switch Momentary 35A	
4	315-035	Cord	
5	325-010	Connector, Butt -Yellow	
6	325-211	Terminal Ring, 5/16" - Yellow	
7	325-215	Terminal Ring, 3/8" - Blue	
8	325-225	Terminal Ring, #10 - Yellow	
9	330-005	Wire, 10A - Red	
10	340-105	Fuse 30 Amp	
11	345-105	Fuse Holder	
12	345-115	Fuse Holder Cover	
13	380-580	Key, Woodruff 3/16 x 1/2"	
14	385-149	Pulley, AK20 5/8	
15	397-105	Belt, A104	
16	400-125	Locknut, 8 x 32 Nylon S.S	
17	405-210	Bolt, 5/16 x 1 GR5 Zinc	
18	405-610	Clinch Stud, 1/4 x 3/4 S.S	
19	410-130	MS, 8-32 x 1/2 Pan Phil S.S	
20	415-040	LW, 5/16 Zinc	
21	415-165	FW, 5/8 S.S	
22	415-166	FW, 5/8 S.S AN	
23	415-200	FW, 5/16 Zinc	
24	425-100	Clamp, 1/2 Tube Plastic	
25	425-116	Clamp, Hose Silicone #10	
26	425-137	Clamp, tube 1"	

27	425-140	Clamp, tube 3/4"	
28	545-100	Dump valve, 1-1/2"	
29	555-004	ADPT, 3/8 M x 3/8 F	
30	555-024	Bushing 3/8 M x 1/4 F	
31	555-184	Elbow 45, Street 1/4"	
32	555-186	Elbow 45, 3/8" Street Extruded	
33	555-208	Elbow 90, 1/4" Street Extruded	
34	555-212	Elbow 90, 3/8" FPT	
35	555-214	Elbow 90, 3/8" Street Extruded	
36	555-331	Hose Barb 90, 5/8 Barb x 1/2 MPT	
37	555-390	Hose Barb, 5/8 Barb x 3/8 MPT	
38	555-516	Reducing ADPT, 3/4 MPT x 1/2 F	
39	555-544	Reducing Nipple, 1/2 MPT x 3/8 MPT	
40	555-605	Swivel, 3/8 MPT x F SVL (Water)	
41	572-042	Blue Neptune, 1/4	
42	572-136	Heater Hose, 5/8 Silicone	
43	580-015	Q.C. 1/4" Male (Closed)	
44	580-130	Q.C. 3/8" FEM (Closed)	
45	580-135	Q.C. 3/8" Male (Closed)	
46	581-010	Crimp Fitting, 1/4" HP Hose - 1/4" MPT	
47	581-015	Crimp Fitting, 1/4" HP Hose - 1/4" MPT SVL	
48	597-065	Valve, Diaphragm -Auto fill	
49	845-600	Frame & Vac Reel, Poly Tank	
50	860-315	Poly Tank 125 Gal (White)	
51	400-115	Locknut 1/4 x 20 S.S	

## CLEANCO 2 – JET WAND (250-055)

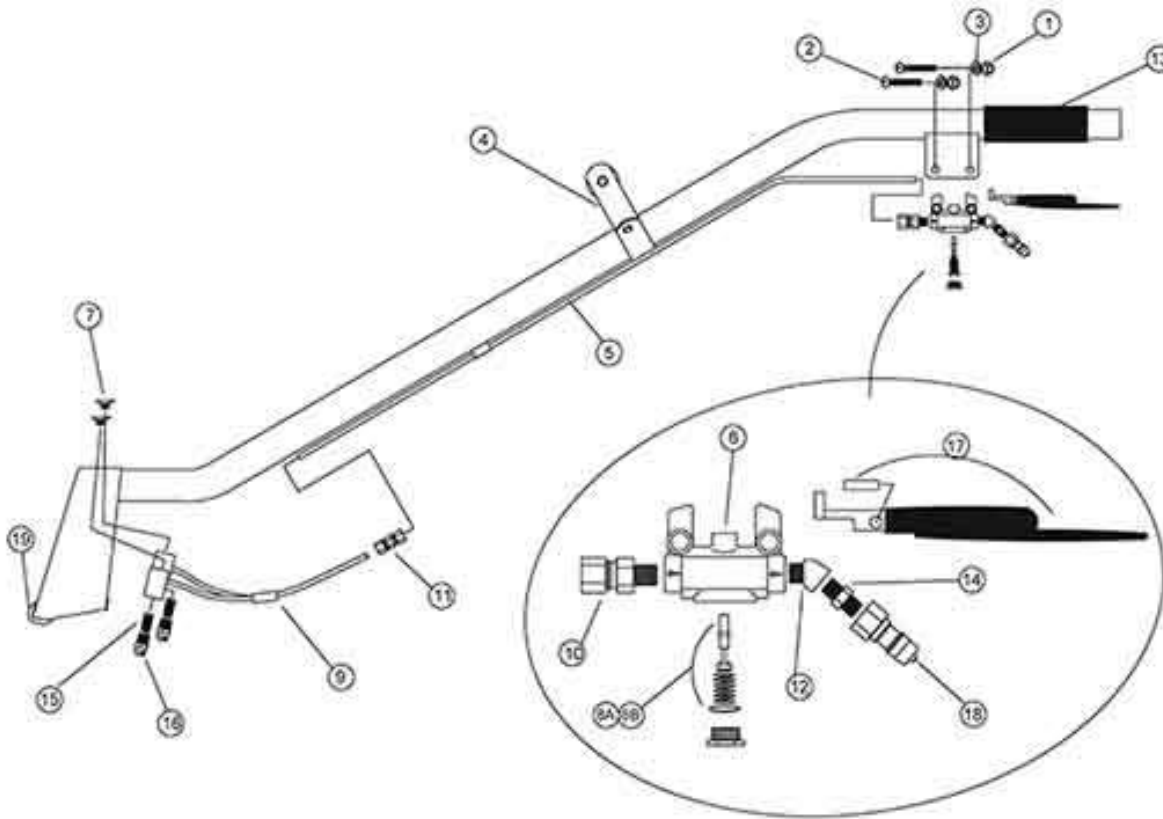

REF	PART NO.	DESCRIPTION	NOTES:
1	400-210	Acorn nut, 1/4 x 20 Zinc	
2	410-015	MS, 1/4 x 1 3/4 RH Rob Zinc	
3	415-020	LW, 1/4 Zinc	
4	435-030	D Handle	
5	480-200	Tubing, 1/4 O.D S.S	
6	535-020	Valve, Para Plate	
7	538-421	Machine Screw	
8A	539-005	Repair Kit	
8B	539-010	Seal Kit	
9	553-105	Manifold 2 jet	
10	555-108	Comp Fitting 1/4 x 1/4 MPT	
11	555-116	Comp Union Coupling 1/4 x 1/4	
12	555-184	Elbow 45, Street 1/4"	
13	555-200	Vinyl Grip 1 1/2" x 6" Black	
14	555-272	Hex Nipple, 1/4"	
15	560-005	Screen, 1/4" Vee Jet	
16	561-130	Vee Jet, 1/4" 110015 S.S	
17	566-032	Trigger, Paraplate	
18	580-015	Q.C 1/4" Male (Closed)	
19	552-040	Wand glide	

## CLEANCO SINGLE – JET WAND (250-065)

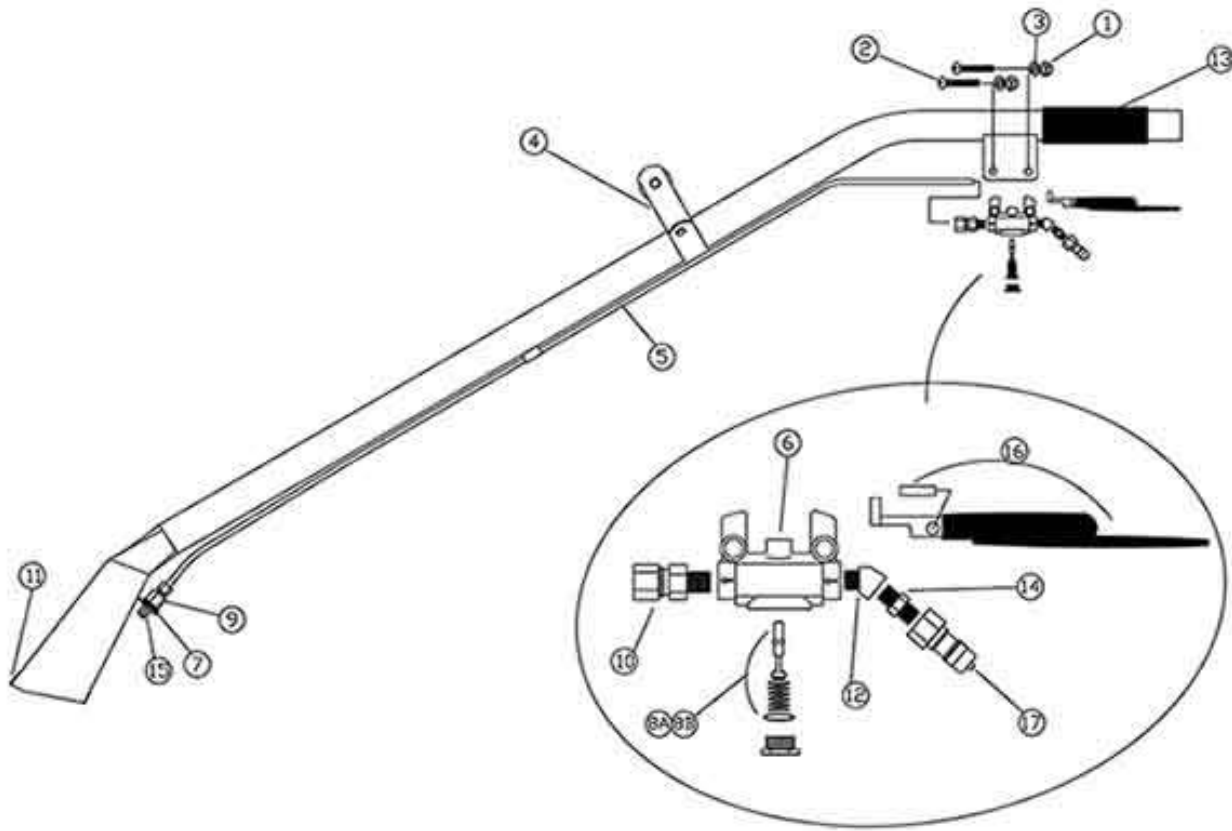

REF	PART NO.	DESCRIPTION	NOTES:
1	400-210	Acorn nut, 1/4 x 20 Zinc	
2	410-015	MS, 1/4 x 1 3/4 RH Rob Zinc	
3	415-020	LW, 1/4 Zinc	
4	435-030	D Handle	
5	480-200	Tubing, 1/4 O.D S.S	
6	535-020	Valve, Para Plate	
7	538-322	Spacer, Jet (ABS)	
8A	539-005	Repair Kit	
8B	539-010	Seal Kit	
9	555-912	1/4 PT x 1/4 Compression Fitting	
10	555-108	Comp Fitting 1/4 x 1/4 MPT	
11	552-025	Wand Glides	
12	555-184	Elbow 45, Street 1/4"	
13	555-200	Vinyl Grip 1 1/2" x 6" Black	
14	555-272	Hex Nipple, 1/4"	
15	561-110	Vee Jet 11003	
16	566-032	Trigger, Paraplate	
17	580-015	Q.C 1/4" Male (Closed)	

## 30" SWIVEL STAIR TOOL (255-110)

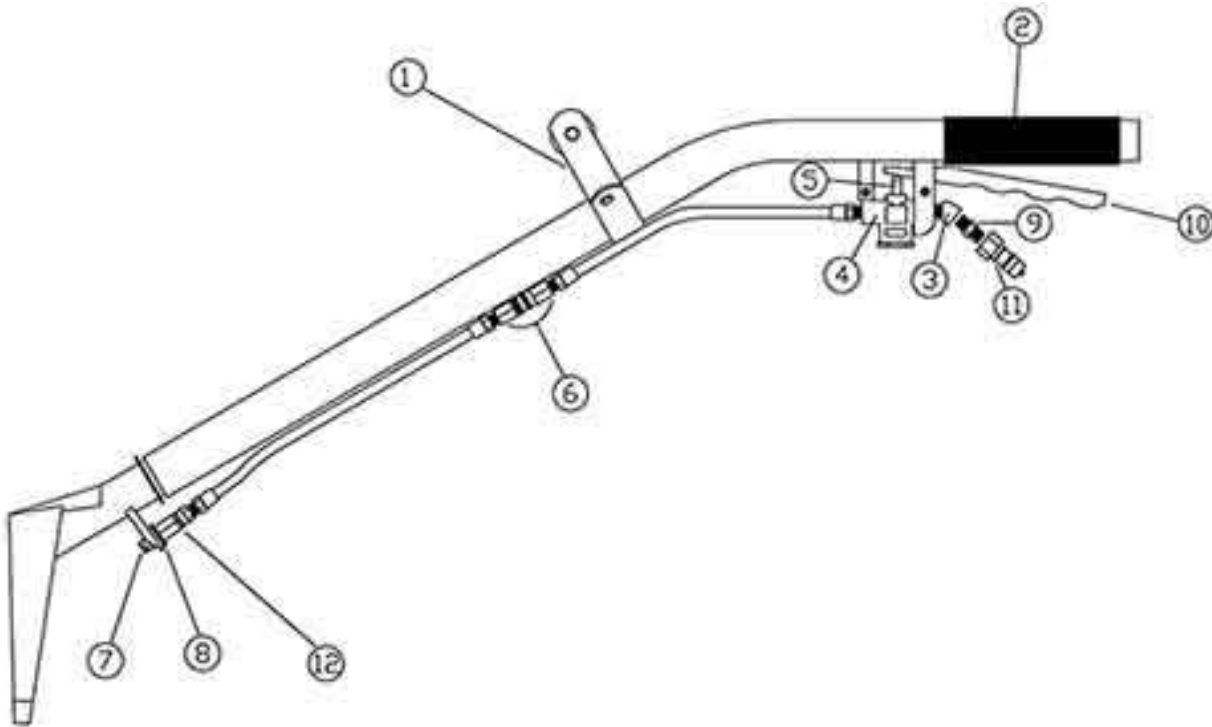

REF	PART NO.	DESCRIPTION	NOTES:
1	435-030	D Handle	
2	555-200	Vinyl Grip 1 1/2" x 6" Black	
3	555-184	Elbow 45, Street 1/4"	
4	535-110	Valve ASSY	
5	538-110	Valve Repair Kit	
6	580-117	QC 1/8 Male & Female (Close)	
7	561-075	9503 Vee Jet	
8	538-322	Spacer, Jet (538-322)	
9	555-272	Hex Nipple 1/4	
10	566-015	Handle Cast Alum	
11	580-015	Q.C 1/4 Male (close)	
12	582-079	Swivel, 1/4 FM x 1/4 FM	



**40" STAIR TOOL (255-115)**  
**SPECIAL ORDER**

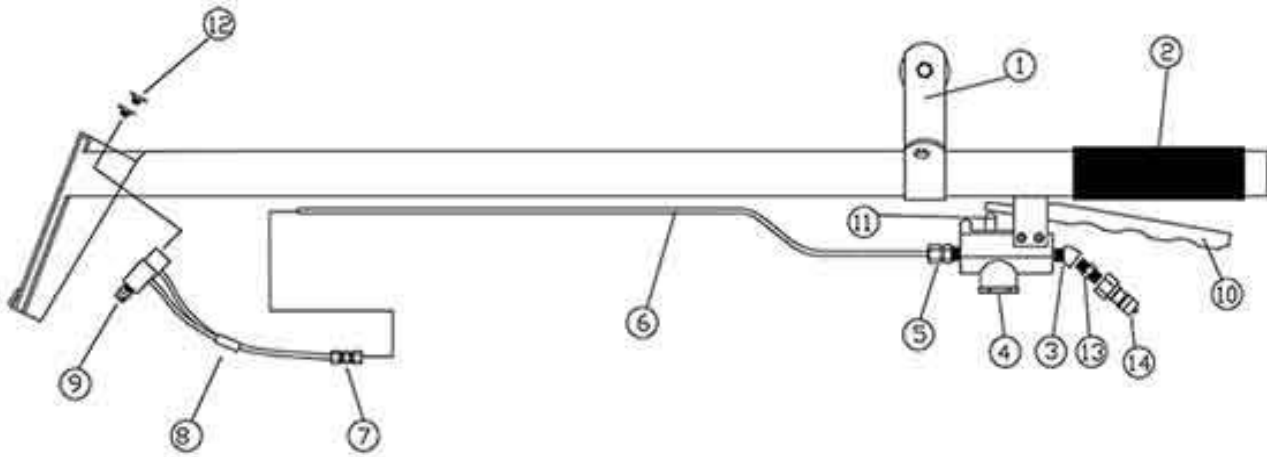

REF	PART NO.	DESCRIPTION	NOTES:
1	435-030	D Handle	
2	555-200	Vinyl Grip 1 1/2" x 6" Black	
3	555-184	Elbow 45, Street 1/4"	
4	535-115	Valve ASSY	
5	555-108	Comp Fitting 1/4 x 1/4 MPT	
6	480-200	Tubing, 1/4 O.D S.S (18")	
7	555-116	1/4 x 1/4 Comp Fitting	
8	553-105	Y Manifold	
9	561-110	Vee Jet 11003	
10	566-015	Handle Cast Alum	
11	538-110	Valve Repair Kit	
12	538-421	Machine Screw	
13	555-272	Hex Nipple 1/4	
14	580-015	Q.C 1/4 Male (close)	

# HAND TOOL (VR) NO DRIP 3" (255-070)

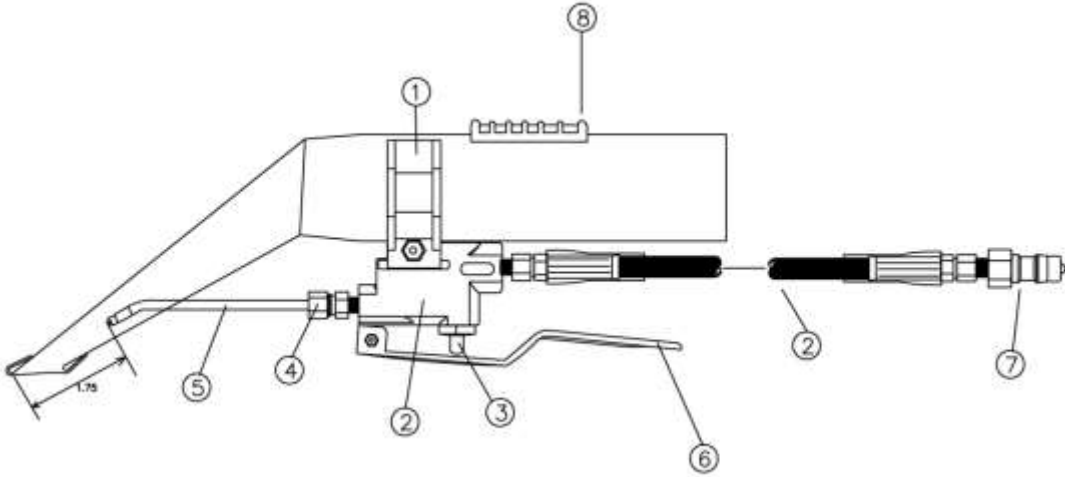

REF	PART NO.	DESCRIPTION	NOTES:
1	538-205	Valve Hanger	
2	535-105	Valve ASSY	
3	538-025	Valve Repair kit	
4	555-106	1/8" x 1/4" Comp Fitting	
5	562-100	Tee Jet 11002	
6	564-250	Jet Retainer Plate & Hardware	
7	566-020	Handle Detailer	
8	580-015	Q.C 1/4 Male (close)	

## WAND 1-3/4 S-BEND 4-JET (250-017)

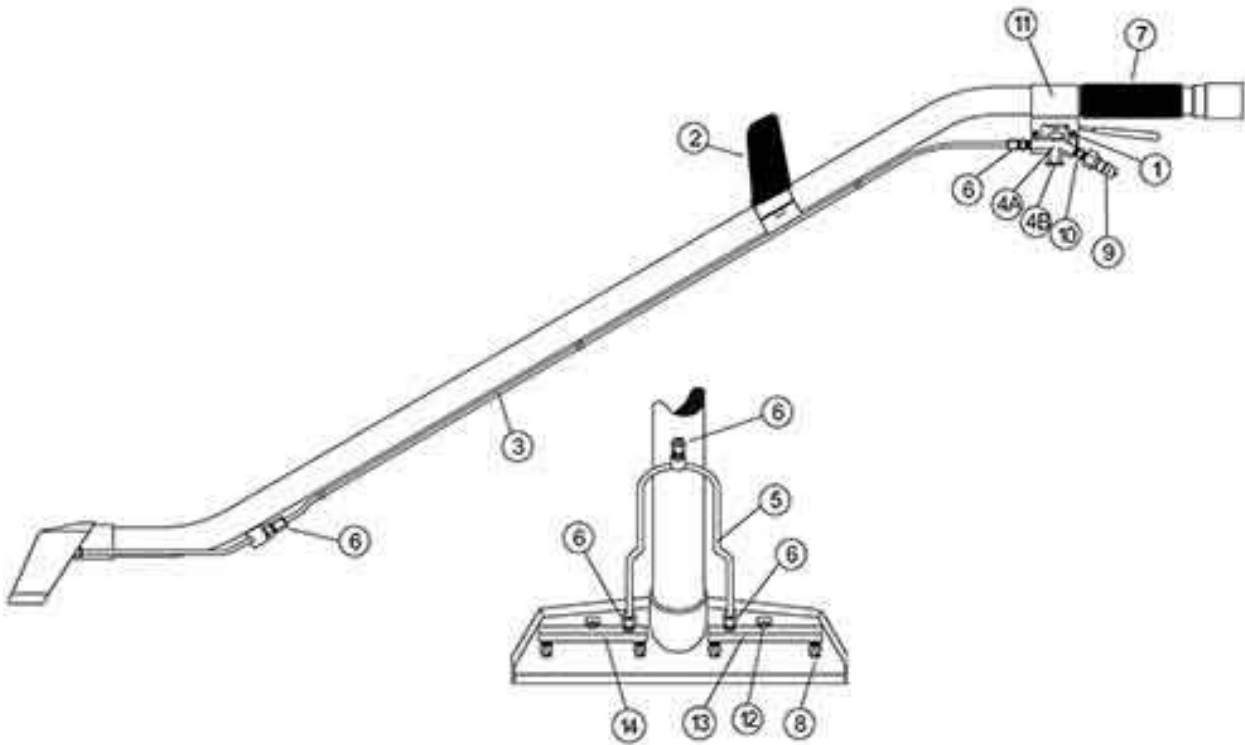

REF	PART NO.	DESCRIPTION	NOTES:
1	400-148	Locknut 4 x 40 Nylon S.S	
2	435-022	Handle, Wand 1-3/4 Tube	
3	480-200	Tubing 1/4 S.S	
4A	535-011	Valve Angle (c/w trigger)	
4B	540-015	Repair kit	
5	564-060	Manifold 2 jet S-Bend	
6	555-108	Comp Fitting 1/4 x 1/4	
7	553-201	Vinyl Grip, 1-3/4 x 6	
8	561-003	Vee Jet (9501)1/8	
9	580-015	Q.C 1/4" Male (Closed)	
10	555-572	Hex Nipple, 1/4"	
11	538-221	Valve Hanger 1-3/4, Angle Valve	
12	410-100	Screw	
13	564-065	Manifold Left	
14	564-070	Manifold Right	

## STAIR TOOL 36" S-BEND (255-116)

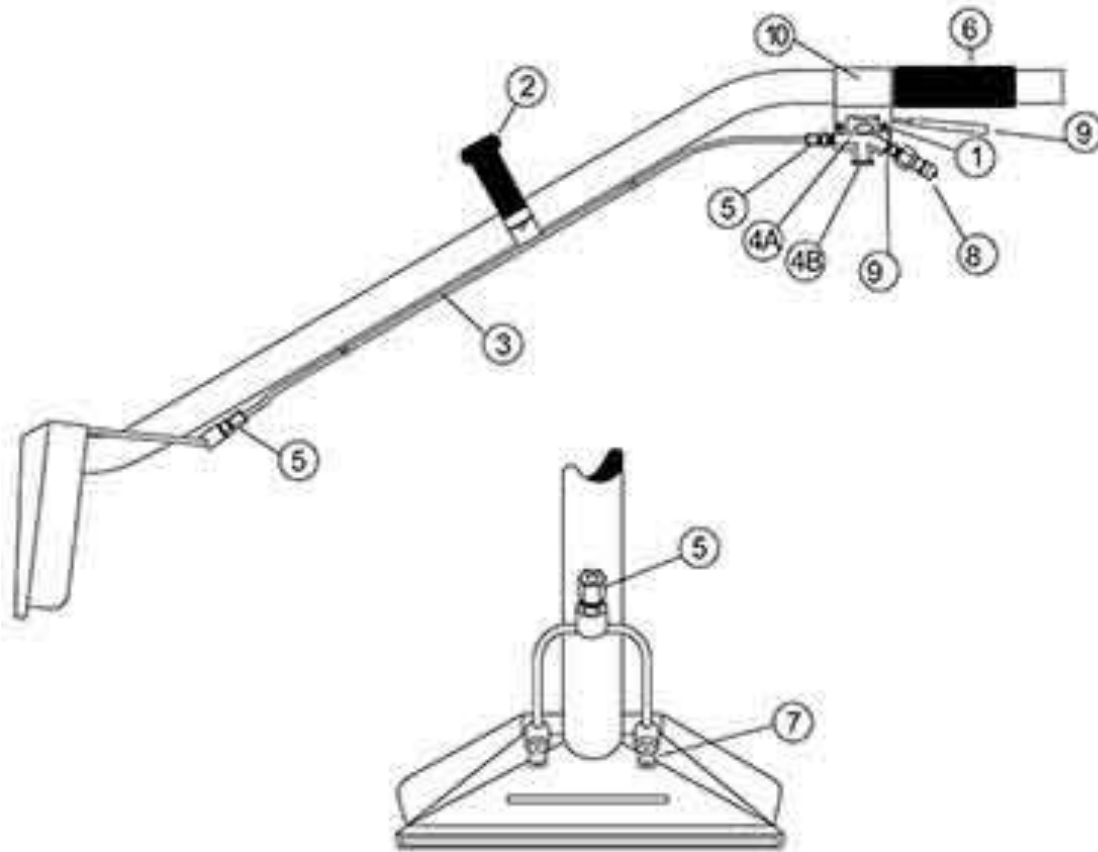

REF	PART NO.	DESCRIPTION	NOTES:
1	400-148	Locknut 4 x 40 Nylon S.S	
2	435-021	Handle, Wand 1.5 Tube	
3	480-200	Tubing 1/4 S.S	
4A	535-012	Valve Angle Brass (c/w trigger)	
4B	540-015	Repair kit	
5	555-108	Comp Fitting 1/4 x 1/4	
6	553-200	Vinyl Grip, 1-1/2 x 6	
7	561-130	Vee Jet (11001.5)1/4	
8	580-015	Q.C 1/4" Male (Closed)	
9	555-572	Hex Nipple, 1/4"	
10	538-220	Valve Hanger 1-1/2	

# CLEANCO COMPACT ELECTRIC WIRING (P. 1)

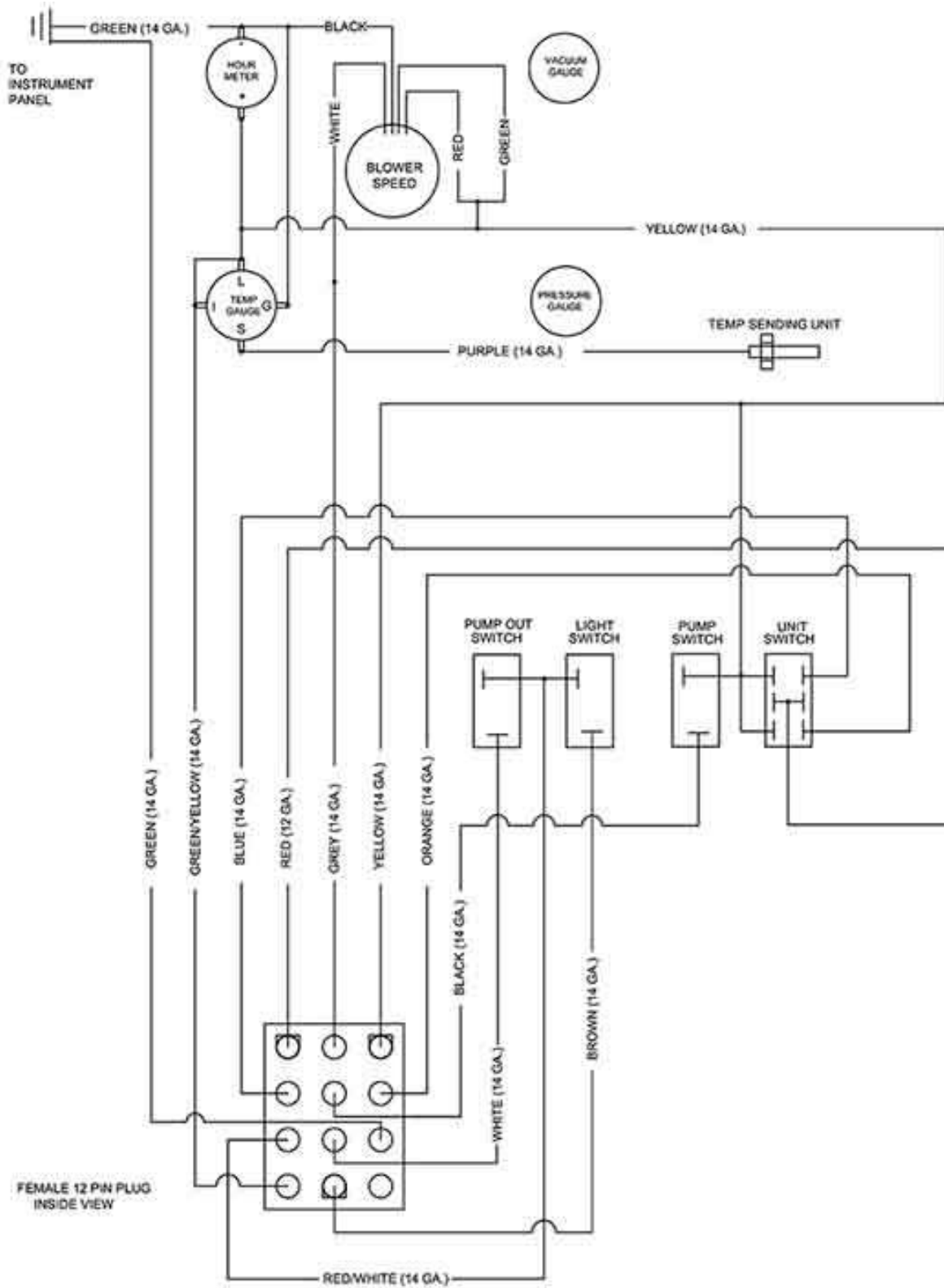

# CLEANCO COMPACT ELECTRIC WIRING (P. 2)

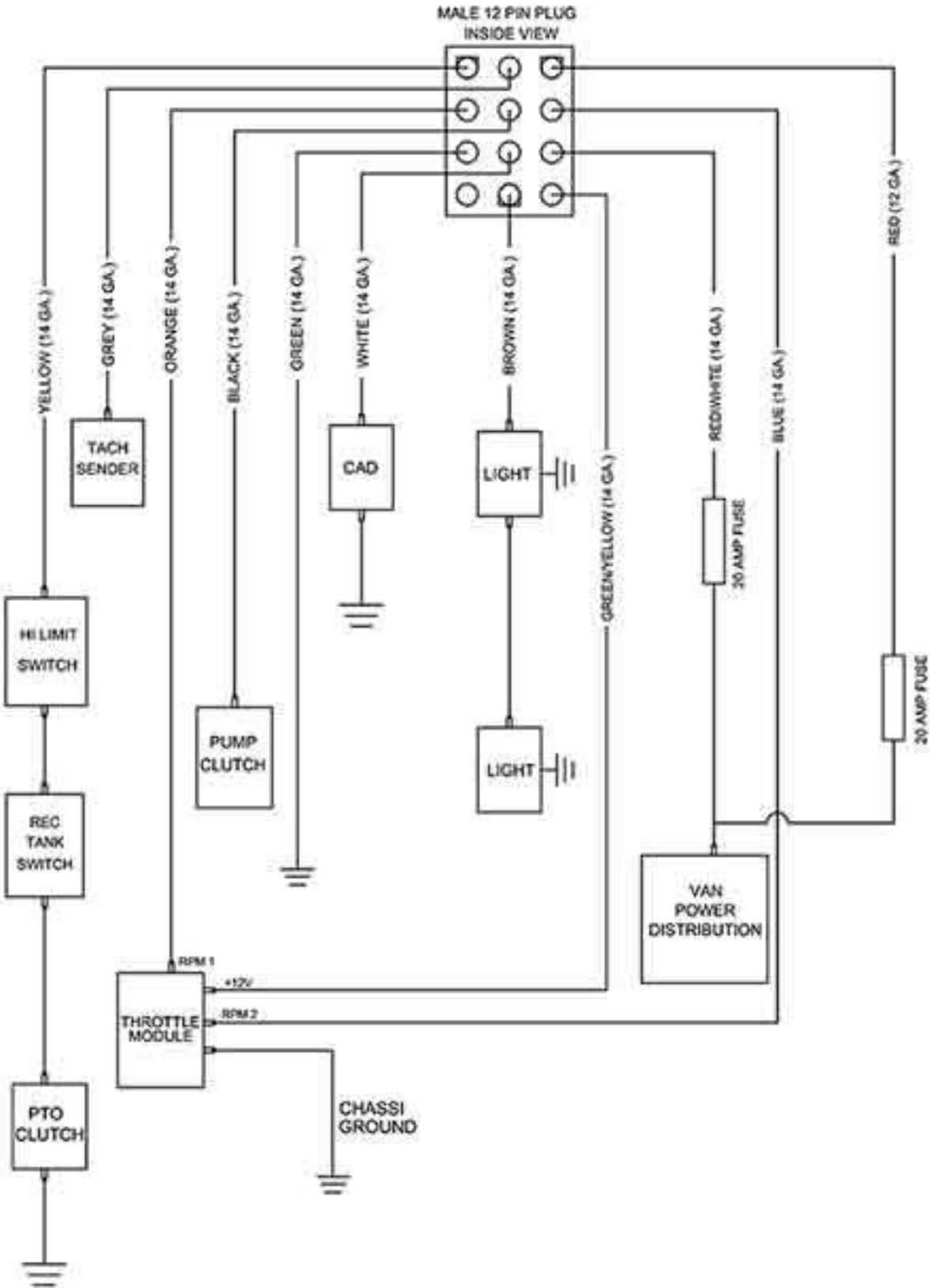

# 2014 GM & FORD

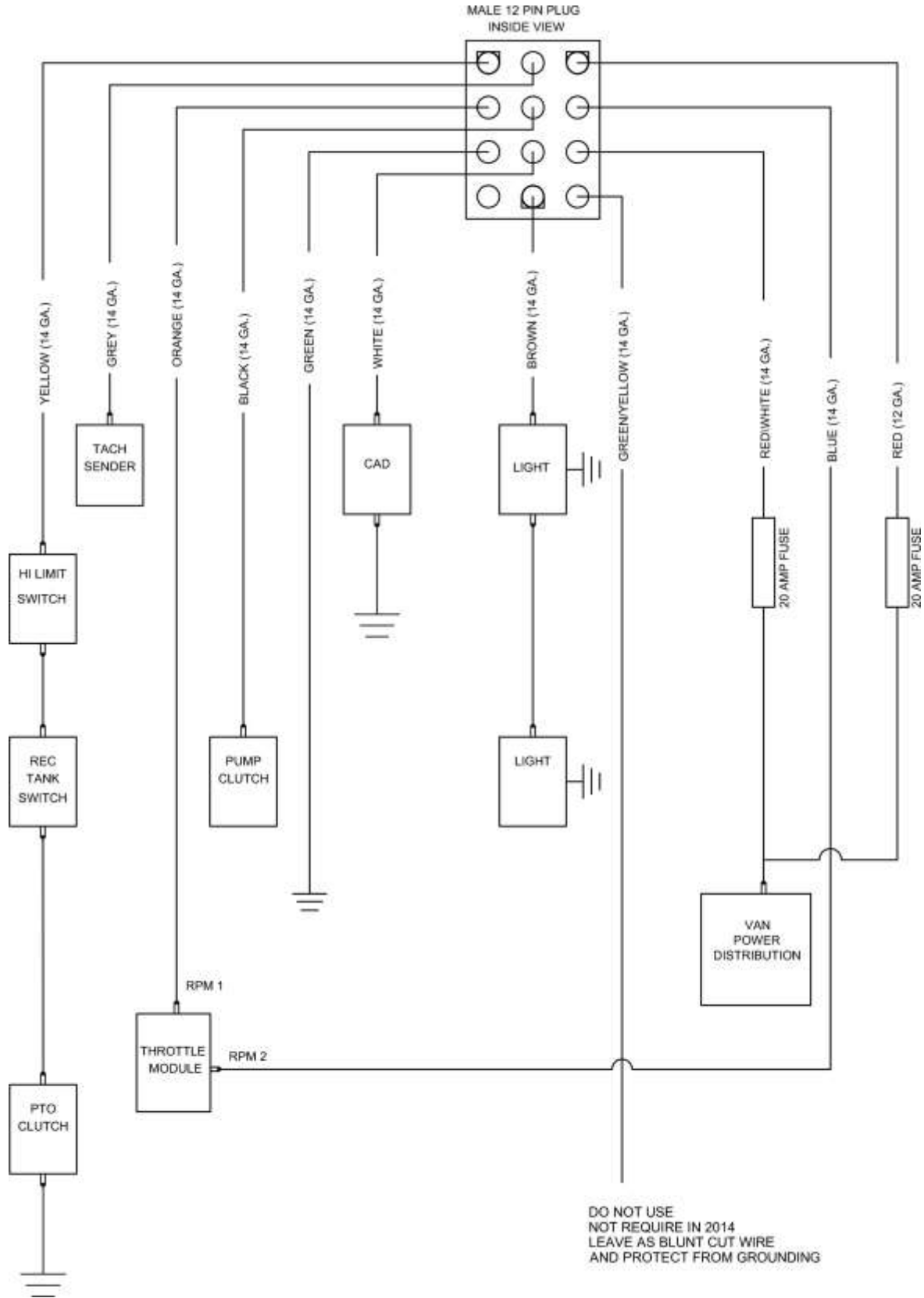



## **CLEANCO TRUCKMOUNT 5 YEAR EXTEND-A-CARE WARRANTY**



**NOTICE: REVIEW THIS WARRANTY CAREFULLY AS THIS DOCUMENT CONTAINS LIMITATIONS AND EXCLUSIONS**

### **PART I:**

Cleanco warrants each new Cleanco Compact Truckmount unit purchased from an authorized Cleanco distribution center with a Cleanco 5 Year Extend-A-Care warranty. This comprehensive warranty is divided into four distinct categories: 90 day Limited Warranty coverage, 12 month Standard Warranty coverage, 24 month Premium Warranty coverage, and 60 month Extended Warranty coverage. See below for specific warranty coverage details.

### **60 MONTH EXTENDED WARRANTY COVERAGE**

Subject to the 12 month Standard Warranty and 24 Month Premium Warranty coverage and limitations, Cleanco warrants specified systems and components of your Cleanco unit to be free from defects in material and workmanship for a period of 60 months. In the event a defect occurs in one of these specified systems or components within 60 months of receipt by the customer, Cleanco will, if satisfied on its examination that the failure is due to defective material or workmanship, repair or replace the item, in accordance with the terms stated herein.

Beginning with the 13<sup>th</sup> month and extending through the 60 months of the Extended Warranty coverage, each warranty repair or replacement is subject to a \$50.00 deductible charge.

### **60 Month Extended Warranty Components include:**

- Van Coolant Reverse Flow Heat Exchanger casing / housing, coils, and air bleeder valves
- Stainless Steel Coolant Manifolds
- Floor Wand S.S. Vacuum Head, Tubing, and D-Handle
- Holders & Shelving
- Recovery Tank body, Vacuum Relief Assembly, and Tank Lids
- Fresh Water Tank body
- Front mounting bracket
- Rear mounting bracket
- Baseplate & Baseplate brackets
- Rear Tensioner Bracket
- Silencer



"Cleanco" is a division of Esteam Manufacturing Ltd.

Page 1 of 8







## CLEANCO TRUCKMOUNT 5 YEAR EXTEND-A-CARE WARRANTY



### 24 MONTH PREMIUM WARRANTY COVERAGE

Subject to the 12 month Standard Warranty coverage and its limitations, Cleanco and component OEM's (original equipment manufacturer) warrant specified systems and components of your Cleanco unit to be free from defects in material or workmanship for a period of 24 months. In the event a defect occurs in one of these specified systems or components within 24 months of receipt by the customer, Cleanco or the OEM will, if satisfied on its examination that the failure is due to defective material or workmanship, repair or replace the item, in accordance with the terms stated herein.

#### 24 Month Premium Warranty Components include:

- |  |   |
|--|---|
| • Vacuum Blower                          | Through original equipment manufacturer |
| • High Pressure Pump                     | Through original equipment manufacturer |
| • PTO Shaft                              | Through Cleanco                         |
| • Clutches                               | Through Cleanco                         |
| • Pulleys & bushings                     | Through Cleanco                         |
| • E.T.M.<br>(Electronic Throttle Module) | Through Cleanco                         |

### 12 MONTH STANDARD WARRANTY COVERAGE

Subject to the 90 day Limited Warranty coverage and its limitations, Cleanco warrants all remaining items to be free from defects in material or workmanship for a period of 12 months from the date of receipt by the customer. In the event a defect occurs within 12 months of receipt by the customer, Cleanco will, if satisfied on its examination that the failure was due to defective material or workmanship, repair or replace the item, in accordance with the terms stated herein. (This section of warranty excludes items listed in the 90 day Limited Warranty coverage.)

### 90 DAY LIMITED WARRANTY COVERAGE

Cleanco warrants all components to be free from defects in material or workmanship for 90 days from the date of purchase. In the event a defect occurs within 90 days of receipt by the customer, Cleanco will repair or replace the item, in accordance with the terms stated herein.

#### The following items are limited to 90 day coverage:

- Rubber and synthetic rubber parts, quick disconnects, o-rings, diaphragms, valve kits, gaskets, seals, screens, gauges, electric switches and pressure switches.
- Labour costs

"Cleanco" is a division of Estearn Manufacturing Ltd.





## CLEANCO TRUCKMOUNT 5 YEAR EXTEND-A-CARE WARRANTY



### QUICK REFERRANCE WARRANTY CHART

Van Coolant Heat Exchangers	60 months	Cleanco
Recovery Tank Body	60 months	Cleanco
Fresh Water Tank Body	60 months	Cleanco
Front & Rear Mounting Brackets	60 months	Cleanco
Silencer	60 months	Cleanco
Vacuum Blower	24 months	Through - Roots
High Pressure Pump	24 months	Through - Cat Pump
PTO Shaft	24 months	Cleanco
E.T.M. (electronic throttle mod)	24 months	Cleanco
Electrical Clutches	24 months	Cleanco
P.T.I. Heat Exchanger	12 months	Cleanco
Labour	90 days	Cleanco
All Drive Belts	90 days	Cleanco
Gauges	90 days	Cleanco

#### **PART II – REPLACEMENT PARTS (UNDER WARRANTY)**

Replacement warranty parts will be genuine Cleanco parts, or parts of similar kind and quality, and may include new or Cleanco remanufactured parts at Cleanco's sole discretion.

All replacement warranty parts are warranted to be free from defects in material or workmanship from the date of the original unit purchase for the balance of the original warranty period namely 90 days, 12 months, 24 months or the remaining balance up to 60 months, whichever is applicable; all in accordance with the terms of Part I, of the warranty.

All warranty repairs must be through an authorized Cleanco distributor. Any parts installed by a non-authorized Cleanco distributor will have no warranty coverage by Cleanco.



\*Cleanco® is a division of Esteam Manufacturing Ltd.

Page 3 of 8





## CLEANCO TRUCKMOUNT 5 YEAR EXTEND-A-CARE WARRANTY



### PART III – LIMITATION ON WARRANTY COVERAGE

#### WHAT IS NOT COVERED:

- (i) No warranty is provided to any Cleanco product which has failed as a result of freezing, fire, misuse, alteration, improper amps or voltage, improper installation, accidental damage, improper maintenance, installation or repair by other than a Cleanco authorized distributor, abuse, neglect, or operation of a Cleanco product, not expressly recommended or contemplated by Cleanco; and
- (ii) No warranty is provided for mechanical or electrical breakdown caused by scale, hard water buildup, improper use of chemicals or resins, damage due to environmental conditions, and acts of God, or other events beyond the control of Cleanco; and
- (iii) No warranty is provided for mechanical or electrical breakdown or failure of a Cleanco product resulting from ordinary wear and tear, or the consequences thereof; including but not limited to the gradual reduction of the operating performance of the product. The determination of what is or is not ordinary wear and tear is at the sole discretion of Cleanco; and
- (iv) No warranty is provided for damage caused by the failure of non-warranted parts and/or accessories, even if warranted parts are damaged as a result of the failure of a non-warranted part; and
- (v) No warranty is provided for damage resulting from failure by the customer to maintain scheduled maintenance requirements. The Cleanco system has many parts which must either be replaced or checked for wear on a regular basis; including but not limited to replacement filters and lubrications. This system requires regular maintenance, service and attention by the customer; and
- (vi) No warranty is provided as to any vehicle and/or apparatus to which the Cleanco product may be mounted or attached; and
- (vii) No warranty is provided as to any extra expenses incurred by the customer, including but not limited to economic, incidental, consequential loss or damage (e.g. all labour charges beyond 90 days, fuel, towing, rental equipment, down time, lodging, commercial or business loss of any nature or kind due to product failure); whether direct or indirect, exemplary or punitive damage or loss, and whether in contract, tort or otherwise; and
- (viii) No warranty is provided as to failure of any cosmetic item or finish, labeling, silk screening, decals, paint, trim, or other similar decorative items; and
- (ix) No warranty is provided by Cleanco on aftermarket drive line (PTO) systems. This includes all aftermarket shafts, U-joints, bearings, brackets, etc. Cleanco does not warranty or guarantee performance of equipment that is installed with aftermarket drive line systems (PTO).
- (x) No warranty is provided as to any extra expenses incurred by the customer in "warranty assessments" by an OEM (original equipment manufacturer) including but not limited to economic, incidental, consequential loss or damage, fuel costs, labour charges, assessment charges, downtime, rental of equipment, lodging, commercial or business loss of any nature or kind due to product failure, whether direct or indirect, exemplary or punitive damage or loss and whether in contract, tort or otherwise; and



"Cleanco" is a division of Estearn Manufacturing Ltd.





## **CLEANCO TRUCKMOUNT 5 YEAR EXTEND-A-CARE WARRANTY**



### **PART IV – EXCLUSION OF LIABILITY**

Cleanco makes no warranties or representations, either expressed or implied, oral or written, in fact, or by operation of law, or otherwise, except as expressly stated herein as to the 90 day Limited, 12 month Standard, 24 month Premium, and 60 month Extended warranties. Cleanco, its officers, directors, agents, dealers, and its affiliates (and their respective officers, directors, agents, and dealers) shall not be liable to the customer nor to any party for liability, including without limitations, strict liability for loss, injury or damage due directly or indirectly to the use or operation of the Cleanco product; consequential, exemplary and/or punitive damage or loss, whether in contract, tort, or otherwise.

### **PART V – RETURN GUIDELINES**

Defective items must be replaced through a local Cleanco Distributor. Replacement parts will be sent via prepaid regular ground service to the distributor. The defective part must be returned prepaid to the Cleanco factory within 30 days including a letter providing the system serial number, date of purchase, material return authorization number, and customer name. If applicable, credit will be issued to the Cleanco Distributor after the item has been evaluated by Cleanco. Failure to comply with return policy will void the warranty on that item.

### **PART VI – CREDIT POLICY**

All customers purchasing parts through a Cleanco distributor must arrange credit directly with that distributor.

### **PART VII – OUTSIDE SOURCE WARRANTY REPAIRS**

At the sole discretion of Cleanco, it may be necessary to perform warranty/repair work at an outside source. A written quotation must be faxed or emailed to Cleanco for approval prior to work being performed. The written quotation that was submitted if approved will be signed and dated by Cleanco and returned by fax or email to the submitting vendor. Failure to do so will result in denial of your warranty claim.

### **PART VIII - NON-TRANSFERABILITY**

This warranty is valid to the original owner only and is not transferable.





## CLEANCO TRUCKMOUNT 5 YEAR EXTEND-A-CARE WARRANTY



### **PART IX – NOTICE – CUSTOMER OBLIGATIONS**

- (i) It is the customer's responsibility to keep copies of all receipts for service, repairs and maintenance. These records are also to include receipts for lubrication, oil and filter changes, as well as other services and repairs performed to the Cleanco system and van.
- (ii) A Maintenance Record Booklet for tracking maintenance is supplied with the purchase of every Cleanco system. (Additional Maintenance Record Booklets are available through your distributor).
- (iii) In order for you as the customer to maintain your 60 month Extended Warranty coverage, the operation, maintenance, and care of your new Cleanco equipment must adhere to the instructions and requirements listed in the enclosed Owner's Manual.
- (iv) Your responsibility as a customer includes but is not limited to cleaning, lubricating, seasonal maintenance (e.g. winterizing), replacement of worn parts and all regular scheduled or unscheduled maintenance.
- (v) Any claim for warranty must be presented through your authorized Cleanco dealer, prior to the expiration of the time limitations specified (e.g. 90 days, 12 months, 24 months, and 60 months) and not thereafter, otherwise any warranty is void.
- (vi) Failure to provide Maintenance Records upon request to Cleanco within 30 days from date requested can void the 60 month Extended Warranty.





# CLEANCO TRUCKMOUNT 5 YEAR EXTEND-A-CARE WARRANTY



## WARRANTY ENROLLMENT FORM

**TO ACTIVATE THIS WARRANTY** on your new Cleanco Truckmounted Extractor, we must receive this completed form. Upon receipt, you will be included on our Cleanco Owner's List, which entitles you to Owner's Manual updates, technical bulletins, and other important information from the factory. This warranty is subject to the terms, limitations and conditions of the Cleanco Truckmount Warranty plan in effect at the time of purchase. Please read your warranty terms in full before signing this form. By returning this form to Cleanco, you indicate acceptance of the warranty terms as specified in your warranty documentation.

I \_\_\_\_\_ have read this entire warranty and hereby understand all of the conditions, limitations and exclusions.

\_\_\_\_\_  
Company Name

\_\_\_\_\_  
Date

\_\_\_\_\_  
Distributor

\_\_\_\_\_  
Truckmount Model

\_\_\_\_\_  
Serial Number

\_\_\_\_\_  
Company Address

\_\_\_\_\_  
City

\_\_\_\_\_  
State/Prov.

\_\_\_\_\_  
Company Phone Number

\_\_\_\_\_  
Zip/Postal Code

\_\_\_\_\_  
Company Fax Number

\_\_\_\_\_  
Email

Van Year \_\_\_\_\_

Make \_\_\_\_\_

Model \_\_\_\_\_

At the sole discretion of Cleanco, it may be necessary to perform warranty/repair work at an outside source. A written quotation must be faxed or emailed to Cleanco for approval prior to work being performed. The written quotation that was submitted if approved will be signed and dated by Cleanco and returned by fax or email to the submitting vendor. Failure to do so will result in denial of your warranty claim.

\_\_\_\_\_  
Signature

\_\_\_\_\_  
Title

Please complete and fax to Cleanco at 403-291-0546 within 30 (thirty) days of purchase to validate.



3750-19th Street N.E. CALGARY, ALBERTA, CANADA T2E 6V2

"Cleanco" is a division of Estearn Manufacturing Ltd.





# CLEANCO TRUCKMOUNT 5 YEAR EXTEND-A-CARE WARRANTY



## CLEANCO TRUCKMOUNT WARRANTY INFORMATION

Components of your Cleanco Truckmount can fail due to neglect or abuse. The following information lists causes of component failure that will or could void warranty coverage.

### Blower:

- Failure to lubricate impellers daily with spray lubricants.
- Failure to maintain proper oil level in the blower.
- Failure to change oil in blower at recommended intervals.
- Failure to use the proper grade and viscosity of oil as recommended by the Manufacturer.
- Failure to maintain blower safeguard systems such as:
  - Cleaning out recovery tank lint basket after each job.
  - Cleaning off cylindrical S.S. recovery tank filter screen daily.
  - Maintaining vacuum safety relief valve.
  - Maintaining recovery tank high water shut off switch.
- Allowing foam to pass through blower.
- Failure to maintain recommended unit fast idle RPM

### High Pressure Water Pump:

- Alteration of factory water system plumbing.
- Failure to maintain proper oil level in the pump.
- Failure to change oil in pump at recommended intervals.
- Failure to use the proper grade and viscosity of oil as recommended by the Manufacturer.
- Failure to protect pump against freezing.
- Failure to maintain electric clutch pump protection shut off system.
- Failure to clean and maintain pump filter screen.
- Use of improper chemicals.

### Recovery Tank:

- Failure to clean out recovery tank lint basket after each job.
- Failure to clean recovery tank cylindrical S.S. filter screen(s) daily.
- Failure to maintain vacuum safety relief valve.
- Failure to maintain recovery tank high water shut off switch.
- Failure to clean out recovery tank at recommended intervals.
- Improper use of chemicals.
- Failure to protect against freezing.

### All Water Handling Systems: (Wand, Hoses, Heat Exchangers, Pump, Tanks, Flow Meter, etc.)

- Failure to protect against freezing.

### Electrical Clutch & PTO Shaft:

- Failure to clean out all recovery tank filters daily.
- Failure to maintain vacuum safety relief valve on recovery tank.
- Failure to maintain recommended unit fast idle RPM
- Failure to maintain adequate grease levels in PTO shaft & bearings.
- Greasing required every 250 hours of operation.

