



MHS
BOILERS

SupeRAC-AR Installation, Operating and Service Manual

High Performance Reversed Flame, 3 Pass High
Efficiency Steel Shell & Tube Type Hot Water
Boiler



MHS Boilers Ltd
3 Juniper West
Fenton Way
Basildon Essex
SS15 6SJ

Main Tel: 01268 546700
Spares Tel: 01268 546771
Service Tel: 01268 546770
Technical Help: 01268 545772
Fax: 01268 888270
WWW.MHSBOILERS.COM

CONTENTS

<u>General description</u>	page 3
<u>Technical data</u>	page 4
General regulation	page 5
<u>Clearances</u>	page 7
<u>Dimensions</u>	page 8
<u>Handling</u>	page 9
Installation	page 9
<u>Location</u>	page 9
<u>Combustion chamber door opening and adjustment</u>	page 9
<u>Burner mounting</u>	page 10
<u>Prevention of condensation</u>	page 10
<u>Fuel supply</u>	page 11
<u>Fitting the case (models 80AR – 900)</u>	page 11
<u>Mounting the control panel (models 1220 – 3600)</u>	page 12
<u>Flue system</u>	page 12
<u>System water</u>	page 13
<u>Control panel schematic</u>	page 14
<u>Preliminary Checks</u>	page 15
<u>First start up</u>	page 15
<u>User instructions</u>	page 16
<u>Operation / Controls</u>	page 16
Notes	page 18

General Description

The SupeRAC-AR series of boilers are reversed flame three pass forced draught combustion type, carbon steel shell and tube appliances. Suitable for use with appropriate power flame burners with Natural Gas, LPG, Light or Heavy Fuel Oil or Biodiesel.

23 models in the range with outputs from 81kW to 3610kW with efficiencies > 94%.

Working pressure 6bar (or upon request / to special order, either 8bar or 10bar)



SupeRAC-AR Models 80AR -900AR



SupeRAC-AR Models 1100AR -3600AR

Technical data

SuperRAC AR Models 80 - 900

Model SuperRAC AR		80	90	130	170	200	250	300	350	400	450	500	600	700	800	900	
Nominal output	kW	81	91	132	170	203	253	304	354	398	455	505	610	715	820	920	
Input (net)	kW	86.2	96.7	140	179.6	214	266	320	372	418	477	530	640	750	860	966	
Fuel consumption Nat Gas (G20)	m ³ /h	8.97	10.07	14.58	18.7	22.29	27.71	33.33	38.75	43.54	49.69	55.21	66.67	78.13	89.59	100.63	
Fuel consumption 35 sec Oil	kg/h	7.26	8.14	11.79	15.13	18.03	22.41	26.96	31.34	35.22	40.19	44.66	53.93	63.2	72.47	81.4	
Combustion chamber resistance	mbar	0.4	0.5	0.9	0.9	1.2	1.8	2.5	3.3	2.7	3.2	3.7	3.6	4.5	4.4	4.8	
Max flow temperature	°C	90															
Min return temperature	°C	60															
Design flow rate Δt 10K	l/s	1.92	2.16	3.14	4.04	4.83	6.02	7.23	8.42	9.47	10.83	12.02	14.52	17.02	19.52	21.9	
Design flow rate Δt 15K	l/s	1.28	1.44	2.09	2.69	3.22	4.01	4.82	5.61	6.31	7.22	8.01	9.68	11.34	13.01	14.6	
Design flow rate Δt 20K	l/s	0.96	1.08	1.57	2.02	2.41	3.01	3.61	4.21	4.73	5.41	6.01	7.26	8.51	9.76	10.95	
Hydraulic resistance Δt 10K	kPa	1.01	1.26	2.65	1.55	2.25	3.66	5.16	6.95	4.04	4.94	6.29	4.04	5.61	7.4	8.98	
Hydraulic resistance Δt 15K	kPa	0.45	0.56	1.18	0.69	1	1.63	2.3	3.1	1.8	2.2	2.8	1.8	2.5	3.3	4	
Hydraulic resistance Δt 20K	kPa	0.25	0.32	0.66	0.39	0.56	0.92	1.29	1.74	1.01	1.24	1.58	1.01	1.4	1.85	2.24	
Nominal flue gas mass Nat Gas	kg/h	139	156	226	289	345	429	516	599	674	769	854	1031	1208	1386	1557	
Nominal flue gas mass Oil	kg/h	132	148	215	275	328	408	491	571	641	732	813	982	1150	1319	1482	
Nominal flue gas temp Nat Gas	°C	105															
Nominal flue gas temp Oil	°C	135															
Nom Min Flue Draught	Pa	10															
Water content	litres	119	119	155	228	228	285	276	329	402	402	476	697	795	733	817	
Weight (empty)	kg	250	270	310	460	480	540	550	610	870	890	940	1310	1380	1440	1620	
Weight (full)	kg	369	389	465	688	708	825	826	939	1272	1292	1416	2007	2175	2173	2437	
Shunt recirculation flow rate	l/s	25-30% of Design Flow Rate															
Max working pressure	bar	5 (8 upon request)					6 (8 or 10 upon request)										

SuperRAC AR Models 1100 - 3600

Model SuperRAC AR		1100	1300	1640	1850	2050	2580	3100	3600
Nominal output	kW	1100	1300	1645	1850	2050	2580	3100	3610
Input (net)	kW	1155	1365	1727	1942	2153	2709	3255	3791
Fuel consumption Nat Gas (G20)	m ³ /h	120.18	142.04	179.71	202.08	224.04	281.89	338.71	394.49
Fuel consumption 35 sec Oil	kg/h	97.27	114.96	145.45	163.56	181.33	228.15	274.14	319.28
Combustion chamber resistance	mbar	5.4	5.6	5.8	6	6.5	6.8	7.5	8.4
Max flow temperature	°C	90							
Min return temperature	°C	60							
Design flow rate Δt 10K	l/s	26.19	30.95	39.16	44.04	48.8	61.42	73.8	85.95
Design flow rate Δt 15K	l/s	17.46	20.63	26.11	29.36	32.53	40.95	49.2	57.3
Design flow rate Δt 20K	l/s	13.09	15.47	19.58	23.11	25.63	30.71	36.9	42.97
Hydraulic resistance Δt 10K	kPa	8.1	12.2	10.1	13.1	15.7	14.3	20.2	26.9
Hydraulic resistance Δt 15K	kPa	3.6	5.4	4.5	5.8	7	6.4	9	12
Hydraulic resistance Δt 20K	kPa	2.02	3.05	2.5	3.2	3.9	3.5	5.05	6.7
Nominal flue gas mass Nat Gas	kg/h	1862	2201	2785	3131	3471	4368	5248	6113
Nominal flue gas mass Oil	kg/h	1769	2090	2645	2974	3297	4148	4984	5805
Nominal flue gas temp Nat Gas	°C	105							
Nominal flue gas temp Oil	°C	135							
Nom Min Flue Draught	Pa	10							
Water content	litres	1277	1372	2010	2125	2163	3155	3292	4839
Weight (empty)	kg	2200	2580	3300	3640	3710	5280	5760	7490
Weight (full)	kg	3477	3952	5310	5765	5873	8435	9052	12329
Shunt recirculation flow rate	l/s	25-30% of Design Flow Rate							
Max working pressure	bar	6 (8 or 10 upon request)							

General regulations

This documentation contains important information, which is a base for safe and reliable installation, commissioning and operation of the SuperRac AR. Boiler. All activities described in this document may only be executed by authorized companies.

Changes to this document may be effected without prior notice. We accept no obligation to adapt previously delivered products to incorporate such changes.

Only original spare parts may be used when replacing components on the boiler, otherwise warranty will be void.

Application

The SuperRac AR Boiler may be used for heating and hot water production purposes only. The boiler should be connected to closed systems with a maximum temperature of 100°C (high limit temperature); maximum set point temperature is 90°C.

Norms and regulations

When installing and operating the boiler, all applicable norms (European and local) should be fulfilled:

- Local Building regulations for installing combustion air and flue gas systems;
 - Regulation for connecting the boiler to the electrical appliance;
 - Regulations for connecting the boiler to the local gas network;
 - Norms and regulations according to safety equipment for heating systems;
 - Any additional local laws/regulations with regard to installing and operating heating systems.
-
- 92 / 42 / EEC Boiler efficiency directive – 90 / 396 / EEC Gas appliance directive – 73 / 23/ EEC Low voltage directive – 89 / 336 / EEC EMC directive
 - EN 656 Gas-fired central heating boilers – Type B boilers of nominal heat input exceeding 70 kW but not exceeding 300 kW
 - EN 15420 Gas-fired central heating boilers - Type C boilers of nominal heat input exceeding 70 kW, but not exceeding 1000 kW
 - EN 15417 Gas-fired central heating boilers - Specific requirements for condensing boilers with a nominal heat input greater than 70 kW but not exceeding 1000 kW
 - EN 13836 Gas fired central heating boilers - Type B boilers of nominal heat input exceeding 300 kW, but not exceeding 1000 kW
 - EN 15502-1 Gas-fired central heating boilers - Part 1: General requirements and tests
 - EN 55014-1 Electromagnetic compatibility - Requirements for household appliances, electric tools and similar apparatus Part 1: Emission
 - EN 55014-2 Electromagnetic compatibility - Requirements for household appliances, electric tools and similar apparatus Part 2: Immunity - Product family standard
 - EN 61000-3-2 Electromagnetic compatibility (EMC) - Part 3-2: Limits - Limits for harmonic current emissions (equipment input current 16 A per phase)
 - EN 61000-3-3 Electromagnetic compatibility (EMC) - Part 3-3: Limitation of voltage changes, voltage fluctuations and flicker in public low-voltage supply systems, for equipment with rated current 16 A per phase and not subject to conditional connection
 - EN 60335-1 Household and similar electrical appliances -Safety - Part 1: General requirements
 - EN 50165 Household and similar electrical appliances -Safety - Part 2-102: Particular requirements for gas, oil and solid-fuel burning appliances having electrical connections

The following Codes of Practice are also applicable: -

BS 6644 : 2011 Specification for gas fired hot water boilers of rated inputs between 70kW (net) and 1.8MW (net) (2nd and 3rd family gases).

BS 6880:1988 Code of Practice for low temperature hot water heating systems of output greater than 45kW. Parts 1, 2 & 3.

BS 6891:2005 + A2:2008 Specification for installation of low-pressure gas pipework of up to 35mm (R11/4) in domestic premises (2nd family gases).

BS 7593:2006 Code of Practice for treatment of water in domestic hot water central heating systems.

BS 7671:2008 Requirements for electrical installations. IEE Wiring Regulations. Seventeenth Edition

BS EN 12828 2003 Heating systems in buildings – Design for water based heating systems.

CISBE Guide reference sections B7, B11 and B13.

CP342 Part 2: 1974 Code of Practice for centralized hot water supply.

IGE/UP/1 or 1A Gas Tightness Testing & Purging of Commercial Industrial Gas Installations

IGE/UP/2 Gas installation pipework, boosters and compressors on Industrial and Commercial premises.

IGE/UP/4 Commissioning of gas fired plant on industrial and commercial premises.

IG/UP/10 edition 3 Installation of gas appliances in Industrial and Commercial premises.

Part 1: Flued appliances.

Through their unique construction, the SupeRac Boiler range of central heating units are renowned for their:

- High thermal output
- Durability
- Can be supplied in a wide range of models

Through active and market oriented research, MHS Boilers Ltd is in a position to offer solutions for the most challenging heating requirements.

The supplier

MHS Boilers Ltd are proud to supply and technically support the SupeRac AR Boiler Range of boilers throughout the United Kingdom. For advice or more information please contact your local sales representative or our head office via 01268 546700. or via our website www.mhsboilers.com

This document

The present documentation has been prepared with the following target groups in mind:

- The technical consultant
- The installer
- The maintenance technician
- The user

MHS Boilers Ltd has opted to make the technical documentation as comprehensive as possible in the form of this book, in order to ensure that these target groups have all the information they need. As the supplier we would be happy to help you in connection with any additional information that you may require. This document covers the following aspects relating to the boilers:

- General description
- Technical specifications
- Requirements for design and installation
- Maintenance instructions

The operating instructions for the user have been affixed to the appliance itself.

Service

For commissioning and assistance in maintenance matters, please contact the Services Department via 01268 546770.

General restrictions

MHS Boilers Ltd products should always be used, installed and maintained in accordance with the statutory requirements, specifications and standards applicable to these installations. All the data, information and suggestions concerning its products provided by MHS Boilers Ltd are based on careful study. However, the use, installation and operation of the same are outside the control of MHS Boilers Ltd and neither MHS Boilers Ltd nor any other organisations associated with it, accept any liability for the same.

Clearances.

Sufficient space must be allowed as necessary at the rear of the boiler for connection of the flue components and access to the flue collector hood clean-out port.

A minimum of 450mm must be allowed at either side of the boiler/s with attention being paid to the space required to fully open the combustion chamber door with the burner mounted upon it

Clearance at the front of the boiler must allow for cleaning of the flue tubes which run horizontally for the entire length of the boiler minus the thickness of the combustion chamber door and the depth of the flue collector hood. The clearance required at the front, measured from the front of the boiler body (excluding the door) must not be less than dimension B1 in the following tables.

Dimensions SuperRAC AR

Models 80 - 3600

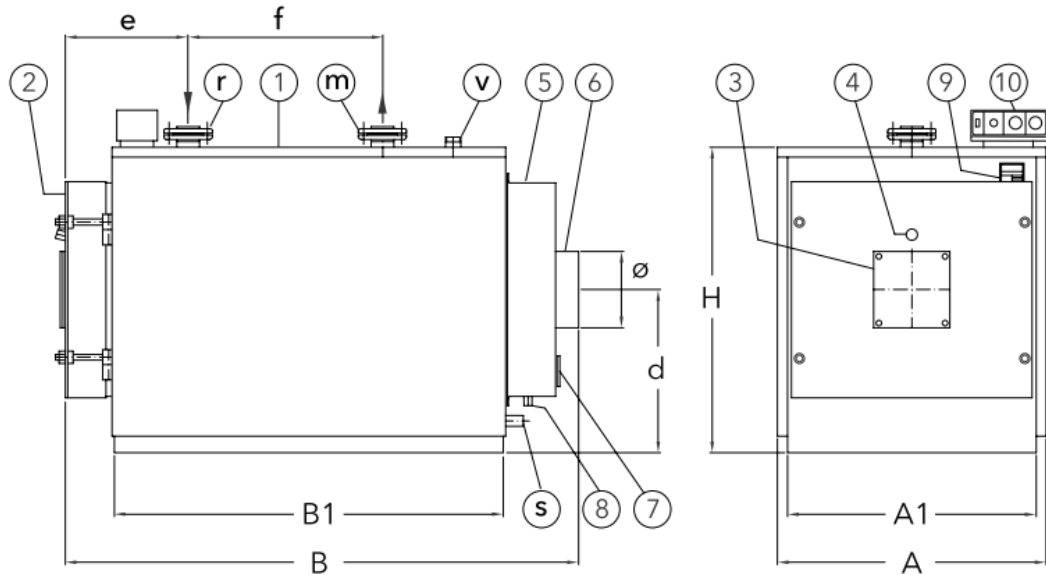

- | | | | |
|----------------------------|------------------------------------|--------------------|------------------------|
| 1. Boiler shell | 4. Combustion chamber viewing port | 7. Cleaning access | m Flow connection |
| 2. Combustion chamber door | 5. Flue collector | 8. Condense drain | r Return connection |
| 3. Burner mounting plate | 6. Flue connection | 9. Data badge | v Safety valve tapping |
| | | 10. Control panel | s Drain |

Model SuperRAC AR		80	90	130	170	200	250	300	350	400	450	500	600	700	800	900
Dimensions	A mm	790	790	790	940	940	940	940	940	1040	1040	1040	1240	1240	1240	1240
	B mm	1110	1110	1360	1405	1405	1655	1655	1905	1990	1990	2290	2345	2545	2545	2795
	H mm	880	880	880	990	990	990	990	990	1150	1150	1150	1280	1280	1280	1280
	A1 mm	750	750	750	900	900	900	900	900	1000	1000	1000	1200	1200	1200	1200
	B1 mm	760	760	1010	1010	1010	1260	1260	1510	1512	1512	1812	1814	2014	2014	2264
	d mm	460	460	460	510	510	510	510	510	595	595	595	640	640	640	640
	e mm	430	430	430	465	465	465	465	465	625	625	625	625	625	625	625
	f mm	260	260	510	450	450	700	700	950	792	792	1092	974	1174	1174	1424
Connections	r/m DN	2"	2"	2"	65	65	65	65	65	80	80	80	100	100	100	100
	v DN	1½"	1½"	1½"	1½"	1½"	1½"	1½"	1½"	2"	2"	2"	65	65	65	65
	s DN	¾"	¾"	¾"	¾"	¾"	¾"	¾"	¾"	¾"	¾"	¾"	¾"	¾"	¾"	¾"
	Ø mm	200	200	200	220	220	220	220	220	250	250	250	350	350	350	350

Model SuperRAC AR		1100	1300	1640	1850	2050	2580	3100	3600
Dimensions	A mm	1380	1380	1610	1610	1610	1800	1800	2000
	B mm	2950	3200	3245	3385	3535	3955	4255	4790
	H mm	1500	1500	1800	1800	1800	2000	2000	2210
	A1 mm	1380	1380	1610	1610	1610	1800	1800	2000
	B1 mm	2416	2666	2680	2820	2970	3320	3620	4024
	d mm	810	810	965	965	965	1070	1070	1700
	e mm	430	430	430	430	430	510	510	522
	f mm	1700	1950	1440	1580	1730	1700	2000	2200
Connections	r/m DN	125	125	150	150	150	200	200	200
	v DN	80	80	100	100	100	125	125	125
	s DN	1½"	1½"	1½"	1½"	1½"	1½"	1½"	1½"
	Ø mm	400	400	450	450	450	500	500	600

Handling / Scope of Supply

Models up to and including 900AR are supplied with the control panel, insulating blankets, ceramic fibre packing material (for sealing around the burner blast tube) and documentation packed inside the combustion chamber. The casing and burner assembly are supplied in separate cartons.

Models 1100AR to 3600AR are factory pre-insulated and have their casing panels fitted; the control panel, documentation and ceramic fibre packing material (for sealing around the burner blast tube) is packed inside the combustion chamber

The boilers are equipped with lifting eyes to assist with the moving and handling of the boiler body

Installation

Location

The location chosen for the installation of the boiler/s must be flat and level to facilitate correct alignment of connections and must be capable of supporting the units when full of water.

The floor or plinth must be fireproof in accordance with BS 6644.

The plant room must have sufficient space for the installation of the boilers, associated pipework, pumps, controls, flues, ventilation and with due allowance to access and servicing of other pieces of equipment.

Adequate space must be provided around the boiler to allow the removal of the burner and opening of the combustion chamber door and removing the flue baffles.

Combustion chamber door opening and adjustment

The door can be opened from both sides (except for models 2580AR – 3600AR).

The doors are normally supplied opening from left to right.

To open the door, remove the fixing nuts from the left hand side.

To reverse the direction of opening of the combustion chamber door it will be necessary due to the size and weight of door to utilise lifting gear.

- Attach lifting gear via the two holes in the upper part of the door assembly.
- Remove the 4 door retaining nuts
- Carefully remove the door assembly and set to one side
- Remove the jam nuts from the tie rods on the left hand side and transfer them to the rods at the right hand side (positioning them approximately the same as when on the left hand ties rods).
- Carefully offer up the door assembly and remount onto the tie rods and retain using previously removed nuts. Release and remove any lifting aids/equipment.

To adjust and tighten the door:

- Slightly slacken back the jam nuts.
- Tighten the door evenly onto the front of the boiler body using the door retaining nuts/capstans to form a gas tight seal.
- Re-tighten as necessary the jam nuts back against the bush seating on the door assembly.
- Proceed to mount the burner, following which, check and adjust as necessary, the fitting of the combustion chamber door against the boiler body

Burner mounting

Follow carefully the instructions supplied with burner.

The burner mounting plate must be cut and drilled as appropriate to the dimensions of the burner to be utilised. It is extremely important that any space around the burner blast tube is packed with the ceramic fibre material supplied with the boiler.

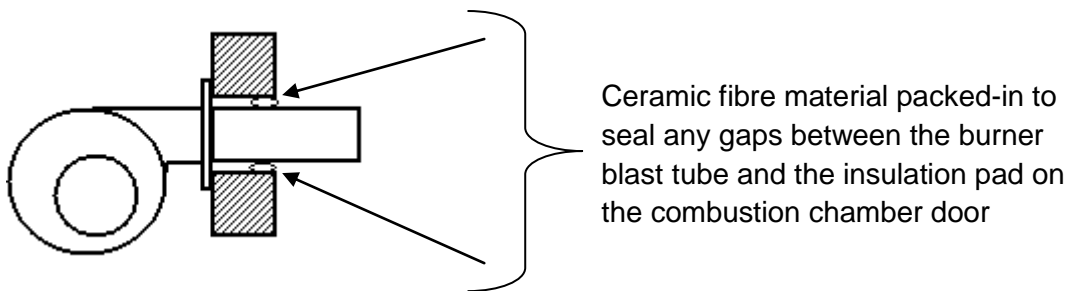

Prevention of Condensation

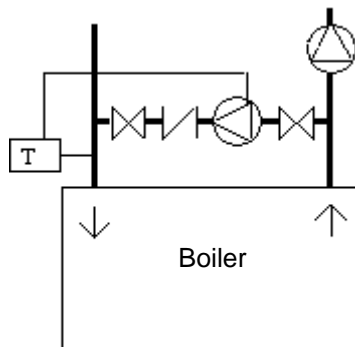

It is most important to ensure that the return water temperature entering the boiler is maintained above the dew point temperature of the flue gases. An acceptable method of creating of this facility is to install a link pipe between the main flow and return pipes serving the boiler, with a pump and a non-return valve included (as shown above). The pump needs only to be of a very low head and the flow rate should be in the order of 25-30% of the mass flow of the main boiler pump. The anti-condensation pump should be controlled by a thermostat mounted onto the return pipe adjacent to the return pipe connection of the boiler and the temperature setting should be nominally 60°C for gas firing and 50°C for oil firing.

Fuel supply

Gas supply pipework must be in accordance with BS 6891 or IGE/UP/2

The gas installation must be soundness tested to and purged in accordance with BS 6891 or IGE/UP/1 & IGE/UP/1A.

Gas connections to the burner shall not be smaller than the connection size on the burner. If a gas pressure booster is required (refer to the manual supplied with the burner), then the controls must include a low gas pressure cut off device at the inlet to the booster. It may be necessary to install a governor between the booster and the burner gas train should the inlet pressure to the gas train exceed 50mbar.

The oil storage and supply system should be designed and installed in accordance with BS.5410 Part 2. If liquid bio fuel is being used, ensure all components are suitable for such use. Liquid bio fuel must be in accordance with BS EN 1423.

The oil supply pipe between storage tank and burner should be installed using copper, steel or aluminium pipe and fittings. Galvanised pipes are not considered suitable

The oil supply pipe should terminate adjacent to the burner with an isolating valve and should include metal bowl type filter.

Fitting the case (Models 80AR – 900AR)

See Fig.1

It is advised to complete the installation of the boiler before fitting the casing and control panel assembly.

Wrap the insulating blanket (1) around the drum of the boiler body (making cuts/apertures for the flow and return pipes as necessary). Retain the insulation in place using the securing bands.

Next, fit the left hand side casing panel (3) by locating the lower retaining bracket of the panel inside the lower lateral rail of the boiler body assembly, and then hook the top part of the panel on to the upper structural rail of the boiler body.

Repeat for the right hand side panel (2).

Temporarily position the top cover panels (4) & (5) on to the top of the boiler; unpack the control panel (6) and carefully extend the capillary tubes of the thermostats etc and pass them through the hole in the top cover panel (4). Insert the sensing bulbs of the instrument capillaries into the thermostat pockets adjacent to the flow pipe tube on the top of the boiler. Secure the control panel to the top cover panel (4), and then finally locate the top casing panels.

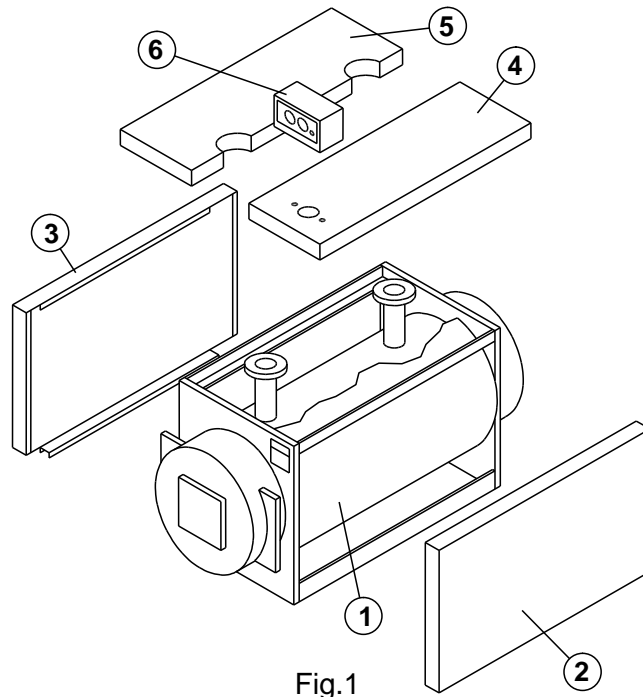

Fig.1

Mounting the control panel. (Models 1220 - 4070)

Mount the control panel using the supplied bracket on to the casing at a suitable and convenient location on the top or side of the boiler casing panels.

The instrument capillaries must be carefully extended and located into the thermostat pockets adjacent to the flow pipe assembly on the boiler body.

Flue system

SuperRAC Boilers are suitable for open flue type installations B23 taking air for combustion from the room in which it is installed; the boiler plant room must be suitably ventilated to BS6644.

The flue pipe and components serving the SuperRAC boiler must be suitable for working temperatures of not less than 250°C and should be thermally insulated.

The route of the flue should be as short as possible and sized appropriately to ensure complete evacuation of combustion gases without causing excessive back pressure.

The flue should generate sufficient draught to overcome its own resistance with a minimum negative draught at the boiler flue connection in the order of 10 – 30Pa.

If the draught generated in the flue is likely to exceed 30Pa, then a suitable draught stabiliser should be installed locally to the flue connection at the boiler.

The flue installation should comply with the requirements of the Clean Air Act 1956, BS 6644, BS5440 and IGE/UP/10 as applicable.

System water

Care must be taken to ensure that system pipe work is cleansed and flushed prior to filling the boiler.

The system water must be treated with a good quality corrosion inhibitor and the water condition must be maintained to ensure that the following values are observed:

pH 8.3 – 9.5

Hardness <100mg CaCO₃/litre

Chlorides <50mg/litre

Oxygen <0.1mg/litre

Phosphates <30/mg/litre

It is strongly recommended to install coarse strainers to protect the boiler, pumps, valves etc from the effects of solid debris or particles within the system.

Control panel schematic

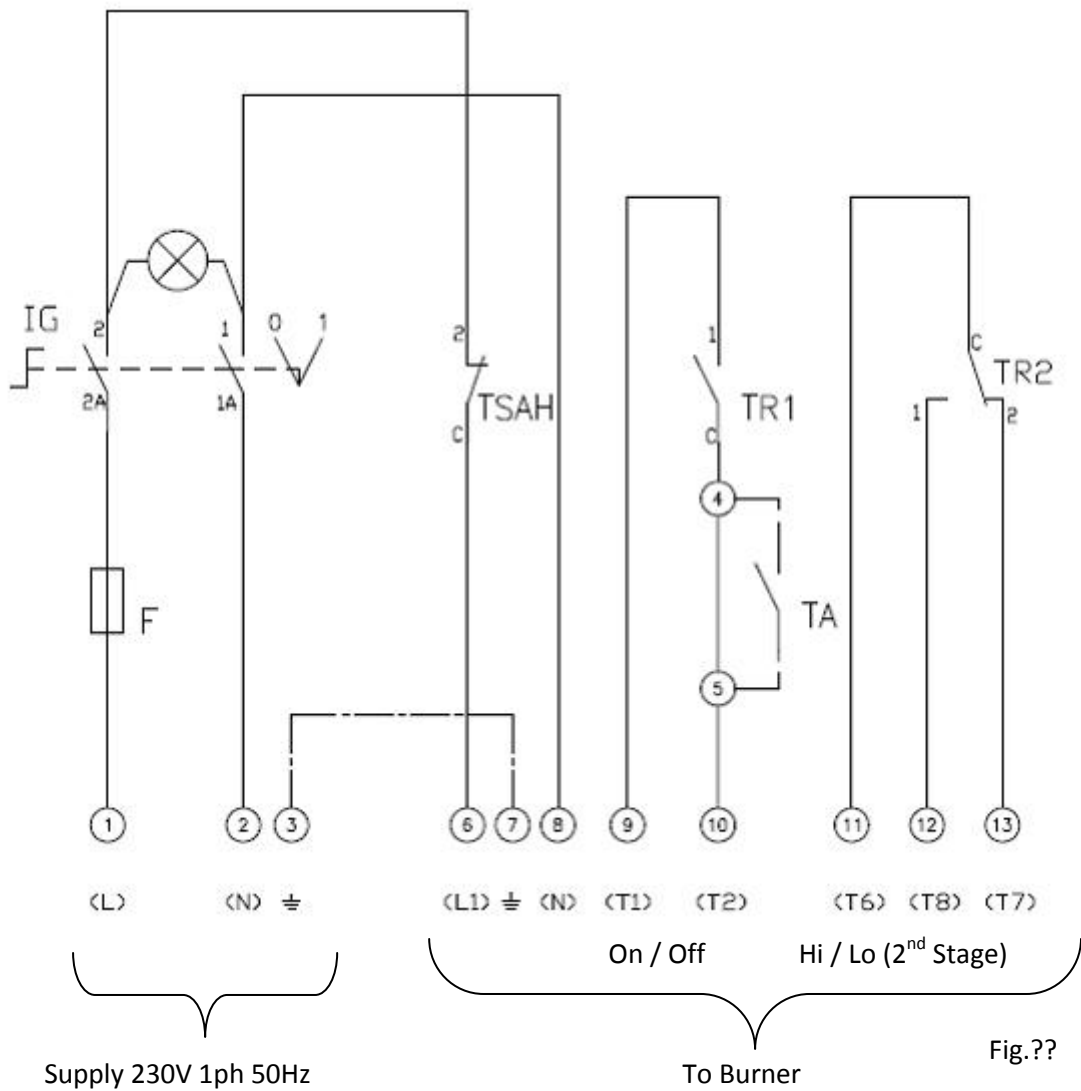

- IG Isolator
- TSAH Limit thermostat
- TR1 1st Stage thermostat
- TR2 2nd Stage thermostat
- TA External enable contacts (remove link if connected)
- F Fuse 4A

Preliminary checks before first firing

- Check that control panel instrument bulbs are correctly positioned in the thermostat pockets.
- Ensure that the flue tube turbulators do not protrude from the front of the tubes and that no foreign objects are within the combustion chamber.
- Check that any gaps between the burner blast tube and the combustion chamber door have been filled using high temperature ceramic fibre material.
- Check that the system has been filled with water and is vented and that the pressure is above 1bar and within the maximum limits of the plant.
- Ensure that an appropriately rated safety relief valve has been fitted and where necessary a pressure limiter.
- Check that combustion chamber door has been closed correctly.
- Check that pumps rotate freely and in the correct direction.
- Check fuel supplies have been appropriately tested for soundness, have been purged/vented and the fuel control valve is closed. Ask to view certificates. Gas supplies should be tested and purged in accordance IGE/UP/1 or IGE/UP/1A as appropriate
- Check that the ventilation provision meets with the appropriate standards.
- Check that the power supply is of the appropriate rating and adequately fused and that an isolator is positioned adjacent to the boiler.
- Ensure a heat load is available.
- Check that flue pipe is securely connected /sealed onto appliance

First start up

- Refer to the instructions supplied with the burner
- Check that appropriate sized nozzles have been fitted (oil fired burner).
- Check security and condition of flexible fuel lines (oil fired burner).
- Check electrode condition, positioning and gaps as specified in the burner manufacturer's instructions
- Make burner pre-settings for head positioning and air settings
- Attach oil pressure gauge to burner oil pump (oil fired burner).
- Ensure temperature controls are calling for heat
- Turn on fuel supply at isolating valve

- Turn on boiler at isolator and on/off on boiler control panel – the burner should start its start-up and ignition process.
- Check gas train (gas burner) and any pipework between isolating valve and burner connection for leakage.
- Check oil lines / oil connections for soundness (oil burner).
- Adjust burner in accordance with the burner manufacturer's instructions and allow the burner to stabilise for approximately 10 – 15 minutes; following which take measurements of combustion gases, fuel throughput (gas burner) and making any further adjustments as necessary. Record measurements.
- Switch off boiler, remove any gauges and refit test points.
- Restart/stop boiler several times to check integrity of ignition system.
- Check combustion chamber door for correct sealing.
- Check flue joints for integrity.
- Check water connections for soundness.
- (For gas fired burner only), with burner firing, turn off gas supply and ensure burner goes to lockout. Wait 45 seconds, turn on gas supply, and press reset button on burner – ensure burner restarts normally.
- Set controls to normal operational settings.
- Instruct user on the operation of the boiler and its controls and safety functions.

User Instructions

- Following the successful installation and commissioning procedures, the user must be made aware of the lighting and operating instructions including a practical demonstration.
- This installation guide plus the burner instructions must be handed over for safe keeping and future reference.

Operation / Controls

- The control panel includes two control thermostats which allows for the operation of high / low firing (2 stage burners).
- The left hand thermostat is for the control of the first stage (low fire) and should be set to the actual final wanted flow temperature; the right hand thermostat is for the control of the second stage (high fire) and should be nominally set around 3-5 degrees lower than the first stage thermostat to allow the burner to reduce to its low fire setting as the final setpoint water temperature is approached.
- Care should be taken to ensure that the controls are set to avoid that the water temperature within the system remains at a level where the return water temperature is less than 60°C for gas firing or 50°C for oil firing.

SuperRAC-AR For Models 80 to 3600

- If a modulating burner is being used, then the 4 core burner connection lead (T6,T8,T7) should be ignored and not utilised. The thermostat sensing bulb for the 2nd stage control thermostat should not be located in the thermostat pocket, and the temperature sensor supplied with the modulating burner temperature controls can be substituted into the thermostat pocket in place of the 2nd stage thermostat sensing bulb.



Notes