

Service Manual Trucks

Group **645–602**
Power Steering Pumps
ZF/Vickers/LuK
All Models

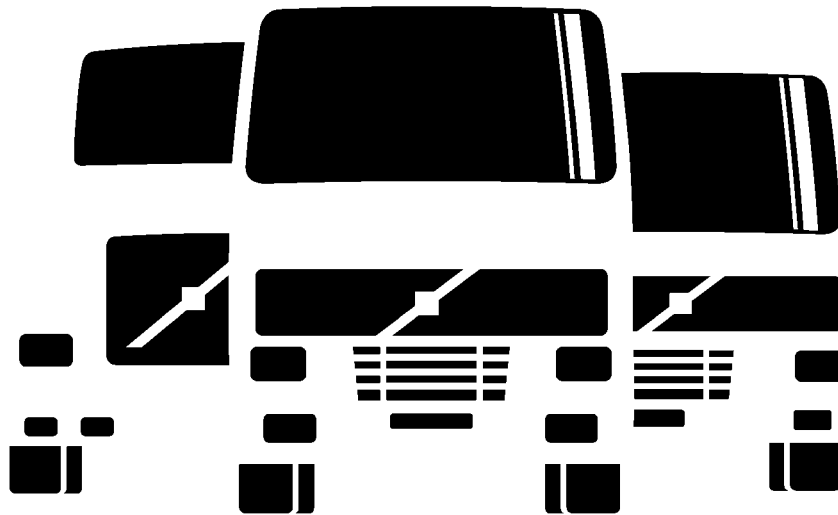

Foreword

The descriptions and service procedures contained in this manual are based on designs and methods studies carried out up to August 2003.

The products are under continuous development. Vehicles and components produced after the above date may therefore have different specifications and repair methods. When this is believed to have a significant bearing on this manual, supplementary service bulletins will be issued to cover the changes.

The new edition of this manual will update the changes.

In service procedures where the title incorporates an operation number, this is a reference to an V.S.T. (Volvo Standard Times).

Service procedures which do not include an operation number in the title are for general information and no reference is made to an V.S.T.

The following levels of observations, cautions and warnings are used in this Service Documentation:

Note: Indicates a situation, handling or circumstance which should be observed.

Caution: Indicates a potentially hazardous situation which, if not avoided, may result in minor or moderate injury or damage to property.

Warning: Indicates a potentially hazardous situation which, if not avoided, could result in death, serious injury or major damage to property.

Danger: Indicates an imminently hazardous situation which, if not avoided, will result in death or serious injury.

Volvo Trucks North America, Inc.
Greensboro, NC USA

Order number: PV776-TSP194907

© 2003 Volvo Trucks North America, Inc., Greensboro, NC USA

All rights reserved. No part of this publication may be reproduced, stored in retrieval system, or transmitted in any forms by any means, electronic, mechanical, photocopying, recording or otherwise, without the prior written permission of Volvo Trucks North America, Inc..

USA14074

Contents

General	3
Power Steering Pumps	3
Specifications	5
Power Steering Pump	5
Tools	7
Standard Tools	7
Special Tools	7
Special Equipment	8
Design and Function	9
Power Steering Pump	9
Control Valve	11
Pressure Relief Valve	11
Drive End Bearing Change	12
Power Steering Pumps, Exploded View	13
ZF Power Steering Pump	13
Vickers Power Steering Pump	14
LuK Power Steering Pump	15
Power Steering Pumps, Model Number Designations	16
Service Procedures	17
General Work Practices	17
Hydraulic Pressure, Test	20
Power Steering Pump, Flow Test	22
Power Steering Hydraulic System, Bleeding	24
Power Steering Pump, Removal	26
Power Steering Pump, Overhaul	28
ZF	28
Vickers	36
LuK	44
Power Steering Pump, Installation	54
Feedback	
Operation Numbers	

General

Power Steering Pumps

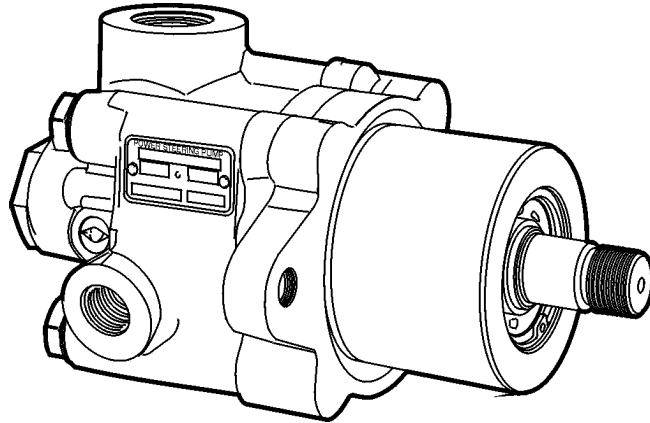

W6001351

This service manual describes the design, function, operation, and service procedures of the ZF, Vickers, and LuK power steering pumps installed on all models of Volvo Trucks.

Specifications

Power Steering Pump

Note: Due to customer preferences the actual pump installed on any vehicle may vary from the chart below. Direct any questions concerning this information to Volvo Trucks North America.

Engine	Steering	Type	Rotation	Relief	Shaft
VNM, VNL					
VE-12	TAS65/85/M100	VT72	cw	2175 (150)	20 dia straight shaft w/key
DD S60	TAS65/85/M100	LF73	ccw	2175 (150)	11 tooth spline
CU N14	TAS65/85/M100	LF73	cw	2175 (150)	11 tooth spline
CU ISX	TAS65/85/M100	LF73	cw	2175 (150)	11 tooth spline
CAT 3406	TAS65/85/M100	LF73	cw	2175 (150)	11 tooth spline
CU M11/ISM	TAS65/85/M100	LF73	ccw	2175 (150)	11 tooth spline
VE 12 (P-3039)	TAS65/85/M100	VT72	cw	2175 (150)	20 dia straight shaft w/key
VE 7 (P-3028)	TAS65/85/M100	VT79A	ccw	2175 (150)	20 dia straight shaft w/key

Engine	Steering	Type	Rotation	Relief	Shaft
VHD					
D12	TAS65	LuK, 21cc	cw	2000	Straight
D7	TAS65	LuK, 21cc	cw	2000	Straight
CU ISM	TAS65	LuK, 21cc	ccw	2000	Spline
CU M11	TAS65	LLuK, 21cc	ccw	2000	Spline
D12	TAS65	Luk, 25cc	cw	2175	Straight
D7	TAS65	LuK, 25cc	cw	2175	Straight
CU ISM	TAS65	TRW, 36cc	ccw	2175	Spline

Tools

Standard Tools

Power steering pump maintenance requires the use of many tools that are part of a technician's normal tool set. In addition, the following tools are required to perform maintenance procedures on the power steering pump.

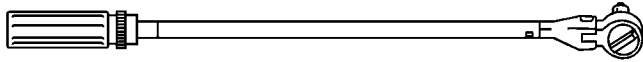

Torque wrench

Special Tools

The following special tools are required for work on power steering pumps. The tools can be ordered from a Volvo Parts dealer.



9991459



9991801



9991866

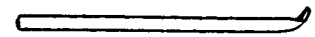

9992337



9992996



9992997

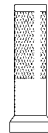

9994113



9994150



9996075

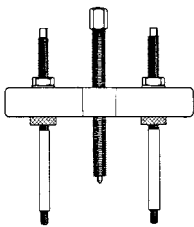

9985433

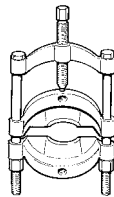

9985434

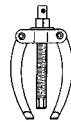

9986173



9986178

9991459	Drift	9994113	Sleeve
9991801	Handle	9994150	Sleeve
9991866	Drift	9996075	Sleeve
9992337	Pry bar	9985433	Puller
9992996	Drift	9985434	Puller
9992997	Spindle	9996173	Puller
9992658	Drift	9996178	Expander

Special Equipment

The following special equipment is required for testing the steering system. This equipment can be ordered from Kent-Moore by calling 1-800-328-6657.

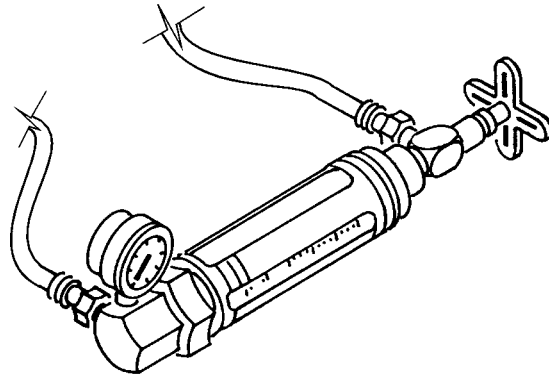

Flowmeter **J26487** with pressure gauge.

Design and Function

Power Steering Pump

Description

Power steering pumps installed on Volvo Trucks vehicles are from one of three manufacturers; ZF, Vickers, and LuK. All three pumps are vane pumps with integral control and relief valve. Operation of the three type pumps is similar. The major difference between the pumps is the location of the control and relief valve assembly. With ZF and Vickers pumps, the control and relief valve assembly is located adjacent and perpendicular to the shaft. On the LuK pump, the control and relief valve is directly behind the shaft.

Each pump manufacturer produces pumps with different ratings and specifications to accommodate the many engine and steering combinations.

ZF, Vickers, and LuK power steering pumps are vane type pumps designed to deliver high pressure fluid to the power steering gear. The pump body contains the pump assembly and the pressure control valve assembly. Power steering pumps are either belt driven by the engine crankshaft or direct driven by a gear in the engine timing cover. Pump rotation can be either clockwise or counterclockwise, depending on the engine manufacturer and model, and is indicated by an arrow on the cover at the rear of the pump.

There are two types of drive available with the LuK pumps; a gear or an eleven tooth spline. The splined shaft design does not generate excessive axial forces allowing the shaft bearing design to be replaced with a bushing (Refer to "LuK Power Steering Pump" page 15 for LuK pump design variations).

Operation

The pump shaft (1) is turned by the engine through a gear or a spline, which also turns the rotor (2). The vanes (3) which are in slots in the rotor, move with the rotor as well and are forced outward against the cam ring (4) by a combination of centrifugal force and hydraulic pressure. The cam ring is round on the outer edge to fit into the pump body but oval on the inside to allow the vanes to move outward and then inward. When the rotor turns, the volume of the space between the rotor, cam ring, and any two of the vanes changes, causing a change in the fluid pressure in that area.

When two vanes move past the suction channel (5), the area between them increases, creating a suction and trapping hydraulic fluid. The fluid is moved by the vanes along the inside of the cam ring. When the vanes approach the outlet channel side of the cam ring, the area between them becomes smaller, causing the pressure to increase which forces the oil out into the delivery channel (6).

The inner plate (7) guides oil from the reservoir to the suction channel (5). The outer plate directs the high pressure oil to the delivery channel (6) and to the rotor and vanes for lubrication.

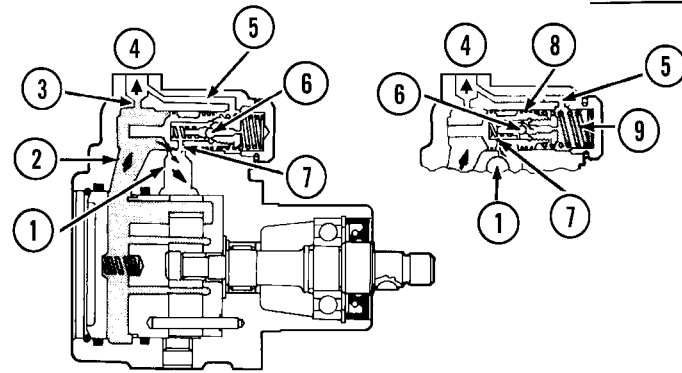

W6000005

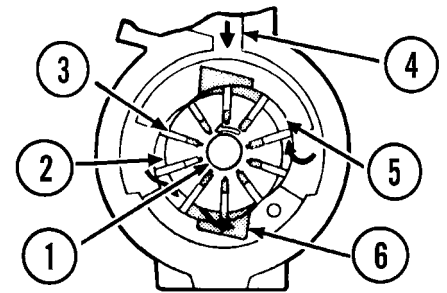

W6000004

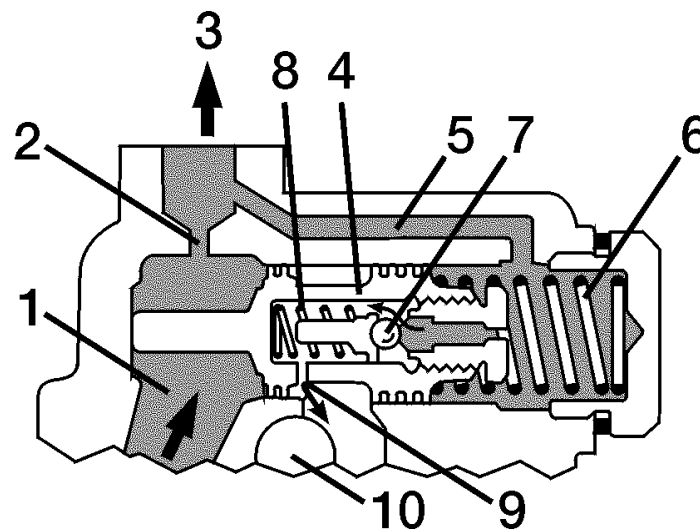

W6001350

- 1 Delivery channel
- 2 Delivery line
- 3 Orifice
- 4 Control valve
- 5 Connection channel
- 6 Spring
- 7 Relief valve
- 8 Relief valve spring
- 9 Relief passage
- 10 Suction channel

Control Valve

The function of the control valve is to regulate pump pressure and flow. The physical design of the control valve on the LuK pump differs from that of the ZF and Vickers pump but the principle of operation is the same. During normal operation, hydraulic fluid under pressure from the pump passes through the delivery channel (1), the orifice (2), and out the delivery line (3) to the steering gear. Fluid is also delivered to the rear of the control valve (4) through the connection channel (5). Due to the orifice, the pressure in the connection channel and in the rear of the control valve is slightly lower than the pressure in the delivery channel. As pump output pressure increases due to higher engine speed, the delivery channel pressure rises enough to overcome the force of the spring (6) behind the control valve, forcing the valve open (to the right) to allow some of the oil to flow back to the suction side of the pump (10). This action limits pump output pressure and is determined by the control valve spring.

Pressure Relief Valve

The control valve has another valve located inside it. This is the pressure relief valve. The pressure relief valve is either a ball valve (7) or a needle valve that is held closed by a spring (8). Oil pressure is supplied to the relief valve through a drilled passage in the rear of the control valve (4) piston.

In the event the pump flow is stopped, e.g. the steering gear is blocked, the pressure in the connection line (5) will be equal to the delivery line pressure, and the control valve (4) will be forced back to its normal position, closing off the passage to the suction side of the pump. This action will cause pump pressure to rise even more. When maximum pressure is reached, the ball valve (7) will be forced open against the spring (8), providing a passage for oil flow back to the suction side of the pump (10). This action will reduce the pressure in the connection line (5), causing the control valve to unseat (move to the right) and provide additional passage for oil to return to the suction line.

As pump pressure returns to normal, the relief valve closes and the control valve returns to its normal position.

Drive End Bearing Change

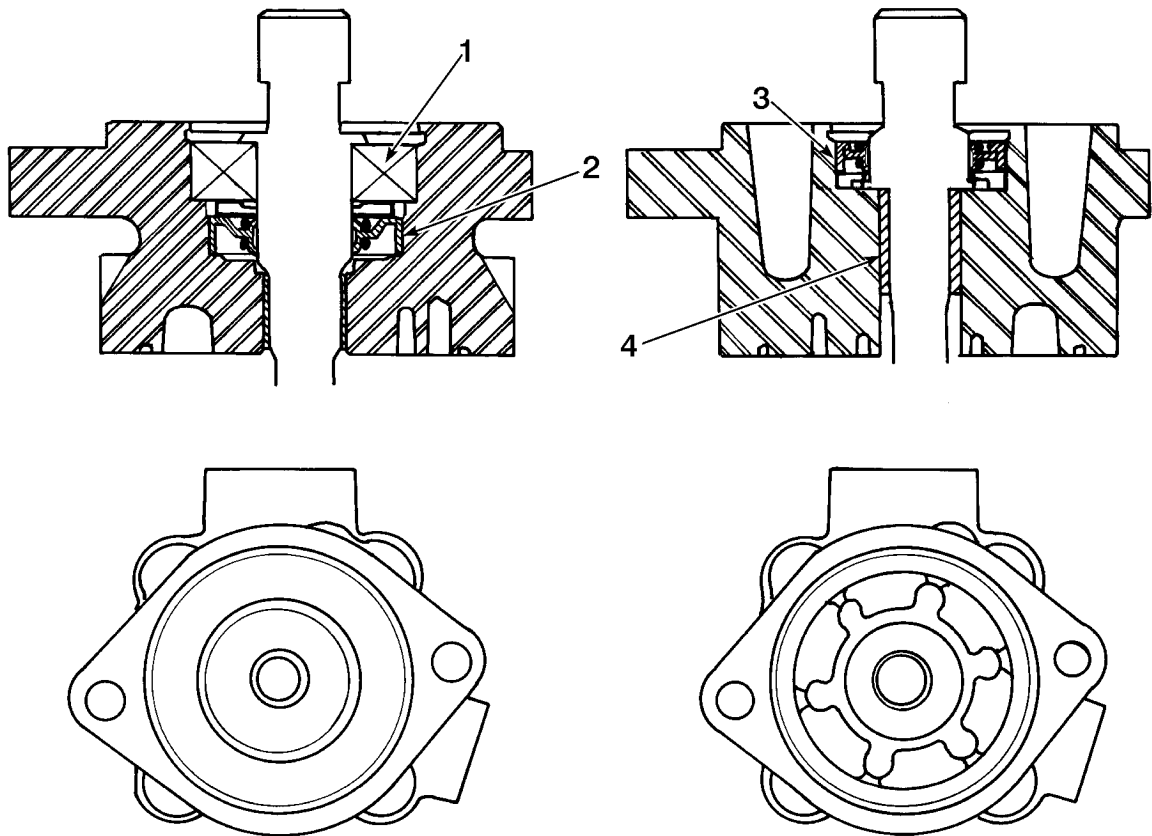

- 1 Bearing
- 2 Seal
- 3 Seal
- 4 Bushing

W6001429

The previous common bearing design is now offered in two versions depending on the drive option.

The LuK hydraulic pump, formerly sold as Vickers, is now driven either by a gear or an eleven tooth, splined shaft depending on the engine on which it is installed. The splined axle drive is used on all except Volvo and CAT 3306 engines.

A splined axle drive does not generate excessive axial forces and therefore the drive end bearing and housing has been redesigned with a bushing in place of the ball bearing. Pumps designed for axial and radial drive forces (gear attached to pump) are still designated the VT-series pumps. Pumps redesigned for radial drive forces only (splined drive shaft) are now designated the LF-series pumps.

Power Steering Pumps, Exploded View

ZF Power Steering Pump

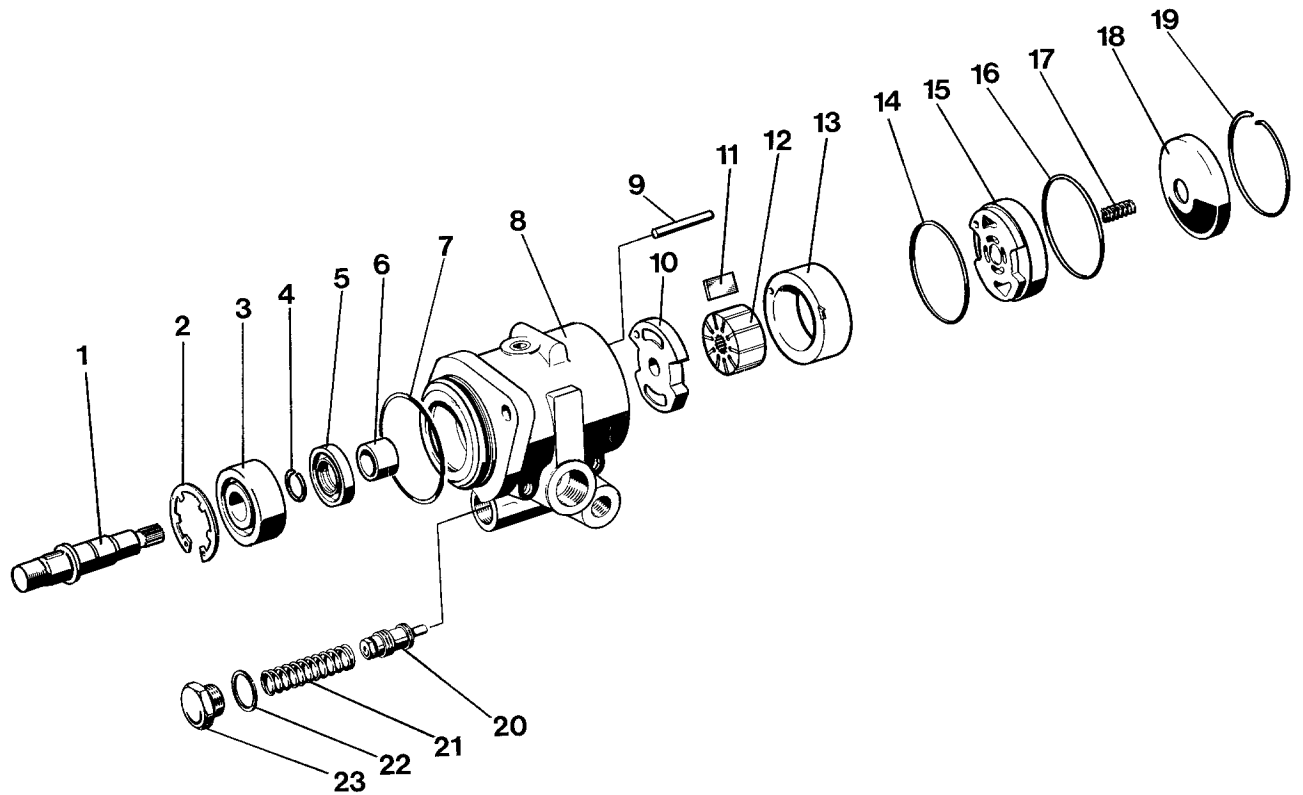

- 1 Shaft
- 2 Snap ring
- 3 Bearing
- 4 Lock ring
- 5 Seal
- 6 Bushing
- 7 O-ring
- 8 Body
- 9 Guide pin
- 10 Inner plate
- 11 Vane
- 12 Rotor

- 13 Cam ring
- 14 O-ring
- 15 Outer plate
- 16 O-ring
- 17 Spring
- 18 Cap
- 19 Lock ring
- 20 Control valve
- 21 Spring
- 22 Copper washer
- 23 Plug

T6006637

Vickers Power Steering Pump

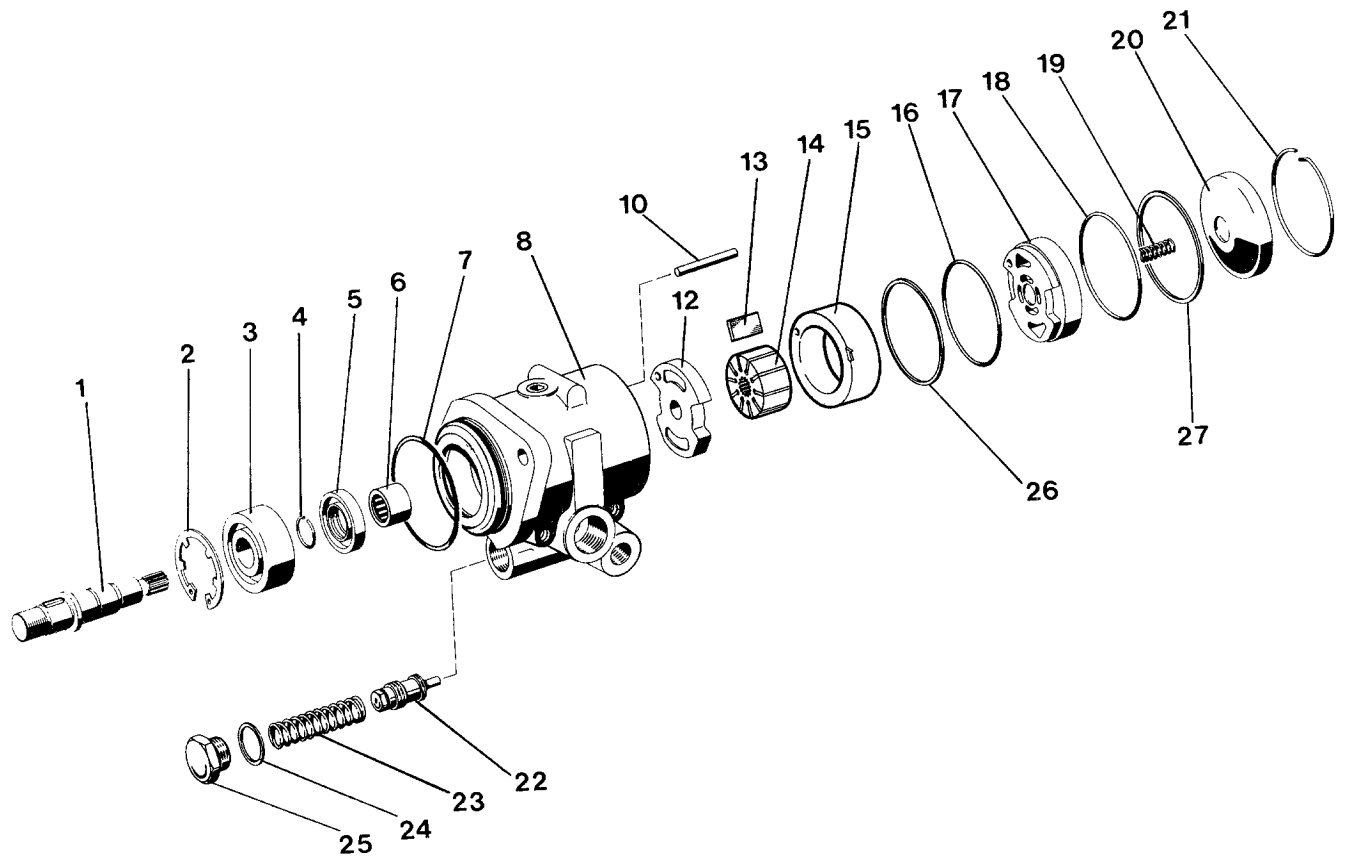

- 1 Shaft
- 2 Snap ring
- 3 Bearing
- 4 Lock ring
- 5 Seal
- 6 Needle bearing
- 7 O-ring
- 8 Body
- 9 Guide pin
- 10 Inner plate
- 11 Vane
- 12 Rotor
- 13 Cam ring
- 14 Support ring

- 15 O-ring
- 16 Outer plate
- 17 O-ring
- 18 Spring
- 19 Support ring
- 20 Cap
- 21 Lock ring
- 22 Control valve
- 23 Spring
- 24 Washer
- 25 Plug
- 26 Support ring
- 27 Support ring

T6006636

LuK Power Steering Pump

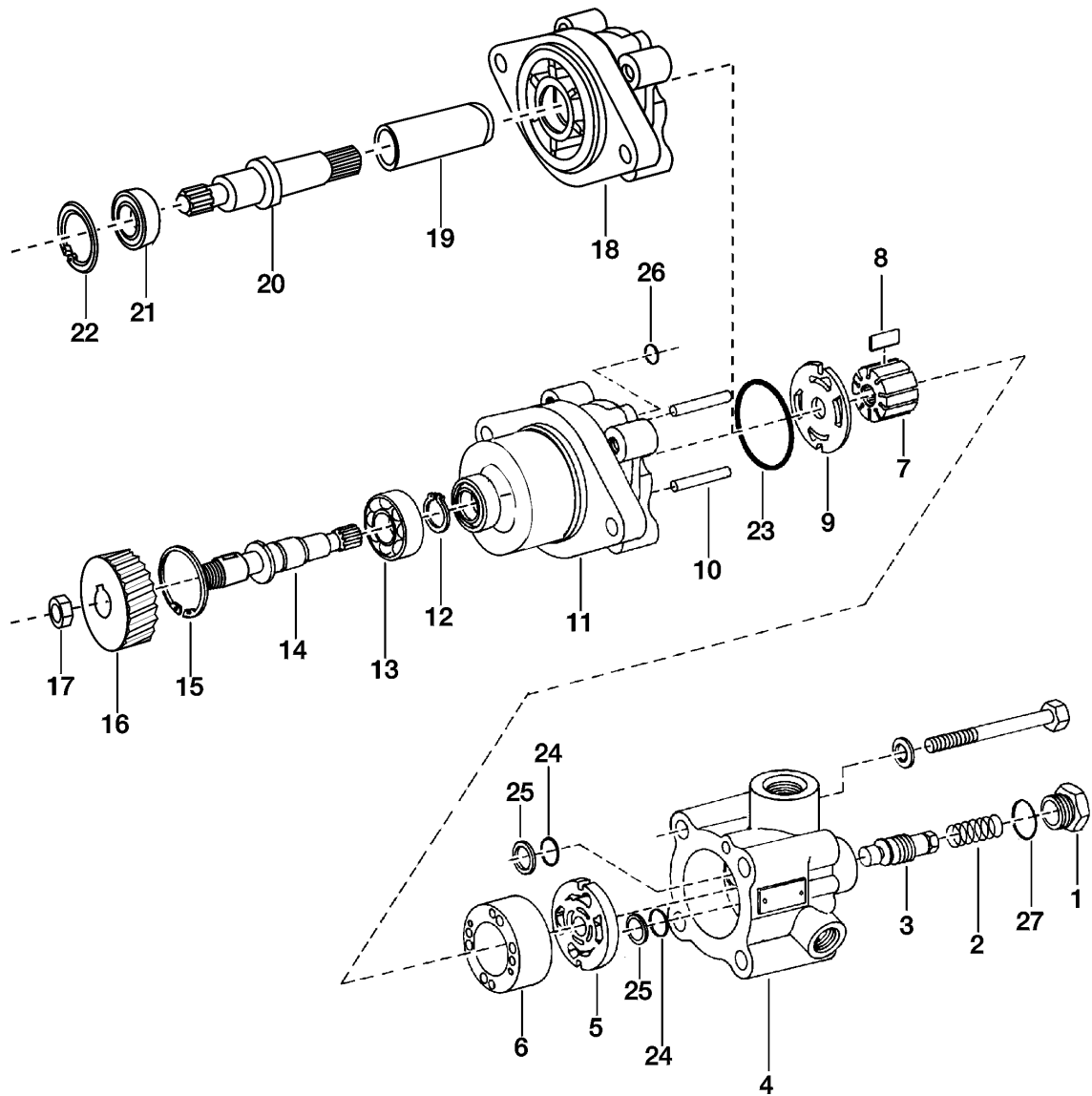

- 1 Plug
- 2 Spring
- 3 Control valve
- 4 Housing
- 5 Wear plate
- 6 Casing ring
- 7 Rotor
- 8 Vane
- 9 Wear plate
- 10 Dowel pin
- 11 Flange
- 12 Retaining ring
- 13 Bearing
- 14 Shaft

- 15 Retaining ring
- 16 Gear
- 17 Lock nut
- 18 Flange
- 19 Bushing
- 20 Shaft
- 21 Seal
- 22 Retaining ring
- 23 O-ring
- 24 O-ring
- 25 Backup ring
- 26 O-ring
- 27 O-ring

W6001363

Power Steering Pumps, Model Number Designations

XXXX-XX-XX-XXX-X-X-X-X-XX-10

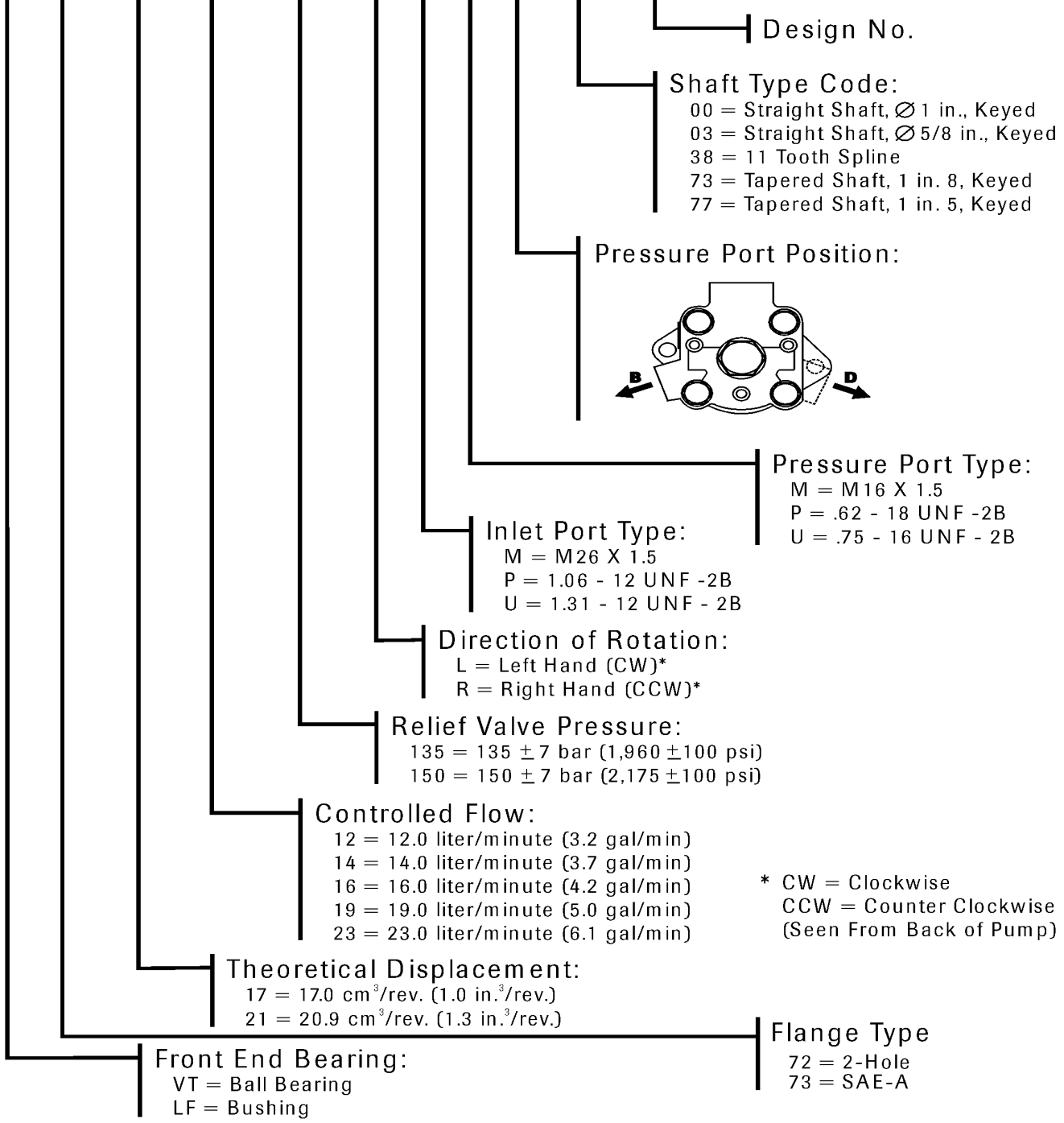

v640596
W600866

Service Procedures

General Work Practices

To ensure personal safety and to help avoid accidental damage to power steering pump components, always follow these guidelines any time work is performed on the power steering pump.

DANGER

Before working on a vehicle, set the parking brakes, place the transmission in neutral and chock the wheels. Failure to do so can result in unexpected vehicle movement and can cause serious personal injury or death.

CAUTION

Improper equipment operation may occur if the control valve is not in the same tolerance group as the pump housing. The valve and the pump housing are stamped with corresponding numerals to indicate the tolerance group, such as 1 on the pump and I on the valve, or 2 and II. Replacing the valve with a valve of the wrong tolerance group could result in improper control valve operation and pump damage.

CAUTION

Component damage may occur if the cleanliness of the hydraulic system is not maintained. The area around any component to be disconnected/connected should be cleaned prior to disconnecting/connecting. Used hydraulic fluid should never be put into the hydraulic system. Dirt in the hydraulic system can damage the power steering pump or steering gear. Failure to follow these precautions could result in damage to the steering system hydraulic components.

WARNING

HOT ENGINE! Keep yourself and your test equipment clear of all moving parts or hot engine parts and/or fluids. A hot engine and/or fluids can cause burns or can permanently damage test equipment.

**WARNING**

Always wear appropriate eye protection to prevent the risk of eye injury due to contact with engine debris or fluids.

**CAUTION**

Possible component damage. All power steering pump components must be lubricated with power steering fluid during assembly. Failure to lubricate pump components could result in pump damage when it is operated.

**CAUTION**

Possible component damage. Use protective jaw caps on the vise. Failure to do so can cause damage to the pump.

**CAUTION**

When the pump is overhauled, always replace all O-rings and support rings in the pump. Failure to replace these parts could result in pump failure.

1

Always park the vehicle on a level surface, chock the front wheels and release the parking brakes.

2**WARNING**

Personal injury hazard. A faulty power steering pump high pressure relief valve may not relieve pump pressure. Closing the high pressure shut off valve may cause severe pump damage or high pressure hoses to rupture. Watch the pressure closely when closing the shut off valve. If pressure rises rapidly or exceeds 17236 kPa (2500 psi), immediately open the shut off valve. Failure to follow these precautions could result in severe equipment damage or personal injury.

**WARNING**

Never check for leaks with your hands. Oil released under high pressure can penetrate the skin causing severe injury.

Determine the pump minimum output pressure from the pump nameplate.

3

Install a steering system analyzer in the high pressure fluid line between the pump and the steering gear. The analyzer should include a pressure gauge, flow meter, and shut off valve.

4

Place a thermometer in the fluid reservoir.

5

Start the engine and warm the hydraulic system by partially closing the shut off valve until the pressure gauge reads 6900 kPa (1000 psi). When fluid temperature reaches 52 – 57°C (125 – 135°F), open the shut off valve.

6900 kPa (1000 psi)

6453-06-02-01 Hydraulic Pressure, Test

See "General Work Practices" page 17 for important service information before beginning this procedure.

DANGER

Before working on a vehicle, set the parking brakes, place the transmission in neutral, and block the wheels. Failure to do so can result in unexpected vehicle movement and can cause serious personal injury or death.

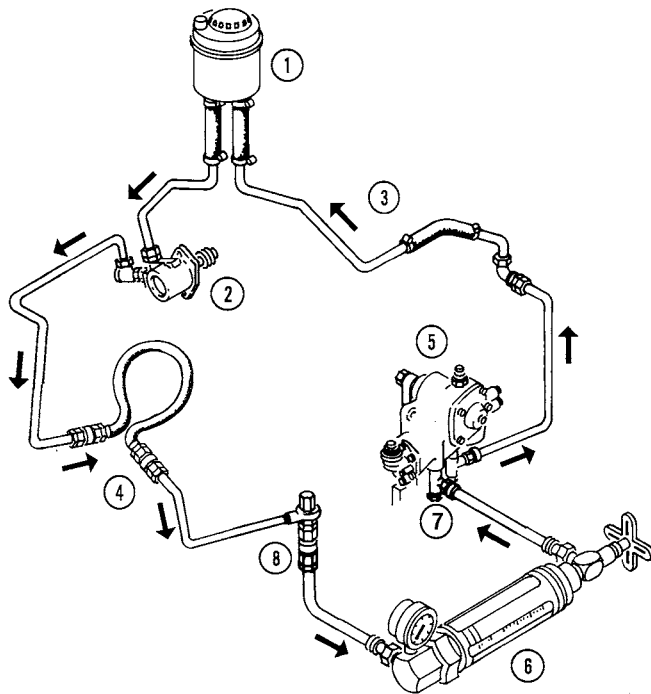

W6000052

Test meter connected for pressure/flow checks.

- 1 Power steering reservoir
- 2 Power steering pump
- 3 Return line
- 4 Pressure line
- 5 Steering gear
- 6 Gauge J26487
- 7 Tool J38282
- 8 Tool J35545
- 9 Tool J35545

- 1
Install a flow meter with a pressure gauge.

2**CAUTION**

Potential pump damage. Do NOT leave the shut off valve fully closed for more than 5 seconds. Leaving the shut off valve fully closed too long could result in excessive fluid temperatures and pump damage.

Close the shut off valve and read the pressure gauge.
Immediately open the shut off valve.

3

If pump pressure was below the minimum value listed on the pump nameplate, repair or replace the pump.

4

Allow the fluid to cool to 52 – 57°C (125 – 135°F) before performing other tests or shutting off the engine.

6453-06-02-02 Power Steering Pump, Flow Test

See "General Work Practices" page 17 for important service information before beginning this procedure.

DANGER

Before working on a vehicle, set the parking brakes, place the transmission in neutral, and block the wheels. Failure to do so can result in unexpected vehicle movement and can cause serious personal injury or death.

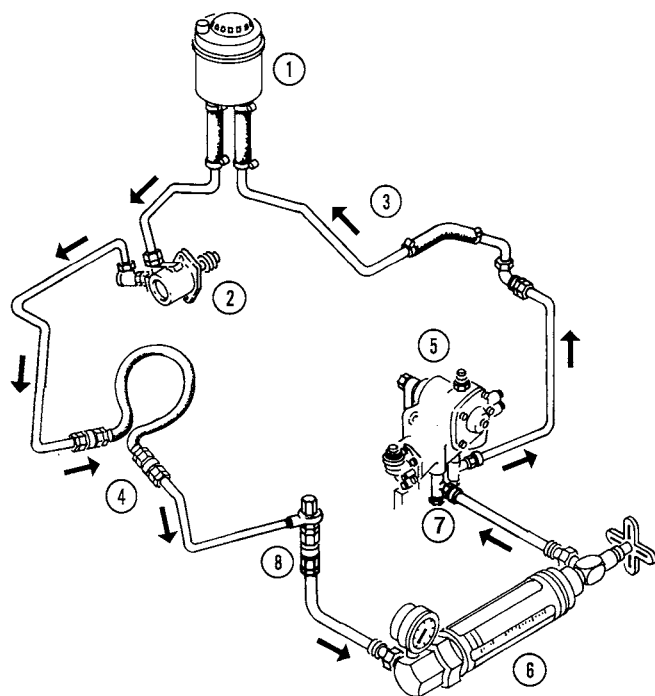

W6000052

Test meter connected for pressure/flow checks.

- 1 Power steering reservoir
- 2 Power steering pump
- 3 Return line
- 4 Pressure line
- 5 Steering gear
- 6 Gauge J26487
- 7 Tool J38282
- 8 Tool J35545
- 9 Tool J35545

1
Install a flow meter with a pressure gauge.

2
Ensure the engine is idling and fluid temperature is between 52 to 57°C (125 to 135°F).

3
Note the fluid flow rate.

4**CAUTION**

Possible equipment damage. The substeps within this step must be performed in rapid succession. Leaving the shut off valve closed for too long could result in excessive fluid temperatures and pump damage.

Fully close the shut off valve. When pump relief pressure is reached, verify the flow rate is zero. Immediately open the shut off valve. Verify the flow rate rapidly returns to the value previously noted for idle engine rpm.

5

Allow the fluid to cool to 52 – 57°C (125 – 135°F).

6

Set engine speed at governed rpm, then note the fluid flow rate.

7**CAUTION**

Possible equipment damage. The substeps within this step must be performed in rapid succession. Leaving the shut off valve closed for too long could result in excessive fluid temperatures and pump damage.

Fully close the shut off valve. When pump relief pressure is reached, verify the flow rate is zero. Immediately open the shut off valve. Verify the flow rate rapidly returns to the value previously noted for governed engine rpm.

8

Allow the fluid to return to 52 – 57°C (125 – 135°F).

9

If flow rate did not immediately return to the noted flow rate, the pump is malfunctioning and should be repaired or replaced.

10

If flow rates for idle and governed engine rpm were not within specification (see “Power Steering Pump” page 5.), the pump is malfunctioning and should be repaired or replaced.

6459-05-03-01

Power Steering Hydraulic System, Bleeding

See "General Work Practices" page 17 for important service information before beginning this procedure.

Note: Ensure steering gear poppets are set prior to performing this procedure.

1



DANGER

Before working on a vehicle, set the parking brakes, place the transmission in neutral, and block the wheels. Failure to do so can result in unexpected vehicle movement and can cause serious personal injury or death.



WARNING

HOT ENGINE! Keep yourself and your test equipment clear of all moving parts or hot engine parts and/or fluids. A hot engine and/or fluids can cause burns or can permanently damage test equipment.



WARNING

Always wear appropriate eye protection to prevent the risk of eye injury due to contact with engine debris or fluids.

Fill the fluid reservoir nearly full. Do NOT steer.

2

Start and run the engine for 10 seconds, then shut it off. Check the reservoir and refill if necessary. Repeat this step at least three times.

3**CAUTION**

Equipment damage. Do NOT allow the fluid level to drop significantly or run out of the reservoir. This may introduce air into the system which could result in damage to the steering gear.

Start the engine and let it idle for two minutes, then shut it off. Check the reservoir and refill if necessary. Do NOT steer.

4

Start the engine. Steer the vehicle from full left to full right several times. Add fluid as necessary to maintain it at the full line on the dipstick.

6453-01-01-01 Power Steering Pump, Removal

See "General Work Practices" page 17 for important service information before beginning this procedure.

DANGER

Before working on a vehicle, set the parking brakes, place the transmission in neutral and chock the wheels. Failure to do so can result in unexpected vehicle movement and can cause serious personal injury or death.

WARNING

HOT ENGINE! Keep yourself and your test equipment clear of all moving parts or hot engine parts and/or fluids. A hot engine and/or fluids can cause burns or can permanently damage test equipment.

CAUTION

Component damage may occur if the cleanliness of the hydraulic system is not maintained. The area around any component to be disconnected should be cleaned prior to disconnecting. Used hydraulic fluid should never be put into the hydraulic system. Failure to follow these precautions could result in damage to the steering system hydraulic components.

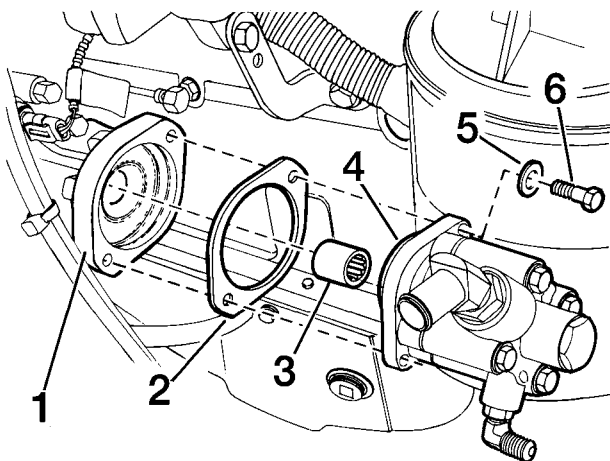

Spline driven pump

- 1 Engine flange
- 2 Gasket
- 3 Drive coupler
- 4 Pump flange
- 5 Washer
- 6 Mounting bolt

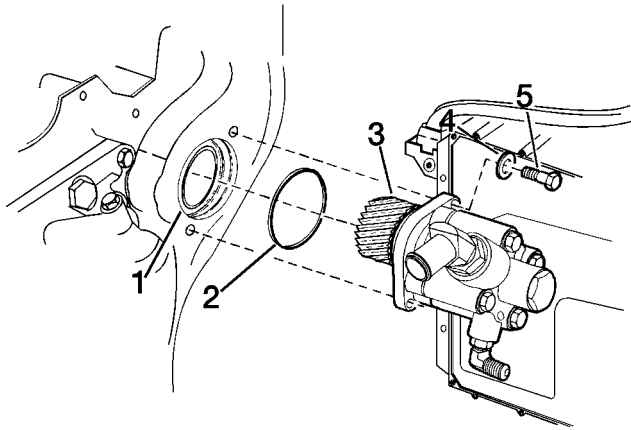

Gear driven pump.

- 1 Mounting hole
- 2 O-ring
- 3 Drive gear
- 4 Pump flange
- 5 Mounting bolt

1
Place a drain pan under the vehicle to catch power steering fluid.

2
Disconnect the two fluid lines from the pump.

3
Remove the two mounting bolts and pull the pump off the engine.

4
Clean the mating surfaces on the engine and on the pump.

6453-04-04-01 Power Steering Pump, Overhaul

See "General Work Practices" page 17 for important service information before beginning this procedure.

WARNING

Always wear appropriate eye protection to prevent the risk of eye injury due to contact with engine debris or fluids.

CAUTION

Possible component damage. Strict cleanliness must be observed when performing power steering pump maintenance. Dirt in the hydraulic system can damage the power steering pump or steering gear.

CAUTION

Possible component damage. All power steering pump components must be lubricated with power steering fluid during assembly. Failure to lubricate pump components could result in pump damage when it is operated.

Special tools: 9991459, 9991801, 9991866, 9992337, 9992996, 9992997, 9994113, 9994150, 9995433, 9995434, 9996173, 9996178

ZF

Disassembly

1

Clean the outside of the pump body. Remove and discard the external O-ring from the body.

2

CAUTION

Possible component damage. Use protective jaw caps on the vise. Failure to do so can cause damage to the pump.

Clamp the drive gear in a vise with protective jaw caps. Remove the drive gear nut.

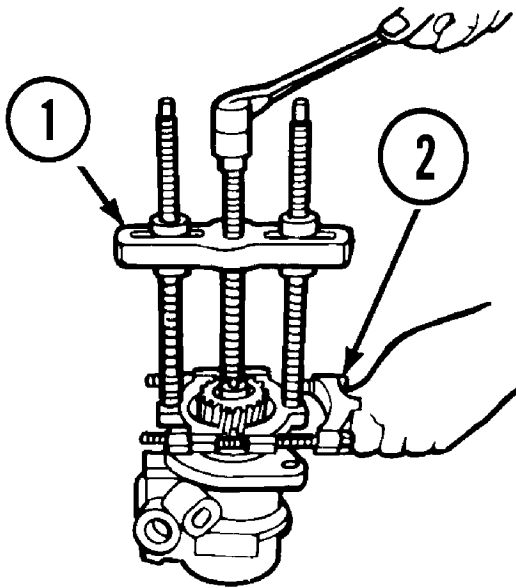

W6000007

3

Place the pump in a vise.
Use puller 9995434 (1) and 9995433 (2) to remove the drive gear.

9995433
, 9995434

4

Remove the lock ring and the end cap.

Note: Be careful not to lose the spring under the cap.

5

Remove the outer plate (1).

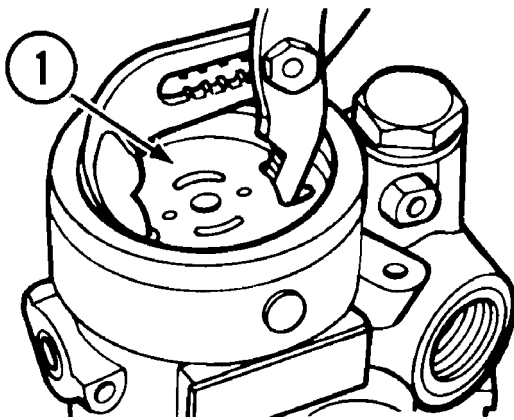

W6000008

6

Turn the pump over and take out the rotor, vanes and cam ring.

7

Remove the two guide pins.

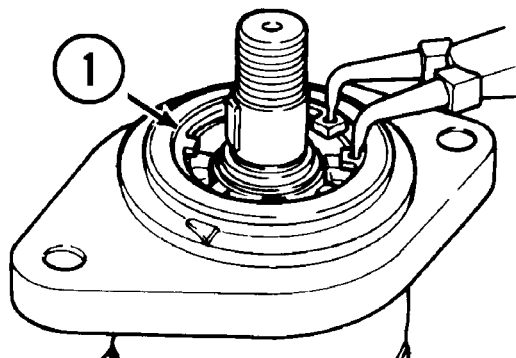

W6000009

8

Remove the snap ring (1) from the drive bearing end of the pump.

9

Using a brass drift, tap out the shaft and bearing.

10

Using a 16 mm (5/8 in.) brass drift, tap the inner plate out from the drive side.

11

Press out the needle bearing using drift 9991866.

 9991866
12

Tap out the seal using drift 9992337 (1), or equivalent.

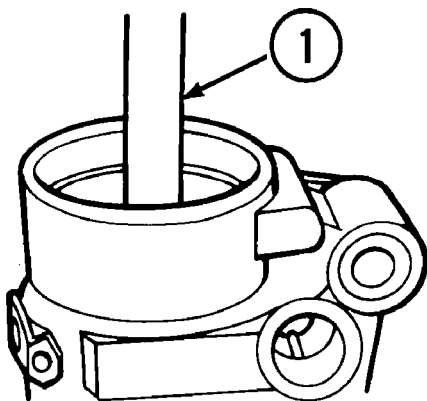
 9992337

W6000010

13

Unscrew the plug for the control valve. Pull out the spring, washers, and control valve.

Note: Note the number of washer for reassembly.

Cleaning and Inspection

1

Clean all pump parts thoroughly.

2

Check the shaft for wear at the seal surface and at the needle bearing surface. Inspect the splines and threads for damage. Replace the shaft if necessary.

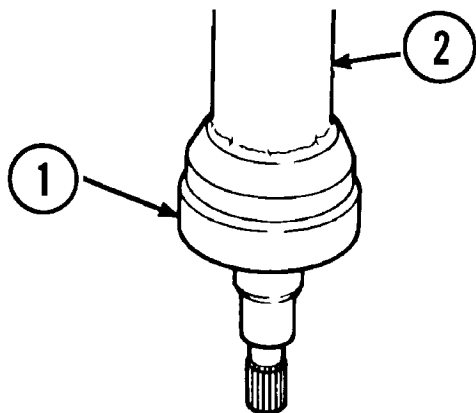

W6000011

3

Check the bearing (1) on the shaft. If damaged replace the bearing as follows:

- a Remove the lock ring.
- b Press the bearing off using sleeve 9994113 (2).
- c Press a new bearing on the shaft using sleeve 9994113.
- d Install the lock ring.

9994113

4

Check the outer and inner plates for wear and scoring. Pay particular attention to the surfaces that ride against the rotor.

5

Check the rotor, cam ring, and vanes for wear. Ensure the vanes fit easily in the rotor.

Note: If replacement is necessary, the rotor, vanes, and cam ring must be replaced as a unit.

6

Replace the seal, O-rings, and support rings on the shaft.

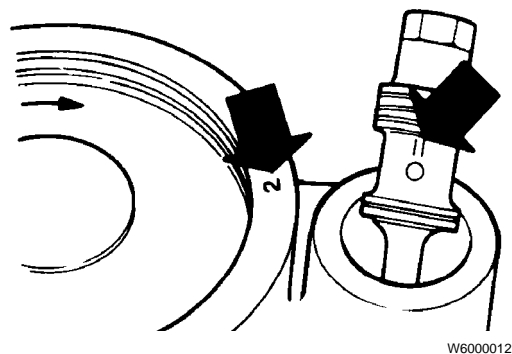

W6000012

7

Check that the control valve does not bind in the body. If binding is evident, replace the control valve.

CAUTION

Improper equipment operation may occur if the control valve is not in the same tolerance group as the pump housing. The valve and the pump housing are stamped with corresponding numerals to indicate the tolerance group, such as 1 on the pump and I on the valve, or 2 and II. Replacing the valve with a valve of the wrong tolerance group could result in improper control valve operation and pump damage.

8

If the control valve is to be reused, disassemble the valve using pliers clamped over the hole in the side of the valve.

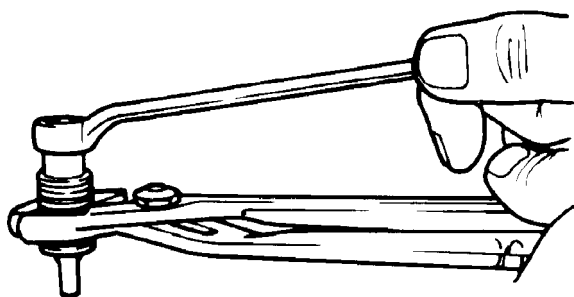

W6000013

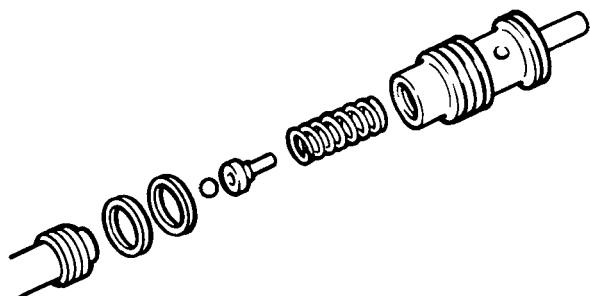

W6000014

9

Clean and inspect the valve components. If any of the valve parts are damaged, replace the complete valve assembly. If the valve is not damaged, lubricate the parts with oil and reassemble the valve.

Note: Ensure the same number of washers are used during valve assembly that were removed during disassembly. The number of washers determines control valve operating pressure.

Assembly

CAUTION

When the pump is overhauled, always replace all O-rings and support rings in the pump. Failure to replace these parts could result in pump failure.

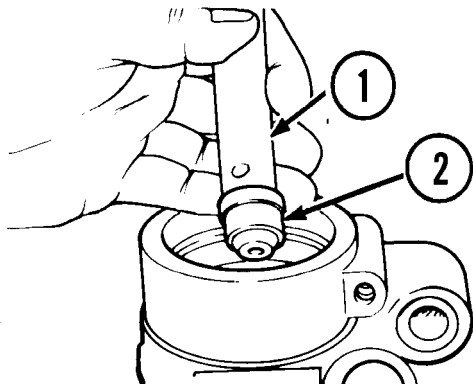

W6000015

1

Using drift 9992996 (1), press the needle bearing (2) in until the drift bottoms in the pump body.

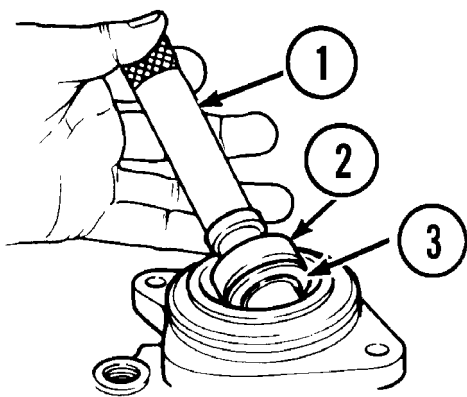
 9992996

W6000016

2

Apply grease between the seal lips and install the seal using sleeve 9994150 (2) and handle 9991801 (1). Ensure the flat side of the seal faces outward.

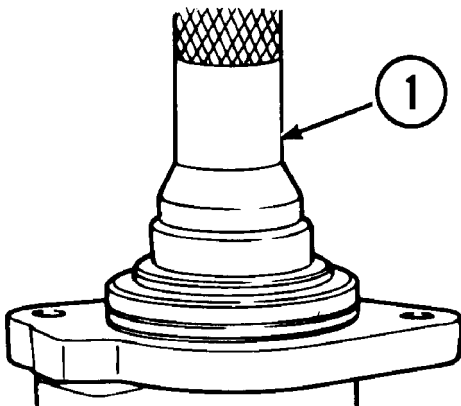
 9991801
 , 9994150

W6000017

3

Install the shaft and bearing in the pump body. Press in the bearing using sleeve 9994113 (1).

 9994113

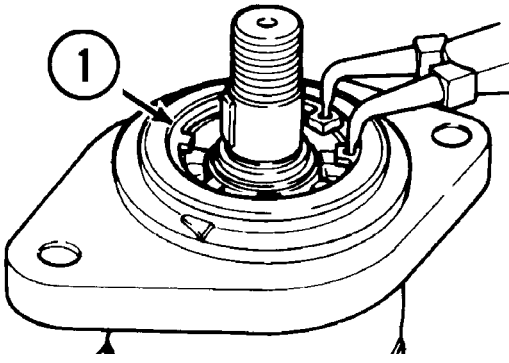

W6000009

- 4
Install the snap ring (1).

- 5
Install the O-rings in the pump body.

Note: Refer to "ZF Power Steering Pump" page 13 for correct O-ring placement. The inner O-ring (14) and support ring (15) have a smaller diameter than the outer O-ring (17) and support ring (19).

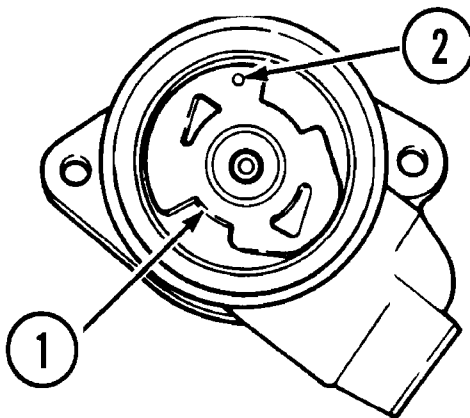

W6000018

- 6
Install the guide pins (2) (if removed) and inner plate (1) in the pump body. Tap the plate into position using a brass drift.

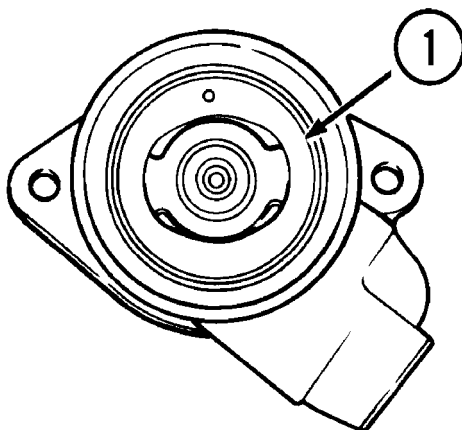

W6000019

- 7
Place the cam ring (1) in the pump body with the recess facing the direction of normal pump rotation.

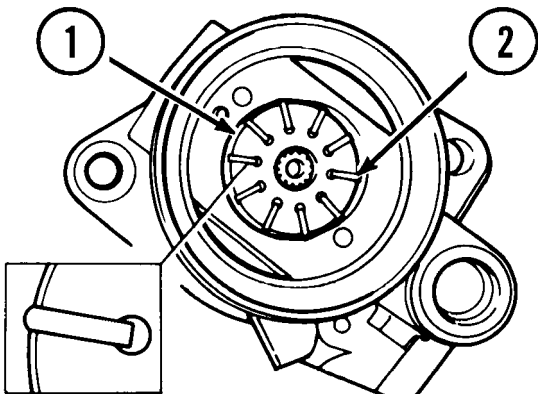

W600020

8

Place the rotor (1) in the pump body. The smooth drilling in the internal splines must face the drive side. Place the vanes (2) in the rotor with the rounded sides facing outward toward the cam ring.

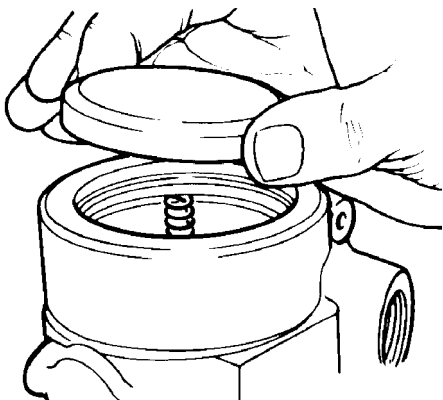

W600021

9

Place the outer plate on the cam ring with the guide pins in their respective holes.

10

Place the springs on the outer plate and install the cap. Press the cap down with clamp pliers and install the lock ring.

11

Install the control valve, washers, and spring. Install the control valve plug.

12

Place the wedge key in the shaft if it was removed. Heat the drive gear to approximately 100°C (212°F) and install it on the shaft.

13

Install the washer (if used) and install the nut. Torque the nut to 100 Nm (74 ft-lb).

100 Nm
(74 ft-lb)

14

Install a new O-ring on the pump body.

Vickers

Disassembly

1

Clean the outside of the pump body. Remove and discard the external O-ring from the body.

2



CAUTION

Possible component damage. Use protective jaw caps on the vise. Failure to do so can cause damage to the pump.

Clamp the drive gear in a vise with protective jaw caps. Remove the drive gear nut.

3

Clamp the pump in a vise.

Use puller 9995433 (1) and 9995434 (2) to remove the drive gear.

9995433
, 9995434

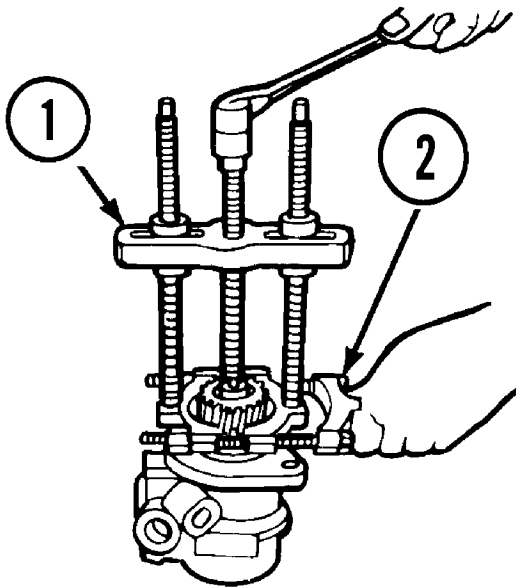

W600007

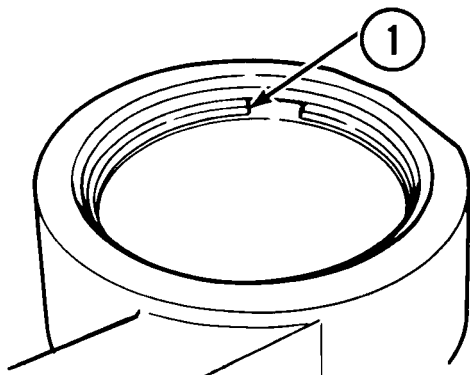

W6000024

4

Remove the lock ring, cap, and spring from the rear of the pump.

- 5**
Remove the two guide pins.

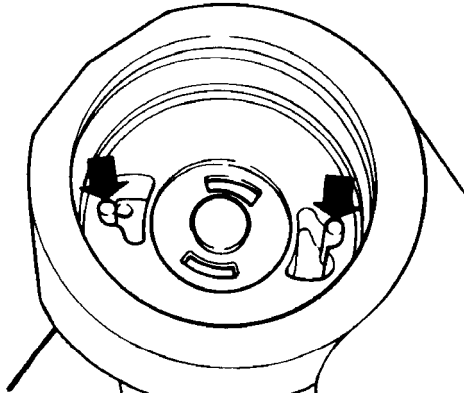

W6000026

- 6**
Remove the O-ring (1) from inside the pump body.

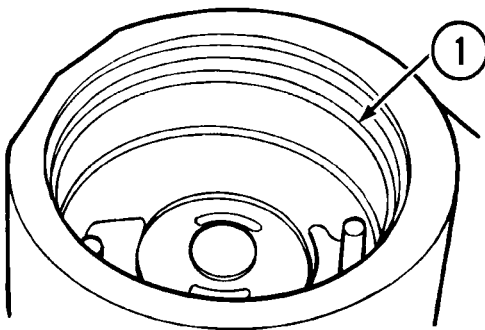

W6000025

- 7**
Turn the pump over and tap it against a flat surface to remove the outer plate (1), cam ring, rotor, and vanes (2), and inner plate (3).

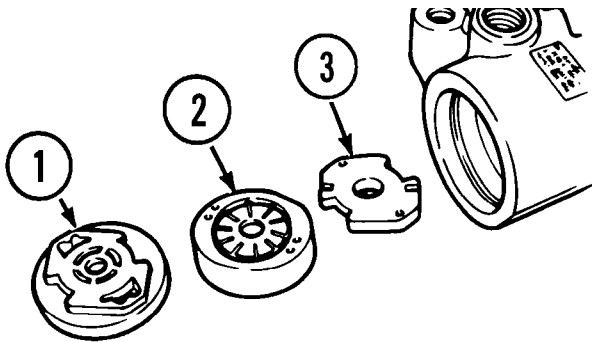

W6000027

- 8**
Remove the O-ring (1) from inside the pump body.

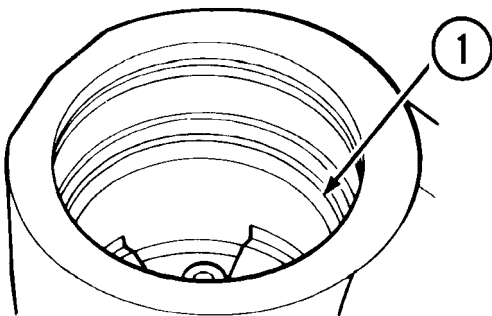

W6000028

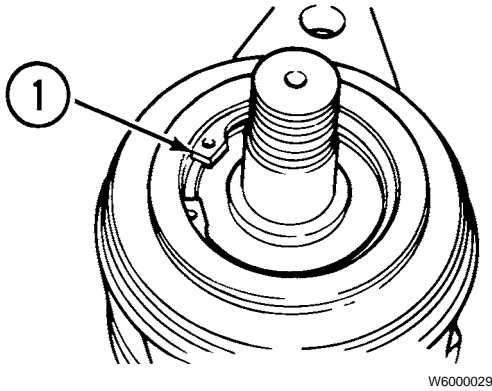

- 9**
Remove the snap ring (1) from the front of the pump body.

- 10**
From inside the pump body, tap out the shaft and bearing as an assembly.

- 11**
Remove the control valve plug.

Note: Note the number of washers behind the control valve plug.

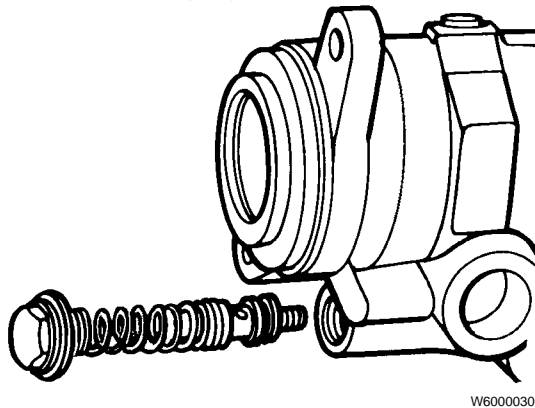

- 12**
Remove the spring and control valve assembly from the pump body.

- 13**
Pull out the seal using puller 9996173 (1) and expander 9996178 (2).

9996173
, 9996178

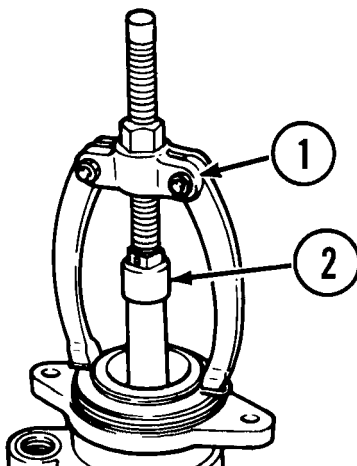

Cleaning and Inspection

1

Clean all pump parts thoroughly.

2

Check the shaft for wear at the seal surface and at the wear surface for the bushing. Inspect the splines and threads for damage. Replace the shaft if necessary.

3

Check the bearing on the shaft. If damaged replace the bearing as follows:

- a Remove the lock ring.
- b Press the bearing off using sleeve 9994113 (1).
- c Press a new bearing on the shaft using sleeve 9994113.
- d Install the lock ring.

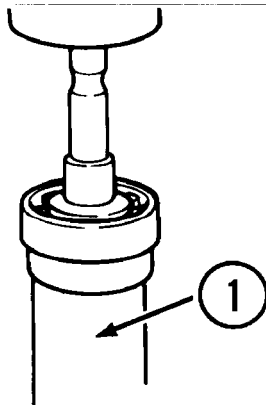

W6000032

9994113

4

Replace the seal, O-rings, and support rings on the shaft.

5

Inspect the bushing in the pump body for wear. If damaged replace the bushing as follows:

- a Press the bushing out using drift 9991459 (1).
- b Press a new bushing in flush to the edge where the inner plate fits using sleeve 9994113.

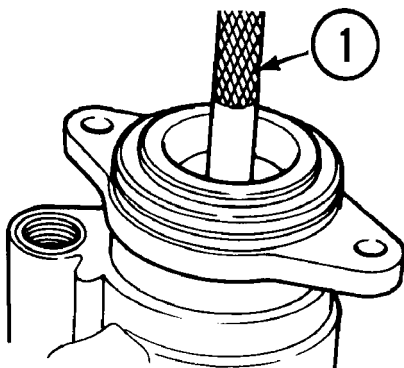

W6000033

9991459
, 9994113

6

Check the outer and inner plates for wear and scoring. Pay particular attention to the surfaces that ride against the rotor.

7

Check the rotor, cam ring, and vanes for wear. Ensure the vanes fit easily in the rotor. If replacement is necessary, the rotor, vanes, and cam ring must be replaced as a unit.

8

Check that the control valve does not bind in the body. If binding is evident, replace the control valve.

9

If the control valve is to be reused, disassemble the valve using pliers clamped over the hole in the side of the valve.

10

Clean and inspect the valve components. If any of the valve parts are damaged, replace the complete valve assembly. If the valve is not damaged, lubricate the parts with oil and reassemble the valve.

Note: Ensure the same number of washers are used during valve assembly that were removed during disassembly. The number of washers determines control valve operating pressure.

Assembly**CAUTION**

When the pump is overhauled, always replace all O-rings and support rings in the pump. Failure to replace these parts could result in pump failure.

1

Press a new seal in the pump body using drift 9992997 (1).

9992997

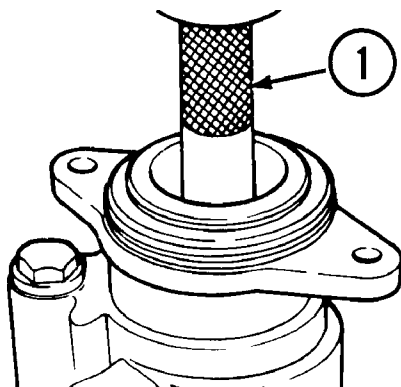

W6000034

2

Place the shaft and bearing in the pump body. Press the bearing in with sleeve 9996075 (1).

9996075

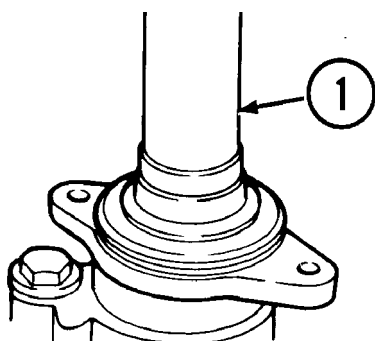

W6000035

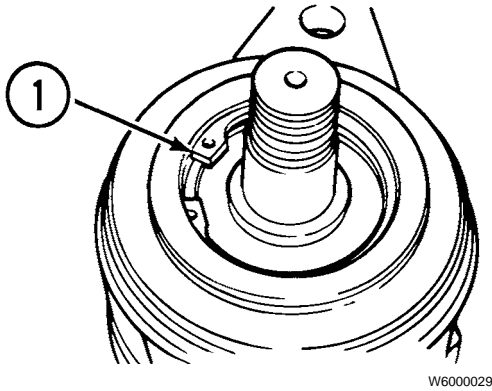

- 3**
Install the snap ring (1). Make sure the snap ring seats fully in the groove.

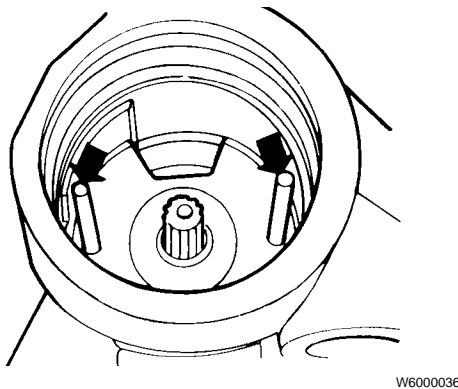

- 4**
Install the two guide pins in the pump body.

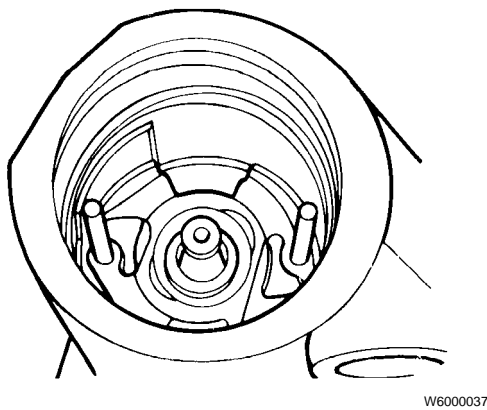

- 5**
Install the inner plate in the pump body with the stamped number and the molded outlet facing toward the cam ring.

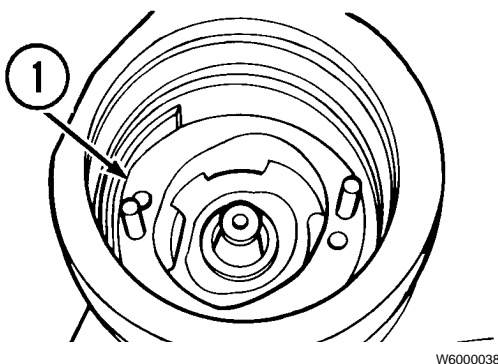

- 6**
Place the cam ring (1) in the body. Ensure the channels in the cam ring align with the channels in the inner plate.

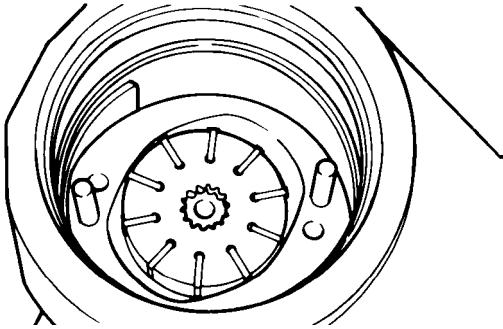

W6000039

7

Install the rotor in the pump body with the chamber for the internal splines facing the drive side. Place the vanes in the rotor with the rounded sides outward toward the cam ring.

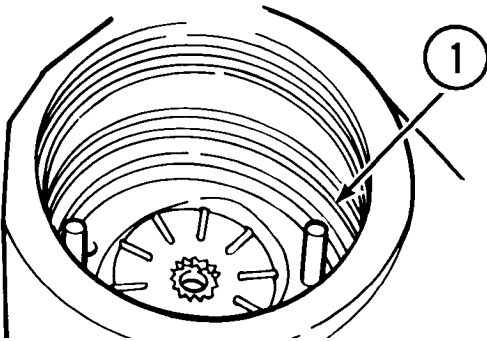

W6000040

8

Install a new O-ring (1) in the pump body.

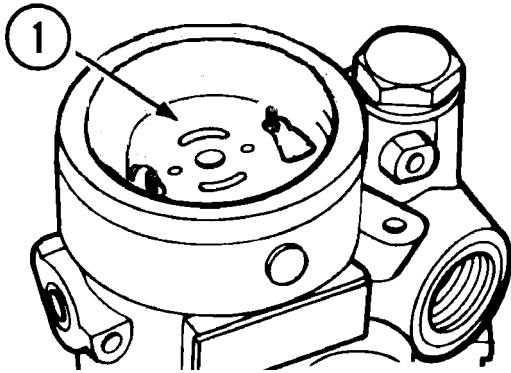

W6000053

9

Install the outer plate (1) in the pump body with the stamped number and the machined surface toward the cam ring. Ensure the guide pins are aligned in the holes.

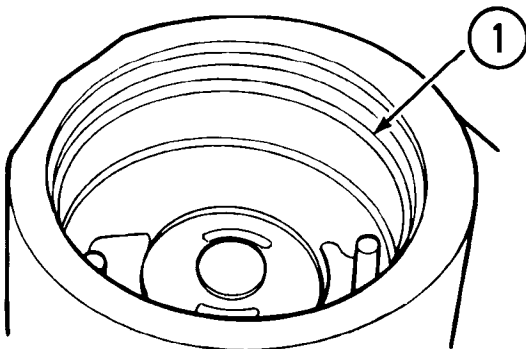

W6000054

10

Install a new O-ring (1) in the pump body.

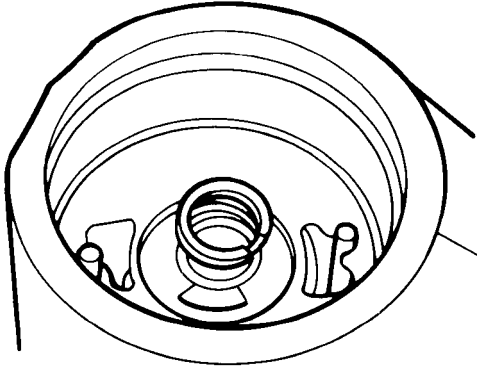

W6000042

11

Place the spring on the outer plate and install the cap. Press down on the cap with pliers and install the lock ring.

12

Install the key in the shaft if it was removed. Heat the drive gear to approximately 100°C (212°F) and install it on the shaft.

13

Install the washer and retaining nut. Torque the nut to 100 Nm (74 ft-lb).

100 Nm
(74 ft-lb)

14

Install a new O-ring on the pump body.

LuK

Disassembly

1
Remove the O-ring or gasket from the pump flange.

2



CAUTION

Possible component damage. Use protective jaw caps on the vise. Failure to do so can cause damage to the pump.

If the pump has a drive gear, clamp the drive gear in a vise with protective jaw caps and remove the drive gear nut.

3

If the pump has a drive gear, place the pump in a vise. Use puller 9995433 (1) and 9995434 (2) to remove the drive gear.

9995433
, 9995434

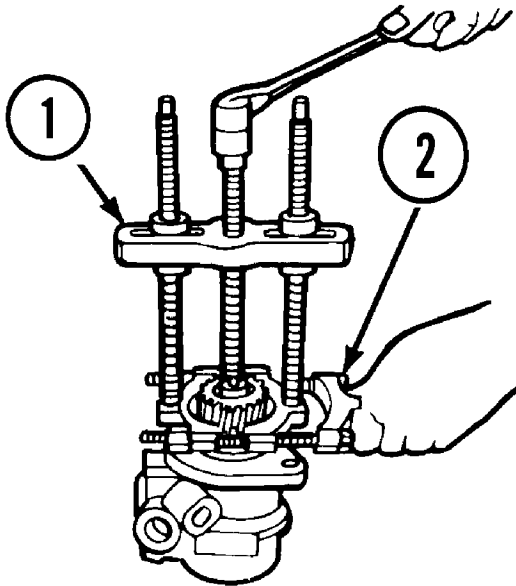

W600007

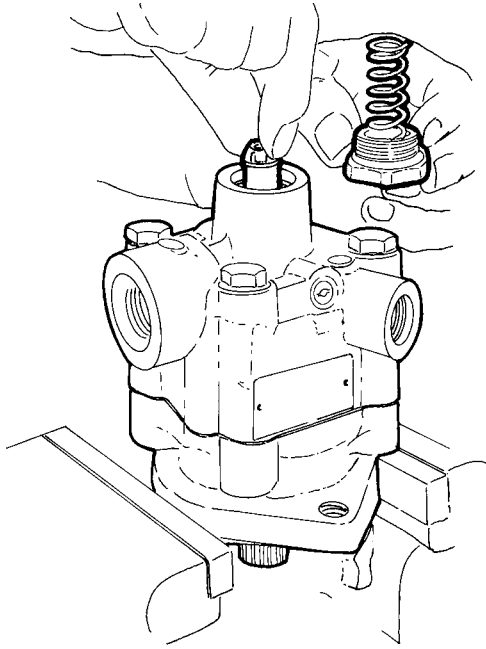

W6000794

4

Remove the plug, spring, and control valve from the control valve port.

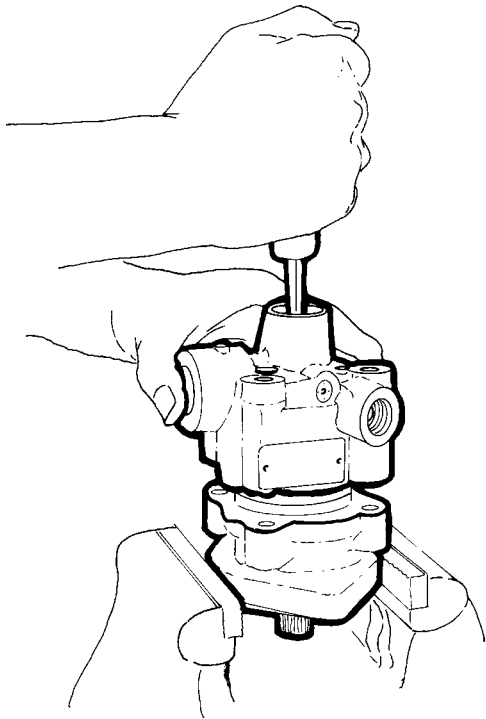

W6000791

5

Remove the four housing bolts. Separate the housing from the flange.

6

Remove the cartridge from the housing. Keep the cartridge together so the valves stay in place.

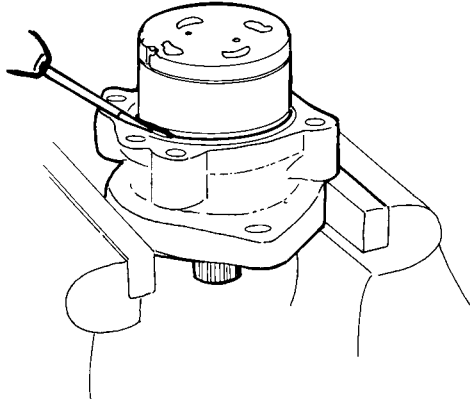

W6000792

7

Remove the large snap ring from the shaft. Tap the shaft out of the flange with a plastic tipped hammer.

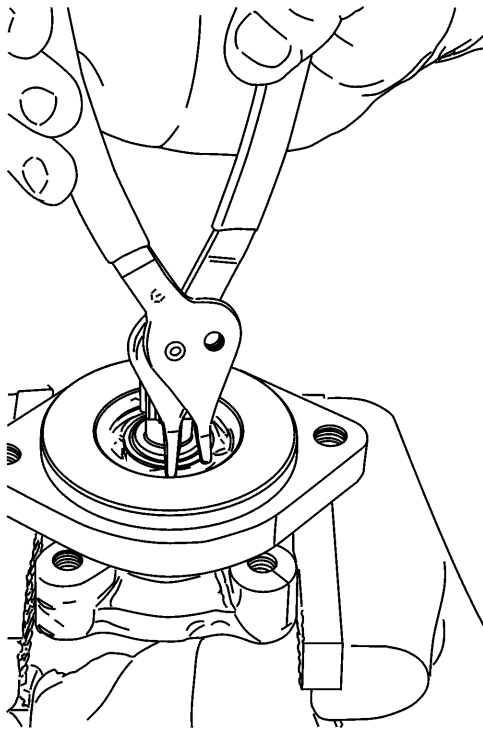

W6001345

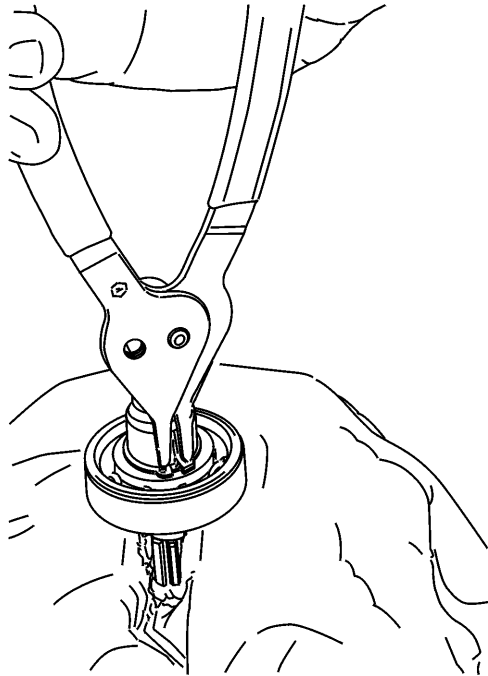

W6001352

8

If the shaft has a bearing, remove the small snap ring which holds the shaft seal. Press the shaft out of the bearing.

9

Remove the shaft seal from the flange.

Cleaning and Inspection

1

Thoroughly clean all parts of the pump.

2

Check the shaft for wear at the seal surface and at the wear surface for the bushing (if bushing type pump). Inspect the splines and threads for damage. Replace the shaft if necessary.

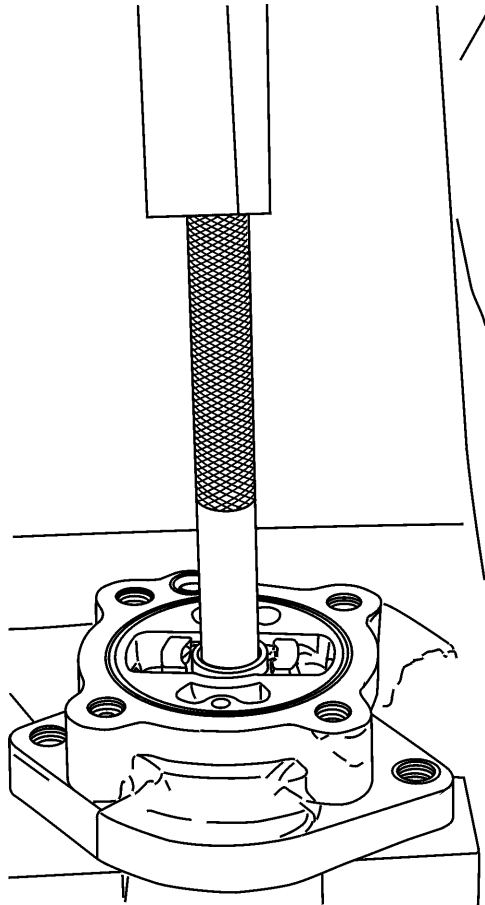

W6001349

3

Check the bushing for wear (small bushing on gear driven pumps, large bushing on spline driven pumps). If damaged, replace the bushing as follows:

- a** Press the bushing out using a suitable drift.
- b** Press a new bushing in flush with the inner flange surface.

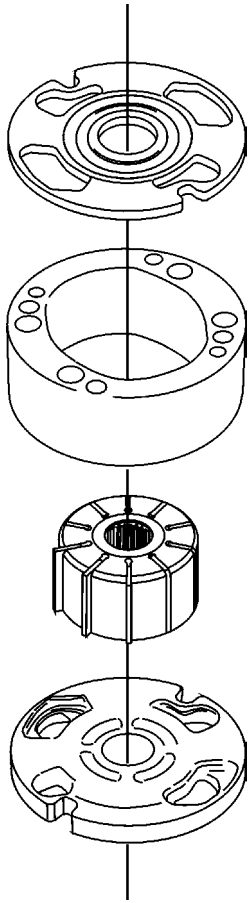

W6001346

4

Separate the parts of the cartridge (wear plates, cam ring, rotor, and vanes).

5

Check the outer and inner plates of the cartridge for wear and scoring. Pay particular attention to the surfaces that ride against the rotor. Check the rotor, cam ring, and vanes for wear. Ensure the vanes fit easily in the rotor. If replacement is necessary, the rotor, vanes, and cam ring must be replaced as a unit.

6

Check that the control valve does not bind in the body. If binding is evident, replace the control valve.

7

If the control valve is to be reused, disassemble the valve using pliers clamped over the hole in the side of the valve.

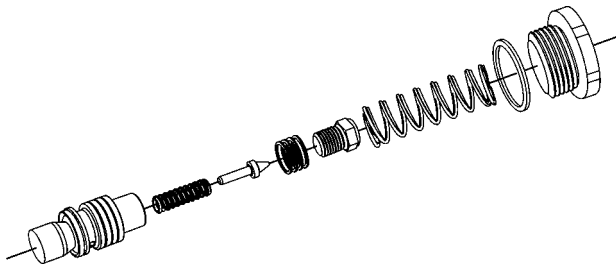

W6001347

8

Clean and inspect the valve components. If any of the valve parts are damaged, replace the complete valve assembly. If the valve is not damaged, lubricate the parts with oil and reassemble the valve.

Note: Ensure the same number of washers are used during valve assembly that were removed during disassembly. The number of washers determines control valve operating pressure.

Assembly

CAUTION

When the pump is overhauled, always replace all O-rings in the pump. Failure to replace these parts could result in pump failure.

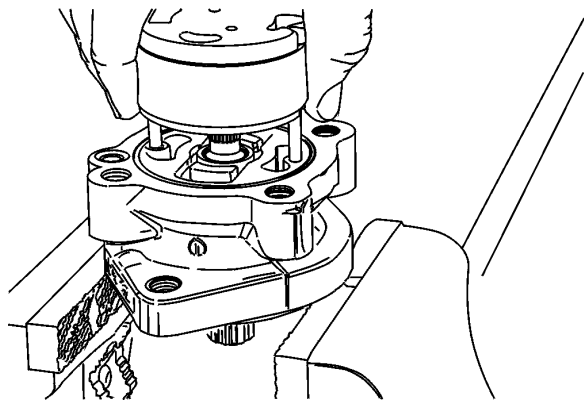

W6001353

1

Assemble the cartridge as follows.

- a** Place the inner wear plate on a flat surface with the side with the stamped numbers and machined surface facing up.
- b** Place the cam ring on the inner wear plate.
- c** Place the rotor in the cam ring.
- d** Install the vanes in the rotor with the rounded and polished edges toward the outside.
- e** Place the outer plate on the cam ring with stamped numbers and machined surface facing the rotor.

2

Grease a new shaft seal and press it into the housing.

3

If bearing type pump, press a new bearing on the shaft and secure it with the small snap ring.

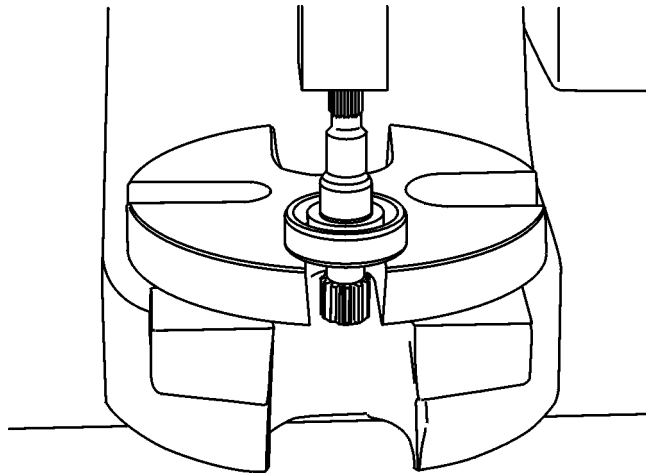

W6001348

4

Install the shaft into the flange. Tap the shaft into the flange using a plastic tipped hammer. Install the large snap ring.

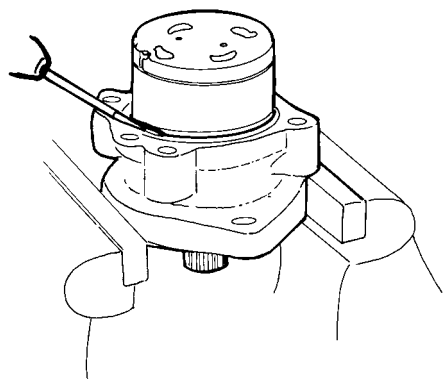

W6000792

- 5**
Install new O-rings on the flange.

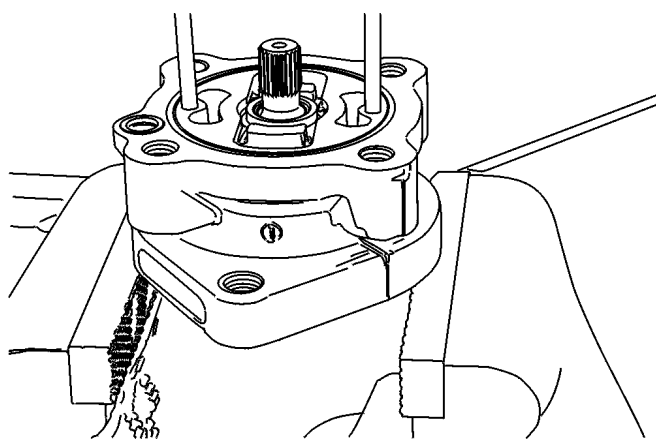

W6001344

- 6**
Insert the guide pins into the holes in the flange.

- 7**
Install the cartridge on the flange. Ensure the thinner end plate is against the flange. Verify proper orientation of the cam ring.

- 8**
Put the housing on the flange. Install and torque the bolts to 45 ± 5 Nm (33 ± 3.7 ft-lb).

45 ± 5 Nm
(33 ± 3.7 ft-lb)

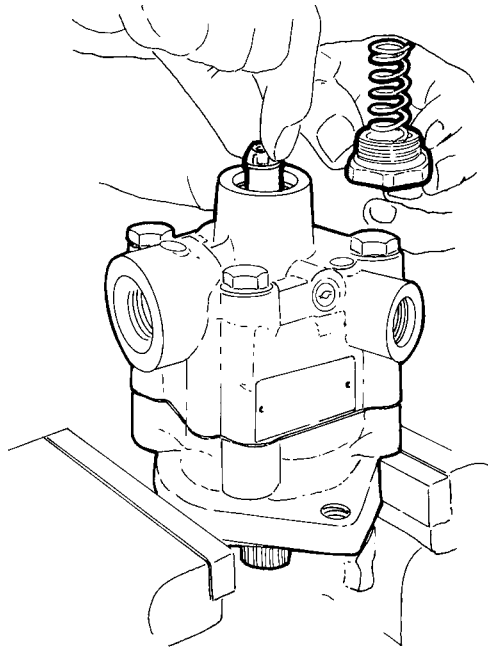

W6000794

9

Install the control valve and its spring.

10

Install a new O-ring on the plug and install and tighten the plug.

11

Install a new O-ring or gasket on the pump flange.

12

If the pump is gear driven, place the wedge key in the shaft. Heat the drive gear to approximately 100°C (212°F) and install it on the shaft.

13

Install the washer (if used) and the nut. Torque the nut to 100 Nm (74 ft-lb).

100 Nm
(74 ft-lb)

6453-02-01-01 Power Steering Pump, Installation

See "General Work Practices" page 17 for important service information before beginning this procedure.

DANGER

Before working on a vehicle, set the parking brakes, place the transmission in neutral, and block the wheels. Failure to do so can result in unexpected vehicle movement and can cause serious personal injury or death.

1
If necessary, transfer the fluid fittings from the pump removed or install new fittings on the pump to be installed. Ensure the fittings are properly oriented.

2
If pump shaft is splined, ensure there is a circlip installed in the drive coupler and the drive coupler is placed on the engine timing gears.

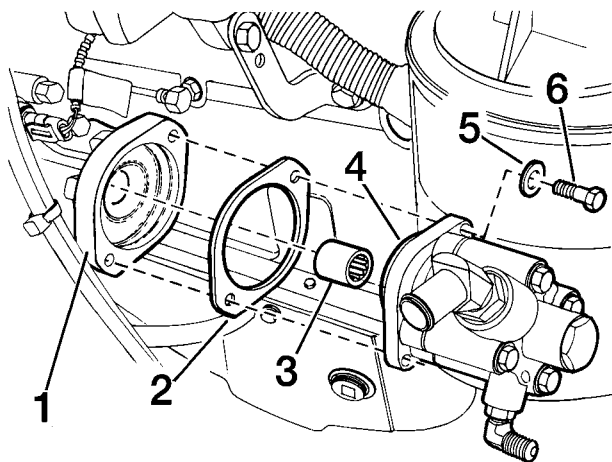

Spline driven pump

- 1 Engine flange
- 2 Gasket
- 3 Drive coupler
- 4 Pump flange
- 5 Washer
- 6 Mounting bolt

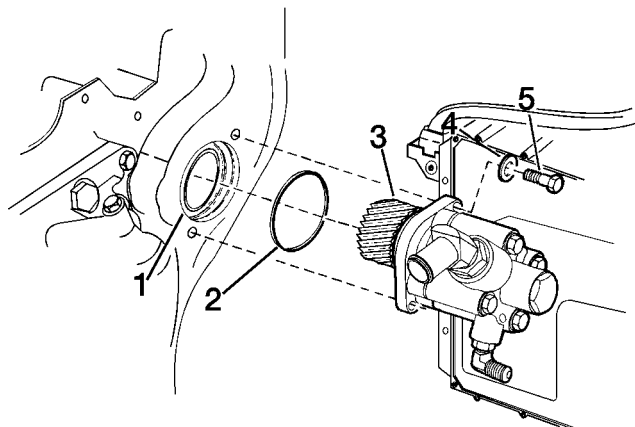

Gear driven pump.

- 1 Mounting hole
- 2 O-ring
- 3 Drive gear
- 4 Pump flange
- 5 Mounting bolt

3

For spline driven pumps, place a gasket on the pump. For gear driven pumps, install an O-ring on the pump.

4

Install the pump on the engine. Torque the mounting bolts to 46 ± 1 Nm (34 ± 1 ft-lb).



CAUTION

Component damage may occur if the cleanliness of the hydraulic system is not maintained. The area around any component to be disconnected/connected should be cleaned prior to disconnecting/connecting. Used hydraulic fluid should never be put into the hydraulic system. Failure to follow these precautions could result in damage to the steering system hydraulic components.

46 ± 1 Nm
(34 ± 1 ft-lb)

5

Connect the two fluid lines to the pump. Using a plastic cable tie, strap the fluid lines together to prevent them from rubbing on the frame.

6

Fill the reservoir with power steering fluid and bleed the system in accordance with the hydraulic system bleeding service procedure. Verify there is no leakage in the system.

Feedback

One of our objectives is that workshop personnel should have access to correct and appropriate service manuals where it concerns fault tracing, repairs and maintenance of Volvo trucks.
In order to maintain the high standards of our literature, your opinions and experience when using this manual would be greatly appreciated.
If you have any comments or suggestions, make a copy of this page, write down your comments and send them to us, either via telefax or mailing directly to the address listed below.

To

Volvo Trucks North America, Inc.
Dept. 516 Service Publications
7825 National Service Road
P.O. Box 26115
Greensboro, NC 27402-6115
USA

Fax (336) 393-3170

From

.....

.....

.....

.....

.....

.....

.....

Comments/proposals

.....

.....

.....

.....

.....

.....

.....

.....

.....

.....

.....

.....

.....

.....

Concerns Service Manual:

Operation Numbers

6453-06-02-01 Hydraulic Pressure, Test	20
6453-06-02-02 Power Steering Pump, Flow Test	22
6459-05-03-01 Power Steering Hydraulic System, Bleeding	24
6453-01-01-01 Power Steering Pump, Removal	26
6453-04-04-01 Power Steering Pump, Overhaul	28
6453-02-01-01 Power Steering Pump, Installation	54

VOLVO

Volvo Trucks North America, Inc.

P.O. Box 26115, Greensboro, NC 27402-6115

Volvo Trucks Canada, Ltd.

5600A Cancross Court, Mississauga, Ontario L5R 3E9

<http://www.volvotrucks.volvo.com>