

LENNOX[®]
HEARTH PRODUCTS



www.nficertified.org

We suggest that our gas hearth products be installed and serviced by professionals who are certified in the U.S. by the National Fireplace Institute[®] (NFI) as NFI Gas Specialists.



Report No. 189122-1050009

INSTALLATION AND OPERATION MANUAL

FREESTANDING VENTED GAS FIRED ROOM HEATERS



Shown with optional gold door and brickaded interior

Model: L30 DVF-2 (Direct-Vent)

RETAIN THIS MANUAL FOR FUTURE REFERENCE

P/N 775,029M Rev. B, 8/04

This appliance may be installed in an aftermarket permanently located, manufactured (mobile) home, where not prohibited by local codes

WARNING: IF THE INFORMATION IN THIS MANUAL IS NOT FOLLOWED EXACTLY, A FIRE OR EXPLOSION MAY RESULT CAUSING PROPERTY DAMAGE, PERSONAL INJURY OR LOSS OF LIFE.

FOR YOUR SAFETY: Do not store or use gasoline or other flammable vapors or liquids in the vicinity of this or any other appliance.

FOR YOUR SAFETY: What to do if you smell gas:

- DO NOT light any appliance.
- DO NOT touch any electrical switches.
- Do not use any phone in your building.
- Immediately call your gas supplier from a neighbor's phone. Follow your gas suppliers instructions.
- If your gas supplier cannot be reached, call the fire department.

Installation and service must be performed by a qualified installer, service agency or the gas supplier.

AVERTISSEMENT: ASSUREZ-VOUS DE BIEN SUIVRE LES INSTRUCTIONS DONNÉ DANS CETTE NOTICE POUR RÉDUIRE AU MINIMUM LE RISQUE D'INCENDIE OU POUR ÉVITER TOUT DOMMAGE MATÉRIEL, TOUTE BLESSURE OU LA MORT.

POUR VOTRE SECURITE: Ne pas entreposer ni utiliser d'essence ni d'autre vapeurs ou liquides inflammables dans le voisinage de cet appareil ou de tout autre appareil.

POUR VOTRE SÉCURITÉ: Que faire si vous sentez une odeur de gaz:

- Ne pas tenter d'allumer d'appareil.
- Ne touchez à aucun interrupteur. Ne pas vous servir des téléphones se trouvant dans le bâtiment où vous vous trouvez.
- Évacuez la pièce, le bâtiment ou la zone.
- Appelez immédiatement votre fournisseur de gaz depuis un voisin. Suivez les instructions du fournisseur.
- Si vous ne pouvez rejoindre le fournisseur de gaz, appelez le service des incendies.

L'installation et service doit être exécuté par un qualifié installateur, agence de service ou le fournisseur de gaz.

IMPORTANT WARNINGS / CAUTIONS

CAUTION: READ THIS MANUAL THOROUGHLY BEFORE STARTING INSTALLATION. FOR YOUR SAFETY, FOLLOW THE INSTALLATION, OPERATION AND MAINTENANCE INSTRUCTIONS EXACTLY WITHOUT DEVIATION. FAILURE TO FOLLOW THESE INSTRUCTIONS MAY RESULT IN A POSSIBLE FIRE HAZARD AND MAY VOID THE WARRANTY. IF THIS APPLIANCE IS NOT PROPERLY INSTALLED, A HOUSE FIRE MAY RESULT. CONTACT LOCAL BUILDING OR FIRE OFFICIALS ABOUT RESTRICTIONS AND INSTALLATION INSPECTION IN YOUR AREA.

1. **WARNING: IMPROPER ASSEMBLY, INSTALLATION, ADJUSTMENT, ALTERATION, SERVICE OR MAINTENANCE CAN CAUSE INJURY AND / OR PROPERTY DAMAGE. INSTALLATION AND SERVICE MUST BE PERFORMED BY A QUALIFIED INSTALLER, SERVICE AGENCY OR THE GAS SUPPLIER. EXCEPT WHEN COMPLYING WITH LOCAL CODES, ANY DEVIATION FROM THE INSTALLATION AND/OR OPERATING INSTRUCTIONS CONTAINED IN THIS MANUAL WILL VOID THE APPLIANCE WARRANTY AND MAY BE HAZARDOUS.**
2. **DUE TO HIGH TEMPERATURES, THIS APPLIANCE SHOULD BE LOCATED OUT OF TRAFFIC AND AWAY FROM FURNITURE, DRAPERIES AND NOT IN WINDY OR DRAFTY AREAS.**
3. **THE APPLIANCE MUST NOT BE CONNECTED TO A CHIMNEY FLUE SERVING A SEPARATE SOLID-FUEL BURNING APPLIANCE.**
4. **THIS APPLIANCE IS EQUIPPED WITH 3 RELIEF DOORS (ONE BEHIND THE BACK PANEL, AND ONE ON EACH SIDE, BEHIND SIDE PANELS) IN CASE OF DELAYED IGNITION BLOW BACK. IF ONE OR MORE RELIEF DOORS OPEN, INSPECT FOR GASKET DAMAGE. IF NECESSARY, REPLACE WITH FACTORY SUPPLIED GASKET ONLY. CONFIRM RELIEF DOORS ARE CLOSED AND PROPERLY SEATED.**
5. **CAUTION: HOT WHILE IN OPERATION. AN APPLIANCE HOT ENOUGH TO WARM YOUR HOME CAN SEVERELY BURN ANYONE TOUCHING IT. KEEP CHILDREN, CLOTHING AND FURNITURE AWAY. CONTACT MAY CAUSE SKIN BURNS. DO NOT LET CHILDREN TOUCH THE APPLIANCE. TRAIN THEM TO STAY A SAFE DISTANCE FROM THE UNIT.**
6. **DO NOT PLACE CLOTHING OR OTHER FLAMMABLE MATERIAL ON OR NEAR THE GAS APPLIANCE. THE MINIMUM CLEARANCES MUST BE MAINTAINED FOR ALL COMBUSTIBLE SURFACES AND MATERIALS INCLUDING; FURNITURE, CARPET, DRAPES, CLOTHING, WOOD, PAPERS, ETC.**
7. **NEVER SEAL THE OPENING AT THE REAR OF THE STOVE.**
8. **DO NOT CONNECT 110-12 VAC (RESIDENTIAL LINE VOLTAGE) TO THE GAS CONTROL VALVE OR CONTROL WIRING SYSTEM OF THE UNIT.**
9. **ANY SAFETY SCREEN OR GUARD REMOVED FOR SERVICING MUST BE REPLACED PRIOR TO OPERATING THE APPLIANCE.**
10. **WARNING: USE ONLY THE GLASS DOOR CERTIFIED WITH THIS APPLIANCE. EXERCISE CAUTION TO PROTECT GLASS FROM IMPACT. DO NOT OPERATE THE APPLIANCE WITH BROKEN GLASS OR USE SUBSTITUTE MATERIALS.**
11. **DO NOT USE THIS APPLIANCE IF ANY PART HAS BEEN UNDER WATER. IMMEDIATELY CALL A QUALIFIED SERVICE TECHNICIAN TO INSPECT THE APPLIANCE AND REPLACE ANY PART OF THE CONTROL SYSTEM AND GAS CONTROL WHICH HAS BEEN UNDER WATER.**
12. **DO NOT BURN WOOD OR OTHER MATERIAL IN THIS HEATER.**
13. **WARNING: THE APPLIANCE AREA MUST BE KEPT CLEAR AND FREE FROM COMBUSTIBLE MATERIALS, GASOLINE AND OTHER FLAMMABLE VAPORS AND LIQUIDS.**
14. **DO NOT USE A BLOWER INSERT, HEAT EXCHANGER INSERT OR OTHER ACCESSORY NOT APPROVED FOR USE WITH THIS APPLIANCE.**
15. **THIS APPLIANCE IS NOT FOR USE WITH AIR FILTERS.**
16. **ANY CHANGE TO THIS HEATER OR ITS CONTROLS CAN BE DANGEROUS.**
17. **THE APPLIANCE SHOULD BE INSPECTED AND MAINTAINED AT LEAST ANNUALLY BY A PROFESSIONAL SERVICE PERSON. MORE FREQUENT CLEANING MAY BE REQUIRED DUE TO EXCESSIVE LINT FROM CARPETING, BEDDING MATERIAL, ETC. IT IS IMPERATIVE THAT CONTROL COMPARTMENTS, BURNERS AND CIRCULATING AIR PASSAGEWAYS OF THE APPLIANCE BE KEPT CLEAN.**
18. **THIS APPLIANCE IS ONLY FOR USE WITH THE TYPE OF GAS INDICATED ON THE RATING LABEL (LOCATED INSIDE CONTROL PANEL). THIS APPLIANCE IS NOT CONVERTIBLE FOR USE WITH OTHER FUEL UNLESS A CERTIFIED KIT IS USED.**
19. **CAUTION: UNDER NO CIRCUMSTANCES SHOULD THESE APPLIANCES BE VENTED TO OTHER ROOMS OR BUILDINGS. THESE APPLIANCES MUST ONLY BE VENTED TO THE OUTSIDE. VENT TERMINATIONS SHALL NOT BE RECESSED INTO A WALL OR SIDING.**
20. **WARNING: THIS APPLIANCE MUST BE PROPERLY CONNECTED TO A VENTING SYSTEM. OPERATION OF THIS GAS APPLIANCE WHEN NOT CONNECTED TO A PROPERLY INSTALLED AND MAINTAINED VENTING SYSTEM CAN RESULT IN CARBON MONOXIDE (CO) POISONING AND POSSIBLE DEATH.**
21. **WARNING: DO NOT MODIFY THE VENTING SYSTEM, APPLIANCE, OR CONTROLS IN ANY WAY. BE ADVISED, ANY MODIFICATION CAN BE DANGEROUS. PROVISIONS MUST BE MADE TO ENSURE THE INTAKE AND EXHAUST PASSAGES OF THE VENT TERMINATION CAP REMAIN UNRESTRICTED.**
22. **IMPORTANT: DO NOT EXCEED THE MAXIMUM HORIZONTAL RUN ALLOWED.**
23. **SAVE THESE INSTRUCTIONS.**

TABLE OF CONTENTS

Important Warnings	2
Testing / Listing, Using this Manual	3
Planning Your Installation	4-6
Manufactured (Mobile) Home Installation.....	6
Installation	7-15
Care and Operation	16-17
Propane Conversion	18-19
Maintenance.....	20-21
Wiring Diagrams	22
Troubleshooting	23
Replacement Parts	24
Optional Accessories	25
Specifications	26
Safety / Listing Label	27
Ownership Record and Service Log.....	28

TESTING / LISTING

This appliance is tested and certified as safe for residential use by an internationally recognized testing and certification agency. The safety tests are conducted in accordance with American National Standards Institute (ANSI) requirements. The Lennox Elite series appliances are tested, certified, and listed by the CSA, AGA, CGA to ANSI Z21.88 - 1998 Vented Gas Fireplace Heaters and CSA 2.33 - M98 Vented Gas Fireplace Heaters.

APPROVED VENT BRANDS:

This appliance is listed for installation with Security Secure Vent chimney or Simpson Dura Vent brand chimney only. Other brands may not be used. See pages 7, 8 and 9.

CONGRATULATIONS ON THE PURCHASE OF YOUR NEW GAS APPLIANCE MANUFACTURED BY LENNOX HEARTH PRODUCTS.

When you purchased your new gas fired heater, you joined the ranks of thousands of concerned individuals whose answer to their home heating needs reflects their concern for aesthetics, efficiency and our environment. We extend our continued support to help you achieve the maximum benefit and enjoyment available from your new gas fired heater.

It is our goal at Lennox Hearth Products to provide you, our valued customer, with an appliance that will ensure you years of trouble free warmth and pleasure.

Thank you for selecting a Lennox Hearth Products gas fired heater as the answer to your home heating needs.

Sincerely,
All of us at Lennox Hearth Products

PACKAGING LIST

This appliance is packaged with an accessory package, which contains the following:

- One - Installation and operation instructions manual.
- One - Warranty.
- One - Log set and embers.
- One - LP conversion kit.
- One - Vent restrictor ring.
- One - 9 ft. electrical power cord.

USING THIS MANUAL

Please read and carefully follow all of the instructions found in this manual. Please pay special attention to the safety instructions provided in this manual. Following the Homeowner's Care and Operation Instructions included here will assure that you have many years of dependable and enjoyable service from your appliance.

PLANNING YOUR INSTALLATION

LOCAL AND NATIONAL CODE REQUIREMENTS

The installation of these appliances must conform with local codes or, in the absence of local codes, with the National Fuel Gas Code, (for USA) NFPA 54 / ANSI Z223.1-latest edition.

Air Circulation Blower: The blower electrical power cord must be electrically grounded per local codes or per electrical codes:

In USA, NEC, ANSI / NFPA 70-Latest Edition.

In Canada, CSA C22.1

WARNINGS

ELECTRICAL GROUNDING INSTRUCTIONS. THIS APPLIANCE IS EQUIPPED WITH A THREE-PRONG (GROUNDING) PLUG FOR YOUR PROTECTION AGAINST SHOCK HAZARD AND SHOULD BE PLUGGED DIRECTLY INTO A PROPERLY GROUNDED THREE-PRONG RECEPTACLE. DO NOT CUT OR REMOVE THE GROUNDING PRONG FROM THIS PLUG.

WARNING: TO AVOID ELECTRICAL SHOCK, ALWAYS ENSURE THAT THE POWER CORD IS UNPLUGGED (I.E., THERE IS NO ELECTRICAL POWER TO THE CIRCULATION BLOWER) BEFORE HANDLING THE CIRCULATION BLOWER OR PERFORMING ANY WORK ON THE APPLIANCE.

High Altitude: Gas inputs shown are for elevations up to 4500 feet. For elevations above 4500 feet, contact your gas supplier or qualified service technician regarding the necessary deration of appliance (deration: replacing burner orifice with a smaller one to reduce input). Ratings must be reduced at the rate of 4 percent for each 1,000 feet above sea level. Refer to (for USA) NFPA 54 / ANSI Z223.1-latest edition for orifice re-sizing.

TOOL / EQUIPMENT LIST

The following tools and equipment are recommended for completing the partial assembly required when the appliance is installed:

- $\frac{1}{4}$ " wrench.
- $\frac{1}{4}$ ", $\frac{5}{16}$ " nut drivers.
- Pipe wrench.
- Phillips head screw driver.
- Flat head screw driver.
- Pipe sealant compound.
- Leak test fluid.
- Leak test fluid "U" tube manometer or pressure gauge (0 - 16" (inches water column) H₂O scale).

GAS PRESSURE (WC = Water Column)

Minimum inlet gas supply pressure for the purpose of input adjustment:

Natural Gas - 4.5" WC min. – 7.0" WC max.

Propane (LP) - 11" WC min - 13.0" WC max.

Manifold gas supply pressure:

	LOW		HIGH
Natural Gas -	1.8" +/- .3" WC	(to)	3.5" +/- .3" WC
	25,000 BTU / hr		37,000 BTU / hr
Propane (LP)	6.6" +/- .3" WC	(to)	10" +/- .3" WC
	28,000 BTU / hr		35,000 BTU / hr

Note: " WC = Inches Water Column

PRESSURE TAPS

Gas Inlet Pressure Tap - Located on bottom left of gas valve.

Gas Outlet (manifold) pressure tap - Located on bottom right of gas valve.

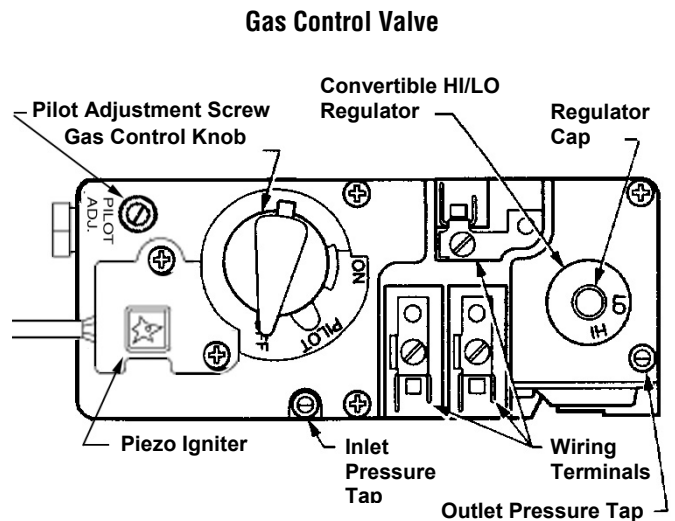

Pressure Testing: See *Pressure Testing* on page 11.

⚠ IMPORTANT

Appliance gas valves can be damaged if subjected to more than 1/2 psig (3.48 kPa) pressure. Therefore, when pressure testing the gas supply piping system in this pressure range, the appliance gas valve must be disconnected and isolated.

PLANNING YOUR INSTALLATION

QUESTIONS TO ASK THE LOCAL BUILDING OFFICIAL

Correct installation is critical and imperative for reducing fire hazards and perilous conditions that can arise when gas appliances function improperly. The appliance must be installed per manufacturers' instructions.

Gas appliance equipment and installations must conform to appropriate local codes and applicable state and federal requirements. Familiarity with these requirements before installation is essential. Important considerations to discuss with local building officials include:

1. Applicable codes (i.e. Uniform Mechanical Code, State or Regional Gas Codes, National Fuel Gas Code)?
2. Local amendments?
3. Recognized testing lab: CSA / AGA.
4. Is a permit required - cost?
5. In some states or municipalities, a licensed gas fitter or plumber may be required to install this appliance. Check with your local building official for requirements in your area (i.e. Is a license required for installation of gas supply line)?
6. Maximum amount of gas pipe without a pressure test - type of test required?
7. Are below grade penetrations of the gas line allowed?
8. Is concealed gas piping allowed?
9. Specific requirements of concealed fittings?
10. Is rigid pipe to appliance required?
11. Allowed piping materials?
12. Shut-off valve required within 4 feet of the firebox?
13. May the shut-off valve be concealed?
14. Rooms where the installation is not allowed?

In the absence of local codes, installation should conform to the National Fuel Gas Code, also known as ANSI Z223.1-NFPA 54.

PLANNING YOUR INSTALLATION

CLEARANCES TO COMBUSTIBLE MATERIALS

These appliances can be installed in most residential room configurations, parallel to a rear or adjacent wall, or in an alcove that allows for the minimum clearances to combustible surfaces. Your local building inspector should review your plans prior to installation.

When installing this appliance, provide adequate clearances around air openings and adequate clearances for purposes of servicing and proper operation.

As determined through the safety certification of this unit, a minimum clearance to combustible materials must be maintained around specific areas of the gas appliance. (Refer to Figures 1 through 3)

The clearances listed here are minimum distances and only apply in the configuration shown. Do not use clearances from one installation configuration with clearances from another to obtain closer clearances.

Top of appliance (min.)	36" (inches)
<i>This includes any projections such as shelves, window sills, mantels, etc. above the appliance.</i>	
Back Wall	2" (inches)
Side Wall	12" (inches)
Corner (45° angle)	4" (inches)
stove corners to wall	
Ceiling Minimum	65" (inches) from floor
Alcove Min. Height	65" (inches) from floor
Alcove Min. Width	53 7/8" (inches)
Alcove Max. Depth	24" (inches) from unit face.
<i>The stove can not be placed deeper into an alcove than 24" from the stove face to alcove opening.</i>	
Floor	0 inches

MANUFACTURED (MOBILE) HOME REQUIREMENTS

Model L30 DVF-2 may be installed in an aftermarket permanently located, manufactured home, where not prohibited by local codes. When installed in Manufactured Housing the following supplemental requirements must be met:

- The appliance must be secured to the floor. Use the (3) 1/4"-20x2 3/4" lag bolts (which secured appliance pedestal base to the wooden pallet) for securing appliance to the manufactured home floor.
- The appliance must be grounded to the chassis of the manufactured home. Use a No. 8 or heavier copper wire at least 18" in length.

IMPORTANT NOTES:

The structural integrity of the manufactured home floor, walls, ceiling and roof must be maintained.

A manufactured (mobile) home installation must conform with the Manufactured Home Construction and Safety Standard, Title 24 CFR, Part 3280, or, when such a standard is not applicable, the Standard for Manufactured Home Installations, ANSI / NCSBCS A225.1, or standard for Gas equipped Recreational Vehicles and Mobile Housing, CSA Z240.4.

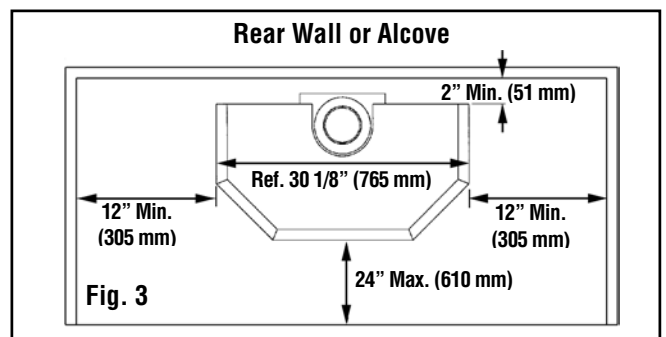
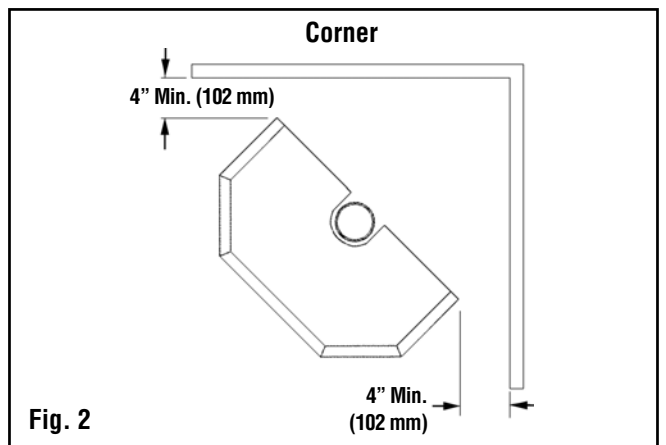
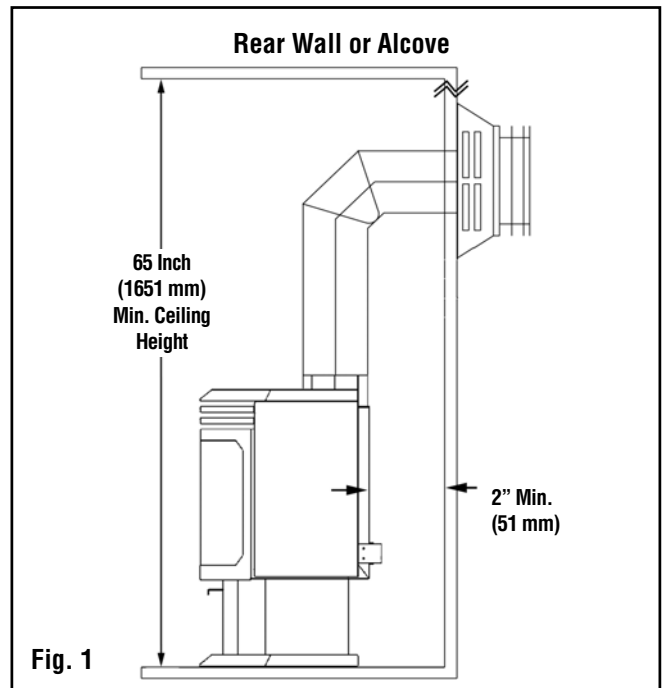

FLOOR PROTECTION

When installed directly on carpeting, tile or other combustible material other than wood flooring, the appliance shall be installed on a metal or wood panel extending the full width and depth of the appliance (♦ see notes below).

♦ Notes:

- 1) Ceramic tile is non-combustible and does not require a wood or metal panel under the appliance.
- 2) Models with a pedestal base where base dimensions exceed width and depth of stove body, qualify as the floor protection

INSTALLATION

This appliance is designed to be vented with a 4" x 6 5/8" direct-vent pipe. Each direct-vent appliance must use its own separate vent system

VERTICAL TERMINATION WITH NO OFFSETS

Min. Vertical Pipe Length: 5 feet
 Max. Vertical Pipe Length: 25 feet

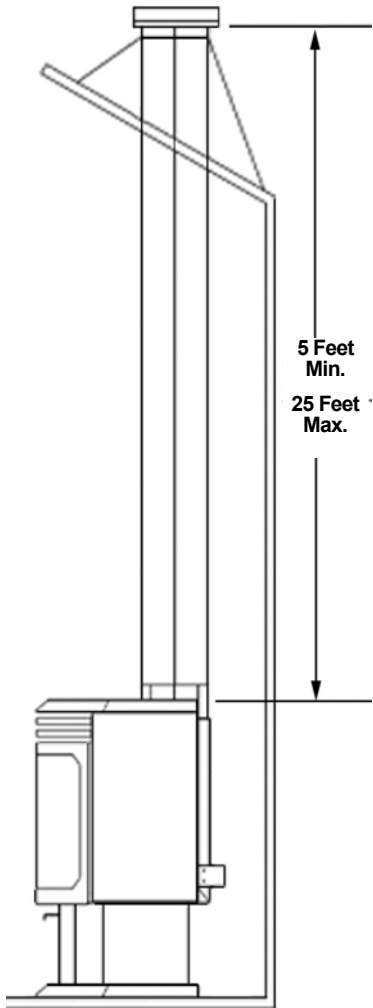

VERTICAL TERMINATION WITH 2 OFFSETS

Min. Vertical Pipe From Appliance to first offset: 2 feet (*see note).
 Min. Total Vertical Pipe Length: 5 feet
 Max. Total Vertical Pipe Length: 25 feet

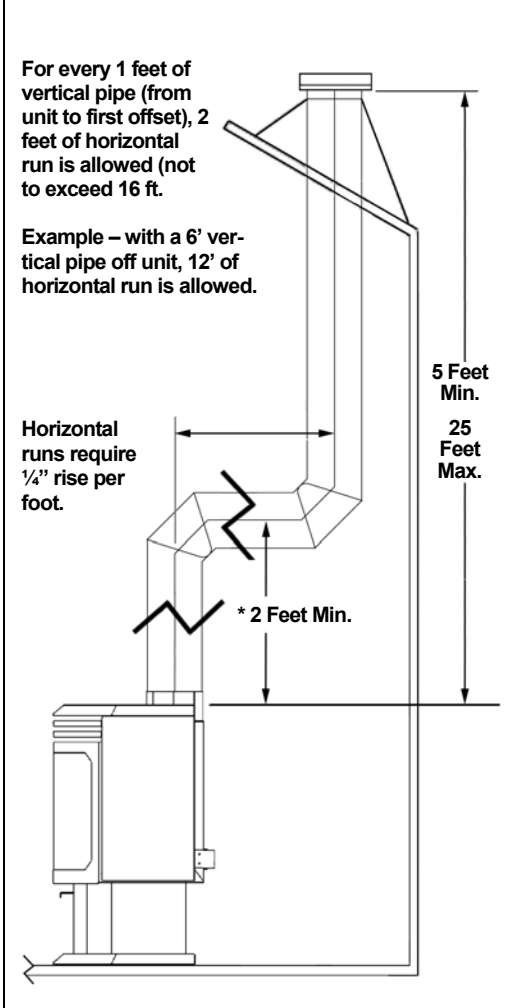

HORIZONTAL TERMINATION WITH 1 OFFSET

Min. Vertical Pipe From Appliance to offset: 2 feet (*see note).
 Max. Vertical Pipe Length: 25 feet

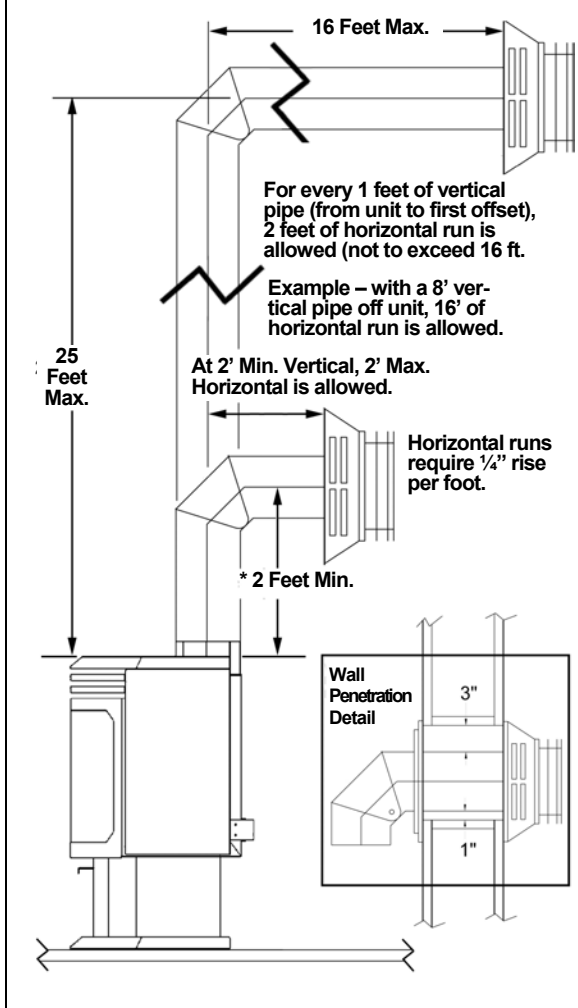

Maximum total offsets allowed: Not to exceed 180 degrees.

Maximum allowable horizontal pipe run is 16 feet.

With 2 feet of vertical pipe installed from the appliance (see note), a 2 foot maximum horizontal run allowed. For installations with more than 2 feet of vertical pipe, calculate allowable horizontal run as indicated in applicable illustration above.*

See page 10 for *Vent Termination Requirements*.

Also see pipe manufacturers instructions for additional vent installation requirements.

Horizontal vent clearances: 3" minimum top 1" minimum on bottom and sidewalls.

Vertical vent clearances: 1" minimum.

Install vent support brackets every 4 feet of vertical pipe unless otherwise specified by vent manufacturer.

** Note: If using Propane Gas (LP), it may be necessary to install (as a minimum) 3 feet of vertical pipe from the appliance prior to an offset to ensure optimum product performance. This may be necessary due to variations in vent configuration and other numerous factors which affect exhaust flow and air delivery such as BTU value, ambient temperature, wind conditions, altitude, etc.*

INSTALLATION

VENT RESTRICTOR RING INSTALLATION

Recommended Restrictor Ring Placement For Optimum Stove Performance

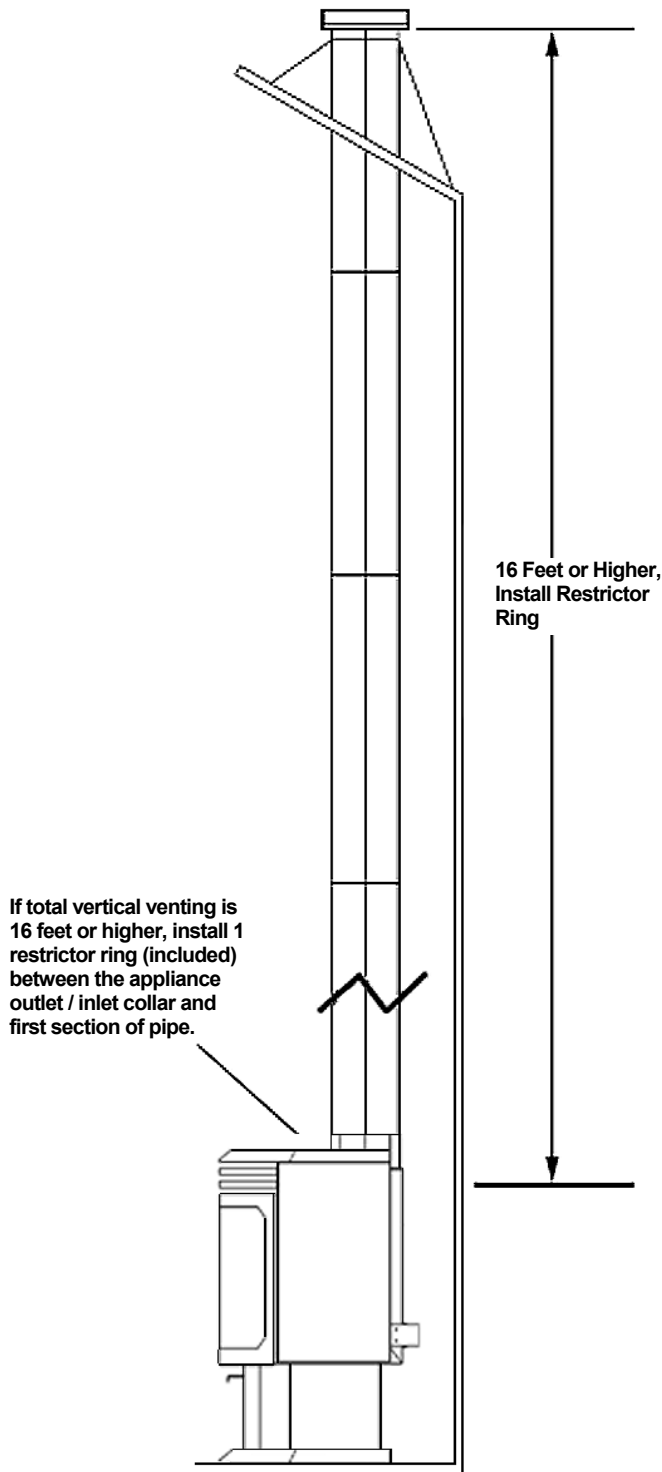

Guideline for Installing Flue Restrictor Ring in Co-Axial Direct-Vent Pipe

If the total vertical venting is 16 feet or higher, installation of 1 restrictor ring is recommended to improve the performance and flame aesthetics of the appliance. Install the restrictor ring between the appliance outlet / inlet collar and the first section of pipe. Depending upon the vent configuration and other variables, it may be necessary to adjust the quantity and position of the restrictor ring(s) to ensure proper operation of the appliance. **Be advised, product performance can be affected due to numerous factors which affect exhaust flow and air delivery, such as – gas BTU value, vent configuration, ambient temperature, altitude, etc.**

Symptoms for Lack of Combustion Air

Remove restrictor ring(s) to increase combustion air delivery if the following symptoms are present (first confirm input is correct, primary air shutter is properly adjusted, venting system connections are secure and not blocked):

- ◆ Flame appears yellow with black tips.
- ◆ Floating Flames (lazy, ill-defined, quiet, may roll).
- ◆ Sooting.
- ◆ Pilot becomes yellow and appliance shuts down.

Symptoms - Excessive Combustion Air

Install one or more restrictor rings to reduce combustion air delivery if the following symptoms are present:

- ◆ Low Flame.
- ◆ Pilot pulls and appliance shuts down.
- ◆ Pilot flame ghosts

INSTALLATION See Pipe Manufacturers Instructions For Installation Of Venting Components & Clearances.

DIRECT VENT SYSTEM COMPONENTS – Model L30 DVF-2

The following Direct-Vent system components may be safely used with this appliance.

Model #	Brand: SECURITY / Description	Model #	Brand: SIMPSON DURA-VENT / Description
SV 0 SHK	Standard Horizontal Term. Kit (90° Black Elbow, Firestop (2), Horizontal Square Term. Cap)	970	Basic Horizontal Term. Kit (90° Black Elbow, Wall Thimble Cover, Horizontal Square Term. Cap)
SV 0 HK	Horizontal Term. Kit (90° Black Elbow, Firestop (2), Horizontal Term. Cap, adj. Black length 1-1/2 – 6")	971	Horizontal Term. Kit A (90° Black Elbow, Wall Thimble Cover, Horizontal Square Term. Cap, adj. 24" black pipe, 11-14 5/8" adj. Black pipe)
SV 0 FK	Vertical Flat Roof Term. Kit (w/flashing, storm collar, vertical Term. Cap)	973	Vertical Termination Kit
SV 0 FAK	Vertical pitched Roof Kit, 1/12-7/12 (with adjustable roof flashing, storm collar, vertical termination cap)	978	Vertical Pitched Roof Kit, 0/12–6/12 (with adjustable flashing, storm collar, low profile term. Cap)
SV 0 FBK	Vertical pitched Roof Kit, 8/12-12/12 (with adjustable roof flashing, storm collar, vertical termination cap)	N/A	N/A
SV 0 L6	6" Pipe Length (Galvalume)		6" Pipe Length (Galvalume)
SV 0 LB6	6" Pipe Length (Black)	908B	6" Pipe Length (Black)
SV 0	9" Pipe Length (Black)	907B	9" Pipe Length (Black)
SV 0 L12	12" Pipe Length (Galvalume)	906	12" Pipe Length (Galvanized)
SV 0 LB12	12" Pipe Length (Black)	906B	12" Pipe Length (Black)
SV 0 L24	24" Pipe Length (Galvalume)	904	24" Pipe Length (Galvanized)
SV 0 LB24	24" Pipe Length (Black)	904B	24" Pipe Length (Black)
SV 0 L36	36" Pipe Length (Galvalume)	903	36" Pipe Length (Galvanized)
SV 0 LB36	36" Pipe Length (Black)	903B	36" Pipe Length (Black)
SV 0 L48	48" Pipe Length (Galvalume)	902	48" Pipe Length (Galvanized)
SV 0 LB48	48" Pipe Length (Black)	902B	48" Pipe Length (Black)
N/A	N/A	911B	11"-14" Adj. Pipe Length (Black)
SV 0 LA	1 1/2- 6" Adj. Pipe Length	N/A	N/A
SV 0 LBA	1 1/2- 6" Adj. Black Pipe Length	N/A	N/A
SV 0 E45	45 Elbow (Galvalume)	945	45 Elbow (Galvanized)
SV 0 EB45	45 Elbow (Black)	945B	45 Elbow (Black)
SV 0 E90	90 Elbow (Galvalume Swivel)	990G	90 Elbow (Galvanized Swivel)
SV 0 EB90	90 Elbow (Black Swivel)	990BG	90 Elbow (Black Swivel)
SV 0	90 Elbow (Galvalume)	990	90 Elbow (Galvanized)
SV 0	90 Elbow (Black)	990B	90 Elbow (Black)
SV 0 CHC	⊕Horizontal Standard Term. Cap	984	⊕Horizontal Standard Term. Cap
SV 0 CHCV	⊕Horizontal High Wind Term. Cap	N/a	⊕Horizontal High Wind Term. Cap
SV 0 CPB	• Vertical Termination Cap	983	• Vertical Termination Cap
SV 0 CGV	• Vertical High Wind Cap	991	• Vertical High Wind Cap
SV 0 STC36	⊗Snorkel Termination Cap 36"	981	⊗Snorkel Termination Cap 36"
SV 0 STC14	⊗Snorkel Termination Cap 14"	982	⊗Snorkel Termination Cap 14"
SV 0	Vinyl Shield Protector	950	Vinyl Siding Standoff
SV 0 VS	Round Ceiling Support /Wall Thimble Cover	940	Round Ceiling Support /Wall Thimble Cover
SV 0 CSB	Cathedral Ceiling Support Box, decorative square	941	Cathedral Ceiling Support Box
SV 0 SF	Black Plate, Decorative	N/A	N/A
SV 0	Round Ceiling Support Box/Wall Thimble	942	Round Ceiling Support Box/Wall Thimble
SV 0	Storm Collar	953	Storm Collar
SV 0 RSM	Wall Radiation Shield	N/A	N/A
SV 0 BF	Firestop	N/A	N/A
N/A	N/A	963	Firestop Spacer
SV 0 F	Flashing, Flat Roof (storm collar included)		
SV 0 FA	Flashing, Adjustable roof 1/12-7/12 (storm collar included)	943	Flashing 0/12-6/12
SV 0 FB	Flashing, Adjustable 8/12-12/12 (storm collar included)	943S	Flashing 7/12-12/12
SV 0 BM	Wall Band	988	Wall Strap

⊗ Snorkel Caps: These are elongate vent termination caps, which incorporate the principles of natural draft into a horizontal installation. Two styles are common, 14" and 36" (Cap height). They enhance draft and relieve backpressure by creating natural draft in the snorkel.

⊕ Horizontal Caps: This 13 1/2" square horizontal cap is placed on the outer wall of the dwelling. Not to be within 9" of an air inlet or within 12" of the ground. It requires a minimum 2' rise on the interior pipe.

• Vertical Termination Cap: Low profile and high wind caps can only be used on vertical pipe installations.

INSTALLATION

DIRECT VENT RETROFIT OF EXISTING CHIMNEY SYSTEM - An existing Class-A (wood-burning) Metal Chimney or Masonry Chimney can be converted to a direct vent system. Use one of the following chimney conversion kits listed below. Have the existing chimney system inspected by a professional prior to the conversion. **If using Simpson Dura-Vent brand liner kit, see "IMPORTANT" note at the top of page 9.** The chimney conversion should not be applied to the portion of the vent system that is in the room of the appliance. Use only Co-Axial direct vent pipe (4" inner pipe, 6 5/8" outer pipe as listed on page 9) from the appliance to the retro-connector into converted flue system. Adhere to all specifications shown on pages 6 and 7 regarding clearances to combustibles, vertical and horizontal vent length minimums and maximums, etc. Read all instructions in this manual and provided by vent manufacturer with kit carefully before starting the installation. Failure to follow the instructions may create a fire or other safety hazard, and will void the warranty.

Model #	Brand: SECURITY / Description	Model #	Brand: SIMPSON DURA-VENT / Description
SV4MCK	Masonry Chimney Conversion Kit – Vertical term. Cap, cap adapter, masonry cover, black adapter (to flex), 2 gear clamps	934	Masonry Chimney Conversion Kit
SV4CCK1	Factory Built Chimney Conversion Kit – for 6" I.D., 1" insulation.	931	Factory Built Chimney Conversion Kit A – for 6" I.D.; Only compatible w/specific brands – Contact Vent Manufacturer
SV4CCK2	Factory Built Chimney Conversion Kit – for 7" I.D., 1" insulation; 8" I.D., 1" insulation; 6" I.D., 2" insulation.	932	Factory Built Chimney Conversion Kit B – for 6", 7" & 8" I.D.; Only compatible w/specific brands – Contact Vent Manufacturer
SV4CCK3	Factory Built Chimney Conversion Kit – for 10" I.D., 1" insulation; 7" I.D., 2" insulation; 8" I.D., 2" insulation.	933	Factory Built Chimney Conversion Kit C – for 7" & 8" I.D.; Only compatible w/specific brands – Contact Vent Manufacturer

VERTICAL VENT TERMINATION CLEARANCES

These instructions should be used as a guideline and do not supersede local codes in any way. Install vent according to local codes, these instructions, the current National Fuel Gas Code (ANSI-Z223.1) in the USA or the current standards of CAN/CGA-B149.1 and -B149.2 in Canada.

Terminate multiple vent terminations according to the installation codes listed above.

Terminate single vent caps relative to building components according to the following chart & illustration. The vent/air intake termination clearances above the high side of an angled roof is as shown in the following chart:

Roof Pitch	Feet	Meters
Flat to 6/12	1	0.3
6/12 to 7/12	1.25	0.38
7/12 to 8/12	1.5	0.46
8/12 to 9/12	2	0.61
9/12 to 10/12	2.5	0.76
10/12 to 11/12	3.25	0.99
11/12 to 12/12	4	1.22
12/12 to 14/12	5	1.52
14/12 to 16/12	6	1.83
16/12 to 18/12	7	2.13
18/12 to 20/12	7.5	2.29
20/12 to 21/12	8	2.44

Termination Heights For Vents Above Flat or Sloped Roofs

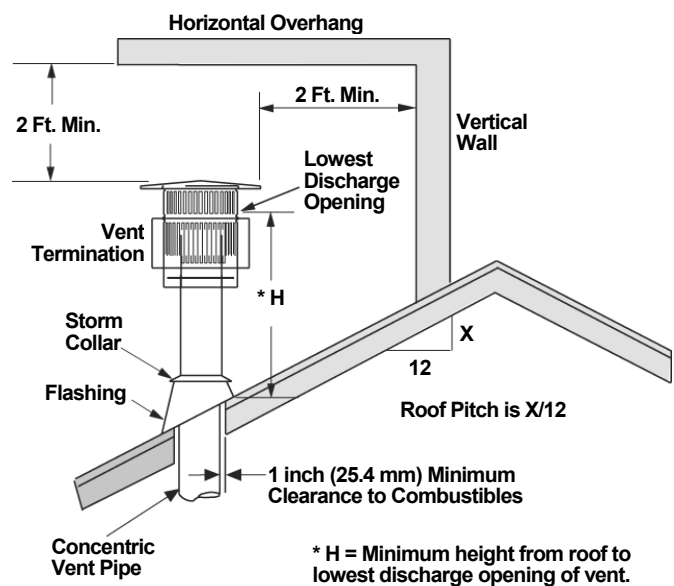

INSTALLATION

HORIZONTAL VENT TERMINATION REQUIREMENTS

The venting terminals should not be recessed into a wall or siding.

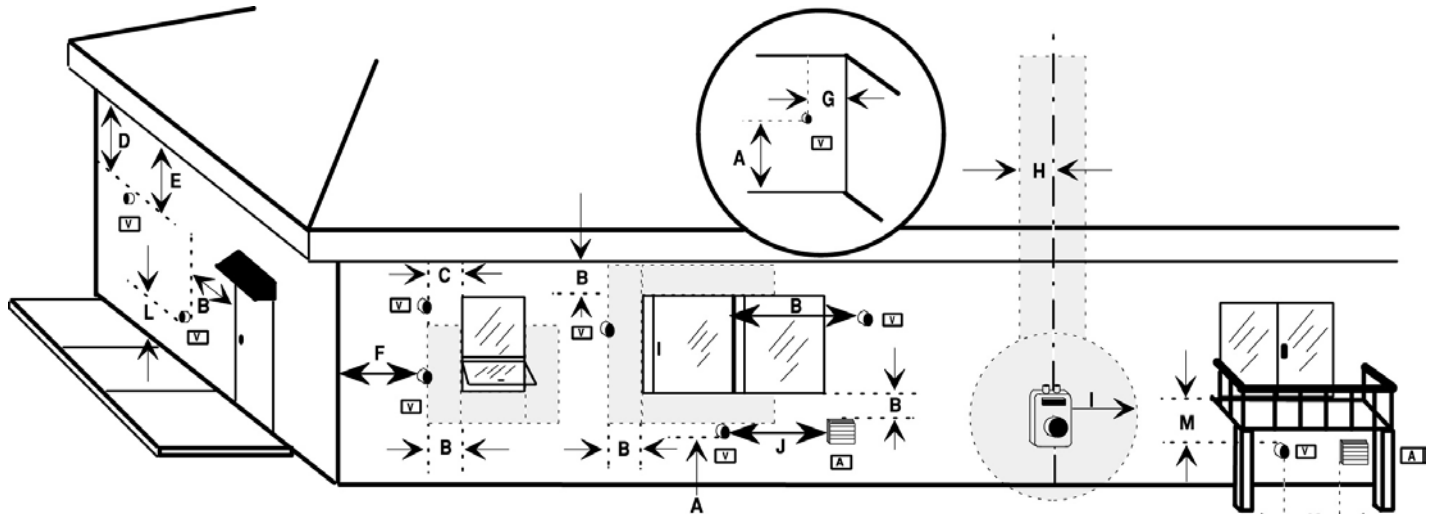

= Area where vent terminal is not permitted.

Vent Terminal

Air Supply Outlet

- A = 2" Clearances above grade, veranda, porch, deck or balcony.
- B = 12" Clearance to window or door that may be opened.
- C = 9" (USA) Clearance to permanently closed window. 12" (CAN)
- D = 24" Vertical clearance to ventilated soffit located above the terminal within a horizontal distance of 2 feet (60 cm) from the center-line of the terminal.
- E = 12" Clearance to unventilated soffit.
- F = 9" Clearance to outside corner.
- G = 6" Clearance to inside corner.
- H = 3 ft. (USA) Not to be installed above a meter/regulator assembly within 3 feet (90 cm) horizontally from the center-line of the regulator.
- I = 3 ft. (USA) Clearance to service regulator vent outlet.
6 ft. (CAN)

- J = 9" (USA) Clearance to non-mechanical air supply inlet to building or the combustion air inlet to 12" (CAN) any other appliance.
- K = 3 ft. (USA) Clearance to a mechanical air supply inlet.
6 ft. (CAN)
- L* = 7 ft. (USA) Clearance above paved side-walk or a paved driveway located on public property.
- M** = 12" Clearance under veranda, porch, deck or balcony

* A vent shall not terminate directly above a side-walk or paved driveway which is located between two single family dwellings and serves both dwellings.

** Only permitted if veranda, porch, deck or balcony is fully open on a minimum of 2 sides beneath the floor.

• Note: Local Codes or Regulations may require different clearances.

INSTALLATION

GAS SUPPLY HOOKUP

If using pipe other than black iron pipe see NFPA 54-National Fire Protection Association / ANSI Z223.1-American National Standards Institute; and local code for specific requirements for the type of pipe used. Alternative gas piping systems such as CSST may be used subject to local code and proper sizing.

CAUTION

To avoid pipe compounds from entering system, apply compounds only to male pipe threads. Do not apply compound to the first two threads.

This appliance is equipped with a flexible gas line and fitting for a gas supply line connection. Connection can be made using either the 3/8" NPT male fitting or, by removing the fitting, to the flex line 3/8" female flare. The flex line can be routed to the gas supply through either the pedestal bottom or through the rear pedestal cover depending upon the orientation of the supply line. Some areas may have certain restrictions against the use of flexible gas lines. Check local codes. The gas appliance control valve has a 3/8" NPT female type inlet for the gas supply line, if hard plumbing is required.

If the gas supply will be routed to the appliance from the rear, the flexible gas line for hookup is readily accessible. If the gas supply will be routed to the appliance through the flooring, remove the rear panel. Redirect the flexible gas line through the large hole in the center of the pedestal base for gas supply connection.

A gas supply line must be run to the appliance by a qualified professional. The plumbing of the gas line must comply with National Standards; NFPA 54-National Fire Protection Association / ANSI Z223.1-American National Standards Institute; and local code.

Gas piping must not run in or through air ducts, clothes chutes, chimneys or gas vents, dumb waiters or elevator shafts.

Piping should be sloped 1/4" per 15 feet (6mm per 4.6m) upward toward the meter from the appliance. The piping must be supported at proper intervals every 8 to 10 ft. (2.4m to 3.1m) using suitable hangers or straps.

The gas supply line must be purged of air before it is connected to the appliance.

An accessible, approved shut-off valve must be installed upstream of any connector so that the appliance may be isolated to allow service, removal, and replacement (within six feet of the appliance per NFPA 54, or twelve inches in some codes). A shut-off valve is provided with this appliance.

IMPORTANT: In case emergency shut-off is required, shut off main manual gas valve and disconnect main power to appliance. These devices should be properly labeled by the installer.

PRESSURE TESTING:

- The appliance main gas valve must be disconnected from the gas supply piping system during any pressure testing of that system at test pressures in excess of *1/2 psi (3.5 kPa).

- The appliance must be isolated from the gas supply piping system by closing its individual manual shut-off valve during any pressure testing of the gas supply piping system at test pressures equal to or less than *1/2 psi (3.5 kPa).

Make the connection to the gas supply line using the correct fitting required to the shut-off valve.

Install a drip leg where condensates might accumulate. Sediment traps, like drips and collection tees, are required to be installed. Traps collect moisture and intercept and hold foreign objects which might block orifices and valves. A drip leg should be installed in vertical pipe runs to the appliance.

Supply Line Size Requirements

The proper gas line diameter must be used to run from the supply regulator (at the gas company meter) to the appliance. Never use galvanized or plastic pipe. Refer to the table below for suggested sizing of the gas supply line.

**Suggested Sizing of
Schedule 40 Pipe Supply Line**

Schedule 40 Pipe Length (Feet)	Schedule 40 Pipe Inside Diameter (Inches)	
	Natural Gas	LP. Gas
0-10	1/2	3/8
10-40	1/2	1/2
40-100	1/2	1/2
100-150	3/4	1/2
150-200	3/4	1/2

Use an approved pipe sealant compound for NPT fittings. After all pipe connections are made, apply normal gas line pressure: 7.0" W.C. for natural gas; 11.0" W.C. for LP gas (propane) and use an approved leak detection solution to test for the tightness of each pipe connection joint.

IMPORTANT

Compounds used on threaded joints of gas piping must be resistant to the actions of liquified petroleum gases.

IMPORTANT: All connections must be checked for leaks with a leak detector or soapy water solution. Never check for gas leakage with an open flame!

CAUTION

Some soaps used for leak detection are corrosive to certain metals. Carefully rinse piping thoroughly after leak test has been completed. Do not use matches, candles, flame or other sources of ignition to check for gas leaks.

* Note: 1/2 psi = 14" WC (inches water column).

INSTALLATION

DOOR OPERATION

After setup of the logs and embers is complete, the glass door must be closed. The glass door is mounted on hinges at the left side of the firebox and is secured in the closed position by two draw latches mounted on the right side of the firebox. The latch tension is preset at the factory. Over time, adjustment of the latch tension may be necessary to maintain a tight door seal. This adjustment can be made by spinning the latching rod in the rod guide. Care should be exercised to not adjust the tension too high. **Caution: Never operate the appliance with the glass door open.**

If glass door removal is required for replacement or maintenance, the door can be removed. Do not attempt to remove or replace broken glass in the door assembly. Contact your Lennox dealer for glass replacement. To Remove Door:

1. Remove the glass door assembly from appliance as follows:
 - a. Open the right and left side panels (held closed by magnets in the front. The panels hinge to back).

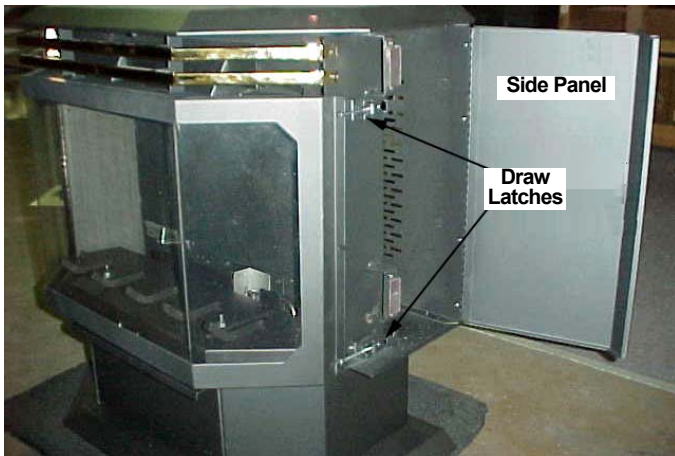

- b. Open the two draw latches mounted on the right side of the door by pulling them forward. Swing open door. See picture in left column of this page showing their location.
- c. With the door open, lift the door straight up and off the hinge pins. Set door aside.



INSTALLATION

GAS APPLIANCE FINAL ASSEMBLY

After the appliance has been properly installed and all gas connections have been made and tested, you can now install the log set. See *Door Assembly* on page 14 for door removal instructions.

INSTALLING LOG SET:

WARNING: If logs are not installed according to the directions in this manual, flame impingement and improper combustion could occur and result in excessive production of carbon monoxide (CO), a colorless, odorless, toxic gas.

This appliance is equipped with a five-piece log set. Carefully install the logs into the firebox as shown on this page. All logs should fit down onto pins and mounts provided. This will ensure a proper flame and safe combustion.

1. Carefully place the largest log in the rear of the firebox as shown in the following illustration.



2. Install the front log as shown in the following illustration.



3. Install the right top twig as shown in the following illustration.



4. Install the center top twig as shown in the following illustration.



5. Install the left top twig and embers as shown in the following illustration (see *Glowing Embers* on this page).



Glowing Embers

One package of ember material has been included with this gas appliance. You will not need to use the entire bag (additional ember material is provided for your future maintenance needs).

IMPORTANT: The quantity and placement of the ember material can affect stove performance therefore it is very important that it be placed as shown in the picture on instruction # 5 and shown below.

Proper Placement of Ember Material: Unpackage and divide the fine ember material (mineral wool) into thumbnail sized fluffy pieces. Distribute the pieces over the top of the front burner ports and filling the area in front of and beneath the forward log and running the full length of the log.



INSTALLATION

INSTALLATION CHECK LIST

Read and understand these instructions before using appliance. Go through this installation checklist:

- ❑ Ensure that the log set is properly installed. Use caution when handling the logs. See page 12.
- ❑ Reinstall the door frame assembly. See *Door Assembly* on page 14.

WARNING: Do not operate appliance with the glass front removed, cracked or broken. Replacement of the glass should be done by a qualified technician.

- ❑ Ensure venting termination cap is unobstructed.
- ❑ Check to see that wiring is correct and is enclosed inside the stove pedestal base (See page 21).
- ❑ Ensure that the 3 relief doors on the back and sides of the appliance are properly closed (see *Combustion Chamber Relief Doors* on page 16).
- ❑ Verify that the gas line has been purged of air.
- ❑ Test all connections for leaks (factory and field) with a leak detector or soapy water solution. If you smell gas, do not attempt to light this appliance. Follow safety instructions on the front cover of this manual.
- ❑ Burner Air Shutter opening to be:
Natural Gas – 1/2 open, Propane 3/4 open.

Some adjustment from standard may be necessary for the desired flame characteristics (see *Burner Flame Appearance*, page 20). To adjust air shutter:

1. Remove burner from firebox by removing the 2 nuts as shown in the following picture. Then lift burner up and out of firebox.

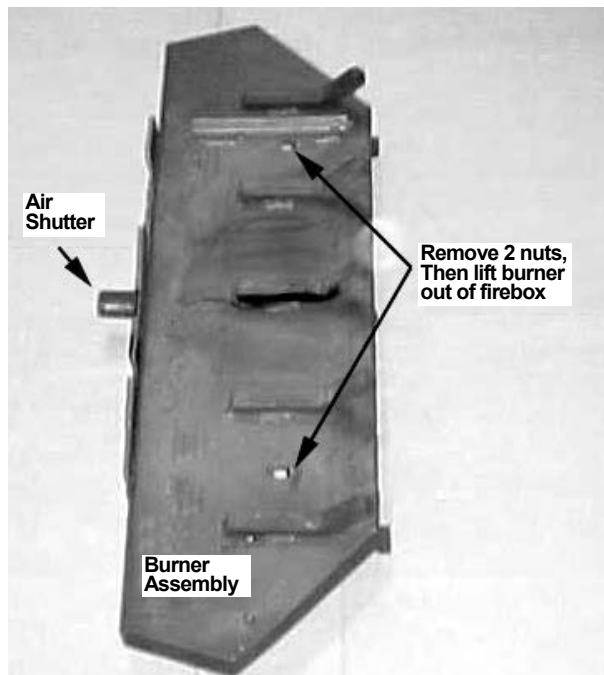

2. Adjust gap as shown in following picture.

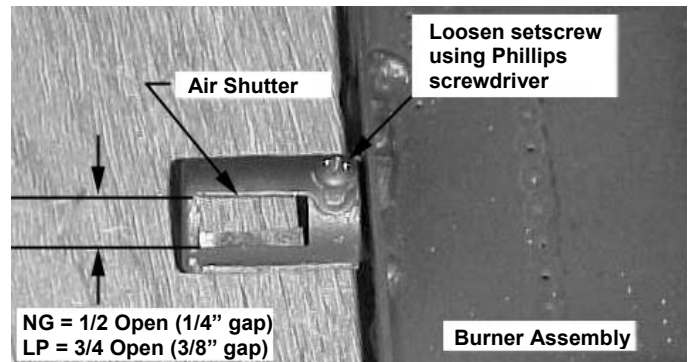

3. Reinstall burner. Do not overtighten nuts (finger tight only).

- ❑ Light the appliance following the instructions on page 15 (*Care and Operation*). Relight the main burner in both the HI, and LO positions, and verify proper burner ignition and operation.

NOTE: Upon the initial firing of your new gas stove, you may notice an odor. This may last up to two hours. It is recommended to open the windows to allow fresh air to circulate into the room.

WARNING: If the pilot does not light after 1 minute, wait at least 5 minutes for gas to clear before attempting again.

- ❑ With burner lit, check to make sure that the inlet gas and manifold pressures are correct (see *Gas Pressure*, page 4). Verify that the pilot and main burner ignition and operation are correct.
- ❑ Plug blower power cord into an 120 V, 60Hz, grounded outlet (See *Air Circulation Blower*, Page 4).

CARE AND OPERATION

FOR YOUR SAFETY READ BEFORE LIGHTING

WARNING: If you do not follow these instructions exactly, a fire or explosion may result causing property damage, personal injury or loss of life.

- A. This appliance has a pilot which must be lit. When lighting the pilot, follow these instructions exactly.
- B. BEFORE LIGHTING smell all around the appliance area for gas. Be sure to smell next to the floor because some gas is heavier than air and will settle on the floor.
- WHAT TO DO IF YOU SMELL GAS:
- Do not try to light any appliance.
 - Do not touch any electric switch; do not use any phone in your building.
 - Immediately call your gas supplier from a neighbor's phone. Follow the gas supplier's instructions.
 - If you cannot reach your gas supplier, call the fire department.
- C. Use only your hand to push in or turn the gas control knob. Never use tools. If the knob will not push in or turn by hand, don't try to repair it, call a qualified service technician. Force or attempted repair may result in a fire or explosion.
- D. Do not use this appliance if any part has been under water. Immediately call a qualified service technician to inspect the appliance and to replace any part of the control system and any gas control which has been under water.

Gas Control Knobs

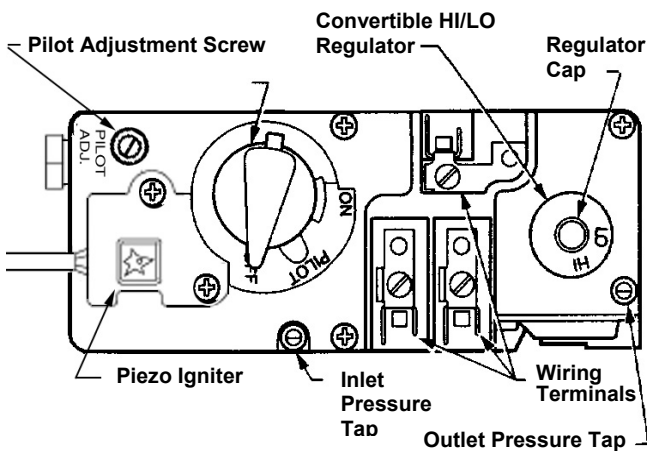

Pilot Assembly

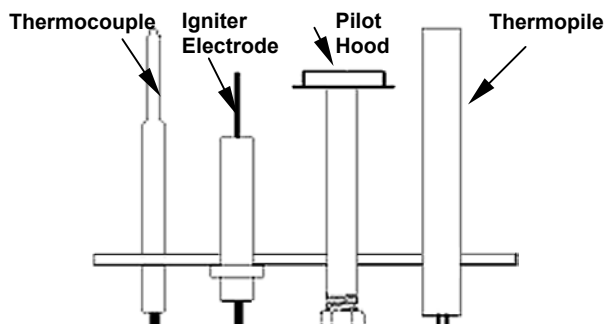

LIGHTING AND SHUTDOWN INSTRUCTIONS

1. STOP! Read the safety information on this page or on label (on appliance).
2. Turn off all electrical power to the appliance (unplug blower power cord). Make sure the burner ON/OFF switch is in the OFF position.
3. To gain access to the gas controls, swing the control access door open. The control access door is located directly under the window.
4. Push in gas control knob slightly and turn clockwise \curvearrowright to "OFF."
NOTE: Knob cannot be turned from "PILOT" to "OFF" unless knob is pushed in slightly. Do not force.
5. Wait five (5) minutes to clear out any gas. Then smell for gas, including near the floor. If you smell gas, STOP! Follow "B" in the safety information above on this label. If you don't smell gas, go to the next step.
6. Visually locate the pilot located in the center of the firebox beneath the rear ceramic log.
7. Turn knob on gas control counterclockwise \curvearrowleft to "PILOT."
8. This appliance contains a spark ignition system (piezo igniter), which is used to light the pilot. Push in the gas control knob all the way and hold it in. Immediately press the button on the piezo igniter located to the left of the gas control knob. The spark produced by the piezo igniter should light the pilot. Continue to hold the control knob in for about one (1) minute after the pilot is lit. Release the gas control knob and it will pop back up. Pilot should remain lit.
 - If it goes out, repeat steps 4 through 8.
 - If the knob does not pop up when released, stop and immediately call your service technician or gas supplier.
 - If the pilot will not stay lit after 3 or 4 tries, turn the gas control knob to "OFF" and call your service technician or gas supplier.
9. Turn gas control counterclockwise \curvearrowleft to "ON." Use rocker switch, located either on the control panel or the exterior side panel, to operate main burner. Adjust variable pressure dial (RB Regulator / Flame Height Control) to set burner flame to desired heat output.
10. Swing the control access door closed.
11. Turn on electrical power to the appliance (plug in blower power cord. See page 16, *Circulation Blower Operation.*)

TO TURN OFF GAS TO THE APPLIANCE

1. Turn off all electric power to the appliance if service is to be performed.
2. To gain access to the gas controls, swing the control access door open. The control access door is located directly under the window.
3. Push in gas control knob slightly and turn clockwise \curvearrowright to "OFF."
NOTE: Knob cannot be turned from "PILOT" to "OFF" unless knob is pushed in slightly. Do not force.
4. Swing the control access door closed.

CARE AND OPERATION

“BREAK-IN” PERIOD

The finish on this appliance is a high temperature paint that requires time and temperature to completely cure. The curing process will take 2 or 3 burns (heat up and cool down periods). We recommend that you ventilate the house during the initial burns. The paint emits non-toxic odors during this process.

KEEP YOUR HOUSE WELL VENTILATED DURING THE CURING PROCESS TO PREVENT ACTIVATION OF YOUR HOME SMOKE DETECTOR.

Do not turn on a blower during the break-in period. Do not place anything on the stove surface until the paint is completely cured. Do not attempt to repaint the stove until the paint is completely cured. If the surface later becomes stained or marred, it may be lightly sanded and touched up with spray paint (See *Small Area Paint Touch-Up*, page 19). Paint is available at your local authorized Lennox Hearth Products dealer. Never attempt to paint a hot stove.

COMBUSTION CHAMBER RELIEF DOORS

This appliance is equipped with 3 relief doors (one behind the back panel, and one on each side, behind side panels) in case of delayed ignition blow back. If one or more relief doors open, inspect for gasket damage. If necessary, replace with factory supplied gasket only. Confirm relief doors are closed and properly seated.

CIRCULATION BLOWER OPERATION

The speed of the circulation blower is controlled using the speed control rheostat (see following illustration) on the left hand side of the control panel. The blower system is designed with a variable speed control allowing an infinite range of blower settings to meet the customer’s needs. With the rotary switch turned fully CCW ⤴, the blower is off. Turning the switch CW ⤵ will activate the blower at its maximum speed. Further rotation of the switch in the CW direction will reduce the speed of the blower. At approximately 270° of CW ⤵ rotation, the switch provides a minimum setting for blower speed.

Thermostatic feature: With the control switch in any “ON” position, the circulation blower is designed to automatically begin operation approximately 12 minutes after lighting the main burner. The blower will turn off approximately 15 minutes after the main burner is shut-off.

Variable Speed Control for Air Circulation Blower

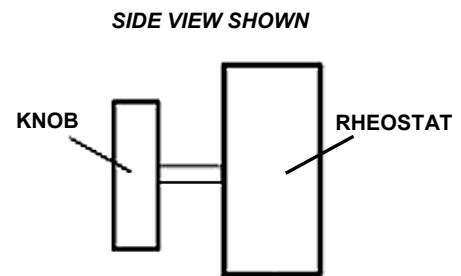

PROPANE CONVERSION

PROPANE CONVERSION PROCEDURE

(Only required if Propane gas is used)

This appliance is designed to operate on natural gas, or propane (LP). It is factory set for use with natural gas and requires field conversion for use with propane. The use of other fuels or combination of fuels will degrade the performance of this system and may be dangerous.

When converting to Propane Gas (LP), it may be necessary to install (as a minimum) 3 feet of vertical pipe from the appliance prior to an offset to ensure optimum product performance. This may be necessary due to variations in vent configuration and other numerous factors which affect exhaust flow and air delivery such as BTU value, ambient temperature, wind conditions, altitude, etc.

The conversion kit provided with this appliance contains components required to convert this appliance from use with natural gas to use with propane (LP) Gas. All of the components in the propane conversion kit must be installed in order for the appliance to operate safely on propane.

Installation Tools / Supplies

7/16" Open end wrench

Small standard screwdriver

Pipe sealant compound (*must be rated for use with LPG gas*)

Parts List

- Propane RB Regulator conversion screw (Red indicates LP gas)
- Burner Orifice (*If you are at an elevation above 4500 feet do not use the orifice provided in this kit. Contact your gas supplier to obtain a smaller orifice*)
- Pilot Orifice
- Label, Converted to (LP) Propane – Affix to valve
- Label, Converted to (LP) Propane – Affix to stove body

Avertissement: cet équipement de conversion sera installé par une agence qualifiée de service conformément aux instructions du fabricant et toutes exigences et codes applicables de l'autorisés avoir la juridiction. Si l'information dans cette instruction n'est pas suivie exactement, un feu, explosion ou production de protoxyde de carbone peut résulter le dommages causer de propriété, perte ou blessure personnelle de vie. L'agence qualifiée de service est esponsable de l'installation propre de cet équipement. L'installation n'est pas propre et complète jusqu'à l'opération de l'appareil converti est chèque suivant les critères établis dans les instructions de propriétaire provisionnées avec l'équipement.

IN CANADA:

The conversion shall be carried out in accordance with the requirements of the provincial authorities having jurisdiction and in accordance with the requirements of the CAN1-B149.1 and .2 Installation code.

La conversion devra être effectuée conformément aux recommandations des autorités provinciales ayant juridiction et conformément aux exigences du code d'installation CAN1-B149.1 ET.2.

⚠ WARNING

Conversion components must be installed by a qualified service agency in accordance with these instructions and all applicable codes and requirements of the authority having jurisdiction. If the information in these instructions is not followed exactly, a fire, explosion or production of carbon monoxide may result, causing property damage, personal injury or loss of life. The qualified service agency is responsible for the proper installation of this kit. The installation is not proper and complete until the operation of the converted appliance is checked as specified in these instructions.

PROPANE Conversion Procedure

1. Turn off Gas - Turn gas control knob to the off position, and shut off the gas supply to the valve. If necessary, disconnect appliance from gas supply.
2. Caution: The gas supply shall be shut off prior to disconnecting the electrical power, before proceeding with the conversion. Unplug blower power cord.
3. If the installation is at an elevation below 4500 feet, proceed to step 4. If you are at an elevation above 4500 feet, do not use the orifice provided in this kit. Contact your gas supplier to obtain a smaller orifice).
4. Burner Orifice Installation Procedure:
 - a. Remove glass door.
 - b. Remove logs, burner cover, and burner.
 - c. Use a 7/16" open-end wrench to remove gas burner orifice.
 - d. Replace the burner orifice with the appropriate burner orifice (see instruction #3).
 - e. Use pipe sealing compound rated for LP gas. BE VERY CAREFUL THAT THE PIPE COMPOUND DOES NOT GET INSIDE OF THE ORIFICE (THIS COULD RESULT IN PLUGGING OF THE ORIFICE). Using a 7/16" open-end wrench to tighten orifice - DO NOT OVER TIGHTEN (finger tight, then 1/2 turn maximum). *Make sure the orifice is inserted fully into the primary air shutter fixed opening.
5. Adjust primary air shutter. Burner Air Shutter opening to be: Natural Gas – 1/2 open, Propane 3/4 open. Some adjustment from standard may be necessary for the desired flame characteristics (see *Burner Flame Appearance*, page 20).
6. Replace Pilot Orifice - Using a 7/16" open-end wrench, remove the pilot burner hood. Replace the pilot orifice with the one supplied in the propane conversion kit. Then, reinstall the pilot burner hood. Ensure that the mark on the pilot hood is lined up with the mark on the pilot mounting plate.

PROPANE CONVERSION

7. High / Low Pressure Regulator Installation Procedure:
 - a. Remove regulator cap and conversion screw (see following illustration).
 - b. Install the new conversion screw (Red = Propane LP gas, Blue = Natural Gas). Ensure that the conversion screw is finger tight. Install the new regulator cap.
 - c. Affix conversion label on gas control valve body where it can easily be seen.

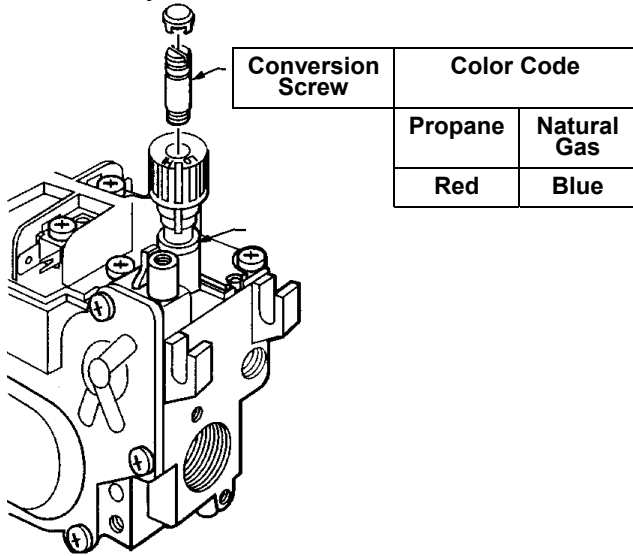

8. Reinstall burner cover, logs, ember wool / ceramic rocks and glass front.
9. Purging Air from Supply Line:
This should only be done by a qualified and licensed (where applicable) professional. Check with your local building official for qualifications required to perform this procedure.

10. Purge air from the gas line (see #9 above), then connect propane gas line to the appliance. Connect the fuel line to the insert inlet (1/2" NPT fitting) using the fitting required.
11. Perform leak Test.

CAUTION

After this procedure is complete with appliance installed and connected to gas line, recheck the pilot connection and manifold fittings for leaks, using soapy water or a gas leak detector.

12. Lighting Procedure-See page 14.

Note: If the gas control knob is turned to the "off" position after pilot has been lit, the appliance must be allowed to cool for at least five minutes before pilot flame can be relit.

13. Apply the propane conversion label to the rating label.

The Appliance is ready for use with propane fuel as its only fuel.

REFERENCE INFORMATION

See pages 4, and 26 of this manual for the following reference information:

- Manifold Gas Pressure
- Inlet Gas Pressure
- Input Ratings

BURNER FLAME APPEARANCE

A periodic visual check of burner flames should be performed. The burner flame should appear as indicated on page 20 - *Burner Flame Appearance*.

MAINTENANCE

Always Turn Off Gas Control Valve Before Cleaning. Annual Maintenance Should Only Be Performed By A Qualified Service Technician:

LOG SET

Removing & Cleaning Logs - Carefully remove the logs (removing top logs, then lifting front log out, then rear log). Use care when handling the fiber logs, as they become quite fragile after curing. Use a small soft-bristled brush (e.g., a nylon paint brush) to remove soot, dust or debris that may have accumulated on the burner or log set. Remove the logs and burner, and clean them outside the home in a location with plenty of fresh air ventilation. Avoid breathing fine particulates of dust that may be generated. See page 12, *Installing Log Set* for instructions on reinstalling logs.

Replacing Logs - If logs become damaged by accident or improper handling and need replacement, use only the proper replacement logs from manufacturer, which can be purchased from your local dealer. See page 23.

CLEANING BURNER

With the logs removed, vacuum out any foreign matter (lint, carbon etc.) on the burner. Be sure the burner ports are "open."

CLEANING VALVE / AIR VENTURI

Clean all lint and dust build-up around the control valve and air shutter on the venturi. Inspect and clean with a brush or wire the inlet of the venturi for any spider webs or lint accumulation.

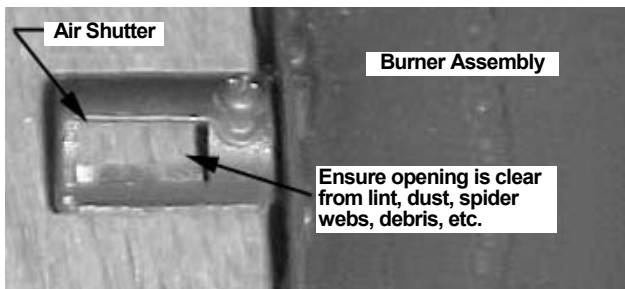

INSPECT WIRING / CAUTIONS:

- 1) Label all wires prior to disconnection when servicing controls. Wiring errors can cause improper and dangerous operation.
- 2) Verify proper operation after servicing.
- 3) Inspect and clean all wire connections. Ensure that there is no melting or damage from rodents. Inspection should include:
 - Terminals at the valve
 - On / Off switch
 - Wall Thermostat / Remote Control (optional kits)

VENTING SYSTEM

A periodic examination of the venting system must be performed to ensure that the flow of combustion and ventilation air is not obstructed (outlet and inlet is open and free from blockage). We recommend that you have your gas appliance checked yearly by your independent Lennox dealer.

If the vent-air intake system is disassembled for any reason, the service technician should follow vent manufactures instructions for proper reassembly and sealing of the vent-air intake system.

IMPORTANT – APPLIANCES INSTALLED USING SIMPSON DURA-VENT BRAND PIPE MUST SEAL ALL JOINTS WITH MILL-PAC BLACK, HIGH TEMPERATURE SEALANT.

CLEAN EXTERNAL SURFACES

External surfaces should be kept clean and dust removed from air inlets to the appliance. The flow of combustion and ventilation air must not be obstructed. The appliance must be kept clear and free from combustible materials, gasoline and other flammable vapors and liquids.

SMALL AREA PAINT TOUCH-UP

The stove body is painted with a quality high-temperature stove paint. Use only model TSPK-C Stove Paint, Catalog # 19L92. Do not touch-up this appliance with any other paint.

Using one small piece of 320 grit sand paper and lightly sand the blemish so that the edges are "feathered" or smooth to the touch between the painted and bare surfaces. Do not let the sand paper gum up with paint, as this will cause scratches on the metal surface. If there are any scratches, use 600 grit sandpaper instead. Mask off surfaces you do not want painted. Paint lightly over the bare surface first as this will act as an undercoat. Then paint over a larger area in smooth even strokes to blend.

See *Break-In Period* on page 16 for information on curing the paint.

CLEANING GLASS

The window on the gas appliance is made from a clear ceramic material and may be cleaned when cool with any non-abrasive product designed for use on glass windows. **Do not use abrasive cleaners on glass.** The viewing glass should be cleaned periodically. Exterior glass may be cleaned with a glass cleaner as desired. Interior glass - use soap and water, or commercial glass cleaner recommended for stove glass.

Note: Each time the appliance is lit, it may cause condensation and fog on the glass. This condensation and fog will disappear in a few minutes.

CLEANING BLOWER INTAKE

The blower air intake requires cleaning at least once a year to remove lint, dust, etc. If there are pets in the dwelling, the intake should be cleaned at least twice a year.

MAINTENANCE

Always Turn Off Gas Control Valve Before Cleaning. Annual Maintenance Should Only Be Performed By A Qualified Service Technician:

PERIODIC CHECK OF PILOT AND BURNER FLAMES

Check the operation of the pilot and cycle the burner. Visually check the flame of the burner making sure the flames are steady; not lifting or floating. The flame color should be blue at the burner with yellow body and tops.

Cycle unit a minimum of 2 times

- Watch for smooth burner ignition and shut down.
- Burner: Check flame patterns. Ensure that burner flame appearance does not vary greatly from diagram shown on this page.
- Pilot: Ensure pilot flame appearance does not vary greatly from diagram shown below.

PILOT FLAME APPEARANCE

A proper pilot flame should consist of torch-like flame issuing from the pilot hood as shown in illustration below.

Proper Pilot Appearance

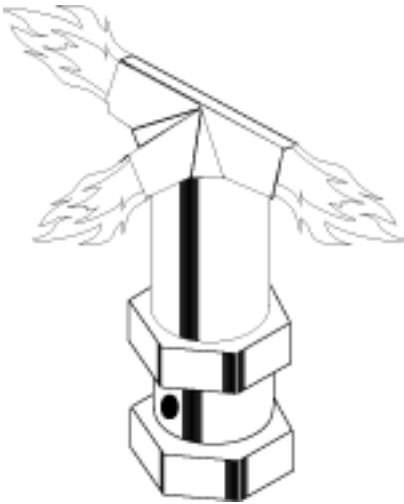

BURNER FLAME APPEARANCE

A periodic visual check of the pilot and burner flames should be performed. If either the pilot or burner flame do not show proper appearance or behavior, as outlined here, consult a qualified gas appliance technician.



A proper burner flame is shown above. The burner flame should have the following characteristics after initial start-up (let appliance burn 15 to 20 minutes prior to accessing flame appearance):

- Excessive impingement (contact of flame with logs) should not occur.
- Rear burner flames should have yellowish tips; no soot should form at burner flame tips.
- Flames should not raise off of burner (no “lifting” of flame).

Air Shutter Adjustment

The flame can be adjusted to give the proper flame appearance and to prevent sooting on the window or logs by adjusting the position of the primary air shutter (located at the rear center inlet to the burner). The air shutter should be positioned approximately 1/2 open for Natural Gas and approximately 3/4 open for LP Gas. See page 13, *Burner Air Shutter*.

NOTE: During periods of high natural gas demand, the gas supplier may add “make-up gases” to the pipeline. This addition will change the composition of the supply gas, and may cause a change in burner flame appearance. You may also notice soot formation on the logs and viewing windows. Check with your gas supplier if you suspect a change in the composition of your gas supply.

WIRING DIAGRAMS

GAS CONTROL AND SAFETY SYSTEM WIRING DIAGRAM

CAUTION: Label all wiring prior to disconnection when servicing controls. Wiring errors can cause improper and dangerous operation. Verify proper operation after servicing.

The gas control wiring diagram shown here should be used by service technicians for guidance when troubleshooting problems with the pilot safety (millivolt) system or burner remote control system or when locating system components for repair / replacement. Note: If replacement of any of the original wire is necessary, use 105°C thermoplastic wiring.

GAS CONTROL AND SAFETY SYSTEM WIRING DIAGRAM

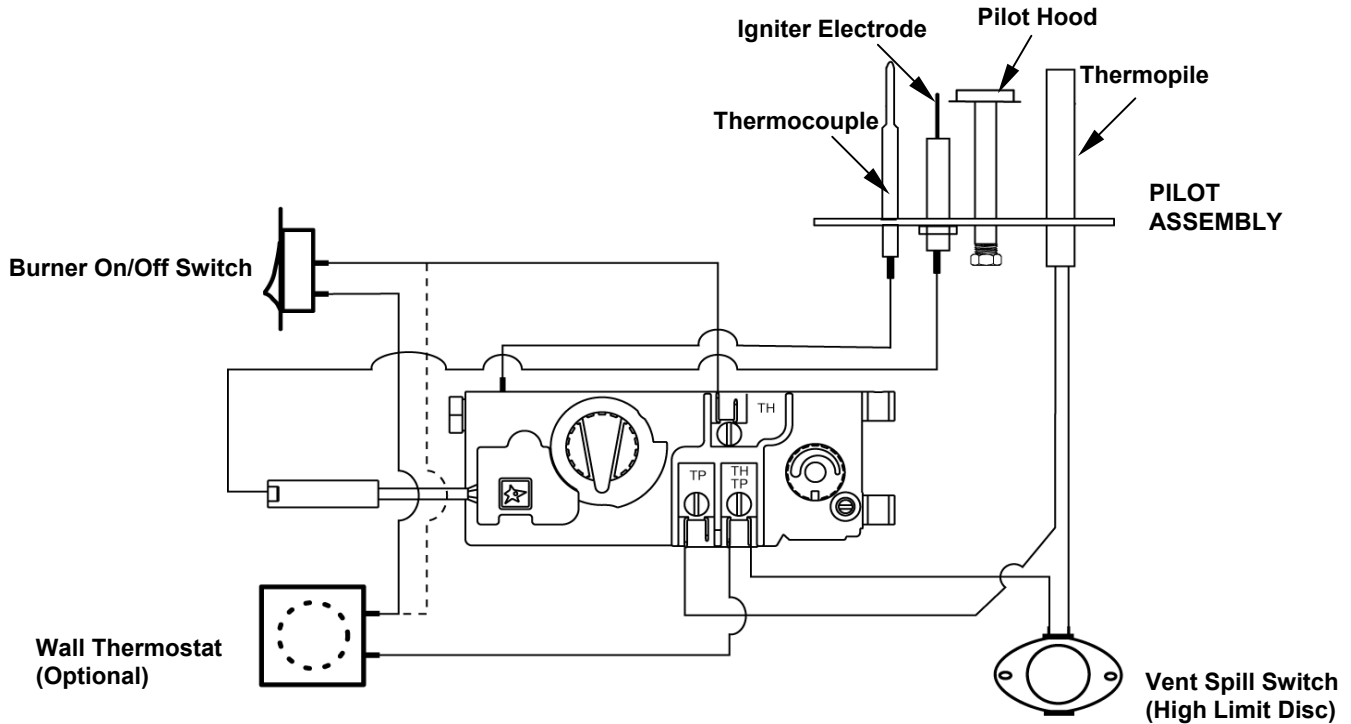

CIRCULATING BLOWER WIRING DIAGRAM

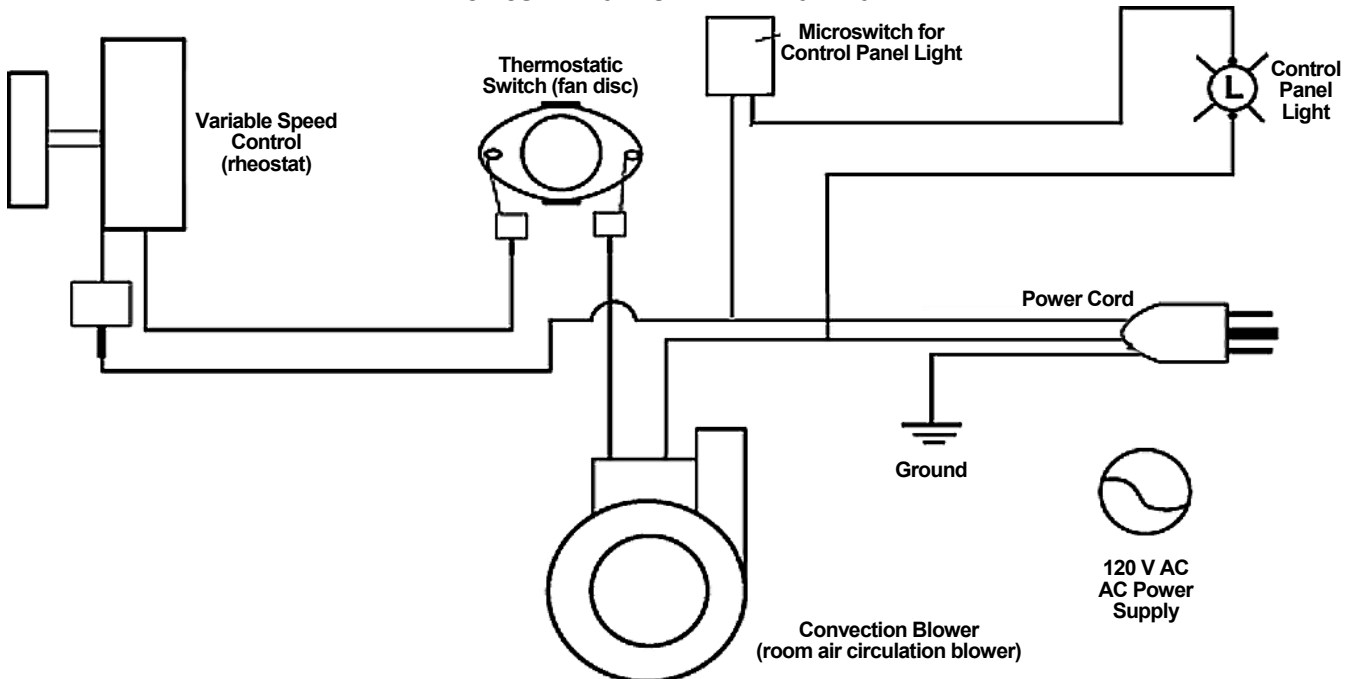

TROUBLESHOOTING *Qualified Technicians Only*

PROBLEM	CAUSE(S)	SOLUTIONS
1) Pilot will not light, and Piezo Igniter does not produce a heavy blue spark.	a. Electrode wire (at Piezo Igniter) not pushed completely on. b. Piezo igniter is defective	<ul style="list-style-type: none"> • Make sure connections are solid. • Replace piezo igniter.
2) Pilot will not light, but Piezo Igniter produces a heavy blue spark.	a. Incorrect lighting procedure. b. No gas to appliance due to shut valves or disconnected gas lines.	<ul style="list-style-type: none"> • Carefully follow the lighting / operating instructions found in the appliance of this owner's manual. • Check for multiple gas shut-offs; check gas supply lines.
3) Pilot will not stay lit.	a. Thermocouple is not firmly connected to control valve. b. Pilot flame is not directed to top of thermocouple. c. Thermocouple is defective. Make sure connection is solid.	<ul style="list-style-type: none"> • Ensure thermocouple is fully inserted into pilot assembly. • Replace thermocouple.
4) Pilot flame stays lit, but main burner will not light.	a. Burner control switch (on control panel) is in "OFF" position; or thermostat (if installed) is turned off or temperature setting is too low. b. Electrical wiring is damaged or poorly connected c. One of the following components may be defective: burner control switch, thermostat, or thermopile.	<ul style="list-style-type: none"> • Position the burner control switch to "ON"; or adjust the thermostat. Refer to manufacturer's instructions for thermostat. • Refer to Control and Safety Wiring Diagram (Figure 11) and check electrical connections. • Refer to Control and Safety Systems Wiring Diagram. Electrically bypass components one at a time and replace defective item.
5) Smell of gas	a. Loose fittings may be allowing gas to leak out.	<ul style="list-style-type: none"> • Check all joints for leakage: pilot assembly, gas supply system, main burner assembly, pilot and burner adjustment screws. Use a proper leak check solution. WARNING: Never use an open flame to check for leaks.
6) A thin coating of black soot forms on the window. NOTE: See page 19, <i>Cleaning Glass</i> .	a. Burner primary air inlet is restricted or blocked. b. Flames make contact with logs or other surfaces. c. Improper venting.	<ul style="list-style-type: none"> • Be sure all openings (fresh air inlets) in stove are free from dust and debris. Re-check these areas periodically. • Make sure ceramic logs are in their correct positions. • Check for flue blockage, disconnected flue, improper installation, negative air pressure inside building (with respect to exhaust exit), or "down draft" situation. Make appropriate corrections.
7) A white coating forms on windows, logs, and / or inside walls of firebox.	a. Residues / impurities being burned off.	<ul style="list-style-type: none"> • Follow cleaning guidelines outlined in the MAINTENANCE section of this manual.
8) Circulation blower makes a humming sound, but there is no circulation air.	a. Impeller blades in circulation blower are dirty. b. Circulation blower is defective.	<ul style="list-style-type: none"> • Disconnect electrical power to circulation blower, access blower and clean impeller blades as outlined in the MAINTENANCE section of this manual. • Replace blower.

REFERENCE INFORMATION FOR QUALIFIED TECHNICIAN:

Thermopile / Thermocouple Operation

- Thermopile: Millivolt production should be a minimum of 325 MV with pilot only.
- Thermocouple: Millivolt production should be a minimum of 14 MV with pilot only.

Drop out rate

- TP 50-60 MV
- TP 1 1/2-2 Min. (3 max.) if longer, replace thermopile.

REPLACEMENT PARTS Model: L30 DVF-2

Item #	Description	Cat. No.
1	Trim, Decorative	10050164
2	Window Frame, Charcoal	17M60
3	Burner Assembly	17M58
4	Blower, Air Circulating	52L02
5	Thermal Fan Switch	52L12
6	Power Cord (blower)	12058820
7	Rheostat w / Knob (speed control for blower)	10050088

Item #	Description	Cat. No.
8	On / Off Switch, Pkg. of 3	52L13
9	Control Valve NG (with LP Conversion Kit)	64L98
10	(0-4500') Orifice, #31, NG, Pkg. of 10	18750031
10	(0-4500') Orifice, #50, LPG, Pkg. of 10	10850183
10	(4500') Orifice, #32, NG, Pkg. of 10	52L06
10	(4500') Orifice, #51, LPG, Pkg. of 10	10850184
11	Pilot Assembly NG	52L15
12	Log Set, 5 pc. (with embers)	17M59

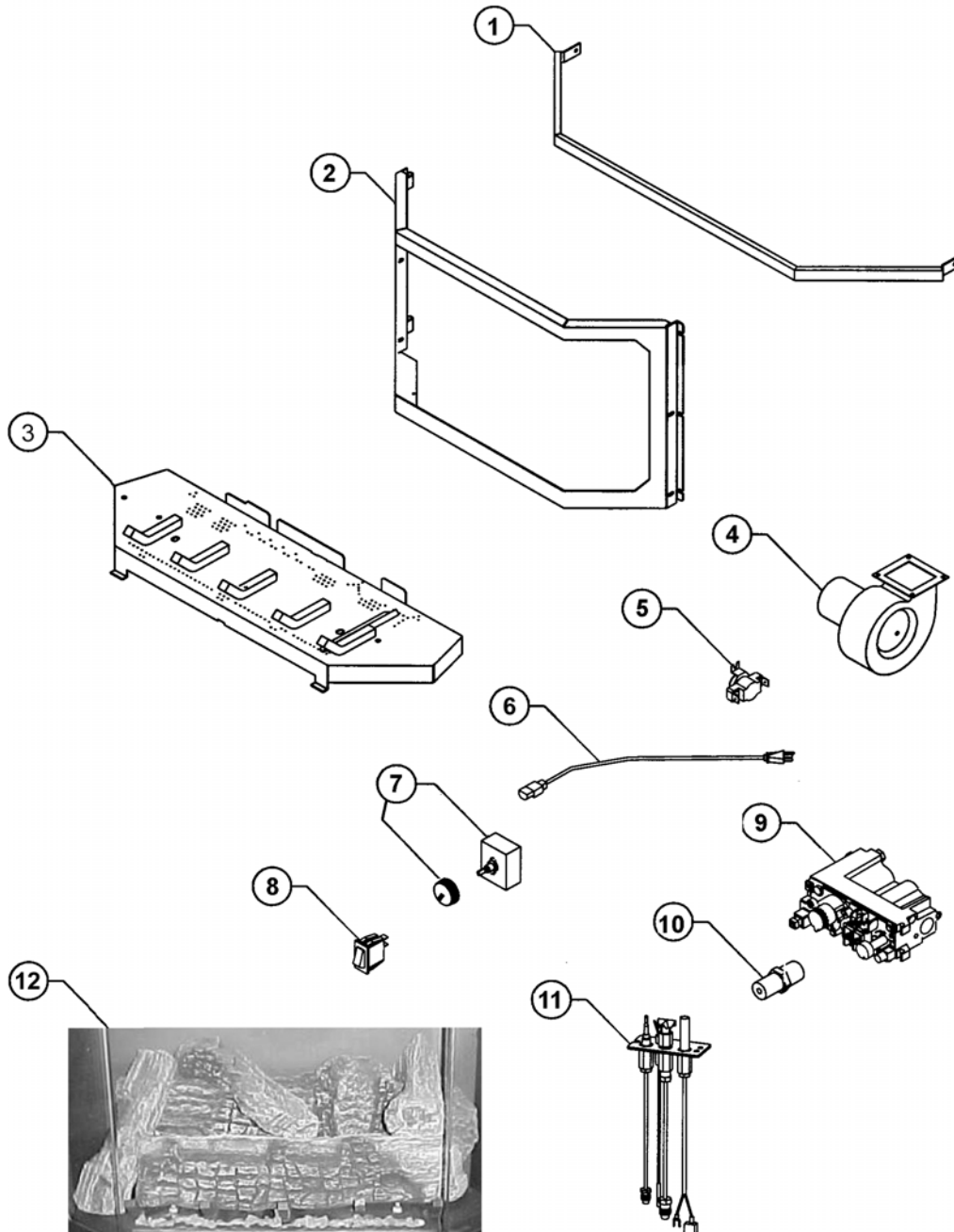

OPTIONAL ACCESSORIES

Item #	Description	Catalog #	Model
1	Door Kit, L30 DVF-2, Gold	14M08	DK3D-G
2	Brickaded Interior Kit, L30	14M06	BRK-L30
3	Deluxe Remote Control (Thermostatically controlled)	H0251	RC-STAT
4	Remote Control (Standard On / Off)	H0249	RC
5	Wall Thermostat Kit	89L36	WTK
6	Touch-up Spray Paint Kit, Charcoal	19L92	TSPK-C
7	Glowing Embers, 1 oz bag	88L53	FGE

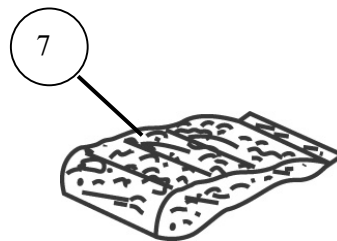
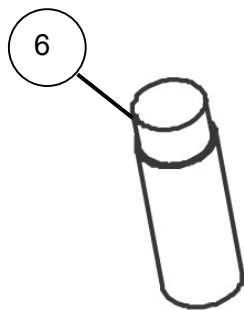
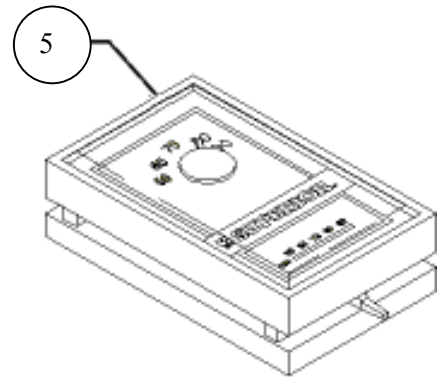
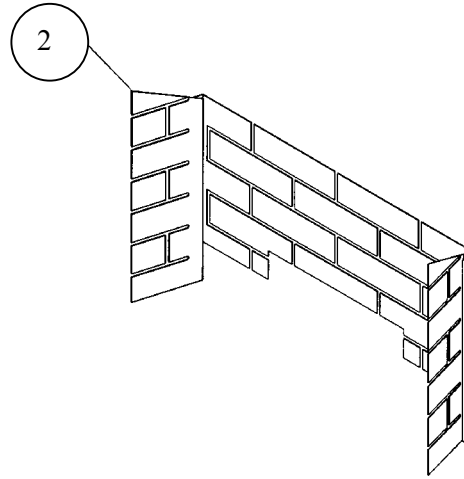
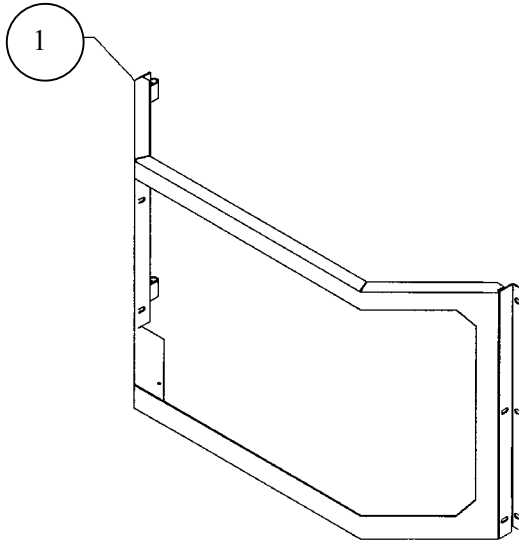

SPECIFICATIONS: Model L30 DVF-2

Flue Size	4" – Top Vent
Intake Pipe	6.625" (6 5/8")
Height Overall	30 5/8"
Height	29 1/8"
Width	30 1/8"
Depth	16 1/8"
Fuel	Natural Gas (standard) (or) LP Gas (convertible). Gas inlet 3/8" NPT-Male/Flex Line (or) remove flex, 3/8" NPT–Female Flare.
Performance Features	Variable Flame Control. High Efficiency Heat Exchanger. Natural Convection & Radiant Heat. Standing Pilot/Operates During Power Outages. Remote Control & Wall Thermostat Capable.
Technical Features	Honeywell Combination Gas Control Valve, Millivolt - VS8520E Pan Burner with Tuned Ports. Radiant & Fan Assisted Convection Heat.
Safety Test	Tested and certified by CSA to ANSI standards. Z21.88-1998 • CSA 2.33a - M98. Vented Gas Fireplace Heater
Heat Input	25,000 to 37,000 BTU's (Nat. Gas) 28,000 to 35,000 BTU's (Propane)
Ship Weight	200 lb.'s

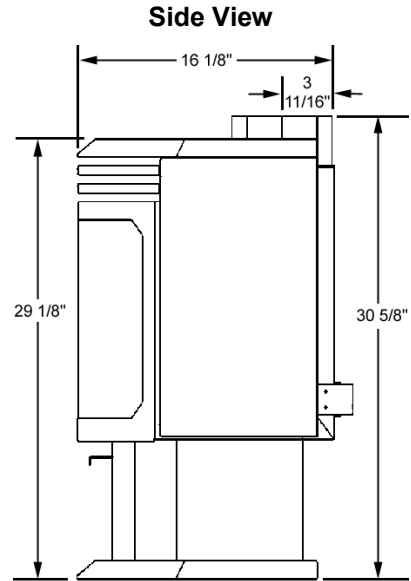
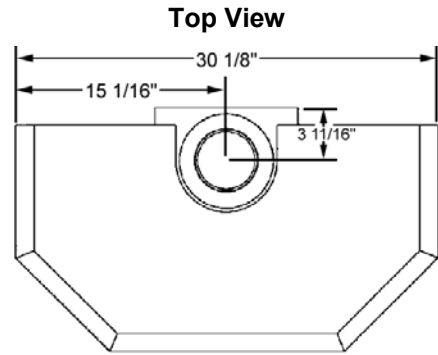

Dimensions shown are approximations only (+/- 1/4")

SPECIFICATIONS			
GAS TYPE	NATURAL GAS	PROPANE (LP)	MINIMUM CLEARANCES TO COMBUSTIBLES
Orifice Size	#31 -.120	#50-.070"	Back Wall Min.
Minimum Supply Pressure	4.5" WC	10.5" WC	Side Wall Min.
Maximum Supply Pressure	10.5" WC	13.0" WC	Corner (45° angle)
HIGH SETTING			<i>stove corner to wall, min.</i>
Manifold Pressure	3.5" WC	10.0" WC	(Floor to) Ceiling Height Min.
Input BTU/HR / ⊗ Efficiency	37,000/76%	35,000/79%	Alcove Min. Height
LOW SETTING			Alcove Min. width
Mainfold Pressure	1.8" WC	6.6" WC	Alcove - Max. Depth into
Input BTU/HR	25,000	28,000	<i>stove face to alcove opening</i>
♦ Altitude - U.S.A. 0-4,500 Ft. (0-1372M) No derating ♦ Altitude - Canada 0-4,500 Ft. (0-1372M) No derating * With the orifice, manifold pressure and input ratings shown above. For installation higher than altitudes shown above, reorifice per Gas Codes			⊗ The efficiency rating of the appliance is a product thermal efficiency rating determined under continuous operating conditions and was determined independent of any installed system.
This Appliance is equipped at the factory for the use with Natural Gas or Propane (LP). Appliances using propane must be field converted using the LP Conversion Kit supplied with appliance.			

SAFETY / LISTING LABEL (RATING PLATE)

Model Name: L30 DVF-2
 Vented Gas Fireplace Heater.
 Foyer au gaz à évacuation.



Serial Number
 No. de Serie

L30 DVF-2

**VENTED GAS FIREPLACE HEATER -
 NOT FOR USE WITH SOLID FUEL**
**FOYER AU GAZ À ÉVACUATION -
 NE PAS UTILISER AVEC OU COMBUSTIBLE SOLIDE.**



Gas/Gaz Type
 Natural
 Propane
 Controls: VS8520

Tested to: ANSI Z21.88a-2003
 CSA 2.33a-2003 Vented Gas Fireplace Heater

Natural Gas Model: L30 DVF-2
 Input (0-4500') 37,000 Btu/hr
 Steady State Efficiency 76%
 Output 28,120 Btu/hr
 Minimum Input 25,000 Btu/hr
 Orifice 31 dms
 Manifold Pressure 3.5" w.c./c.e.
 Min. Supply Pressure 4.5" w.c./c.e.

Natural Gaz Modele: L30 DVF-2
 Ailmentation (0-1370m)
 Efficacité de système transistorisé
 Production
 Pulsance minimum
 Grandeur de l'injecteur
 Pression a la tubular d'alimentation
 Pression d'alimentation minimum

Propane Gas Model: L30 DVF-2
 Input (0-4500') 35,000 Btu/hr
 Steady State Efficiency 79%
 Output 27,650 Btu/hr
 Minimum Input 28,000 Btu/hr
 Orifice 50 dms
 Manifold Pressure 10" w.c./c.e.
 Min. Supply Pressure 11" w.c./c.e.

Propane Gaz Modele: L30 DVF-2
 Ailmentation (0-1370m)
 Efficacité de système transistorisé
 Production
 Pulsance minimum
 Grandeur de l'injecteur
 Pression a la tubular d'alimentation
 Pression d'alimentation minimum

Electrical Rating 115 V; 60 HZ;
 less than 12 A.
 Power Consumption 100W

Alimentation Electrique
 Consommation d' énergie

Minimum Clearances to Combustibles -

Degagements Minimum Des Materiaux

Sidewall 12"/305mm
 Backwall 2"/51mm
 Adjacent Wall Corner 4"/102mm
 Ceiling 36"/914mm
 Vent Pipe to Wall Surfaces: Top 3"/76mm
 Sides 1"/25.4mm
 Bottom 1"/25.4mm

Mur Lateral
 Parole arrière
 Coln de parole adjacent
 Plafond
 Entre le conduit de ventilation et les
 surfaces murales

For use with Natural Gas and L.P. Gas (Propane). A conversion kit, as supplied by the manufacturer, shall be used to convert this room heater to the alternative fuel.
 Pour utilisation avec le gaz naturel et le propane. Une trousse de conversion fournie par le fabricant doit être utilisée pour passer d'un combustible à l'autre.
 This vented gas fireplace heater is not for use with air filters.
 Ne pas utiliser de filtre à air avec ce foyer au gaz à évacuation
 This appliance is only for use with the type of gas indicated on the rating plate and may be installed in an aftermarket, permanently located, manufactured (mobile) home where not prohibited by local codes See owner's manual for details. This appliance is not convertible for use with other gases, unless a certified kit is used.
 Cet appareil doit être utilisé uniquement avec le type de gaz indiqué sur la plaque signalétique et peut être installé dans une maison préfabriquée (mobile) installée à demeure si les règlements locaux le permettent. Voir la notice du propriétaire pour plus de détails. Cet appareil ne peut être converti à d'autres gaz sauf si une trousse de conversion certifiée est utilisée.
 For use with glass doors certified with the appliance only.
 Pour utilisation uniquement avec les portes en verre certifiées avec l'appareil.

Manufactured by Lennox Hearth Products, Burlington, WA

60020332 REV B

If the rating plate on the unit is different than shown here, the rating plate on the unit is the correct one.

OWNERSHIP RECORDS

Dealer's Name:

Dealer's Address:

City:	State:	Zip Code:
-------	--------	-----------

Serial Number:	Date of Purchase:	Date Installed:
----------------	-------------------	-----------------

Notes:

SERVICE AND MAINTENANCE LOG

Service Date	Service Technician	Service Description
--------------	--------------------	---------------------

--	--	--

--	--	--

--	--	--

--	--	--

--	--	--

--	--	--

--	--	--

--	--	--

--	--	--

--	--	--

--	--	--

--	--	--

--	--	--

--	--	--

--	--	--

--	--	--

--	--	--

NOTE: DIAGRAMS & ILLUSTRATIONS NOT TO SCALE.

LENNOX reserves the right to make changes at any time, without notice, in design, materials, specifications, prices and also for discontinued colors, styles and products. Consult your local distributor for fireplace code information.

Printed in U.S.A © LENNOX HEARTH PRODUCTS 2001
P/N 775,029M REV. B 08/2004

LENNOX[®]
HEARTH PRODUCTS

1110 West Taft Avenue • Orange, CA 92865