

INSTALLATION DOCUMENTATION	1/03/2006	Bike KIT	Suzuki GSX R K5-K6
Installation Manual: MXL kit for Suzuki GSX-R K5-K6 Version 1.02			750cc – 1000cc

MXL Pista / MXL Strada KIT FOR SUZUKI GSX R 2005-2006

The kit is intended only for those bikes completely following the service manual



MXL Strada Dash

It works like a dash with 6 already configured channels that show:

- RPM
- Speed
- Water Temperature
- Oil Pressure
- Fuel Level
- Turning Lights
- High Beam
- Engaged gear number

MXL Strada can also receive a beacon signal, records RPM, speed, water temperature and oil pressure max and min value and has **2 other free channels**

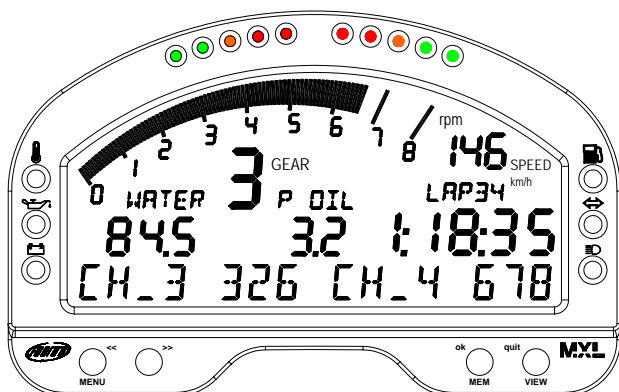

MXL Pista dash and data logger

It works both like a dash and like a data logger and has two configured channels. It shows:

- RPM
- Speed
- Water Temperature
- Engaged gear number

MXL Pista can also receive a beacon signal and has **6 free channels**.

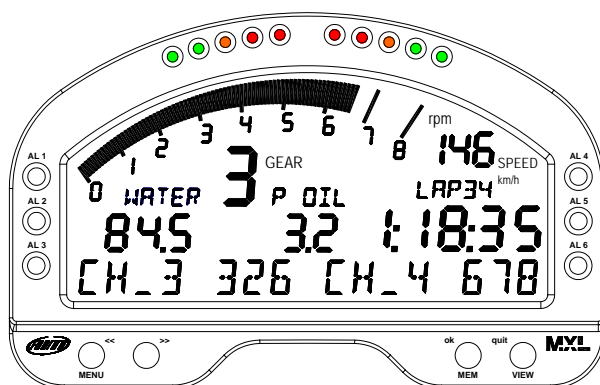



KIT DESCRIPTION

MXL Strada/MXL Pista kits are composed of the following objects:

MXL Strada kit

- **MXL Strada**
- Wiring for **MXL Strada**
- Installation kit with a dedicated bracket
- USB cable for Pc interface
- CD-ROM with **Race Studio 2** software
- Infrared beacon receiver and transmitter (optional)
- Documentation

MXL Pista kit

- **MXL Pista**
- Wiring for **MXL Pista**
- Installation kit with a dedicated bracket
- Infrared beacon receiver and transmitter
- USB Cable for PC interface and data download
- CD-ROM with **Race Studio 2** software
- Documentation

MXL(*) kit for **Suzuki GSX-R** has been developed for the **750 cubic capacity** model and for the **1000 cubic capacity** one.

Please note: if you have a Suzuki GSX-R 600 cubic capacity you should buy a Suzuki GSX-R 2004 plug and play kit.

(*) When you find **MXL** this means we are speaking of **MXL Pista** and **MXL Strada**. The aim of this kit is to merge the functionalities of the stock dash together with the ones of a professional data acquisition system.

MXL Pista / MXL Strada - Suzuki GSX-R version may be used both on track (lap times, split times, engine's parameters, gyroscope to map tracks; this last for "**MXL PISTA**" only) and on street (odometer, water temperature, oil pressure alarm, fuel level).

The gauge, as the stock dash, is powered by the bike's master switch. The gauge has to be connected to the standard head light using the bracket supplied with the system. The bracket is made in black anodized aluminum, in order to be lightweight and mechanically resistant.

We would moreover suggest you to keep your Suzuki GSX-R manual available while installing your MXL.



GENERAL NOTES – Read this before installing the system

- Do not cut any wiring: the wiring supplied with the kit is plug and play.
- Please, be careful not to damage the on-board connectors when plugging/unplugging them.
- Do not install the system when the engine is hot. The on-board connectors are quite near to the engine and you can burn yourself.
- The space under the gas tank is quite confined: be careful not to hurt yourself when plugging and unplugging the connectors. If necessary, please remove the gas tank in order to have a wider available space.
- Be careful not to loose screws and washers.
- Do not damage the fairing when installing/uninstalling it.

INSTALLATION STEP 1 – Removing mirrors, frontal and lateral fairing.

In order to be able to unplug the stock dash and to install your **MXL** on your **Suzuki GSX-R** we would suggest you to remove:

- the bike front transparent fairing
- the lateral mirrors
- the lateral fairings

Please refer to your bike user manual to know how to do so.

INSTALLATION STEP 2 – Removing the seat and the bike's gas tank.

In order to be able to reach the on board connectors (water, gear and TPS), you need to remove the bike seat and the gas tank.

Please refer to your bike user manual to know how to do so.

INSTALLATION STEP 3 – Removing stock dash; unplugging connectors

The third installation step consists in removing the stock dash and unplugging the “on-board” connectors.

The stock dash is fixed to your **Suzuki GSX-R** bike with three screws. **Figure 1** shows the bike without the stock dash. The three holes red circled and highlighted with a red/blue arrow in the **Figure** are these where the dash was fixed.

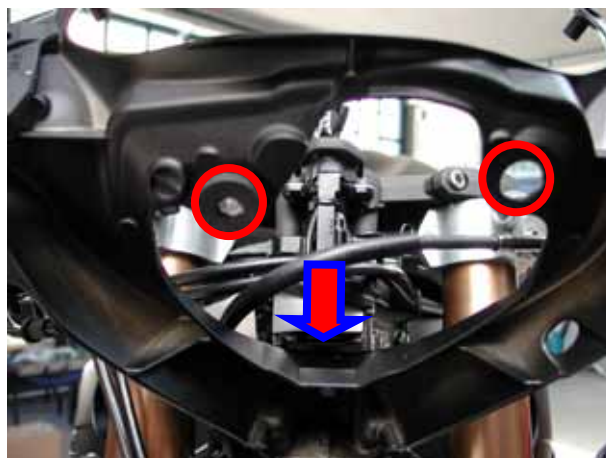

Figure 1: stock dash has been removed.

Once removed the stock dash, you have to unplug the AMP 16 pins connector from the dash backside.

As shown in **Figure 2**, please remove the protective plastic cover and, then, push down the locking tongue (highlighted with a red/yellow arrow) and pull out the connector from the dashboard.



Figure 2: unplugging the on board dash connector

Figure 3 shows the standard location of the Gear and Water temperature on-board connectors.

For further information concerning the “on-board” connectors, please see **Figures from 4 to 6**.

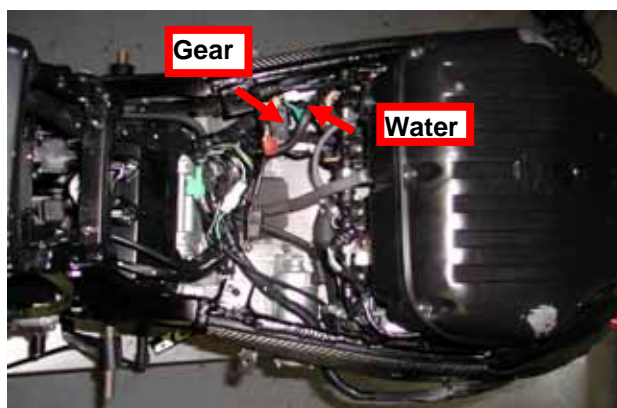

Figure 3: on board connectors – Water temp. / Gear

The on-board **Gear** connector, shown in **Figure 4** is a 3 pins / white coloured connector which is usually located on the bike's left side (as shown in **Figure 3**).

Here below is a drawing of both male and female GEAR connectors.

NOTE: cable colours correspond to the real ones.

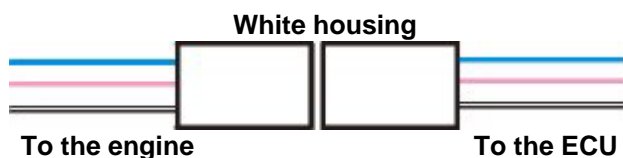

Figure 4: Gear connector – particular

The on-board **Water temperature** connector, shown in **Figure 5**, is a 2 pins / green coloured connector located on the bike's left side (as shown in **Figure 3**).

Here below is a drawing of the water temperature connector.

NOTE: cable colours correspond to the real ones.

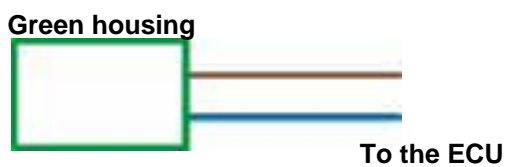

Figure 5: Water temperature connector – particular

NOTE: how to unplug 3 pins connectors

3 pins male/female connectors are firmly plugged together.

To unplug the male connector from the female, please use a flat corkscrew: push down the locking tongue and then unplug the 2 connectors.

Be careful: pull the 2 connectors by the housing and not by the wiring (you might seriously damage the wiring unplugging each cable from the 3 pins connector).



Figure 6: How to unplug a connector

INSTALLATION STEP 4 – Milling the chassis that supports the dash.

Due to the fact that lap stock connector is hidden behind the chassis that supports the dash, you need to mill a part of it to be able do connect lap cable to the related stock connector. In **Figure 7** is highlighted the part of the chassis you should mill.

Please be careful not to damage the silent block (highlighted with an yellow arrow) while milling the chassis.



Figure 7: the part of the chassis to milled.

INSTALLATION STEP 5 – Assembling the kit.

The fifth installation step consists in assembling the kit for **Suzuki GSX-R**.

1. The kit you receive, has already mounted the four anti-vibration mountings on the backside of your **MXL**;
2. Install your **MXL** on the aluminium bracket. The bracket has to be fixed to your **MXL** in correspondence of the 4 anti-vibration mounting and has to be fixed using 4 screws and 4 Grover washers.



Figure 8: anti-vibration mountings – particular

Figure 9 shows the correct assembly of **MXL**, bracket and washers (rear view)



Figure 9: MXL and bracket – rear view

INSTALLATION STEP 6 – Wirings connection.

The sixth installation step consists in installing the wiring supplied with the kit.

The wiring is all contained in a rubber girdle. Please bend down the wiring and let all the harnesses pass along the right side of the bike.

To correctly install the wiring, please follow these instructions:

1. Let all cables (except for “Lap” cable) pass between the head light and the front fairing chassis as in **Figure 11**.
2. Please note: 2 AMP connectors, wiring labelled “Lap” and “on-board input” wiring (the one ending with a black aluminium box), should remain up to the front fairing chassis. In particular, AMP connector and channels interface box are too big to pass between the chassis and the head light. We suggest to insert the wiring from the top.
3. Let “Gear”, “Water temp” etc... wirings run along the chassis, as in **Figure 12**. Please, use plastic wrappers to fix them to the bike’s stock wiring.
4. “Gear” and “Water temp” stock connectors are under the gas tank: let them enter the engine compartment, as highlighted in **Figure 12**.
5. “Gear” and “Ch.1 Water temp” cables have 2 connectors: a male and a female. Please, plug **AIM** male connector to stock female one and **AIM** female connector to stock male one.
6. Connect the 16 pins black connector to the male connector located inside the black aluminium box (push the connector till you hear a click). See **Figure 13** for further information.
7. Once the 16 pins connector has been plugged, use the plastic cover of the stock dash to make the connection waterproof.



Figure 10: Wiring installation



Figure 11: Kit installation



Figure 12: Wiring installation: run the wiring along the chassis



Figure 13: Wiring installation – particular of AMP connector



INSTALLATION STEP 7 – Installing the kit.

After having installed your **MXL** on the bracket, please fix the bracket to your bike chassis.

Before re-mounting the lateral fairing, the front fairing, the seat and the gas tank, we suggest you to turn on the bike in order to check the system's integrity and its correct installation.

FIRMWARE FOR MXL GSX-R – 2005

As your **MXL Suzuki** has been designed both for street and track use and as the information the driver wants to display are different for street and track use, your **MXL Suzuki** is equipped with a special firmware version which provides you with a **second virtual dashboard**.

When you are driving on a street, the display is set to “**street mode**” and shows the following parameters:

- RPM graphical bar: settable upper limit;
- RPM digital value / Battery voltage / Total odometer / Partial odometer / Current date and time: fuchsia colour (button **VIEW/QUIT** to switch between them);
- Speed: red colour;
- Gear number: green colour;
- 2 fixed analog inputs (not switch able): Blue colour
- 4 switch able analog inputs or static string: Light Blue colour.

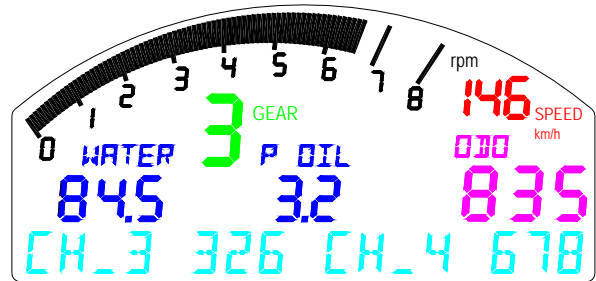

Figure 14: Street display

Once you start running on a track and your gauge triggers a lap (you pass in front of a switched-on lap transmitter), the display automatically switches to “**track mode**” and shows the following parameters:

- RPM graphical bar: settable upper limit;
- Lap time / RPM digital value / Battery voltage / Current date and time: fuchsia colour (button **VIEW/QUIT** to switch between them);
- Speed: red colour;
- Gear number: green colour;
- 2 fixed analog inputs (not switch able): Blue colour
- 4 switch able analog inputs or static string: Light Blue colour.



Figure 15: Track display

In order to step back from “**track mode**” to “**street mode**”, please switch off the gauge and then re-switch it on. The gauge sets automatically to “**street mode**”.

NOTE: for further information concerning the display management and its configuration, please refer to the **MXL Strada / Pista / PRO** user’s manual.

MXL PISTA / MXL STRADA SUZUKI CONFIGURATION [RACE STUDIO 2]

Your **MXL Pista / MXL Strada Suzuki** may be interfaced with the PC in order to:

- download the data stored in the internal memory;
- upgrade the gauge firmware;
- configure the gauge.

Once you buy a **MXL Pista / MXL Strada Suzuki**, the gauge already includes a configuration properly developed for your **Suzuki** bike: all sensors, calibration curves, engine parameters, speed parameters, etc... have already been set to a default value which allows you the possibility to plug in the input cable and start running.

Anyway, if you wish to change, for instance, the RPM upper value or the shift lights, if you wish to add a potentiometer sensor or a gyroscope on your **MXL Pista / MXL Strada Suzuki** and you need to calibrate them, if you change the crown or the pinion with a “different teeth number” one, you need to use our software **Race Studio 2**.

The CD-ROM including software, USB drivers, installation documentation and user manual is included in the **MXL Pista / MXL Strada Suzuki** kit. If you have any doubt about software or USB drivers installation, please refer to the installation manual included in the CD-ROM.

The following table shows the input channels for **MXL Pista / MXL Strada Suzuki**.

MXL Pista - Suzuki

Ch. 1	Water temperature
Ch. 2	Free input – use RS 2(*)
Ch. 3	Free input – use RS 2(*)
Ch. 4	Free input – use RS 2(*)
Ch. 5	Free input – use RS 2(*)
Ch. 6	Free input – use RS 2(*)
Ch. 7	Free input – use RS 2(*)
Ch. 8	“On board” gear sensor

MXL Strada - Suzuki

Ch. 1	Water temperature
Ch. 2	Free input channel – use RS 2 (*)
Ch. 3	Oil Pressure
Ch. 4	Free input channel – use RS 2 (*)
Ch. 5	Fuel Level
Ch. 6	Direction Lights
Ch. 7	High Beam
Ch. 8	“On board” gear sensor

(*) RS2 = **Race Studio 2** software

To correctly configure your gauge and use **Race Studio 2**, please follow these instructions.

Run **Race Studio 2** and select “**MXL**” pushbutton in the left vertical toolbar. Press “System manager” button and then “New” button: the screenshot shown in **Figure 16** is prompted.

Please, set all configuration parameters (Logger type, vehicle name, speed, temperature and pressure unit of measure, etc...) and then press OK button.



Figure 16: Race Studio 2 – New configuration

Once pressed OK button, System Manager window is prompted on your monitor, as shown in **Figure 17**.

To set a configuration channels, please select it among the available ones (in **Figure 17**, for instance, there are 3 available configurations: the yellow-highlighted is the selected one) and press button “Channels”.

The screenshot in **Figure 18** is prompted.

MXL Strada Suzuki:

The logger has 2 free channels, labelled CH. 2 and CH. 4. Clicking in the related cell (row “CH_2”/“CH_4” column sensor type) you can choose in a long list of pre-defined sensors or set a custom sensor selecting “custom sensor manager”.

MXL Pista Suzuki:

The logger has 6 free input channels, labelled from CH. 2 to CH. 7. Clicking in the correspondent cell (row “CH 2 / CH. 7” column “Sensor type”) you can choose in a long list of pre-defined sensors or set a custom sensor selecting “custom sensor manager”. Moreover, you may set channel name and sampling frequency.

Once all sensors have been correctly set, please press button “Configuration”.

Configuration window (**Figure 19**) allows the user to set shift lights and alarms threshold value, change unit of measure, to modify the speed parameters, etc...



Figure 17: Race Studio 2 – System manager window

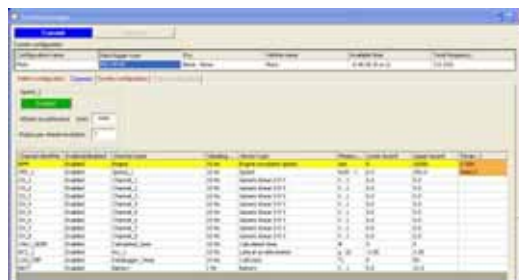

Figure 18: Race Studio 2 – Input channels window



Figure 19: Race Studio 2 – Configuration window

Speed:

The speed sensor on your Suzuki bike is installed on the jackshaft that connects the gearbox to the pinion. The number of magnets installed on this jackshaft is **4**.

The wheel circumference written in the proper cell is an “equivalent circumference” calculated using the following formula:

$$\text{Equiv Circumf} = \frac{\text{Wheel Circumf} * N_p}{N_c}$$

Np = Pinion teeth number
Nc = Crown teeth number

Using the default values for crown/pinion teeth number and wheel circumference for a **Suzuki GSX-R 750 2003-2004** the equivalent circumference is **801.4 mm (31.55 inches)**.

For your **Suzuki GSX-R 2005** bike equivalent circumference, we would suggest you to calculate this value. If you do not wish to do it manually, please refer to “[Equivalent circumference compute](#)” paragraph.

Shift lights:







You can modify the values inserted in the 5 cells to switch on the led at the desired RPM value. The 5 default values are the proper ones for a **Suzuki GSX-R 750 2003-2004**: for your **GSX-R 2005** you may need to modify such thresholds.

RPM:

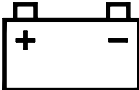

Please, DO NOT modify the “Multiply factor” (the default value is **/1**).

To change RPM scale upper limit, please select the desired value among the 7 default ones.

Alarm leds: MXL Strada Suzuki

AL 1		Water Temperature	Maximum Alarm. Default value: 90°C (194°F)
AL 2		Oil Pressure	Minimum Alarm Default value: 2 Bar (29 PSI)
AL 3		Battery voltage	Minimum Alarm Default Value: 13 V
AL 4		Fuel Level	Minimum alarm. Default value: 100 (corresponding to 4 litre – 1 gallon). Please do NOT modify the value: you might run out of petrol.
AL 5		Turn signals	Minimum alarm. Default value: 250 . Please do NOT modify the value: you might not see turn signal on display.
AL 6		High Beam	Maximum Alarm. Default value: 250 Please do NOT modify the value.

Alarm leds: MXL Pista Suzuki

AL 1		Water Temperature	Maximum Alarm. Default value: 90°C (194°F)
AL 2		Water Temperature	Minimum Alarm Default value: 50°C (122° F)
AL 3 to AL 6		You can set the proper threshold value of the sensor you have installed on each channel	

Gear sensor:

Suzuki kit allows you to sample the gear directly from an “on-board” sensor installed inside the gearbox. In order to allow your **MXL** to sample the gear, please do NOT modify the gear sensor default value which is set to **potentiometer**.

Calibrating auto-calibrating the sensors and transmitting the configuration:

MXL PISTA Suzuki owners:

If you have installed a gyroscope (to map tracks) and/or a fork travel potentiometer (or a rear shock travel potentiometer), these sensors have to be calibrated to sample correct data. Please, click on the “Calibrate” button: the screenshot shown in **Figure 20** appears.

The sensors are divided in 2 categories: the “to be autocalibrated” sensors and the “to be calibrated” ones.

The “to be autocalibrated sensors” are:

- Gyroscope
- Potentiometer distance

The “to be calibrated sensors” are:

- Zero based potentiometer
- Mid zero potentiometer

Please, refer to the user manual for further information about calibration / auto-calibration procedure.

Once finished calibrating / auto-calibrating the sensors, you have to transmit the configuration to the logger pressing the button “Transmit calibration” inside the “Sensor calibration” window.

Once you set the desired input channels on your **MXL Strada / MXL Pista Suzuki** and/or you set the desired threshold values for the alarm led of the shift lights, **you have to transmit the configuration to the logger: to do so, please press OK button and then “Transmit” button on the next screenshot.**

ATTENTION: before transmitting the configuration, the logger must be connected to the PC as shown in **Figure 21** and the USB drivers must be correctly installed. For further information concerning the USB drivers installation, please refer to the proper manual.

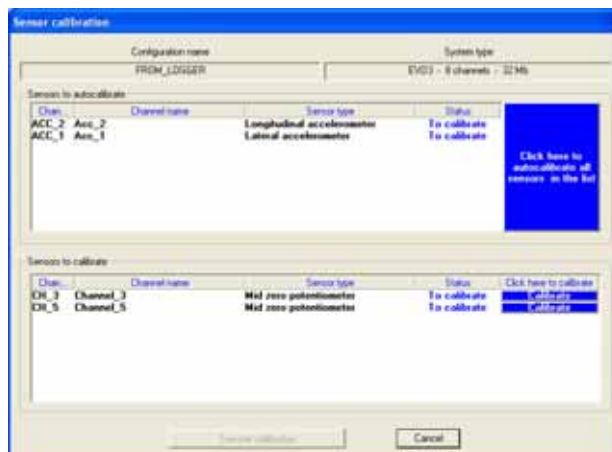

Figure 20: Race Studio 2 – Calibration window

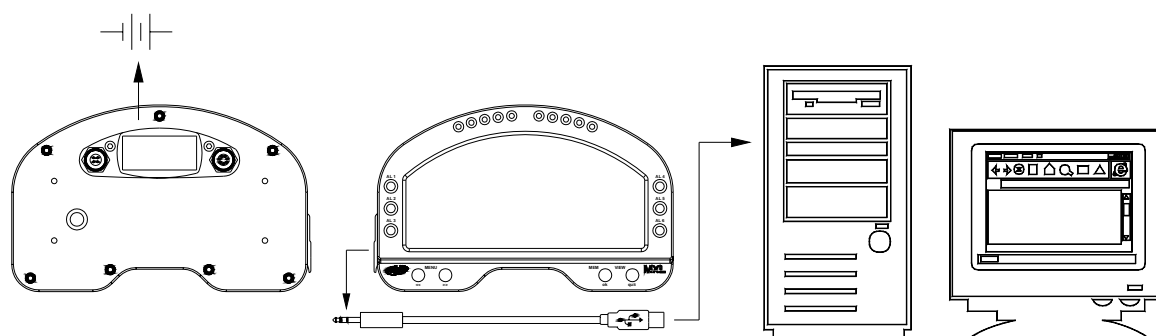

Figure 21: How to connect the logger to the PC

EQUIVALENT CIRCUMFERENCE COMPUTE

If you need to compute the equivalent circumference to be inserted in the correspondent “Configuration” window of **Race Studio 2** software, you can use “**Bike.exe**” software you find in **Race Studio 2** software CD. To do so please browse the Cd:

Double click on “**Bike.exe**” icon and the following window appears.

Please:

- insert “Drive gear teeth number”
- insert “Driven gear teeth number”
- select circumference unit of measure
- insert circumference value
- press compute button



The software computes the equivalent circumference and the final value appears in the related cell (red circled).



Please insert this value in the related cell of **Race Studio 2** Configuration window.



MXL PISTA / MXL STRADA SUZUKI MAINTENANCE

MXL Strada / MXL Pista SUZUKI GSXR kits do not need any special maintenance. Provided that adequate care is taken of display unit and component, the only required maintenance is periodical upgrading of software and firmware.

This installation manual has been written using the following parameters:

- **Software Version:** **Race Studio 2.20.16**
- **Firmware Version:** **MXL 14.45**

To check if new software/firmware versions have been published by **AIM**, please connect to our website www.aim-sportline.com and go to “software download” page where all last software and firmware versions are freely downloadable.

If you find a new software or firmware version, please download and run it and then follow the instruction prompted on your Pc monitor.



TABLE OF CONTENTS

KIT DESCRITPION	2
GENERAL NOTES – Read this before installing the system.....	3
INSTALLATION STEP 1 – Removing mirrors, frontal and lateral fairing.....	3
INSTALLATION STEP 2 – Removing the seat and the bike’s gas tank.	3
INSTALLATION STEP 3 – Removing stock dash; unplugging connectors	4
INSTALLATION STEP 4 – Milling the chassis that supports the dash.....	6
INSTALLATION STEP 5 – Assembling the kit.	7
INSTALLATION STEP 6 – Wirings connection.	8
INSTALLATION STEP 7 – Installing the kit.	9
FIRMWARE FOR MXL GSX-R – 2005.....	10
MXL PISTA / MXL STRADA SUZUKI CONFIGURATION [RACE STUDIO 2].....	11
<i>Speed:</i>	13
<i>Shift lights:</i>	13
<i>RPM:</i>	13
<i>Alarm leds: MXL Strada Suzuki</i>	13
<i>Alarm leds: MXL Pista Suzuki</i>	14
<i>Gear sensor:</i>	14
Calibrating auto-calibrating the sensors and transmitting the configuration:.....	15
EQUIVALENT CIRCUMFERENCE COMPUTE	16
MXL PISTA / MXL STRADA SUZUKI MAINTENANCE.....	17
TABLE OF CONTENTS	18