

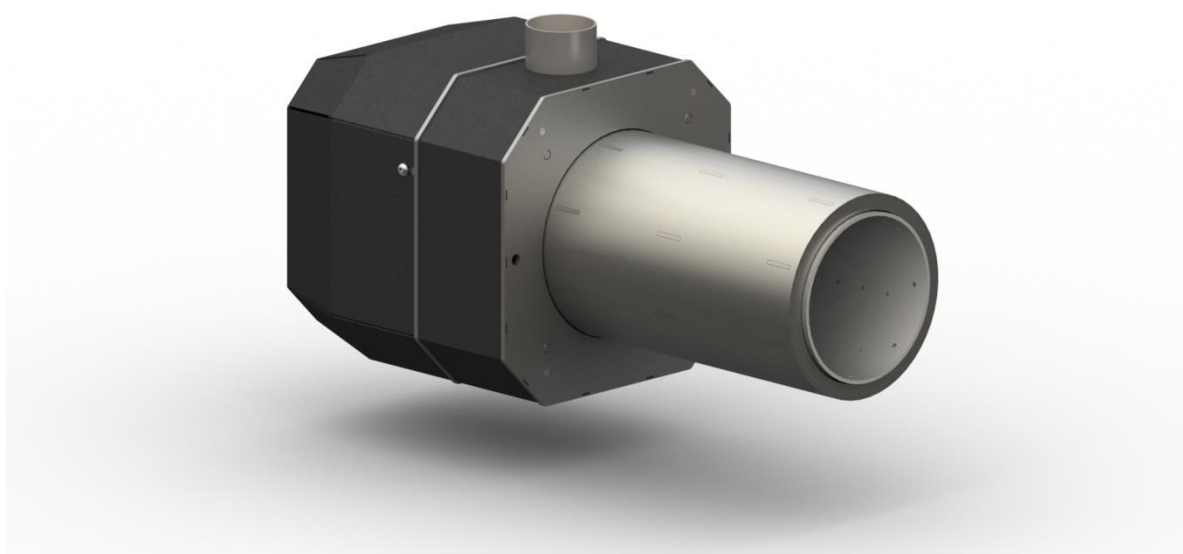

Service Manual

Unit: Pellet burner

Type: ROT-POWER



Models:

4-18 kW,

6-26 kW,

8-36 kW,

10-50 kW.

BTI GUMKOWSKI Sp. z o.o. Sp. k.
ul. Obornicka 71, 62-002Suchy Las
Phone +48 606-936-692, +48 61-811-70-37
biuro@kipi.pl

update: 10-04-2015

Contents

1.	Unit Description	3
2.	Fuel Specification.....	4
3.	Construction and Operation of the Burner.....	4
4.	Components.....	8
5.	Assembling the Unit.....	10
6.	Starting up.....	18
7.	Operation of the burner in the operational mode.....	18
8.	List of common problems.....	20
9.	Maintenance, adjustment and servicing the burner.....	21
10.	Operational Safety.....	33
11.	Burner Liquidation after its Service Life is Over.....	34
12.	Electric diagram.....	34
13.	Burner models, Overall and Mounting Dimensions.....	38
14.	Manufacturer's Initial Settings - Basic Operation Parameters.....	42
15.	Burner's technical data.....	43
	Declaration of Conformity	44
16.	Burner Installation Protocol.....	45
17.	Warranty.....	47
	Warranty Card	48

1. Unit Description.

Burners ROT-POWER series are designed for solid fuels combustion in the form of pellets with different degrees of pollution and grain size (according to this specification, point 2). The burner operates automatically and does not require supervision. Rotation of a combustion chamber prevents adhesion of slag to the chamber formed during combustion. The slag moves forward and exits the combustion chamber due to cyclic rotation. Moreover, no adhesion facilitates the cleaning process of the burner and significantly affects its service life. Combusted bed is oxygenated over the entire length of the combustion chamber, and further mixed by the rotating combustion chamber that enhances the combustion process and allows complete combustion of the supplied fuel.

The burner is designed to work with central heating boilers for solid fuels, as well as several models of gas or oil boilers with a combustion chamber enabling the collection and selection of ash.

The burner is an ecological device as it uses fuel from renewable sources. It also features a small demand for electricity.

The burner is equipped with a controller which is responsible for an optimal dosing of fuel in accordance with the parameters set by the user, and variable speed power control. This controller operates with a room thermostat which helps to maintain the temperature in the room. The burner's controller is also equipped with temperature sensors of the boiler and DHW. The controller can be connected to circuit pumps of central heating and DHW.

The burner is equipped with a safety fittings, which in the event of overheating or failure of the flame in the combustion chamber cut off the fuel supply. A break in electricity supply automatically turns off the fuel supply, and the amount remaining in the combustion chamber does not result in damage to equipment and cooperating devices.

The burner should be operated by power from an external storage tank for storing fuel, using a helical transport system, that is the fuel feeder tray.

The burner should only be supplied by fuel specified in point 2.

2. Fuel Specification.

The burner should only be supplied by fuel with the following properties:

Fractions	grain size
Diameter	6±1mm, 8±1mm
Length	3,15mm - 40 mm
Dust fraction	≤ 1%
Density	≥ 600 kg/m ³
Moistness	≤ 10%
Calorific value	16,5÷19 MJ/kg
Ash content	≤ 0,7%

Nominal power of the burners is given for the use of pellets produced in accordance with DIN or DIN Plus Specifications. For pellets with other combustion parameters, in particular with a different calorific value, ash level and moisture - the power of the burner may be different, usually smaller.

3. Construction and Operation of the Burner.

No.	Description
1.	Rotary combustion chamber
2.	Aeration chamber rotary
3.	Thermal insulation (option)
4.	Bearing of the aeration chamber and the combustion chamber
5.	Blower chamber
6.	Connection elbow for pellet feeding
7.	Flexible pipe connector - meltable
8.	External tray fuel feeder
9.	External fuel tray (option)
10.	Fan
11.	Mechanism for combustion chamber rotation
12.	Fuel feeder into the combustion chamber (stoker)
13.	Igniter

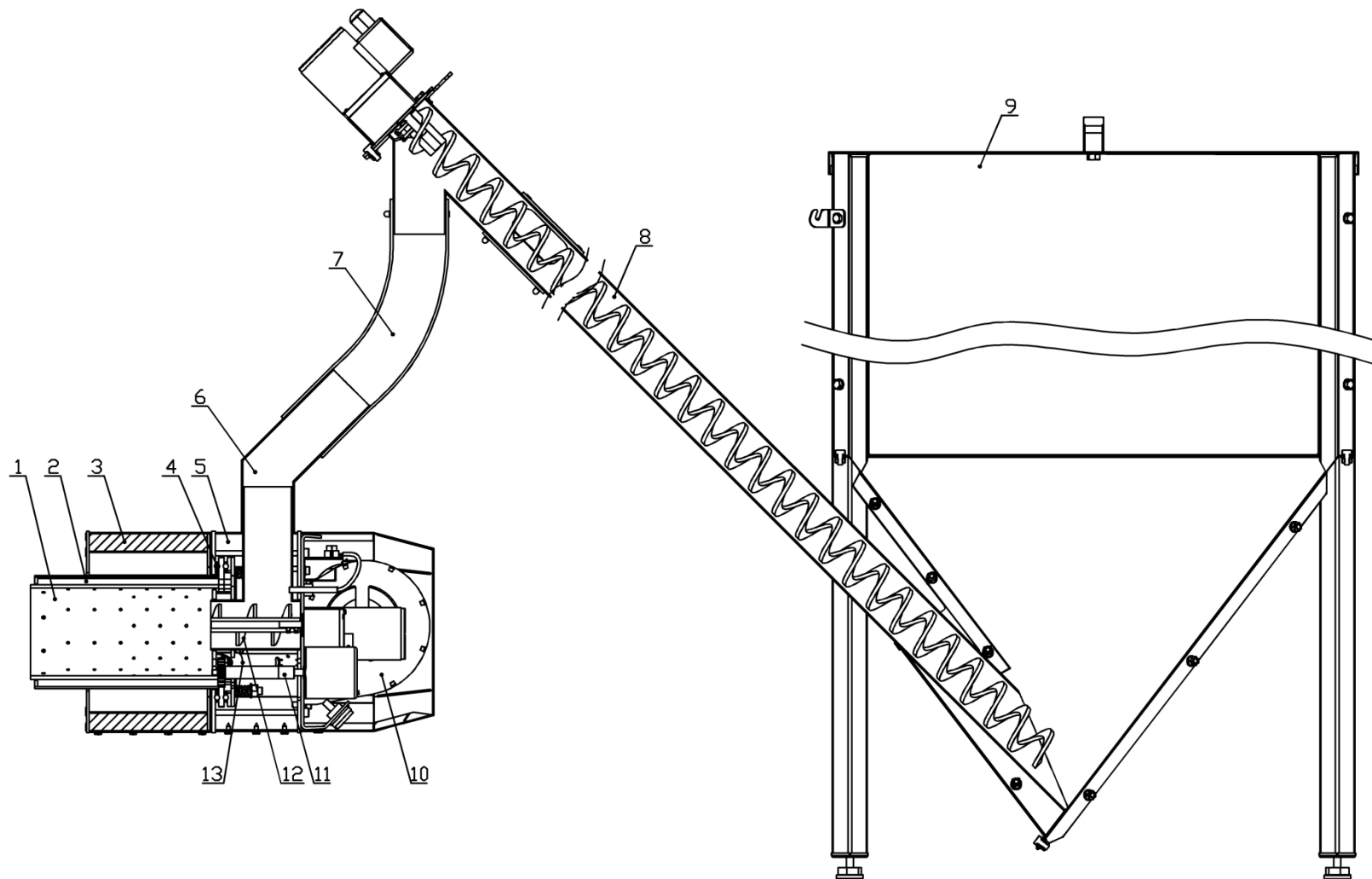

Fig. 1. Block diagram of the burner.

Construction and Operation of the Burner.

ROT-POWER burner is built with connected modules and metal sheet components. Components exposed to high temperatures are made of stainless and heat resistant steel, other elements are protected against external factors by galvanic coating or painting. External fuel feeder (5) is made of stainless steel tube.

The burner consists of the essential elements specified in the schema.

The burner starts the operation by fuel supply from the external tray (9) by an auger feeder (8) elastically connected with the burner. Then the amount of fuel is supplied by the auger feeder (12) into the combustion chamber (1). After delivery of the appropriate amount of fuel, the igniter (13) initiates ignition. After the ignition burner goes into continuous mode in accordance with the specified external parameters. The air necessary for the combustion of the fuel is supplied by fan (10) via the blower chamber to the combustion chamber, and some portion of air is also supplied via this chamber to the igniter. The air intake to the burner is located in the bottom part. During the operation, drive (11) causes the cyclic rotation of the of the combustion chamber including the outer tube (2). The frequency of rotation is adjustable. Combustion products move to the front of the burner and exit it, then accumulate in the ash pan of the connected central heating boiler or other boiler adapted to work with the burner.

Burner is fully automatic and adjustable. Fuel is automatically drawn from the tray, depending on the demand for thermal power. In the event of exceeding set limits burner goes into standby mode. The transition from standby mode to operating mode is also automatic, the burner goes into ignition mode and then again in the continuous mode. The intake air quantity is closely related to the amount of fuel delivered for optimum combustion and does not cause an excessive cooling of the combustion chamber. Operation of the burner is based on providing an appropriate amount of fuel and on periodic removal of combustion products, i.e. ash from the boiler ash chamber.

The burner is equipped with security features that protect it and the central heating boiler against overheating and other risks that may arise during the operation. The first is a photocell, which is responsible for detecting the presence of the flame. When the flame is absent, the burner switches its ignition mode, i.e. a small amount of fuel is provided and the igniter is triggered; the firing mode lasts for 2 minutes, when the ignition fails - the operation is repeated 3 times. After an unsuccessful ignition, the controller will display alarm message, further work is not possible until the error is cleared. The second safety element is a temperature sensor placed in the blower chamber, which breaks fuel supply from the main feeder in case of igniting the fuel dose inside the auger feeder that supplies fuel to the combustion

chamber; its triggering temperature is 90 °C. It is a constant alarm, which may be removed only by the user. Another safety element is the structure of the fuel delivery system - the use of two augers (the first extracts fuel from the external tank and the second supplies the fuel into the combustion chamber inside the burner) connected by a flexible (meltable) plastic hose which divides the stream of the supplied fuel. If the flame is drawn back from the burner, it will not ignite the fuel accumulated in the container. The last element of the protection system includes temperature sensors of the central heating boiler. The first sensor is used for continuous measuring the boiler temperature - when the set temperature is exceeded (boiler cooling temperature) the controller will attempt to lower the temperature of the boiler by discharging the excessive heat to the hot water container and by activating mixer servo-motors. When the temperature drops by 10 °C, the controller returns to normal operation. When the temperature does not drop after reaching critical temperature of 95 °C - STB temperature sensor is triggered – it operates even in case of power failure or in case of controller failure. Restarting the burner is only possible after resetting the button in the housing of the sensor controller. You must determine the cause of this error.

4. Components.

The burner is supplied with the following components:

No.	Components
1.	Burner ROT-POWER
2.	Controller (driver) from Plum
3.	The auger feeder from the external tray to the burner (operational length: 1,85 m with an extension option),
4.	Flexible hose (meltable) - length: 0.75 m for connecting the burner with the auger feeder,
5.	Elbow connection
6.	Emergency mechanical sensor for boiler temperature with wiring (type: STB),
7.	Central heating boiler temperature sensor with wiring,
8.	DHW temperature sensor with wiring,
9.	Optional thermal insulation of the outer pipe (aeration pipe).

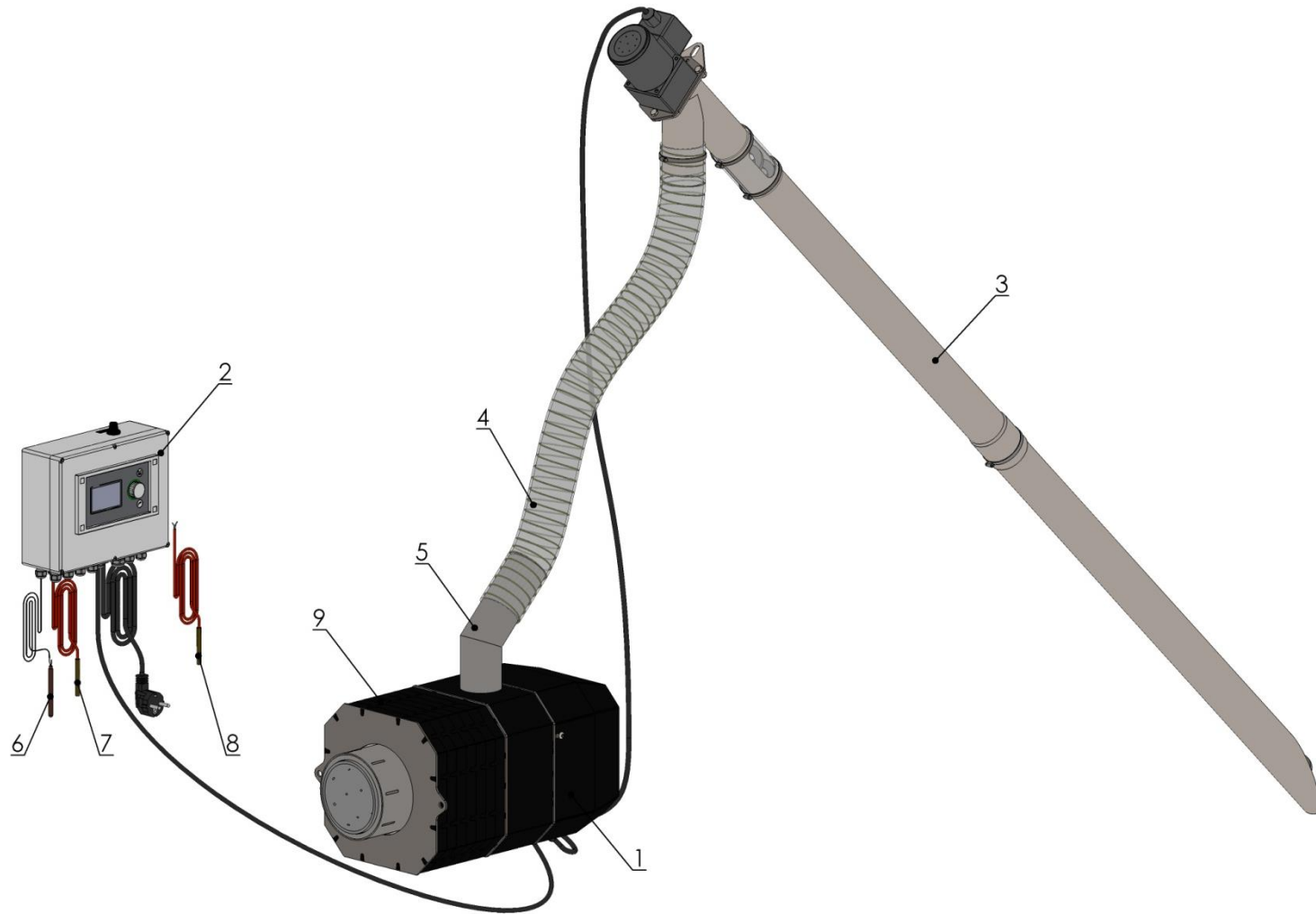

Fig. 2. Components of the set

5. Assembling the Unit.

Usually, the ROT-POWER burner is connected to the already working installation of the boiler. Depending on the design of the boiler, the connection is mounted to the furnace door. The burner must be placed in a location that allows easy access to the burner and enables installation to the boiler door. This solution provides easy cleaning and a possible review of the hearth. In the event of too small width of the door, the burner shall be mounted asymmetrically - closer to the hinges. When this operation is insufficient - use a spacer plate or insulating jacket with the mounting plate, to provide a distance with adjusting step. Exact mounting dimensions are specified in section 5.1.

Depending on the type of door closing (sealing) design - take measurements to analyse whether opening of the door would interfere with the burner.

It is also possible to mount the burner to the custom door/side of the furnace – but when it is needed - consult it with a service technician and the manufacturer.

The burner must be connected to the pellet tray, which may be purchased from the manufacturer of the burner or you may use another tray made of non-combustible material, which enables you to connect to the auger feeder (ø60 pipe) - observe the installation instructions in sec. 11-14. Pay particular attention to the bottom of the feeder where the feed screw/auger is present - it must be fully covered by the fuel and protected against hand contact during the operation. The rotating auger may cause injuries.

Burner installation should be performed by the service technician authorized by the manufacturer. Installation work should be completed with an installation and commissioning protocol.

5.1. Assembly Instructions.

1. Take the measurement of boiler door dimensions and determine the optimal point of attachment of the burner.
2. The burner must be placed in the central heating boiler or in other heat exchanger, maintaining dimensions shown in the following diagram and table. Make a hole for the outer tube of the burner and mounting holes for attaching burner to the boiler door.
3. Perform the mounting holes in the door according to specifications for particular burner.
4. If required, use the spacer plate or the insulating jacket.

5. Remove the outer casing of the burner by unscrewing the screws.
6. Mount the burner in the door using screws.
7. Depending on the selected option connect temperature sensors, DHW, room thermostat to proper controller clips (see wiring diagram) - guiding the cables through the glands in the housing.
8. Depending on the selected option connect the central heating pump and DHW pump proper controller clips (see wiring diagram) - guiding the cables through the glands in the housing.
9. Install the burner housing, and tighten the screws.
10. Boiler controller must be installed according to the manufacturer's instructions provided with the controller.
11. Place the pellet tray next to the boiler, insert the fuel feed conveyor and hang by the handle beside the auger drive.
12. Ground all metal parts connected to the igniter and carry out effectiveness measurement of grounding and zeroing.
13. Put the elbow connection on the burner, and connect the elbow with the fuel feeder using a flexible hose. Flexible pipe length can be adjusted by sliding it forward and backward on the combined elements. Keep the angle of decline in consumption of no less than 45° .
14. Connect the power cord of the fuel feeder into the appropriate slot in the burner.
15. Plug the multi-pin circular connector from the controller to the burner - pay attention to correct positioning of the plug, secure it with the nut.
16. Connect the electrical cord of the controller to a grounded electrical outlet.
17. Fill the tank with fuel.

Burner 6-26 kW:

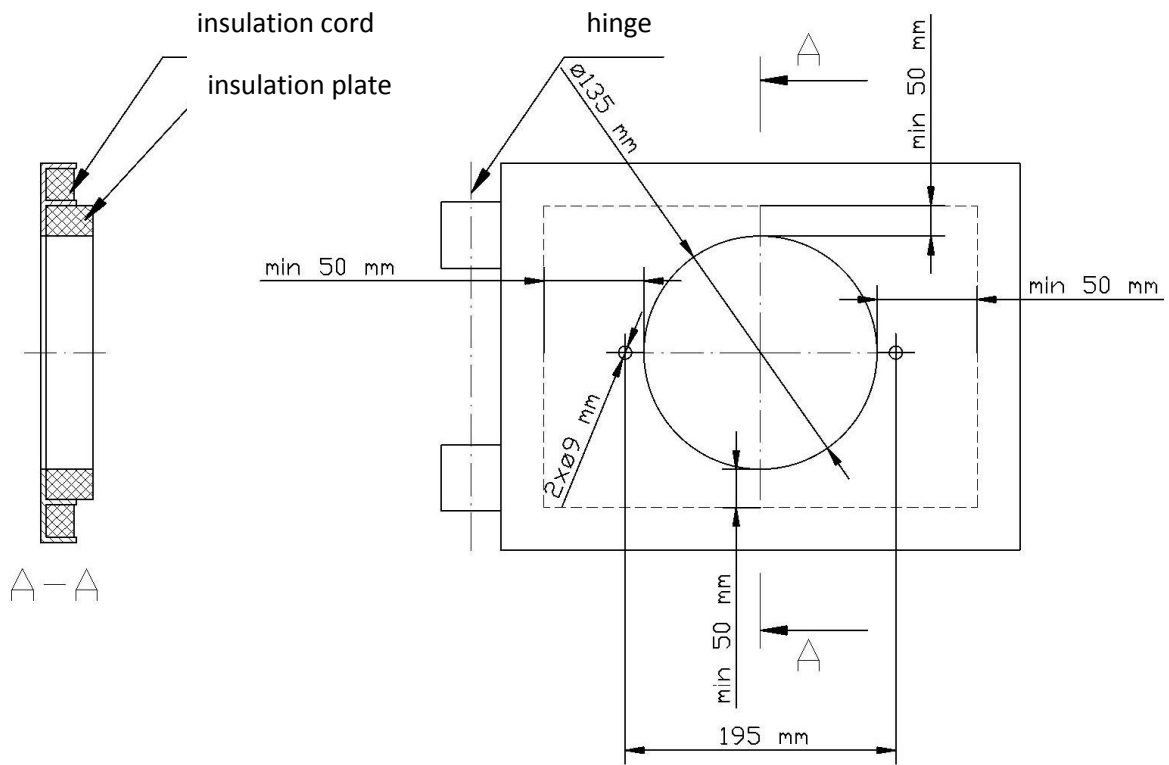

Fig. 5. Layout of mounting holes in burner 6-26 kW.

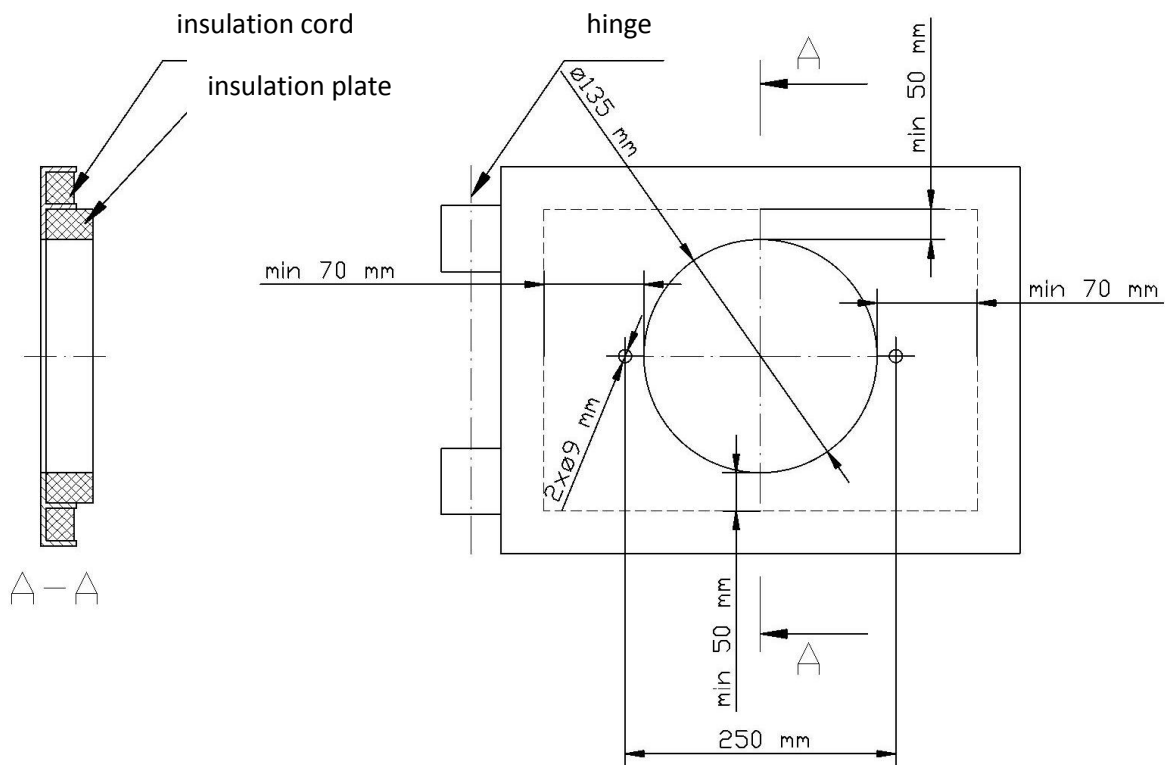

Fig. 6. Layout of mounting holes in burner 6-26 kW, including the insulating jacket and the mounting plate.

Burner 10-50 kW:

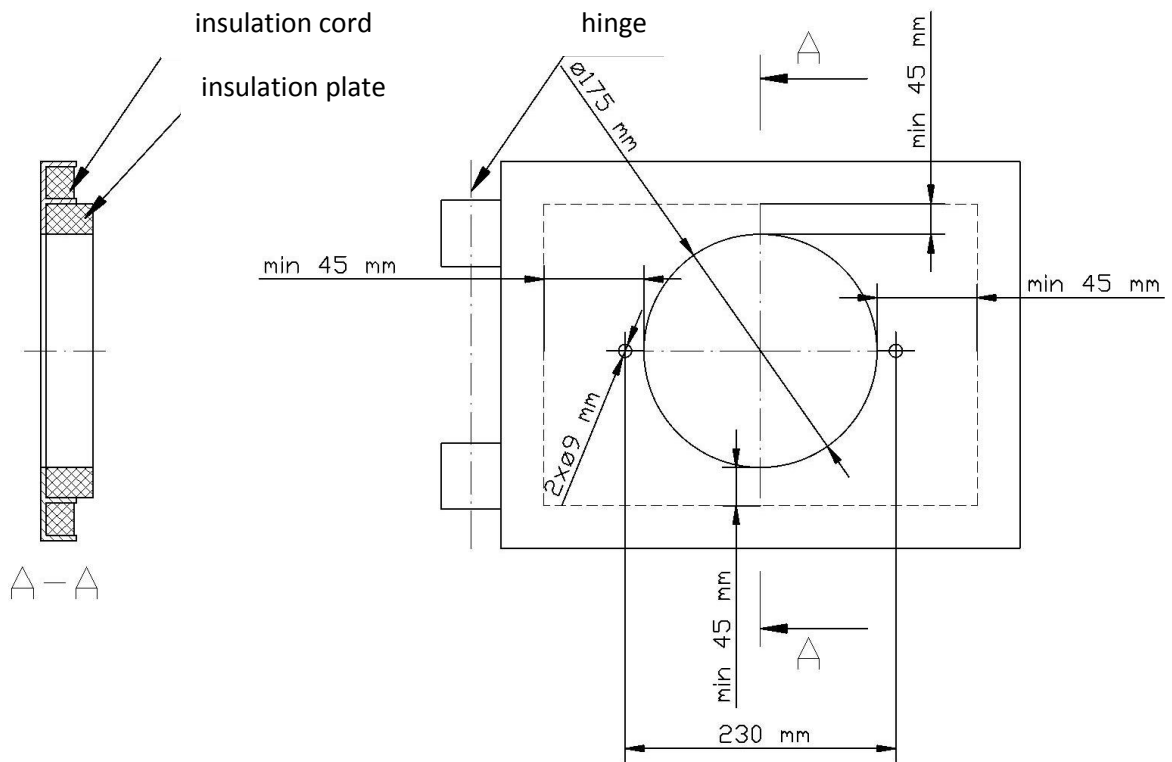

Fig. 9. Layout of mounting holes in burner 10-50kW.

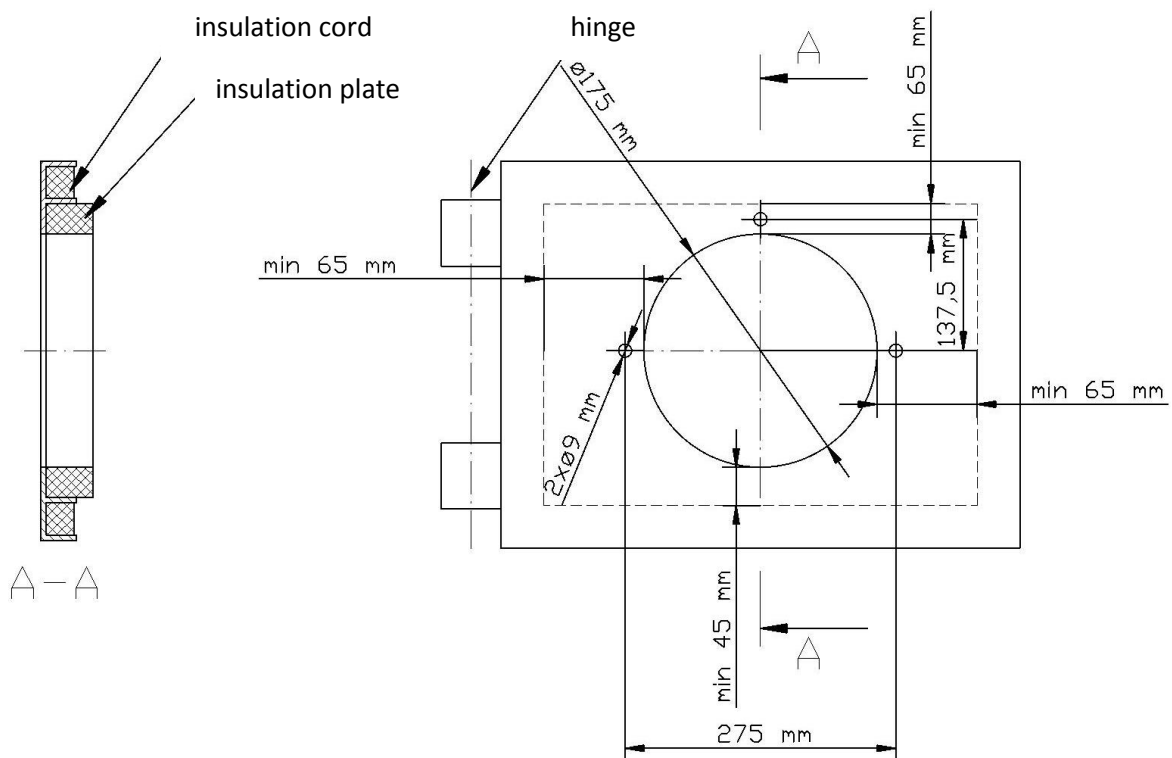

Fig. 10. Layout of mounting holes in burner 10-50 kW, including the insulating jacket and the mounting plate.

Required size of the furnace chamber.

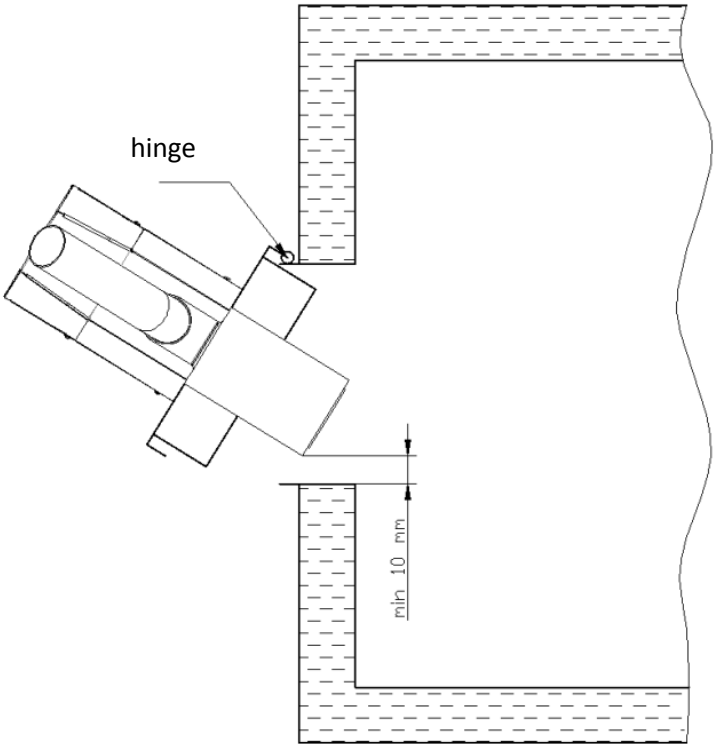

Fig. 11. Top view of the furnace chamber.

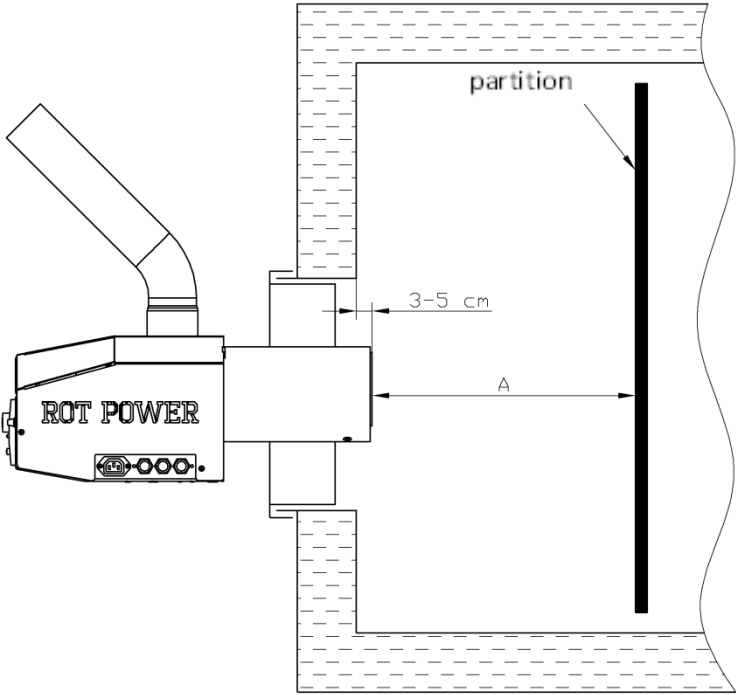

Fig. 12. Side view of the furnace chamber.

Power range [kW]	"A" - minimum distance [cm]
4-18	25-35
6-26	
8-36	
10-50	35-45

After connecting and starting the burner, the technician should train the user for the correct operation of the device, refer to possible controller settings and behaviour in case of an emergency and how to eliminate it.

The boiler room should meet certain conditions regarding the safety and protection of fire protection. In particular, there should not be stored flammable materials and substances. The ventilation system should meet the minimum requirements specified in the following table:

Power range [kW]	Cross section of the air supply [cm ²] (Diameter [cm])	Cross section of the exhaust air cord [cm ²] (Diameter [cm])
up to 30	200 (ø16)	200 (ø16)
30-60	300 (ø20)	200 (ø16)
60-2000	5 cm ² per 1 kW of power, not less than 300 cm ²	equal to at least the mid-section of the supply cable, not less than 200 cm ²

Position of the central heating boiler in the boiler room shall be in accordance with the guidelines specified in the boiler manufacturer's instructions. Leave at least 30 cm of free space around the burner; More space will facilitate maintenance and cleaning the burner and removal of ash from the device. Leave at least 10 cm of free space under the burner - to avoid blocking the air inlet of the fan. Pellet tray should be positioned at least 15 cm away from the boiler and at least 10 cm from the walls. In this case, consider the location of the tray to ensure easy refuelling.

The central heating should be filled in the required range - i.e. should have appropriate pressure and the value shall be specified in the boiler's instruction manual. This installation should be vented.

It is forbidden to use the igniter without safety guards.
--

6. Starting up

1. Check the level of fuel tank - refill if necessary.
2. Fill the fuel feeder (5), until the fuel begins to pour into the burner. To enable this function, press "MENU" button in the controller, then select "Manual operation" function and press the knob of this option; from in this sub-menu select "feeder", press the knob - "OFF" message will change into "ON" - at this point the external fuel feeder will activate - the filling mode lasts for 2 minutes, if the feeding tube s not filled-up, the operation must be repeated. At any time you can stop filling pressing the knob. You may exit the filling mode by pressing "EXIT" button.
3. All controllers connected to the driver should be set to their maximum values or shorted (default setting).
4. Press "MENU" button, to set the operational parameters of the burner and boiler. All settings and operating parameters are described in the accompanying user manual of the controller.
5. Press the knob of the controller and select "YES" - the controller will be activated.

7. Operation of the burner in the operational mode.

After completing the steps specified in sec. 6, the burner may operate in its continuous operation mode. As long as fuel is in the fuel tank and no emergency condition is present, filling the auger feeder with fuel is not necessary. Set the room thermostat to the desired operating mode.

After switching the controller, as described in sec. 5 of chapter 6 - the controller enter standard operation mode. Depending on the set parameters and operation status of the sensors, the controller will operate in the following modes - displaying appropriate messages.

Operating modes	Description
FIRING	Automatic firing-up of the furnace.
OPERATION	The burner operates with nominal power. Fuel is supplied automatically.
CONTROL	The burner operates at low power to keep the furnace burning. This mode is activated automatically after the pre-set parameters are achieved. The default time for this mode is 30 minutes.
DAMPING	This mode is used for damping (extinguishing) the burning of fuel residue.
STAND-BY	In this mode, the boiler and burner are off. The stand-by mode is automatically terminated after receiving the restart signal (e.g. temperature drop on the boiler).

The first step includes activation of the fan, which initially blows-through the combustion chamber. Then the fuel feeder is activated to dose fuel needed to fire up the furnace. After the fuel is dosed, the igniter is activated to ignite the supplied fuel. Firing time may vary, as it depends on the fuel type. It usually takes 1-3 min. The display shows message "FIRING". When the supplied dose of the fuel lights up - i.e. the value of the parameter measured by the photodetector reaches the pre-set value - the firing mode ends and the burner will enter the automatic operation mode - the display will show "OPERATION" message. When the light intensity inside the combustion chamber drops, i.e. the furnace is quenched - the burner will restart the firing mode. After reaching the limit parameters (i.e. boiler temperature, the temperature set at the room thermostat), the controller enters "CONTROL" mode and then the mode which depends on current indications of sensors, as described in the table.

Burner operation is prohibited when the rotation of the combustion chamber is disabled.

8. List of common problems.

No.	Fault	Reason	Remedy
1.	Burner does not ignite Message: "Ignition failure"	No fuel in the tank	<ul style="list-style-type: none"> – Fill up the tank with fuel – Carry out the procedure of filling the feeder - Section 6.2 – Clear the error by pressing the knob
		Fuel feeding augers are blocked	<ul style="list-style-type: none"> – Remove the blocking element
		Faulty igniter	<ul style="list-style-type: none"> – Contact the customer service of the Manufacturer
		Drives of feeding augers are damaged	<ul style="list-style-type: none"> – Contact the customer service of the Manufacturer
		Slag in the furnace	<ul style="list-style-type: none"> – Clean the combustion chamber
		Photodiode damaged or dirty	<ul style="list-style-type: none"> – Clean the photodiode – In case of damage, contact the customer service of the Manufacturer
		Slag or ash in the combustion chamber of the central heating boiler - at the level of the burner combustion chamber	<ul style="list-style-type: none"> – Clean the central heating boiler combustion chamber.
2.	Alarm: "Feeder maximum temperature exceeded"	Excessive temperature rise on the burner housing, which results by flame backfiring from the combustion chamber (default 90°C)	<ul style="list-style-type: none"> – The controller automatically enters the furnace quenching mode. The alarm may be deleted only by the user.
		Insufficient chimney draft.	<ul style="list-style-type: none"> – Verify the value of the chimney draft and take necessary action in order to increase it.
		Slag or ash in the combustion chamber of the central heating boiler - at the level of the burner combustion chamber	<ul style="list-style-type: none"> – Clean the central heating boiler combustion chamber.
3.	Alarm: "Feeder temperature sensor damaged"	Housing temperature sensor damaged	<ul style="list-style-type: none"> – Contact the customer service of the Manufacturer
4.	Alarm: Maximum boiler temperature exceeded	Boiler set temperature is exceeded.	<ul style="list-style-type: none"> – Wait until the water temp. drops below the preset temp. – Clear the error by pressing the knob
		Setting of the boiler operating temperature is too low	<ul style="list-style-type: none"> – Increase the boiler operating temperature, as specified in the

			boiler manual
		Boiler critical temperature is exceeded (95 °C) – STB sensor triggered	<ul style="list-style-type: none"> – You must determine the cause of this error. – Clear the error by pressing the button on the controller housing
5.	Alarm: "Boiler temperature sensor damaged"	Boiler temperature sensor damaged	<ul style="list-style-type: none"> – Contact the customer service of the Manufacturer
6.	The fan does not stop after the burner is quenched	Photodiode damaged or dirty	<ul style="list-style-type: none"> – Clean the photodiode – In case of damage, contact the customer service of the Manufacturer
7.	The burner is smoking	The amount of air fed into the combustion chamber is too low	<ul style="list-style-type: none"> – Clean the furnace
		The air inlet to the burner is covered/obstructed	<ul style="list-style-type: none"> – Clean the burner air inlet located in the bottom part of the burner
		The fan is damaged	<ul style="list-style-type: none"> – Contact the customer service of the Manufacturer
8.	Too much slag in the furnace	Incorrect fuel type	<ul style="list-style-type: none"> – Use fuel recommended by the manufacturer
		The rotating drive of the combustion chamber is damaged	<ul style="list-style-type: none"> – Contact the customer service of the Manufacturer

Any maintenance work requiring changes in the burner or auger feeder must be carried out after disconnecting the burner from the power supply and cooling down the burner.

9. Maintenance, adjustment and servicing the burner.

Maintenance must be strictly performed on cooled down burner disconnected from the power source.

9.1. General guidelines.

In order to ensure trouble-free operation, as well as to extend the life of the burner, the following steps should be applied:

1. The hearth should be kept clean - through its regular cleaning. The frequency of cleaning depends on the quality of the fuel, its ash content and humidity, as well as the

burner switching frequency and the dimensions of the combustion chamber / ash chamber. On average, it should be performed once a week.

2. Use only the fuel recommended by the manufacturer.
3. It is not allowed to burn in the burner materials not intended for the burner.
4. Provide adequate amount of fresh air.

9.2. Cleaning the tubular blower chamber.

During the operation of the burner, some combustion products may escape through the vent holes in the furnace tube to the space between this tube and the outer tube. Depending on the type of fuel used, cleaning of this component should be made approximately every 6 months. In order to remove them, follow the instructions below:

1. Disconnect from the burner the power supplying power to the external feeder and the controller cable.
2. Open the boiler door, in order to get access to the furnace tube.
3. Loosen the fixing screws (6) that secure the burner housing - 2 pcs.
4. Remove the burner housing (9).
5. Unscrew the fixing screws (7) - 4 pcs.
6. Carefully remove the plate with drives and fan (8).
7. When removing the plate (8) remove also igniter (12) from its slot.
8. Put aside the removed assembly in a safe place, paying particular attention to the igniter.
9. Locate and remove screw (5) and when its setting prevents loosening - manually rotate the outer tube (1) in "Z" direction.
10. Turn tube (1) in the direction indicated by "O" in order to remove it.
11. Remove tube 1 and 2 from the burner.
12. Clean the removed tubes, if necessary, clean the vent holes in tube 2.
13. After cleaning the tubes, you may start installing the burner.
14. Place the combustion tube (2) in tube (1) - ensure that the driver (4) is placed in the rib (3) with an undercut.
15. Attach both tubes to the burner, matching hooks of the tube (1) with grooves (11).
16. Turn firmly the tubes in "Z" direction.
17. Set the tubes in a manner allowing you to tighten the screw (5).
18. Tighten screw (5) - it is important that it is next to the rib of tube (1) and that it is tightened to the end.

19. Mount the plate with drives (8), during this step placed the igniter (12) in its slot, pushing it firmly to the screen plate. The undercut (10) in the drive shaft must match the undercut in the shaft of the drive motor - you may rotate the drive shaft by turning the tube (1) in "Z" direction. The temperature sensor (13) should match the slot in the tee connector of the fuel supply. Tighten screws (7).
20. Replace the housing (9).
21. Tighten screws (6).
22. Close the boiler door.
23. Connect cables disconnected in par. 1.
24. The burner is ready for operation.

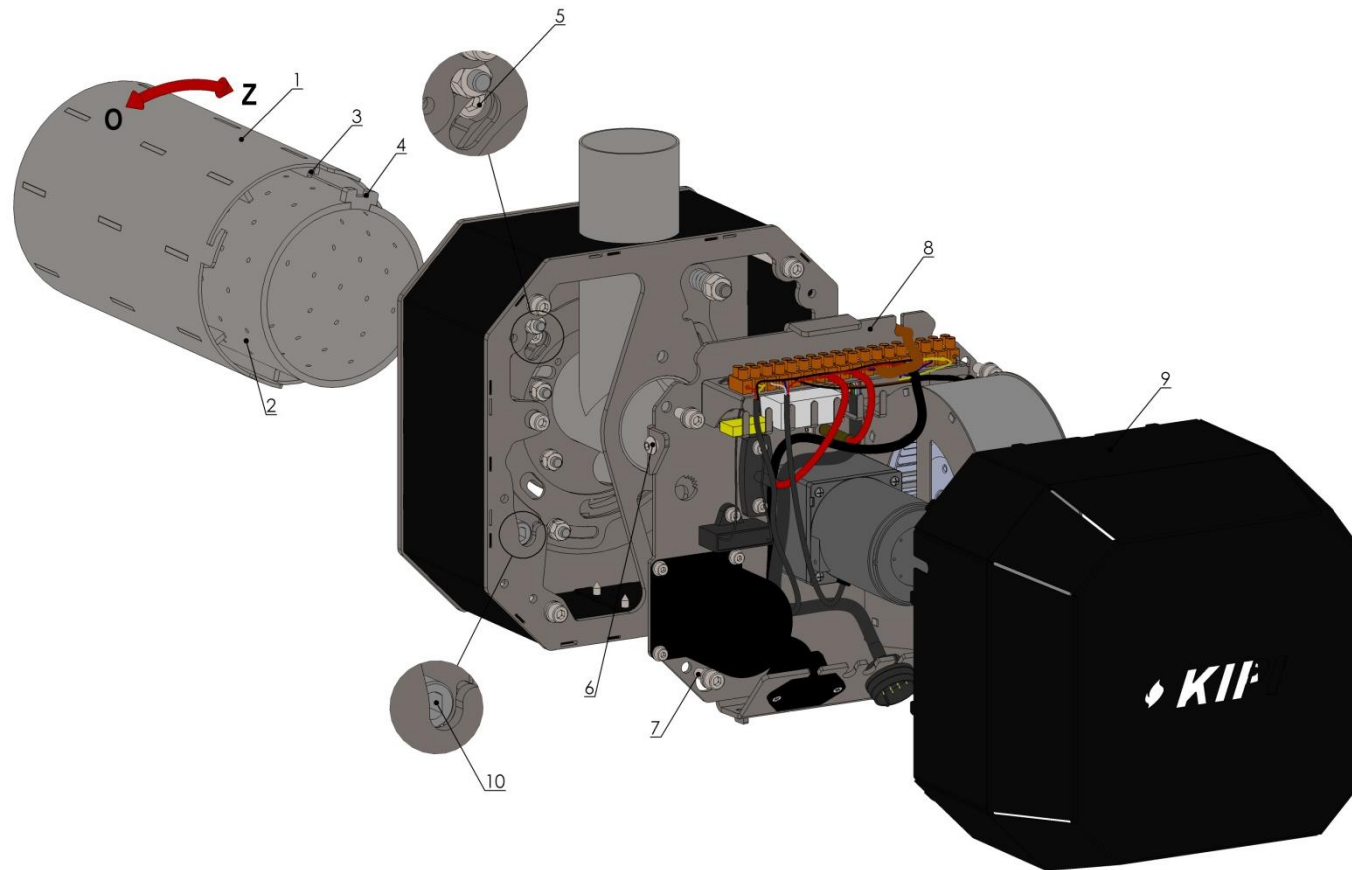

Fig. 13. Cleaning the tubular blower chamber – view 1.

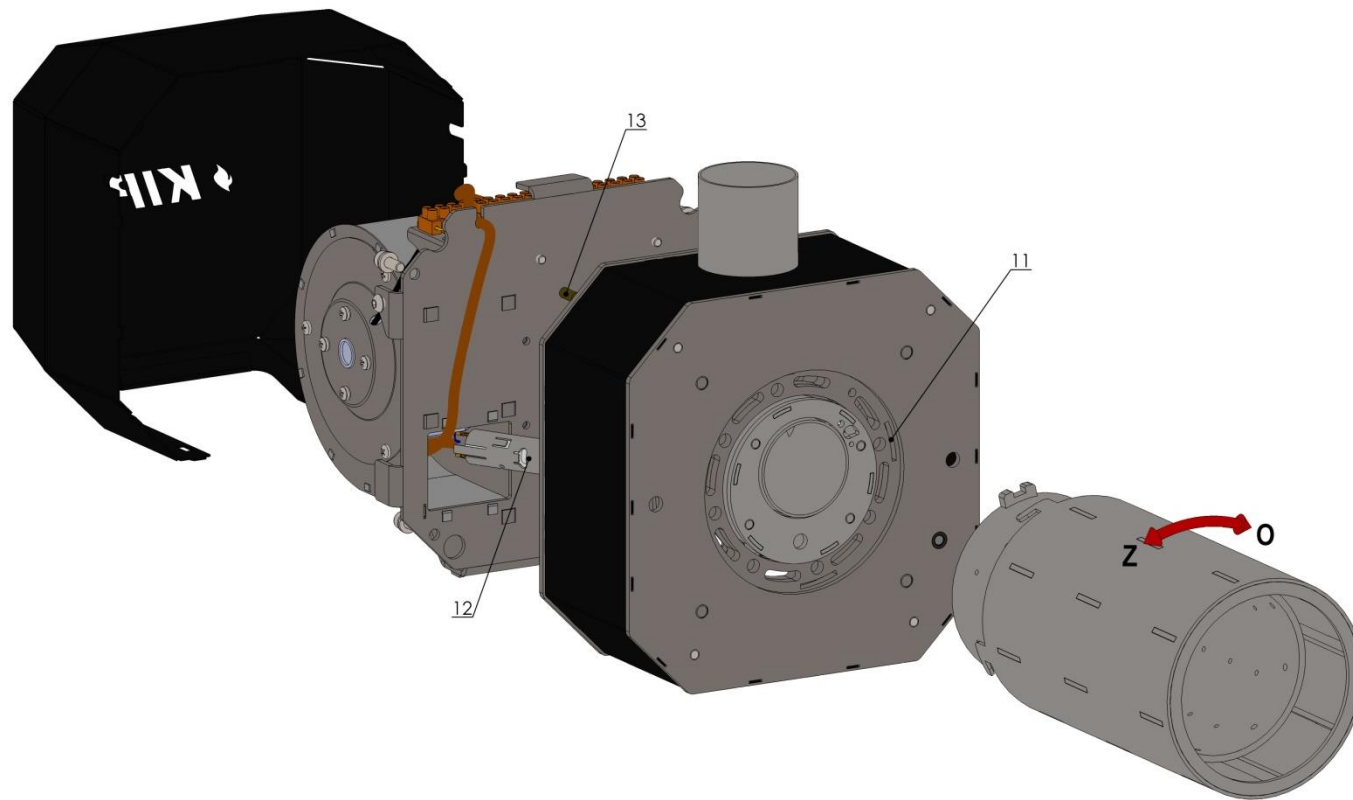

Fig. 14. Cleaning the tubular blower chamber – view 2.

9.4. Lubricating the bearings of the combustion chamber.

In order to ensure long operational life of the burner, it is recommended to lubricate the bearings of the combustion chamber. Depending on the frequency of the burner operation, this procedure is recommended to be performed every 6-12 months. To carry out this action you, follow the instructions below:

1. Disconnect from the burner the power supplying power to the external feeder and the controller cable.
2. Loosen the fixing screws (1) that secure the burner housing -2 pcs.
3. Remove the burner housing (2).
4. Unscrew the fixing screws (3) - 4 pcs.
5. Carefully remove the plate with drives and fan (4).
6. When removing the plate (4) remove also igniter (5) from its slot.
7. Put aside the removed assembly in a safe place, paying particular attention to the igniter.
8. Unscrew screws (6).
9. Remove the shielding of the blower chamber (7), including the frame (8), tee connector (9), drive shaft (14) and diaphragm rotation shaft (15), when necessary - remove the screw securing the tee connector.
10. Lubricate the bearings of the combustion chamber (10) in a few places on the circumference, applying the lubricant between the bearing raceway and the bearing cage. For lubrication use grease (e.g. Towot, LT 43).
11. Place the shaft (14) in the bore with the sleeve (15) of the burner front plate. The latch (12) should be between the teeth of the wheel (13) - as shown in the figure.
12. Place the shaft (15) in the opening of the platen with bearings, set the gearing as shown in the figure - it is the setting for closing the diaphragm - i.e. the minimum airflow.
13. Install the housing of the blower chamber (7), including the tee connector (9) and frame (8). Splines in the housing sheet should match the slots in the front panel of the burner, the tee connector should be placed in the opening of the screen. Install the frame (8) - also in this case splines should match correct slots. If necessary, tighten the screw securing the tee connector. The end of the drive shaft (14) should match the slot (14), while the diaphragm rotation shaft (15) should match opening the (16).
14. Tighten screws (6).
15. Mount the plate with drives (4), during this step placed the igniter (5) in its slot, pushing it firmly to the screen plate. The undercut (11) in the drive shaft must match the undercut in the shaft of the drive motor - you may rotate the drive shaft by turning the tube (1) in

"Z" direction. The temperature sensor should match the slot in the tee connector of the fuel supply.

16. Tighten screws (3).
17. Replace the housing (2).
18. Tighten screws 1.
19. Connect cables disconnected in par. 1.
20. The burner is ready for operation.

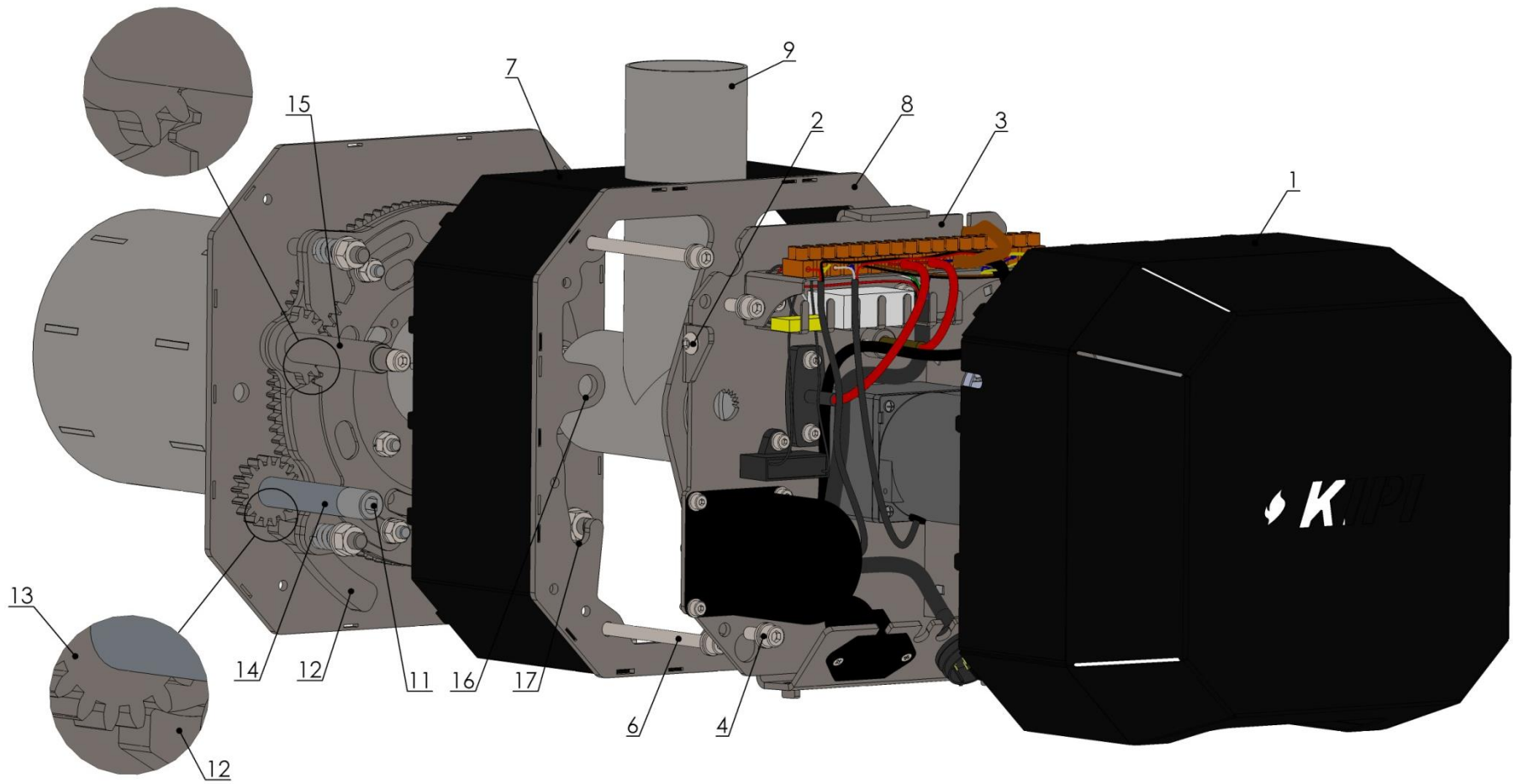

Fig. 16. Lubricating the bearings of the combustion chamber - view 1.

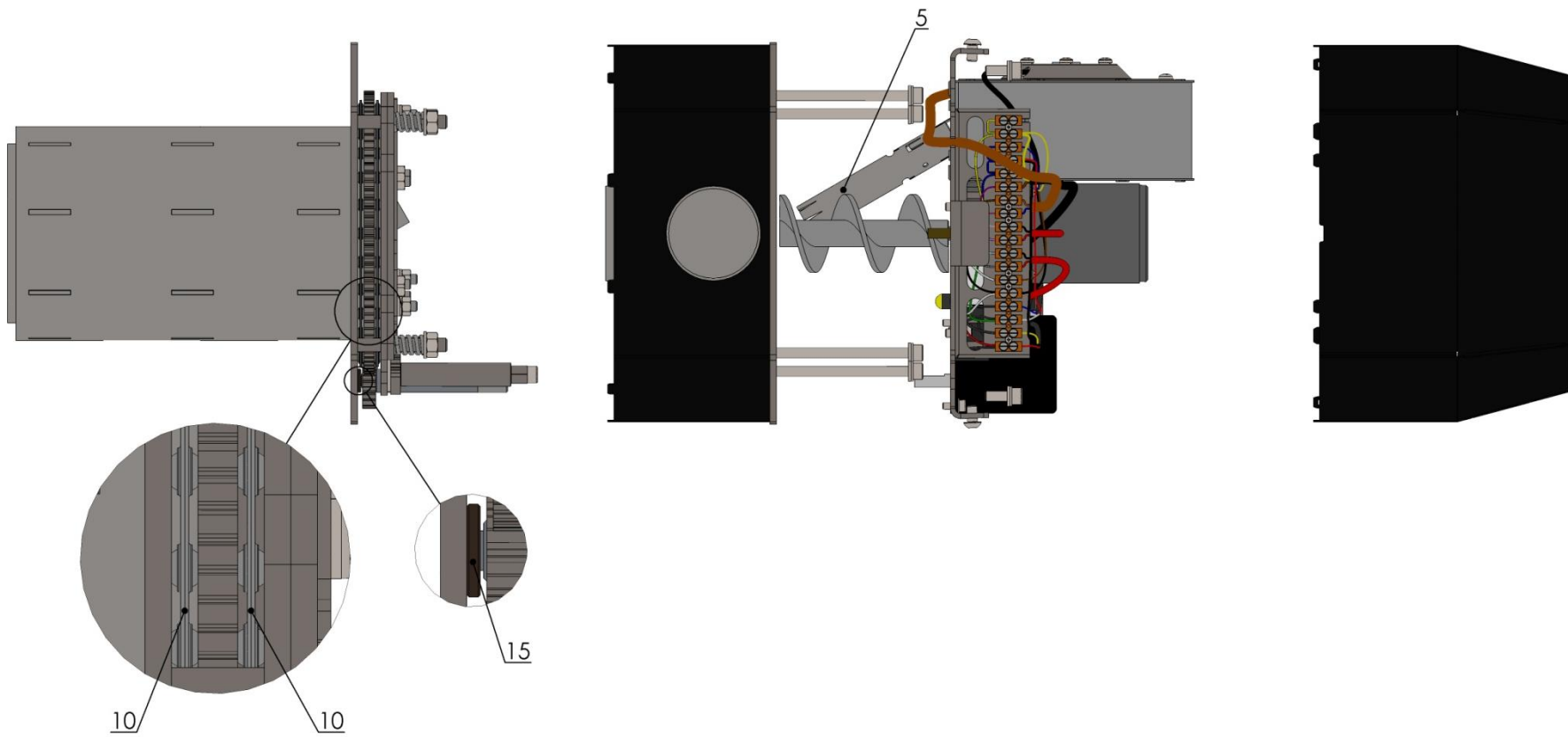

Fig. 17. Lubricating the bearings of the combustion chamber - view 2.

9.5. Igniter Replacement.

The igniter may be replaced by a service technician assigned by the manufacturer or by a person with a permit for performing electric works up to 1 kV. The replacement should be carried out in accordance with the following description and the accompanying drawing.

1. Disconnect from the burner the power supplying power to the external feeder and the controller cable.
2. Loosen the fixing screws (1) that secure the burner housing -2 pcs.
3. Remove the burner housing (2).
4. Unscrew the fixing screws (3) - 4 pcs.
5. Carefully remove the plate with drives and fan (4).
6. When removing the plate (4) remove also igniter (6) from its slot (9).
7. Remove only the igniter from the tube.
8. Depending on the type, connect cables (8) to the new igniter or connect firmly the cables of the igniter to terminals; Z2 - brown wire, Z4 - blue wire.
9. Place the igniter inside the tube in a manner enabling it to slide out of the tube, if necessary bend lamellas locking the igniter inside the tube.
10. Place the installed igniter in the slot (9), pushing it to the screen plate.
11. Place the igniter cable in the cable gland (5).
12. Mount the plate with drives (4). The temperature sensor should match the slot in the tee connector of the fuel supply. Tighten screws (7).
13. Replace the burner housing (2).
14. Tighten the fixing screws (1).
15. Connect cables disconnected in par. 1.
16. The burner is ready for operation

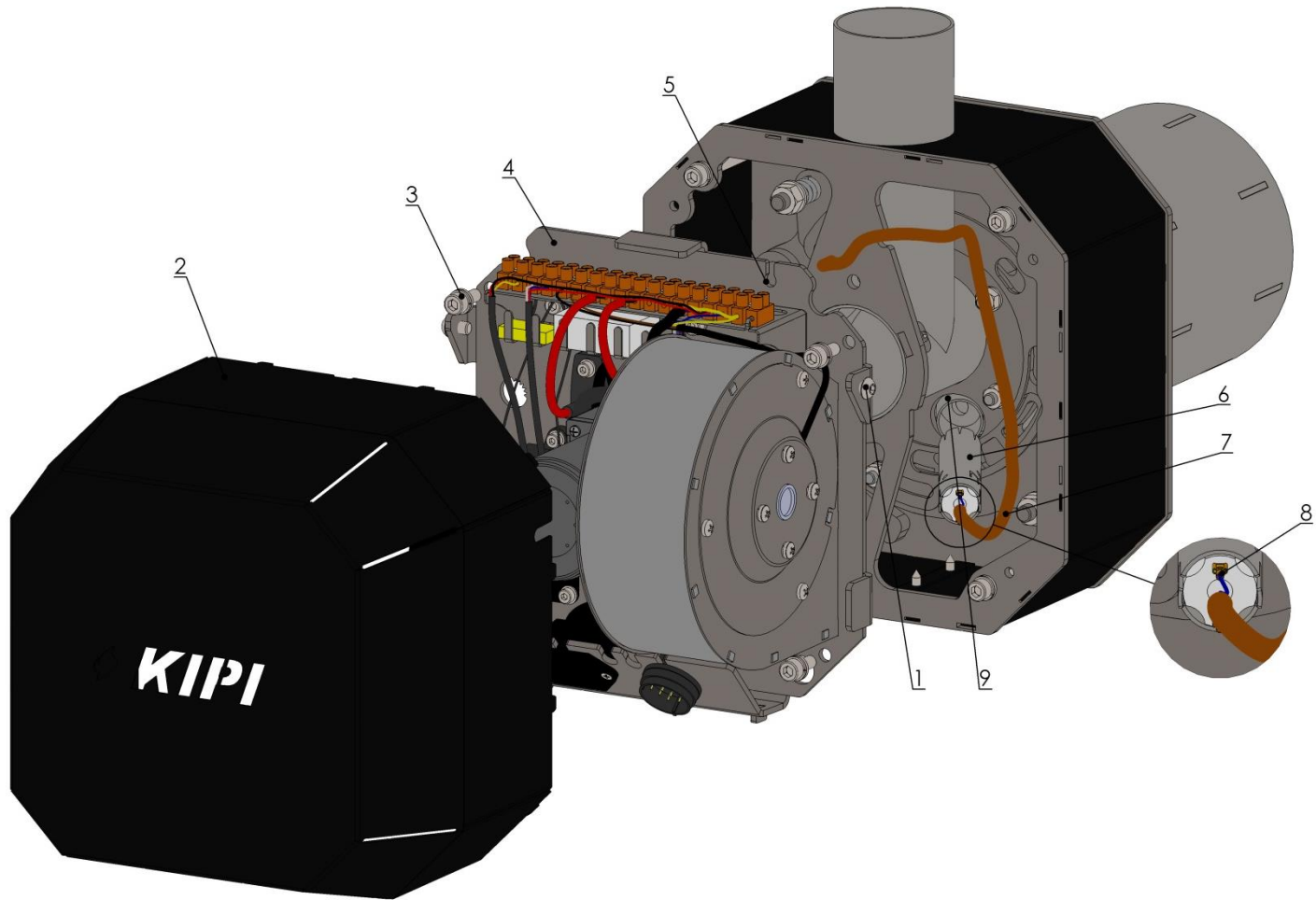

Fig. 18. Igniter Replacement.

10. Operational Safety.

In order to ensure the safety of the user of the burner, the following steps should be applied:

1. During the operation of the burner, do not open the door of the boiler with a burner mounted therein.
2. In the event of ignition of fuel inside the burner it should be immediately unplugged from the power source and only then eventually any firefighting operations can be carried out.
3. Keep the boiler room clean and do not store there any unnecessary items.
4. The burner shall be operated only by adults trained in the operation and maintenance of such devices, according to the user manual.
5. The burner, boiler, central heating and DHW should be kept in good condition.
6. Pay particular attention to the tightness of the water in the vicinity of the burner - any spills can damage the burner, as well as increase the risk of electric shock.
7. The burner and tray are equipped with rotating parts - do not insert hands, fingers or other objects into during their operation.
8. It is not allowed to interfere with the burner automation systems and other electrical devices installed in it.
9. The burner is a device generating heat - some of the elements of the burner can be heated - use caution in contact with them.
10. It is forbidden to use the burner connected by the user himself and without the acceptance signed by an authorized service technician.
11. It is not allowed to connect the burner to not adapted boiler.
12. The burner cannot function as an independent unit.
13. It is not allowed to place items on the burner.
14. It is not allowed to use other methods of ignition in particular, the use of flammable materials.
15. The burner must be used with its outer casing attached to it and with all protection systems operational.

11. Burner Liquidation after its Service Life is Over

After exceeding the service life of the igniter it should be utilized according to the requirements of environmental protection

12. Electric diagram.

12.1. Electric diagram of the controller.

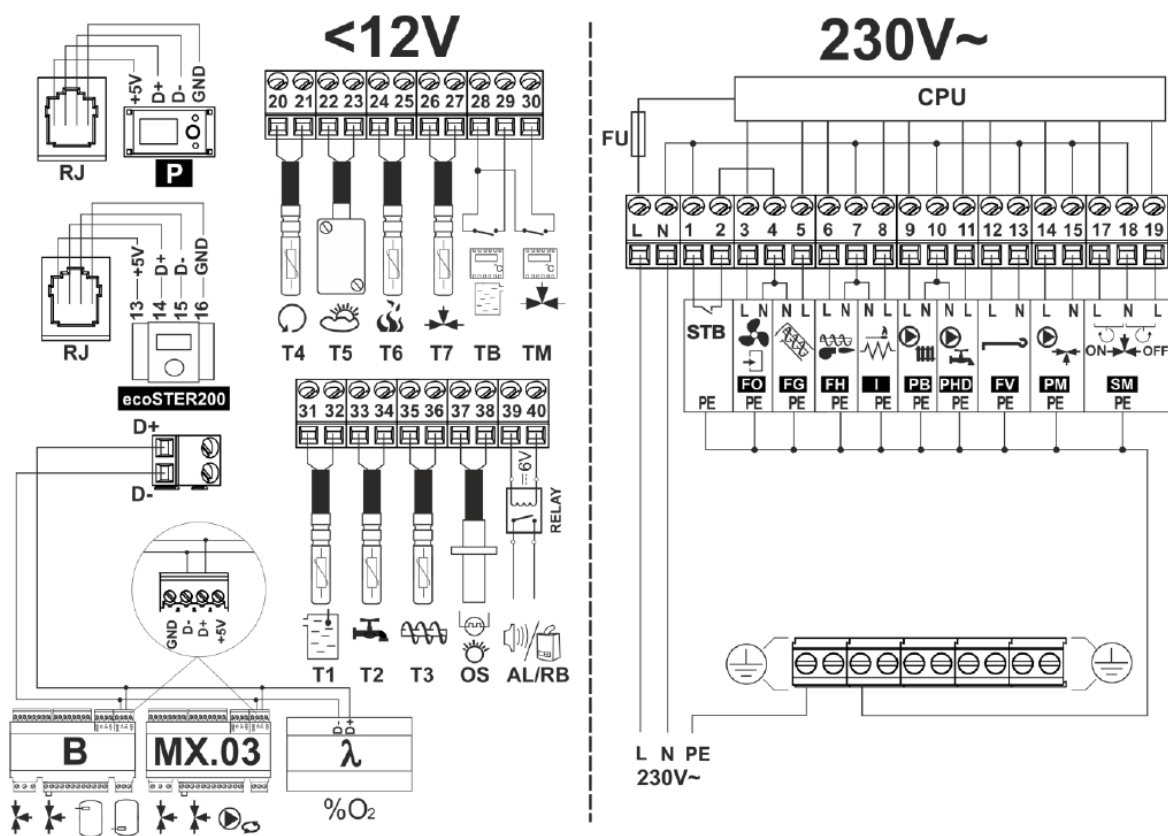

Fig. 19. Wiring diagram of the controller, where:

Connection marking	Function / sub-assembly
T1	temperature sensor of CT4 boiler
T2	DHW temperature sensor CT4
T3	feeder temperature sensor
OS	flame optical sensor
AL/RB	voltage output for alarm signalling or reserve boiler control
RELAY	relay

T5	weather temperature sensor CT4-P
T6	exhaust gas temperature sensor CT2S
T7	mixer temperature sensor
TB	room thermostat input to the boiler
TM	room thermostat input to the mixer
P	control panel, ecoSTER200 – room panel with room thermostat function (replaces TB or TM)
D-D+	connection for additional modules
B	module B adds the support of two additional mixer circuits and operation of the thermal buffer
MX.03	additional module provides the control of additional two mixers and a circulation pump
λ	Lambda probe module
L N PE	mains 230V~
FU	mains fuse
STB	safety temperature limiter input
FO	air blower for the burner
FG	main feeder
FH	burner feeder
I	igniter
PB	boiler / buffer pump
PHD	hot water pump
FV	motor for rotational cleaning of the burner
PM	mixer pump
SM	mixer servomotor
CPU	control

12.2. Electric diagram of the burner.

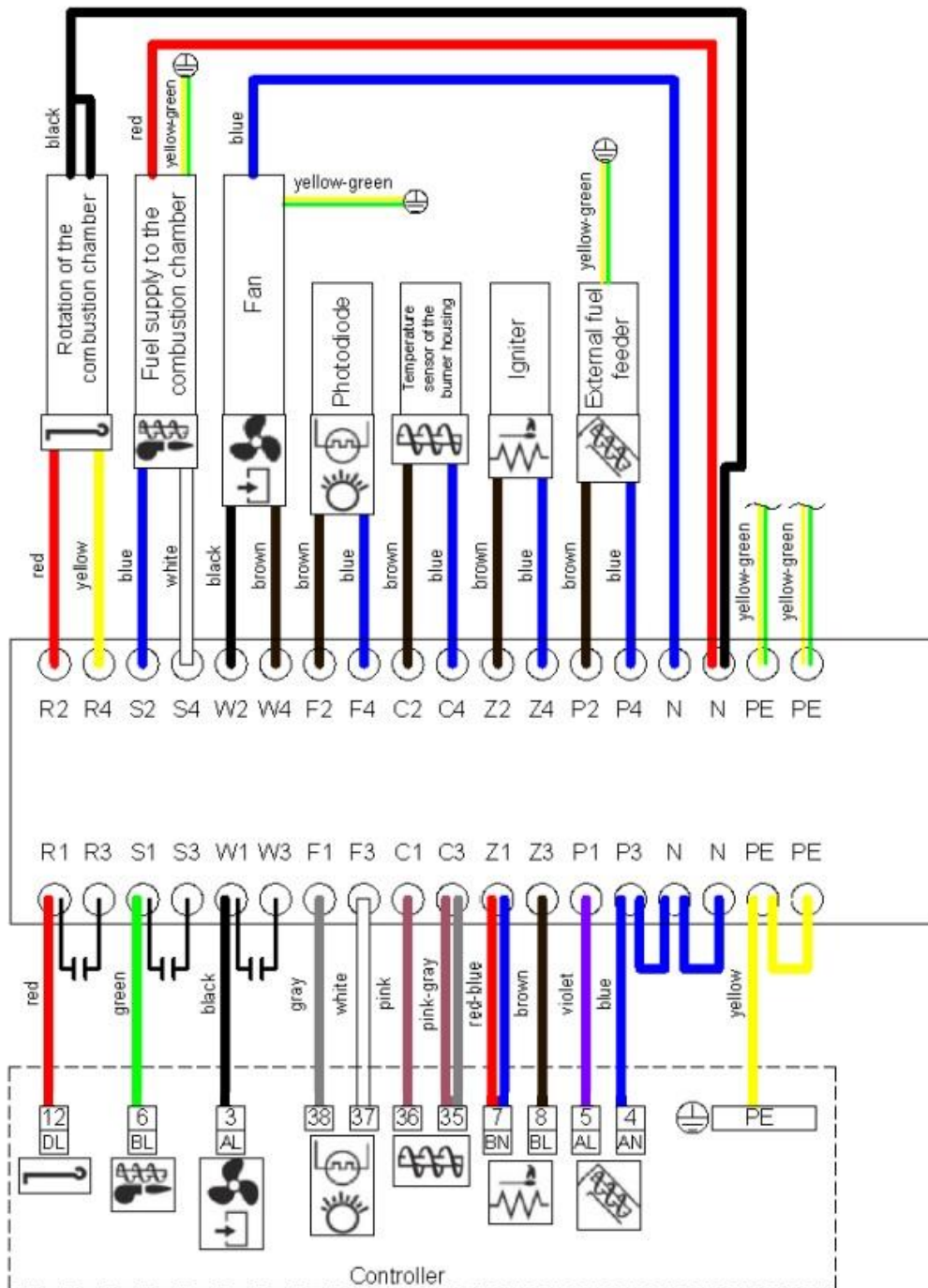

Fig. 20. Wiring diagram of the burner, where:

Terminal strip of external electrical box:

Connection marking	Function / sub-assembly
R2, R4	Rotation of the combustion chamber
S2, S4	Fuel supply to the combustion chamber
W2, W4	Fan
F2, F4	Photodiode
C2, C4	Temperature sensor of the burner housing
Z2, Z4	Igniter
P2, P4	External fuel feeder
PE	Earthing
N	Neutral conductor

Protective strip - PE:

Connect all yellow-green conductors/cables.

13. Burner models, Overall and Mounting Dimensions.

13.1. ROT-POWER 4-18 kW.

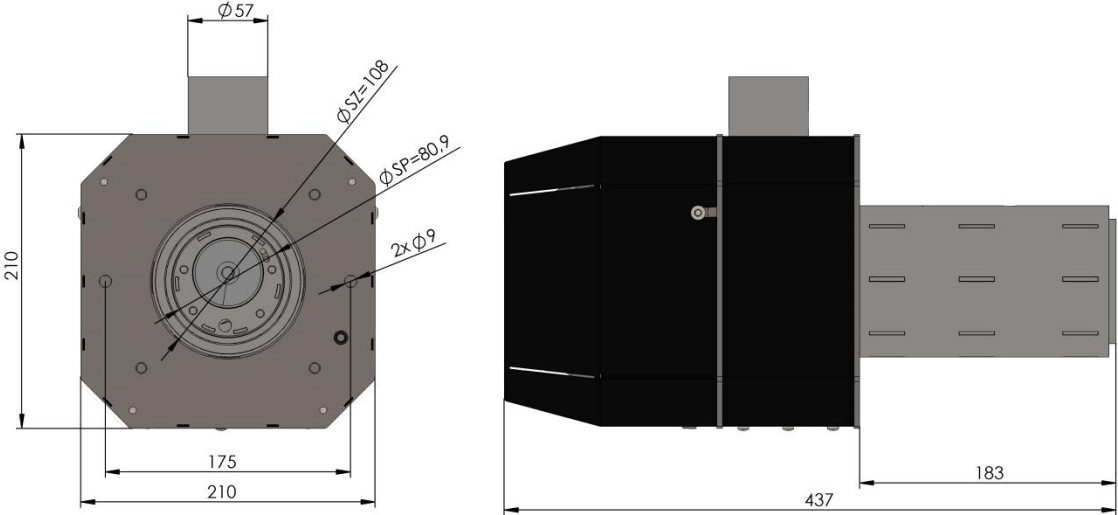

Fig. 21. View of burner 4-18 kW.

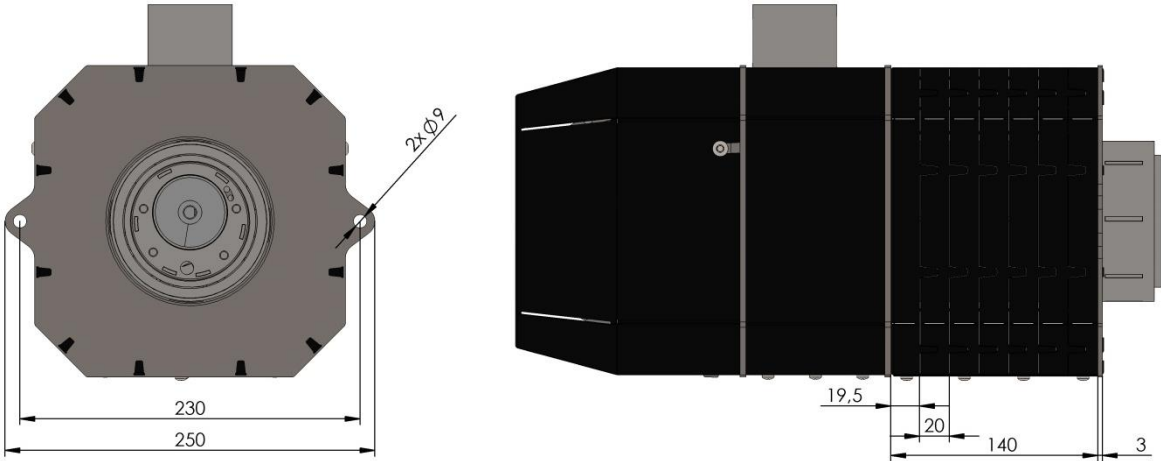

Fig. 22. View of Burner 4-18 kW , including the insulating jacket and the mounting plate.

13.2. ROT-POWER 6-26 kW.

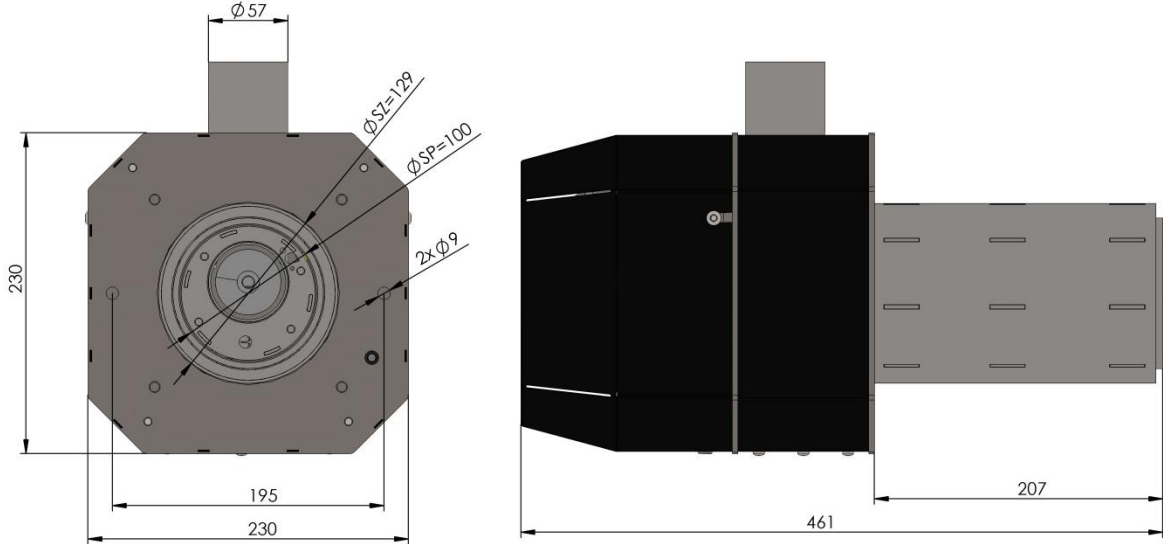

Fig. 23. . View of burner 6-26 kW.

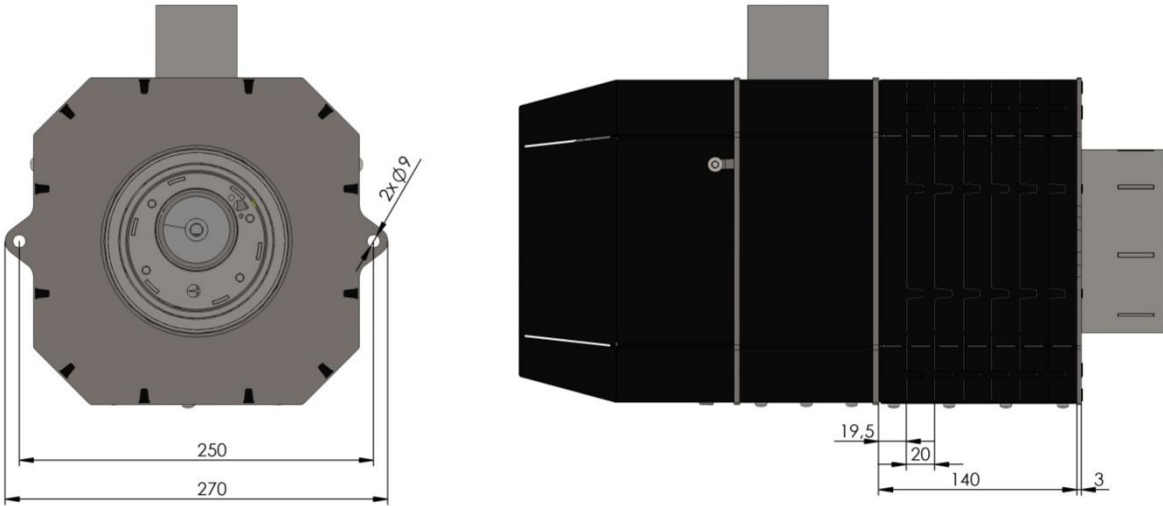

Fig. 24. . View of burner 6-26 kW, including the insulating jacket and the mounting plate.

13.3. ROT-POWER 8-36 kW.

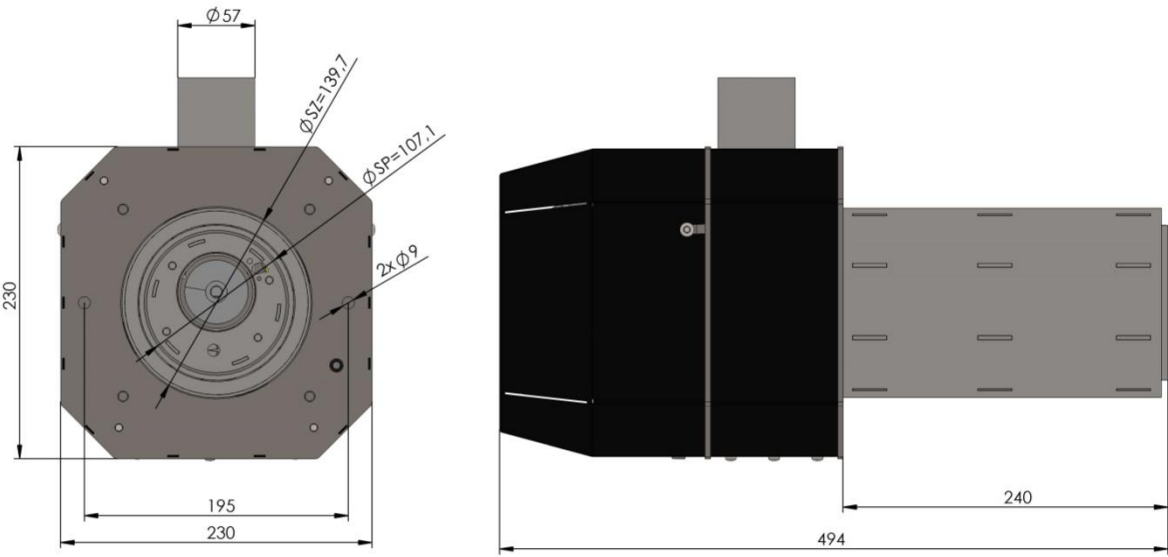

Fig. 25. View of burner 8-36 kW.

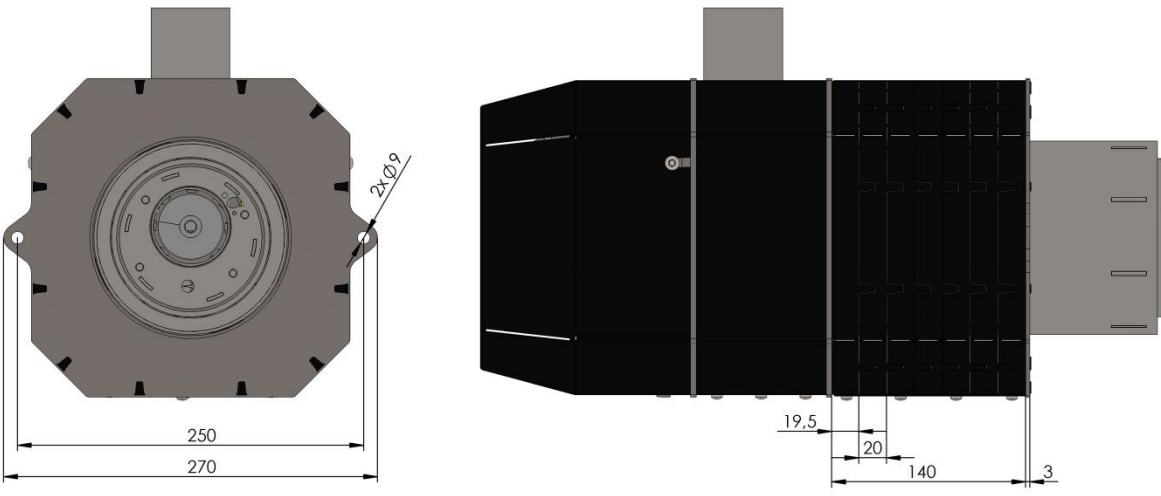

Fig. 26. View of burner 8-36 kW, including the insulating jacket and the mounting plate.

13.4. ROT-POWER 10-50kW.

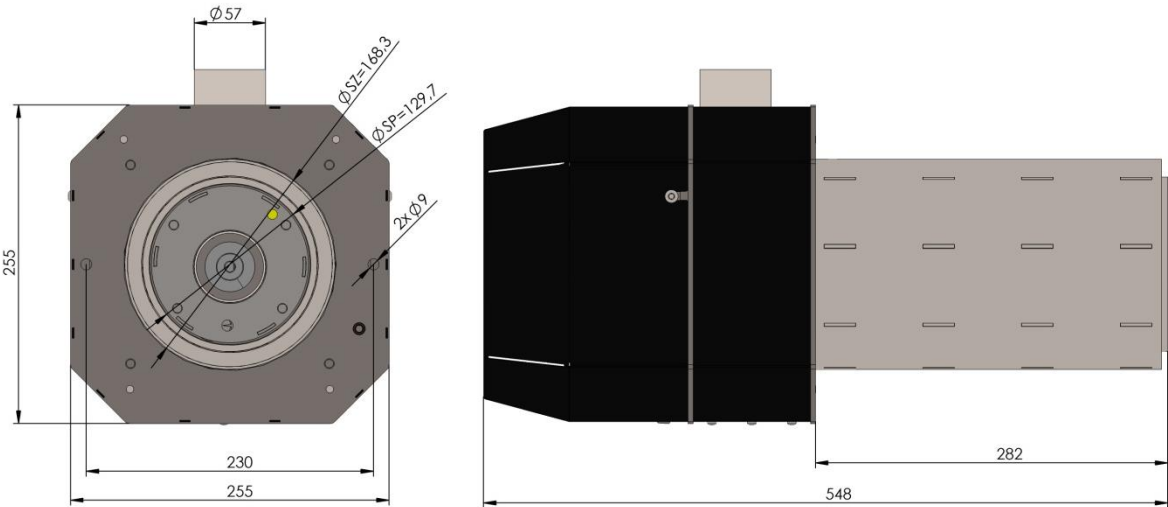

Fig. 27. View of burner 10-50 kW.

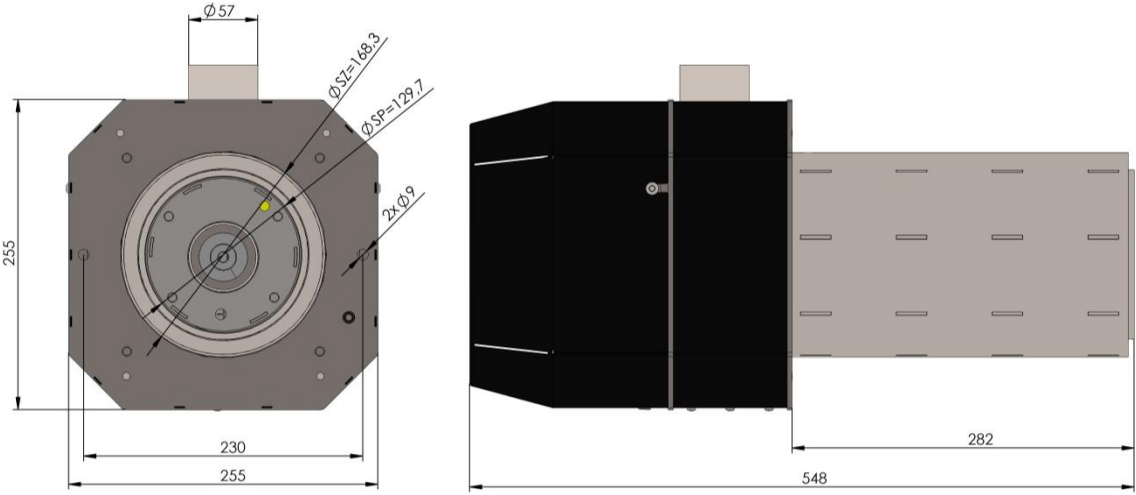

Fig. 28. View of burner 10-50 kW, including the insulating jacket and the mounting plate.

14. Manufacturer's Initial Settings - Basic Operation Parameters.

Parameter	Models			
	4-16 kW	6-26 kW	8-36 kW	10-50 kW
1. Drive of the external feeder	3GN 200	3GN 200	3GN 200	3GN 200
2. Ventilation revolutions for firing				
3. Ventilation revolutions for 100% power				
4. Ventilation revolutions for 50% power				
5. Ventilation revolutions for 30% power				
6. Starting dose of fuel				
7. Fuel dose for 100% power				
8. Fuel dose for 50% power				
9. Fuel dose for 30% power				
10. Furnace extinguish time				

15. Burner's technical data.

Parameter	Models	
	4-18 kW	6-26 kW
1. Power	4-18 kW*	6-26 kW*
2. Power supply	230 VAC, 50 Hz (6 A)	
3. Average power consumption	40 W	50 W
4. Igniter's power	200 W	
5. Combustion efficiency	> 99 %	
6. Boiler efficiency	> 96 %	
7. Power Adjustment	YES (power modulation correctly the burner)	
8. Operation of the central heating pump	YES	
9. Operation of the DHW	YES	
10. Burner control by room thermostat	YES	
11. Burner control with a weather compensator	YES (option)	
12. Pellet feeder	YES (Ø60 x 1850 mm operational)	
13. Brandling pipe	YES (Ø60 x 750 mm)	
14. Required chimney draft	10-20 Pa	

Parameter	Models	
	8-36 kW	10-50 kW
15. Power	8-36 kW*	10-50 kW*
16. Power supply	230 VAC, 50 Hz (6 A)	
17. Average power consumption	60 W	70 W
18. Igniter's power	200 W	
19. Combustion efficiency	> 99 %	
20. Boiler efficiency	> 96 %	
21. Power Adjustment	YES (power modulation correctly the burner)	
22. Operation of the central heating pump	YES	
23. Operation of the DHW	YES	
24. Burner control by room thermostat	YES	
25. Burner control with a weather compensator	YES (option)	
26. Pellet feeder	YES (Ø60 x 1850 mm operational)	
27. Brandling pipe	YES (Ø60 x 750 mm)	
28. Required chimney draft	10-20 Pa	

* - nominal power of the burners is given for the use of pellets produced in accordance with DIN or DIN Plus Specifications. For pellets with other parameters of combustion, in particular with a different calorific value, ash level and moisture - the power may be lesser.

DECLARATION OF CONFORMITY



Manufacturer:

BTI GUMKOWSKI Sp. z o.o. Sp. k.
ul. Obornicka 71, 62-002 Suchy Las

declares that:

Pellet Burner unit, type: ROT-POWER, model: 4-18 kW, 6-26 kW, 8-36 kW,
10-50 kW meets the requirements and is compatible with:

- 2006/42/WE,
- 2006/95/WE,
- 2004/108/WE,

and complies with the following harmonized standards:

- PN-EN 953+A1:2009,
- PN-EN ISO 13732-1:2009,
- PN-EN 60127-1:2008/A1:2012,
- PN-EN 60445:2011E,
- PN-EN 60519-1:2011E,
- PN-EN 60730-2-5:2006/A2:2010E,
- PN-EN 60730-1:2012E,
- PN-EN ISO 12100:2012,
- PN-EN 61000-6-3:2008,
- PN-EN 60730-2-9:2011,
- PN-EN 15270:2008.

The person authorized to compile the technical file is: Szymon Bajerlein.

Poznań, dn. 15-10-2014

A handwritten signature in blue ink, appearing to read "Jan", is positioned above the printed name.

Jan Gumkowski

BTI GUMKOWSKI Sp. z o.o. Sp. k.
ul. Obornicka 71, 62-002 Suchy Las
KRS 0000520520 NIP 9721251263
REGON 302832793 tel. 61 811 70 37

16. Burner Installation Protocol.

Customer's Data	
Name:	
Address:	
Phone:	
E-mail:	

Seller's Data	
Company Name:	
Address:	
Phone:	

Fitter's Data	
Company Name:	
Address:	
Phone:	

Installation Data	
Burner type/model:	
Serial Number:	
Power:	
Year of production:	
Installation Date:	
Boiler:	
Year of production:	
Boiler power:	

Data on the burner settings at the time of installation	
Ventilation revolutions for 100% power	
Ventilation revolutions for 50% power	
Ventilation revolutions for 30% power	
Amount of fuel for 100% power	
Amount of fuel for 50% power	
Amount of fuel for 30% power	
Hearth brightness for the flame failure	

Hearth brightness for ignition	
Hearth brightness till the igniter turn off	
A number of hearth ignitions	
The results of the gas analysis	
Exhaust temp. MIN power	
Exhaust temp. MAX power	
CO ₂ emissions at MIN power	
CO ₂ emissions at MAX power	
Chimney Draft	
Excess air ratio λ	
Efficiency	

I have read this Service Manual, understand its content, I accept the conditions of the warranty. I have been trained to operate the burner.

Date:	Customer's signature:
----------------	--------------------------------

26. Warranty.

1. The manufacturer, BTI GUMKOWSKI Sp. z o.o. Sp. k., provides a 36-month guarantee for the smooth operation of the ROT-POWER Burner to the extent described in this Service Manual, starting from the date of the Burner installation (with the exception of point 2), provided that the annual payable inspection of the burner is carried out by an authorized installer of the burner. Otherwise, the guarantee is valid for 12 months.
2. The igniter warranty lasts for a period of 2 years or 800 ignitions.
3. Defects found during the warranty period shall be removed within 21 working days from the date of filing the complaint.
4. Any defect disclosed during operation must be reported promptly.
5. Documents required to perform free repairs are: completed Installation Protocol and proof of purchase of the burner.
6. Warranty Card is not valid in the case of absence of the required stamps, signatures and dates.
7. Completed installation protocol should be sent to the manufacturer within 14 days from the date of installation of the burner in paper or electronic form.
8. The first run of the burner and setting the operating parameters is the one carried out by an authorized service technician.
9. Warranty will not apply in the case of:
 - installation, operation or use of the burner conducted not in accordance with this Service Manual,
 - any changes or burner modifications,
 - starting the burner without its installation in the boiler,
 - too small cross section of the chimney or too narrow chimney draft,
 - repairs by persons not authorized by the Manufacturer,
 - malfunction of the electrical system,
 - incorrect parameter setting of the burner,
 - combustions of fuels not included in the Manufacturer's specifications,
 - the impossibility to access the installed burner.
10. Warranty does not cover:
 - adjustment of the burner parameters,
 - cleaning and maintenance.
11. Costs of service calls for repairs related to paragraphs 9 and 10 shall be covered by the customer.
12. Complaints should be reported: by mail, electronically or by fax.

Warranty Card

Nr...../.....

Burner type/model:

Serial Number:

Year of production:

Date of sale:

Comments:

.....

.....
manufacturer's signature and stamp

(Fills the point of sale)

Maturity guarantee (subject to perform annual inspections by Warranty Terms and Conditions p.1):.....

.....
date, the point of sale's signature and stamp

(Service fills)

Protocol burner maintenance and repair

Date maintenance / repair	Specification	the point of sale's signature and stamp