

THE

# CLIMAX C2

OWNER and SERVICE MANUAL Rev 4



**AirBorne**  
AUSTRALIA

PO Box 7042, REDHEAD, NSW 2290 AUSTRALIA

E-mail [fly@airborne.com.au](mailto:fly@airborne.com.au)

[www.airborne.com.au](http://www.airborne.com.au)

Phone (02) 4944 9199 Int +61 2 4944 9199

Fax (02) 4944 9395 Int +61 2 4944 9395

**MANUAL REVISION HISTORY**

<b>Revision No</b>	<b>Description</b>	<b>Applicable Serial No</b>	<b>Date</b>
0	Original	CL13-1 CL14-1	1 <sup>st</sup> February 2001
1	Inclusion of drawings	CL13-1 CL14-1	1 <sup>st</sup> October 2001
2	Tip lever standard positions changed. Inclusion of performance tuning information	CL13-97 CL14-53	1 <sup>st</sup> March 2002
3	Climax C2	C2-13: 150 C2-14: 100	1 <sup>st</sup> September 2002
4	Pull back 2:1 Batten Clips Sprog templet	C2-13: 163 C2-14: 120	1 <sup>st</sup> February 2003



## TABLE OF CONTENTS

<b>TABLE OF CONTENTS</b>	<b>4</b>
<b>Section 1 DESIGN FEATURES</b>	<b>6</b>
<b>Section 2 SPECIFICATIONS</b>	<b>7</b>
<b>Section 3 OPERATING LIMITATIONS</b>	<b>8</b>
<b>Section 4 WARRANTY STATEMENTS</b>	<b>9</b>
<b>Section 5 ASSEMBLY PROCEDURES</b>	<b>10</b>
ASSEMBLING ON THE FRAME	10
ASSEMBLING LYING FLAT	13
<b>Section 6 PRE-FLIGHT INSPECTION</b>	<b>15</b>
HANG GLIDER DAILY INSPECTION	16
<b>Section 7 BREAK DOWN PROCEDURE</b>	<b>17</b>
<b>Section 8 SHORT PACKING</b>	<b>19</b>
ASSEMBLE FROM SHIPPING LENGTH	19
BREAKDOWN FOR SHIPPING	20
<b>Section 10 SAIL REMOVAL AND RE-INSTALLATION</b>	<b>21</b>
REMOVING THE SAIL	21
RE-INSTALLING THE SAIL	22
<b>Section 11 FLIGHT TECHNIQUE</b>	<b>23</b>
TAKE OFF ..DON'T FORGET TO HOOK IN...	23
TURNS	23
STALLS	23
SPINS	23
THERMALLING	24
LANDING	24
<b>Section 12 TUNING</b>	<b>25</b>
PITCH TRIM	25
PITCH STABILITY SYSTEM	25
CHECKING THE CLIMAX STABILITY SYSTEM	26
PREPARING THE TEMPLATE	26
CHECKING THE SPRONG ANGLES	26
ROLL/YAW TRIM	27
ROLL TRIM ADJUSTMENTS	28
TIP LEVER ADJUSTMENT	29
SPROG ADJUSTMENT FOR SYMMETRY	29
HANDLING AND PERFORMANCE TUNING	30

<b>Section 13 PERIODIC INSPECTIONS and MAINTENANCE</b>	<b>31</b>
MAINTENANCE SCHEDULE	31
LOG BOOK	31
NOTES ON PERIODIC INSPECTIONS	32
AIRFRAME TUBING	32
CARBON CROSS TUBES	32
BOLTS	32
INSPECTION AFTER HARD LANDING	33
DEFECT REPORTS	33
<b>Section 14 TRANSPORTATION AND STORAGE</b>	<b>34</b>
<b>Section 15 MAINTENANCE RECORD</b>	<b>35</b>
<b>Section 16 HANG GLIDER COMPLIANCE SCHEDULES</b>	<b>36</b>
GLIDER MODEL: CLIMAX 13	36
GLIDER MODEL: CLIMAX 14	37
<b>Section 17 SPROG ANGLE TEMPLATES</b>	<b>38</b>
GLIDER MODEL: CLIMAX 13	38
GLIDER MODEL: CLIMAX 14	37
<b>Section 18 ASSEMBLY DRAWINGS</b>	<b>40</b>
CLIMAX II CENTER SECTION ASSEMBLY A4-5241	41
CLIMAX VG ASSEMBLY A4-5242	43
CLIMAX X-BAR LEADING EDGE ASSEMBLY A4-4824	45
CLIMAX CAM JUNCTION ASSEMBLY A4-4981	47
NOSE JUNCTION ASSEMBLY A4-4828	49
CLIMAX REAR KEEL ASSEMBLY A4-4829	51
HG A-FRAME FAIRED CORNER UNIT ASSEMBLY TPYE AB A4-7237	53
STREAMLINE CONTROL FFRAME A4-4983	55
MICRO-DRAG CONTROL FRAME A4-5317	57
CLIMAX REAR LEADING EDGE ASSEMBLY A4-4825	59
DIVE STRUT ASSEMBLY A4-4978	61

## Section 1 DESIGN FEATURES

Designed and manufactured by **AirBorne Windsports**, the Climax is one of the most advanced high performance topless hang glider on the market. The Climax C2 is the result of further refinements to the design.

Attention to detail and weight saving has allowed the Climax to have excellent static balance. A larger than average VG range provides the Climax with ease of handling and a large flare window without compromising outstanding glide performance throughout the speed range.

The Climax has an elliptical tip, which in the VG full setting allows a very tight mainsail whilst maintaining a progressive washout line right through to the tip.

AirBorne's original cam VG system has been improved allowing an increase in VG travel. Not only does the wing pull exceptionally flat when full on, the VG off setting is quite loose resulting in extremely light handling and improved climb ability. There are several advantages using the cam VG system. The drag in the pulley actuating system and lack of movement in the high load junctions allow for much lower operating pressures. The cam VG system also maintains constant anhedral, which significantly reduces glider oscillation throughout the VG range.

A combination of internal cloth ribs and Velcro tabs between the upper and lower battens control the under surface blow down at lower angles of attack. Not only does this minimise glider oscillation the resulting pitch pressure is progressive and predictable.

Wire braced washout tubes, or sprogs are used in the Climax. The centre sprog has a compensating system, which causes the sprog to raise approximately 120 mm when the VG is released. Certification pitch testing has confirmed the stability of the system with excellent pitching moment results throughout the VG range.

The Climax is easy to assemble or break down. It may be set up on the A-Frame or laid flat, thereby accommodating for personal preference or site characteristics and restrictions. Pip pins and quick clips are used with integrated spring battens to speed up assembly. The sprog tubes are secured by simply closing the zips. Easy operating internal tip levers are used to load the tip rods.

At AirBorne we have a well-developed quality assurance program, ensuring that every glider is built in accordance with the standard it was designed and tested to. This gives even the most experienced pilot a sense of security.

We hope that you have hours of great flying with your new glider. Fly high and safely.

Rick, Russell and Shane Duncan, Rob Hibberd and Paul Mollison  
**AirBorne WindSports**

## Section 2 SPECIFICATIONS

	CLIMAX 13 & C2-13		CLIMAX 14 & C2-14	
	METRIC	IMPERIAL	METRIC	IMPERIAL
SAIL AREA	13.1 sq meter	141 sq ft	14.3 sq meter	154 sq ft
WING SPAN	9.6 m	31.5 feet	10.4 m	34.0 feet
ASPECT RATIO	7.0		7.5	
NOSE ANGLE	128-133 degrees		128-133 degrees	
DOUBLE SURFACE %	92%		92%	
BATTENS	22 + 6		24 + 6	
GLIDER WEIGHT	33 kg	73 pound	36 kg	79 pound
ASSEMBLY TIME	10 min		10 min	
PACK UP LENGTH	4.9 meter	16' (feet)	5.3 meter	17'-3" (feet)
SHORT PACK LENGTH	3.8 meter	12'-6" (feet)	4.1 meter	13'-6" (feet)
RECOMMENDED PILOT HOOK IN WEIGHT RANGE (Includes Equipment)	55-90 kg	121-198 pounds	75-120 kg	165-264 pounds
VNE (Recommended Maximum Velocity)	85 km/h	53 mph	85 km/h	53 mph
VA (Recommended Maximum Rough Air Manoeuvring Velocity)	74 km/h	46 mph	74 km/h	46 mph
VD (Maximum Steady State Velocity)	115+ km/h	70+ mph	115+ km/h	70+ mph

**Note:** The stall speed of the Climax at maximum recommended wing loading is less than the minimum requirement of 25 mph (40 km/h). The minimum or steady state speed is at least 35 mph (56 km/h) for a prone pilot with correctly adjusted harness.

Conversions: \* 0.4536 kg/pound \* 25.4 mm/inch \* 1.609 km/mile  
 $V_a = \text{Test speed} \times 0.707$   
 $V_{ne} = \text{Test Speed} \times 0.816$

## Section 3 OPERATING LIMITATIONS

### WARNING

Hang Gliding is a high-risk sport. The safe operation of this hang glider ultimately rests with you, the pilot. We believe that in order to fly safely you must maturely practice the sport of hang gliding. You should never fly this hang glider beyond the placard limits. The velocity never to exceed (VNE) for your glider is given in Section 2, as is the maximum speed for manoeuvres or flying in rough air (VA). The indicated airspeeds given are for calibrated instruments mounted on, or near, the base bar of the control frame. It is recommended that you fly your Climax with an airspeed indicator, as it is relatively easy in the VG on configuration to exceed the placard limitations. Flight operations should be limited to non-aerobatic manoeuvres where the pitch angle does not exceed 30 degrees up or down to the horizon and where the bank angle does not exceed 60 degrees. Aggressive stalls and spins should not be attempted. Operations outside the recommended flight envelope, such as aerobatic manoeuvres or erratic pilot technique may ultimately produce equipment failure. Your glider was designed for foot launched soaring and should not be flown by more than one person at a time. It should not be flown backwards or inverted. The setting up and breaking down of a hang glider, transportation on cars and flying itself will have an effect over time on its structural integrity. The glider will require maintenance as outlined in the maintenance section of this manual. Like any aircraft safety depends on a combination of careful maintenance and your ability to fly intelligently and conservatively. The owner and operator must understand that due to inherent risks involved in flying a hang glider, no warranty of any kind is made or implied against accidents, bodily injury and death, other than those that cannot by law be excluded. We hope that your new glider will provide you with many hours of safe flying.

### AIRBORNE.



## Section 4 WARRANTY STATEMENTS

This warranty extends to new **Hang Gliders** and/or accessories and equipment manufactured by **AIRBORNE WINDSPORTS PTY LTD** ("Airborne") and shall not embrace any other accessories or equipment in the sale.

**AIRBORNE** warrants to the customer the hang glider and/or accessories manufactured or supplied by **AIRBORNE** to be free from defect in material and workmanship under normal use and service and of merchantable quality and fit the purpose for which they are ordinarily used. This Warranty will apply for a period of ninety (90) days from the date of dispatch of the hang glider notwithstanding the number of hours flown but subject to the hang glider remaining the property of the customer. This warranty does not exclude any rights implied in favour of any customer by any applicable Federal and State legislation.

**AIRBORNE** will make good any parts required because of defective material or workmanship as set out in the Warranty.

### **THE WARRANTY WILL NOT APPLY TO:**

Any mechanical adjustments, parts, replacements, repairs or other servicing that in the judgement of **AIRBORNE** are made or should be made as maintenance.

Any defect caused by any alteration or modification not approved by **AIRBORNE**.

Any defect caused by the fitment of parts that are not made or approved by **AIRBORNE**.

Any defect caused by misuse, accidents, negligence or failure to carry out proper maintenance service.

Damage caused by continued operation of the hang glider after it is known to be defective.

Any defect or consequential loss, damage or injury caused by overloading.

Loss of use of the hang glider, loss of time, inconvenience, damages for personal injuries, loss of property or other consequential damages.

Failure due to wear and tear, accident, fire, incorrect or incomplete rigging and/or assembly, exposure to the elements, operation outside the placarded limitations and repairs attempted or made other than by **AIRBORNE** or its authorised agent.

**AIRBORNE** will replace, free of charge, any original part that is determined by it to be defective under the terms of this Warranty and reserves the right to pay monetary compensation or make good the defect in any manner it deems appropriate.

The customer is responsible for transporting the hang glider or parts to and from **AIRBORNE** or its authorised agent when making claims under this Warranty. The hang glider or parts are at the customer's risk whilst in transit to and from **AIRBORNE** or its authorised agent.

**NOTE:** Warranty service is available to the customer from **AIRBORNE WINDSPORTS PTY LIMITED** or authorised agent.

## Section 5 ASSEMBLY PROCEDURES

The wing can be assembled in two positions, either lying flat or standing on the control frame. Assembling the Climax on the control frame is the most popular method of assembly in light winds. This method is preferable as the sail is less prone to being soiled or damaged during assembly. In higher winds it is preferable to lay the glider flat for assembly with the nose into the wind until ready to launch.

### **ASSEMBLING ON THE FRAME**

**UNZIP THE BAG.** Lay the wing down with zip up and the nose facing approximately 120 degrees from the wind direction.

**ASSEMBLE CONTROL FRAME.** Spread the control bar down tubes and insert the base bar. The pip pin is then inserted with the cover firmly secured. Check that all the rigging wires are outside the control frame.

**STAND GLIDER UP.** Rotate the control frame to the vertical position and rotate the wing 180 degrees so that it is sitting on the base bar.

**REMOVE BAG.** Remove the glider bag and unclip all of the ties. The Sprog tube covers should also be removed at this time.

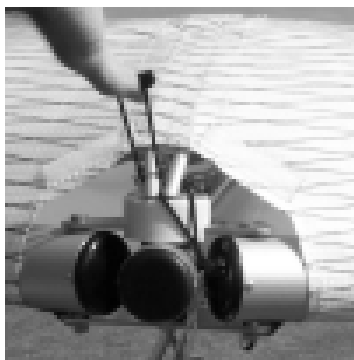

**INSERT NOSE BATTEN.** Load the nose battens on the locating pins at this time. If you fail to load the battens prior to tensioning the glider the VG should be pulled full tight before attempting to load the battens.

**SPREAD LEADING EDGES.** Carefully spread both leading edges out half way firstly then spread leading edges to their approximate flying position. Check the side wires are not twisted.

**IT IS ESSENTIAL THAT THE KEEL AND THE LEADING EDGES ARE KEPT IN THE SAME PLANE OR DAMAGE WILL RESULT.**

**ATTACH FRONT FLYING WIRES.** Ensure that the front flying wires are secure and that the quick clip is positively locked.

**INSERT MAINSAIL BATTENS #1 - 4.** Remove the battens from the bag. The red battens are for the left side and the green for the right. Insert the battens from the centre to the tip with gentle pressure, until the batten meets resistance. Shake the sail at the trailing edge whilst maintaining gentle pressure on the batten to allow the batten to be inserted over the cross bar.

**DO NOT FORCE THE BATTENS!** The spring battens should be located securely in the trailing edge fold.



**TENSION CROSS BARS.**

The cross bars are now tensioned by pulling the 2:1 pull back rope until the shackle is positioned on the Quick Clip. Ensure that the catch is positively locked.

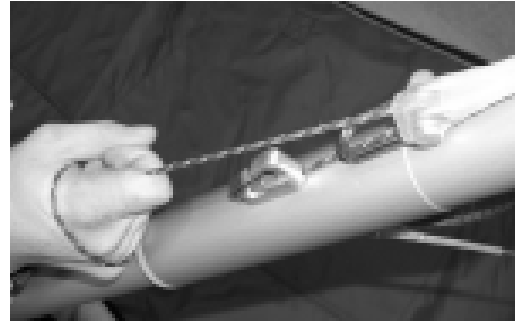
**INSERT TIP RODS.**

Remove the tip bags and insert the tip rod into the tip plug fitting at the rear of the leading edge. Ensure that the rod is fully inserted.

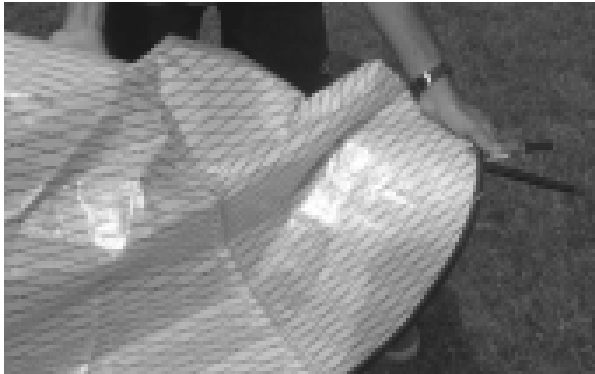
**LOAD TIP ROD.**

Move to the front of the wing. For the right tip hold the rear leading edge with your right hand and the end of the sail with your left. Align the lever plug and bend the tip tube towards the trailing edge as you tension the sail. Locate the plug on the end of the tube. When installing the left tip rod the leading edge should be held with your left hand.

**CLOSE TIP LEVER.**

Move to the tip. Place your left thumb in the rope loop of the tip lever and close the lever. The lever should be held in the same plane as the trailing edge. Do not let the lever close rapidly as damage may result. Check that the lever is against the fibre tube and is not being forced above or below the tube. Close the zip once the lever is properly closed.

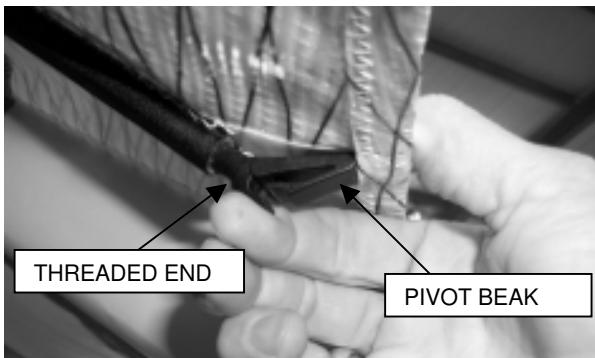
**INSERT REMAINING MAINSAIL BATTENS.**

Slide batten into sail pocket. Unclip 'pivot beak' from 'threaded end'. Rotate *pivot beak* and locate in sail as shown. While supporting the underside of the batten, clip the *pivot beak* into *threaded end*.

To adjust batten load tension, release *pivot beak* from sail and rotate batten clip. Ensure battens have an even tension distribution.

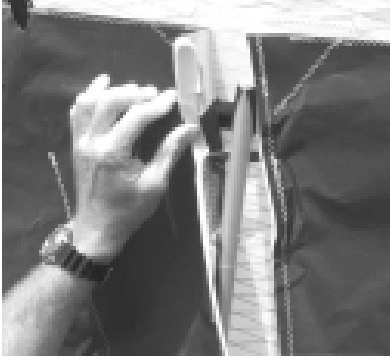
**LOAD SPROGS.**

The sprogs should be rotated into position over the red webbing loops and the zips closed fully. It is a good time to inspect the junctions prior to closing all zips.

**INSERT UNDER SURFACE BATTENS.**

The under surface battens should be inserted as far as possible. The batten should then be pushed in with your thumb. Use the string to pull the batten to the rear of the pocket.

**INSTALL NOSE FAIRING.**

Attach the nose fairing applying the top velcro first then gently tension over the nose plates and attach the velcro to the under surface.

**PRE-FLIGHT INSPECTION.**

You are now ready for the wing pre-flight inspection as outlined in the next section. It is imperative that you carry out this inspection every time you rig and before you fly.

**ASSEMBLING LYING FLAT**

UNZIP THE BAG. Lay the wing down with zip up and the nose facing into the wind. Unzip the bag and unclip centre ties

ASSEMBLE CONTROL FRAME. Spread the control bar down tubes and insert the base bar. The pip pin is then inserted with the cover firmly secured. Check that all the rigging wires are outside the control frame.

ROTATE GLIDER. Rotate the glider so that the control frame is under the wing. Make sure the rigging is not tangled.

REMOVE BAG. Remove the glider bag and unclip all of the ties. The Sprog tube covers should also be removed at this time.

INSERT NOSE BATTEN. Load the nose battens on to the locating pins at this time. Failure to do so will make it difficult to locate the battens after the sail is tensioned.

SPREAD LEADING EDGES. Carefully spread both leading edges out half way firstly then spread leading edges to their approximate flying position. Check the side wires are not twisted.

**IT IS ESSENTIAL THAT THE KEEL AND THE LEADING EDGES ARE KEPT IN THE SAME PLANE OR DAMAGE WILL RESULT.**

INSERT TIP RODS. Remove the tip bags and insert the tip rod into the fitting at the rear of the leading edge. Ensure that the rod is inserted all of the way.

LOAD TIP ROD. Move to the front of the wing. For the left tip hold the rear leading edge with your left hand and the end of the sail with your right. Bend the tip tube towards the trailing edge as you tension the sail. Locate the tip lever on to the tip rod. When installing the right tip rod the leading edge should be held with your right hand.

CLOSE TIP LEVER. Move to the trailing edge. Place your right thumb in the rope loop of the tip lever and close the lever. The lever should be held in the same plane as the trailing edge. Do not let the lever close rapidly as damage may result.

INSERT MAINSAIL BATTENS. Remove the battens from the bag. The red battens are for the left side and the green for the right. Insert the battens from the centre to the tip with gentle pressure, until the batten meets resistance. Shake the sail at the trailing edge whilst maintaining gentle pressure on the batten to allow the batten to be inserted over the cross bar. **DO NOT FORCE THE BATTENS!** The spring battens should be located securely in the trailing edge fold. The tip batten should have the bungee doubled for additional tension.

**TENSION CROSS BARS.** The cross bars are now tensioned by pulling the webbing loop until the shackle is positioned on the Quick Clip. Ensure that the catch is positively locked. When tensioning with the glider lying flat the keel can be raised approximately 200 mm to allow the side flying wires to be loose.

**ATTACH FRONT FLYING WIRES.** Lift glider and attach front flying wires. Ensure that the front flying wires are secure and that the quick clip is positively locked.

**INSTALL NOSE FAIRING.** Attach the nose fairing applying the top velcro first then gently tension over the nose plates and attach the velcro to the under surface.

**LOAD SPROGS.** The sprogs should be rotated into position over the red webbing loops and the zips closed fully. It is a good time to inspect the junctions prior to closing all zips.

**INSERT UNDER SURFACE BATTENS.** The under surface battens are inserted then pulled back into the rear of the batten pocket with the string handle.

**PRE-FLIGHT INSPECTION.** You are now ready for the wing pre-flight inspection as outlined in the next section. It is imperative that you carry out this inspection every time you rig and before you fly.

**Section 6 PRE-FLIGHT INSPECTION**

The wing was designed so that drag would be kept to a minimum. This means that most of the pre flight check points are enclosed.

A thorough pre-flight inspection is mandatory for any aircraft, and the best technique is a circular walk around the wing.

The nose area is the ideal place to start your pre-flight check, followed by each assembly point.

Keep in mind the three most critical set up areas:

THE NOSE QUICK CLIP  
CONTROL BAR BASE TUBE FASTENERS  
THE CROSS BAR TENSIONER QUICK CLIP.

Starting at the nose we suggest the following checklist (ensuring all bolts and fasteners have the appropriate thread protruding beyond the nut).

Check the nose plate assembly ensuring that the VG routing is normal. Sight along both leading edges checking for similar curves.

Walk towards the tip feeling for dents in the leading edge.

Check cross bar/leading edge junction through the zipper access.

Check sail tip lever is fully closed and the sail is not damaged.

Check the tip rod is properly located and the rear leading edge is undamaged.

Walk towards the keel checking all battens are secured.

Check the sprogs are in order and the zips are fully closed

Check the cross bar retaining shackle is secured on the quick clip.

Repeat the above steps for the other side wing in reverse order.

Check all lower rigging is correctly routed and free from damage. The most likely area for damage on wires is around the swage and thimble area.

Check Control Bar corners are correctly assembled with pip pin and cover.

Ensure the hang loop rocker is rotated 90 degrees to the keel and that hang loops are securely positioned and in good order. The hang loop should be free to move in both directions.

Check control bar top assembly and ensure that the down tubes are straight.

Unzip under surface and check cross bar hinge and restraining straps. The VG should be operated and inspected to ensure it is functioning properly.

Ensure that the double surface is zipped up and nose fairing is secure.

Clip your harness into the main and back up hang loops and perform a "hang check". Make sure that your harness is the correct distance from the base bar, your leg loops are secure and your carabina is locked.

### ***HANG GLIDER DAILY INSPECTION***

**Inspection of the following items after every assembly of the glider is required:**

Check for bends, dents, scratches in all tubes.

Check wire ends for bolt and/or other fastener security.

Check wires for twisted or jammed thimbles.

Check wires are free of kinks, frays, abrasions, broken strands etc.

Nose plate connections; spring clip retains front wires.

Tips secure; tip rod and lever undamaged, zipper closed.

Battens and bungies; springs functioning smoothly and no frays on bungies.

A frame connection on both sides; spring pins located correctly.

Variable geometry operation (full and free movement).

Rear keel connections; spring clip retains shackle and tensioner cable.

Crossbar tension wire; free of kinks, frays, abrasions, broken strands.

Crossbar operation (free floating).

Sprog tubes and rod ends and clevis pins secure.

Sail condition; no tears, symmetrical appearance.

Harness straps and webbing secure, height adjustment correct.

Emergency parachute secure, correctly mounted and attached, operating handle accessible.



**Section 7      BREAK DOWN PROCEDURE**

To break down your Climax, just reverse the set-up procedure steps as described. Included here are a few guidelines to follow which will save you time and prevent potential wear areas on your sail.

It is possible to leave the nose battens in during daily operations!

Remove nose fairing.

Unzip sprogs and rotate them towards each other. The sprogs remain outside the sail.

Remove four or five tip battens and the under surface battens.

Unload tip lever and remove tip rod.

Fold tip lever towards sail and roll sail whilst keeping tension along the trailing edge. Fit tip bags.

Let off the sail tension and pull each wing in slightly.

Pull out the remaining battens.

Attach top control bar padding.

Fold both wings in symmetrically, bringing both leading edges back at the same time or in small steps side to side.

Place padding over the keel end and rear quick clip. Place sprog covers over sprogs.

Roll the sail up parallel to the leading edge. One tie should be wrapped around the keel and leading edge to hold them together whilst the other side wing is rolled.

Ensure that the sail is rolled into the leading edge pockets. It is important that the ties are not over tensioned as this can damage the mylar insert.

Position glider bag.

Roll glider over and undo control bar pip pin. Fold base bar rearward. Attach base bar padding around down tube base. Place padding over the speed bar. Undo the two centre ties and fold the control bar down between the leading edge pockets. Lay the wires smoothly to avoid kinking. Secure the centre ties and zip up bag.

**The Climax has 1x19 wires to minimize drag. The wires are more prone to kinking and should be treated with care.**

For de-rigging flat, attach top control bar padding. Undo nose wires and pull wing forwards then follow steps as above.

If resistance is encountered during any phase of set up or break down procedure stop and investigate.

**Section 8      SHORT PACKING*****ASSEMBLE FROM SHIPPING LENGTH***

If your Glider was delivered to you in the short pack form the following procedure should be used.

Unzip bag and remove ties. Remove all padding from the tube ends.

Assemble the control frame as described in the set up procedure section. Rotate the glider on to the control bar, lying flat on the ground.

Spread both leading edges approximately ½ metre. Remove the tip bags, which have been used as protection on the rear of the front leading edges.

Check rear leading edges for R (right) and L (left). Insert rear leading edges in the appropriate side of the front leading edge. Align and push on the leading edge then rotate slightly to ensure it is located correctly. It should be impossible to rotate leading edge if correctly installed. Ensure outer sprong exits through the zipper as shown (right).



the  
the



Attach inner sprog to sprog cone with the clevis pin and locking ring as shown. For details see page 45.

You are now ready to tension the sail. There is a webbing strap attached inside the sail with small tang. Tension this tang using a small rope as a handle and attach to the rear leading edges with the self tapping screw. The tang fits into a slot milled into the end of the plastic bung, which locates the tip rod cup. Repeat for the other leading edge.



If you find the above technique to tension the sail difficult the following method can be used:

Remove the nose webbing tangs from their bolts at the nose plate.

Locate the tip webbing tangs with the screws as described previously.

Slowly spread the leading edges out. Ensure the sail is able to move forward as the leading edges are spread and is not caught on the nose pulley or damage will result.

Fit both nose battens onto the locating pins.

The cross bars can now be tensioned. Check once again the sail is OK at the nose.

Locate nose-webbing tangs to original positions then let cross bar tension off.

Your glider can now be fully assembled as outlined in the Set Up Procedure

### ***BREAKDOWN FOR SHIPPING***

Reverse the procedure above ensuring that all possible wear points are padded.

Be careful when folding the sail as the mylar leading edge insert may be damaged.

When you have finished packing the glider, place the front of the glider bag over the rear of the short packed glider. Zip up bag carefully and place the rest of the bag inside the package. (The bag is installed back to front because it is tapered and the glider is more bulky at the rear when short packed.)

## Section 10 SAIL REMOVAL AND RE-INSTALLATION

Many of the maintenance requirements outlined in this manual will require the removal of the sail from the airframe. When outlining the procedure to remove the sail we assume that you have had some experience in removing a sail from a glider. If you have not we suggest that you have some one help you that does have experience or have an authorised Airborne dealer remove and re-install the sail for you.

It is important to re-install hardware as you disassemble so that components are not misplaced.

### **REMOVING THE SAIL**

You will need a clear area of approximately 2 meters by 10 meters. A rough surface such as concrete should have a tarp laid down prior to working on the glider.

Lay the glider on the ground and unzip the bag and remove all ties. Remove the base bar from the control frame.

Remove the Phillips screw, which secure the webbing on the rear leading edge. Remove the sail tangs from the nose plate bolts. Undo the front under surface zip completely.

Remove hang loop. Undo front VG pulley bungie from sail.

Remove the rear wires and keel pocket tang from the rear quick clip.

Remove the side wires from the cross tube and pull the wires outside of the sail.

With the leading edges spread approximately ½ meter gently slide the frame forward out of the sail. Be careful that the frame hardware, particularly the cam plates and sprogs do not catch on the internal cells or velcros. **Do not force the removal of the frame otherwise damage will result.**

If the sail is to be sent to the factory for repair the transverse battens should be removed. The mylar can be left in but care should be taken not to damage the mylar when folding the sail.

## **RE-INSTALLING THE SAIL**

Install the transverse battens. Fold the sail so that the mylar pockets are together. The under surface should be on the outside. Lay the sail flat and open up the nose area slightly.

Prepare the frame by taping the sprogs so that they are folded towards each other. If possible it is best to have a cover over each leading edge as this will reduce the chances of the frame snagging on the cells or velcros.

Position the frame with the leading edges together and in the correct orientation (ie cross tubes to the top of the sail). Slowly slide the frame into the sail through the main centre zip ensuring that the tubes are forward of all velcros and cells. Make sure that the keel passes through the keel pocket. You will need to periodically check that the sail is clearing all internal cells and velcros. Be careful and slide the frame in slowly otherwise damage will result. As the frame is around half way in route the inner sprog tubes through the sprog zips. When the frame is in all the way the sail can be pulled on further at the tip to allow the rear sprogs to exit the respective zip.

After the frame is fully installed attach the rear webbing to the rear leading edge bung. When tightening the screw ensure that the tang is located in the slot. Using a piece of string on the nose webbing tension the leading edge pocket so that the tang is installed on the nose plate bolt.

Attach the front pulley bungie to the sail. Re-connect the bottom surface zip checking that the two sides are aligned. Re-tie the bungie between the eyelets so that it secures the excess zip.

Route the side wires through the sail and install them on the cross bar bolts with the side wire positioned between the VG actuating cable and the leading edge. Do not over tighten as the carbon tube can be damaged. Attach the keel pocket tang and the rear wires to the quick clip bolt. Ensure that the quick clip is oriented correctly before tightening. Make sure that the flat spring is located properly.

Attach the base tube and rotate the glider on to the control frame. Spread the wings slowly checking that nothing has fouled and that the velcros and cells are the rear side of the cross tubes.

Attach the back up hang loop around the keel and install the main loop to the rocker. Make sure that each side of the main loop passes through the slots in the under surface.

Assemble the glider completely as described earlier in the manual.

Perform a complete and thorough pre flight of the glider in accordance with the procedures outlined earlier in the manual.

## Section 11 FLIGHT TECHNIQUE

### ***TAKE OFF ..DON'T FORGET TO HOOK IN...***

The VG should be in the full off position for launching. The Climax has a slightly tail heavy static balance and is very easy to launch. Hold the nose in a slightly elevated position, approximately 20 degrees to the slope with the wings level, run hard keeping the nose at the same angle.

**It is important that the pilot accelerates smoothly during the launch run. Taking increasingly larger steps until lift off is the preferred method. Too fast an acceleration will cause the nose to rise rapidly with the risk of stall on launch.**

### ***TURNS***

The Climax can be easily directed into a turn even at slow speeds, however for a fast roll rate and easier handling, it is best to pull on a little extra flying speed.

The Climax will maintain a turn until the turn is removed by pilot input. Allow yourself plenty of margin for safety.

Don' t fly too slowly when flying close to the hill or other aircraft.

### ***STALLS***

When practising stalls make sure you have sufficient altitude. Push out slowly (approx 1 mph per sec. speed reduction), the glider will tend to mush without dropping a wing. The sink rate will increase in this mush mode more than two fold.

If you push out faster the nose will pitch higher, a gentle pitch down follows until the glider regains flying speed and recovers from the stall. A stall at full VG will result in a much more rapid pitch down and should be avoided.

Never stall the glider with the nose pitched up too high. This is a dangerous manoeuvre and can result in a tail slide and severe tumble. As a guideline, the angle at which the glider stalls results in a similar negative angle to recover.

If you push out too much in a turn the glider will turn tighter unless you are flying very slowly, in which case you may tip stall. So keep on a little extra speed in turns until you get used to the glider.

### ***SPINS***

As with all recent gliders the Climax will resist spinning. If you do stall a wing in a turn and enter the initial stages of a spin, move your weight forward and to the high side of the rotation and the glider will recover.

### **THERMALLING**

The optimum speed for thermalling is a little above stall speed; it may be necessary to fly faster than this in rough conditions to maintain good control. Depending on the nature and area of the thermal a bank angle of between 10 and 50 degrees can be used.

### **LANDING**

Landing is easy in the Climax. Your final approach should be a straight glide into the wind faster than trim speed. You should feel positive (nose up) bar pressure. The VG should be in the off position.

Reduce air speed slowly by relaxing the bar pressure smoothly. Keep wings level whilst looking straight up your runway.

When the glider reaches trim speed a full flare is required. Flare aggressively in light or no wind, holding the uprights out and up.

**It is important that the pilot does not swing the legs forward whilst flaring.** This results in the pilot's centre of gravity moving forward which will cause the nose to drop.

Upon touchdown the pilots legs must provide a gentle deceleration, coasting to a stop. (No aircraft lands well with the brakes locked on!)

In strong wind it is possible to fly the glider onto the ground slowing up gradually. Be careful not to push out too hard in windy conditions.



## Section 12 TUNING

Your Climax was test flown and delivered to you in good trim by either your dealer or by factory pilots. If, however, any adjustments are made to your glider, we recommend that they be recorded in your maintenance log at the rear of this manual.

If you feel that the glider requires adjustment to trim in the roll or pitch axis you should check that the problem is not caused by something asymmetrical in the frame or battens. In order of priority, check the following:

Ensure that the wires are correctly routed.

Check the battens against the profile.

Check that the batten bungies have the same tension on both sides. Spring battens should be checked for normal operation.

Check that the keel is straight.

Check that the sail is correctly mounted on the leading edges.

Checks that both sprog assemblies are not damaged.

Check leading edges are straight and the rear leading edges are located correctly.

### ***PITCH TRIM***

To make the glider trim faster move the main hang strap forward and to trim slower move the hang loop rearward. The hang loop should be adjusted one hole at a time.

A heavier pilot may make the glider trim slower than a lighter pilot. The heavier pilot causes an increase in twist through extra leading edge flex. Minor changes in hang loop position should be used to fine-tune the glider for the particular pilot.

### ***PITCH STABILITY SYSTEM***

Stability in the pitch axis is provided by maintaining twist outboard of the cross bar leading edge junction. Internal washout struts (sprogs) are used to maintain a minimum amount of twist to maintain the required level of pitch stability. Correct attachment and adjustment of the sprogs is essential for maximum stability. **Do not lower your sprogs below the factory standard settings. Lowering your sprogs will result in reduced pitch stability**

Alterations to the lengths of rigging, airframe or adjustments to the airfoil can also have adverse effects on pitch stability.

### ***CHECKING THE CLIMAX STABILITY SYSTEM***

The Climax has a compensated internal sprog. As the VG pulls the sail flatter the Inboard sprog automatically lowers with the trailing edge. To confirm that the sprogs are correctly set the VG must be in a definitive position.

The method used checks the sprog angle relative to the root angle of the glider. This method is simpler to use than a string line on the trailing edge and is very accurate if the correct procedure is used.

### ***PREPARING THE TEMPLATE***

A template is supplied in the rear of the manual, which is used to check the sprog settings.

Cut accurately along the top dotted line. It is important that the cut is accurate as this edge is lined up with the sprogs and determines the relative angle to the keel.

Cut a piece of cardboard to the same size as the paper and glue the template to the cardboard. Thick cardboard of around 3-5mm is best. Once again it is important to accurately cut the top edge.

Glue the paper template to the cardboard with the top edges accurately aligned.

Punch a small hole at the top left hand corner of the template where marked.

A piece of 2mm string around 1 meter long with a small weight is used as the "plum bob". The string is passed through the hole with a knot on the rear side of the template to secure the line.

### ***CHECKING THE SPRONG ANGLES***

Fully assemble the glider on a flat even surface.

Set the VG as shown on the diagram on the set up template. The inner sprog compensation requires this setting to be accurate.

Use a stand or step ladder to achieve a zero keel angle (horizontal). The glider should be supported as close as possible to the rear wires so that the rear keel tube is not bending under the gliders own weight.

Align the top of the template to the front of the 42 mm keel tube just behind the step down section. The string line should line up with the **vertical** line once the keel is perfectly horizontal. Secure the keel so that the glider will not rotate around the control frame once the zero angle is achieved. Re-check the angle.

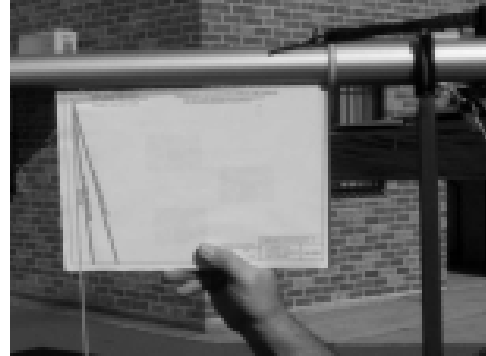

The sprog tubes can move span wise within the red webbings, which will cause discrepancies in the angle readings. The sprog tubes should be pushed to the tip side of the webbing prior to checking as this produces the lowest angle.



Place the template under the sprog tube. Push up enough so that the side flying wire goes tight and check the string is aligned with the appropriate line on the template.

To adjust the angle fold the sprog out and remove the clevis pin at the front of the tube. Rotate the threaded cone anti clockwise to raise the rear of the sprog. Rotate the threaded cone clockwise to lower the rear of the sprog.

### ***ROLL/YAW TRIM***

Turns in your gliders occur when the glider is asymmetrical. If you have a turn in your glider you should confirm that the 7 possible variables outlined at the beginning of this section have been checked.

The glider may have a turn due to several factors. If the turn only appears at VG settings from ½ on to full on it is generally an indication that the sprogs are not set symmetrically.

The following tables outline procedures for adjustments. Adjustments should be made to the glider in the sequence as shown. The glider should be tuned firstly in the VG off setting and then checked VG on. If necessary the sprogs must be tuned as outlined in the second table.

**NOTE:** We refer to the fast wing as the wing on the high side of the turn ie. The right wing is the fast wing if the wing is turning left and vice versa.

**ROLL TRIM ADJUSTMENTS**

ADJUSTMENTS WHEN THE GLIDER IS CONFIGURED VG OFF TO 1/2 ON			
	ADJUSTMENT METHOD	Remedy left turn	Remedy right turn
MILD TURN	<p><b>DIFFERENTIAL LEADING EDGE TENSION</b> The tip levers have small inserts as shown on the drawing (Fig 1). To remedy a mild turn the sail tip screw should be removed and the insert on both sides rotated 180 deg as shown in figure 1, page 29. The tip levers should be reattached to the sail to adjust a turn as outlined. Specific settings are referred to in the table following the tip lever adjustment drawing. Adjust 3-4mm per side initially.</p>	Attach the sail to the <b>left tip</b> lever to <b>increase</b> the sail tension. Attach the sail to the <b>right tip</b> lever to <b>decrease</b> the sail tension.	Attach the sail to the <b>right tip</b> lever to <b>increase</b> the sail tension. Attach the sail to the <b>left tip</b> lever to <b>decrease</b> the sail tension.
	<p><b>TIP PLUG ADJUSTMENT (TIP UP).</b> If further adjustment is required the tip angle on the fast wing is raised. The tip plug can be rotated to raise or lower the tip angle on either wing. To raise the tip angle on the fast wing access the fibreglass tip bung through the zip at the end of the leading edge tube. Remove the Philips screw and adjust as outlined. The standard setting is 2 holes from the zero hole for the C2-13 and 1 hole for the C2-14. The fitting should not be adjusted more than two holes from the standard position per adjustment. Reinstall the screw once adjustment is made.</p>	Rotate the <b>right tip</b> fitting <b>anti clockwise</b> if viewed from the rear of the leading edge one hole at a time.	Rotate the <b>left tip</b> fitting <b>clockwise</b> if viewed from the rear of the leading edge one hole at a time.
MORE SIGNIFICANT TURN	<p><b>TIP PLUG ADJUSTMENT (TIP DOWN)</b> If the turn persists the tip angle can be lowered on the slow wing. Access the fibreglass tip bung through the zip at the end of the leading edge tube. Remove the Philips screw and adjust as outlined. The standard setting is as above. The fitting should not be adjusted more than two holes from the standard position per adjustment. Reinstall the screw once adjustment is made.</p>	Rotate the <b>left tip</b> fitting <b>anti clockwise</b> if viewed from the rear of the leading edge one hole at a time.	Rotate the <b>right tip</b> fitting <b>clockwise</b> if viewed from the rear of the leading edge one hole at a time.
	<p><b>REAR SECTION ADJUSTMENT.</b> If the turn still persists after the tip plug rings have been rotated the front leading edge step down rear eccentric ring can be adjusted. The angle that the rear section protrudes from the front section can be altered by rotation of the outer eccentric (plastic) ring. The location of this ring is fixed with a small screw. Remove screw and reinstall once adjustment is made.</p>	Use the "Y" tool to rotate the <b>right</b> step down ring <b>anti-clockwise</b> if viewed from the rear of the leading edge one hole. This raises the RHS rear leading edge	Use the "Y" tool to rotate the <b>left</b> step down ring <b>clockwise</b> if viewed from the rear of the leading edge one hole. This raises the LHS rear leading edge
If the glider tends to turn the opposite direction after the rear section adjustment the tip plugs should be adjusted to straighten the glider.			

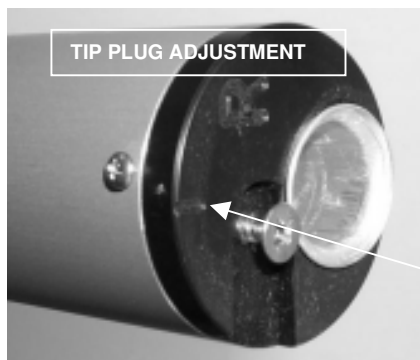

RHS rear leading edge shown

LOCATING PIN  
REFERENCE LINE



RHS leading edge step-down shown

**TIP LEVER ADJUSTMENT**

FIGURE 1

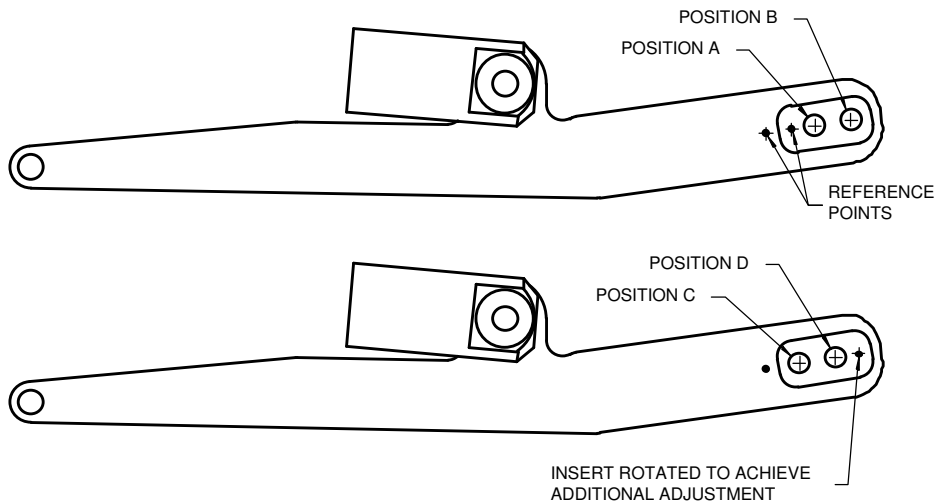

The following table shows standard sail position and variations to the standard setting. Note that there are two "standard" positions. Check the glider serial number prior to making any adjustments.

APPLICABLE GLIDER	STANDARD POSITION	ADJUSTMENTS
CL13-97 and after CL14-53 and after	Position D	Position A -4mm Position B +3mm Position C -7mm
Prior to CL13-97 Prior to CL14-53	Position A	Position B +7mm Position C -3mm Position D +4mm

**SPROG ADJUSTMENT FOR SYMMETRY**

ADJUSTMENTS WHEN THE GLIDER IS CONFIGURED 1/2 ON TO FULL ON			
	ADJUSTMENT METHOD	Remedy for left turn	Remedy for right turn
MILD TURN	OUTBOARD SPROG ADJUSTMENT. The glider should be assembled with the VG off. Unzip the outer sprog and fold forward. Remove the ring and clevis pin from the front of the sprog tube. Make appropriate adjustment and install clevis pin and ring. Install sprog.	Raise the right sprog by rotating the cone anticlockwise by 1/2 turn.	Raise the left sprog by rotating the cone anticlockwise by 1/2 turn.
	OUTBOARD SPROG ADJUSTMENT. If the glider still turns the opposite sprog can be lowered as described.	Lower the left sprog by rotating the cone clockwise by 1/2 turn.	Raise the left sprog by rotating the cone anticlockwise by 1/2 turn.

If after following the procedure as outlined above the glider still tends to roll one way please contact your AirBorne dealer or call the AirBorne factory.

## HANDLING AND PERFORMANCE TUNING

The following table is designed to allow a pilot to reference methods of tuning the Climax to suit the individual. Varying wing loading will affect the way the glider behaves in pitch and roll trim. For example, a heavier loaded glider will tend to increase the flex in the leading edge tube causing more washout. This increase in washout will tend to make the glider more spirally stable. A lightly loaded glider will tend to be less spirally stable requiring more high siding from the pilot.

Adjustments are described assuming that the glider is straight and all adjustments are symmetrical.

TUNING	HANDLING	PERFORMANCE	BAR PRESSURE
CENTER OF GRAVITY	Increase in pitch pressure when CG moved rearward.	No change	Increase in pitch pressure when CG moved rearward.
	Decrease in pitch pressure when moved forward.	No change	Decrease in pitch pressure when moved forward.
TIP PLUGS Rotating the tip plug ref. line down results in an increase in glass tip angle ie Left tip ring clockwise & Right tip ring anticlockwise.	Rotating the <b>tip plugs down</b> reduces high siding on a bank	Slightly reduced performance	Increase in bar pressure
	Rotating the <b>tip plugs up</b> increases the amount of high siding required	Slightly better performance	Reduction in bar pressure
INNER RING Rotating the inner rings down results in an increase in the leading edge dihedral ie Left leading edge inner ring clockwise & Right leading edge inner ring anti clockwise	Rotating the <b>inner ring down</b> reduces high siding on a bank	Does not effect performance	No Change with small adjustments
	Rotating the <b>inner ring up</b> increases the amount of high siding required	Does not effect performance	No Change with small adjustments
LEADING EDGE TENSION Refer to Fig 1 to vary leading edge tension settings	<b>Increase</b> in leading edge tension slows roll rate	A slight increase may improve performance but over tensioning will cause the tip to bend up effectively reducing performance	No Change with small adjustments
	<b>Decrease</b> in leading edge tension improves roll rate	Loss of performance if tension is reduced to the point where the leading edge starts to deform	No Change with small adjustments

## Section 13 PERIODIC INSPECTIONS and MAINTENANCE

### MAINTENANCE SCHEDULE

1 – Clean and service, 2 – Check as directed, 3 – Check for security, cracks, wear and faulty operation, 4 Remove, inspect and replace if necessary, 5 Recommend replacement or overhaul.

MAINTENANCE REQUIREMENT	Maintenance Period							
	Period >	Daily	Monthly	Three Months	Six Monthly	Every Year	Every 2 Years	Every 4 Years
	Flying Days >	1	10	30	50	100	200	400
Wing Fabric deterioration and tears			2	2	2	2	4	5
Wing Fabric Stitching			2	2	2	2	2	
Wing Fabric attachment points			3	3	3	3	3	3
Batten Spring Fittings & Elastics			3	3	3	3	4	4
Check Battens against template supplied				2	2	2	2	2
Wing wires and attachment fittings, including sprog wires	2		3	3	4	5	5	5
Check leading edges, keel & A Frame for straightness, dents and corrosion	2		2	2	2	4	4	4
Check leading edges, keel & A Frame structural members and check for fatigue cracks radiating from drilled holes.	2		2	2	2	4	4	4
Check centre junction and carbon spars (See notes)	2		2	2	2	4	4	4
Check cross tube leading edge junction (Remove hinge bolt and inspect bushes, bolt and hole)	2		2	2	2	3	3	3
					4	5	5	5
Check sprog assemblies including rod ends, clevis pins etc	2		2	2	2	2	2	2
Check Inspection Zips			2	2	2	2	2	2
Check Variable Geometry, pulleys and cleats	2		3	3	3	4	4	5
All bolts, nuts, washers & safety pins. At least one thread showing outside each nut.	2		2	2	2	2	2	2
Check hang straps and karabiners for wear or damage	2		2	2	2	4	5	5
Check Saddles and fittings for cracks			2	2	2	4	4	5

It is recommended that:

Items marked 1,2 and 3 should be performed by the owner of the glider;

Items marked 4 be performed by the owner in conjunction with another pilot; and

Items marked with a 5 be performed by **Airborne** or an accredited **Airborne** service agent.

### LOG BOOK

When maintenance is performed always check appropriate square and make an entry in the maintenance log at the rear of this manual.

## **NOTES ON PERIODIC INSPECTIONS**

### **AIRFRAME TUBING**

#### **Installation & Removal**

When removing tubing do not bend or force tubes. If resistance is encountered stop and check for the cause. Do not force the tube.

#### **Inspection**

Inspect tubing for cracks, damage from abrasion, elongated holes or distortion in tube surface. Never attempt to repair tubing, always replace with new part. Inspect tubing for corrosion in and out. If corrosion is present the component should be replaced.

#### **Replacement**

Aluminium tube comes in many different sizes and grades. It is important that the correct replacement parts are used.

### **CARBON CROSS TUBES**

#### **Installation & Removal**

To comprehensively check the carbon spars and junction the sail should be removed from the airframe as outlined in this manual.

#### **Inspection**

The carbon cross tubes should be thoroughly inspected for cracks. The aluminium plug, which is bonded into the carbon tube at the centre section, should also be thoroughly checked for damage or cracking at the bond line. A torch should be used to check that the tubes show no signs of damage on the inside.

### **BOLTS**

#### **Installation & Removal**

After tightening, all bolts should have at least one and a half to two threads showing. All self-locking nuts should not be installed more than two times. Be sure not to over torque bolts when installing.

#### **Inspection**

Check bolts for worn shanks, bad threads or corrosion.



## SAILS

**Sail Inspection**

Check for tears in the sailcloth or any loose or unravelled seams.  
Check all inspection zippers to see if they function smoothly and close completely.  
Inspect tip webbing for damage.

Sail may be repaired with appropriate sail tape or a sewn on patch. **Airborne** or an authorised agent should be consulted about sail repairs. Keep the sail clean of oil and dirt by washing the sail with soap and water. Keep the sail covered when not in use.

**CONTINUED EXPOSURE TO SUN DRAMATICALLY SHORTENS THE LIFE OF SAILS** - possibly to as little as six months.

***INSPECTION AFTER HARD LANDING***

It is necessary to do a detailed inspection following any unusual stressing of the Hang Glider this full inspection should include all details listed for the six monthly maintenance.

The inspection should be noted in the logbook, and any replacement to be recorded.

***DEFECT REPORTS***

Details of any defect which develops in service and which, if kept uncorrected, would compromise the continued safe operation of the hang glider should be reported to **Airborne** as soon as practicable.

## **Section 14      TRANSPORTATION AND STORAGE**

Avoid damage to your glider by using well padded racks. Careless transportation can cause considerable damage to your glider.

We recommend that you support the glider in at least 3 places to spread the load. The glider should be transported with the control frame down to minimise the chance of damage to the cross tubes.

Flat straps should be used for tie downs to avoid damage to leading edge mylar.

Store the glider in a dry room off the ground. Air the glider out regularly to avoid mildew, and never store wet.

**SAFE FLYING**

**TEAM AIRBORNE**



## Section 16 HANG GLIDER COMPLIANCE SCHEDULES

### GLIDER MODEL: CLIMAX 13

**MANUFACTURED BY: AIRBORNE WINDSPORTS Pty Ltd**

NOTE: These specifications are intended only as a guideline for determining whether a given glider is a certified model and whether it is in the certified configuration.

Be aware, however, that no set of specifications, however detailed, can guarantee the ability to determine whether a glider is the same model, or is in the same configuration as was certified, or has those performance, stability, and structural characteristics required by the certification standards. An owner' s manual is required to be delivered with each HGMA certified glider, and it is required that it contain additional airworthiness information.

	Metric	Imperial
Weight of glider with all essential parts and without cover bags and non essential parts.	33 kg	73 lbs
<b>Leading Edge Dimensions</b>		
Nose Plate anchor hole to crossbar attachment hole	3080 mm	121.26"
Nose Plate anchor hole to rear sail attachment point	5490 mm	216.14"
Outside diameter at nose	60 mm	2.36"
Outside diameter at cross bar	62 mm	2.44"
Outside diameter at rear sail attachment point	12 mm	1.77"
<b>Crossbar Dimensions</b>		
Overall pin to pin length from leading edge attachment point to hinge bolt at glider centre line	2871 mm	113.03"
Largest outside diameter	75 mm	2.95"
<b>Keel dimensions</b>		
The cross bar centre load bearing pin	760 mm	29.92"
The pilot hang loop	Fwd Rear	1275 mm 1305 mm
		50.20" 51.38"
<b>Sail Dimensions</b>		
Chord length at 3 ft outboard of centre line	1620 mm	63.78"
Chord length at 3 ft inboard of tip	1020 mm	40.18"
Span (extreme tip to tip)	9600 mm	377.95 "
<b>Location of Information Placard</b>	Front Keel	
<b>Location of Test Fly Sticker</b>	Front Keel	
<b>Recommended Pilot Hook in Weight Range</b>	55-90 kg	121-198 lbs
<b>Recommended Pilot Proficiency</b>	Advanced	

NB: Conversions \* 0.4536 kg/pound \* 25.4 mm/inch \* 1.609km / mile

**GLIDER MODEL: CLIMAX 14****MANUFACTURED BY: AIRBORNE WINDSPORTS Pty Ltd**

NOTE: These specifications are intended only as a guideline for determining whether a given glider is a certified model and whether it is in the certified configuration.

Be aware, however, that no set of specifications, however detailed, can guarantee the ability to determine whether a glider is the same model, or is in the same configuration as was certified, or has those performance, stability, and structural characteristics required by the certification standards. An owner' s manual is required to be delivered with each HGMA certified glider, and it is required that it contain additional airworthiness information.

	<b>Metric</b>	<b>Imperial</b>
Weight of glider with all essential parts and without cover bags and non essential parts.	36 kg	79. lbs
<b>Leading Edge Dimensions</b>		
Nose Plate anchor hole to crossbar attachment hole	3375 mm	132.87"
Nose Plate anchor hole to rear sail attachment point	5955 mm	234.45"
Outside diameter at nose	60 mm	2.36"
Outside diameter at cross bar	62 mm	2.44"
Outside diameter at rear sail attachment point	12 mm	0.47"
<b>Crossbar Dimensions</b>		
Overall pin to pin length from leading edge attachment point to hinge bolt at glider centre line	3141 mm	123.66"
Largest outside diameter	75 mm	2.95"
<b>Keel dimensions</b>		
The cross bar centre load bearing pin	845 mm	33.27"
The pilot hang loop	Fwd 1360 mm Rear 1390 mm	53.54" 54.72"
<b>Sail Dimensions</b>		
Chord length at 3 ft outboard of centre line	1780 mm	70.08"
Chord length at 3 ft inboard of tip	1120 mm	44.09"
Span (extreme tip to tip)	10400 mm	409.45"
<b>Location of Information Placard</b>	Front Keel	
<b>Location of Test Fly Sticker</b>	Front Keel	
<b>Recommended Pilot Hook in Weight Range</b>	75-120 kg	176-298 lbs
<b>Recommended Pilot Proficiency</b>	Advanced	

NB: Conversions \* 0.4536 kg/pound \* 25.4 mm/inch \* 1.609km/mile

**Section 17 SPROG ANGLE TEMPLATES**

GLIDER MODEL: CLIMAX 13

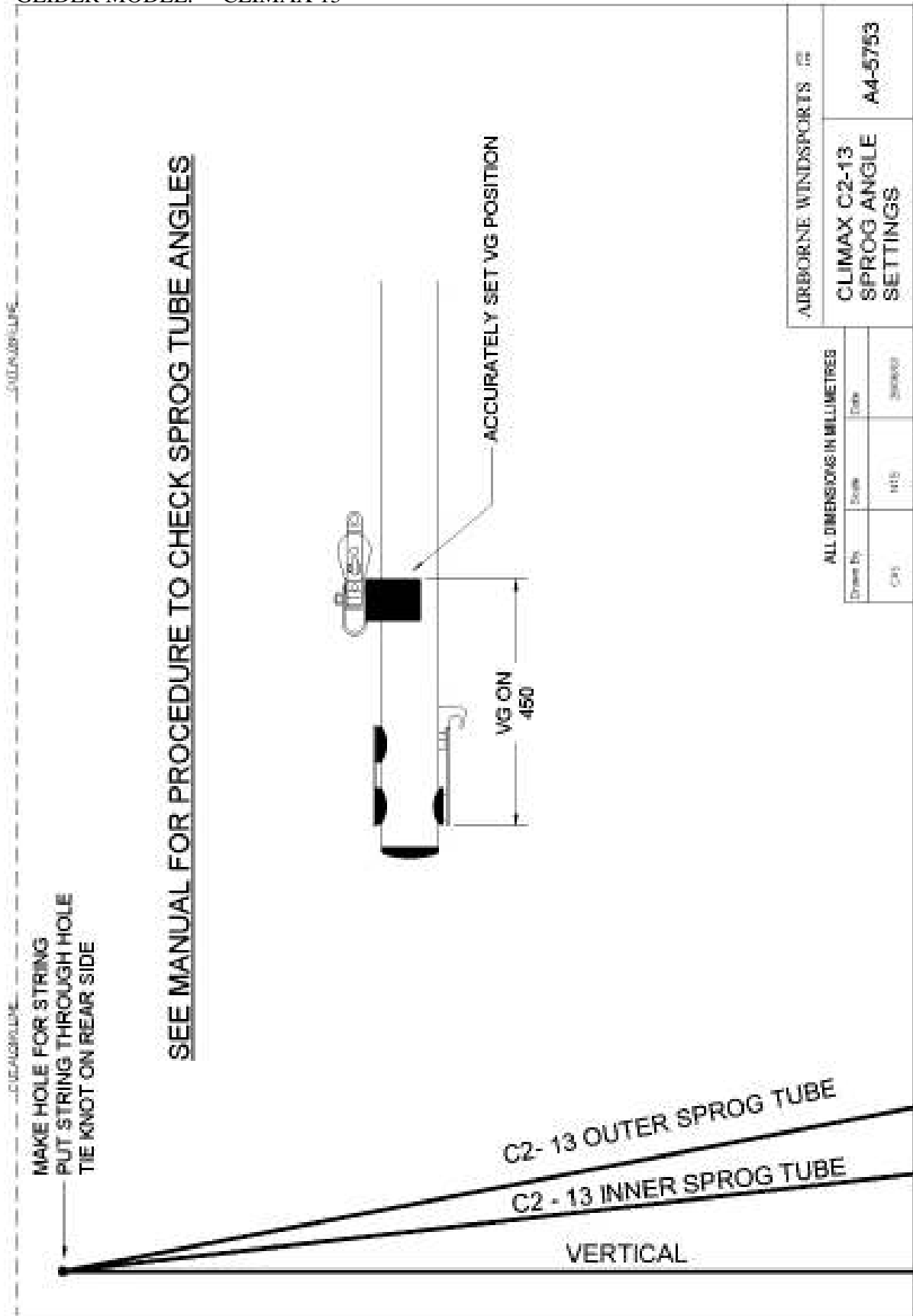

AIREBORNE WINDSPORTS		CLIMAX C2-13 SPROG ANGLE SETTINGS		A4-5753	
Drawn By:	Scale:	Date:			
CHS	1:1.5	20/08/04			

ALL DIMENSIONS IN MILLIMETRES

GLIDER MODEL: CLIMAX 14

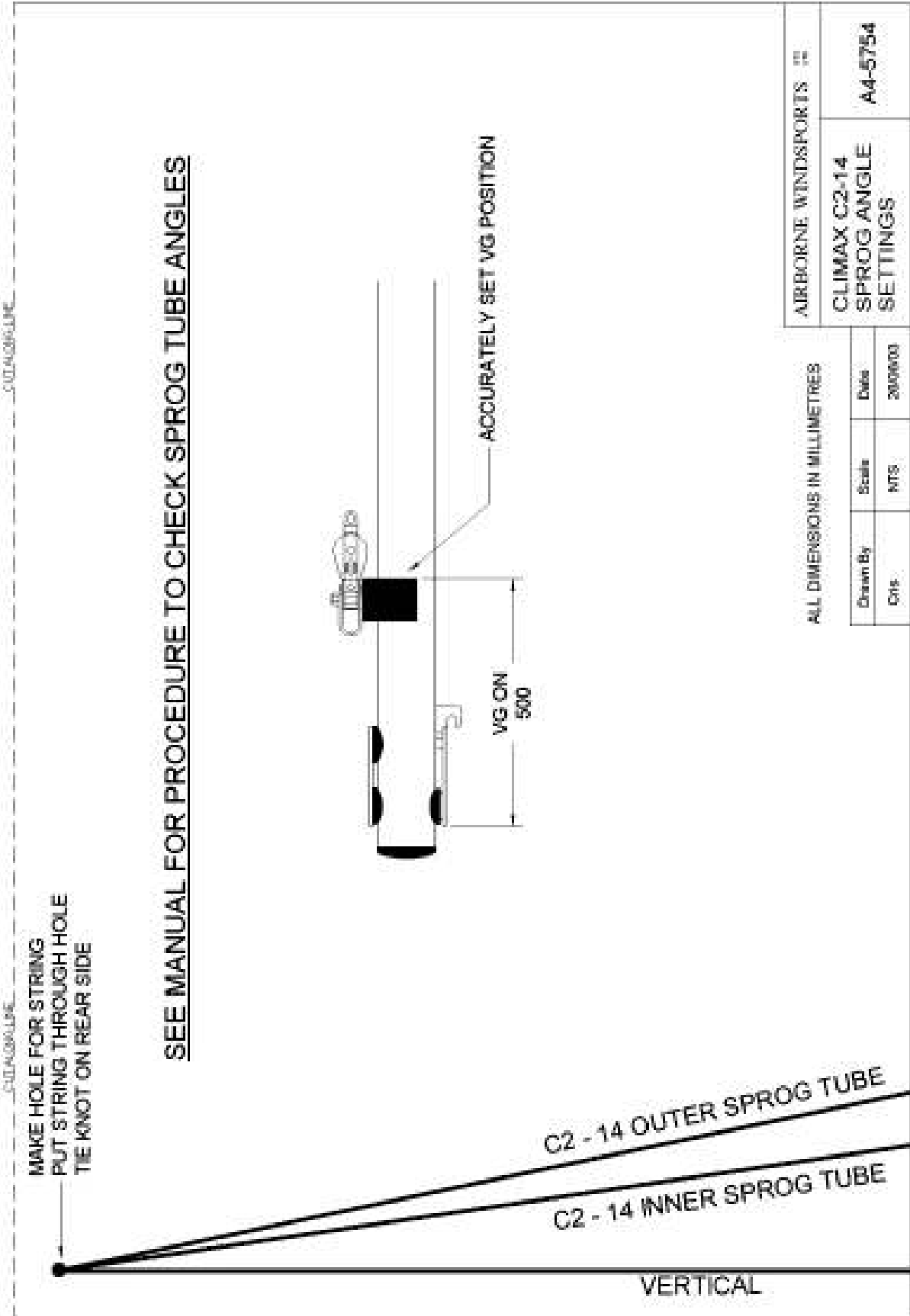

## Section 18 ASSEMBLY DRAWINGS

### Climax II Center Section Assembly Type 2

Climax II Center Section Assembly Type 2				
Dwg No A4-5348 23/06/2003				
Id	Part No	Details	C2-13 FRAME	C2-14 FRAME
1	106172	SKT BUTTON SCREW M5 X 10	10.000	10.000
2	104231	CIRCLIP X/BAR PIN	4.000	4.000
3	104973	X/BAR HINGE PLATE CLIMAX II	2.000	2.000
4	104226	X/BAR CLIMAX 13	2.000	
	104227	X/BAR CLIMAX 14		2.000
5	104244	X/BAR HINGE PIN CLIMAX	2.000	2.000
6	104270	X/BAR WEDGE CLIMAX	1.000	1.000
7	105040	X/BAR WEDGE REAR SLIDER	1.000	1.000
9	104284	X/BAR HINGE PLATE SLIDER	1.000	1.000
10	101064	SHOCK CORD 3MM	0.550	0.550
11	100003	AN4-11A	1.000	1.000
12	100547	AN4-12A	1.000	1.000
13	104749	CLIMAX II X-BAR JUNCTION WASHER	4.000	4.000
14	105045	X/BAR WEDGE STRAP REAR TYPE 2	1.000	1.000
15	100035	AN4 NUT HALF NYLOC	2.000	2.000
16	100584	AN3-13A BOLT	1.000	1.000
17	104285	X/BAR WEDGE STRAP FRONT	1.000	1.000
18	100049	AN3 WASHER	2.000	2.000
19	101334	AN3 NUT HALF NYLOC	1.000	1.000
20	105036	PULL BACK WIRE CLIMAX C2 13	2.000	
	105037	PULL BACK WIRE CLIMAX C2 14		2.000
21	102021	SHACKLE PULL BACK	1.000	1.000
22	105110	PULL BACK ASSEMBLY 2:1 CL2 13	1.000	
	105111	PULL BACK ASSEMBLY 2:1 CL2 14		1.000
23	105107	THIMBLE BUSH OD18	1.000	1.000
24	101169	HEATSHRINK CLEAR 20	0.050	0.050
25	104416	HEATSHRINK CLEAR 25	0.060	0.060
26	104823	REAR KEEL COVER CLIMAX II	1.000	1.000



**Climax II Center Section Assembly A4-5348**

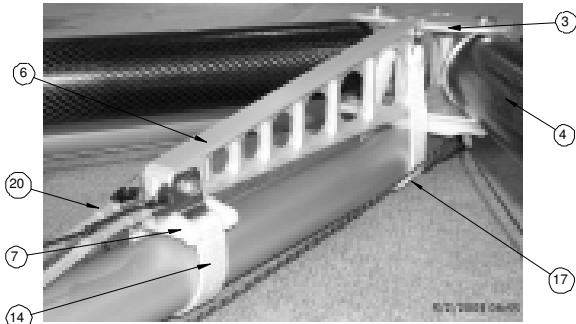

Side View From Back End of Assembly

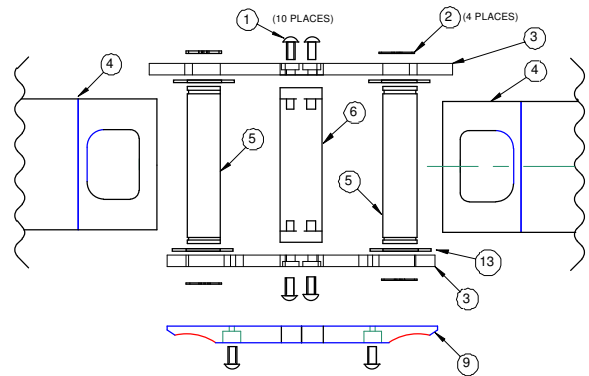

Front View

CLIMAX CENTER SECTION  
ASSEMBLY SEE A4-4826

CLIMAX II CENTER SECTION ASSEMBLY  
SEE A4-5241 FOR GLIDERS UP TO:  
C2 13 SERIAL NO. 160  
C2 14 SERIAL NO. 111

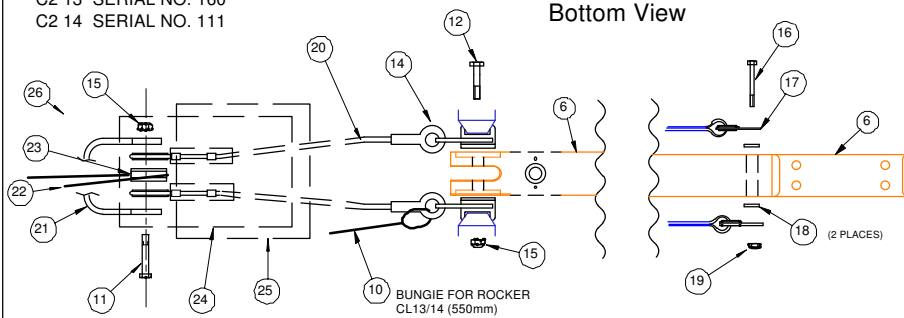

Bottom View

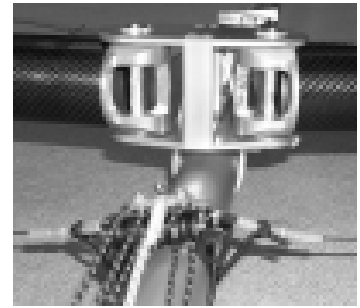

**Climax II Center  
Section Assembly Type 2**

Rev	AMENDMENT	Date

CLIMAX II 13 FRAME #104747  
CLIMAX II 14 FRAME #104748

Drawn By	Scale	Date
CRIS	NTS	17/01/03

**A4-5348**  
SHEET 1 OF 1

## Climax II VG Assembly

<b>Climax II VG Assembly</b>				
Dwg No A4-5242 23/06/2003				
<b>Id</b>	<b>Part No</b>	<b>Details</b>	<b>C2-13 FRAME</b>	<b>C2-14 FRAME</b>
1	101334	AN3 NUT HALF NYLOC	2.000	2.000
2	104303	VG PULLEY SLIDER PLATE	1.000	1.000
3	104757	CLIMAX II 13 VG PULLEY ROPE	1.000	
	104758	CLIMAX II 14 VG PULLEY ROPE		1.000
4	104305	SHACKLE DRILLED RF615	2.000	2.000
5	104277	VG PULLEY SLIDER	1.000	1.000
6	101064	SHOCK CORD 3MM	0.300	0.300
7	102927	AN3-10A BOLT	2.000	2.000
8	100406	SHACKLE RF615	1.000	1.000
9	104761	Part No NOT Found	2.000	2.000
10	104222	SPECTRA ROPE 3MM	7.900	7.900
11	104257	CAM WIRE CLIMAX 13	2.000	
	104259	CAM WIRE CLIMAX 14		2.000
12	101064	SHOCK CORD 3MM	0.300	0.300
13	101488	BUSH 10 DX 6L	1.000	1.000

**Climax VG Assembly A4-5242**

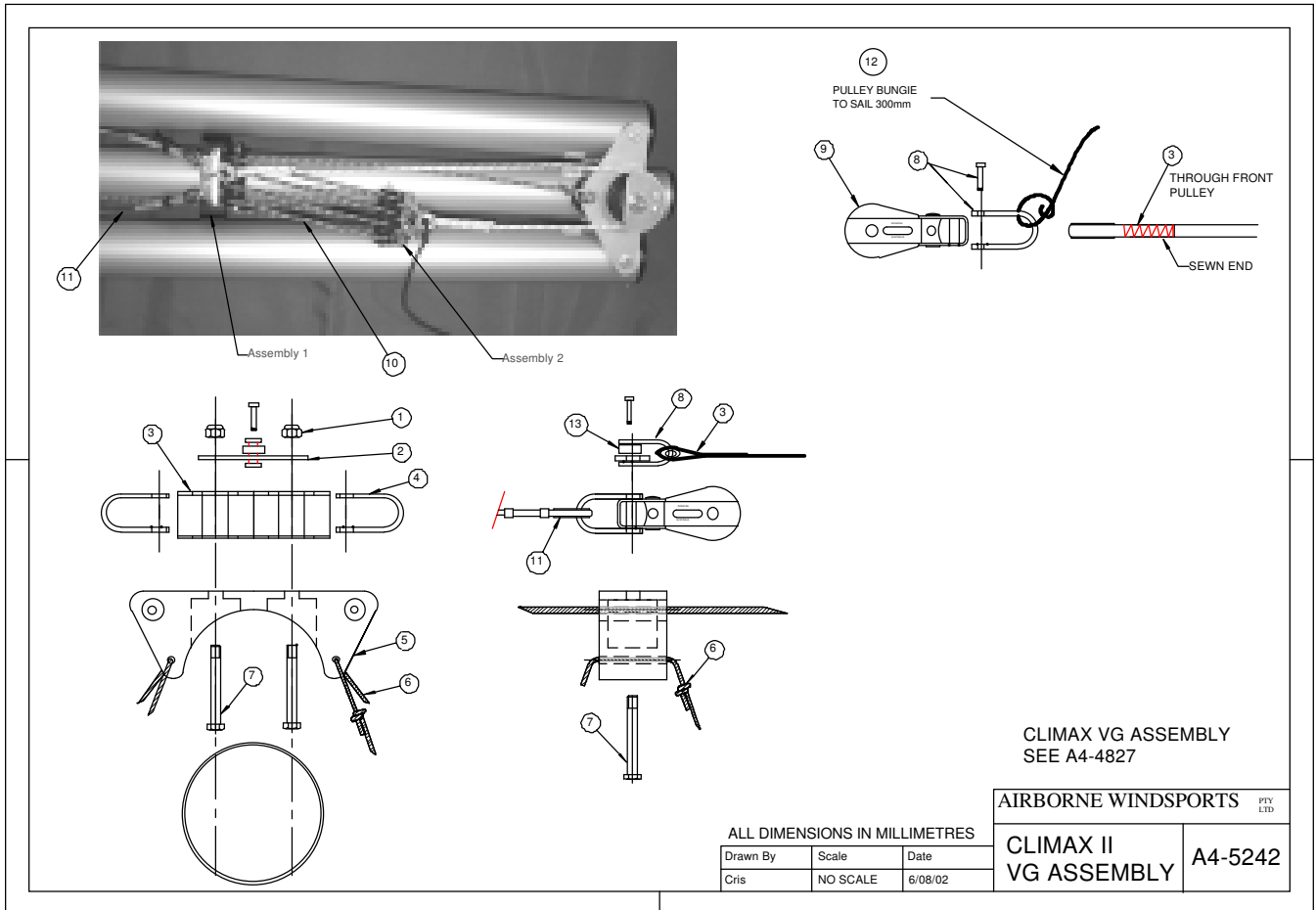

## Climax Cross Bar Leading Edge Assembly

<b>Climax Cross Bar Leading Edge Assembly</b>				
Dwg No A4-4824 23/06/2003				
<b>Id</b>	<b>Part No</b>	<b>Details</b>	<b>C2-13 FRAME</b>	<b>C2-14 FRAME</b>
2	100549	AN4-22A	2.000	2.000
3	104485	SPROG ASSEMBLY INBOARD CLIMAX 13	2.000	
	104486	SPROG ASSEMBLY INBOARD CLIMAX 14		2.000
4	100035	AN4 NUT HALF NYLOC	4.000	4.000
5	101055	NYLON WASHER M 6 XOD	2.000	2.000
7	100037	AN5 NUT HALF NYLOC	2.000	2.000
8	102018	WASHER SS 1/4 X 3/4"	4.000	4.000
9	100080	SADDLE TO SUIT 60MM TUBE	2.000	2.000
10	104483	BUSH X/BAR CLIMAX	2.000	2.000
11	100022	AN5-31A	2.000	2.000
12	104508	COVER MYLAR SAIL PROTECTOR CLIMAX	2.000	2.000
13	101064	SHOCK CORD 3MM	0.400	0.400
14	104249	SPROG CONES 25MM TUBE CLIMAX	1.000	1.000
15	100950	LOCKING RING 12MM RF114	2.000	2.000
16	104209	CLEVIS PIN 3/16"X 1 1/32"	2.000	2.000
17	104294	CAM COVER CLIMAX	2.000	2.000
18	104489	BOLT MODIFIED AN4-22A	2.000	2.000
19	100624	MYLAR WASHER	2.000	2.000
20	100043	AN5 WASHER	2.000	2.000

**Climax X-Bar Leading Edge Assembly A4-4824**

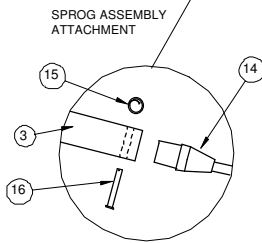
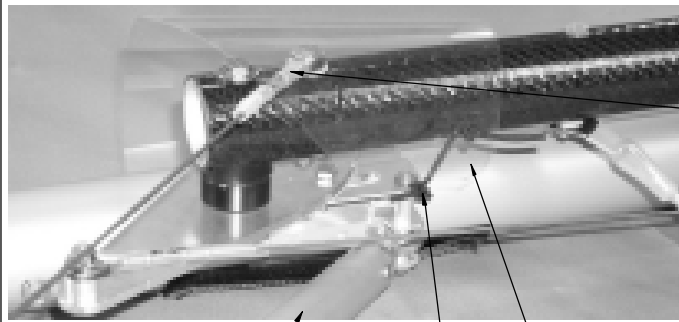

VG PLATE COVER

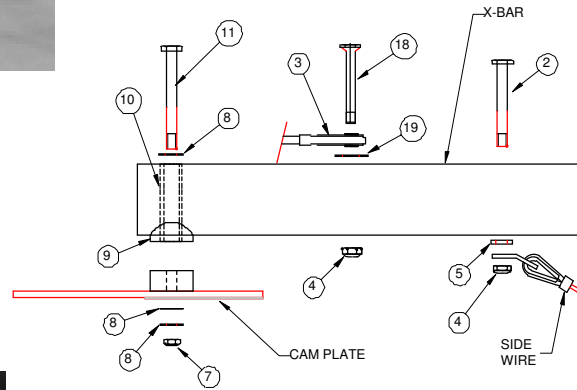
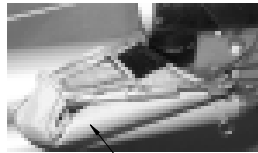

Rev	AMENDMENTS	DATE
1	#20 ADDED	10/09/01
2	WASHER. NO. UPDATE. CLIMAX II ADDED	15/08/02

ALL DIMENSIONS IN MILLIMETRES  
UNLESS STATED OTHERWISE

CLIMAX II 13 FR	ASSEM. PART #104747
CLIMAX II 14 FR	ASSEM. PART #104748
CLIMAX 13	ASSEM. PART #104278
CLIMAX 14	ASSEM. PART #104279

**Climax X Bar L/Edge Assembly**

Drawn By	Scale	Date
SIMON	NTS	21/01/01

**A4-4824**  
SHEET 1 OF 1

## Climax Cam Junction Assembly

<b>Climax Cam Junction Assembly</b>				
Dwg No A4-4981 23/06/2003				
<b>Id</b>	<b>Part No</b>	<b>Details</b>	<b>C2-13 FRAME</b>	<b>C2-14 FRAME</b>
1	100160	POP RIVET 3/16 SHORT (6-4)	6.000	6.000
2	104268	SPROG-X/BAR BRACKET LHS CLIMAX	1.000	1.000
	104269	SPROG-X/BAR BRACKET RHS CLIMAX	1.000	1.000
3	104180	L/EDGE FRONT CLIMAX 14	1.000	1.000
	104233	L/EDGE FRONT CLIMAX 13	1.000	1.000
4	104497	CRESCENT REDUCER OUTER CLIMAX	2.000	2.000
6	102713	ROLL PIN 3/32" X 1/2" SS	1.000	1.000
7	105140	SCREW SELF TAPPING 1/4X8G 304SS	2.000	2.000
8	100950	LOCKING RING 12MM RF114	2.000	2.000
9	104228	L/EDGE SLEEVE 52 ASSEM CLIMAX	2.000	2.000
	104821	L/EDGE SLEEVE ASSEM CL II LITE	1.000	1.000
10	104207	CLEVIS PIN 3/16"X 2 15/32"	2.000	2.000
11	100035	AN4 NUT HALF NYLOC	6.000	6.000
12	104555	SPROG ROD END INTERNAL SPACER LONG	2.000	2.000
13	104288	ALUMINIUM SPACER FOR VG CAM CLIMAX	2.000	2.000
14	104516	VG CAM PLATE ASSEMBLY	2.000	2.000
15	100001	AN4- 7A	2.000	2.000
16	100587	AN4-24A	2.000	2.000
17	104554	SPROG ROD END INTERNAL SPACER SHORT	2.000	2.000
18	104249	SPROG CONES 25MM TUBE CLIMAX	2.000	2.000
19	104216	ROD END 5/16" UNF MALE	2.000	2.000
20	104301	SPROG ROD END EXTERNAL SPACER	2.000	2.000
22	104447	VELCRO 25MM LOOP/BLACK ADHESIVE	0.200	0.200
23	102018	WASHER SS 1/4 X 3/4"	4.000	4.000
24	101055	NYLON WASHER M 6 XOD	4.000	4.000
25	100002	AN4- 6A	2.000	2.000
26	100034	AN4 NUT FULL NYLOC	2.000	2.000
27	100012	AN4-32A	2.000	2.000

**Climax Cam Junction Assembly A4-4981**

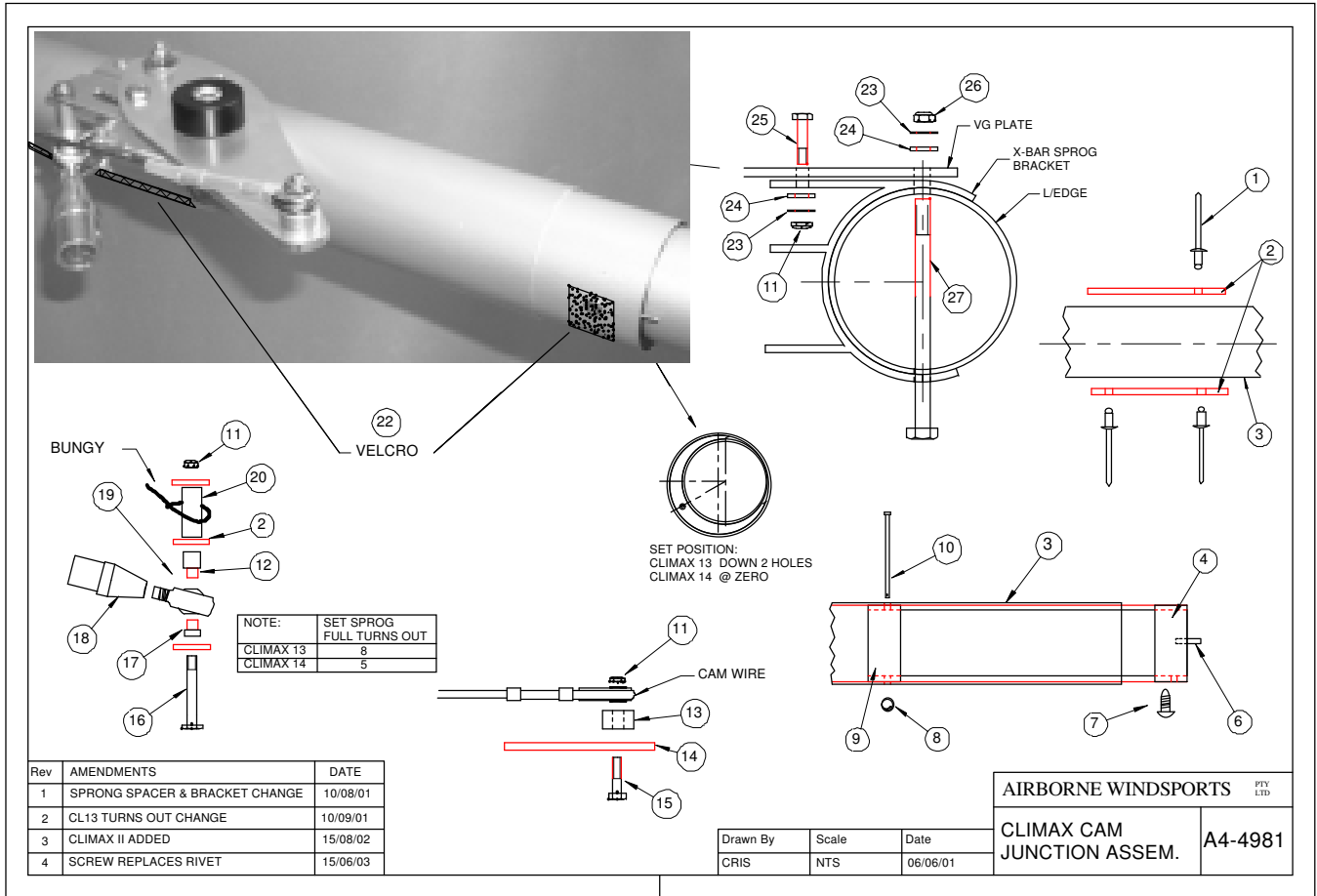

## Climax Nose Junction Assembly

<b>Climax Nose Junction Assembly</b>				
Dwg No A4-4828 23/06/2003				
<b>Id</b>	<b>Part No</b>	<b>Details</b>	<b>C2-13FRAME</b>	<b>C2-14FRAME</b>
1	100631	AN4-31	2.000	2.000
2	102273	AN4-41A	1.000	1.000
3	104491	BOLT MODIFIED AN4-30A	1.000	1.000
4	104274	NOSE PLATE HG TYPE 2 4MM BOTTOM	1.000	1.000
5	104273	NOSE PLATE HG TYPE 2 4MM TOP	1.000	1.000
6	100042	AN4 WASHER	8.000	8.000
7	100035	AN4 NUT HALF NYLOC	3.000	3.000
8	104180	L/EDGE FRONT CLIMAX 14		2.000
	104233	L/EDGE FRONT CLIMAX 13	2.000	
9	104178	KEEL TUBE ASSEM FRONT CLIMAX 14		1.000
	104255	KEEL TUBE ASSEM FRONT CLIMAX 13	1.000	
10	100820	NYLON WASHER M 8 XOD	1.000	1.000
11	102271	SADDLE TO SUIT 45MM TUBE	3.000	3.000
12	101455	WASHER SS 1/4 X 1"	1.000	1.000
13	104280	VG PULLEY COVER ASSEMBLY	1.000	1.000
14	104212	PULLEY 50MM BEARING RF1767	1.000	1.000
15	104275	SPRING QUICK CLIP GATE	1.000	1.000
16	104520	NOSE CLIP TYPE 3	1.000	1.000
17	100034	AN4 NUT FULL NYLOC	1.000	1.000
18	104276	QUICK CLIP BLOCK TYPE 3	1.000	1.000
19	104503	NOSE SAFETY CATCH	1.000	1.000
20	102424	NYLON WASHER 1/4" OBA THICK	1.000	1.000
21	103290	TANG 1/4" EYELET HOLE	1.000	1.000



**Nose Junction Assembly A4-4828**

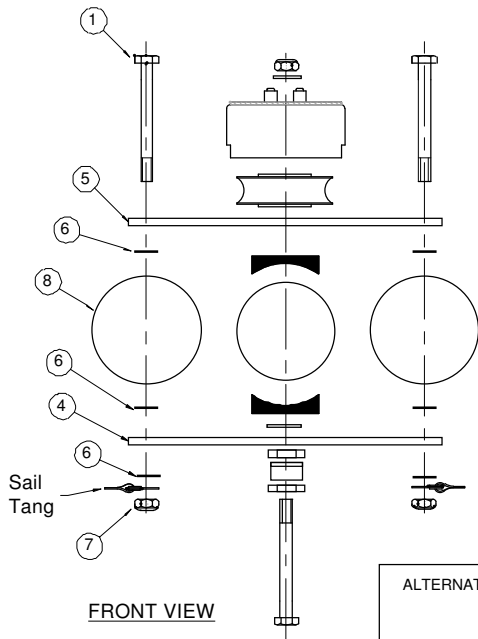

Sail Tang

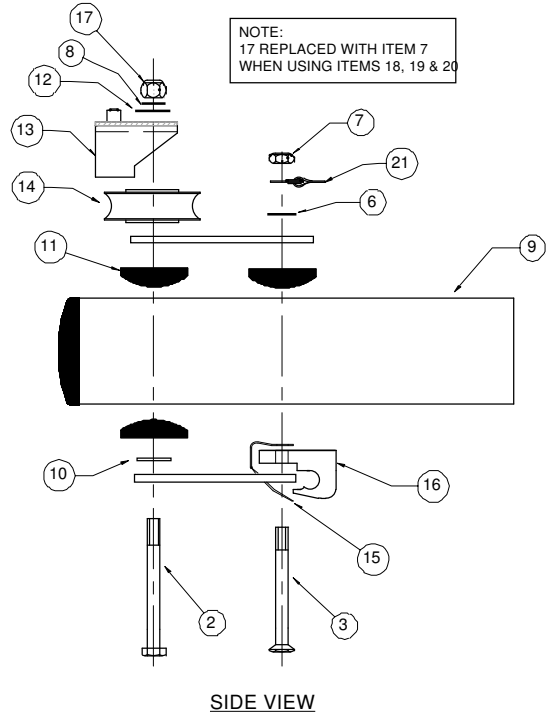
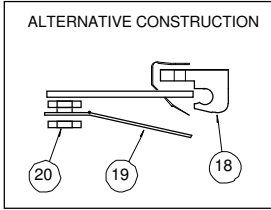

NOTE:  
17 REPLACED WITH ITEM 7  
WHEN USING ITEMS 18, 19 & 20

Rev	AMENDMENTS	Date
1	INCLUDE WASHER #8	25/05/02
2	CLIMAX II ADDED, #13 UPDATE	15/08/02
3	TANG #21 ADDED	15/06/03

**ALL DIMENSIONS IN MILLIMETRES**

Drawn By	Scale	Date
Rick	NTS	18/01/01

<b>AIRBORNE WINDSPORTS</b> PTY LTD	
CLIMAX NOSE JUNCTION ASSEMBLY	A4-4828

## Climax Rear Keel Assembly

<b>Climax rear Keel Assembly</b>				
Dwg No A4-4829 23/06/2003				
<b>Id</b>	<b>Part No</b>	<b>Details</b>	<b>C2-3FRAME</b>	<b>C2-14FRAME</b>
1	100037	AN5 NUT HALF NYLOC	1.000	1.000
2	104310	HANG LOOP NYLON RETAINER	2.000	2.000
3	100820	NYLON WASHER M 8 XOD	2.000	2.000
4	104183	HANG LOOP PILLAR SPREADER	1.000	1.000
5	104500	AN5-46	1.000	1.000
6	100012	AN4-32A	1.000	1.000
7	104184	HANG LOOP PILLAR BASE	1.000	1.000
8	100080	SADDLE TO SUIT 60MM TUBE	1.000	1.000
9	100042	AN4 WASHER	2.000	2.000
10	100035	AN4 NUT HALF NYLOC	2.000	2.000
11	100161	POP RIVET 5/32 MED(5-5)	3.000	3.000
12	104215	PULLEY CHEEK BLOCK RIVET MNT	1.000	1.000
13	104252	PULLEY BRACKET VG CLIMAX	1.000	1.000
14	100003	AN4-11A	1.000	1.000
15	101055	NYLON WASHER M 6 XOD	2.000	2.000
16	104276	QUICK CLIP BLOCK TYPE 3	1.000	1.000
17	104275	SPRING QUICK CLIP GATE	1.000	1.000
18	100009	AN4-26A	1.000	1.000
19	100034	AN4 NUT FULL NYLOC	1.000	1.000
21	102379	ENDCAP FOR 42MM TUBE LUG WITH HOLE	1.000	1.000
22	104313	KEEL BUNG CLIMAX	1.000	1.000
23	104291	PULL BACK STRAP WITH TANGS	1.000	1.000
24	101064	SHOCK CORD 3MM	1.050	1.250
25	101064	SHOCK CORD 3MM	1.250	1.400
26	100162	POP RIVET 1/8	2.000	2.000
27	105179	HANG LOOP PILLAR SPACER C2	1.000	1.000

**Climax Rear Keel Assembly A4-4829**

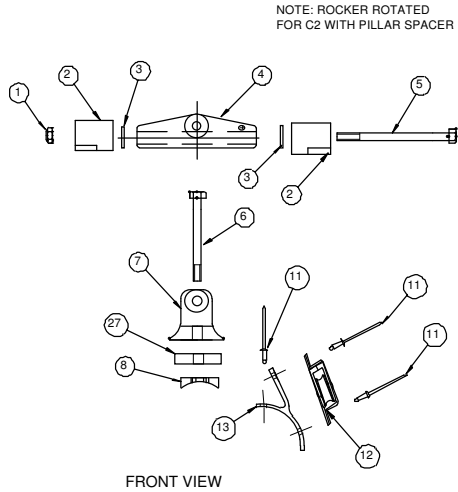

NOTE: FOR PARTS ASSEMBLY SEE A-FRAME ASSEM. (A4-7237)

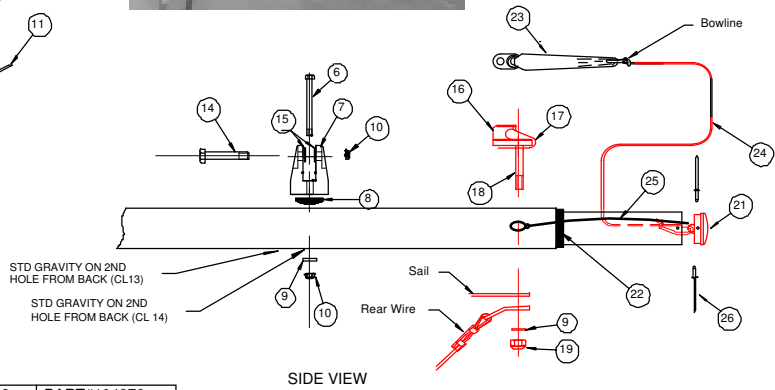

Rev	AMENDMENTS	Date
1	STD GRAVITY NOTE & #26 ADDED	02/09/01
2	STD GRAVITY NOTE REVISED	27/11/01
3	CLIMAX II ADDED	15/08/02
4	ROCKER ROTATED, SPACER, 14 ADDED	03/06/03

CL13	PART#104278
CL14	PART#104279
CL II 13	PART#104747
CL II 14	PART#104748

ALL DIMENSIONS IN MILLIMETRES

Drawn By	Scale	Date
Rick	NTS	18/01/01

AIRBORNE WINDSPORTS PTY LTD	
CLIMAX REAR KEEL ASSEMBLY	A4-4829

## HG AFrame Faired Corner Unit Assembly Type 2

HG AFrame Faired Corner Unit Assembly Type 2								
Dwg No A4-7237 23/06/2003								
Id	Part No	Details	C2-13 M-DRAG	C2-14 M-DRAG	C2-13	C2-13 S-LINE	C2-14	C2-14 S-LINE
1	101339	D/TUBE A/FOIL SILVER 1700		-2.000				-2.000
	103957	D/TUBE A/FOIL SILVER 1700 SLEEVED					2.000	
	300010	D/TUBE A/FOIL SILVER 1650	-2.000		2.000	-2.000		
2	101743	D/TUBE BTM KNUCKLE FAIRED AB LHS	-1.000	-1.000	1.000	-1.000	1.000	-1.000
3	101742	D/TUBE BTM KNUCKLE FAIRED AB RHS	-1.000	-1.000	1.000	-1.000	1.000	-1.000
4	101713	C/BAR KNUCKLE HG TYPE 2			2.000		2.000	
5	104402	SIDE BOTT WIRE CL13 AB/SLINE FRAME	-2.000			-2.000		
	104403	SIDE BOTT WIRE CL14 AB/SLINE FRAME		-2.000				-2.000
	104809	SIDE BOTT WIRE CL14 2 AB/SLINE FRAM					2.000	
	104912	SIDE BOTT WIRE CL2-13 AB/SLINE FRAM			2.000			
6	101745	BOLT M6 D/TUBE BOTTOM KNUCKLE	-2.000	-2.000	2.000	-2.000	2.000	-2.000
7	102010	VG ROLLER	-1.000	-1.000	1.000	-1.000	1.000	-1.000
13	102015	SPRING CLIP 1 PIN TYPE 1	-2.000	-2.000	2.000	-2.000	2.000	-2.000
14	101055	NYLON WASHER M 6 XOD	-4.000	-4.000	4.000	-4.000	4.000	-4.000
16	104406	FRNT FLYING WIRE CL13 AB FRAME	-1.000		1.000	-1.000		
	104407	FRNT FLYING WIRE CL14 AB FRAME		-1.000				-1.000
	104808	CLII 14 AB FRAME FRONT WIRE					1.000	
17	104408	REAR FLYING WIRE CL13 AB FRAME	-1.000			-1.000		
	104409	REAR FLYING WIRE CL14 AB FRAME		-1.000				-1.000
	104750	REAR FLYING WIRE CLII 13 AB FRAME			1.000			
	104752	REAR FLYING WIRE CLII 14 AB FRAME					1.000	
18	106172	SKT BUTTON SCREW M5 X 10	-4.000	-4.000	4.000	-4.000	4.000	-4.000
19	100055	WASHER SS 3/16 X 7/16" 304 FLAT	-4.000	-4.000	4.000	-4.000	4.000	-4.000
20	106171	A FRAME LOCK SHAFT 20MM	-2.000	-2.000	2.000	-2.000	2.000	-2.000
21	100035	AN4 NUT HALF NYLOC	-1.000	-1.000	1.000	-1.000	1.000	-1.000
22	100042	AN4 WASHER	-1.000	-1.000	1.000	-1.000	1.000	-1.000
23	101757	SPEED BAR TYPE 2 1400 WITH CLEAT	-1.000	-1.000	1.000	-1.000	1.000	-1.000
24	101333	AN4-13A	-1.000	-1.000	1.000	-1.000	1.000	-1.000
25	106050	PIP PIN 33 WITH CAP	-1.000	-1.000	1.000	-1.000	1.000	-1.000
26	102015	SPRING CLIP 1 PIN TYPE 1		-2.000			2.000	-2.000
27	100023	AN5-32A		-1.000			1.000	-1.000
28	100036	AN5 NUT FULL NYLOC		-1.000			2.000	-1.000
29	103999	D/TUBE TOP KNUCKLE FAIRED HG TYPE 1	-2.000	-2.000	2.000	-2.000	2.000	-2.000
30	102332	WASHER SS 5/16 X 3/4"	-2.000	-2.000	2.000	-2.000	2.000	-2.000
31	104476	BEARING AB VG CORNER PULLEY 6X10X3	-2.000	-2.000	2.000	-2.000	2.000	-2.000

**HG A-Frame Faired Corner Unit Assembly Type AB A4-7237**

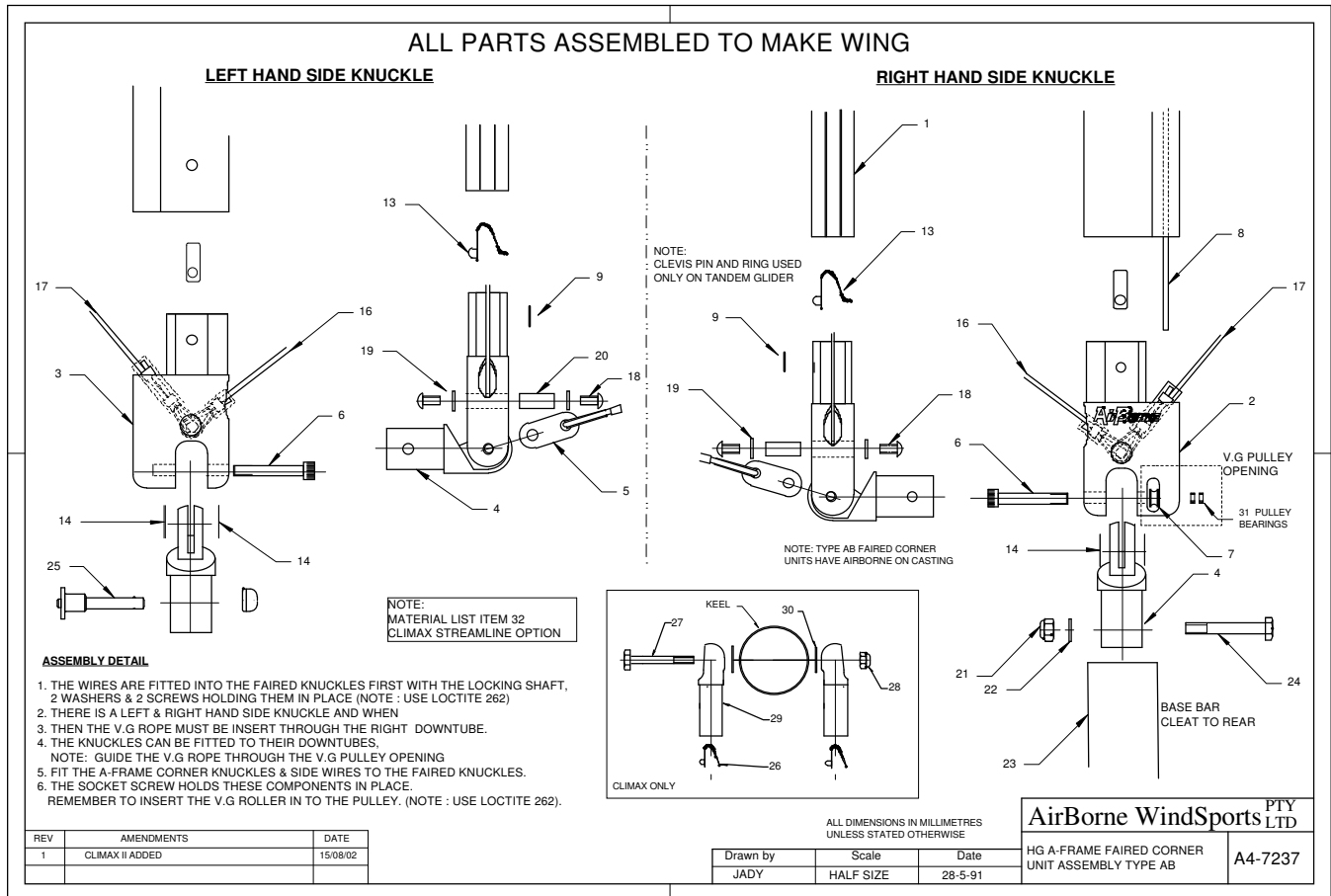

## STREAMLINE CONTROL FRAME

STREAMLINE CONTROL FRAME								
Dwg No A4-4983 23/06/2003								
Id	Part No	Details	C2_13	C2_14	CL13_S LINE	CL14_S LINE	RETRO_ CL13	RETRO_ LC14
1	104479	FRNT FLYING WIRE CL13 STRMLNE/MICRO	1.000	1.000	1.000	1.000	1.000	1.000
	104480	FRNT FLY WIRE CL14 STLNE & C214 MIC				1.000		1.000
	104807	CLII 14 STREAMLINE FRONT WIRE		1.000				
2	104222	SPECTRA ROPE 3MM	1.000	1.000	1.000	1.000	1.000	1.000
3	104481	SPEED BAR STREAMLINE 1380	1.000	1.000	1.000	1.000	1.000	1.000
4	102148	PIP PIN 38 WITH CAP	2.000	2.000	2.000	2.000	2.000	2.000
5	104553	BOLT M6 STREAMLINE BOTTOM KNUCKLE	2.000	2.000	2.000	2.000	2.000	2.000
6	104475	BEARING STRMLINE VG 4.7X12.7X5	1.000	1.000	1.000	1.000	1.000	1.000
7	104474	BEARING PIN STREAMLINE FRAME	1.000	1.000	1.000	1.000	1.000	1.000
8	104524	NYLON WASHER 15X1	2.000	2.000	2.000	2.000	2.000	2.000
9	104402	SIDE BOTT WIRE CL13 AB/SLINE FRAME			1.000			
	104403	SIDE BOTT WIRE CL14 AB/SLINE FRAME				1.000		1.000
	104809	SIDE BOTT WIRE CL14 2 AB/SLINE FRAM		1.000				
	104912	SIDE BOTT WIRE CL2-13 AB/SLINE FRAM	1.000				1.000	
10	102015	SPRING CLIP 1 PIN TYPE 1	2.000	2.000	2.000	2.000	2.000	2.000
11	100950	LOCKING RING 12MM RF114	2.000	2.000	2.000	2.000	2.000	2.000
12	104572	CLEVIS PIN 3/16" X 29/32"	2.000	2.000	2.000	2.000	2.000	2.000
13	104457	D/TUBE STREAMLINE SILVER 1700				2.000		2.000
	104458	D/TUBE STREAMLINE SILVER 1650	2.000		2.000		2.000	
	104810	D/TUBE STREAMLINE SILVER 1750		2.000				
14	104751	REAR FLYING WIRE CLII 13 STREAMLINE	1.000	1.000	1.000	1.000	1.000	1.000
	104753	REAR FLYING WIRE CLII 14 STREAMLINE		1.000		1.000		1.000
15	100022	AN5-31A	1.000	1.000	1.000	1.000	1.000	1.000
16	102332	WASHER SS 5/16 X 3/4"	2.000	2.000	2.000	2.000	2.000	2.000
18	100037	AN5 NUT HALF NYLOC	1.000	1.000	1.000	1.000	1.000	1.000
19	102015	SPRING CLIP 1 PIN TYPE 1	2.000	2.000	2.000	2.000	2.000	2.000
20	104308	D/TUBE TOP KNUCKLE STREAMLINE HG	2.000	2.000	2.000	2.000	2.000	2.000
21	104462	D/TUBE BTM KNUCKLE STREAMLINE RHS	1.000	1.000	1.000	1.000	1.000	1.000
22	104460	C/BAR KNUCKLE HG STREAMLINE RHS	1.000	1.000	1.000	1.000	1.000	1.000
23	104461	D/TUBE BTM KNUCKLE STREAMLINE LHS	1.000	1.000	1.000	1.000	1.000	1.000
24	104459	C/BAR KNUCKLE HG STREAMLINE LHS	1.000	1.000	1.000	1.000	1.000	1.000

**Streamline Control Frame A4-4983**

ID	DESCRIPTION	DWG	P/NO	REQD

**RIGHT HAND SIDE  
DOWN TUBE ASSEM.**

**LEFT HAND SIDE  
DOWN TUBE ASSEM.**

**FRONT VIEW**

**INTERNAL PARTS**

CLIMAX 13	PART #104446
CLIMAX 14	PART #104521
CLIMAX II 13	PART #104446
CLIMAX II 14	PART #104521

Rev	AMENDMENTS	Date
1	CLIMAX II ADDED	15/08/02

**ALL DIMENSIONS IN MILLIMETRES  
UNLESS STATED OTHERWISE**

Drawn By	Scale	Date
CRIS	NTS	04/06/01

<b>AIRBORNE WINDSPORTS</b>	
STREAMLINE CONTROL FRAME ASSEMBLY	<b>A4-4983</b>

## Micro-Drag Control Frame Assembly

<b>Micro-Drag Control Frame Assembly</b>				
Dwg No A4-5317 23/06/2003				
<b>Id</b>	<b>Part No</b>	<b>Details</b>	<b>C2_13 MicroDRAG</b>	<b>C2_14 MicroDRAG</b>
1	104479	FRNT FLYING WIRE CL13 STRMLNE/MICRO	1.000	
	104480	FRNT FLY WIRE CL14 STLNE & C214 MIC		1.000
2	104972	MICRO-DRAG CARBON BASE BAR ASSEMBLY	1.000	1.000
3	104222	SPECTRA ROPE 3MM	1.000	1.000
4	104958	MICRO-DRAG BASE BAR PIT PIN	1.000	1.000
6	104945	SIDE BOTT WIRE CL13-2 MICRODRAG FRM	2.000	
	104946	SIDE BOTT WIRE CL14-2 MICRODRAG FRM		2.000
8	100950	LOCKING RING 12MM RF114	2.000	2.000
9	104572	CLEVIS PIN 3/16" X 29/32"	2.000	2.000
10	104947	REAR FLYING WIRE CL13-2 MICRODRAG		1.000
	104948	REAR FLYING WIRE CL14-2 MICRODRAG	1.000	
11	104884	D/TUBE MICRODRAG SILVER 1680	2.000	
	104885	D/TUBE MICRODRAG SILVER 1730		2.000
12	100024	AN5-33A	1.000	1.000
13	102332	WASHER SS 5/16 X 3/4"	2.000	2.000
14	100037	AN5 NUT HALF NYLOC	1.000	1.000
15	104966	CLEVIS PIN OD3.9X20L	4.000	4.000
16	104967	CLEVIS PIN RING OD9X0.6T	4.000	4.000
17	104970	MICRO-DRAG TOP DT KNUCKLE RHS	1.000	1.000
18	104971	MICRO-DRAG TOP DT KNUCKLE LHS	1.000	1.000
20	104962	MICRO-DRAG LOWER DT KNUCKLE LHS	1.000	1.000
	104963	MICRO-DRAG LOWER DT KNUCKLE RHS	1.000	1.000
21	104964	MICRO-DRAG SS BUSH OD8X21.5L	2.000	2.000
22	104968	TUFFNOL ROLLER OD14.5XID8.1XW6.1	1.000	1.000
23	104965	MICRO-DRAG SS BUSH OD6X15.7L	2.000	2.000



**Mirco-Drag Control Frame Assembly A4-4317**

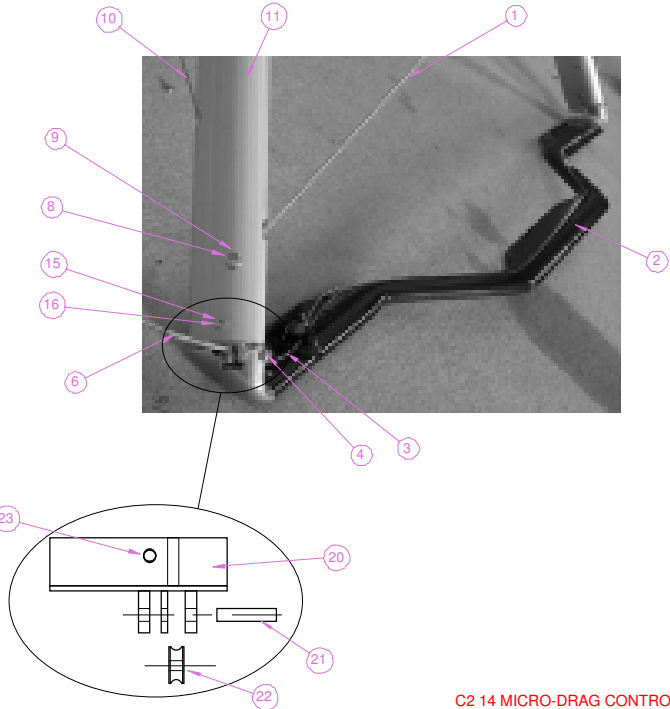

ID	DESCRIPTION	DWG	P/NO	REQD
1	FRONT FLYING WIRES		104479 / 104480	1
2	MICRO-DRAG BAS BAR ASSEMBLY		104972	1
3	VG ROPE		104222	*
4	PIT PIN		104958	*
5				
6	SIDE WIRES		104945 / 104946	2
7				
8	CLEVIS PIN LOCKING RING		100950	2
9	CLEVIS PIN 3/16"x29/32"		104572	2
10	REAR FLYING WIRES		104947 / 104948	1
11	MICRO-DRAG DOWN TUBES		104884 / 104885	2
12	AN5-33 BOLT		100024	1
13	SS WASHER 5/16"x3/4"		102332	2
14	AN5 HALF NUT NYLOC		100037	1
15	CLEVIS PIN OD3.9x20L		104966	4
16	CLEVIS LOCKING RING		104967	4
17	TOP DT KNUCKLE RHS		104970	1
18	TOP DT KNUCKLE LHS		104971	1
20	LOWER DT KNUCKLES		104962 / 104963	1
21	SS BUSH OD8x21.5L		104964	2
22	TUFFNOL ROLLER		104968	1
23	SS BUSH OD6x15.7L		104965	2

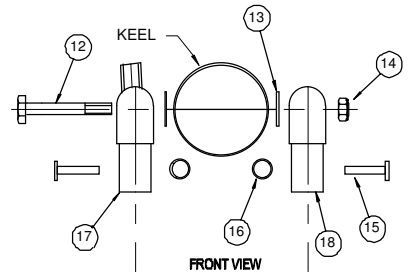
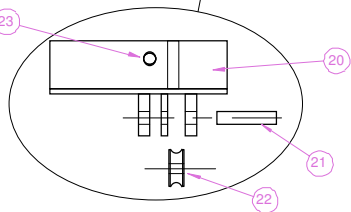

C2 14 MICRO-DRAG CONTROL FRAME ASSEM  
PART NO. 104949  
C2 13 MICRO-DRAG CONTROL FRAME ASSEM  
PART NO. 104950

Rev	AMENDMENTS	Date

ALL DIMENSIONS IN MILLIMETRES UNLESS STATED OTHERWISE

Drawn By	Scale	Date
Cris	NTS	9/12/2002

AIRBORNE WINDSPORTS		PTY LTD
<b>MICRO-DRAG CONTROL FRAME ASSEMBLY</b>		<b>A4-5317</b>

## Climax Rear L/Edge Assembly

<b>Climax Rear L/Edge Assembly</b>						
Dwg No A4-4825 23/06/2003						
<b>Id</b>	<b>Part No</b>	<b>Details</b>	<b>CL13LHS</b>	<b>CL13RHS</b>	<b>CL14LHS</b>	<b>CL14RHS</b>
1	100035	AN4 NUT HALF NYLOC	2.000	2.000	2.000	2.000
2	104487	SPROG ASSEMBLY OUTBOARD CLIMAX 13	1.000	1.000		
	104488	SPROG ASSEMBLY OUTBOARD CLIMAX 14			1.000	1.000
3	104251	SPROG BRACKET OUTBOARD	1.000	1.000	1.000	1.000
4	104202	MACH SCREW MS24694-S106 1/4X1 7/32"	1.000	1.000	1.000	1.000
5	104490	BOLT MODIFIED AN4-26A	1.000	1.000	1.000	1.000
6	100950	LOCKING RING 12MM RF114	2.000	2.000	2.000	2.000
7	104210	CLEVIS PIN 3/16" X 25/32"	1.000	1.000	1.000	1.000
8	104509	COVER MYLAR SPROG CLIMAX	1.000	1.000	1.000	1.000
9	104301	SPROG ROD END EXTERNAL SPACER	2.000	2.000	2.000	2.000
10	104250	SPROG CONES 19MM TUBE CLIMAX	1.000	1.000	1.000	1.000
11	104447	VELCRO 25MM LOOP/BLACK ADHESIVE	0.075	0.075	0.075	0.075
12	104216	ROD END 5/16" UNF MALE	1.000	1.000	1.000	1.000
13	102424	NYLON WASHER 1/4" OBA THICK	1.000	1.000	1.000	1.000
14	104315	SCREW PHILIPS PAN 4GX6MM	1.000	1.000	1.000	1.000
15	104245	BUNG FIBREGLASS TIP RHS		1.000		1.000
	104246	BUNG FIBREGLASS TIP LHS	1.000		1.000	
16	100912	SCREW 10X3/4 305 CSK PHIL	1.000	1.000	1.000	1.000
17	104247	BUNG TUBE FIBREGLASS TIP	1.000	1.000	1.000	1.000
18	104208	CLEVIS PIN 3/16" X 2 1/32"	1.000	1.000	1.000	1.000
19	104229	L/EDGE REAR CLIMAX RHS		1.000		1.000
	104248	L/EDGE REAR CLIMAX LHS	1.000		1.000	
20	104610	TIP BUNG BUSH	1.000	1.000	1.000	1.000

**Climax Rear Leading Edge Assembly A4-4825**

**Assembly 1**

**BUNG SET-UP**

LOCATING SCREW  
BUNG MARK OFFSET:  
C2-13, 2 HOLES DOWN  
C2-14, 1 HOLE DOWN

**RHS**

LOCATING SCREW  
BUNG MARK OFFSET:  
C2-13, 2 HOLES DOWN  
C2-14, 1 HOLE DOWN

**LHS**

**F/Glass Tip Fitting**

**Outboard Sprog Assembly**

**Assembly 2**

Rev	AMENDMENTS	Date
1	#20 ADDED	13/09/01
2	BUNG OFFSET CHANGE C2-14	13/06/03

ALL DIMENSIONS IN MILLIMETRES

Drawn By	Scale	Date
SIMON	NTS	25/01/01

AIRBORNE WINDSPORTS PTY LTD	
CLIMAX REAR L/E ASSY.	A4-4825

## Dive Strut Assembly

<b>Sprog Assembly Climax</b>						
Dwg No A4-4978 23/06/2003						
<b>Id</b>	<b>Part No</b>	<b>Details</b>	<b>CL13IN</b>	<b>CL13OUT</b>	<b>CL14IN</b>	<b>CL14OUT</b>
1	104295	SPROG TUBE OUTBOARD CLIMAX 13		1.000		
	104296	SPROG TUBE INBOARD CLIMAX 13	1.000			
	104297	SPROG TUBE OUTBOARD CLIMAX 14				1.000
	104298	SPROG TUBE INBOARD CLIMAX 14			1.000	
2	104260	SPROG WIRE INNER CL14			1.000	
	104261	SPROG WIRE OUTER CL14				1.000
	104262	SPROG WIRE INNER CL13	1.000			
	104263	SPROG WIRE OUTER CL13		1.000		
3	104416	HEATSHRINK CLEAR 25	0.175	0.125	0.160	0.180
4	100561	EDGE MOULDING	0.070	0.050	0.070	0.050
5	100950	LOCKING RING 12MM RF114	1.000	1.000	1.000	1.000
6	104209	CLEVIS PIN 3/16"X 1 1/32"		1.000		1.000
	104210	CLEVIS PIN 3/16" X 25/32"	1.000		1.000	

**Dive Strut Assembly A4-4978**

ASSEMBLY MATERIAL PART LIST						
DESCRIPTION	ASSM P/NO.	SPROG TUBE	SPROG WIRE	CLEAVIS PIN	DIM X	DIM Y
CLIMAX 13 OUTBOARD DIVE STRUT	#104487	#104295	#104263	3/16" x 1 1/32"	50mm	dia.25x125
CLIMAX 13 INBOARD DIVE STRUT	#104485	#104296	#104262	3/16" x 25/32"	70mm	dia.25x175
CLIMAX 14 OUTBOARD DIVE STRUT	#104488	#104297	#104261	3/16" x 1 1/32"	50mm	dia.25x180
CLIMAX 14 INBOARD DIVE STRUT	#104486	#104298	#104260	3/16" x 25/32"	70mm	dia.25x160

ID	DESCRIPTION	DWG	PART NO.	REQD
1	SPROG TUBE		LIST	
2	SPROG WIRE		LIST	
3	HEAT SHRINK CLEAR 25		104416	
4	EDGE MOULDING		100561	
5	LOCKING RING 12mm RF114		100950	
6	CLEVIS PIN 3/16 x 1 1/32"		104209	
6	CLEVIS PIN 3/16 x 25/32"		104210	

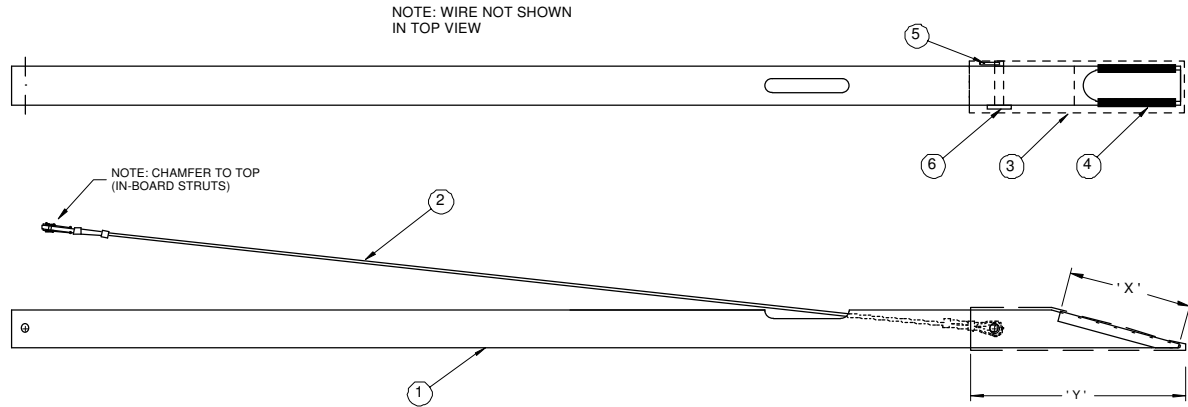

Rev	AMENDMENTS	Date
1	SPROG WIRE PART# UPDATE	18/09/01
2	HS LENGTHS CHANGED, NOTE ADDED	15/11/01

ALL DIMENSIONS IN MILLIMETRES  
UNLESS STATED OTHERWISE

Drawn By	Scale	Date
CRIS	NTS	28/05/01

AIRBORNE WINDSPORTS <small>PTY LTD</small>	
DIVE STRUT ASSEMBLY	A4-4978