

Manual Change

Agilent Part No. N/A

Apr 2009

Change 1

Change the Measurement Uncertainty value of Frequency Accuracy Test (Page 51) to the following.

Frequency	Test Limits	Test Result ¹	Measurement Uncertainty
120 Hz	±1.2Hz	Hz	± 0.024Hz
1kHz	±0.50Hz	Hz	± 0.20Hz

Change 2

Change the Measurement Uncertainty value of Signal Level Accuracy Test (Page 51) to the following.

Frequency	Signal Level	Test Limits	Test Result ¹	Measurement Uncertainty
120 Hz	1000mV	±100mV	V	± 0.11mV
120 Hz	500mV	±50mV	V	± 0.066mV
120 Hz	100mV	±10mV	V	± 0.011mV
1kHz	1000mV	±100mV	V	± 0.11mV
1kHz	500mV	±50mV	V	± 0.066mV
1kHz	100mV	±10mV	V	± 0.011mV

Change 3

Change the Measurement Uncertainty value of Measurement Accuracy Test (Page 52-55) to the following.

Measurement Accuracy Test (0 m, 1000 pF, Meas. Time: MED, ALC: OFF)

Frequency	Signal Level	Parameter Measured	Test Limits	Test Result	Measurement Uncertainty
1 kHz	1000 mV	Cp	± 1.9 pF	pF	± 0.19 pF
1 kHz	1000 mV	D	± 0.0019		± 0.00002

Measurement Accuracy Test (0 m, 0.01 µF, Meas. Time: MED, ALC: OFF)

Frequency	Signal Level	Parameter Measured	Test Limits	Test Result	Measurement Uncertainty
120 Hz	1000 mV	Cp	± 0.019 nF	nF	± 0.0021 nF
120 Hz	1000 mV	D	± 0.0019		± 0.00002
1 kHz	1000 mV	Cp	± 0.018 nF	nF	± 0.0021 nF
1 kHz	1000 mV	D	± 0.0018		± 0.00002

Measurement Accuracy Test (0 m, 0.1 µF, Meas. Time: MED, ALC: OFF)

Frequency	Signal Level	Parameter Measured	Test Limits	Test Result	Measurement Uncertainty
120 Hz	1000 mV	Cp	± 0.18 nF	nF	± 0.021 nF
120 Hz	1000 mV	D	± 0.0018		± 0.00003
1 kHz	1000 mV	Cp	± 0.18 nF	nF	± 0.021 nF
1 kHz	1000 mV	D	± 0.0018		± 0.00002

Measurement Accuracy Test (0 m, 1 μ F, ALC: OFF)

Frequency	Signal Level	Meas. Time	Parameter Measured	Test Limits	Test Result	Meas. Uncertainty
120 Hz	1000 mV	MED	Cp	$\pm 0.0020 \mu\text{F}$	μF	$\pm 0.00021 \mu\text{F}$
120 Hz	1000 mV	MED	D	± 0.0020		± 0.00004
1 kHz	1000 mV	MED	Cp	$\pm 0.0018 \mu\text{F}$	μF	$\pm 0.00021 \mu\text{F}$
1 kHz	1000 mV	MED	D	± 0.0018		± 0.00002
120 Hz	500 mV	MED	Cp	$\pm 0.0020 \mu\text{F}$	μF	$\pm 0.00021 \mu\text{F}$
120 Hz	500 mV	MED	D	± 0.0020		± 0.00004
1 kHz	500 mV	MED	Cp	$\pm 0.0018 \mu\text{F}$	μF	$\pm 0.00021 \mu\text{F}$
1 kHz	500 mV	MED	D	± 0.0018		± 0.00002
120 Hz	300 mV	MED	Cp	$\pm 0.0020 \mu\text{F}$	μF	$\pm 0.00021 \mu\text{F}$
120 Hz	300 mV	MED	D	± 0.0020		± 0.00004
1 kHz	300 mV	MED	Cp	$\pm 0.0018 \mu\text{F}$	μF	$\pm 0.00021 \mu\text{F}$
1 kHz	300 mV	MED	D	± 0.0018		± 0.00002
120 Hz	100 mV	MED	Cp	$\pm 0.0027 \mu\text{F}$	μF	$\pm 0.00021 \mu\text{F}$
120 Hz	100 mV	MED	D	± 0.0027		± 0.00004
1 kHz	100 mV	MED	Cp	$\pm 0.0025 \mu\text{F}$	μF	$\pm 0.00021 \mu\text{F}$
1 kHz	100 mV	MED	D	± 0.0025		± 0.00002
120 Hz	1000 mV	LONG	Cp	$\pm 0.0020 \mu\text{F}$	μF	$\pm 0.00021 \mu\text{F}$
120 Hz	1000 mV	LONG	D	± 0.0020		± 0.00004
1 kHz	1000 mV	LONG	Cp	$\pm 0.0018 \mu\text{F}$	μF	$\pm 0.00021 \mu\text{F}$
1 kHz	1000 mV	LONG	D	± 0.0018		± 0.00002
120 Hz	1000 mV	SHORT	Cp	$\pm 0.0036 \mu\text{F}$	μF	$\pm 0.00021 \mu\text{F}$
120 Hz	1000 mV	SHORT	D	± 0.0036		± 0.00004
1 kHz	1000 mV	SHORT	Cp	$\pm 0.0022 \mu\text{F}$	μF	$\pm 0.00021 \mu\text{F}$
1 kHz	1000 mV	SHORT	D	± 0.0022		± 0.00002

Measurement Accuracy Test (0 m, 1 μ F, Meas. Time: MED, ALC: OFF, Sync. Source Function: ON)

Frequency	Signal Level	Parameter Measured	Test Limits	Test Result	Measurement Uncertainty
120 Hz	1000 mV	Cp	$\pm 0.0020 \mu\text{F}$	μF	$\pm 0.00021 \mu\text{F}$
120 Hz	1000 mV	D	± 0.0020		± 0.00004
1 kHz	1000 mV	Cp	$\pm 0.0018 \mu\text{F}$	μF	$\pm 0.00021 \mu\text{F}$
1 kHz	1000 mV	D	± 0.0018		± 0.00002

Measurement Accuracy Test (0 m, 100 Ω , Meas. Time: MED, ALC: OFF)

Frequency	Signal Level	Parameter Measured	Test Limits	Test Result	Measurement Uncertainty
120 Hz	1000 mV	Rs	$\pm 0.20 \Omega$	Ω	$\pm 0.006 \Omega$

Measurement Accuracy Test (0 m, 10 Ω , Meas. Time: MED, ALC: OFF)

Frequency	Signal Level	Parameter Measured	Test Limits	Test Result	Measurement Uncertainty
120 Hz	1000 mV	Rs	$\pm 0.044 \Omega$	Ω	$\pm 0.0006 \Omega$
1 kHz	1000 mV	Rs	$\pm 0.018 \Omega$	Ω	$\pm 0.0006 \Omega$

Measurement Accuracy Test (0 m, 1 Ω , Meas. Time: MED, ALC: OFF)

Frequency	Signal Level	Parameter Measured	Test Limits	Test Result	Measurement Uncertainty
120 Hz	500 mV	Rs	$\pm 0.0097 \Omega$	Ω	$\pm 0.0001 \Omega$
1 kHz	500 mV	Rs	$\pm 0.0057 \Omega$	Ω	$\pm 0.0001 \Omega$

Measurement Accuracy Test (0 m, 1 Ω , Meas. Time: MED, ALC: ON)

Frequency	Signal Level	Parameter Measured	Test Limits	Test Result	Measurement Uncertainty
120 Hz	500 mV	Rs	$\pm 0.0097 \Omega$	Ω	$\pm 0.0001 \Omega$
1 kHz	500 mV	Rs	$\pm 0.0057 \Omega$	Ω	$\pm 0.0001 \Omega$

Measurement Accuracy Test (1 m, 1 μ F, Meas. Time: MED, ALC: OFF)

Frequency	Signal Level	Parameter Measured	Test Limits	Test Result	Measurement Uncertainty
120 Hz	1000 mV	Cp	$\pm 0.0020 \mu$ F	μ F	$\pm 0.00021 \mu$ F
120 Hz	1000 mV	D	± 0.0020		± 0.00015
1 kHz	1000 mV	Cp	$\pm 0.0018 \mu$ F	μ F	$\pm 0.00021 \mu$ F
1 kHz	1000 mV	D	± 0.0018		± 0.00010

Measurement Accuracy Test (1 m, 10 μ F, Meas. Time: MED, ALC: OFF)

Frequency	Signal Level	Parameter Measured	Test Limits	Test Result	Measurement Uncertainty
120 Hz	1000 mV	Cp	$\pm 0.0197 \mu$ F	μ F	$\pm 0.0021 \mu$ F
120 Hz	1000 mV	D	± 0.00197		± 0.00004
1 kHz	1000 mV	Cp	$\pm 0.018 \mu$ F	μ F	$\pm 0.0021 \mu$ F
1 kHz	1000 mV	D	± 0.0018		± 0.00004

Measurement Accuracy Test (2 m, 1 μ F, Meas. Time: MED, ALC: OFF)

Frequency	Signal Level	Parameter Measured	Test Limits	Test Result	Measurement Uncertainty
120 Hz	1000 mV	Cp	$\pm 0.0020 \mu$ F	μ F	$\pm 0.00021 \mu$ F
120 Hz	1000 mV	D	± 0.0020		± 0.00015
1 kHz	1000 mV	Cp	$\pm 0.0018 \mu$ F	μ F	$\pm 0.00021 \mu$ F
1 kHz	1000 mV	D	± 0.0018		± 0.00010

Agilent 4268A 120Hz/1kHz Capacitance Meter

Service Manual

Fourth Edition



Agilent Part No. 04268-90110

May 2003

Printed in Japan

Notices

The information contained in this document is subject to change without notice.

This document contains proprietary information that is protected by copyright. All rights are reserved. No part of this document may be photocopied, reproduced, or translated to another language without the prior written consent of the Agilent Technologies.

Agilent Technologies Japan, Ltd.

Component Test PGU-Kobe

1-3-2, Murotani, Nishi-Ku, Kobe-shi, Hyogo, 651-2241 Japan

© Copyright 1999, 2000, 2003 Agilent Technologies Japan, Ltd.

Manual Printing History

The manual's printing date and part number indicate its current edition. The printing date changes when a new edition is printed. (Minor corrections and updates that are incorporated at reprint do not cause the date to change.) The manual part number changes when extensive technical changes are incorporated.

April 1999	First Edition
November 1999	Second Edition
June 2000	Third Edition
May 2003	Fourth Edition

Safety Summary

The following general safety precautions must be observed during all phases of operation, service, and repair of this instrument. Failure to comply with these precautions or with specific WARNINGS elsewhere in this manual may impair the protection provided by the equipment. In addition it violates safety standards of design, manufacture, and intended use of the instrument.

The Agilent Technologies assumes no liability for the customer's failure to comply with these requirements.

NOTE

4268A comply with INSTALLATION CATEGORY II and POLLUTION DEGREE 2 in IEC1010-1. 4268A are INDOOR USE product.

NOTE

LEDs in 4268A are Class 1 in accordance with IEC825-1.
CLASS 1 LED PRODUCT

- Ground The Instrument

To avoid electric shock hazard, the instrument chassis and cabinet must be connected to a safety earth ground by the supplied power cable with earth blade.

- DO NOT Operate In An Explosive Atmosphere

Do not operate the instrument in the presence of flammable gasses or fumes. Operation of any electrical instrument in such an environment constitutes a definite safety hazard.

- Keep Away From Live Circuits

Operating personnel must not remove instrument covers. Component replacement and internal adjustments must be made by qualified maintenance personnel. Do not replace components with the power cable connected. Under certain conditions, dangerous voltages may exist even with the power cable removed. To avoid injuries, always disconnect power and discharge circuits before touching them.

- DO NOT Service Or Adjust Alone

Do not attempt internal service or adjustment unless another person, capable of rendering first aid and resuscitation, is present.

- DO NOT Substitute Parts Or Modify Instrument

Because of the danger of introducing additional hazards, do not install substitute parts or perform unauthorized modifications to the instrument. Return the instrument to a Agilent Technologies Sales and Service Office for service and repair to ensure that safety features are maintained.

- Dangerous Procedure Warnings

Warnings, such as the example below, precede potentially dangerous procedures throughout this manual. Instructions contained in the warnings must be followed.

WARNING

Dangerous voltages, capable of causing death, are presenting this instrument. Use extreme caution when handling, testing, and adjusting this instrument.

Warranty

This Agilent Technologies instrument product is warranted against defects in material and workmanship for a period corresponding to the individual warranty periods of its component products. Instruments are warranted for a period of one

year. Fixtures and adapters are warranted for a period of 90 days. During the warranty period, Agilent Technologies will, at its option, either repair or replace products that prove to be defective.

For warranty service or repair, this product must be returned to a service facility designated by Agilent Technologies. Buyer shall prepay shipping charges to Agilent Technologies and Agilent Technologies shall pay shipping charges to return the product to Buyer. However, Buyer shall pay all shipping charges, duties, and taxes for products returned to Agilent Technologies from another country.

Agilent Technologies warrants that its software and firmware designated by Agilent Technologies for use with an instrument will execute its programming instruction when properly installed on that instrument. Agilent Technologies does not warrant that the operation of the instrument, or software, or firmware will be uninterrupted or error free.

Certification

Agilent Technologies certifies that this product met its published specifications at the time of shipment from the factory. Agilent Technologies further certifies that its calibration measurements are traceable to the United States National Institute of Standards and Technology, to the extent allowed by the Institution's calibration facility, or to the calibration facilities of other International Standards Organization members.

Limitation Of Warranty

The foregoing warranty shall not apply to defects resulting from improper or inadequate maintenance by Buyer, Buyer-supplied software or interfacing, unauthorized modification or misuse, operation outside the environmental specifications for the product, or improper site preparation or maintenance.

IMPORTANT

No other warranty is expressed or implied. Agilent Technologies specifically disclaims the implied warranties of merchantability and fitness for a particular purpose.

Assistance

Product maintenance agreements and other customer assistance agreements are available for Agilent Technologies products.









For any assistance, contact your nearest Agilent Technologies Sales and Service Office. Addresses are provided at the back of this manual.

Exclusive Remedies

The remedies provided herein are buyer's sole and exclusive remedies. Agilent Technologies shall not be liable for any direct, indirect, special, incidental, or consequential damages, whether based on contract, tort, or any other legal theory.

Safety Symbol

General definitions of safety symbols used on the instrument or in manuals are listed below.

-  Instruction Manual symbol: the product is marked with this symbol when it is necessary for the user to refer to the instrument manual.
-  Alternating current.
-  Direct current.
-  On (Supply).
-  Off (Supply).
-  In position of push-button switch.
-  Out position of push-button switch.
-  Frame (or chassis) terminal. A connection to the frame (chassis) of the equipment which normally include all exposed metal structure.

WARNING

This warning sign denotes a hazard. It calls attention to a procedure, practice, condition or the like, which, if not correctly performed or adhered to, could result in injury or death to personnel.

CAUTION

This Caution sign denotes a hazard. It calls attention to a procedure, practice, condition or the like, which, if not correctly performed or adhered to, could result in damage to or destruction of part or all of the product.

NOTE

Note denotes important information. It calls attention to a procedure, practice, condition or the like, which is essential to highlight.

Contents

1. General Information	
Instruments Covered by This Manual	10
Required Equipment	11
2. Maintenance	
Test Equipment	14
How to set the 4268A for the Maintenance	15
Resetting the 4268A	15
Measurement Parameter Settings	15
Frequency Setting	16
Signal Level Setting	16
Cable Length Setting	16
Measurement Time Mode Setting	16
Trigger Mode Setting	17
ALC Setting	17
Performance Test	18
Introduction	18
Frequency Accuracy Test	19
Signal Level Accuracy Test	21
Measurement Accuracy Test	23
Function Test	30
Introduction	30
Signal Level Monitor Test	31
ALC Function Test	33
Contact Check Test	35
Handler Interface Test	37
Scanner Interface Test (opt. 001 only)	41
Calculation Sheet	44
Performance Test	44
Function Test	50
Test Record	51
Performance Test Record	51
Function Test Record	56
3. Adjustment	
Required Controller	58
Windows PC(Personal Computer)	58
Required Equipment	58
Adjustment Program	58
Program Installation	60
Running the Adjustment Program	60
Adjustment Procedure Reference	61
Signal Level Adjustment	61
Signal Level Monitor Adjustment	63
Impedance Measurement Adjustment	64
4. Troubleshooting	
Introduction	68

Contents

Safety	68
ESD Precautions	68
Required Equipment	68
Trouble Isolation	69
Overall Troubleshooting	69
Power Supply Troubleshooting	70
Digital Circuit Troubleshooting	73
Analog Circuit Troubleshooting	75
Service Function	77
Firmware Revision Confirmation	77
Self Test	78
Power On Self-test	79
Front Panel Key Test	80
Handler Interface Test	80
Scanner Interface Test (Opt. 001 only)	80
ROM Test	81
RAM Test	81
EEPROM Test	82
Adjustment Data Setting	83
Theory of Operation	84
Overall Measurement Theory	84
Analog Circuit	84
Digital Circuit	88
Power Supply Circuit	89
5. Assembly Replacement	
Safety	92
ESD Precautions	92
Replaceable Parts List	92
Ordering Information	92
Exchange Assemblies	92
Parts List	94
Disassembly Procedure	107
Cover Removal	107
A1 Main Board Removal	107
A2 CPU Board Replacement	109
Power Supply Assembly Removal	111
Fan Assembly Removal	112
Front Assembly Removal	112
LCD Assembly Removal	112
Keyboard Assembly Removal	113
BNC Connector Removal	113
EEPROM or Boot ROM Replacement	113
Post Replacement Procedure	114
Firmware Installation	115
Required Controller	115
Installation Program and Firmware File	115
Firmware installation Procedure	115

1 General Information

The Service Manual is a guide to servicing the 4268A 120 Hz/1 kHz Capacitance Meter. The manual contains information requisite to do performance test, adjust, troubleshoot, and repair.

Instruments Covered by This Manual

Agilent Technologies uses a two-part, ten-character serial number label (See Figure) attached to the instrument's rear panel. The first five characters are the serial prefix and the last five digits are the suffix.

Figure 1-1 Serial Number Label Example



An instrument manufactured after the printing date of this manual may have serial number prefix that is not listed on the title page. This unlisted serial number prefix indicates the instrument is different from those described in this manual. The manual for this new instrument may be accompanied by a yellow Manual Changes supplement or have a different manual part number. This sheet contains “change information” that explains how to adapt the manual to the newer instrument.

In addition to change information, the supplement may contain information for correcting errors (Errata) in the manual. To keep this manual as current and accurate as possible, Agilent Technologies recommends that you periodically request the latest Manual Changes supplement. The supplement for this manual is identified by this manual's printing data and is available from Agilent Technologies. If the serial prefix or number of an instrument is lower than that on the title page of this manual, see Appendix A, Manual Changes. For information concerning a serial number prefix that is not listed on the title page or in the Manual change supplement, contact the nearest Agilent Technologies office.

Required Equipment

Table 1-1 lists the recommended equipment for performing maintenance on the 4268A.

Table 1-1 Recommended Test Equipment

Equipment	Critical specifications	Recommended Model	Qty.	Use ^a
Frequency Counter	Frequency: 120 Hz to 100 kHz Accuracy: < 0.01 %	3458A	1	P
Voltmeter	Frequency: DC to 1 kHz Voltage Range: 100 mV _{rms} to 1 V _{rms} Accuracy: < 0.5 %	3458A	1	P,A,T
Standard Resistor Set	No Substitute	42030A	1	P,F,A
Standard Capacitor Set	No Substitute	16380A	1	P
Standard Capacitor Set	No Substitute	16380C Opt.001	1	P
OPEN Termination	No Substitute	42090A	1	P,F,A
SHORT Termination	No Substitute	42091A	1	P,A
1 m Test Leads	No Substitute	16048A	1	P,F,A
2 m Test Leads	No Substitute	16048D	1	P,A
Adaptor	BNC(f)-BNC(f)	p/n 1250-0080	4	P,F,A
Adaptor	Dual Banana-BNC(f)	p/n 1251-2277	1	P,F,A,T
Cable	61 cm BNC(m)-BNC(m)	p/n 8120-1839	1	P,F,A,T
Interface Box	No substitute	p/n 04284-65007	1	F,A
Handler Interface Simulator	No Substitute	p/n 04278-65001	1	F
Scanner Interface Simulator	No Substitute	p/n 04278-65301	1	F

a. P: Performance Tests, F: Function Tests, A: Adjustment, T: Troubleshooting

General Information
Required Equipment

2 Maintenance

This chapter provides information on how to maintain the 4268A. The maintenance consists of performance test and function test.

Test Equipment

The required test equipment is listed on Table 1-1 on page 11. Use only calibrated equipment when adjusting the 4268A.

How to set the 4268A for the Maintenance

This section shows the 4268A measurement condition setting procedures, which are used in the performance test and the function test.

Resetting the 4268A.

Step 1. Press the **Reset** key (blue key, . key). The menu below appears.

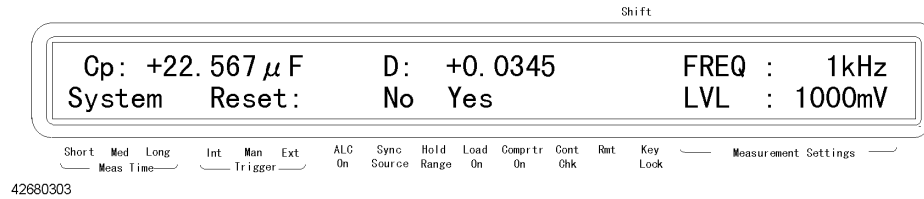

Step 2. Press the $\uparrow \rightarrow$ key to blink Yes, and then press the **Enter** key.

Measurement Parameter Settings

Step 1. Press the **Meas Prmtr** key. The primary parameter selection menu below appears.

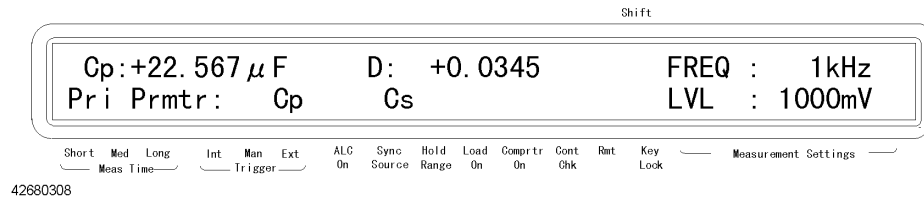

Step 2. The blinking parameter is the current setting of the primary parameter. To change the setting, use the $\uparrow \rightarrow$ key to blink the parameter you want to set and then press the **Enter** key.

Step 3. The secondary parameter selection menu below appears. In the same way as the primary parameter, use the $\uparrow \rightarrow$ key to blink the parameter you want to set and then press the **Enter** key. (The secondary parameters displayed in the menu vary depending on the selected primary parameter. The following example shows the display when Cp is selected.)

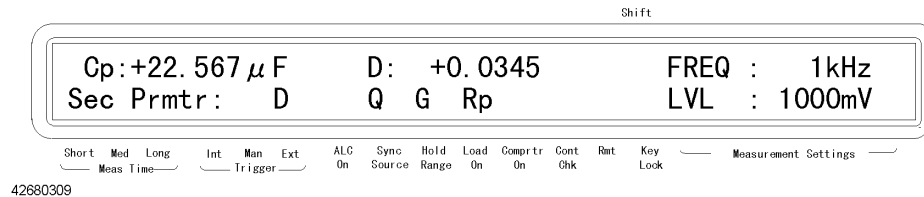

Frequency Setting

Step 1. Press the **Freq** key. The menu as shown below appears.

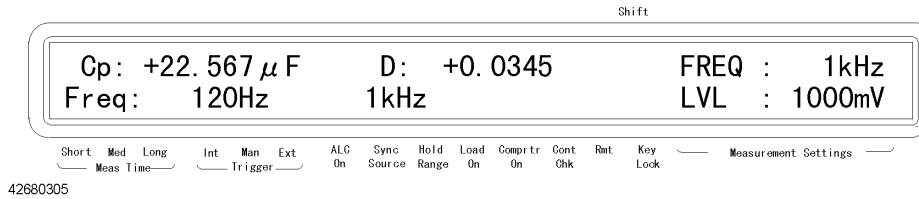

Step 2. The blinking frequency is the current setting. To change the setting, press the $\uparrow\rightarrow$ key or press the **Freq** key again to blink the measurement frequency (120 Hz or 1 kHz) you want to set, and press the **Enter** key.

Signal Level Setting

Step 1. Press the **Level** key. The menu as shown below appears.

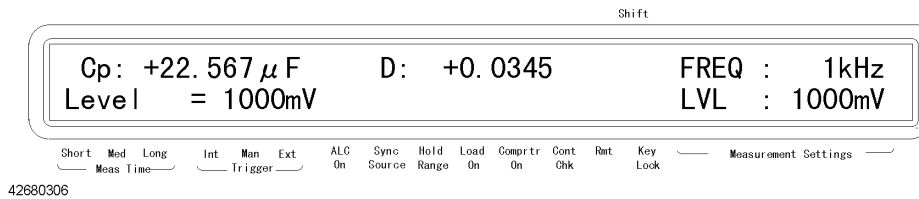

Step 2. Using numeric keys and other necessary keys, enter a desired level, and press the **Enter** key. For example, press **5, 0, 0, Eng,** and **Enter** keys to set the signal level to 500 mV.

Cable Length Setting

Step 1. Press the **Cable** key (blue key, **3** key). The menu below appears.

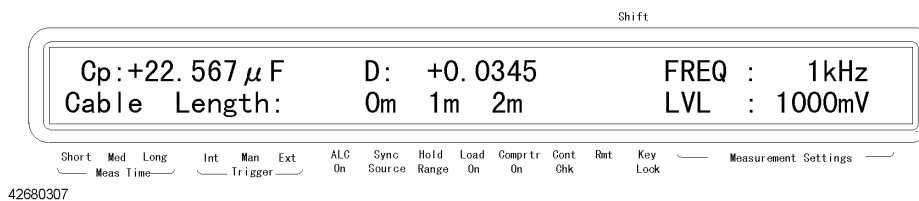

Step 2. The blinking value is the current setting of the cable length. To change the setting, use the $\uparrow\rightarrow$ key or $\leftarrow\downarrow$ key to blink the cable length you want to use and then press the **Enter** key.

Measurement Time Mode Setting

Press the Meas Time key. The \blacktriangledown symbol above either Short, Med, or Long indicates the current measurement time setting. The following figure is an example when Med is selected.

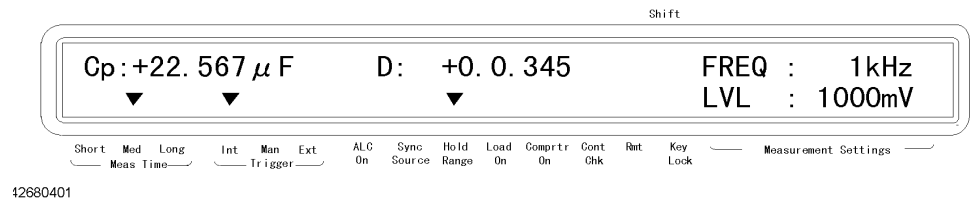

Trigger Mode Setting

Press the Trig Mode key. The ▼ symbol above either Int, Man, Ext indicates the current trigger mode setting. The figure above is an example when internal trigger mode is selected.

ALC Setting

Press the ALC key. Each press toggles ON/OFF. If the ▼ symbol above ALC On is displayed, the function is on.

Performance Test

Introduction

This section provides the test procedures used to verify that the 4268A's specifications are met. The performance tests can also be used for incoming inspection, and for verification after troubleshooting or adjustment. If the performance tests indicate that the 4268A is *NOT* operating within the specified limits, check your test setup, then proceed with troubleshooting if necessary.

Warm Up Time

Allow the 4268A to warm up for at least 30 minutes before you execute any of the performance tests

Ambient Conditions

Perform all performance tests in ambient conditions of $23\text{ }^{\circ}\text{C} \pm 5\text{ }^{\circ}\text{C}$, $\leq 70\%$ RH.

Performance Test Interval

The performance test should be performed periodically. The recommended test interval is 12 months.

NOTE

The test interval depends on maintenance of use and the environmental conditions under which the instrument is used. You may find that the test interval could be shortened or lengthened; however, such a decision should be based on substantial quantitative data.

Performance Test Record and Calculation Sheet

Performance test record lists all test points, acceptable test limits, test result entry columns, and measurement uncertainties. The listed measurement uncertainties are valid only when the recommended test equipment is used.

The calculation sheet is used as an aid for recording raw measurement data, and for calculating the performance test results.

The procedure for using the calculation sheet and performance test record is;

1. Photo copy the calculation sheet.
2. Follow the performance test procedure and record the measurement values, the 4268A's reading, etc., into the specified column on the calculation sheet.
3. Calculate the test result using the appropriate equation given on the calculation sheet, and record the test result into the Test Result column of the performance test record.

Frequency Accuracy Test

The 4268A's frequency is measured with a frequency counter.

Specification

Frequency Accuracy: $\pm 0.05\%$ at 1 kHz
 $\pm 1\%$ at 120 Hz

Test Equipment

Description	Recommended Model
Frequency Counter	3458A
61 cm BNC(m)-BNC(m) Cable	p/n 8120-1839
Dual Banana-BNC(f) Adapter	p/n 1251-2277

Procedure

1. Reset the 4268A.
2. Set up the equipment as shown in Figure 2-1.

Figure 2-1 Frequency Accuracy Test Setup

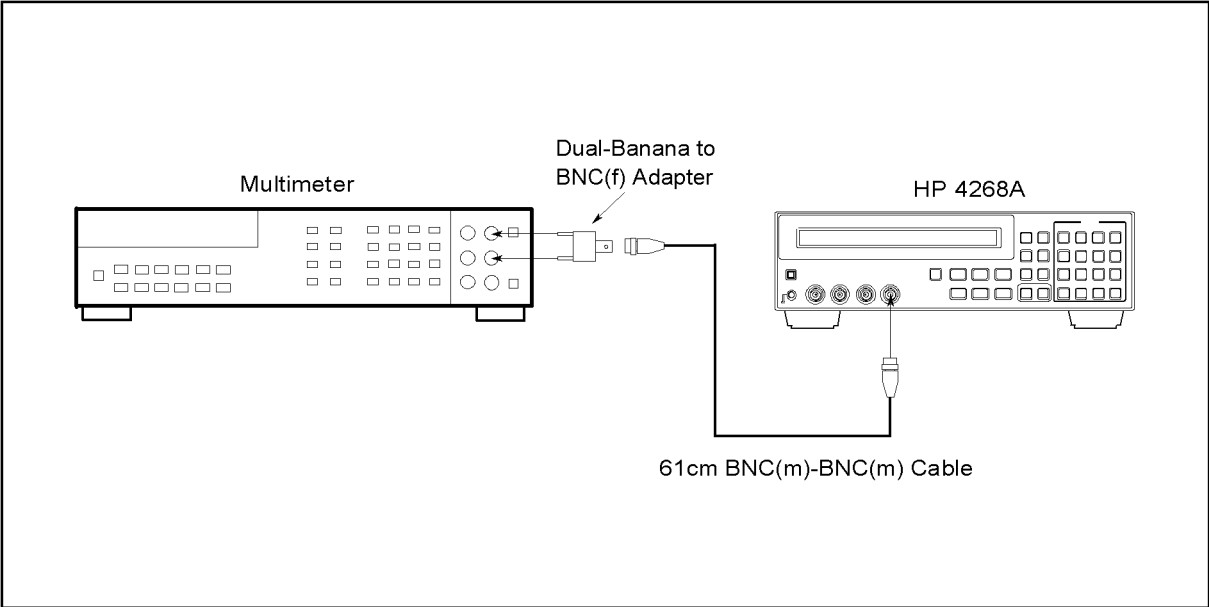

4268ASE02001

Maintenance
Performance Test

3. Set the 3458A Multimeter to the frequency measurement mode pressing the **FREQ** key on the front panel of the 3458A.
4. Select the 4268A's frequency to 120 Hz.
5. Record the multimeter reading on the calculation sheet.
6. Calculate the result according to the calculation sheet, and record the result into the performance test record.
7. Change the 4268A's frequency to 1 kHz, and perform Step 5 and 6.

Signal Level Accuracy Test

The 4268A's signal level is measured with an AC voltmeter.

Specification

Signal Level Accuracy: $\pm 10\%$

Test Equipment

Description	Recommended Model
AC Voltmeter	3458A
61 cm BNC(m)-BNC(m) Cable	p/n 8120-1839
Dual Banana-BNC(f) Adapter	p/n 1251-2277

Procedure

1. Reset the 4268A.
2. Set up the equipment as shown in Figure 2-2.

Figure 2-2 Signal Level Accuracy Test Setup

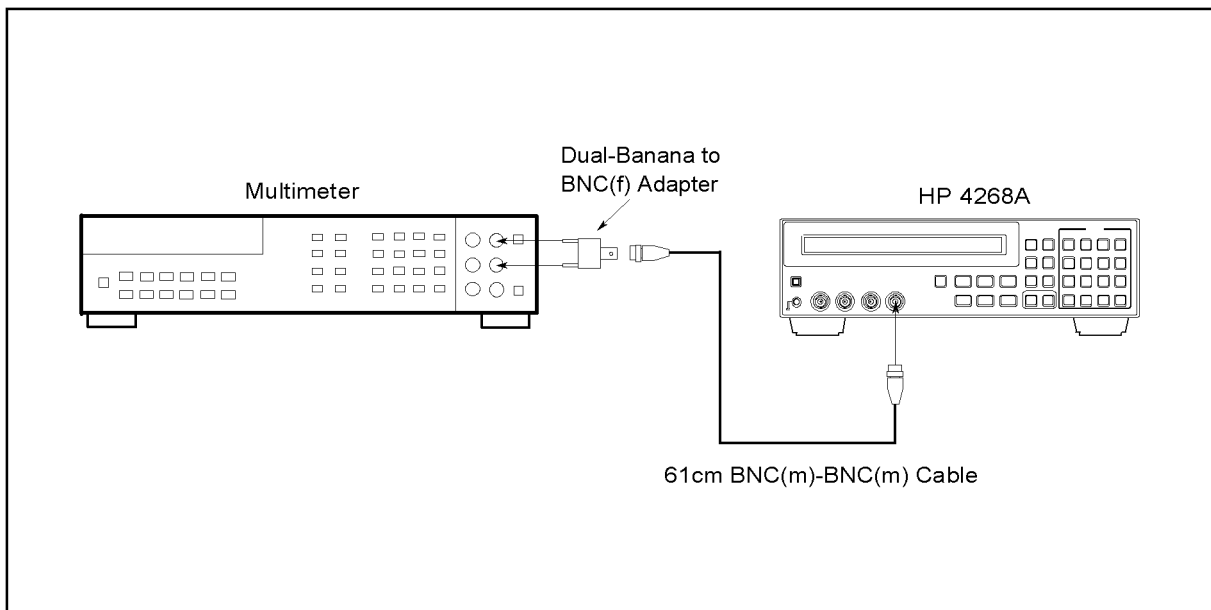

4268ASE02001

3. Set the 3458A Multimeter to the Synchronously Sub-sample AC voltage measurement mode using the following procedure:
 - a. Press the **ACV** key to set the measurement mode to AC voltage.
 - b. Press the **S** key (blue key, **N Rdgs/Trig** key), \downarrow , \downarrow , \downarrow to display SETACV.

Maintenance
Performance Test

- c. Press →, ↓, ↓, ↓, to display SYNC, then press **Enter**.
4. Set the 4268A's signal level to 1000 mV.
5. Set the test 4268A's signal frequency to 120 Hz.
6. Record the Multimeter reading on the calculation sheet.
7. Calculate the test result according to the calculation sheet, and record the result into the performance test record.
8. Change the signal settings to perform this test for all settings listed in Table 2-1.

Table 2-1 **Signal Level Accuracy Test Settings**

Frequency	Signal Level
120 Hz	1000 mV
	500 mV
	100 mV
1 kHz	1000 mV
	500 mV
	100 mV

Measurement Accuracy Test

The 4268A measures the calibrated standard capacitors and resistors at the 4268A's front panel, and the measured values are compared with the standards' listed calibration values.

Specification

Basic Measurement Accuracy: $\pm 0.2\%$ (See Chapter 10 on the 4268A Operation Manual for details.)

Test Equipment

Description	Recommended Model
Standard Capacitor Set	16380A
Standard Capacitor Set	16380C Opt.001
Standard Resistor Set	42030A
Test Leads, 1m	16048A
Test Leads, 2m	16048D
OPEN Termination	42090A
SHORT Termination	42091A
Adapter BNC(f)-BNC(f)	p/n 1250-0080, 4ea

Procedure

Measurement Accuracy Test (0m, Capacitance, Sync. Source Function : ON)

1. Record the 16380A, 16380C, and 42030A calibration values on the calculation sheet.
2. Reset the 4268A.
3. Connect the OPEN termination to the 4268A's UNKNOWN terminal.

Figure 2-3 Measurement Accuracy Test(0m) Setup

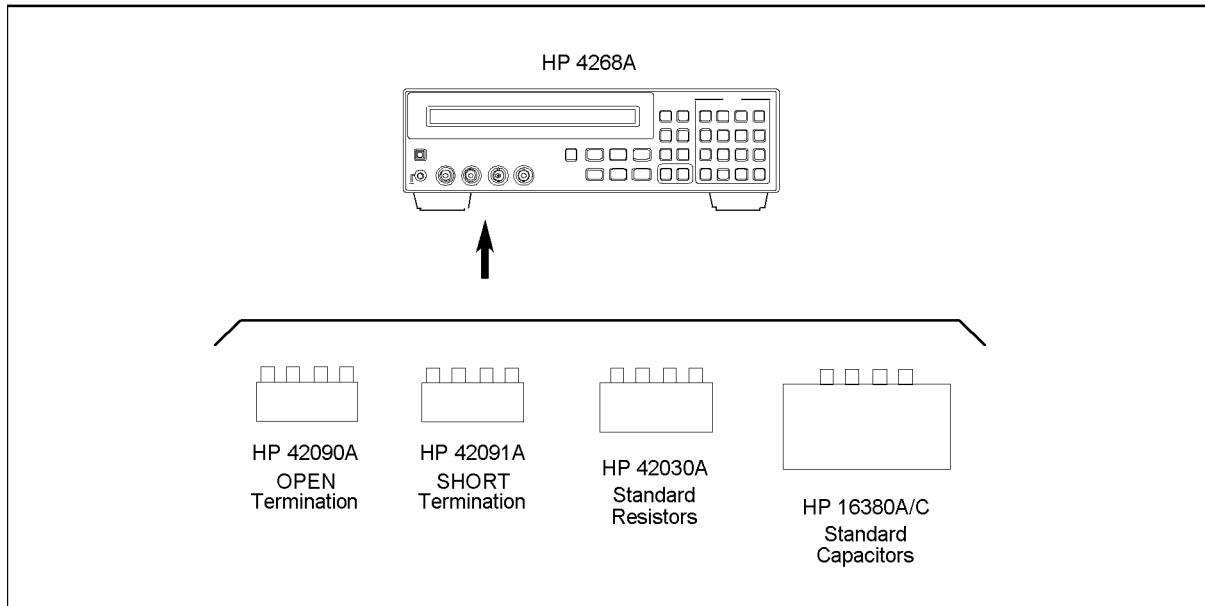

4268ASE02002

4. Press the **Open** key (blue key, **4** key) to display the OPEN correction menu.
5. Select OpenMeas using $\leftarrow\downarrow$ or $\uparrow\rightarrow$ key, and press **Enter**. The OPEN correction is performed.
6. Connect the SHORT termination to the 4268A's UNKNOWN terminals.
7. Press the **Short** key (blue key, **5** key) to display the SHORT correction menu.
8. Select ShortMeas using $\leftarrow\downarrow$ or $\uparrow\rightarrow$ key, and press **Enter**. The SHORT correction is performed.
9. Set the 4268A trigger mode to manual.
10. Connect the 1000 pF Standard Capacitor to the 4268A's UNKNOWN terminals.
11. Press the **Trig** key to start the measurement.
12. Record the 4268A readings of Cp and D on the calculation sheet.
13. Calculate the test results according to the calculation sheet, and record the results into the performance test record.

14. Perform this test for all standards and frequency settings listed in Table 2-2

Table 2-2 Measurement Accuracy Test(0m, Capacitance) settings

Standard	Meas. Time	Signal Level	Frequency
1000 pF	MED	1000 mV	1kHz
0.01 μ F	MED	1000 mV	120 Hz
			1 kHz
0.1 μ F	MED	1000 mV	120 Hz
			1 kHz
1 μ F	MED	1000 mV	120 Hz
			1 kHz
		500 mV	120 Hz
			1 kHz
		300 mV	120 Hz
			1 kHz
		100 mV	120 Hz
			1 kHz
	LONG	1000 mV	120 Hz
			1 kHz
SHORT	1000 mV	120 Hz	
		1 kHz	

Measurement Accuracy Test(0m, Capacitance, Sync. Source Function : ON)

15. Set the 4268A's measurement time mode to MED.
16. Set the 4268A's frequency to 120 Hz.
17. Activate the Synchronous source function using the following procedure.
 - a. Press the **Sync Source** key (blue key, **Level** key)
 - b. Check the instrument setting indicator at the bottom of the display. the ▼ symbol is displayed above "Sync Source".
18. Confirm that the 1 μ F Standard is connected to the 4268A's UNKNOWN terminals.
19. Press the **Trig** key to start the measurement.
20. Record the 4268A readings of Cp and D on the calculation sheet.
21. Calculate the test results according to the calculation sheet, and record the

Maintenance
Performance Test

results into the performance test record.

22. Set the Frequency to 1 kHz, and perform step 19 to 21.

Measurement Accuracy Test(0m, Resistance)

23. Set the Synchronous source function to OFF using the following procedure.

- a. Press the **Sync Source** key (blue key, **Level** key)
- b. Check the instrument setting indicator at the bottom of the display. NOTHING is displayed above “Sync Source”.

24. Set the 4268A’s measurement parameter to Cs-Rs.

25. Connect the 100 Ω Standard Resistor to the 4268A’s UNKNOWN terminals.

26. Press the **Trig** key to start the measurement.

27. Record the 4268A readings of Rs on the calculation sheet.

28. Calculate the test result according to the calculation sheet, and record the result into the performance test record.

29. Perform this test for all standards and frequency settings listed in Table 2-3

Table 2-3 Measurement Accuracy Test(0m, Resistance) settings

Standard	Signal Level	ALC	Frequency
100 Ω	1000 mV	OFF	120 Hz
10 Ω	1000 mV	OFF	120 Hz
			1 kHz
1 Ω	500 mV	OFF	120 Hz
			1 kHz
		ON	120 Hz
			1 kHz

Measurement Accuracy Test (1m)

30. Reset the 4268A.

31. Set the cable length to 1m.

32. Connect the OPEN termination to the 4268A’s UNKNOWN terminals using the 1m test leads and four BNC(f)-BNC(f) adapters as shown in Figure 2-4.

Figure 2-4 Measurement Accuracy Test(1 m) Setup

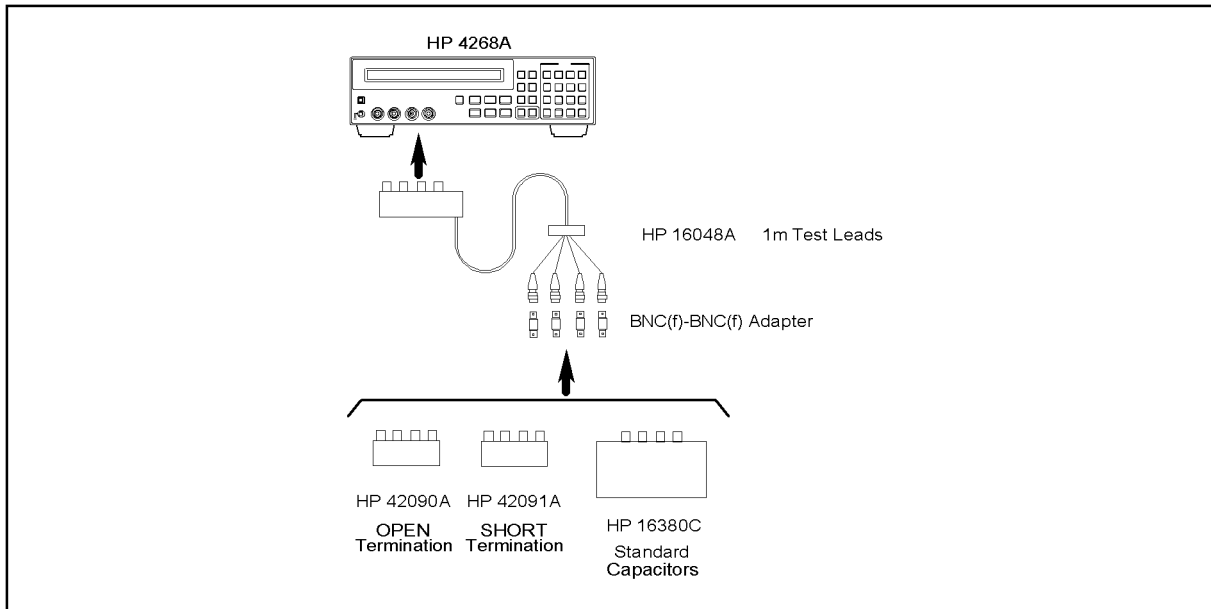

4268ASE02003

33. Press the **Open** key (blue key, **4** key) to display the OPEN correction menu.
34. Select OpenMeas using $\leftarrow\downarrow$ or $\uparrow\rightarrow$ key, and press **Enter**. The OPEN correction is performed.
35. Connect the SHORT termination to the 4268A's UNKNOWN terminals.
36. Press the **Short** key (blue key, **5** key) to display the SHORT correction menu.
37. Select ShortMeas using $\leftarrow\downarrow$ or $\uparrow\rightarrow$ key, and press **Enter**. The SHORT correction is performed.
38. Set the 4268A frequency to 120 Hz.
39. Set the 4268A's trigger mode to manual.
40. Connect the 1 μ F Standard Capacitor to the 4268A as shown in Figure 2-4.
41. Press **Trig** key to start the measurement.
42. Record the 4268A readings of C_p and D on the calculation sheet.
43. Calculate the test results according to the calculation sheet, and record the results into the performance test record.
44. Perform this test for all standards and frequency settings listed in Table 2-4

Table 2-4 Measurement Accuracy Test(1m, Capacitance) settings

Standard	Meas. Time	Signal Level	Frequency
1 μ F	MED	1000 mV	120 Hz
			1 kHz

Table 2-4 Measurement Accuracy Test(1m, Capacitance) settings

Standard	Meas. Time	Signal Level	Frequency
10 μ F	MED	1000 mV	120 Hz
			1 kHz

Measurement Accuracy Test(2m)

45. Reset the 4268A.
46. Set the cable length to 2m.
47. Connect the OPEN termination to the 4268A using the 2m test leads and four BNC(f)-BNC(f) adapters as shown in Figure 2-5

Figure 2-5 Measurement Accuracy Test(2 m) Setup

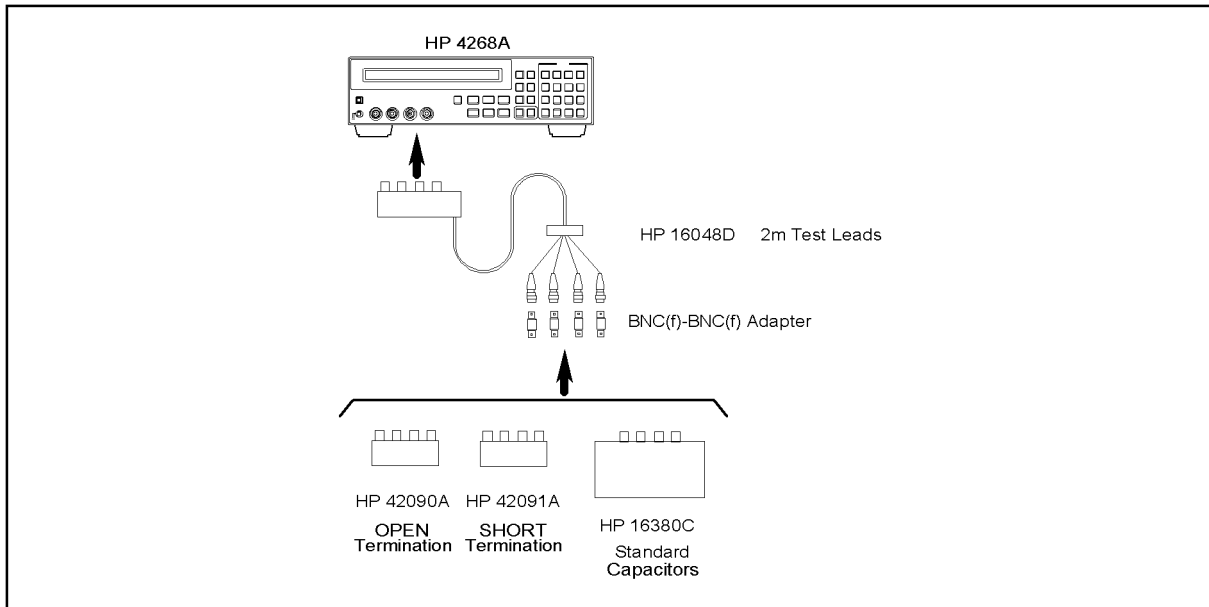

4268ASE02004

48. Press the **Open** key (blue key, **4** key) to display the OPEN correction menu.
49. Select OpenMeas using $\leftarrow\downarrow$ or $\uparrow\rightarrow$ key, and press **Enter**. The OPEN correction is performed.
50. Connect the SHORT termination to the 4268A's UNKNOWN terminals.
51. Press the **Short** key (blue key, **5** key) to display the SHORT correction menu.
52. Select ShortMeas using $\leftarrow\downarrow$ or $\uparrow\rightarrow$ key, and press **Enter**. The SHORT correction is performed.
53. Set the 4268A frequency to 120 Hz.
54. Set the 4268A's trigger mode to manual.
55. Connect the 1 μ F Standard Capacitor to the 4268A shown in Figure 2-5.

56. Press the **Trig** key to start the measurement.
57. Record the 4268A readings of Cp and D on the calculation sheet.
58. Calculate the test results according to the calculation sheet, and record the results into the performance test record.
59. Set the Frequency to 1 kHz, and perform step 56 to 58.

Function Test

Introduction

This section provides the test procedures used to verify the 4268A's performance characteristics and functions. The function test is recommended to be performed with the 4268A performance test.

Warm Up Time

Allow the 4268A to warm up for at least 30 minutes before you execute any of the function tests.

Ambient Conditions

Perform all performance tests in ambient conditions of $23\text{ }^{\circ}\text{C} \pm 5\text{ }^{\circ}\text{C}$, $\leq 70\%$ RH.

Signal Level Monitor Test

The 4268A's signal level monitor is measured with an AC voltmeter.

Performance Characteristic

Signal Level Monitor Accuracy: $\pm (2 \% + 2 \text{ mV})$

Test Equipment

Description	Recommended Model
AC Voltmeter	3458A
Interface Box	p/n 04284-65007
61 cm BNC(m)-BNC(m) Cable	p/n 8120-1839
Dual Banana-BNC(f) Adapter	p/n 1251-2277

Procedure

1. Reset the 4268A.
2. Set up the equipment as shown in Figure 2-6.

Figure 2-6 Signal Level Monitor Test Setup

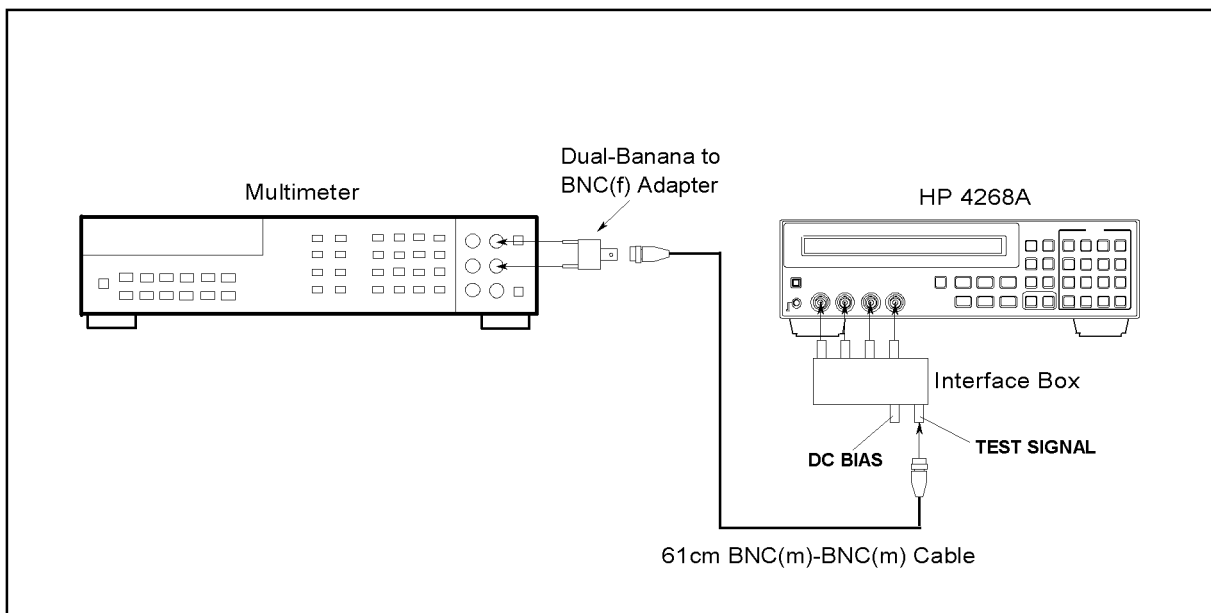

4268ASE02008

3. Set the 3458A Multimeter to the Synchronously Sub-sample AC voltage measurement mode using the following procedure:
 - a. Press the **ACV** key to set the measurement mode to AC voltage.

Maintenance
Function Test

- b. Press the **S** key (blue key, **N Rdgs/Trig** key), ↓, ↓, ↓ to display SETACV.
- c. Press →, ↓, ↓, ↓, to display SYNC, then press **Enter**.
- 4. Set the 4268A's trigger mode to manual.
- 5. Set the 4268A's frequency to 120 Hz.
- 6. Activate the 4268A's voltage monitor with the following procedure.
 - a. Press the **Level Mon** key (blue key, **ShowSetting** key).
 - b. Select Vmon using ←↓ or ↑→, and press the **Enter** key.
- 7. Record the Multimeter reading on the calculation sheet.
- 8. Press **Trig** key to start the measurement.
- 9. Record the 4268A reading of voltage monitor on the calculation sheet.
- 10. Calculate the output resistance according to the calculation sheet.
- 11. Perform step 7 and 8 for all settings listed in Table 2-5.

Table 2-5 Signal Level Monitor Test Settings

Signal Frequency	Means. Time	Signal Level
120 Hz	MED	1000 mV
120 Hz	SHORT	1000 mV 500 mV 300 mV 100 mV
1 kHz	SHORT	1000 mV 500 mV 300 mV 100 mV

- 12. If all test results are in the test limits, check pass into the function test record.

ALC Function Test

The 4268A's output impedance is measured when ALC function works.

Performance Characteristic

Output Resistance: $< 0.1 \Omega$

Test Equipment

Description	Recommended Model
Standard Resistor Set	42030A
OPEN Termination	42090A

Procedure

1. Reset the 4268A.
2. Set the 4268A's signal level to 500 mV.
3. Set the 4268A's frequency to 120 Hz.
4. Set the 4268A's measurement time mode to LONG.
5. Set the measurement parameters to Cs-Rs.
6. Set the 4268A's trigger mode to manual.
7. Activate the 4268A's voltage monitor with the following procedure.
 - a. Press the **Level Mon** key (blue key, **ShowSetting** key).
 - b. Select Vmon using $\leftarrow\downarrow$ or $\uparrow\rightarrow$, and press the **Enter** key.
8. Set the measurement range to 1 mF by using the following procedure.
 - a. Press the **Range Setup** key (blue key, **Auto/Hold** key).
 - b. Select 1 mF using $\leftarrow\downarrow$ or $\uparrow\rightarrow$, and press **Enter**.
9. Activate the ALC function.
10. Connect the OPEN termination as shown in Figure 2-7.

Figure 2-7 ALC Function Test Setup

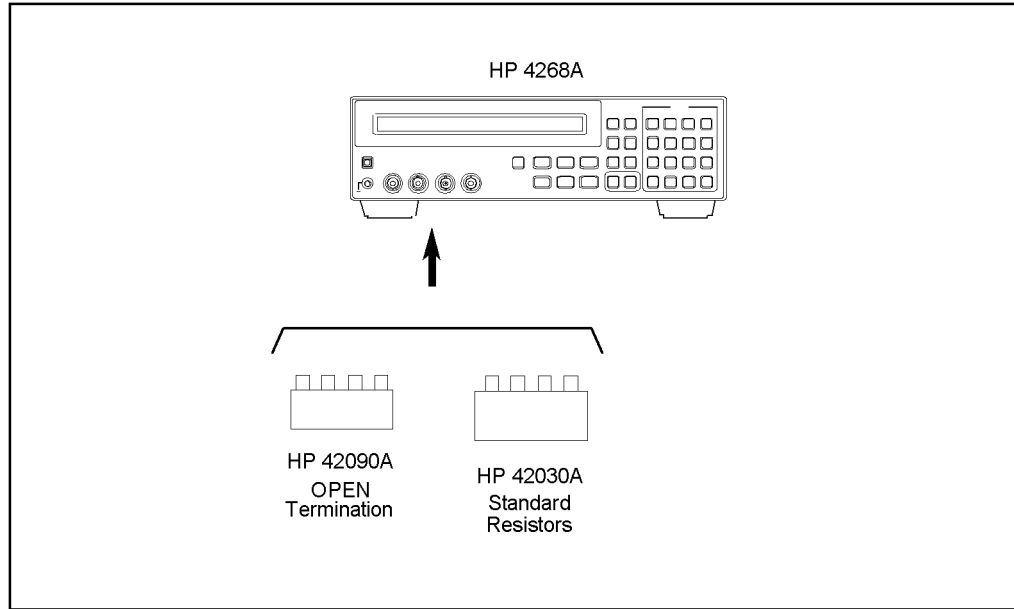

4268ASE02009

11. Press **Trig** key to start the measurement.
12. Record the voltage monitor reading on the calculation sheet.
13. Disconnect the OPEN termination, and connect the 1 Ω standard resistor.
14. Press **Trig** key to start the measurement.
15. Record the voltage monitor reading on the calculation sheet.
16. Calculate the output impedance according to the calculation sheet.
17. Set the measurement frequency to 1 kHz and the measurement range to 100 μ F.
18. Perform step 9 to 13.
19. If all test results are in the test limits, check pass into the function test record.

Contact Check Test

The 4268A's contact check function is tested, by breaking contact at the Lpot terminal. When the 4268A measures impedance correctly, the contact check function for the other three terminals will operate correctly.

Test Equipment

Description	Recommended Model
Standard Resistor Set	42030A
OPEN Termination	42090A
Test Leads, 1 m	16048A
Adapter BNC(f)-BNC(f)	p/n 1250-0080, 4 ea.

Procedure

1. Reset the 4268A.
2. Set the cable length to 1 m.
3. Connect the OPEN termination to the 4268A's UNKNOWN terminals using the 1 m test leads and four BNC(f)-BNC(f) adapters.

Figure 2-8 Contact Check Test Setup

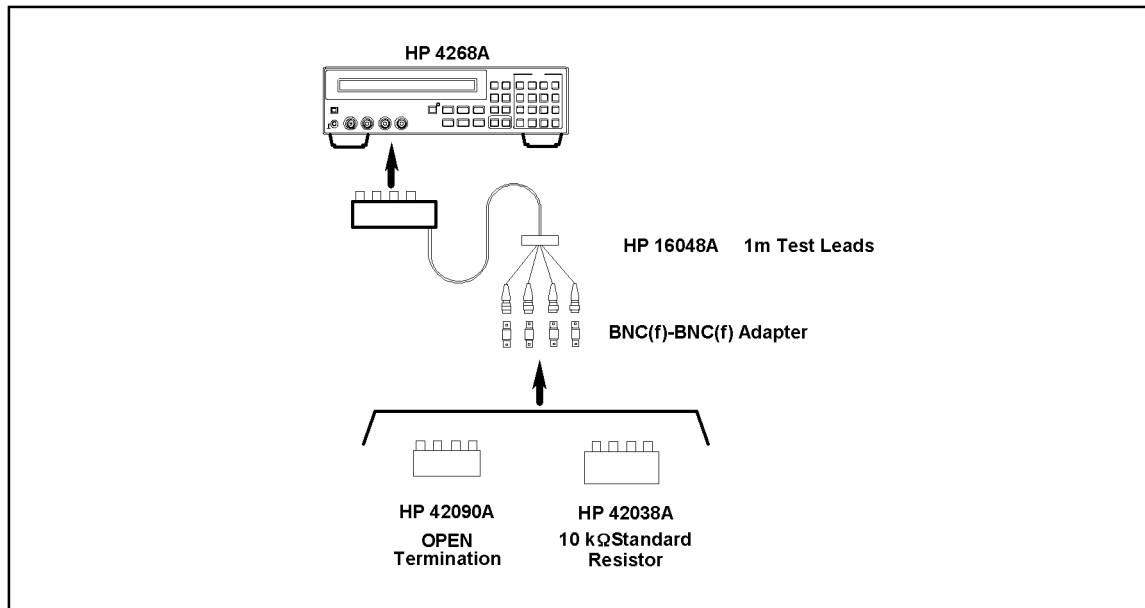

4268ase02007

4. Press **blue, 4** to display the OPEN correction menu.
5. Select OpenMeas and press **Enter**. The OPEN correction is performed.
6. Connect the 10 kΩ standard resistor instead of the OPEN termination.

Maintenance
Function Test

7. Press **Auto/Hold** to hold the measurement range.
8. Press **blue, 2** to activate the contact check function.
9. Confirm that the 4268A displays the measurement values.
10. Remove the test leads BNC connector from the Lpot terminal of the standard resistor.
11. Confirm that the 4268A displays N.C. (No Contact).
12. If contact check function work correctly, check pass into the function test record.

Handler Interface Test

The 4268A's handler interface function is tested using the built-in self-test and the handler interface simulator.

Test Equipment

Description	Recommended Model
Handler Interface Simulator	p/n 04278-65001

Procedure

Initial Setup

1. Turn the 4268A off.
2. Remove the 4268A outer cover.
3. Confirm jumpers(P17,P18, and P19), a switch(S2), and resistors(J12 and J13) on the 4268A A1 main board are the factory setting as shown in Figure 2-9. If they has been changed by customer, set them to the factory setting.

NOTE

Memorize the setting of the jumpers, the switch and the resistors, to reset them after this test, if necessary.

Figure 2-9 4268A A1 Main Board

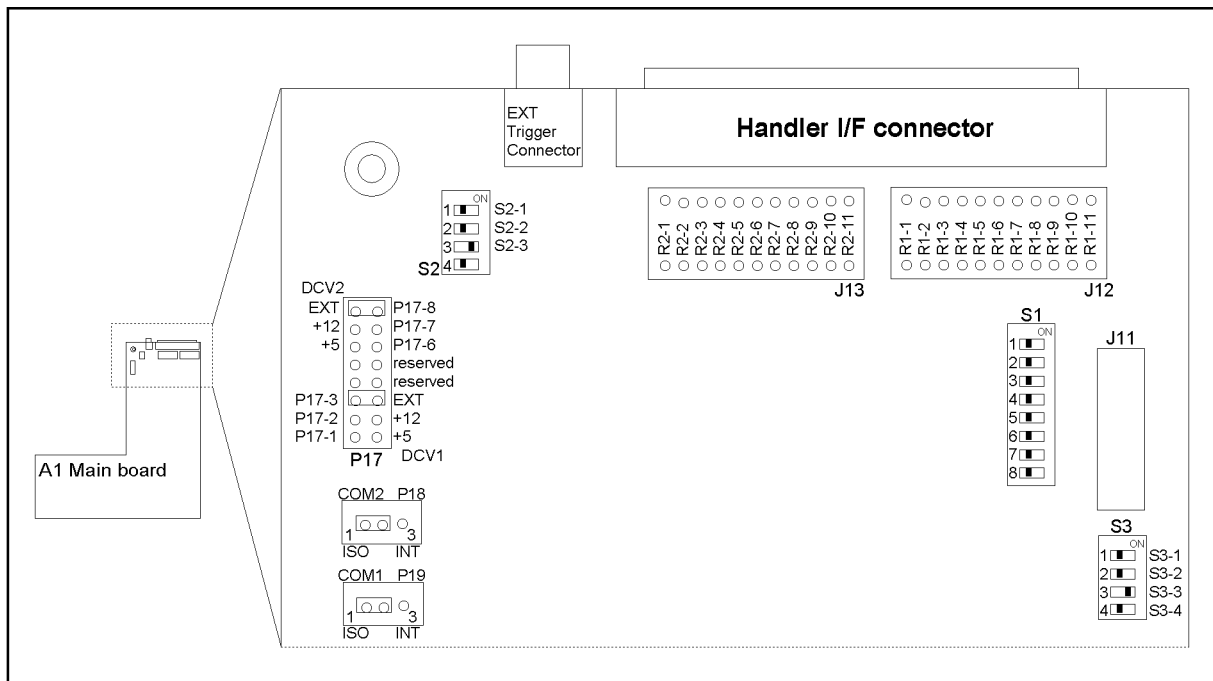

4268E0701

4. Confirm the LEDs on the handler interface simulator as shown in Figure 2-12 on page 39 is mounted. If all LEDs is not mounted, add LEDs (Agilent P/N

1990-0486).

5. Set up the equipment as shown in Figure 2-10

Figure 2-10 Handler Interface Test Setup

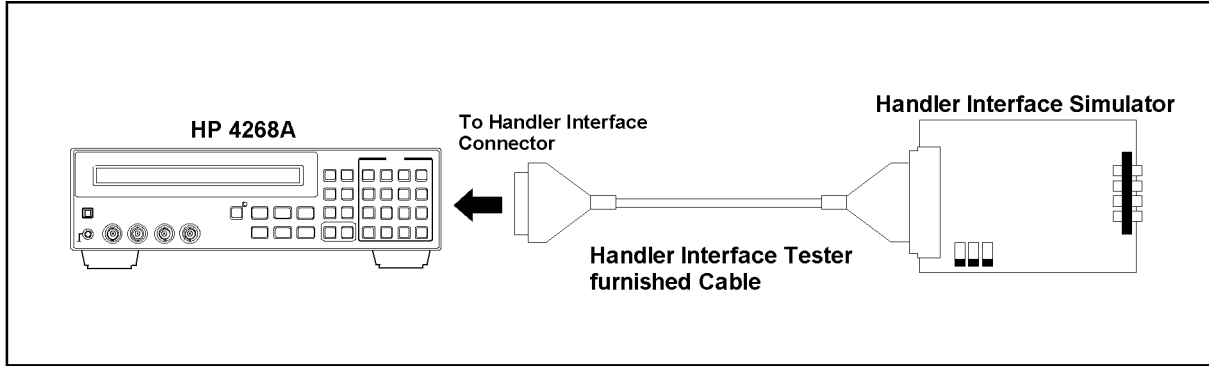

4268ase02005

6. Set START/STOP, CH.RESET, KEYLOCK- Switch as shown in Figure 2-11.

Figure 2-11 Handler Interface Simulator

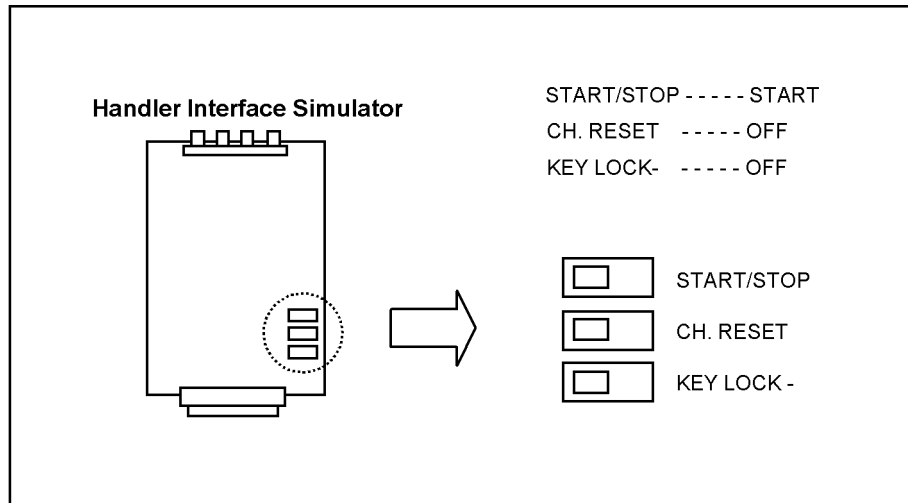

4268ase02010

7. Turn the 4268A on.
8. Reset the 4268A.
9. Confirm EOM,INDEX and CH2 light. The location are shown in Figure 2-12 on page 39.

Handler Interface Output Test

10. Start the handler interface output test with the following procedure.
 - a. Press the **Config** key (Blue key, -key) to display the configuration setting menu.
 - b. Select Svc using ←↓ or ↑→, and press **Enter**.

- c. Select HNDL using ←↓ or ↑→, and press **Enter**.
11. Confirm that the LEDs on the handler interface simulator light in the order shown in Figure 2-12, in accordance with the 4268A display.

Figure 2-12 LEDs of the Handler Interface Simulator

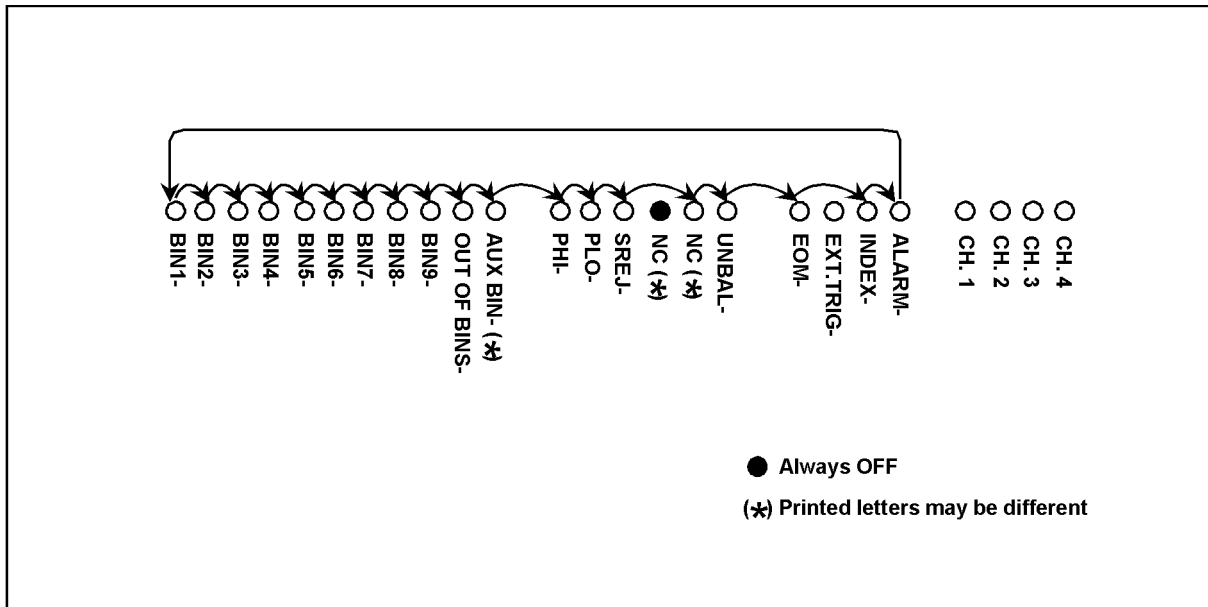

4268ase02006

12. Exit from the test mode by selecting Exit.

External Trigger Function Test

13. Set the trigger mode to External.
14. Set the comparator ON with the following procedure.
 - a. Press **Comprtr** key (blue key, **1** key) to display the comparator setting menu.
 - b. Select On/Off using ←↓ or ↑→, and press **Enter**.
 - c. Select On using ←↓ or ↑→, and press **Enter**.
15. Press blue key, **MeasTime** key, **5, 0, Enter** key to set the average to 50.
16. Set the START/STOP switch on the simulator to STOP then return to START.
17. Confirm the CH 1 to 4 take turns at lighting.

Key Lock Function Test

18. Set the trigger mode to Manual.
19. Set the KEYLOCK switch on the handler interface simulator to on.
20. Confirm that the all keys on the 4268A's front panel are locked out.
21. Set the KEYLOCK switch on the handler interface simulator to OFF.

Maintenance
Function Test

Record the result

22. If all test work correctly, check pass into the function test record.

Scanner Interface Test (opt. 001 only)

The 4268A's scanner interface function is tested using the built-in self-test and the scanner interface simulator.

Test Equipment

Description	Recommended Model
Scanner Interface Simulator	p/n 04278-65301
36 Pin Cable	p/n 04278-61650 ^a

a. Part of the Handler Interface Simulator

Procedure

1. Turn the 4268A off.
2. Confirm switches S1 and S3 on the 4268A A1 main board are the factory setting as shown in Figure 2-9. If they have been changed by customer, set them to the factory setting.

NOTE

Memorize the switch setting to reset them after this test, if necessary.

3. Set up the equipment as shown in Figure 2-13.

Figure 2-13 Scanner Interface Test Setup

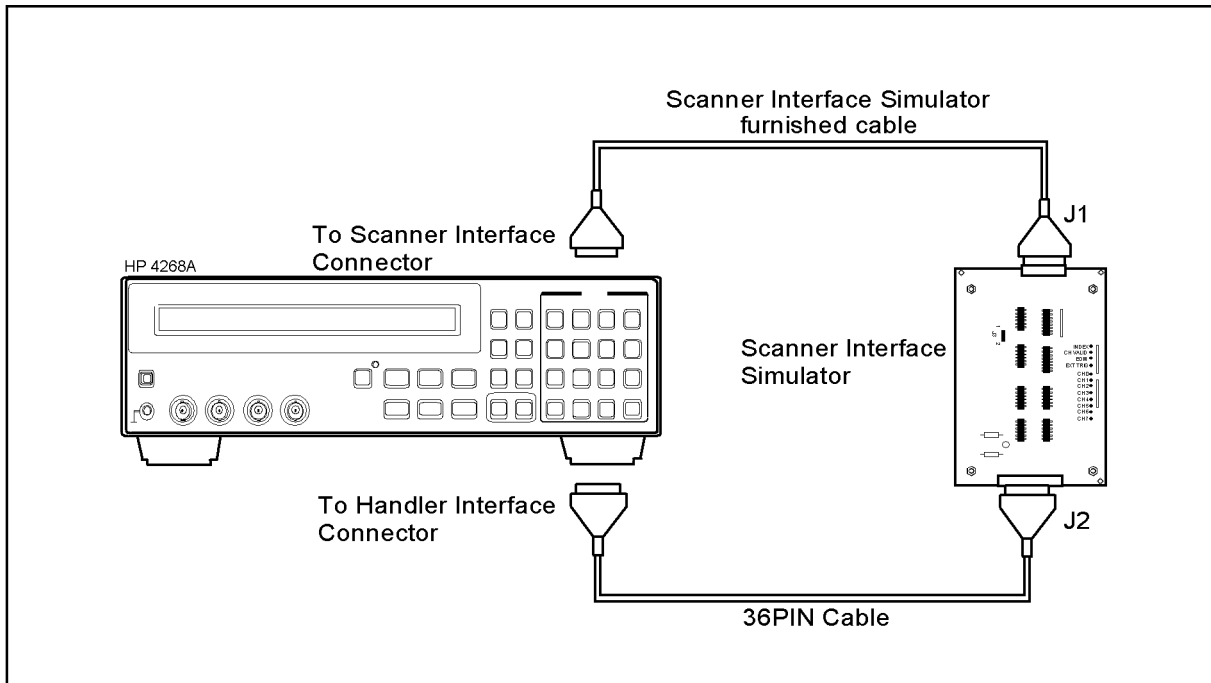

4268ase02012

- Set the jumper on the scanner interface simulator to 1 as shown in Figure 2-14.

Figure 2-14 Scanner Interface Simulator Setting

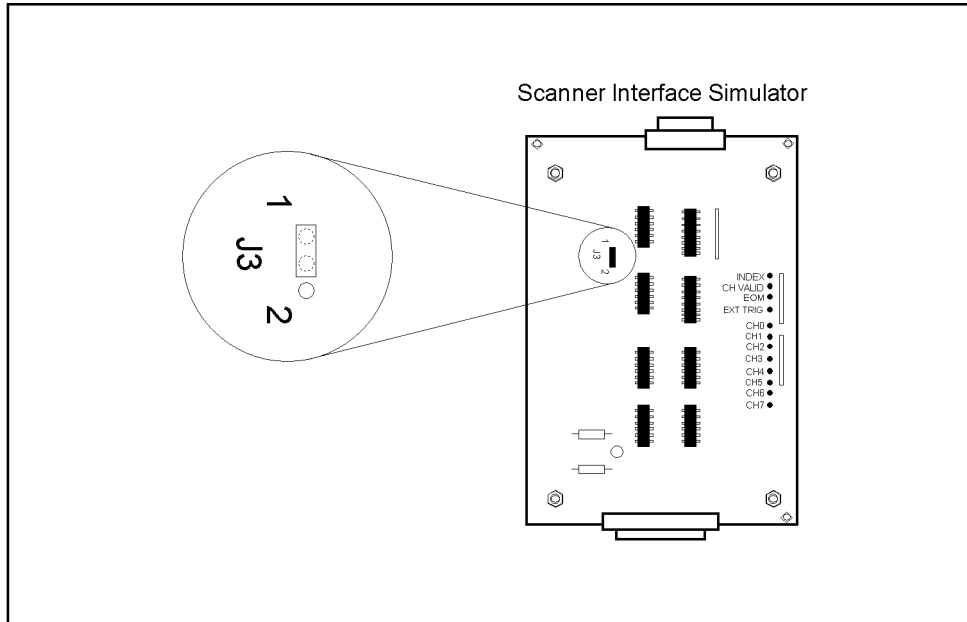

4268ase02013

- Turn the 4268A on.
- Reset the 4268A.
- Start the scanner interface output test with the following procedure.
 - Press the **Config** key (Blue key, - key) to display the configuration setting menu.
 - Select Svc using ←↓ or ↑→, and press **Enter**.
 - Select SCNR using ←↓ or ↑→, and press **Enter**.
- Confirm that the LEDs on the scanner interface simulator light in the order shown in Figure 2-15, in accordance with the 4268A display.

Figure 2-15 Scanner Interface Output Order

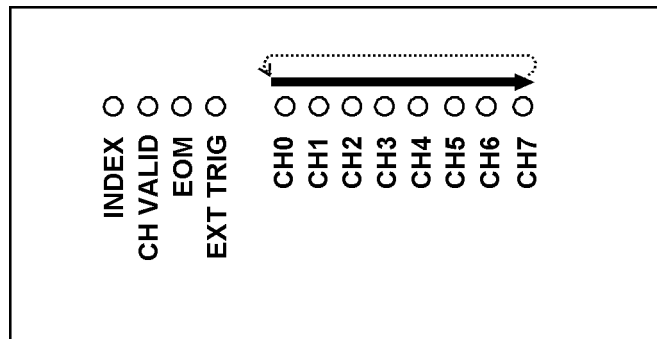

4268ase02011

NOTE

Generally when CH n LED light, “CH 2 n ” is displayed on the 4268A’s LCD. However, when CH6 or CH7 LED light, “CH 0” is displayed.

9. If the 4268A test work correctly, check pass onto the function test record.

Calculation Sheet

Performance Test

Frequency Accuracy Test

Frequency	Counter Reading [a]	Test Result Equation
120 Hz	Hz	$a - 120.0 \text{ Hz}$
1 kHz	kHz	$a - 1.00000 \text{ kHz}$

Signal Level Accuracy Test

Frequency	Signal Level	Multimeter Reading [a]	Test Result Equation
120 Hz	1000 mV	V	$(a - 1.00) \times 1000 \text{ mV}$
120 Hz	500 mV	V	$(a - 0.500) \times 1000 \text{ mV}$
120 Hz	100 mV	V	$(a - 0.100) \times 1000 \text{ mV}$
1 kHz	1000 mV	V	$(a - 1.00) \times 1000 \text{ mV}$
1 kHz	500 mV	V	$(a - 0.500) \times 1000 \text{ mV}$
1 kHz	100 mV	V	$(a - 0.100) \times 1000 \text{ mV}$

Standard's Calibration Values

This table is used in Measurement Accuracy Tests.

Standard	Frequency	Parameter	Calibration Value	Reference Designation
1000 pF	1 kHz	Cp	pF	CV1
1000 pF	1 kHz	D		CV2
0.01 μ F	120 Hz	Cp	nF	CV3
0.01 μ F	120 Hz	D		CV4
0.01 μ F	1 kHz	Cp	nF	CV5
0.01 μ F	1 kHz	D		CV6
0.1 μ F	120 Hz	Cp	nF	CV7
0.1 μ F	120 Hz	D		CV8
0.1 μ F	1 kHz	Cp	nF	CV9
0.1 μ F	1 kHz	D		CV10
1 μ F	120 Hz	Cp	μ F	CV11
1 μ F	120 Hz	D		CV12
1 μ F	1 kHz	Cp	μ F	CV13
1 μ F	1 kHz	D		CV14
10 μ F	120 Hz	Cp	μ F	CV15
10 μ F	120 Hz	D		CV16
10 μ F	1 kHz	Cp	μ F	CV17
10 μ F	1 kHz	D		CV18
100 Ω	DC	Rs	Ω	CV19
10 Ω	DC	Rs	Ω	CV20
1 Ω	DC	Rs	Ω	CV21

Maintenance
Calculation Sheet

Measurement Accuracy Test (0 m, 1000 pF, Meas. Time : MED, ALC : OFF)

Frequency	Signal Level	Parameter Measured	4268A Reading [a]	Test Result Equation
1 kHz	1000 mV	Cp	pF	a – CV1
1 kHz	1000 mV	D		a – CV2

Measurement Accuracy Test (0 m, 0.01 μF, Meas. Time : MED, ALC : OFF)

Frequency	Signal Level	Parameter Measured	4268A Reading [a]	Test Result Equation
120 Hz	1000 mV	Cp	nF	a – CV3
120 Hz	1000 mV	D		a – CV4
1 kHz	1000 mV	Cp	nF	a – CV5
1 kHz	1000 mV	D		a – CV6

Measurement Accuracy Test (0 m, 0.1 μF, Meas. Time : MED, ALC : OFF)

Frequency	Signal Level	Parameter Measured	4268A Reading [a]	Test Result Equation
120 Hz	1000 mV	Cp	nF	a – CV7
120 Hz	1000 mV	D		a – CV8
1 kHz	1000 mV	Cp	nF	a – CV9
1 kHz	1000 mV	D		a – CV10

Measurement Accuracy Test (0 m, 1 μ F, ALC : OFF)

Frequency	Signal Level	Meas. Time	Parameter Measured	4268A Reading [a]	Test Result Equation
120 Hz	1000 mV	MED	Cp	μ F	a – CV11
120 Hz	1000 mV	MED	D		a – CV12
1 kHz	1000 mV	MED	Cp	μ F	a – CV13
1 kHz	1000 mV	MED	D		a – CV14
120 Hz	500 mV	MED	Cp	μ F	a – CV11
120 Hz	500 mV	MED	D		a – CV12
1 kHz	500 mV	MED	Cp	μ F	a – CV13
1 kHz	500 mV	MED	D		a – CV14
120 Hz	300 mV	MED	Cp	μ F	a – CV11
120 Hz	300 mV	MED	D		a – CV12
1 kHz	300 mV	MED	Cp	μ F	a – CV13
1 kHz	300 mV	MED	D		a – CV14
120 Hz	100 mV	MED	Cp	μ F	a – CV11
120 Hz	100 mV	MED	D		a – CV12
1 kHz	100 mV	MED	Cp	μ F	a – CV13
1 kHz	100 mV	MED	D		a – CV14
120 Hz	1000 mV	LONG	Cp	μ F	a – CV11
120 Hz	1000 mV	LONG	D		a – CV12
1 kHz	1000 mV	LONG	Cp	μ F	a – CV13
1 kHz	1000 mV	LONG	D		a – CV14
120 Hz	1000 mV	SHORT	Cp	μ F	a – CV11
120 Hz	1000 mV	SHORT	D		a – CV12
1 kHz	1000 mV	SHORT	Cp	μ F	a – CV13
1 kHz	1000 mV	SHORT	D		a – CV14

Maintenance
Calculation Sheet

Measurement Accuracy Test (0 m, 1 μ F, Meas. Time : MED, ALC : OFF, Sync. Source Function : ON)

Frequency	Signal Level	Parameter Measured	4268A Reading [a]	Test Result Equation
120 Hz	1000 mV	Cp	μ F	a – CV11
120 Hz	1000 mV	D		a – CV12
1 kHz	1000 mV	Cp	μ F	a – CV13
1 kHz	1000 mV	D		a – CV14

Measurement Accuracy Test (0 m, 100 Ω , Meas. Time : MED, ALC : OFF)

Frequency	Signal Level	Parameter Measured	4268A Reading [a]	Test Result Equation
120 Hz	1000 mV	Rs	Ω	a – CV19

Measurement Accuracy Test (0 m, 10 Ω , Meas. Time : MED, ALC : OFF)

Frequency	Signal Level	Parameter Measured	4268A Reading [a]	Test Result Equation
120 Hz	1000 mV	Rs	Ω	a – CV20
1 kHz	1000 mV	Rs	Ω	a – CV20

Measurement Accuracy Test (0 m, 1 Ω , Meas. Time : MED, ALC : OFF)

Frequency	Signal Level	Parameter Measured	4268A Reading [a]	Test Result Equation
120 Hz	1000 mV	Rs	Ω	a – CV21
1 kHz	1000 mV	Rs	Ω	a – CV21

Measurement Accuracy Test (0 m, 1 Ω , Meas. Time : MED, ALC : ON)

Frequency	Signal Level	Parameter Measured	4268A Reading [a]	Test Result Equation
120 Hz	1000 mV	Rs	Ω	a – CV21
1 kHz	1000 mV	Rs	Ω	a – CV21

Measurement Accuracy Test (1 m, 1 μ F, Meas. Time : MED, ALC : OFF)

Frequency	Signal Level	Parameter Measured	4268A Reading [a]	Test Result Equation
120 Hz	1000 mV	Cp	μ F	a – CV11
120 Hz	1000 mV	D		a – CV12
1 kHz	1000 mV	Cp	μ F	a – CV13
1 kHz	1000 mV	D		a – CV14

Measurement Accuracy Test (1 m, 10 μ F, Meas. Time: MED, ALC : OFF)

Frequency	Signal Level	Parameter Measured	4268A Reading [a]	Test Result Equation
120 Hz	1000 mV	Cp	μ F	a – CV15
120 Hz	1000 mV	D		a – CV16
1 kHz	1000 mV	Cp	μ F	a – CV17
1 kHz	1000 mV	D		a – CV18

Measurement Accuracy Test (2 m, 1 μ F, Meas. Time : MED, ALC : OFF)

Frequency	Signal Level	Parameter Measured	4268A Reading [a]	Test Result Equation
120 Hz	1000 mV	Cp	μ F	a – CV11
120 Hz	1000 mV	D		a – CV12
1 kHz	1000 mV	Cp	μ F	a – CV13
1 kHz	1000 mV	D		a – CV14

Function Test

Level Monitor Test

Frequency	Signal Level	Meas. Time	Multimeter Reading [x]	4268A Voltage Monitor Reading [y]	Test Result [x - y]	Test Limits
120 Hz	1000 mV	MED	mV	mV	mV	± 22 mV
120 Hz	1000 mV	SHORT	mV	mV	mV	± 22 mV
120 Hz	500 mV	SHORT	mV	mV	mV	± 12 mV
120 Hz	300 mV	SHORT	mV	mV	mV	± 8 mV
120 Hz	100 mV	SHORT	mV	mV	mV	± 4 mV
1 kHz	1000 mV	SHORT	mV	mV	mV	± 22 mV
1 kHz	500 mV	SHORT	mV	mV	mV	± 12 mV
1 kHz	300 mV	SHORT	mV	mV	mV	± 8 mV
1 kHz	100 mV	SHORT	mV	mV	mV	± 4 mV

ALC Function Test

Frequency	Range	Voltage Monitor Reading (OPEN) [x]	Voltage Monitor Reading (1Ω) [y]	Test Limit (lower)	Output Impedance ^a	Test Limit (upper)
120 Hz	1 mF	mV	mV	0.00 Ω	Ω	0.10 Ω
1 kHz	100 μF	mV	mV	0.00 Ω	Ω	0.10 Ω

a. $1 \times (x - y) / y$

Test Record

4268A 120 Hz/ 1 kHz Capacitance Meter

Serial Number:			
Temperature:		Date:	
Humidity:		Tested by:	

Performance Test Record

Frequency Accuracy Test

Frequency	Test Limits	Test Result	Measurement Uncertainty
120 Hz	± 1.2 Hz	Hz	± 0.014 Hz
1 kHz	± 0.50 Hz	Hz	± 0.12 Hz

Signal Level Accuracy Test

Frequency	Signal Level	Test Limits	Test Result	Measurement Uncertainty
120 Hz	1000 mV	± 100 mV	mV	± 0.11 mV
120 Hz	500 mV	± 50 mV	mV	± 0.065 mV
120 Hz	100 mV	± 10 mV	mV	± 0.011 mV
1 kHz	1000 mV	± 100 mV	mV	± 0.11 mV
1 kHz	500 mV	± 50 mV	mV	± 0.065 mV
1 kHz	100 mV	± 10 mV	mV	± 0.011 mV

Maintenance
Test Record

Measurement Accuracy Test (0 m, 1000 pF, Meas. Time : MED, ALC : OFF)

Frequency	Signal Level	Parameter Measured	Test Limits	Test Result	Measurement Uncertainty
1 kHz	1000 mV	Cp	± 1.9 pF	pF	± 0.18 pF
1 kHz	1000 mV	D	± 0.0019		± 0.00003

Measurement Accuracy Test (0 m, 0.01 μF, Meas. Time : MED, ALC : OFF)

Frequency	Signal Level	Parameter Measured	Test Limits	Test Result	Measurement Uncertainty
120 Hz	1000 mV	Cp	± 0.019 nF	nF	± 0.0021 nF
120 Hz	1000 mV	D	± 0.0019		± 0.00002
1 kHz	1000 mV	Cp	± 0.018 nF	nF	± 0.0021 nF
1 kHz	1000 mV	D	± 0.0018		± 0.00004

Measurement Accuracy Test (0 m, 0.1 μF, Meas. Time : MED, ALC : OFF)

Frequency	Signal Level	Parameter Measured	Test Limits	Test Result	Measurement Uncertainty
120 Hz	1000 mV	Cp	± 0.18 nF	nF	± 0.021 nF
120 Hz	1000 mV	D	± 0.0018		± 0.00003
1 kHz	1000 mV	Cp	± 0.18 nF	nF	± 0.021 nF
1 kHz	1000 mV	D	± 0.0018		± 0.00003

Measurement Accuracy Test (0 m, 1 μ F, ALC : OFF)

Frequency	Signal Level	Meas. Time	Parameter Measured	Test Limits	Test Result	Measurement Uncertainty
120 Hz	1000 mV	MED	Cp	$\pm 0.0020 \mu\text{F}$	μF	$\pm 0.00021 \mu\text{F}$
120 Hz	1000 mV	MED	D	± 0.0020		± 0.00004
1 kHz	1000 mV	MED	Cp	$\pm 0.0018 \mu\text{F}$	μF	$\pm 0.00021 \mu\text{F}$
1 kHz	1000 mV	MED	D	± 0.0018		± 0.00003
120 Hz	500 mV	MED	Cp	$\pm 0.0020 \mu\text{F}$	μF	$\pm 0.00021 \mu\text{F}$
120 Hz	500 mV	MED	D	± 0.0020		± 0.00004
1 kHz	500 mV	MED	Cp	$\pm 0.0018 \mu\text{F}$	μF	$\pm 0.00021 \mu\text{F}$
1 kHz	500 mV	MED	D	± 0.0018		± 0.00004
120 Hz	300 mV	MED	Cp	$\pm 0.0020 \mu\text{F}$	μF	$\pm 0.00021 \mu\text{F}$
120 Hz	300 mV	MED	D	± 0.0020		± 0.00005
1 kHz	300 mV	MED	Cp	$\pm 0.0018 \mu\text{F}$	μF	$\pm 0.00021 \mu\text{F}$
1 kHz	300 mV	MED	D	± 0.0018		± 0.00003
120 Hz	100 mV	MED	Cp	$\pm 0.0027 \mu\text{F}$	μF	$\pm 0.00023 \mu\text{F}$
120 Hz	100 mV	MED	D	± 0.0027		± 0.00009
1 kHz	100 mV	MED	Cp	$\pm 0.0025 \mu\text{F}$	μF	$\pm 0.00022 \mu\text{F}$
1 kHz	100 mV	MED	D	± 0.0025		± 0.00005
120 Hz	1000 mV	LONG	Cp	$\pm 0.0020 \mu\text{F}$	μF	$\pm 0.00021 \mu\text{F}$
120 Hz	1000 mV	LONG	D	± 0.0020		± 0.00004
1 kHz	1000 mV	LONG	Cp	$\pm 0.0018 \mu\text{F}$	μF	$\pm 0.00021 \mu\text{F}$
1 kHz	1000 mV	LONG	D	± 0.0018		± 0.00003
120 Hz	1000 mV	SHORT	Cp	$\pm 0.0036 \mu\text{F}$	μF	$\pm 0.00022 \mu\text{F}$
120 Hz	1000 mV	SHORT	D	± 0.0036		± 0.00009
1 kHz	1000 mV	SHORT	Cp	$\pm 0.0022 \mu\text{F}$	μF	$\pm 0.00021 \mu\text{F}$
1 kHz	1000 mV	SHORT	D	± 0.0022		± 0.00005

Maintenance
Test Record

Measurement Accuracy Test (0 m, 1 μ F, Meas. Time : MED, ALC : OFF, Sync. Source Function : ON)

Frequency	Signal Level	Parameter Measured	Test Limits	Test Result	Measurement Uncertainty
120 Hz	1000 mV	Cp	$\pm 0.0020 \mu\text{F}$	μF	$\pm 0.00021 \mu\text{F}$
120 Hz	1000 mV	D	± 0.0020		± 0.00004
1 kHz	1000 mV	Cp	$\pm 0.0018 \mu\text{F}$	μF	$\pm 0.00021 \mu\text{F}$
1 kHz	1000 mV	D	± 0.0018		± 0.00004

Measurement Accuracy Test (0 m, 100 Ω , Meas. Time : MED, ALC : OFF)

Frequency	Signal Level	Parameter Measured	Test Limits	Test Result	Measurement Uncertainty
120 Hz	1000 mV	Rs	$\pm 0.20 \Omega$	Ω	$\pm 0.015 \Omega$

Measurement Accuracy Test (0 m, 10 Ω , Meas. Time : MED, ALC : OFF)

Frequency	Signal Level	Parameter Measured	Test Limits	Test Result	Measurement Uncertainty
120 Hz	1000 mV	Rs	$\pm 0.044 \Omega$	Ω	$\pm 0.0021 \Omega$
1 kHz	1000 mV	Rs	$\pm 0.018 \Omega$	Ω	$\pm 0.0021 \Omega$

Measurement Accuracy Test (0 m, 1 Ω , Meas. Time : MED, ALC : OFF)

Frequency	Signal Level	Parameter Measured	Test Limits	Test Result	Measurement Uncertainty
120 Hz	500 mV	Rs	$\pm 0.0097 \Omega$	Ω	$\pm 0.00067 \Omega$
1 kHz	500 mV	Rs	$\pm 0.0057 \Omega$	Ω	$\pm 0.00067 \Omega$

Measurement Accuracy Test (0 m, 1 Ω , Meas. Time : MED, ALC : ON)

Frequency	Signal Level	Parameter Measured	Test Limits	Test Result	Measurement Uncertainty
120 Hz	500 mV	Rs	$\pm 0.0097 \Omega$	Ω	$\pm 0.00067 \Omega$
1 kHz	500 mV	Rs	$\pm 0.0057 \Omega$	Ω	$\pm 0.00067 \Omega$

Measurement Accuracy Test (1 m, 1 μ F, Meas. Time : MED, ALC : OFF)

Frequency	Signal Level	Parameter Measured	Test Limits	Test Result	Measurement Uncertainty
120 Hz	1000 mV	Cp	$\pm 0.0020 \mu\text{F}$	μF	$\pm 0.00021 \mu\text{F}$
120 Hz	1000 mV	D	± 0.0020		± 0.00014
1k Hz	1000 mV	Cp	$\pm 0.0018 \mu\text{F}$	μF	$\pm 0.00021 \mu\text{F}$
1k Hz	1000 mV	D	± 0.0018		± 0.00010

Measurement Accuracy Test (1 m, 10 μ F, Meas. Time : MED, ALC : OFF)

Frequency	Signal Level	Parameter Measured	Test Limits	Test Result	Measurement Uncertainty
120 Hz	1000 mV	Cp	$\pm 0.020 \mu\text{F}$	μF	$\pm 0.0021 \mu\text{F}$
120 Hz	1000 mV	D	± 0.0020		± 0.00004
1 kHz	1000 mV	Cp	$\pm 0.018 \mu\text{F}$	μF	$\pm 0.0021 \mu\text{F}$
1 kHz	1000 mV	D	± 0.0018		± 0.00004

Measurement Accuracy Test (2 m, 1 μ F, Meas. Time : MED, ALC : OFF)

Frequency	Signal Level	Parameter Measured	Test Limits	Test Result	Measurement Uncertainty
120 Hz	1000 mV	Cp	$\pm 0.0020 \mu\text{F}$	μF	$\pm 0.00021 \mu\text{F}$
120 Hz	1000 mV	D	± 0.0020		± 0.00015
1k Hz	1000 mV	Cp	$\pm 0.0018 \mu\text{F}$	μF	$\pm 0.00021 \mu\text{F}$
1k Hz	1000 mV	D	± 0.0018		± 0.00010

Function Test Record

Signal Level Monitor Test

Pass	Fail
[]	[]

ALC Function Test

Pass	Fail
[]	[]

Contact Check Test

Pass	Fail
[]	[]

Handler Interface Test

Pass	Fail
[]	[]

Scanner Interface Test(Opt. 001 only)

Pass	Fail
[]	[]

3 Adjustment

This chapter provides information on the adjustment required to ensure the 4268A is within its published specifications after it has been repaired, or when it fails the performance tests. The adjustments should be performed along with periodic maintenance to keep the 4268A in optimum operating condition. If proper performance cannot be achieved after adjustments, proceed to Chapter 4.

Required Controller

Performing adjustments requires the following controller:

Windows PC(Personal Computer)

Computer	PC-AT compatible, RAM:64Mbytes, CPU:Pentium200MHz
OS	Microsoft Windows NT®(≥4.0), Windows 95®
Software	Agilent VEE(≥4.0)
GPIB Card	82350, 82340, 82341

Required Equipment

The required equipment is listed on Table 1-1 on page 11. Use only calibrated equipment when adjusting the 4268A.

Adjustment Program

The adjustment program is required for the adjustments. Using the program, the computer controls the 4268A and the other pieces of equipment to obtain the adjustment data, and stores the data in the 4268A internal EEPROM

The adjustment program runs on the computer listed in Required Controller. The program should be installed into your computer according to the procedure described in *Program Installation*. To start the program after it has been installed, refer to *Program Execution*.

Figure 3-1 shows the adjustment program flow. The following lists the brief explanation for each menu item. At the end of each adjustment data both to the 4268A internal EEPROM.

Figure 3-1 Adjustment Program Flow

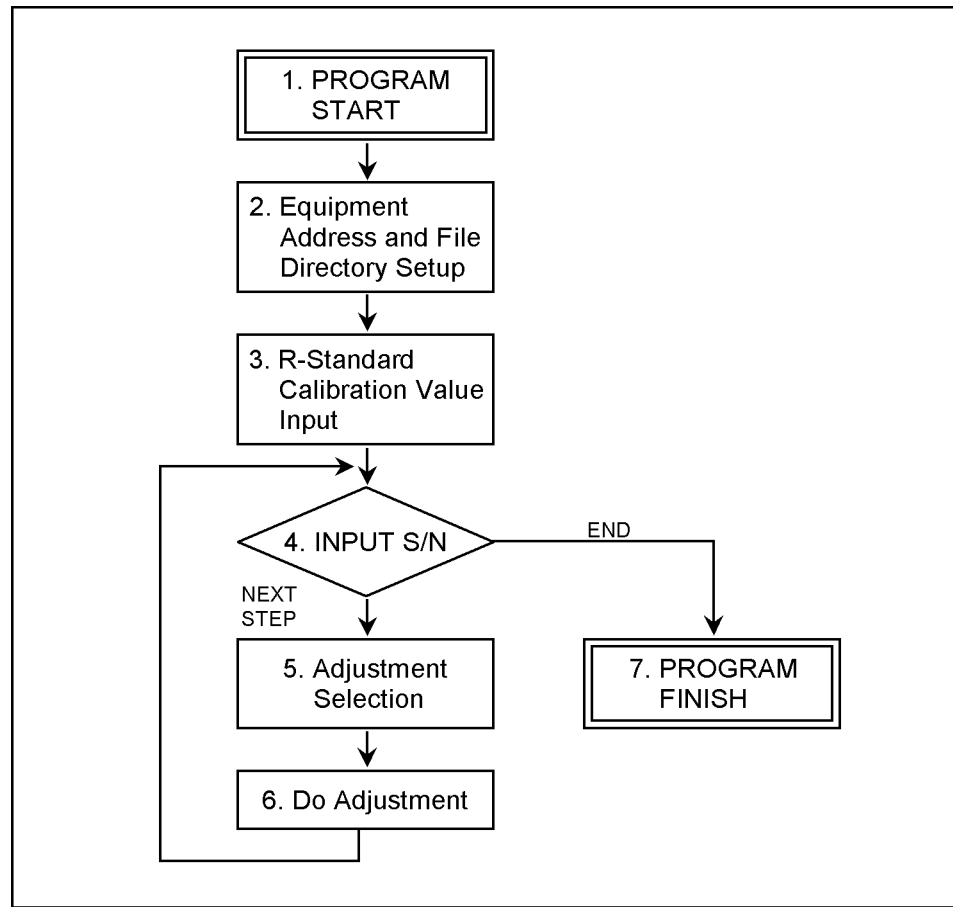

4268ASE03003

Table 3-1 Title of the adjustment in the program

	Title in the adjustment program	Description
Firmware Installation	FW_INSTALL	updates the 4268A firmware
Signal Level Adjustment	Adj_SigLevel	obtains the data to adjust the actual signal source output voltage to the set value.
Signal Level Monitor Adjustment	Adj_LvlMonitor	obtains the data to adjust the signal level monitor to the signal source output voltage.
Impedance Measurement Adjustment	Adj_OPEN_0m Adj_SHORT_0m Adj_OPEN_1m Adj_SHORT_1m Adj_OPEN_2m Adj_SHORT_2m Adj_GAMMA	obtains the data to adjust the actual measurement impedance to the standard's value for no test cable, 1m, 2m.test cable.

Program Installation

1. Make a copy of the 4268A adjustment and performance test program named adj4268a.exe in a directory of your hard disk drive.
2. Double-click the filename on the Windows' Explorer to start extracting the self-extracting the self-extracting archive.
3. You will be prompted to enter directory name for installing the program files. Click Unzip to use default directory (C:\4268a)
4. Confirm the message that you successfully extract the files and click OK and CLOSE.

Running the Adjustment Program

1. Start the Agilent VEE
2. Load the adjustment program file into the Agilent VEE as follows:
 - a. Full down the file menu from the Agilent VEE window and select Open.
 - b. Select C:\4268A\4268AADJ.VEE and select Open.
3. You may be asked to add drivers for the equipment during the program loading. Click OK and enter the address for each equipment.

Table 3-2 Device name and GPIB address example

Device Name	Equipment	GPIB address
4268A	4268A	717
3458A	Multimeter	722
RS232	not used	0

4. Select Start button on the Agilent VEE screen.
5. Follow the instructions shown on the display.

Adjustment Procedure Reference

This section provides supplemental information for the adjustments which are performed by the program. Connection instructions and some additional explanations are provided. Use this chapter as a reference when performing the adjustments.

Signal Level Adjustment

This adjustment updates the signal level adjustment data stored in the EEPROM. The data adjust the actual signal source level to the set value.

Equipment

Description	Recommended Model
Multimeter	3458A
61 cm BNC(m)-BNC(m) Cable	p/n 8120-1839
Dual Banana-BNC(f) Adapter	p/n 1251-2277

Setup

Perform the following steps as the program instructs.

1. Connect the Dual Banana-BNC(f) Adapter to the BNC(m)-BNC(m) Cable.
2. Connect the Dual Banana-BNC(f) Adapter to the 3458A's INPUT binding posts.
3. Connect another end of the BNC(m)-BNC(m) Cable to the 4268A's H_{CUR} Connector.

Figure 3-2 Signal Level Adjustment Setup

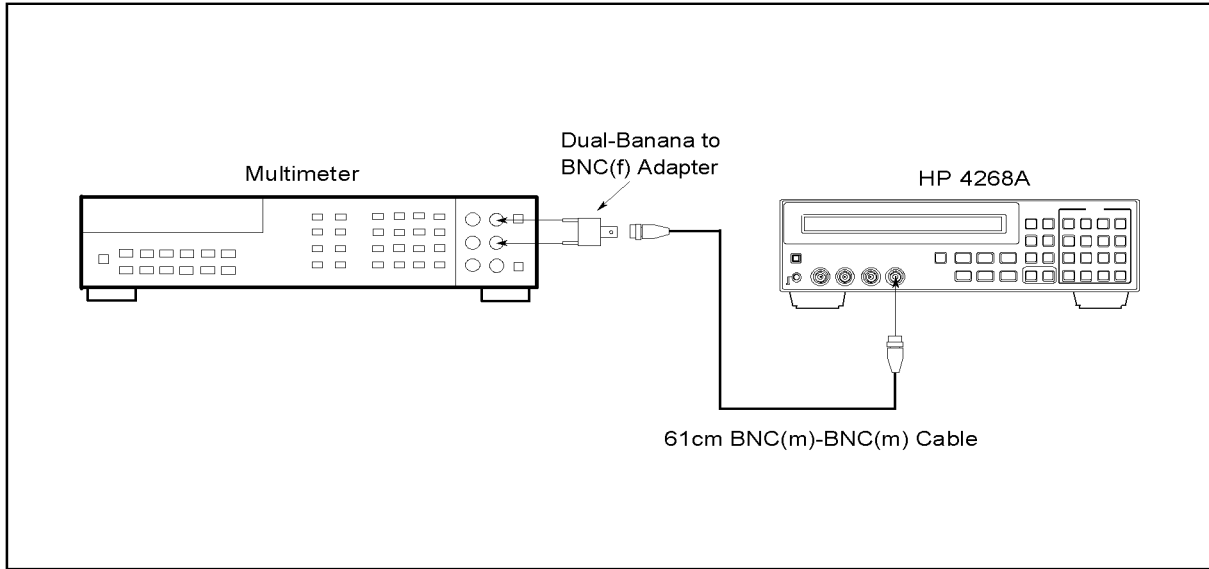

4268ASE02001

Signal Level Monitor Adjustment

This adjustment updates the signal level monitor adjustment data stored in the EEPROM. The data adjust the actual signal level to the set value.

Equipment

Description	Recommended Model
Multimeter	3458A
Interface Box	p/n 04284-65007
61 cm BNC(m)-BNC(m) Cable	p/n 8120-1839
Dual Banana-BNC(f) Adapter	p/n 1251-2277

Setup

Perform the following steps as the program instructs.

1. Connect the interface box to the 4268A UNKOWN terminal.
2. Connect the Dual Banana-BNC(f) Adapter to the BNC(m)-BNC(m) Cable.
3. Connect the Dual Banana-BNC(f) Adapter to the 3458A's INPUT binding posts.
4. Connect another end of the BNC(m)-BNC(m) Cable to the interface box's TEST SIGNAL connector.

Figure 3-3 Signal Level Monitor Adjustment Setup

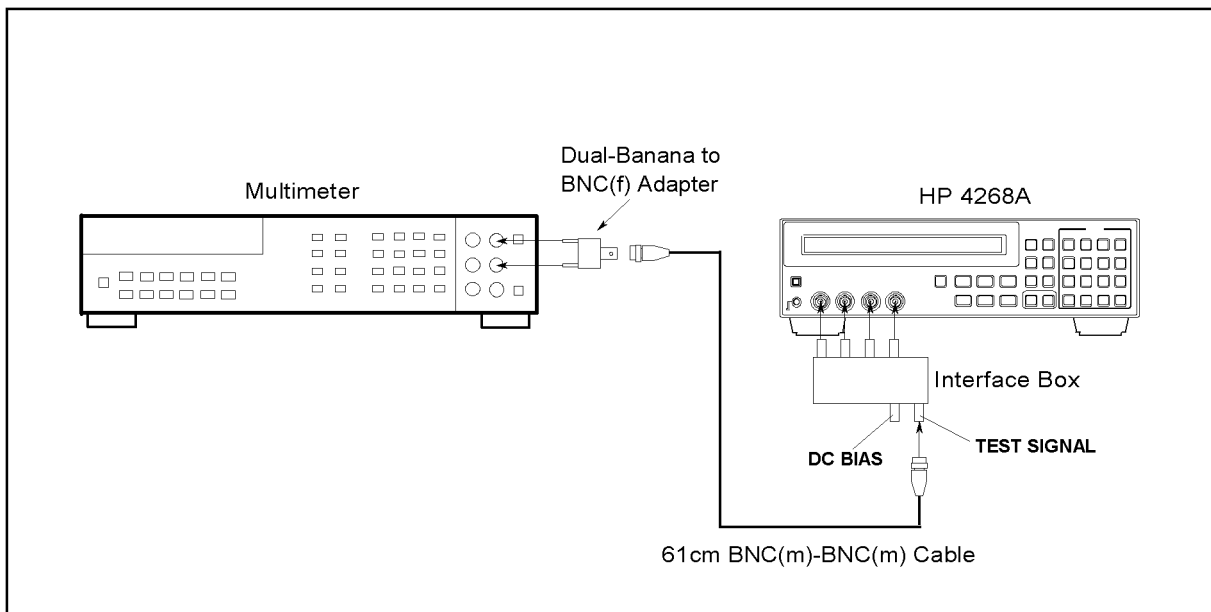

4268ASE02008

Impedance Measurement Adjustment

This adjustment updates the impedance measurement adjustment data stored in the EEPROM.

Equipment

Description	Recommended Model
Standard Resistor Set	42030A
Test Leads, 1m	16048A
Test Leads, 2m	16048D
OPEN Termination	42090A
SHORT Termination	42091A
BNC(f) - BNC(f) Adapter	p/n 1250-0080

Setup

Perform the following steps as the program instructs.

1. Connect the specified equipment as instructed. Refer to the Figure 3-4 and Figure 3-5.
2. Repeat step 1 as instructed.

Figure 3-4 Impedance Measurement Adjustment Setup (without Test Leads)

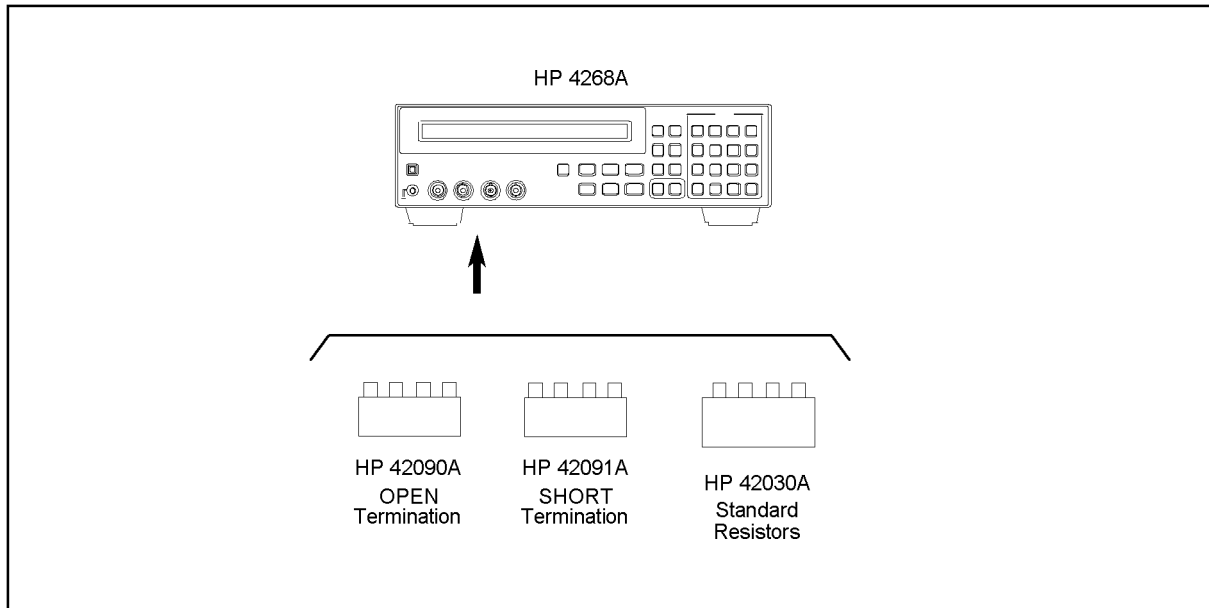
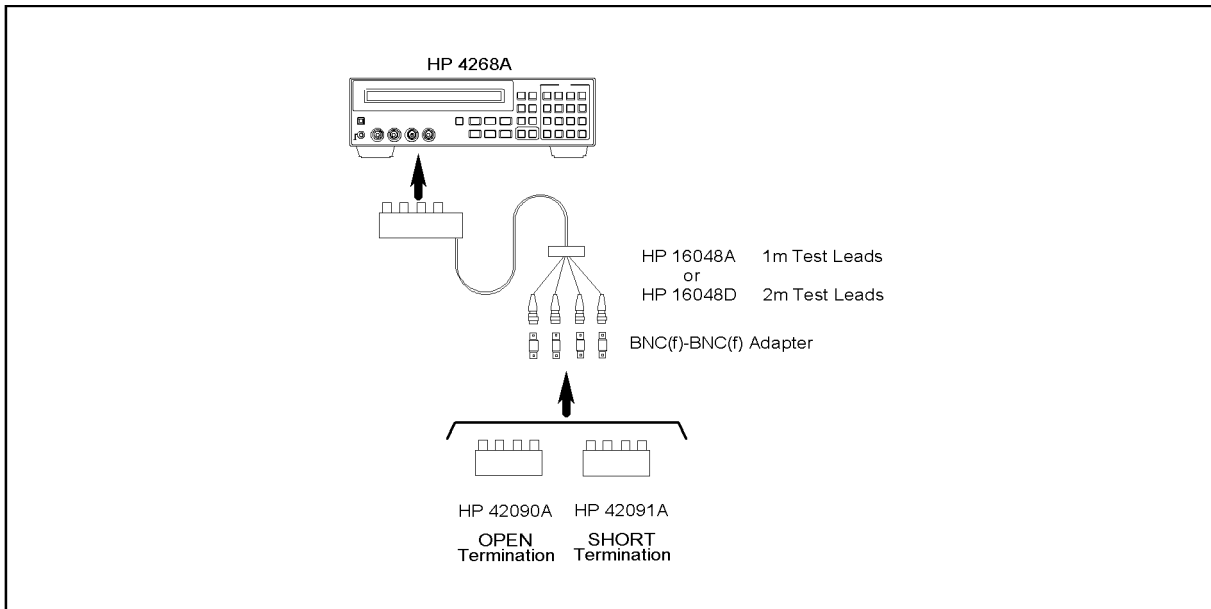

Figure 3-5 Impedance Measurement Adjustment Setup (with Test Leads)



4268ASE03002

Adjustment
Adjustment Procedure Reference

4 Troubleshooting

This chapter provides assembly level troubleshooting information for the 4268A. The information includes trouble isolation, service function, and theory of operation.

Introduction

Safety

Read the safety summary at the front of this manual before servicing the instrument.

WARNING

The servicing procedures described herein are performed when power is supplied to the instrument and its protective covers are removed. This type of servicing must be performed only by service trained personnel who are aware of the hazards involved (for example, fire, and electrical shock). When servicing can be performed without power applied to the instrument, remove power from the instrument. Before any repair is completed, ensure that all safety features are intact and functioning, and that all necessary parts are properly connected to the protective grounding system.

ESD Precautions

When using any of the procedures in this chapter, you should use proper ESD precautions. As a minimum you should place the instrument on a properly grounded ESD mat and wear a properly grounded ESD wrist strap.

Required Equipment

The required equipment is listed on Table on page 11 for troubleshooting.

Trouble Isolation

Overall Troubleshooting

Figure 4-1 shows the overall troubleshooting flowchart to isolate a defect assembly. Follow the flowchart for trouble isolation.

Figure 4-1 Flowchart

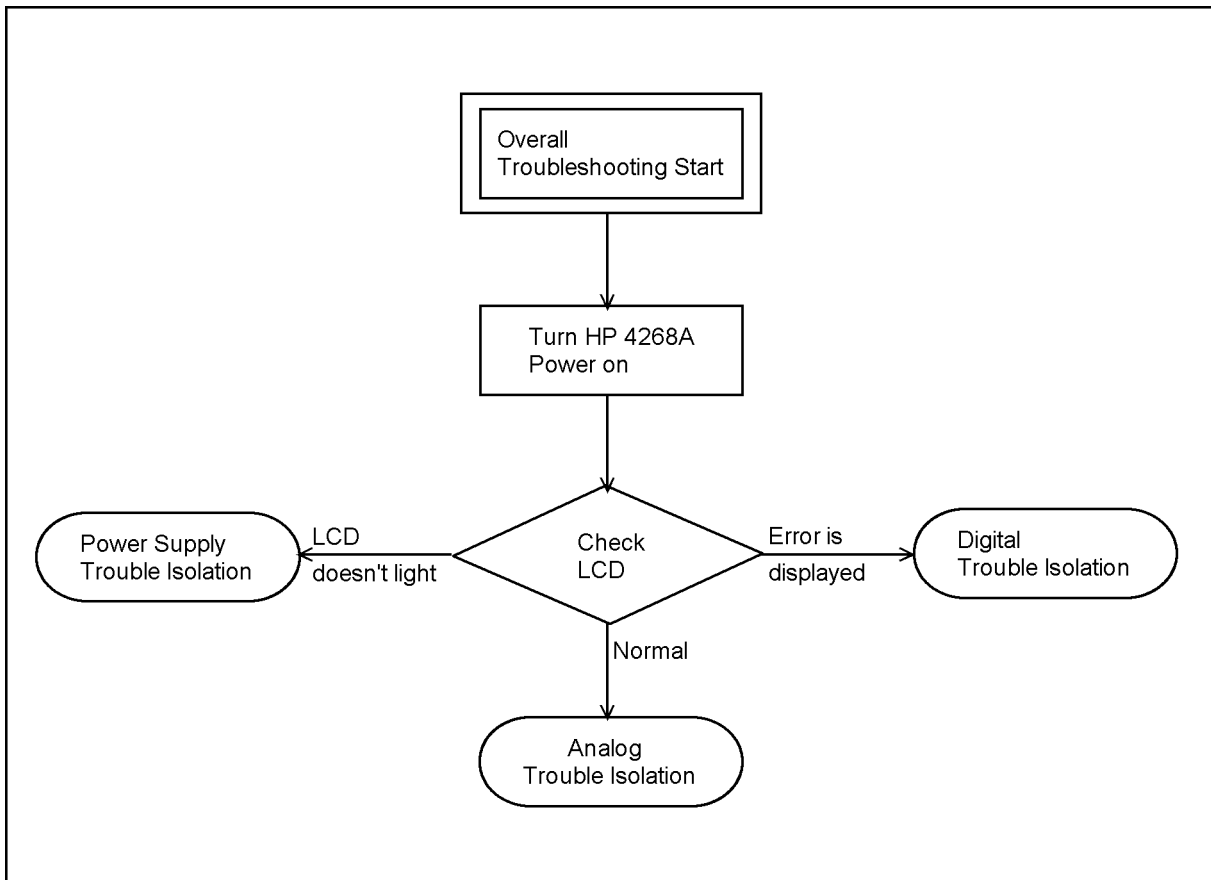

4268ASE05021

Check1 LCD Check

1. Turn the 4268A off, then turn the 4268A on while watching the LCD.
2. Check for a beep sound for a moment and if you see anything is displayed on the LCD.
3. If LCD doesn't light, power supply suppose to be failure. Proceed to "Power Supply Troubleshooting".
4. If error message is displayed on the LCD, power supply seems fine. Proceed to "Digital Circuit Troubleshooting".

5. If no error message is displayed on the LCD, power supply and digital control circuit seem fine. Proceed to “Analog Circuit Troubleshooting”

Power Supply Troubleshooting

Figure 4-2 Flowchart

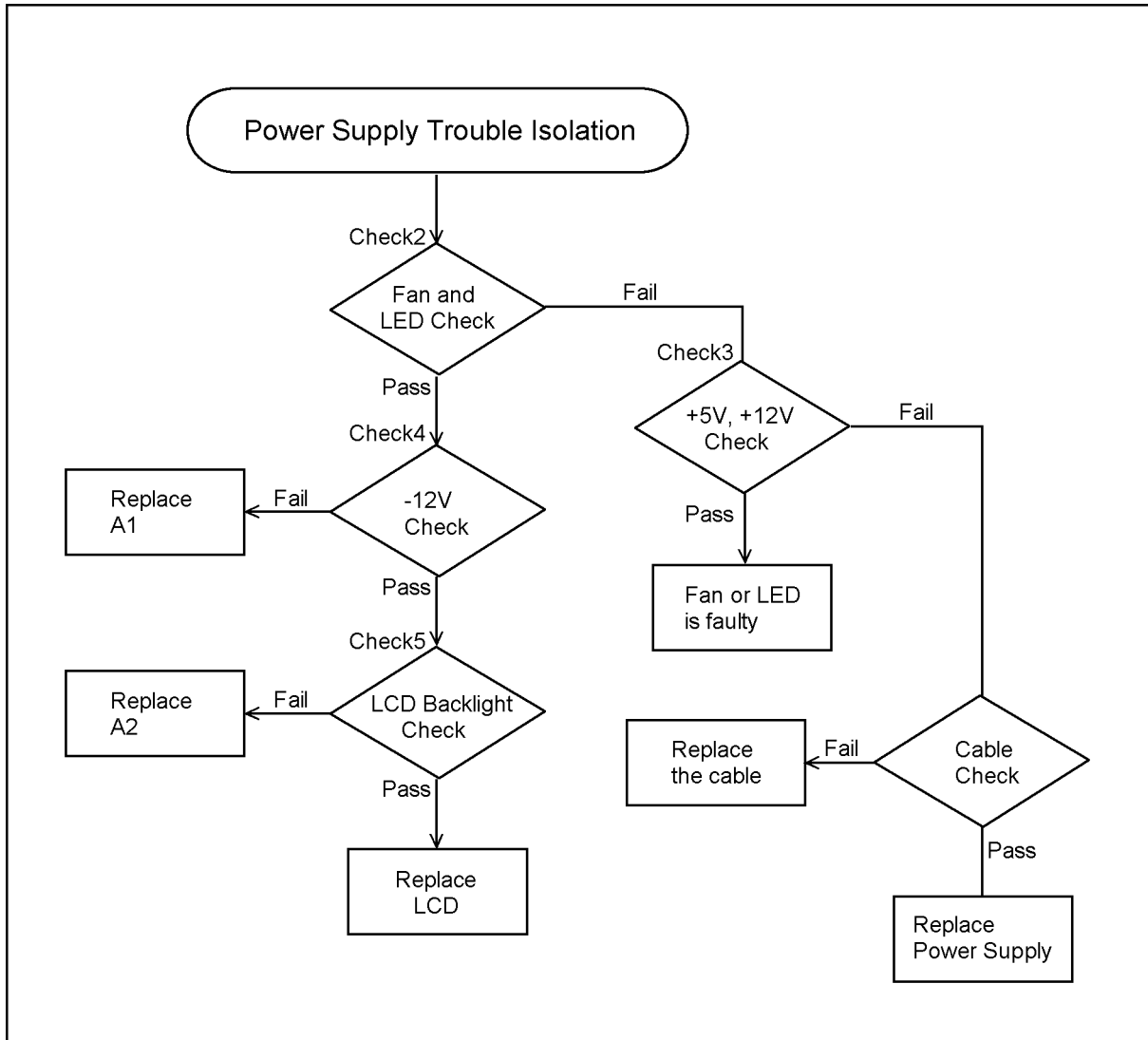

4268ASE05024

Check2 Fan and LED Check

1. Turn the 4268A off.
2. Remove the cover from the 4268A.
3. Turn the 4268A on.
4. Check if the cooling fan is rotating.
5. If fan is rotating, check +12 V LED on A1 board and +5V LED on A2 board.

See Figure 4-3 for the location of the LEDs

6. If fan isn't rotating or LEDs don't light, proceed to "Check3 +5 V and +12 V Check".

Figure 4-3 LEDs location

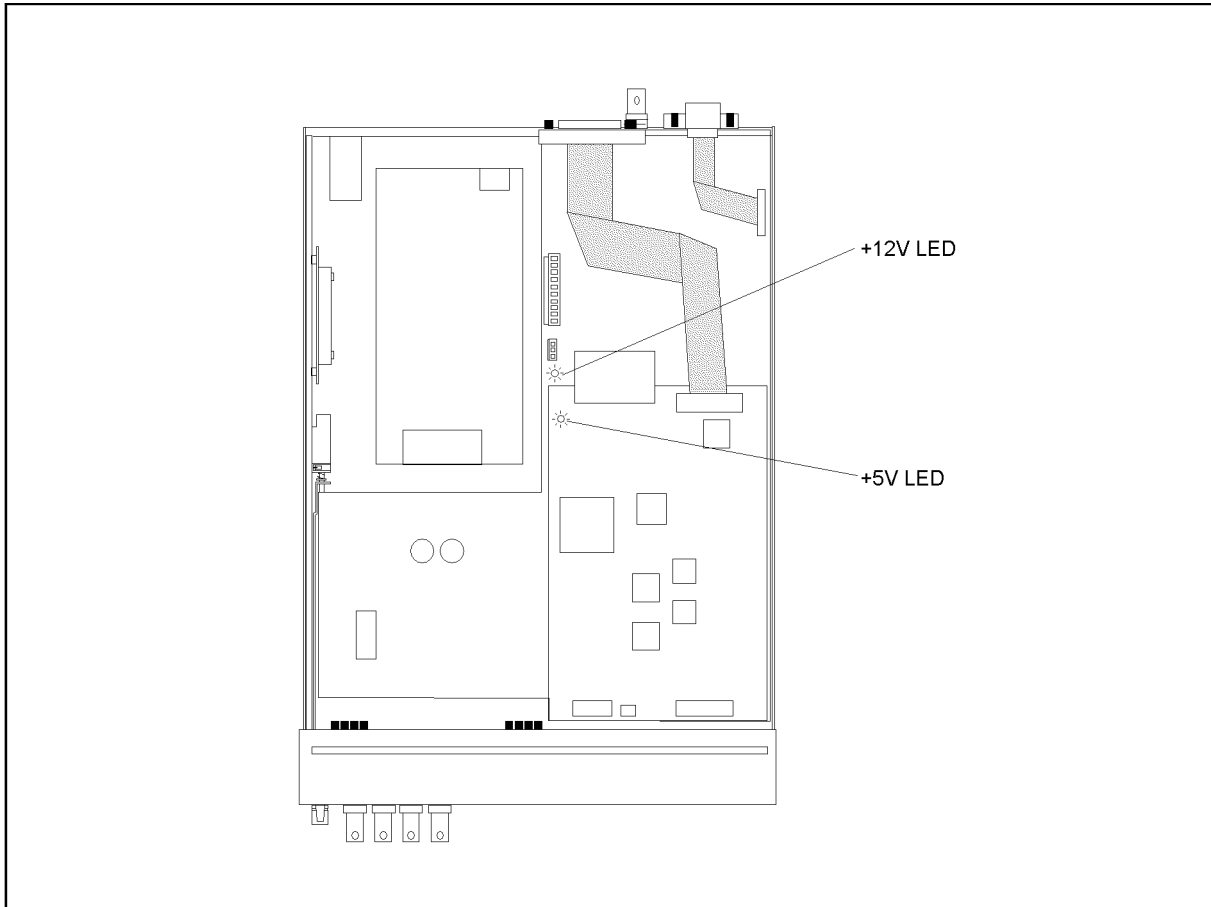

4268ase05028

Check3 +5 V and +12 V Check

1. Turn the 4268A on.
2. When fan doesn't rotate or +12 V LED doesn't light.
 - a. Using a voltmeter, measure the voltage between the +12 V LED and the ground.
 - b. If the voltage is in $+12\text{ V} \pm 0.6\text{ V}$, it's normal. The fan or the LED suppose to be defective.
3. When +5 V LED doesn't light.
 - a. Using a voltmeter, measure the voltage between the +5 V LED and the ground.
 - b. If the voltage is in $+5\text{ V} \pm 0.5\text{V}$, it's normal. The LED supposes to be

defective.

4. The +5 V or +12 V voltage isn't normal, power supply assembly or cable assembly between A1 and power supply seems defective. Isolate them by checking the cable is broken or not using a tester.

Check4 -12V Check

1. Turn the 4268A on.
2. Using a voltmeter, check the center pin of the U117 regulator. If the voltage is $-12\text{ V} \pm 0.6\text{ V}$, it's normal. Proceed to "Check5 LCD Backlight Check".
3. If the voltage is not normal, power supply assembly or cable between A1 and power supply assembly suppose to be defective.
4. If the cable isn't defective, replace the power supply assembly.

Check5 LCD Backlight Check

1. Turn the 4268A on.
2. Remove a cable connected to LCD backlight from A2 board.
3. Measure voltage of the socket using a multimeter.
4. If the voltage is not $+5\text{ V} \pm 0.5\text{V}$, replace A2 board.
5. If the voltage is $+5\text{ V} \pm 0.5\text{V}$, replace LCD.

Digital Circuit Troubleshooting

Figure 4-4 Flowchart

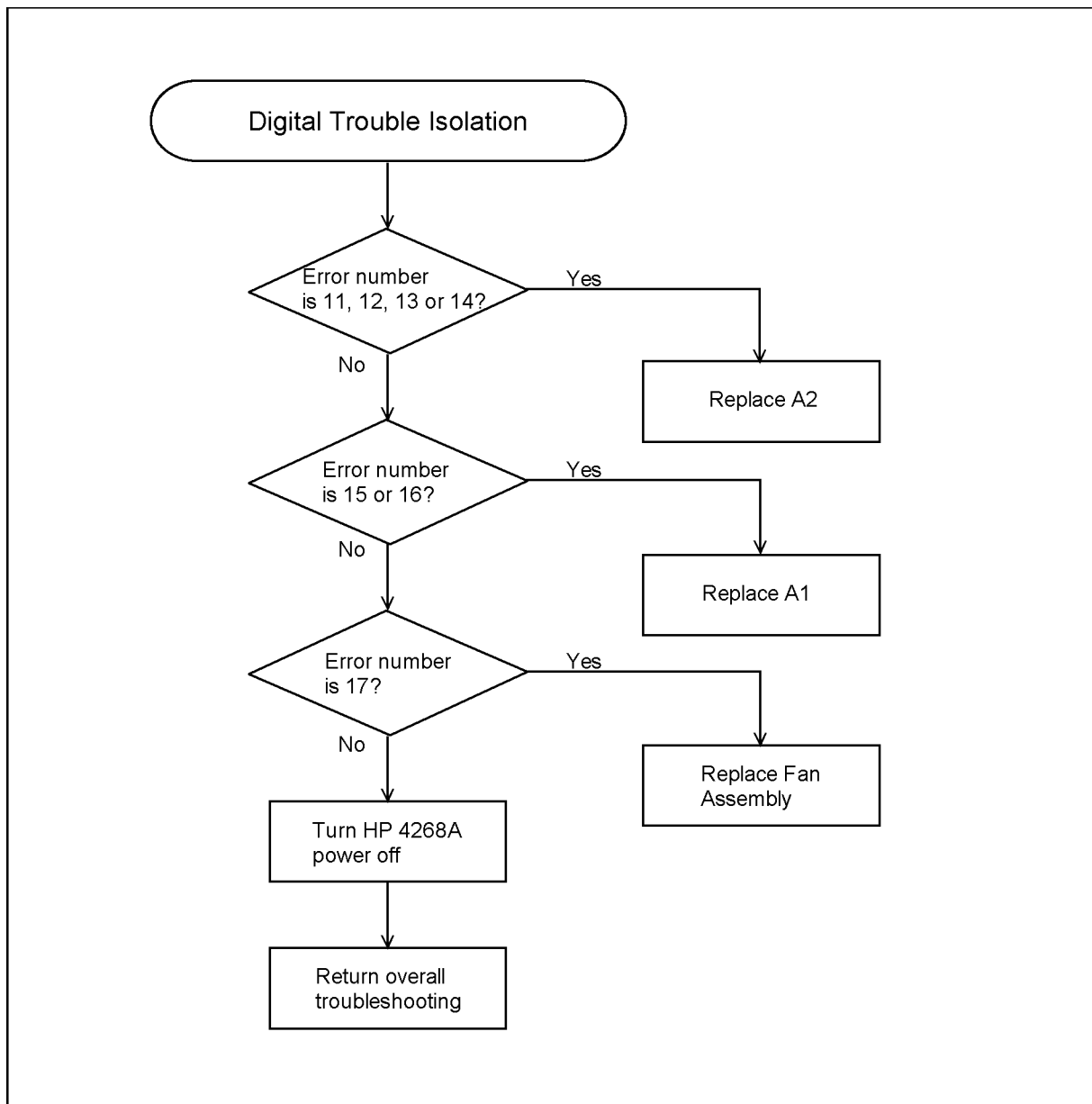

4268ASE05023

Check6 Error Number Confirmation

1. If error number is 11, 12, 13, or 14, replace A2 assembly
2. If error number is 15 or 16, replace A1 assembly
3. If error number is 17, replace fan assembly
4. Turn the 4268A off.

Troubleshooting
Trouble Isolation

5. Go to “Overall Troubleshooting” on page 69.

Analog Circuit Troubleshooting

Figure 4-5 Flowchart

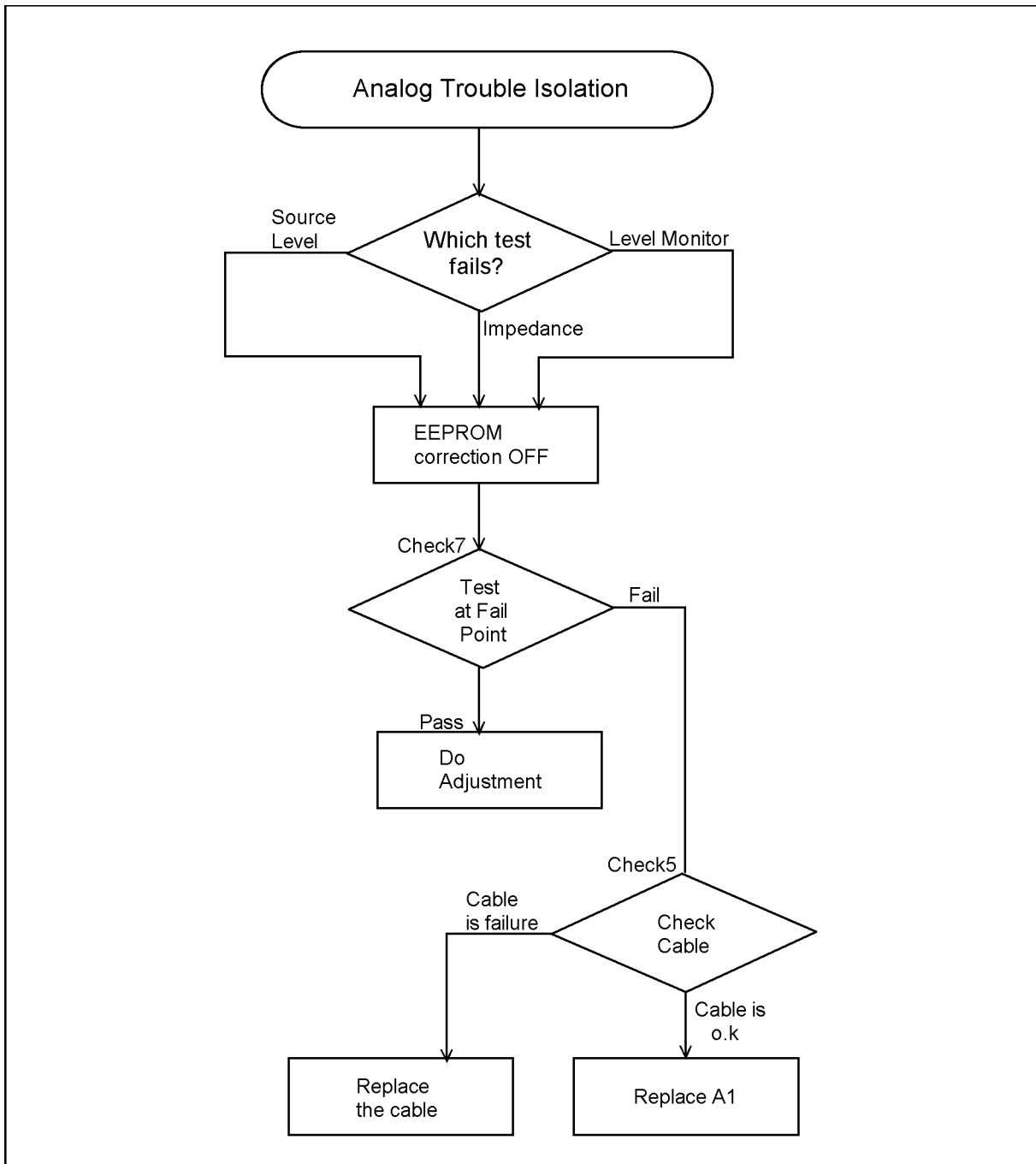

4268ASE05022

Check7 Test at failed point

1. Set the 4268A adjustment data setting Off to cancel the digital adjustment. See “Adjustment Data Setting” on page 83.

Troubleshooting
Trouble Isolation

2. Test the 4268A manually at the failed test point. See Chapter 2 ,
“Maintenance.”
3. If the test result is within the limit for raw analog circuit, the adjustment data in EEPROM suppose to be defective. Perform the adjustment. The rough limits are followings.
 - Signal Level: $\pm 15\%$ of 4268A setting
 - Level Monitor $\pm 10\%$ of 4268A reading
 - Impedance Measurement $\pm 10\%$ of 4268A reading after open/short correction.
4. If the test result is out of the limit, A1 or cables between A1 and front panel's BNC connector suppose to be defective.
5. If all cables are normal, replace A1 assembly.

Service Function

The service functions are used to test, verify, control, and troubleshoot

Firmware Revision Confirmation

- Turn the 4268A off then turn it on again. (Immediately after turning the power on, the firmware version and option information appear on the display.)
- Press the **Config** key (blue key, - key), use the $\uparrow \rightarrow$ key to blink Rev, and then press the **Enter** key.

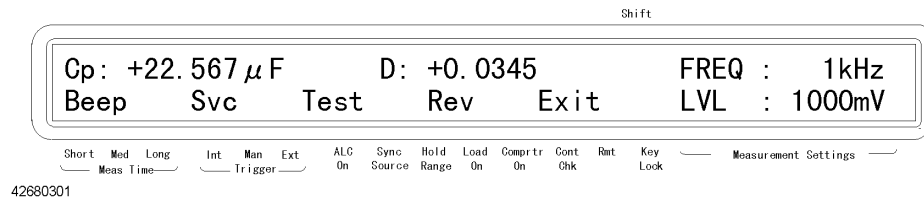

Self Test

The 4268A provides a self-test function. The self-test performs brief checks of the operation of digital parts including memory.

Step 1. Press the **Config** key (blue key, - key). The menu as shown below appears.

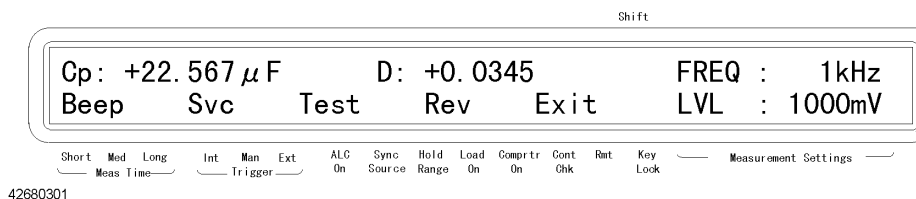

Step 2. Use the \uparrow key to blink Test and then press the **Enter** key. The “SELF TESTING” message appears and the self-test is executed.

Step 3. When the test is completed, SELF TEST:PASS is displayed for approximately 1 second (if an error occurs, its error number is displayed. For details on displayed error number, refer to Table 4-1) and then the menu in Step 1 appears. Check that Exit is blinking (if not, operate keys to blink Exit) and then press the **Enter** key to exit from the menu.

NOTE

If several errors are detected at one time, the sum of their error numbers is displayed.

Table 4-1

Self-test Items

Test item	Test description	Error code
RAM	Verifies that the RAM data bus is connected correctly and there is no faulty memory cell.	1
Boot ROM	Verifies that the checksum of Boot ROM is correct.	2
Flash ROM	Verifies that the checksum of Flash ROM is correct.	4
Calibration data	Verifies that the checksum of the adjustment data in the EEPROM is correct.	8
User correction data	Verifies that the checksum of the OPEN/SHORT/LOAD correction data in the EEPROM is correct. Even if the test fails, the correction data is not initialized.	16
A1 main board	Verifies that the board ID of the A1 main board (analog board) is correct and that the A/D converter operates normally.	32
Backup RAM	Verifies that the instrument setting value in the backup memory (RAM) is correct. Even if the test fails, the instrument setting value is not initialized.	64

Power On Self-test

This test is executed when the 4268A is turned on. This test performs the following brief checks of the operation including memory. This test is executed at power-on.

- RAM test failed
The RAM data bus or the address bus is NOT connected correctly. Replace A2 assembly.
- Boot ROM test failed
The BOOT ROM check sum is invalid. If only the Boot ROM is failed, replace the BOOT ROM. If other test failed, replace A2 assembly.
- Flash ROM test failed
The Flash ROM check sum is invalid. Install firmware to the Flash ROM. If 4268A still fails, replace A2 assembly.
- EEPROM test failed
Read/Writing EEPROM is not performing correctly. If only the EEPROM test failed, replace EEPROM and perform the adjustment. If other test failed, replace A2 assembly.
- A1 board test failed
The A1 board's ID is incorrect or the A/D converter is not working properly. Replace A1 assembly.
- Calibration memory lost
The Factory Calibration Data in the EEPROM has been lost. Perform the adjustment.
- User data lost
The User Correction Data in the EEPROM has been lost. The correction data is initialized to the factory setting.
- Previous setting lost
The instrument setting values in the backup memory have been lost. These value is initialized to the factory setting. Possible causes include a lapse of 72 hours after power-off.

Front Panel Key Test

Follow these steps to test the function of a front panel key.

- Step 1.** Press the **Config** key (blue key, - key). Use the $\uparrow\rightarrow$ key to blink Svc and then press the **Enter** key. The service function menu below appears.

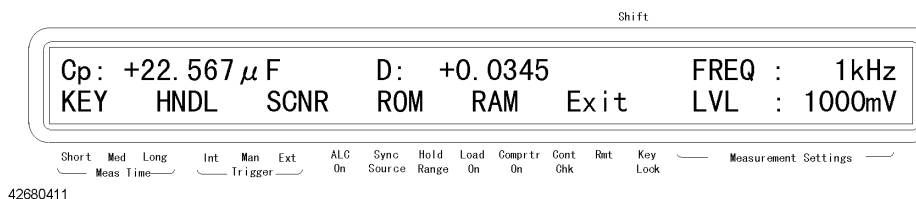

- Step 2.** Use the $\uparrow\rightarrow$ key to blink KEY and then press the **Enter** key. The front panel key test screen appears.
- Step 3.** Press a key you want to test. The name of the pressed key is displayed next to KEY TEST: in the upper line of the display. The following figure shows an example when the **Trig** key is pressed. If the name of the key is not displayed correctly, the key does not function. Contact your nearest Agilent Technologies sales office or the company from which you purchased this instrument.

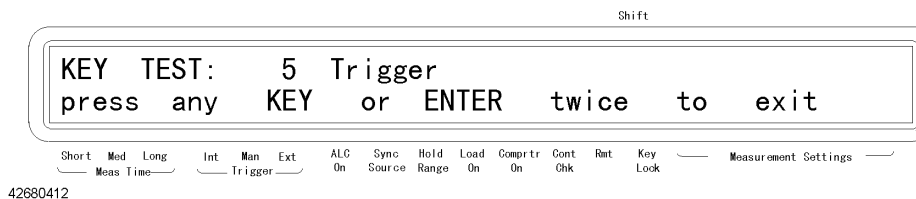

- Step 4.** If you want to finish the test, press the **Enter** key twice. The service function menu appears. Check that Exit is blinking (if not, operate keys to blink Exit), press the **Enter** key to return to the immediately previous menu, and then exit from this menu in the same way.

Handler Interface Test

Verify the Handler Interface Function using the handler interface simulator. For detail, refer to Handler Interface functional test in “Handler Interface Test” on page 37.

Scanner Interface Test (Opt. 001 only)

Verify the Scanner Interface Function using the scanner interface simulator. For detail, refer to Scanner Interface functional test in “Scanner Interface Test (opt. 001 only)” on page 41.

ROM Test

Verifies that the checksum of the Boot ROM and the Flash ROM are correct.

- Step 1.** Press the **Config** key (blue key, - key). Use the $\uparrow\rightarrow$ key to blink Svc and then press the **Enter** key. The service function menu below appears.

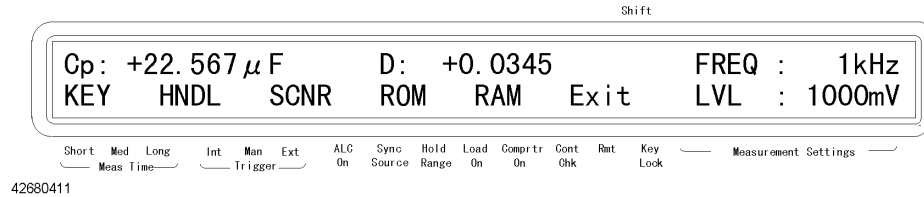

- Step 2.** Use the $\uparrow\rightarrow$ key to blink ROM and then press the **Enter** key. The front panel key test screen appears.
- Step 3.** Pass or Fail is displayed next to BOOT TEST: and FLASH TEST: in the upper line of the display. The following figure shows an example when this test is completed.

RAM Test

Verifies that the RAM data bus is connected correctly and there is no faulty memory cell.

- Step 1.** Press the **Config** key (blue key, - key). Use the $\uparrow\rightarrow$ key to blink Svc and then press the **Enter** key. The service function menu below appears.

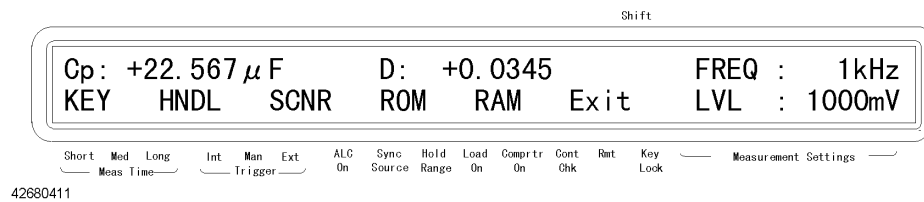

- Step 2.** Use the $\uparrow\rightarrow$ key to blink RAM and then press the **Enter** key. The front panel key test screen appears.
- Step 3.** Pass or Fail is displayed next to RAM TEST: in the upper line of the display. The following figure shows an example when this test is completed.

EEPROM Test

Verifies that the EEPROM data bus is connected correctly and there is no faulty memory cell.

Step 1. Turn the 4268A off. Then while pressing the ←↓ key, turn the 4268A on.

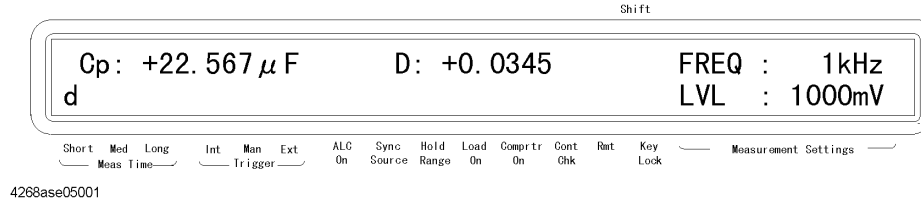

Step 2. Press the **Config** key (blue key, - key). Use the ↑→ key to blink Svc and then press the **Enter** key.

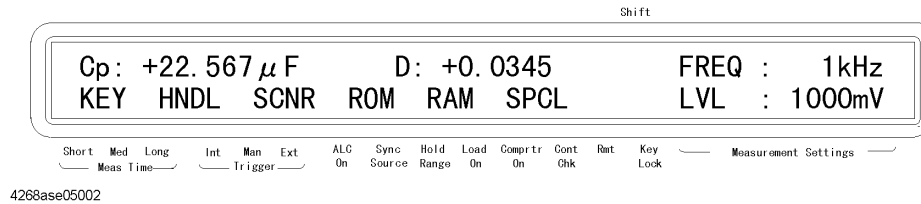

Step 3. Confirm that SPCL is blinking, and then press the **Enter** key.

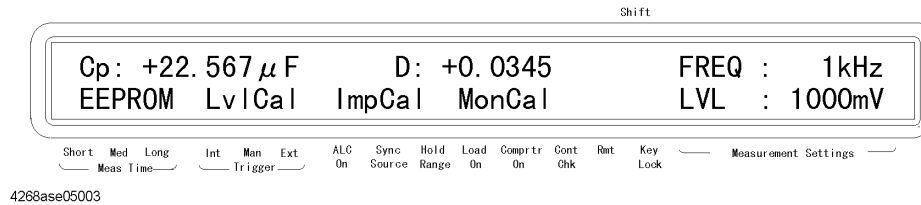

Step 4. Confirm that EEPROM is blinking, and then press the **Enter** key.

Step 5. PASS or FAIL is displayed next to EEPROM TEST: in the upper line of the display. To return the upper menu, press the Cancel key (blue key, **BkSp** key)

Adjustment Data Setting

Set the adjustment data status in EEPROM to activated or not.

Step 1. Turn the 4268A off. Then while pressing the ←↓ key, turn the 4268A on.

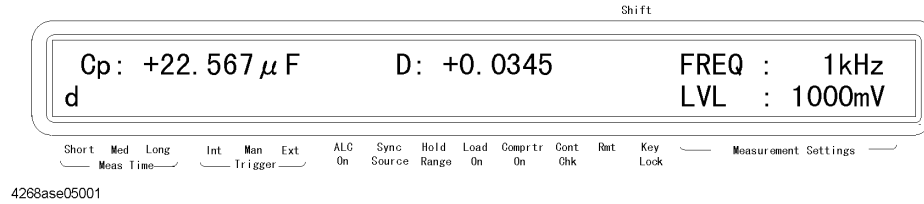

Step 2. Press the **Config** key (blue key, - key). Use the ↑→ key to blink Svc and then press the **Enter** key.

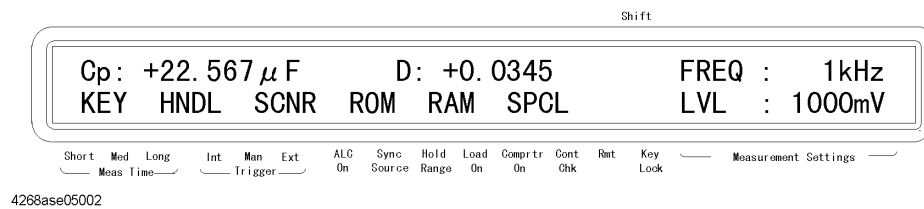

Step 3. Confirm that SPCL is blinking, and then press the **Enter** key.

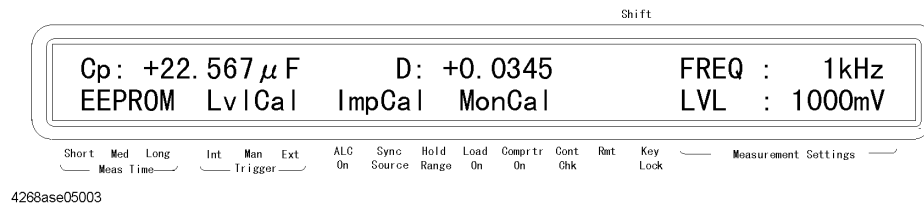

Step 4. To select proper adjustment data, use the ←↓ key or the ↑→ key to blink LvlCal, ImpCal, or MonCal and then press the **Enter** key.

Step 5. Select On or Off using the ←↓ key or the ↑→ key, then press the **Enter** key.

- On: Adjustment data in EEPROM is used for the 4268A measurement. (Default)
- Off: Adjustment data in EEPROM is canceled temporary. Raw analog characteristic of the 4268A will behave.

Theory of Operation

This section describes the general overall operation of the 4268A and the operation of each assembly.

Overall Measurement Theory

The 4268A measures the impedance of the Device Under Test (DUT) by measuring vector voltage to current ratio. A vector is a value which consists of a magnitude and a phase. The impedance of the DUT is determined by the vector ratio between the voltage across the DUT and the current flowing through it. The 4268A essentially consists of a signal source, a vector voltmeter, and a vector current meter.

Figure 4-6 Measurement Principal

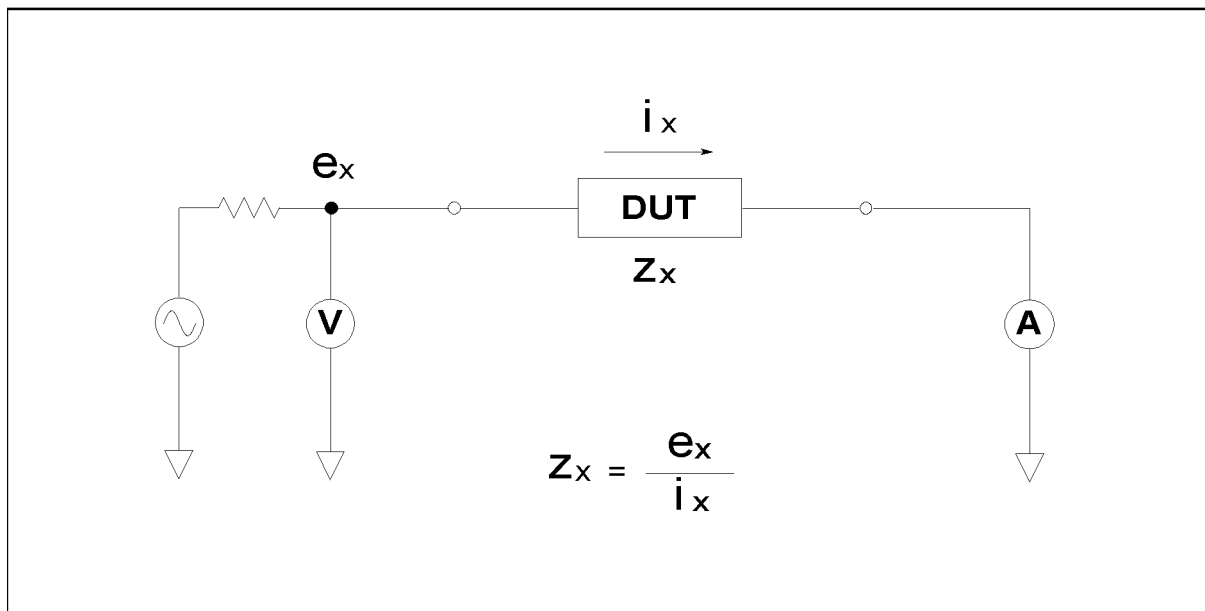

4268ASE05025

In Figure 4-6, a DUT connected in series with a test voltage source (including an output resistance), voltmeter V, and ammeter, A. If the ammeter measures i_x ampere when the source voltage is e_x , the DUT's impedance Z_x is expressed by:

$$Z_x = e_x / i_x$$

Analog Circuit

The analog circuit of the 4268A consists of signal source section, transducer section, and detector section. The signal source section applies a measurement signal to the DUT. The transducer block converts the voltage across and the current through the DUT to two voltages which are output to the vector ratio

detector. The voltage across the DUT is input to differential amplifier, v . The current through the DUT is converted to a voltage before being input to differential amplifier, i . The vector ratio detector switches these two voltages to be converted to digital data. The CPU calculates DUT impedance from the vector ratio of these two voltages and displays the result on the LCD.

Figure 4-7 Analog Circuit Block Diagram

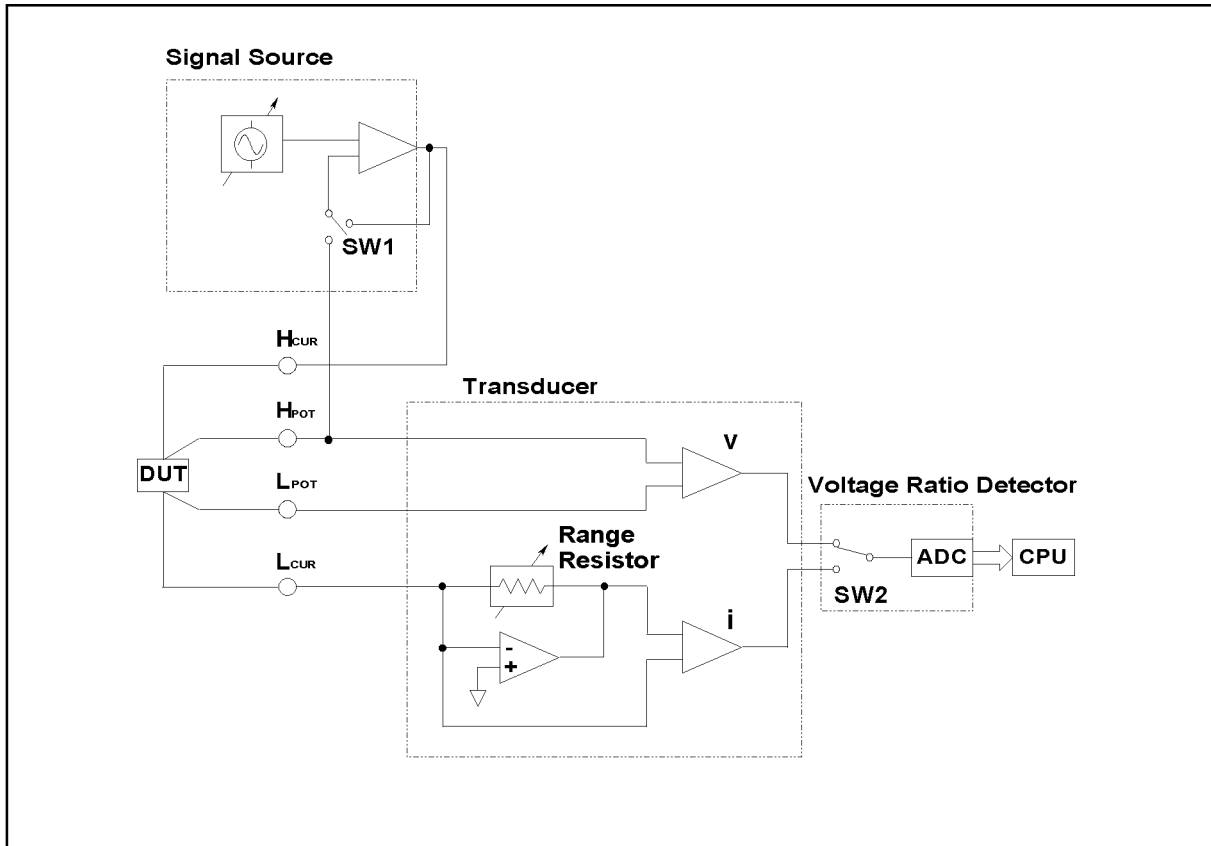

4268ASE05011

The signal source generates an ac signal of which frequency and level is set from the front panel or by GPIB commands. The signal is applied to the DUT via the High-Current (Hcur) connector. The current flowing through the DUT is current sunk into the Low-Current (Lcur) connector, which serves as virtual ground.

The vector voltage across the DUT is detected by the voltage between High-Potential (Hpot) and Low-Potential (Lpot) connectors. The vector current flowing through the DUT is detected by converting the current flowing into Lcur connector to a corresponding voltage, using an I-V converter.

One of the two outputs from the transducer is selected in the vector ratio detector by switch SW2. The selected signal is processed according to measurement conditions, such as measurement time and measurement range, and is converted into digital data by the Analog-to-Digital Converter (ADC)

Signal Source

The signal source section generates ac signal. The signal frequency can be selected from 120 Hz and 1 kHz. The signal level can be set from 100 mV to 1000 mV by 10 mV step.

The auto level control (ALC) function is designed to apply the voltage to the DUT correctly. When DUT has very low impedance, the applied voltage might decrease due to the output resistance of the voltage source and the resistance of the measurement cable.

Figure 4-8 Signal Source Block Diagram

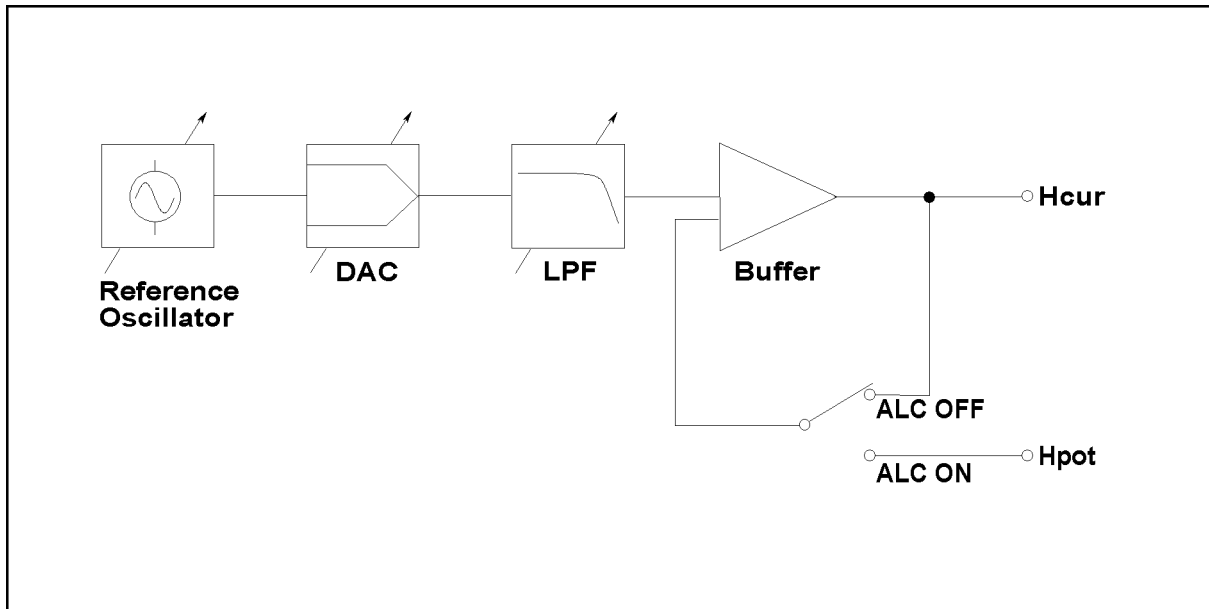

4268ASE05013

Transducer

The transducer section measures the vector voltage across the DUT, and the current flowing through the DUT by converting the current to voltage. Figure 4-9 shows the transducer block diagram.

The voltage across the DUT is measured at the Hpot and Lpot connectors using a differential amplifier. The current flowing through the DUT and flowing into the Lcur connector is converted to voltage by an I-V converter. The differential amplifier measures the voltage between an I-V converter output and the inverting input of the converter. The inverting input of the converter, thus Lc, is at virtual ground, because of the very high input impedance and very high open loop gain of the operational amplifier used in the I-V converter.

The R1 is called range resistor. The 4268A selects one of range resistors. 100 μ F range at 1 kHz and 1 mF range at 120 Hz are switched using a mechanical relay.

Figure 4-9 Transducer Block Diagram

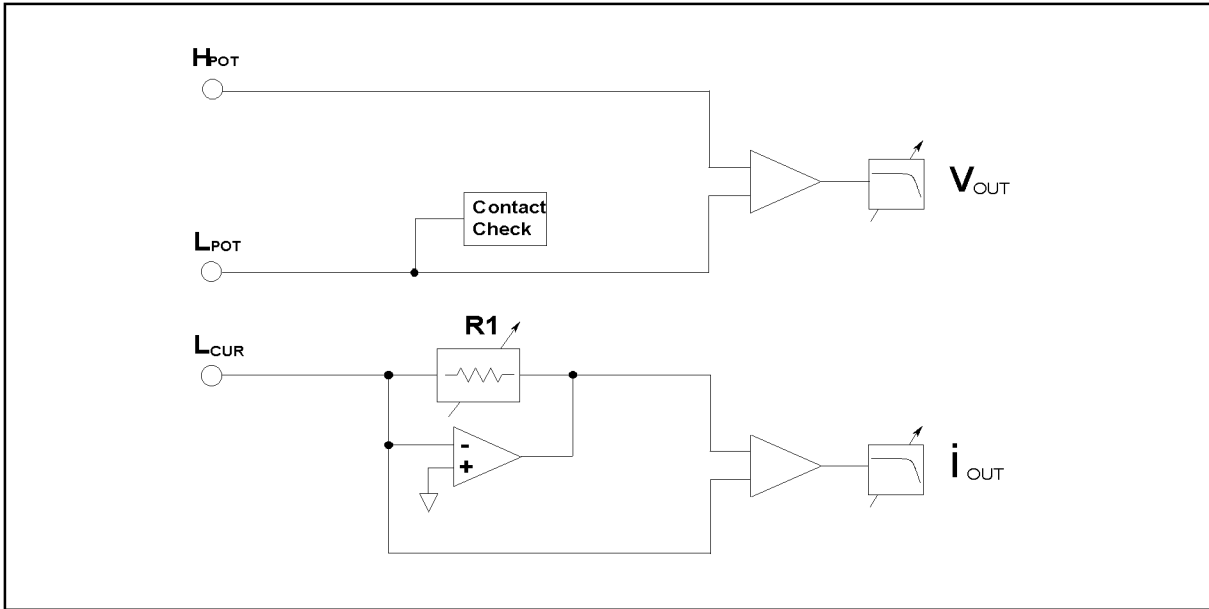

4268ASE05026

Detector

The vector ratio detector section processes the two output voltages from the transducer section and converts these voltages into digital data. Figure 4-10 shows the vector ratio detector block diagram. In the figure, i_{OUT} and v_{OUT} are the outputs of the transducer section.

The amplifier amplifies the ac signal. Its gain depends on the signal source voltage and measurement range.

Low pass filter (LPF) filters the signal so that noises of higher frequency than the measurement signal frequency is cut. The filter cutoff frequency depends on the measurement signal frequency

Figure 4-10 Detector Block Diagram

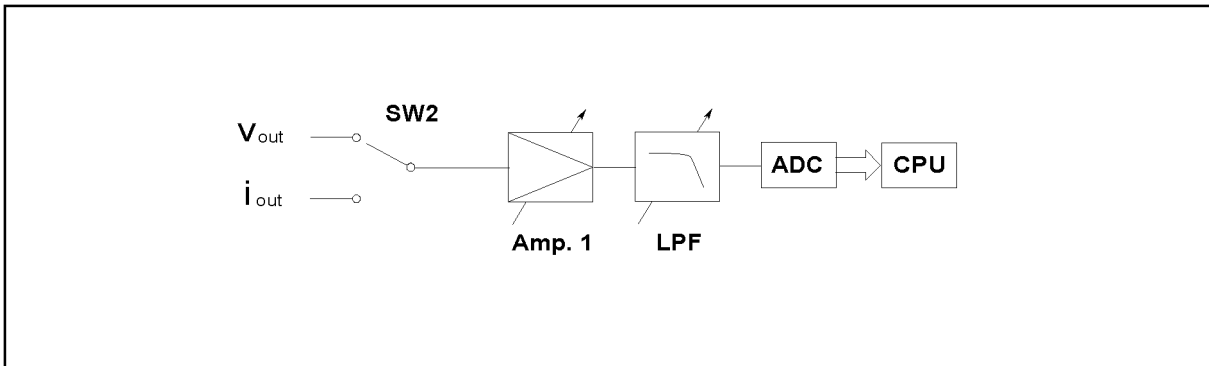

4268ASE05027

4. Troubleshooting

Digital Circuit

The digital circuit consists of the A2 CPU board assembly and peripheral assemblies such as the keyboard and LCD. The circuit communicates with the A1 main board assembly in order to control the latches, switches, and other components on the A1 assembly and receive the measurement data. The GPIB interface on the A2 assembly allows the 4268A communicate with a controller. A handler interface on the A1 assembly allows the 4268A communicate with an external handler.

The A2 CPU board assembly includes a processor, Boot ROM, Flash ROM, EEPROM, and LEDs. The Boot ROM stores the booting program. The Flash ROM stores the firmware which controls the 4268A's operation and functions. The firmware can be updated using a updating program written using the HTBasic.

The EEPROM stores the unit unique data, such as the adjustment data and the operator unique data, such as the operator saved measurement setup condition. The EEPROM will not lose its data when power is turned off. The EEPROM is mounted in a socket for easy replacement.

Figure 4-11 Digital Circuit

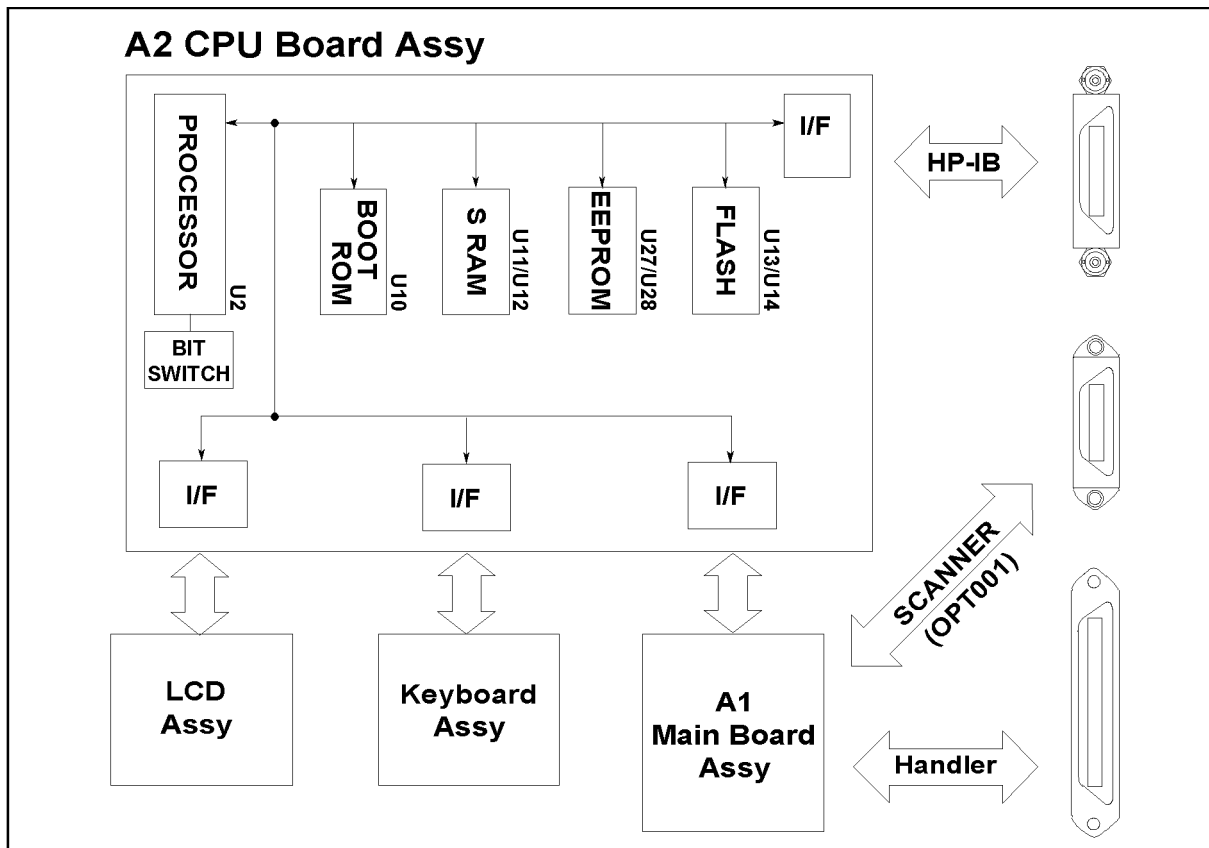

4268A SE05012

Power Supply Circuit

The ac line power is connected to the AC Inlet on the rear panel, that includes the fuse. And the ac line power is supplied to power supply assembly.

The power supply assembly outputs dc voltages of +12 V, +5 V, and - 12V. The dc voltages are supplied to all assemblies, either directly or indirectly via the A1 assembly.

5 **Assembly Replacement**

This chapter contains the 4268A's replaceable parts list and the procedure to replace its assemblies.

Safety

Read the safety summary at the front of this manual before servicing the instrument.

WARNING

The servicing procedures described herein are performed when power is supplied to the instrument and its protective covers are removed. This type of servicing must be performed only by service trained personnel who are aware of the hazards involved (for example, fire, and electrical shock). When servicing can be performed without power applied to the instrument, remove power from the instrument. Before any repair is completed, ensure that all safety features are intact and functioning, and that all necessary parts are properly connected to the protective grounding system.

ESD Precautions

When using any of the procedures in this chapter, you should use proper ESD precautions. As a minimum you should place the instrument on a properly grounded ESD mat and wear a properly grounded ESD wrist strap.

Replaceable Parts List

Ordering Information

To order part listed in the replaceable part lists, quote the Agilent Technologies part number (with a check digit), indicate the quantity required, and address the order to the nearest Agilent Technologies office. The check digit will ensure accurate and timely processing of the order.

To order a part not listed in the replaceable part table, include the instrument model number, the description and function of the part, and the quantity of parts required. Address the order to the nearest Agilent Technologies office.

Exchange Assemblies

Under the rebuilt-exchange assembly program, certain factory-repaired and tested assemblies are available on a trade-in basis. These assemblies are offered at lower cost than a new assembly, but meet all factory specifications required of a new assembly.

The defective assembly must be returned for credit under the terms of the rebuilt-exchange assembly program. Any spare assembly stock desired should be ordered using the new assembly part number.

Parts List

Figure 5-1 **Top View, Major Assembly**

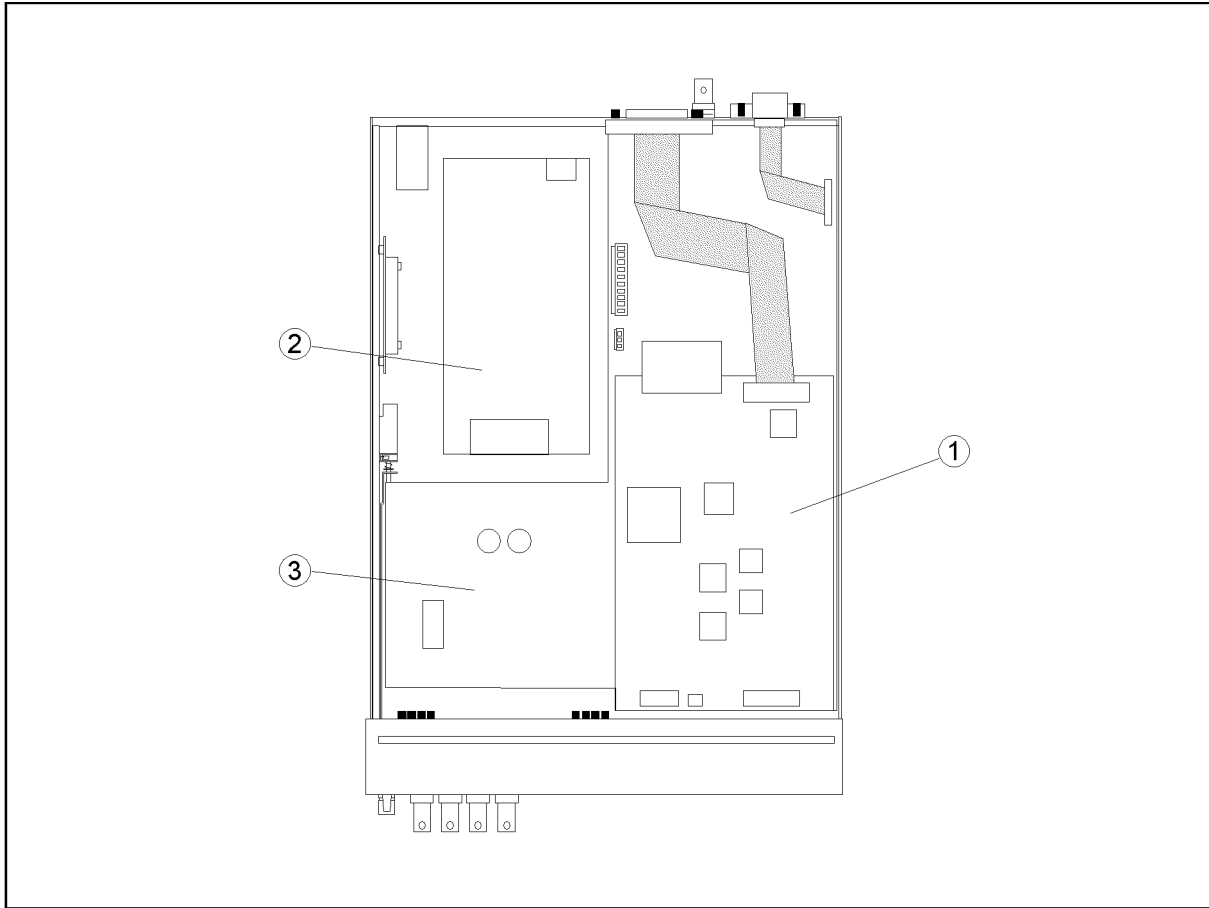

4268ase07001

Table 5-1 **Top View, Major Assembly**

Reference Designation	Agilent Part Number	Check Digit	Qty.	Description
1	04268-66502	1	1	A2 CPU Board Assembly
	04339-24006	8	4	Standoff
	0515-1550	0	4	Screw M3
2	04268-04001	5	1	Shield
	04268-01202	2	1	Bottom Cover
	0950-3408	3	1	Power Supply 50 W
	1400-1048	9	1	Saddle Edge
	0515-1550	0	8	Screw M3
	3	04268-66501	0	1
04268-69501				A1 Analog Board Assembly (Exchange)
0515-1550		0	8	Screw M3

Figure 5-2 Top View, Cable

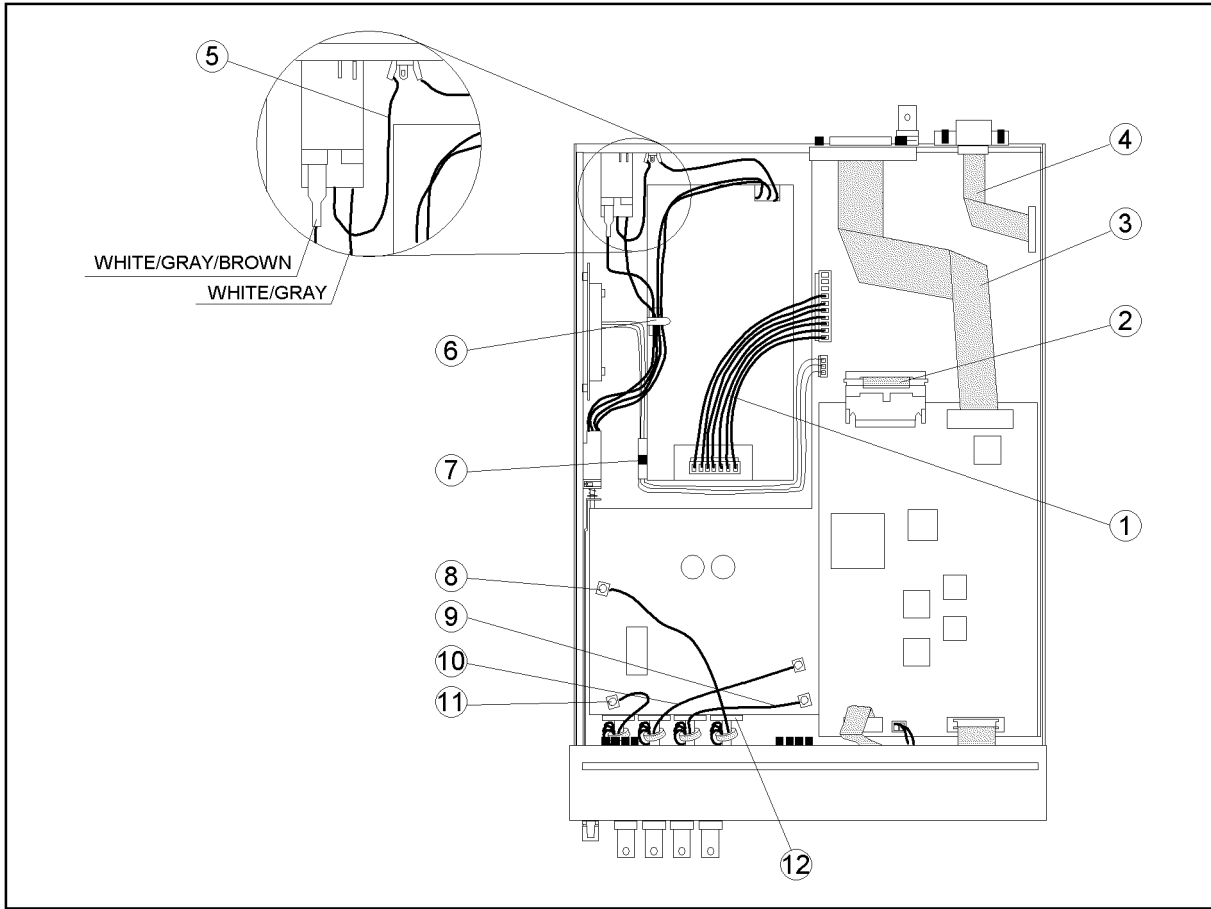

4268ase07002

Assembly Replacement
Replaceable Parts List

Table 5-2 **Top View, Cable**

Reference Designation	Agilent Part Number	Check Digit	Qty.	Description
1	04268-61632	8	1	Wire Assembly
2	Part of A1 Board			Flat Cable
3	04194-61697	6	1	Flat Cable Assembly
4	See Table 5-9			Cable Assembly (Opt.001)
5	04268-61633	9	1	Wire Assembly (for ground)
6	1400-1391	5	1	Cable Clamp
7	1400-1334	6	1	Cable Clamp
8	04268-61601	1	1	RF Cable Assembly "A"
9	04268-61602	2	1	RF Cable Assembly "B"
10	04268-61603	3	1	RF Cable Assembly "C"
11	04268-61604	4	1	RF Cable Assembly "D"
12	04339-25004	8	4	Core Clamp
	0515-1551	1	4	Screw M3

Figure 5-3 Top View, Mechanical Parts

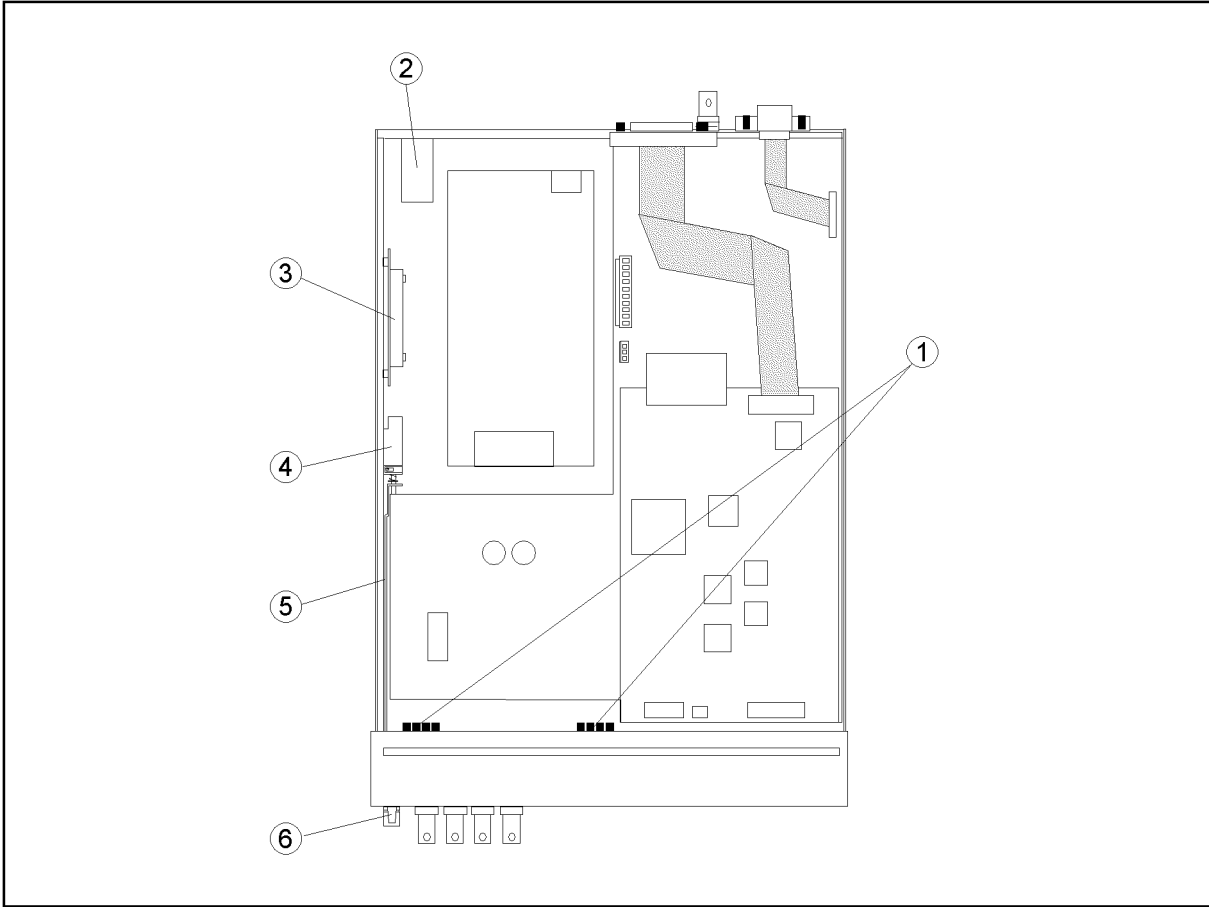

4268ase07003

Assembly Replacement
Replaceable Parts List

Table 5-3 **Top View, Mechanical Parts**

Reference Designation	Agilent Part Number	Check Digit	Qty.	Description
1	04263-07001	6	2	Gasket
	0515-1550	0	4	Screw
2	1252-6951	8	1	AC Inlet
	2110-0381	7	1	Fuse 3A 250V
	2110-1134	0	1	Fuse Drawer
3	04268-61621	5	1	Fan Assembly
	04268-00603	5	1	Plate
	3050-0891	7	4	Washer (flat type)
	2190-0584	0	4	Washer (lock type)
	0515-0986	4	4	Screw M3 (with a pan head)
	0515-1005	0	4	Screw M3 (with a flat head)
4	04268-61634	0	1	Wire assembly (Line Switch)
	0515-0914	8	2	Screw M3
5	04268-01203	8	1	Angle (Line Switch)
	04339-25002	6	2	Guide
	0515-0914	8	2	Screw M3
6	0370-2862	1	1	Button
	04339-23001	1	1	Shaft
	0535-0031	2	1	Nut

Figure 5-4 Bottom View

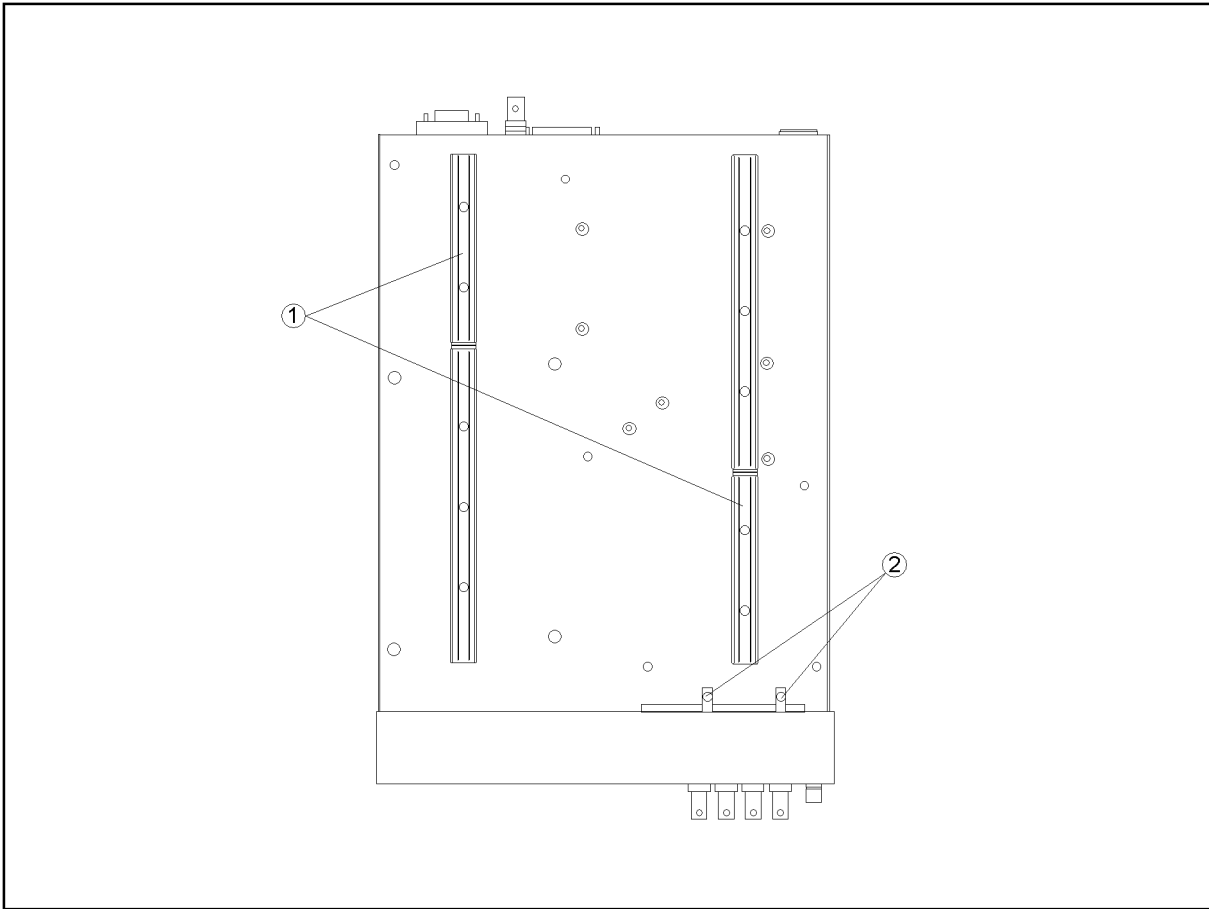

4268ase07004

Table 5-4 Bottom View

Reference Designation	Agilent Part Number	Check Digit	Qty.	Description
1	5040-3347	5	2	Plate
	0460-0616	0	35 cm × 2	Adhesive Tape
2	0515-1550	0	2	Screw M3-L 8 P-H

Assembly Replacement
Replaceable Parts List

Figure 5-5 4268A Front Assembly 1/4

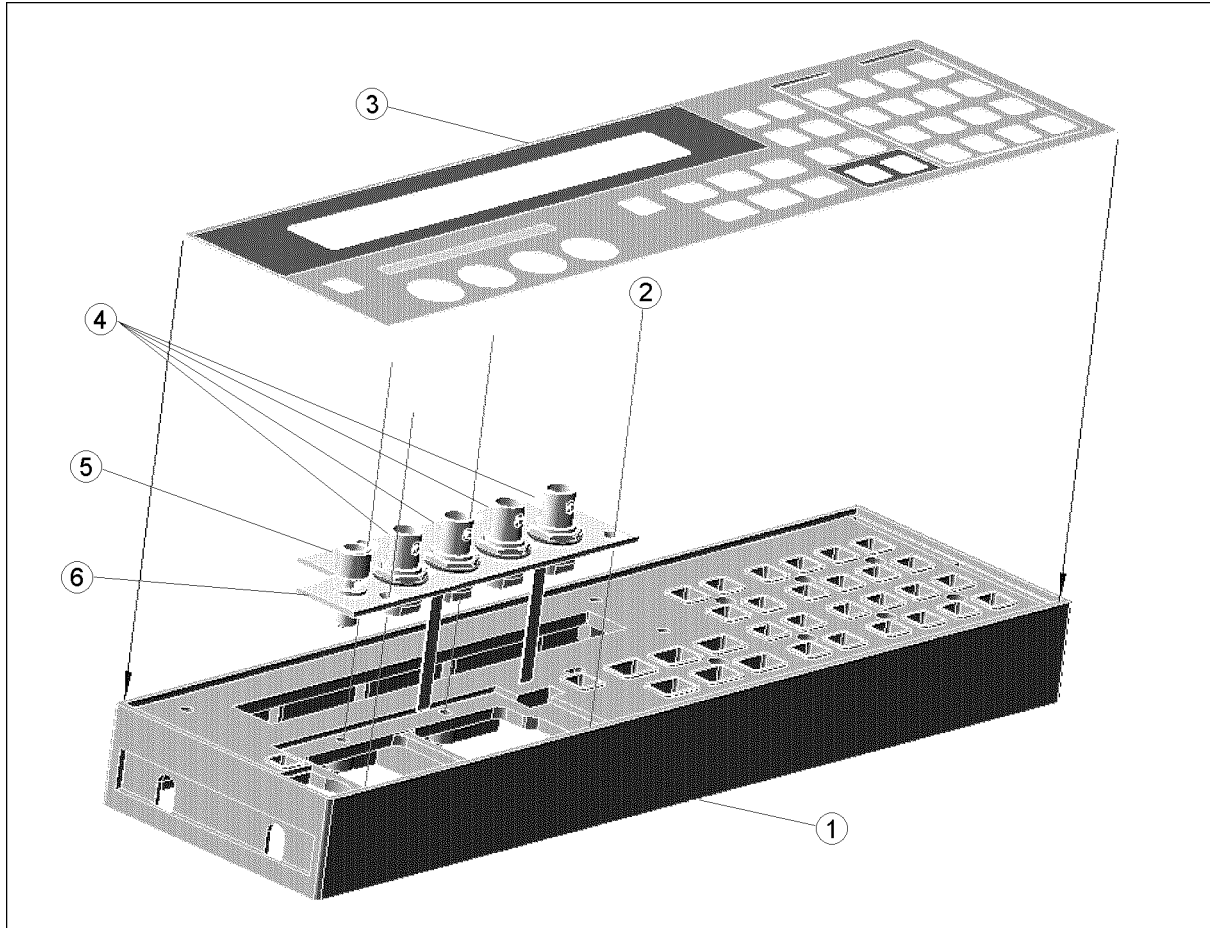

4268ase07005

Table 5-5 Front Assembly 1/4

Reference Designation	Agilent Part Number	Check Digit	Qty.	Description
1	04263-40001	6	1	Front Frame
2	0515-0914	8	4	Screw M3
3	04268-87121	4	1	Label Front
4	1250-0252	6	4	Connector BNC
	2950-0035	8	4	Nut (Outer Side)
	5040-3324	8	4	Insulator (Outer Side)
	5040-3325	9	4	Insulator (Inner Side)
	04263-01221	0	4	Terminal (Inner Side)
5	1510-0130	1	1	Binding Post
	2190-0067	4	1	Washer (Inner Side)
	2950-0006	3	1	Nut (Inner Side)
6	04263-00605	2	1	Sub Panel

Figure 5-6 **Front Assembly 2/4**

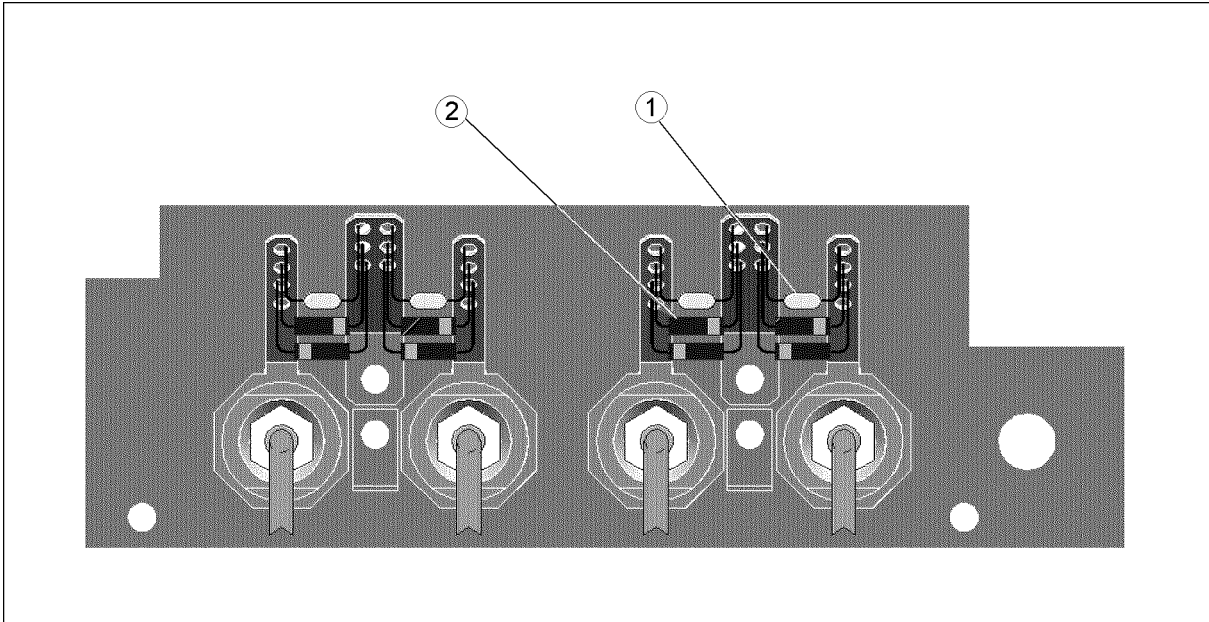

4268ase07006

Table 5-6 **Front Assembly 2/4**

Reference Designation	Agilent Part Number	Check Digit	Qty.	Description
1	0160-4808	4	4	Capacitor 470 pF
2	1901-1250	7	8	Diode

Figure 5-7 Front Assembly 3/4

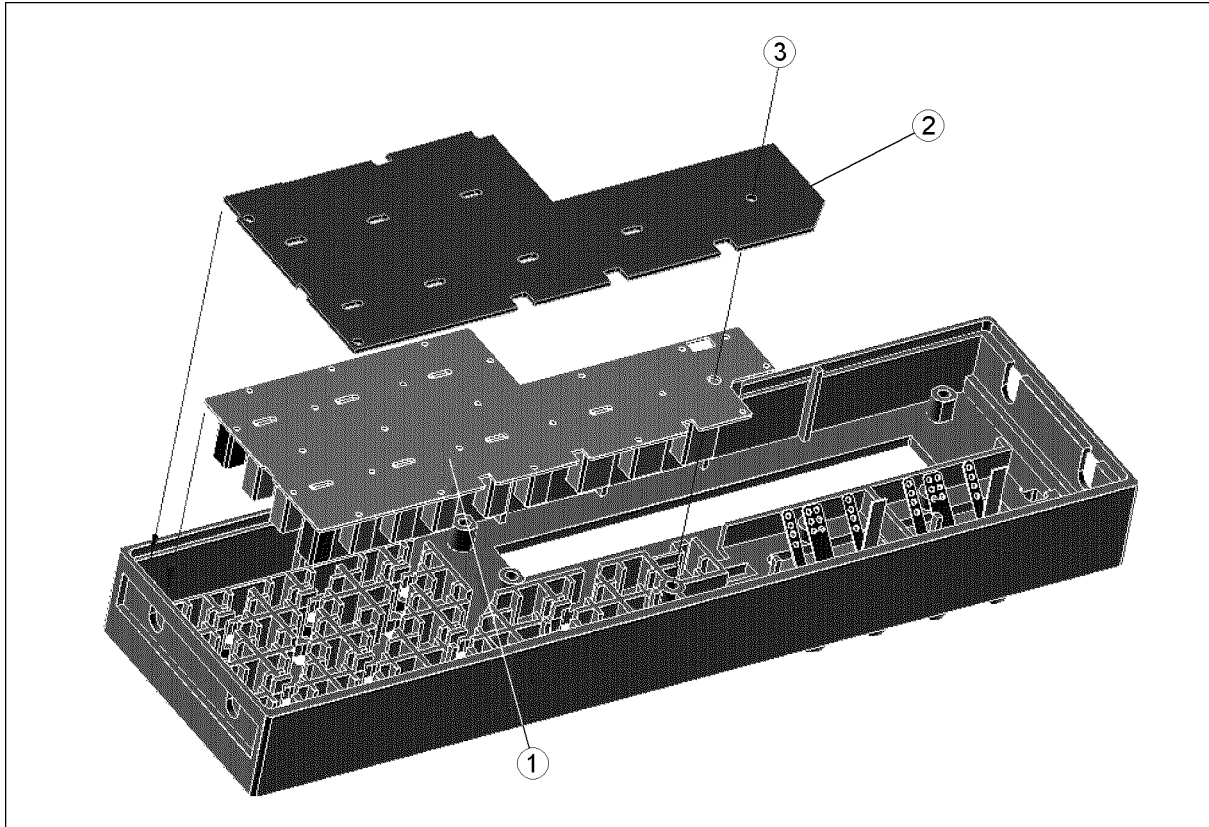

4268ase07007

Table 5-7 Front Assembly 3/4

Reference Designation	Agilent Part Number	Check Digit	Qty.	Description
1	04263-25151	5	1	Rubber Key
2	04263-66504	8	1	Key board Assembly
3	0515-1550	0	1	Screw M3

Figure 5-8 **Front Assembly 4/4**

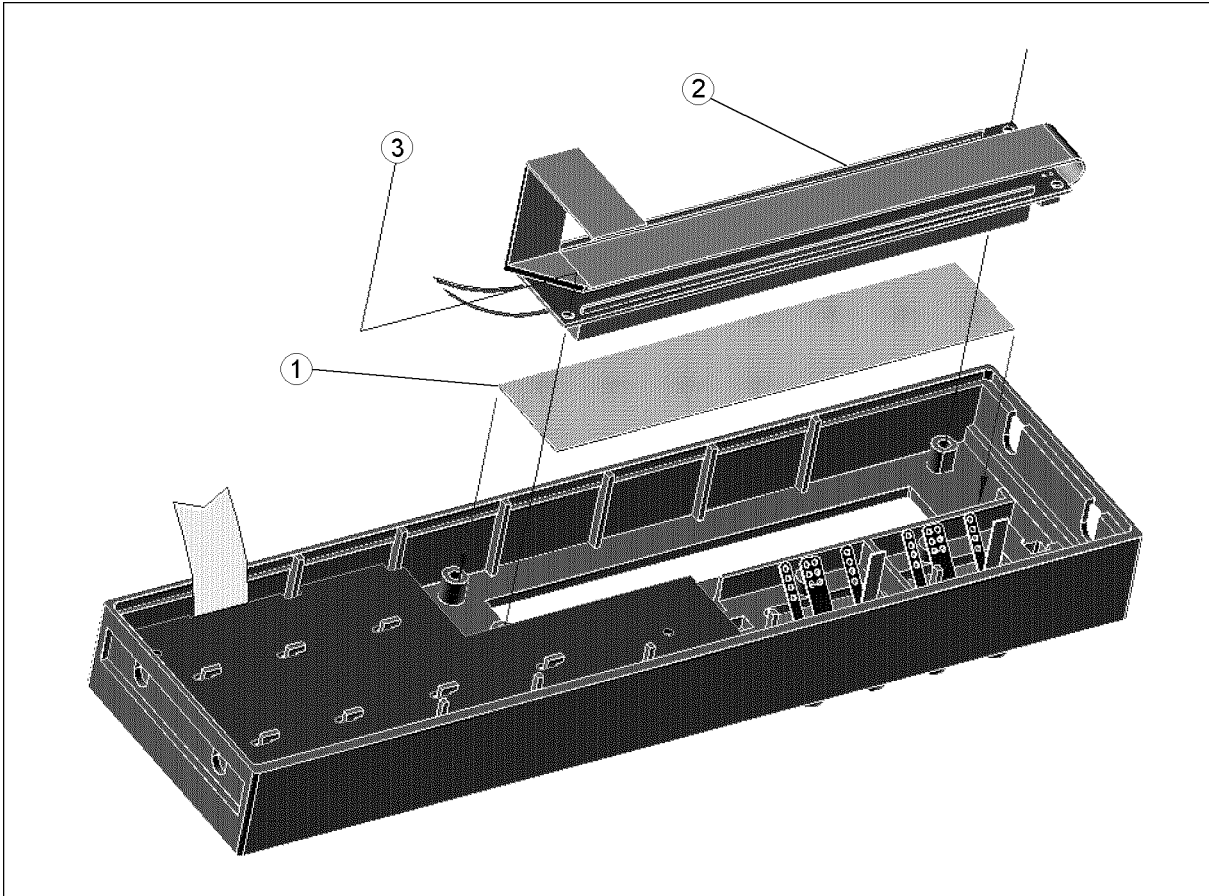

4268ase07008

Table 5-8 **Front Assembly 4/4**

Reference Designation	Agilent Part Number	Check Digit	Qty.	Description
1	04263-25003	6	1	Filter Transparent
2	04263-61010	1	1	LCD Assembly
3	0515-1550	0	2	Screw M3

Assembly Replacement
Replaceable Parts List

Figure 5-9 Rear View

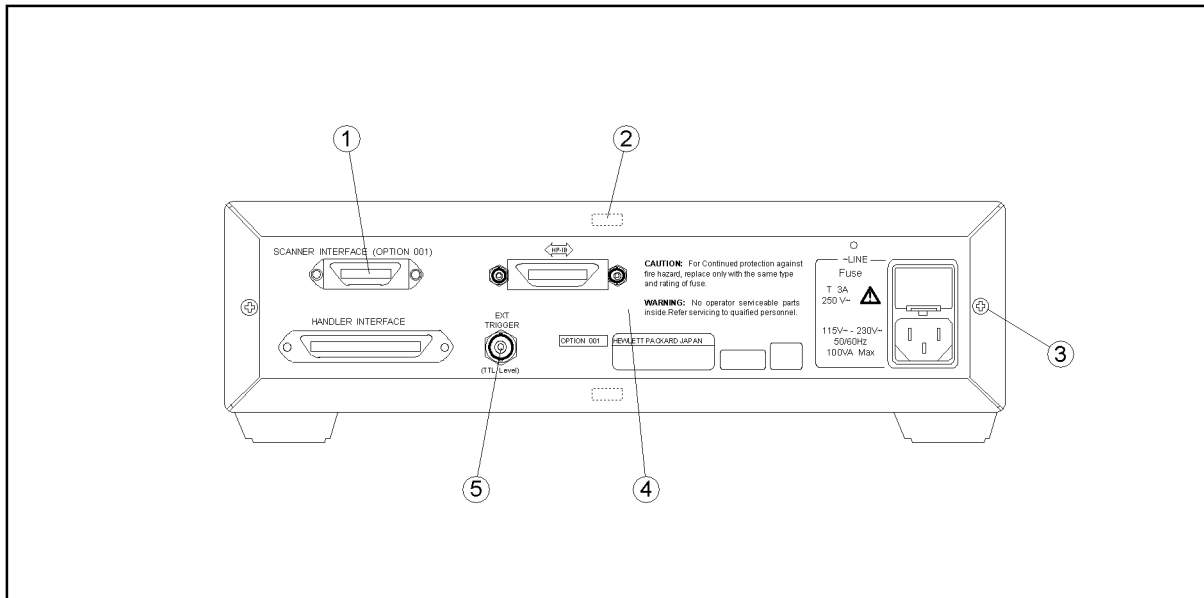

4268ase07009

Table 5-9 Rear View

Reference Designation	Agilent Part Number	Check Digit	Qty.	Description
1	04268-00211	1	1	Panel (without Opt. 001)
	0515-1550	0	2	Screw M3-L8 (without Opt. 001)
	04268-61605	5	1	Cable Assembly (with Opt. 001)
	0515-1551	1	2	Screw M3-L10 (with Opt. 001)
2	0363-0125	0	3 cm × 2	Gasket
3	0515-1551	1	2	Screw M3-L10
4	04268-00111	0	1	Chassis
5	2190-0054	9	1	Washer
	2950-0054	1	1	Nut

Figure 5-10 **Side View**

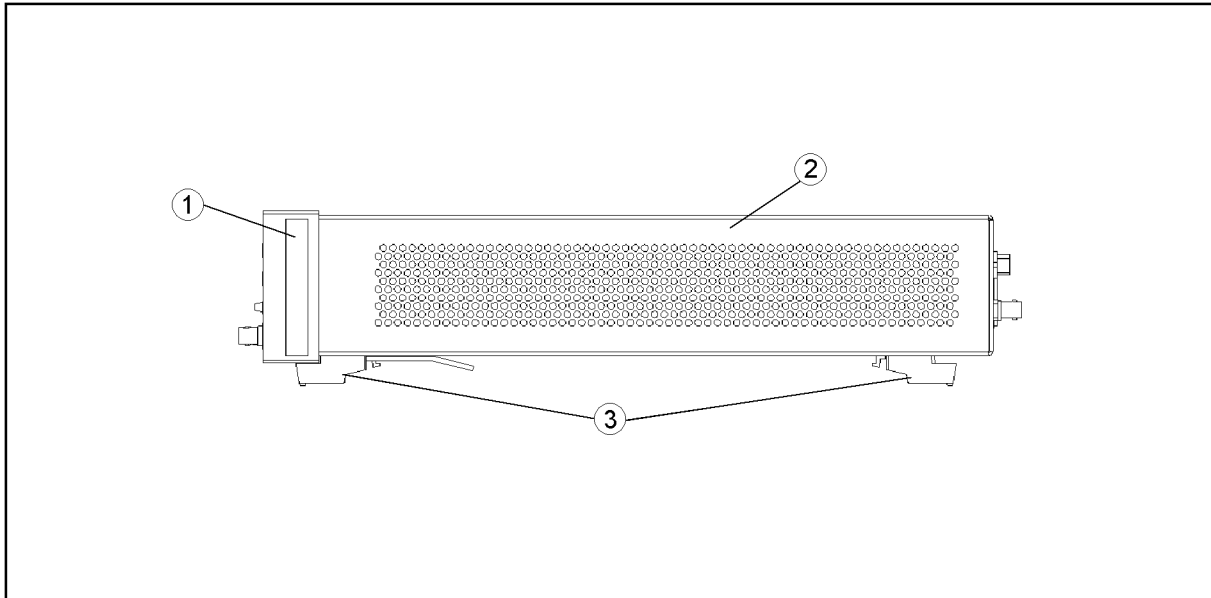

4268ase07010

Table 5-10 **Side View**

Reference Designation	Agilent Part Number	Check Digit	Qty.	Description
1	5041-9170	6	2	Trim Side
	0515-0914	8	4	Screw M3
2	04339-04004	4	1	Cover
3	5041-9167	1	4	Foot
	1460-1345	5	2	Tilt Stand

Figure 5-11 **A2 CPU Board**

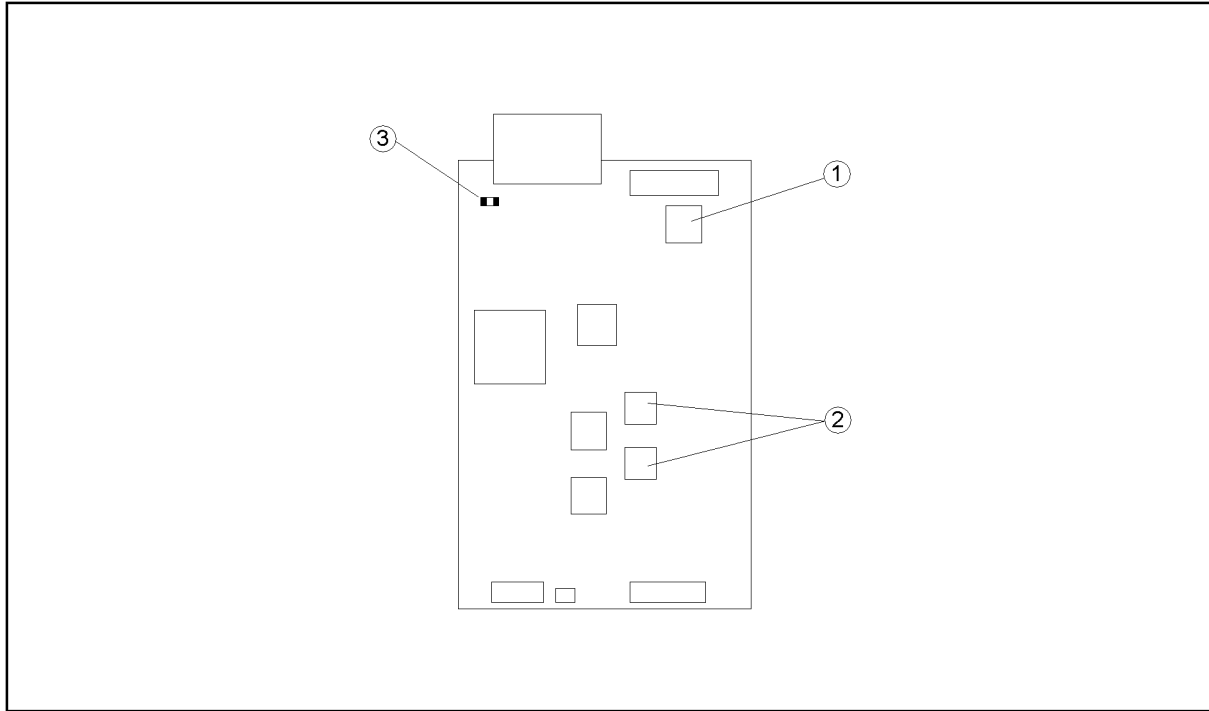

4268ase07011

Table 5-11 **A2 CPU Board**

Reference Designation	Agilent Part Number	Check Digit	Qty.	Description
1	04268-85031	1	1	Boot ROM
2	1818-7087	3	2	EEPROM
3	2110-1123	7	1	Fuse-SMT 2A 125V

Disassembly Procedure

WARNING The opening of covers or removal of parts is likely to expose dangerous voltages. Disconnect the instrument from all voltage sources while it is being opened.

CAUTION SUSCEPTIBLE TO DAMAGE FROM ESD

Perform the following procedures only at a static-safety workstation and a grounding strap.

Cover Removal

Tools Required

- Pozidriv screwdriver, pt size #1 (small)

Procedure

1. Remove the two screws which fasten the cover to the chassis rear panel.
2. Slide the cover toward the rear while holding the front panel bezel.

A1 Main Board Removal

Tools Required

- Pozidriv screwdriver, pt size #1 (small)
- Flat-blade screwdriver

Procedure

1. Remove the A2 CPU Board Assembly (refer to “A2 CPU Board Assembly Removal”).
2. Disconnect the following assemblies (items 2) from the A1 Board.
3. Remove the four cable assemblies (item 3) connected to the UNKNOWN Terminals
4. Remove the nut which fasten the Ext Trigger (item 4)connector to the rear panel.
5. Remove the four standoffs (item 5) that fasten the A1 assembly to the chassis, by rotating them with a flat based screwdriver.

Assembly Replacement
Disassembly Procedure

6. Remove the eight screws (item 6_a and 6_b) in Figure 5-12.

NOTE Don't remove any screws which fasten the transistors on A1 assembly.

7. Lift the front side of the A1 assembly, and slide it toward the front side.

NOTE When replacing to the re-built A2 board, return the defective A1 board.

Figure 5-12 A1 Main Board Removal

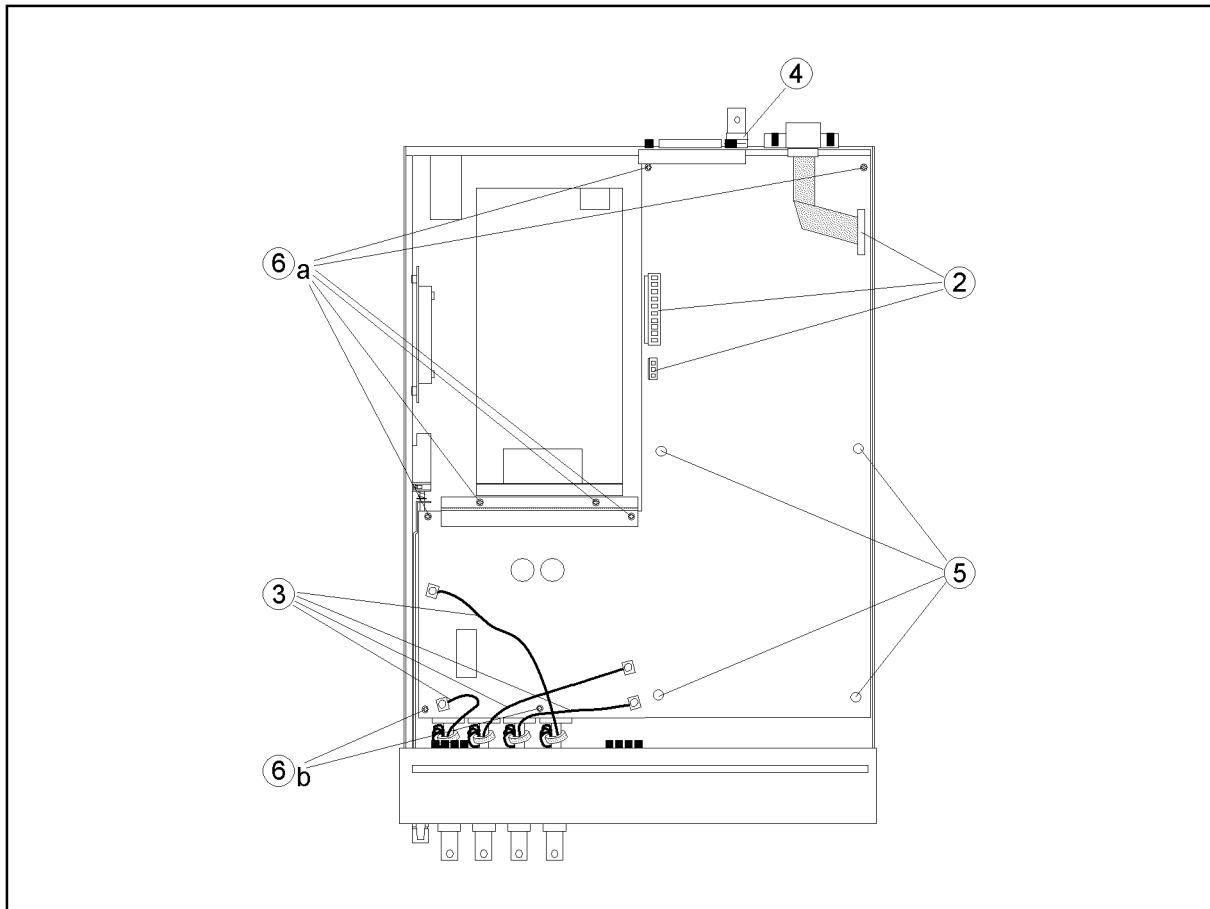

4268ase07012

A2 CPU Board Replacement

Tools Required

- Pozidriv screwdriver, pt size #1 (small)
- PLCC extractor

Removal Procedure

1. Remove the cover. (refer to “Cover Removal”).
2. Disconnect the cable assemblies (item 2_a and 2_b) in Figure 5-13.
3. Remove the four screws (item 3) which fasten the A2 board to the standoffs.

NOTE

Don't remove other screws on the A2 board.

4. Remove the A2 board from the chassis.

Replacement Procedure

5. Remove the EEPROM(item 5)from the A2 board using PLCC extractor. Mount the EEPROM on the replacement A2 CPU board.
6. Attach the Replacement A2 board with the screws removed in “Removal Procedure”.
7. Connect all cables disconnected in “Removal Procedure” to the A2 board.
8. Replace the bottom cover.

Figure 5-13 A2 CPU Board Replacement

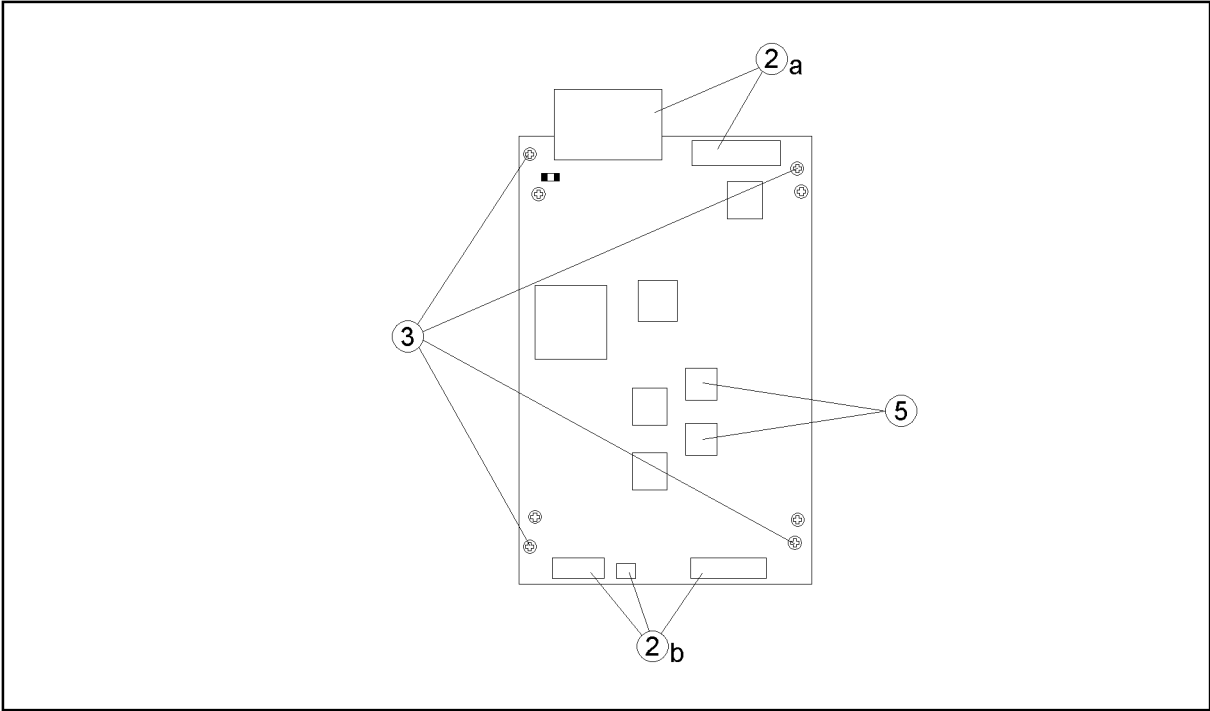

4268ase07013

Power Supply Assembly Removal

Tools Required

- Pozidriv screwdriver, pt size #1 (small)

Procedure

1. Remove the cover. (refer to “Cover Removal”).
2. Release two cables from the cable clamps (item 2_a and 2_b) in Figure 5-14.
3. Remove the cable assemblies (item 3) from the A1 board.
4. Remove the five screws (item 4) which fasten the shield to the chassis.
5. Remove the screw (item 5) on the side of the shield.
6. Disconnect the wire assembly (item 6) which is connected to the power switch.
7. Remove the cable assembly (item 7) from the Power Supply assembly.
8. Remove the two screws on the bottom cover.

Figure 5-14 **Power Supply Assembly Removal**

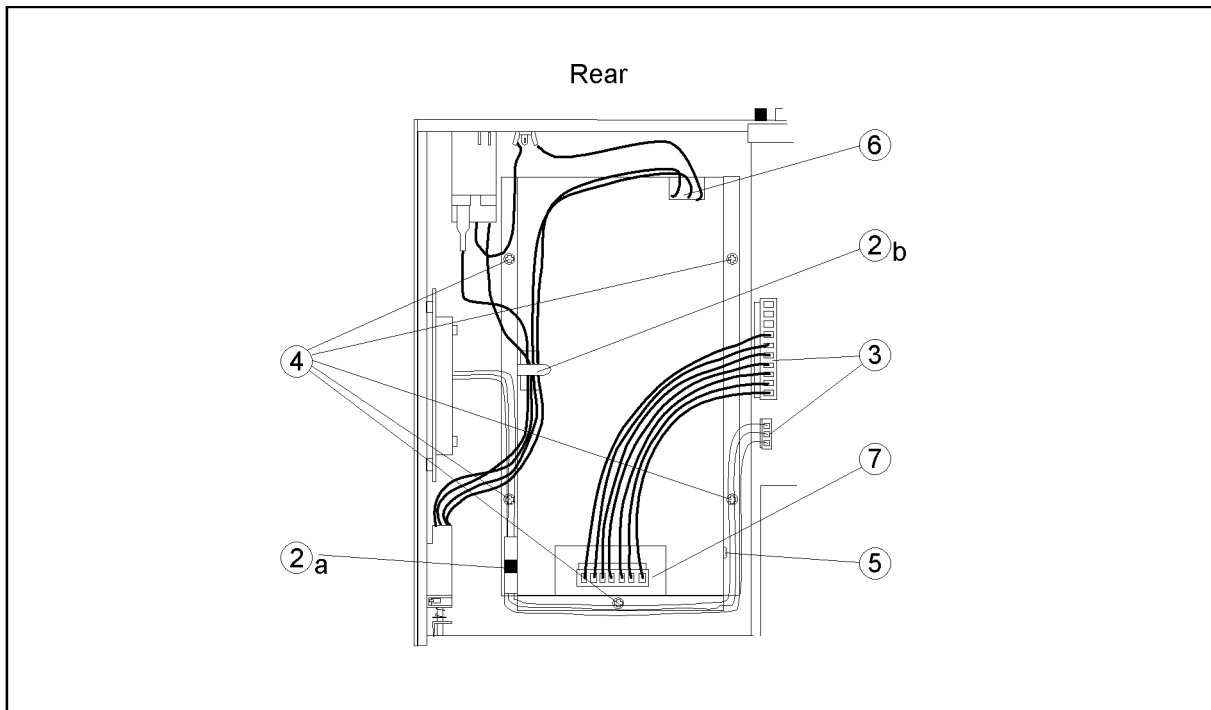

4268ase07014

Fan Assembly Removal

Tools Required

- Pozidriv screwdriver, pt size #1 (small)

Procedure

1. Remove the cover. (refer to “Cover Removal”).
2. Remove the cable attached with fan from the A1 board.
3. Remove the four screws which fasten the fan assembly from the side of the chassis.
4. Remove the four screws connecting the fan to the plate.

Front Assembly Removal

Tools Required

- Pozidriv screwdriver, pt size #1 (small)

Procedure

1. Remove the cover. (refer to “Cover Removal”).
2. Remove the wire assembly and the flat cable assemblies connected to the A2 assembly.
3. Remove the two flat head screws which fasten the front panel from the bottom.
4. Remove the side trim label from both sides of the front bezel.
5. Remove the four screws which fasten the front frame to the chassis from both sides.

LCD Assembly Removal

Tools Required

- Pozidriv screwdriver, pt size #1 (small)

Procedure

1. Remove the front Assembly (refer to “Front Assembly Removal”).
2. Place the front assembly face down.
3. Remove the two screws which fasten the LCD to the front panel bezel.
4. Remove the LCD assembly from the front panel bezel.

Keyboard Assembly Removal

Tools Required

- Pozidriv screwdriver, pt size #1 (small)

Procedure

1. Remove the front Assembly (refer to “Front Assembly Removal”).
2. Place the front assembly face down.
3. Remove the screw which fasten the keyboard to the front bezel.
4. Slide the keyboard assembly toward left and remove it.

BNC Connector Removal

Tools Required

- Pozidriv screwdriver, pt size #1 (small)
- Open-end wrench 9/16 inch

Procedure

1. Remove the front assembly (refer to “Front Assembly Removal”).
2. Place the front panel assembly so that the front panel face down.
3. Disconnect the cable assembly which is connected to the BNC connector.
4. Remove the core clamp supporting the cable disconnected in step 3.
5. Remove the nut which fasten the BNC connector to the sub panel.

EEPROM or Boot ROM Replacement

Required Tool

- Pozidriv screwdriver, pt size #1 (small)
- PLCC Extractor

Replacement Procedure

1. Remove the A2 CPU Board Assembly (refer to “A2 CPU Board Assembly Removal”).
2. Remove the EEPROM or the Boot ROM from the A2 CPU board using the PLCC Extractor.

Post Replacement Procedure

Table 5-12 lists the required procedures that must be performed after the replacement of an assembly or the EEPROM. These are the recommended minimum procedures to ensure that the replacement is successfully completed.

When you replace an assembly or the EEPROM on the A2 CPU, perform the adjustments and updating correction constant, then verify the 4268A performance according to Table 5-12.

For the detail of the adjustments and updating correction constants, see Chapter 3, “Adjustment.”.

Table 5-12 Post Replacement Procedure

Replaced Assembly or Part	Required Adjustment	Required Verification
A1 Main Board	All Adjustments	Power On Self-test ^a , All Performance Tests, All Function Tests
A2 CPU Board	Firmware installation, Adjustment ^b	Power On Self-test ^a , Performance Test ^b , Firmware Installation
A2 EEPROM	All Adjustments	All Performance Tests, Signal Level Monitor Function Test
Power Supply	None	Power-on Self-test ^a , All Performance Tests
Fan Assembly	None	Power On Self-test ^a
BNC Connector	None	Power On Self-test ^a , All Performance Tests
LCD Assembly	None	Power On Self-test ^a
Keyboard Assembly	None	Power On Self-test ^a , Front Keyboard Test ^c

- a. See “Power On Self-test” on page 79
- b. If the EEPROM is NOT transferred to the new board, all adjustments and performance tests are required.
- c. See “Front Panel Key Test” on page 80

Firmware Installation

Firmware may not be in new A2 CPU board. When you replace a faulty A2 CPU with a new one.

Required Controller

Computer	PC-AT compatible, RAM:64Mbytes, CPU:Pentium200MHz
OS	Microsoft Windows NT®(≥4.0), Windows 95®
Application	Agilent VEE(≥4.0)
GPIB Card	82350, 82340, 82341

Installation Program and Firmware File

The installation program is required to install the firmware. The stand alone firmware installation program or the adjustment program has capability of the installation. The firmware file of proper revision to be installed is also required.

Firmware installation Procedure

Perform following steps to install the firmware into the 4268A.

1. Turn the 4268A off. Then while pressing the 5 key, turn the 4268A on.
2. If “BOOTROM REV: xx.xx” and “Waiting DOWNLOAD” are displayed on the 4268A display, the firmware installation is prepared.
3. Run the firmrware installing program or the adjustment program.
4. In the program, enter a file name of the firmware file with directory.
5. After “Cycle Power to RUN” is displayed on the 4268A, turn the 4268A off and on.
6. Confirm the firmware revision on the 4268A’s display.

NOTE

An error “E20: Previous setting lost” might be displayed on the 4268A during the power on. If the error isn’t displayed after next power on testing, it’s normal.

Assembly Replacement
Firmware Installation

REGIONAL SALES AND SUPPORT OFFICES

For more information about Agilent Technologies test and measurement products, applications, services, and for a current sales office listing, visit our web site: <http://www.agilent.com/find/tmdir>. You can also contact one of the following centers and ask for a test and measurement sales representative. 11/29/99

United States:

Agilent Technologies
Test and Measurement Call Center
P.O.Box 4026
Englewood, CO 80155-4026
(tel) 1 800 452 4844

(fax) (61 3) 9272 0749
(tel) 0 800 738 378 (New Zealand)
(fax) (64 4) 802 6881

Canada:

Agilent Technologies Canada Inc.
5150 Spectrum Way
Mississauga, Ontario
L4W 5G1
(tel) 1 877 894 4414

Asia Pacific:

Agilent Technologies
24/F, Cityplaza One, 1111 King's Road,
Taikoo Shing, Hong Kong
(tel) (852)-3197-7777
(fax) (852)-2506-9284

Europe:

Agilent Technologies
Test & Measurement
European Marketing Organization
P.O.Box 999
1180 AZ Amstelveen
The Netherlands
(tel) (31 20) 547 9999

Japan:

Agilent Technologies Japan Ltd.
Call Center
9-1, Takakura-Cho, Hachioji-Shi,
Tokyo 192-8510, Japan
(tel) (81) 426 56 7832
(fax) (81) 426 56 7840

Latin America:

Agilent Technologies
Latin American Region Headquarters
5200 Blue Lagoon Drive, Suite #950
Miami, Florida 33126
U.S.A.
(tel) (305) 267 4245
(fax) (305) 267 4286

Australia/New Zealand:

Agilent Technologies Australia Pty Ltd
347 Burwood Highway
Forest Hill, Victoria 3131
(tel) 1-800 629 485 (Australia)

