

SL45 Level 2.5e

Repair Documentation



V 1.0

by Toko (toko@gsm-free.org)

Table of Contents:

- 1. LIST OF AVAILABLE LEVEL 2,5E PARTS SL45 4**
- 2. REQUIRED EQUIPMENT FOR LEVEL 2,5E SL45..... 5**
- 3. REQUIRED SOFTWARE FOR LEVEL 2,5E SL45 5**
- 4. RADIO PART 6**
 - 4.1. Power Supply RF-Part..... 6**
 - 4.2. Frequency generation 7**
 - 4.2.1. Synthesizer: The discrete VCXO (13MHz) 7
 - 4.2.2. Synthesizer: LO1 8
 - 4.2.3. Synthesizer: LO2 9
 - 4.2.4. Synthesizer: PLL 10
 - 4.3. Antenna switch (electrical/mechanical)..... 11**
 - 4.4. Receivers 13**
 - 4.4.1. Receiver: GSM900/1800 –Filter and LNA 13
 - 4.4.2. Receiver : Mixer, IF Amplifier and Demodulator 14
 - 4.4.3. Smarti IC Overview 15
 - 4.5. Transmitter..... 16**
 - 4.5.1. Transmitter: Modulator and Up-conversion Loop 16
 - 4.5.2. Transmitter: Power Amplifier and Antenna Switch 17
- 5. POWER SUPPLY 19**
 - 5.1. Overview and Voltages 19**
 - 5.2. STV-Schalke-ASIC 20**
 - 5.3. Power Supply MP3 (LARA)..... 24**
- 6.LOGIC PART 25**
 - 6.1. Overview Logic..... 25**
 - 6.2. Overview EGOLD+..... 26**
 - 6.3. Overview EGAIM 28**
 - 6.4. Overview MMG ASIC 31**
 - 6.5. MP3 (LARA) HW components 32**
 - 6.6. FLASH memory 33**
 - 6.7. Real time clock inside the EGOLD+..... 33**
 - 6.8. IrDA 33**

6.9.	SIM.....	34
7.	ACOUSTICS	34
7.1.	General.....	34
7.2.	Vibra.....	34
7.3.	Microphone.....	35
7.4.	Loudspeaker	36
8.	ILLUMINATION AND KEYBOARD:.....	39
8.1.	Illumination	39
8.2.	Keyboard	40
9.	CONNECTORS	41
9.1	I/O connector	41
9.2	Battery connector.....	42
9.3	Display connector.....	42
9.4	MMI connector.....	43

1. List of available level 2,5e parts SL45

ID-No	Type	Name(function)/Location	Rep-Code	Order No.
D100	IC	EGOLD+	4EGO	L36810-G6103-D670
D250	IC	SCHALKE_ASIC/Pow.Supply	4PSA	L36145-J4682-Y29
D400	IC	MP3 (LARA) 1	4LA1	L36820-C6118-D670
D401	IC	MP3 (LARA) 2	4LA2	L36820-U6068-D670
D470	IC	MMG_SCHALKE_ASIC	4MMG	L36145-J4681-Y54
D490	IC	Volt.Reg/RF	4REG	L36820-C6148-D670
D500	IC	SMARTI	4SMA	
D550	IC	LNA/RF	4LNA	L36820-L6047-D670
N600	IC	Op.Amp/RF	4OPA	L36810-C6046-D670
N630	IC	Volt.Reg/RF	4REG	L36820-C6070-D670
N631	IC	Volt.Reg/RF	4REG	L36820-C6147-D670
V251	Transistor	Charge/Logic	4CHT	L36830-C1064-D670
V530	Transistor	VCO_SW/RF	4SWT	L36820-C6047-D670
V601	Transistor	PA_Cont./RF	4SWT	L36840-C4014-D670
V651	Transistor	PA_Cont./RF	4SWT	L36840-C4009-D670
V653	Transistor	PA_Cont./RF	4SWT	L36840-C2074-D670
V810	Transistor	13_AMP/RF	4SWT	L36840-C4039-D670
Z100	Quarz	EGOLD+/Logic	4OSC	L36145-F102-Y14
Z400	Quarz	Quarz/MP3 (LARA)	4OSL	L36145-F260-Y13
Z500	Filter	IF_360/RF	4IFF	L36145-K280-Y127
Z530	VCO	1LO/RF	4VC1	L36145-G100-Y32
Z555	Filter	RX-PCN/RF	4FI1	L36145-K280-Y167
Z556	Filter	RX-GSM/RF	4FI3	L36145-K280-Y160
Z570	VCO	TX/RF	4VCT	L36145-G100-Y32
Z650	IC	Power_Amplifier	4PAM	L36851-Z2002-A45
Z800	Quarz	13MHz/RF	4VCX	L36145-F220-Y4

2. Required Equipment for Level 2,5e SL45

- GSM-Tester (CMU200 or 4400S incl. Options)
- PC-incl. Monitor, Keyboard and Mouse
- Bootadapter 2000 (L36880-N9241-A200)
- Troubleshooting Frame P35 (F30032-A82-A1)
- Power Supply
- Spectrum Analyser (Advantest 3162)
- RF-Probe incl. Power Supply (e.g. from Agilent)
- Oscilloscope incl. Probe
- RF-Connector (N<>SMA(f))
- Power Supply Cables
- Dongle (F30032-P28-A1)
- BGA Soldering equipment

Reference: Equipment recommendation Level 2,5e

3. Required Software for Level 2,5e SL45

- Windows NT Version4
- Winsui version1.22 or higher
- Winswup
- Windows software for GSM-Tester (Cats or CMU-GO)
- Software for 13MHz adjustment
- Internet unblocking solution

4. Radio Part

The radio part converts the I/Q base band signals supplied by the logic (EGOLD+) into RF-signals with characteristics as per the GSM recommendation (transmission) which are radiated by the antenna.
Or the radio part converts the received GMSK signal supplied by the antenna into IQ base band signals which can then be further processed by the logic (EGOLD+). The radio part is designed for Dual Band operation and can therefore serve the frequency bands EGSM900 and GSM1800. The radio part can never transmit and receive in both bands simultaneously. However, the monitor time slot can be selected independently of the frequency band. Transmitter and receiver are of course never operated simultaneously.

Notes

The radio part consists of the following blocks:

- Power supply (RF-Voltage regulators)
- Synthesizer (partly located in SMARTI)
- Receiver (partly located in SMARTI)
- Transmitter (Up conversion loop partly located in SMARTI)
- Transmitter (Power amplifier)
- Antenna Switch

4.1. Power Supply RF-Part

Two voltage regulators (N630/631) with a nominal output voltage of 2.8V are used, to perform the required "RF-Voltages".

The voltage regulator N630 is activated via SLEEPQ provided by the EGOLD+ (TDMA-Timer H13).

The voltage regulator N631 is activated via VCXOEN provided by the EGOLD+ (Functional P7).

The name of the voltages are: a) VCC_SYN activated by VCXOEN and b) VCC2_8 activated by SLEEPQ

For both voltages BATT+ is required.

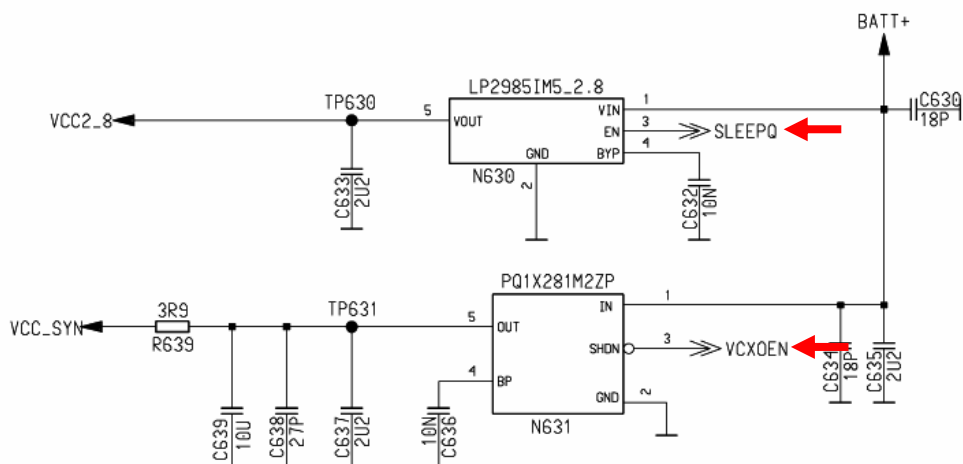

4.2. Frequency generation

4.2.1. Synthesizer: The discrete VCXO (13MHz)

The generation of the 13MHz signal is done in the SL45 via a discrete VCXO. A Colpitts oscillator with a crystal Z800 and a post-switched buffer stage is used as oscillator switch.

The subsequent oscillating circuit (C807,C817, L800) and the resistor R806 create a de-coupling of the synthesiser from interference signals coming from the logic (SIN13M (functional M14)).

The oscillator frequency is controlled by the (AFC_PNM) signal which is generated from the EGOLD+ (D100 (functional R3)) and the capacity diode V800.

To reduce the charging time of the low pass (R816, C816) the resistor R816 is bridged by the diode V802

For the temperature control a temperature-dependent resistance R802 is placed near the VCXO.

The required voltage VCC_SYN is provided by the N631

The picture 4211 shows the SIN 13M measured at TP120.

Notes

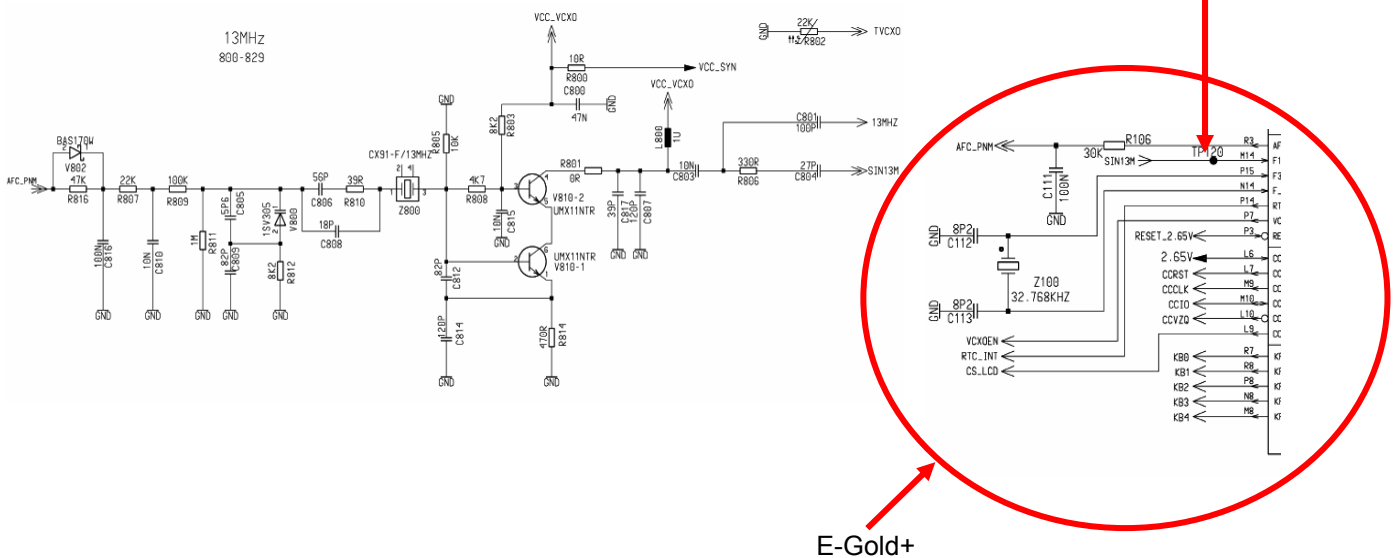
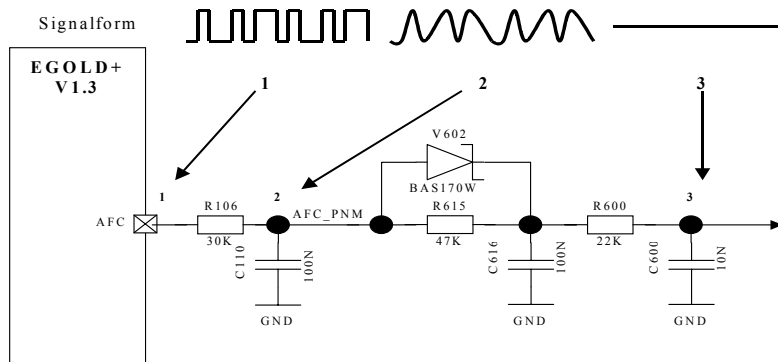

4.2.3. Synthesizer: LO2

The second local oscillator (LO2) consists of the PLL part of the Smarti (D400), 2 internal VCO's (1440 MHz for RX-Mode and 1696 MHz for TX-Mode) and an external filter (C509,C510,R501), Both frequencies are divided by 4 to get the 360MHz demodulator IF frequency and the 424MHz modulator frequency. The RX/TX switching is done internally and is initiated by the EGOLD+ through the SYGCCL, SYGCDT, SYNSTR (RF Control K14, K15, M15) signals. Responsible for switching "On/Off" the second local oscillator in the EGOLD+ signal PUPLO2 (TDMA-Timer L11) at SMARTI pin 16.

Notes

The required voltage VCC2_8 for D400 is provided by N630

The picture 4231 shows the VCO output signal

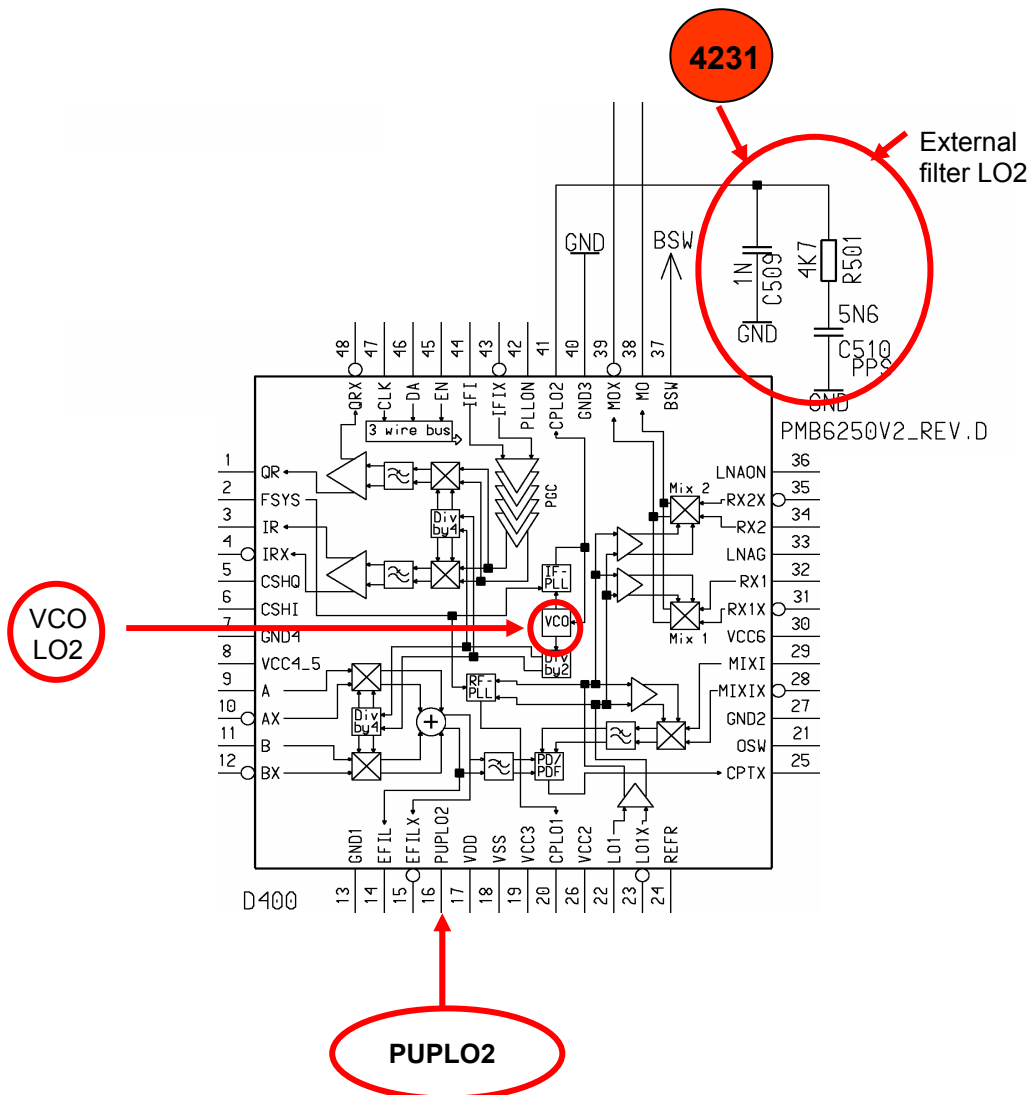

4.2.4. Synthesizer: PLL

PLL as a part of the PMB6250 (Smarti) IC

Blockdiagramm

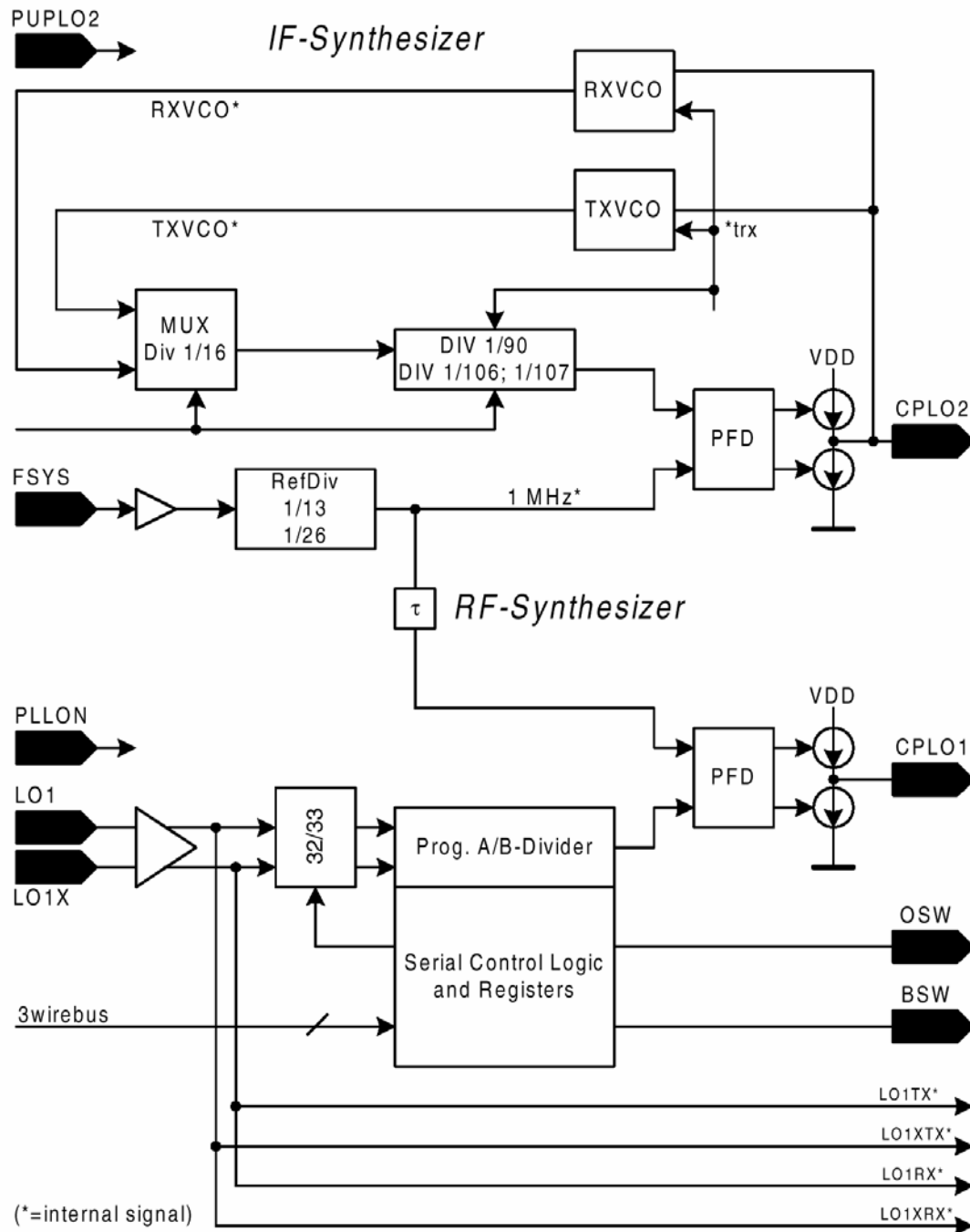

4.3. Antenna switch (electrical/mechanical)

Internal/External <> GSM900/1800 <> Receiver/Transmitter

Notes

The SL45 mobile consists of two antenna switches.

- a: The mechanical antenna switch ([connector X675](#)) for the differentiation between the internal and external antenna

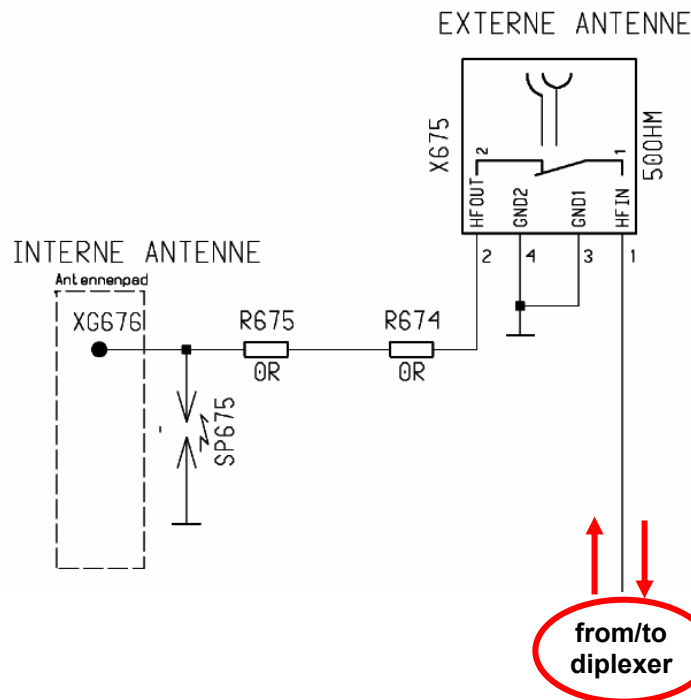

- b: The electrical antenna switch ([Diplexer Z670](#)) for the differentiation between the receiving and transmitting signals, just like the differentiation between GSM900 and GSM1800. To do so the Transistors [V672](#), [V673](#) are used to switch the diplexer input signals [VC1-VC4](#) as required.

The required voltage [VCC2_8](#) for [D400](#) is provided by [N630](#)

Notes

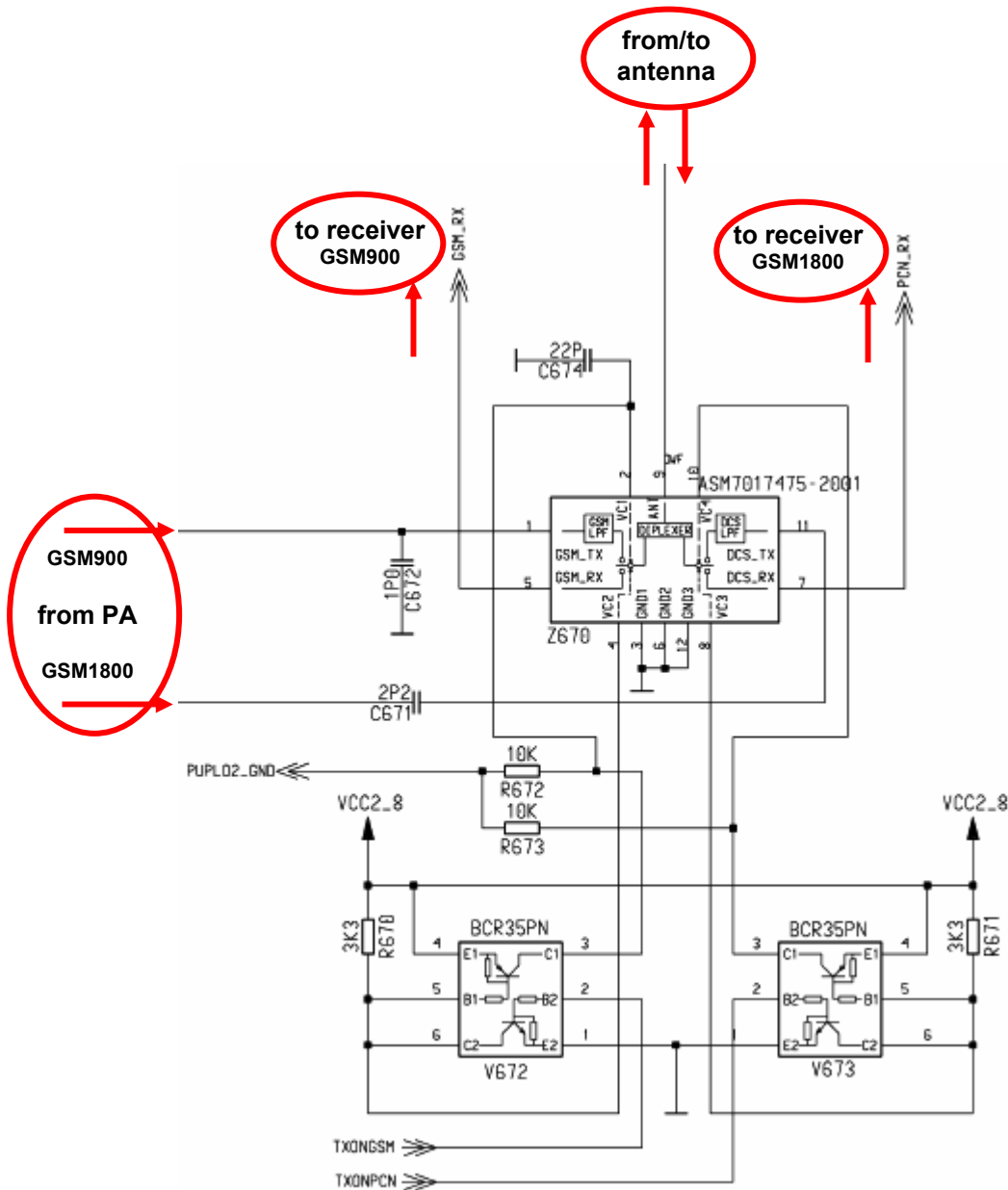

The matrix below shows the different conditions at the Diplexer and the accompanying signals.

	VC1	VC2	VC3	VC4
GSM Rx	0	1	1	0
Tx	1	0	1	0
PCN Rx	0	1	1	0
Tx	0	1	0	1

4.4. Receivers

4.4.1. Receiver: GSM900/1800 –Filter and LNA

From the antenna switch, up to the IF-Mixer the GSM1800 receiver circuit consists of a ceramic front end filter (Z555), a LNA (Low Noise Amplifier D550) and a discrete distortion LC-high-pass-filter after LNA amplification.

For GSM900 the signal flow is as follows: From the antenna switch via a SAW filter (Z556) through the LNA (D550) and a discrete distortion LC-low-pass-filter to the IF-Mixer.

The amplification of both LNA's is approx. 18dB with a matched 50 ohm output. To switch on the LNA, the signal LNAON (Smarti pin 36) is used.

LNAG (Smarti pin 33) is in use if the received signal level is too high. With the high signal LNAG the LNA reduces the incoming signal in one step by 20dB

For activating the GSM1800 or the GSM900 LNA part a signal BSW is generated from the (Smarti pin 37)

The non-symmetrical output of the LNA (D550) is connected to the IF mixer via a discrete balancing and adaptation circuit This circuit converts the asymmetrical input signal into a symmetrical signal.

The required voltage VCC2_8 is provided by the N630

Notes

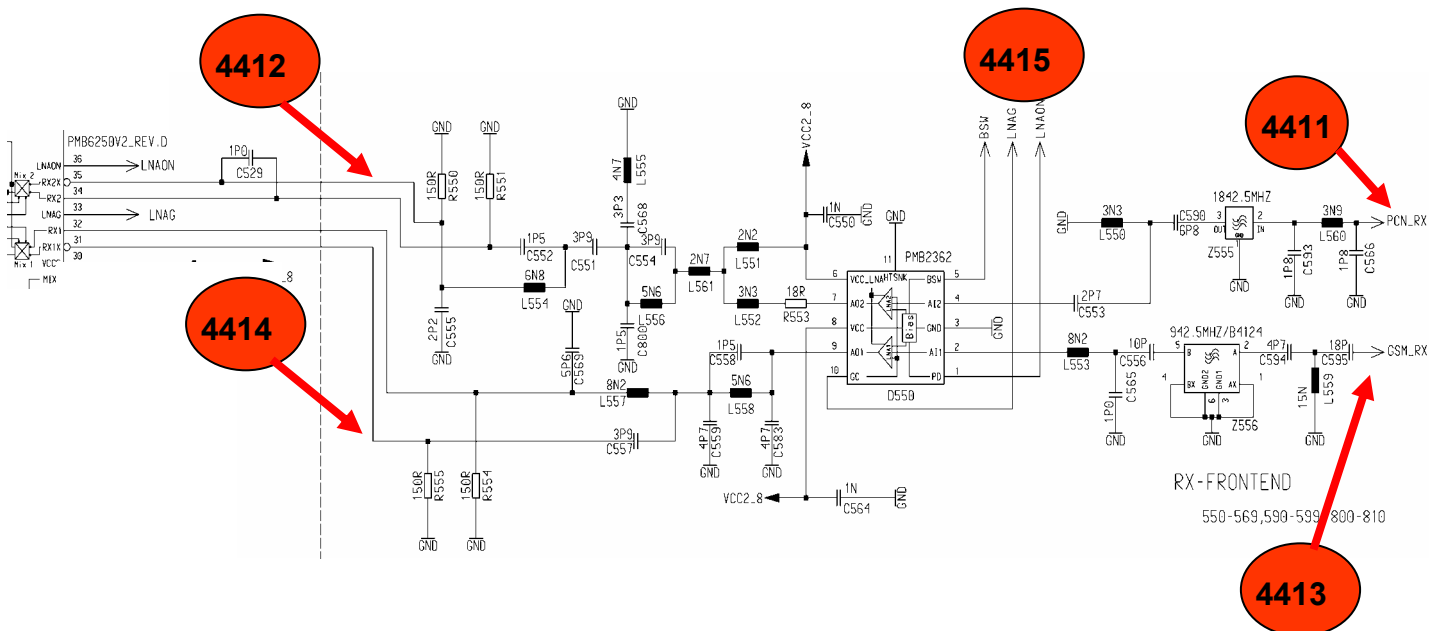

4.4.2. Receiver : Mixer, IF Amplifier and Demodulator

The Smarti IC (D400) has two separate input mixers one for EGSM900 and one for GSM1800.
 The mixing result for both mixers is an intermediate frequency from 360 MHz.
 The GSM900 mixer works in inverted sideband mode (LO1 above RX frequency), the GSM1800 mixer in step mode (LO1 below RX frequency).
 The outputs of both mixer are connected to the same IF Filter.
 After passing an external IF Filter (Z500) the signal arrives at the programmable IF amplifier in the Smarti. This amplifier has a dynamic of 80dB (-20dB to 60dB) and can be set (PGCSTR;SYGCDT;SYGCCCL) in 2dB steps.
 Finally the signal is mixed down by the IQ demodulator to differential I and Q (RX_I,RX_IX-RX_Q,RX_QX) signals off 50mV_{pp}.
 This signals are guided to the EGold+ A/D converters in the base band path.

Notes

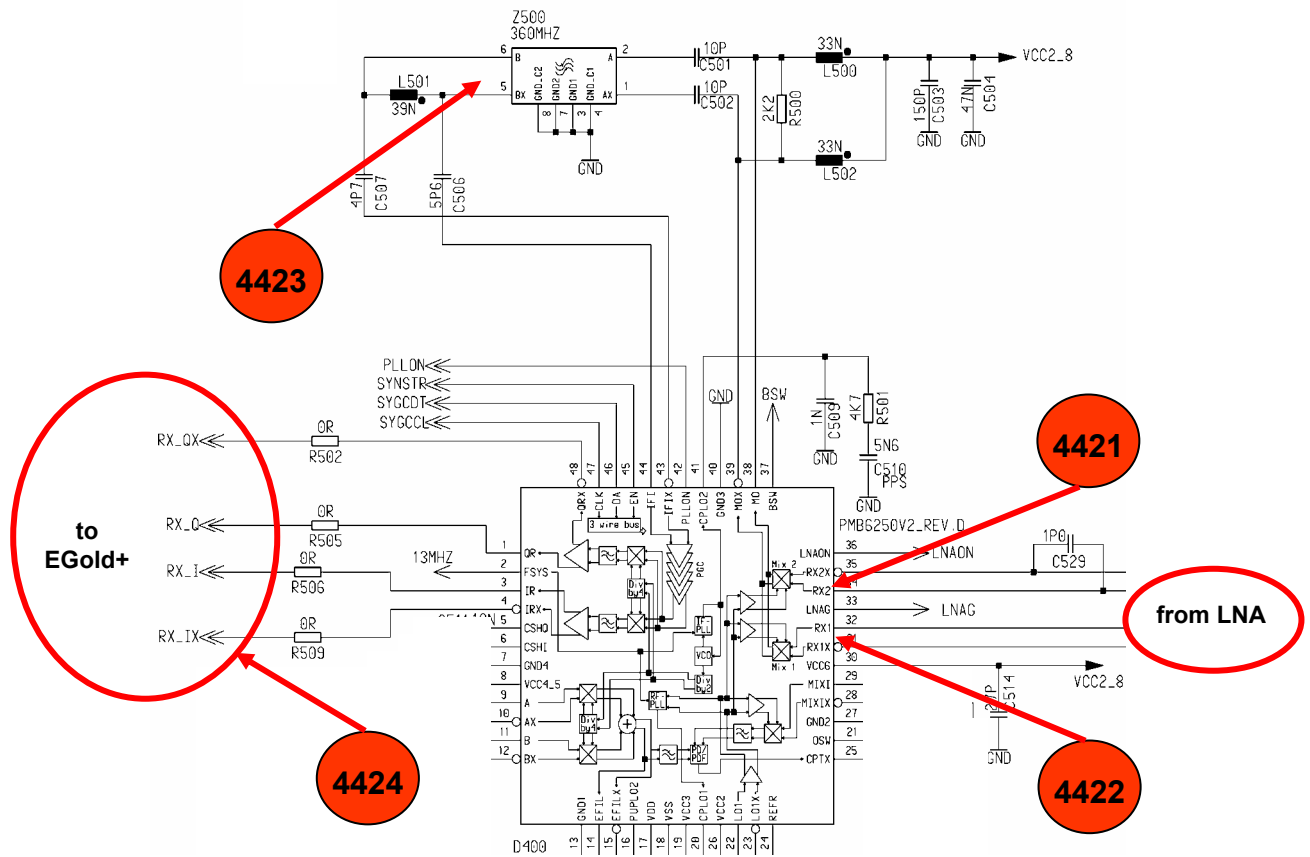

4.4.3. Smarti IC Overview

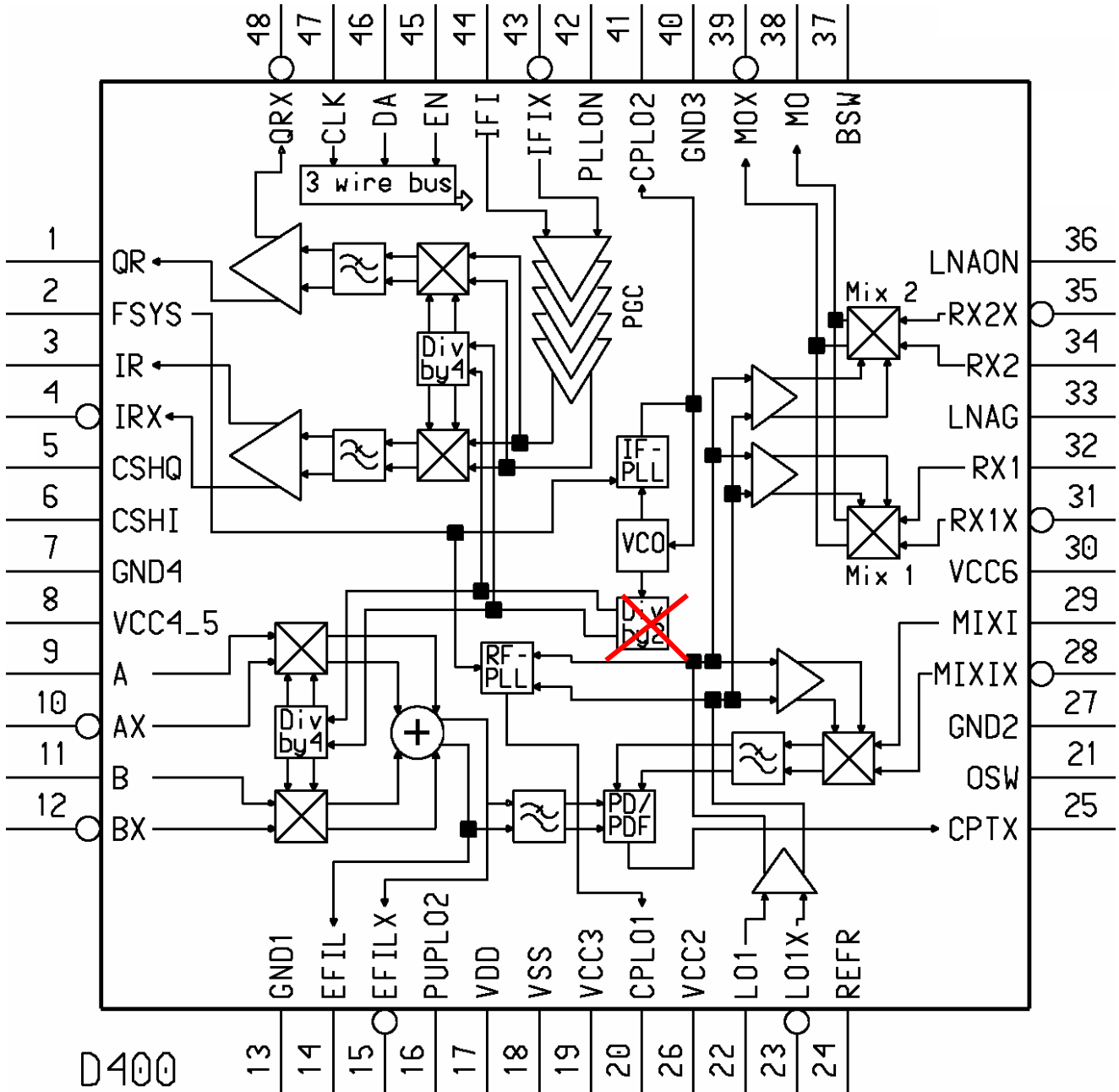

X Not active

4.5. Transmitter

4.5.1. Transmitter: Modulator and Up-conversion Loop

The SL45 modulation is based on the principle of the up-conversion modulation phase locked loop and is accomplished via the **Smarti IC(D400)**.

The **Smarti IC** provides the quadratic modulator working with the TX IF frequencies GSM/PCN 424 MHz. Whereby these frequencies are supplied from the second local oscillator signals (1694MHz/4).

This so generated GMSK RF signal is compared in a phase detector with the down mixed GMSK RF output.

To get the comparison signal the **TXVCO_OUT** signal is mixed with LO1 signal.

With the help of the 1.LO the GMSK-RF signal appearing at the output of the TXVCO (**Z570**) is mixed to a TX IF below the TX signal and is led on to the phase detector. The I-Q modulated signal in the IF position is also led to the phase detector.

The output signal of the phase detector passes a discrete loop filter realized by capacitors and resistors and force the TXVCO to work on the right frequency.

This large loop band width guarantees that the regulating process is considerably quicker than the changes in the modulation signal.

The TXVCO is a so-called two-in-one VCO, this means the VCO module contains the GSM900-VCO and the GSM1800-VCO in one housing.

The TXVCO is switched from GSM to PCN by using the signals **GSM_TX_VCOENQ** and **PCN_TX_VCOENQ** from the **EGold+ (TDMA Timer J13, K12)**

The required voltage **VCC2_8** is provided by **N630**

The required voltage **VCC_SYN** is provided by **N631**

Notes

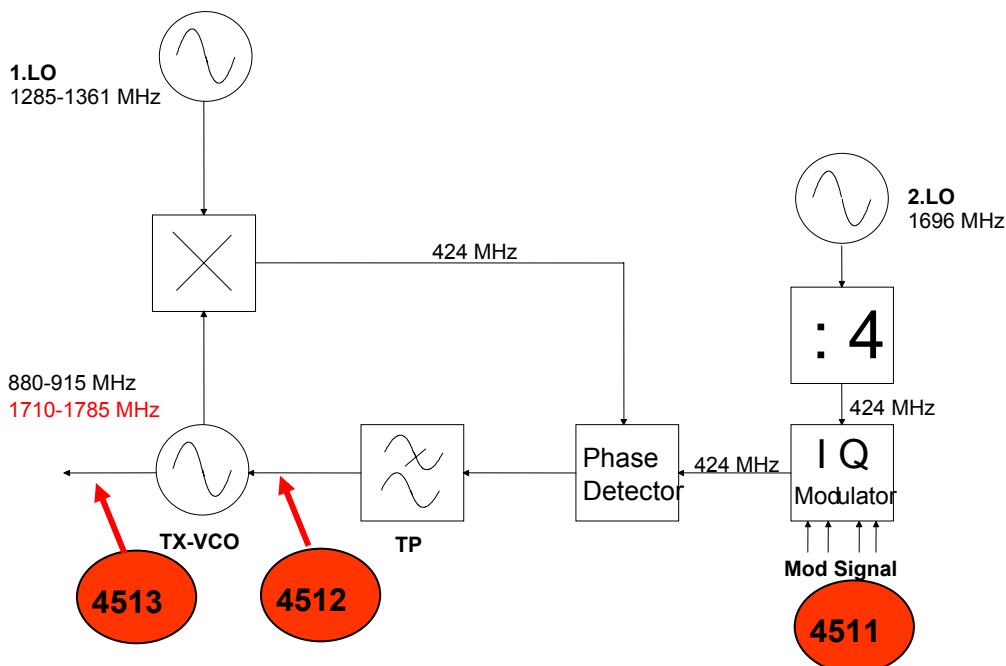

4.5.2. Transmitter: Power Amplifier and Antenna Switch

Splitted by a discrete circuit into GSM900 (low pass R651/L650) and GSM1800 (high pass R652/C651) the TXVCO output signal arrives at the power amplifier. The dual band power amplifier module (Z650) is assembled on a ceramic substrate in one housing. The module amplifies the output signal of the TXVCO to the required PCL. Controlled by the feedback circuit according to settings from the logic.

A part of the TX output signal is decoupled via a directional coupler (realised by conductive tracks) and is equalised at a detector diode (V620).

This so gained voltage is compared by an operation amplifier (N600) with the PA_RAMP signal provided by the EGold+ (GAIM/BASEBAND H2), to ensure that the PA is working within the required PCL's.

The different amplifiers are selected on by the PCN_TX_VXCOENQ signal from the EGold+ (TDMA Timer K12). The power amplifier is feeded directly from the battery (BATT+).

After amplification the signal passes on the way to the antenna the diplexer (Z670) and antenna connector (X675).

Notes

The required voltage BATT+ is provided by the battery.

The required voltage VCC2_8SW is provided by transistor V600.

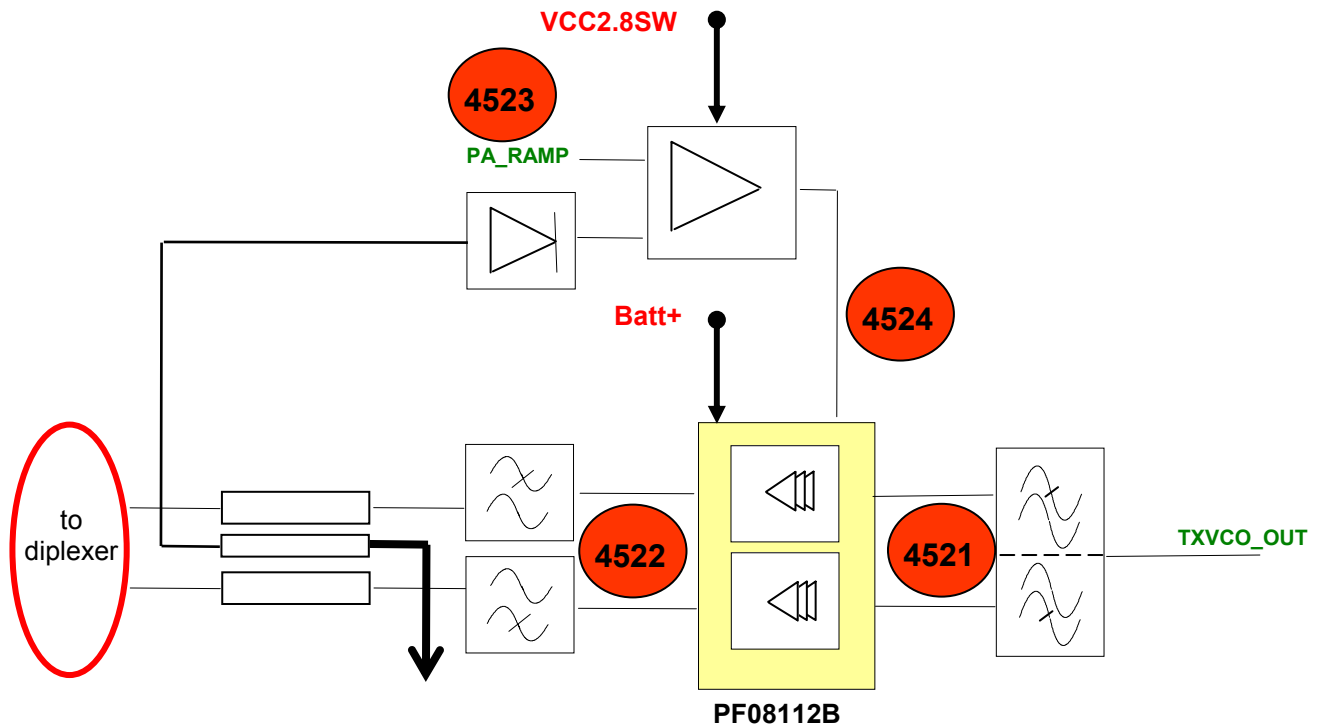

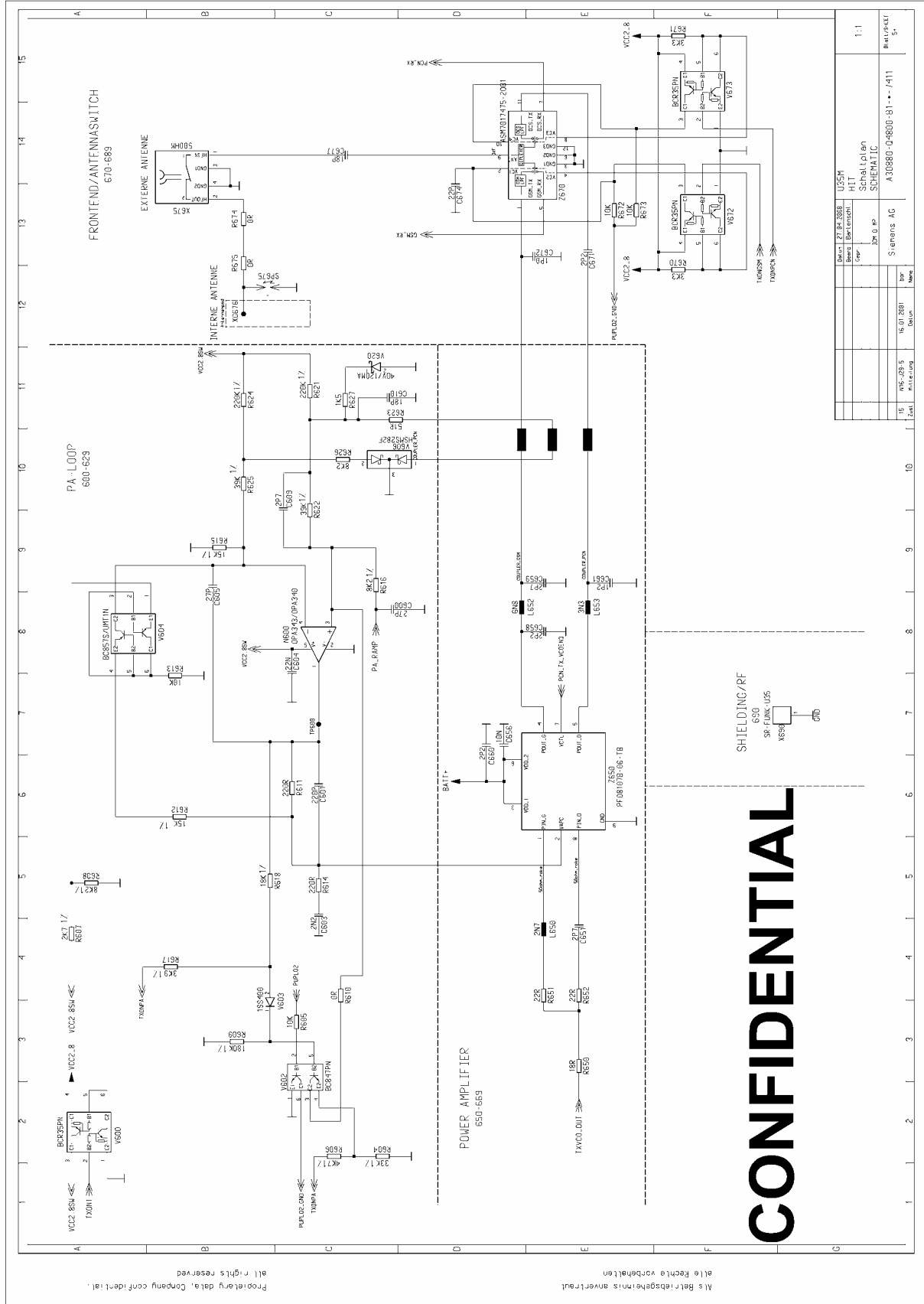

Proprietary data, Company confidential. All rights reserved.

Alle Rechte vorbehalten. Ms Betriebsgeheimnis unvertraut.

Detail	Z1 BR 2088	U25M
Bezeichnung	Bezeichnung	HIT
Typ	Typ	Schaltplan
Druck	Druck	SCHEMATIC
Version	Version	A30880-04800-81-.../411
Erstellt	16.01.2001	Erstellt
Geprüft		Geprüft
Freigegeben		Freigegeben
Maßstab	1:1	Maßstab

5. Power Supply

5.1. Overview and Voltages

Notes

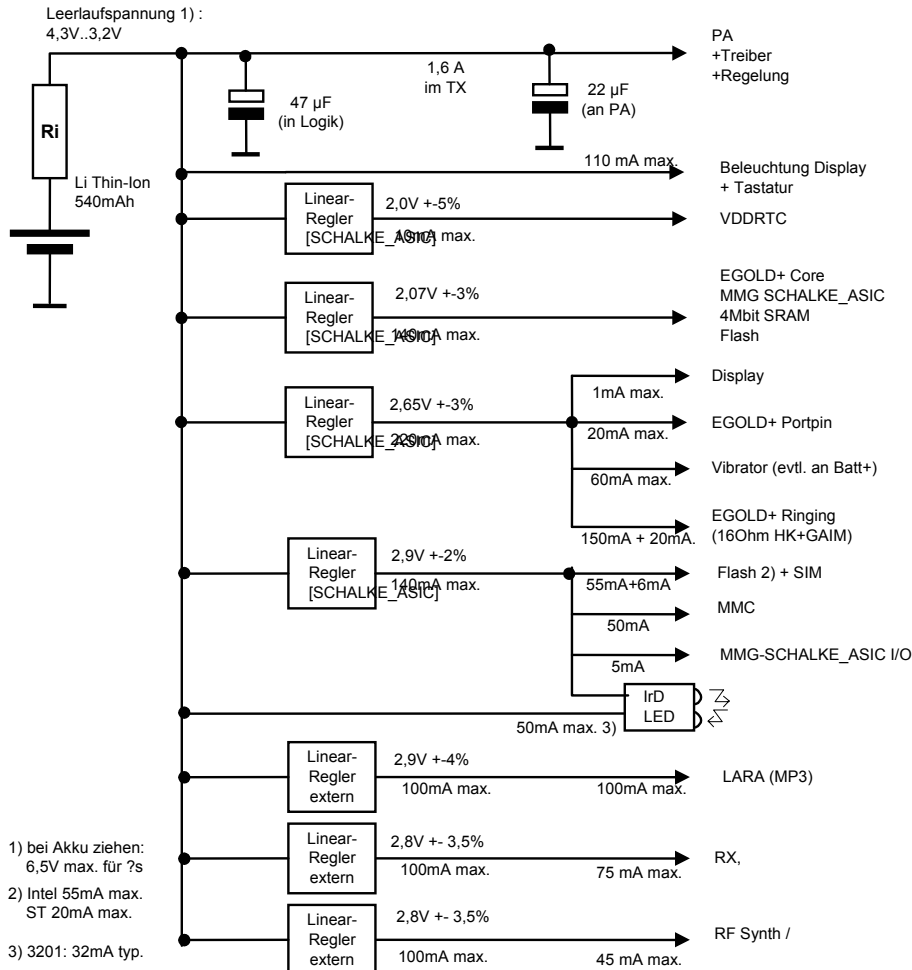

The following restrictions must be observed:

- The phone cannot be operated without battery.
- The phone will be damaged if the battery is inserted the wrong way round (the mechanics of the phone prevent the battery from being put in the wrong way round). The electric system assumes that the battery as been inserted correct.

5.2. STV-Schalke-ASIC

The power supply Schalke-ASIC contains the following functions:

- Control of “**switching on**” the mobile phone via
 1. The **ON/OFF** Key. (Schalke-ASIC F4)
 2. The bottom connector with the signal **VDD_CHARGE** (Schalke-ASIC A4)
 3. The **Real Time Clock RTC_Int** (Schalke-ASIC F5)
- Watchdog monitoring
 1. Control of “**switching off**” the mobile phone via **WATCHDOG_μP**.
 2. Watchdog observation
- Switch off of mobile phone in the case of overvoltage at battery connection.
- Generation of **RESET** signal for **EGOLD+**, **Flash**, **MMG_ASIC** and **Display**
- Generation of 2.90 V via linear controller (REG_1)
- Generation of 2.00 V via linear controller (REG_2)
- Generation of 2.65 V via linear controller (REG_3)
- Generation of 2.00 V via linear controller (LPREG)
- Analog switches
 7. SIM Switch
 7. LIGHT Switch
 7. IRDA Switch
 7. VSPG_Teiler Switch
- Battery charge support:
 1. Normal charging
 2. Trickle charging, if the battery voltage is below 3,2 V.
- Timer generation

All internal timers and pulses are derived from a 900 kHz ± 10% internal oscillator. Responsible for the frequency stability is an external resistor (**R257**) (1%) at the RREF pin.
- Audio
 1. Audio amplifier
 2. Mono audio driver for internal loudspeaker
 3. Driver to generate ringer tones
 4. Key-click generator
- I²C bus for communication between EGOLD+ and Schalke-ASIC

Notes

Switch on timing overview

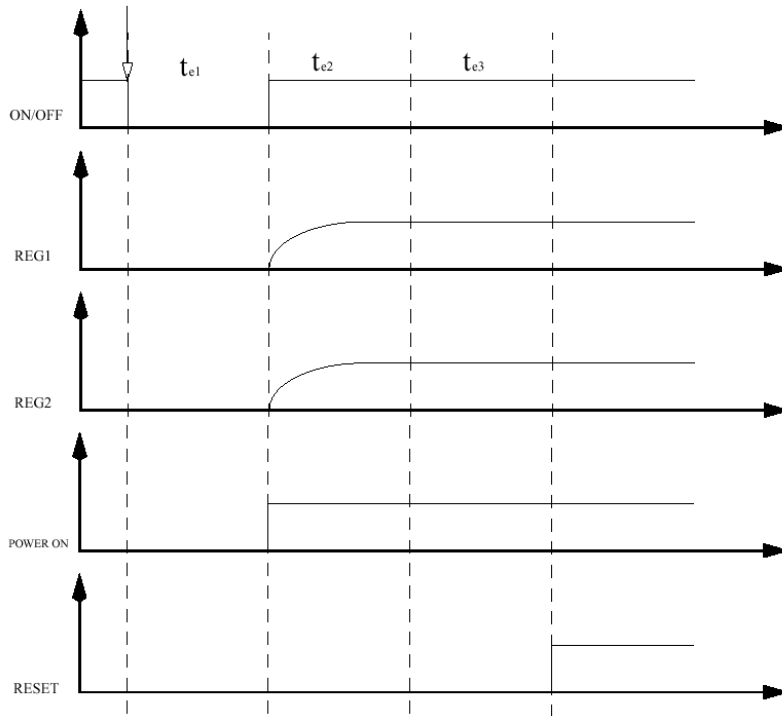

Switch off timing overview

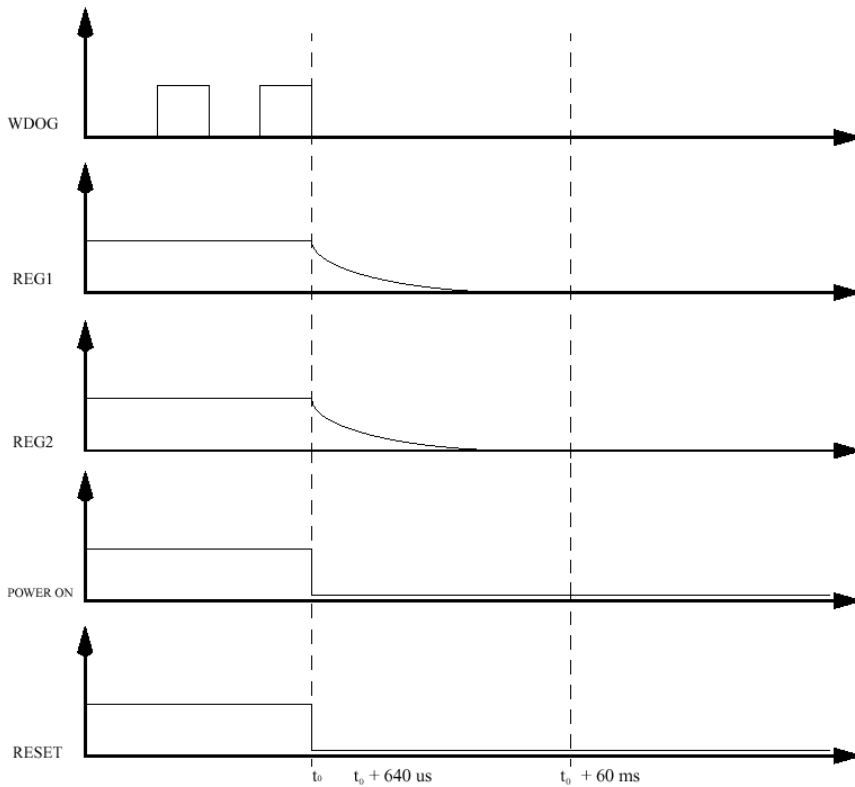

Battery

A Li-Ion battery with a nominal capacity of 540mAh is used for SL45.
A temperature sensor (NTC) is integrated to monitor the battery temperature.

Charging Concept

General

To control the charging process a charging control unit consists of a Fast Charge Controller and a Trickle Charger is implemented. Existing of a internal current source, a temperature monitoring, a external charge-FET, a charge detector (voltage level and/or charge current of an external charger supplied trickle charge circuit) and a detection of the charge current in 5 steps.
The charging control unit communication with the **EGOLD+** is done via the I²C bus.

- **CHARGE_μC**: charge request input of the **EGOLD+**
- **CHARGE**: Open Drain, -300...-600μA
- **TBAT**: comparator input for temperature sensor of the battery
- **REF_EXE**: Reference voltage for temperature sensor
- **VDD_CHARGE**: Charger typ detector input, power supply for trickle charge
- **SENSE_IN**: Voltage input of external current sensor (with reference to **AVDD**)

With rising slope on **CHARGE_μC** the current source is switched on via a LOW active **CHARGE** signal and the Charge-FET is conductive.

Condition:

- **CHARGE_μC** is HIGH for min. 20μs
- temperature sensor detects no overhead
- No overvoltage on **VDD**.

With falling slope on **CHARGE_μC** the current source is switched off and the Charge-FET is locked.

Temperature sensor works by T>60°C.

Fast charging

After connecting a charger and a battery voltage higher then 3,2 V the controller switches via a HIGH level of **CHARGE_μC** the charge-FET conductive, if the level of **TBAT** is > then the level of **REF_EXE**.

The charging current (and battery voltage) is controlled with the pulse duty factor of **CHARGE_μC**. The current flow can detected with the signal **SENCE_IN**, controlled via the I²C bus from the **EGOLD+**.

Trickle charge

If the phone has not been used for a longish time (longer than approx. 1 month), the battery could be totally self-discharged. (battery voltage less then 3,2V), so that it is not possible to charge the battery via the normal charging circuit. In this case only trickle charge is possible.

The **Schalke-ASIC** controls the charging circuit himself.

- Battery voltage below 2,8 Volt charging current 20mA.
- Battery voltage below 3,2 Volt charging current 50mA.
- Battery voltage over 3,2 Volt "Normal charging".

Power supply for the **Schalke-ASIC** in this mode is the external charger.

(**VDD_CHARGE**) This charging mode is not visible for the customer. IF the battery voltage reaches the 3,2V level the **Schalke-ASIC** switch into normal charge.

Notes.

Measurement of Battery and Ambient Temperature

The voltage equivalent of the temperature on the voltage divider is measured as the difference against a reference voltage of the **EGOLD+**. For this, the integrated $\Sigma\Delta$ converter of the **EGOLD+** of the RX-I base band branch is used. Via an analog multiplexer, either the RX-I base band signal, (the battery temperature Voltage) or the ambient temperature voltage can be switched to the input of the converter. The 1-Bit current of the converter will be subjected to a data reduction via the DSP circuit so that the measured voltage (for battery and ambient temperature) will be available at the end as a 10-bit data word.

Measurement of the Battery Voltage

Analog to the I-branch either the RX-Q base band signal or the battery voltage can be measured in the Q-branch. The processing in the DSP circuit is done similar to the I-branch. The **EGOLD+** is specified for voltages measurements at the input **pin N1** (VBAT) from 3V...5.5V.

Timing of the Battery Voltage Measurement

Unless the battery is going to be charged, the measurements are made in the TX time slot. While charging the measurement is done after the TX time slot. At the same time, either the battery temperature (in the I-branch) and the battery voltage (in the Q-branch) or the ambient temperature in the I-branch can be measured. Other combinations are not possible. For the time of the measurement the multiplexer in the **EGOLD+** must be programmed to the corresponding measurement.

Notes

5.3. Power Supply MP3 (LARA)

A voltage regulator (N490) with a nominal output voltage of 2.9V is used, to perform the required MP3 (LARA) voltage.

The voltage regulator N490 is activated via MP3 (LARA) _EN provided by the EGOLD+ (RF-Control L12).

The name of the voltages is 2V9_MP3 (LARA) activated by MP3 (LARA) _EN

For the voltage BATT+ is required.

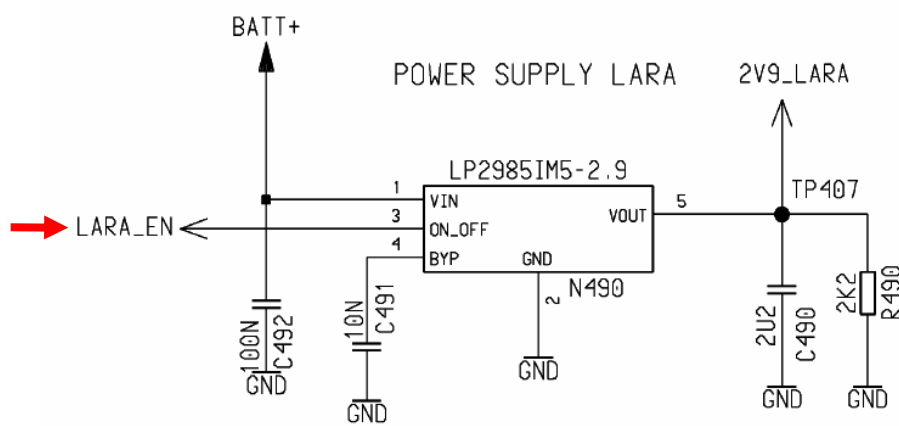

6.Logic Part

6.1. Overview Logic

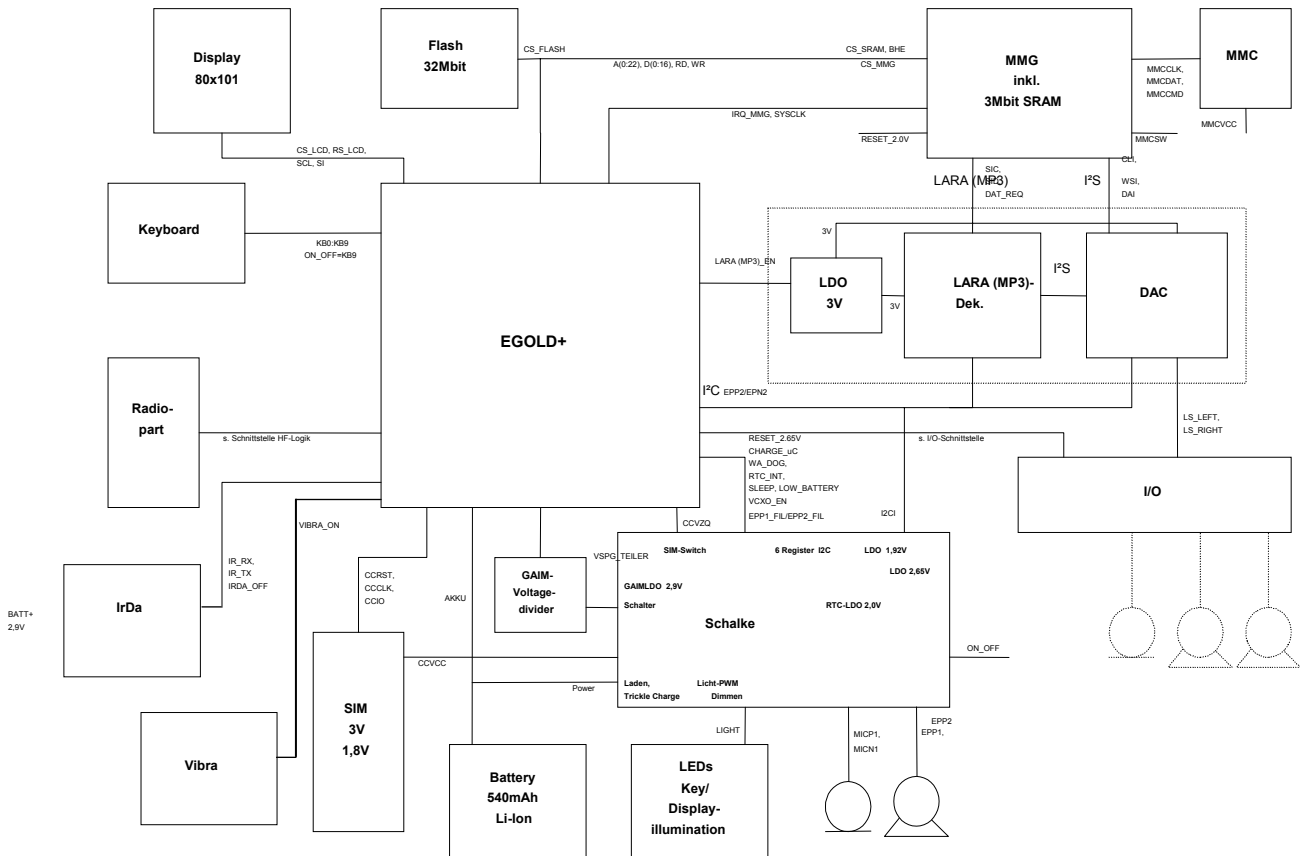

Vertraulich - Confidential

The μ C-part components

- Mikrocontroller
- Systeminterfaces for internal and external peripherals
- Onchip peripherals and memory chips

The Controller-Firmware:

- Controlling of the Man Machine Interface (Keypad, LCD, Illumination, ...)
- GSM Layer 1-3
- Controlling Radio part (Synthesizer, AGC, AFC, ...),
- Controlling of the Baseband part (EGAIM)

The SP-Part components

- DSP Signalprozessor

Die DSP-Firmware

- Equaliser
- Channel Coder
- Channel Decoder,
- Voice Encoder
- Voice Decoder

Notes

6.3. Overview EGAIM

Notes

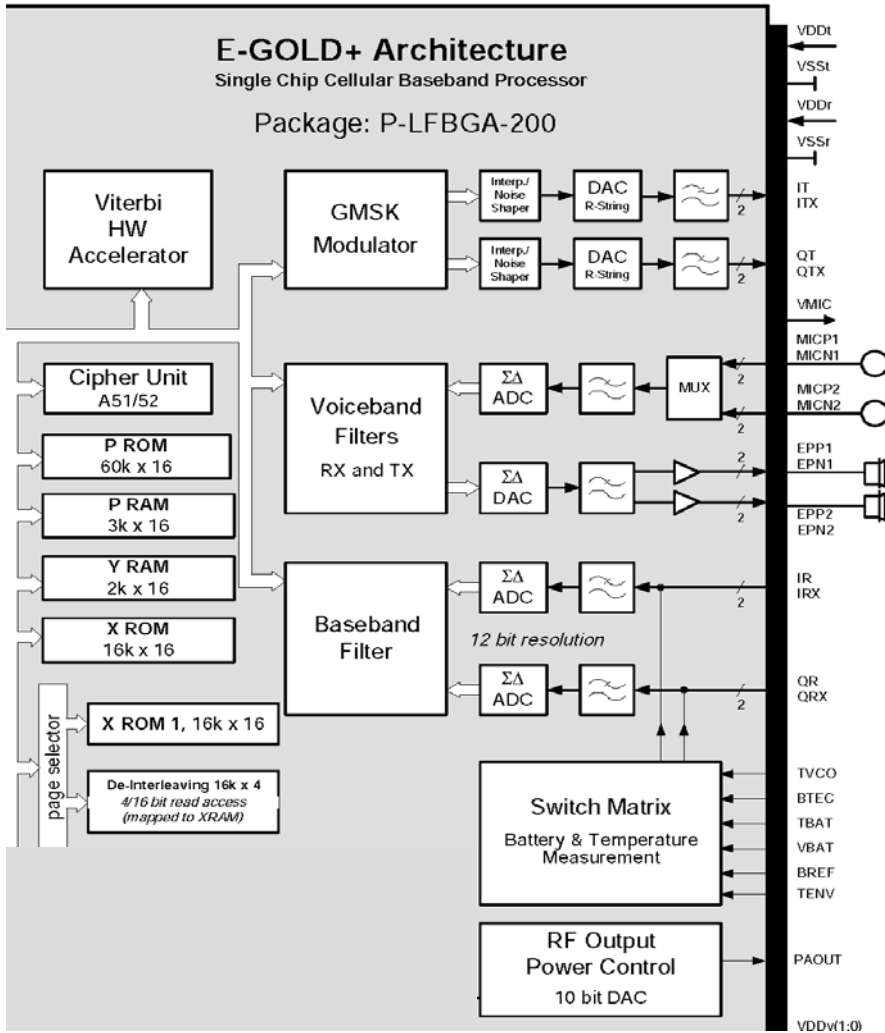

EGAIM inside the EGOLD+

This IC is the interface between digital and analogue signals.
EGAIM components

- 2 Sigma Delta A/D-converter for RX/Battery
- 2 D/A- converter for GMSK TX Inphase- und Quadratur signals,
- 1 D/A- converter for the Power Ramping signal,
- 1 Sigma Delta A/D- und D/A-converter for the voiceband part

a) Measurement of Battery and Ambient Temperature

The temperature is measured as a voltage equivalent of the temperature on the voltage dividers **R115,R116,R117** for the battery temperature and **R118,R119, R120** for the ambient temperature from the EGAIM.

For this, the integrated $\Sigma\Delta$ converter of the EGAIM of the RX-I base band branch is used. This $\Sigma\Delta$ converter compares the voltage of **TBAT** and **TENV** internally with a reference voltage **BREF**.

Via an analog multiplexer, either the RX-I base band signal, or the **TBAT** signal and the **TENV** signal can be switched to the input of the converter.

The signal **MEAS_ON** from the EGOLD+(**GSM TDMA-TIMER G11**) activates the measurement and is used to generate to **BREF** by the help of **R121,R122**

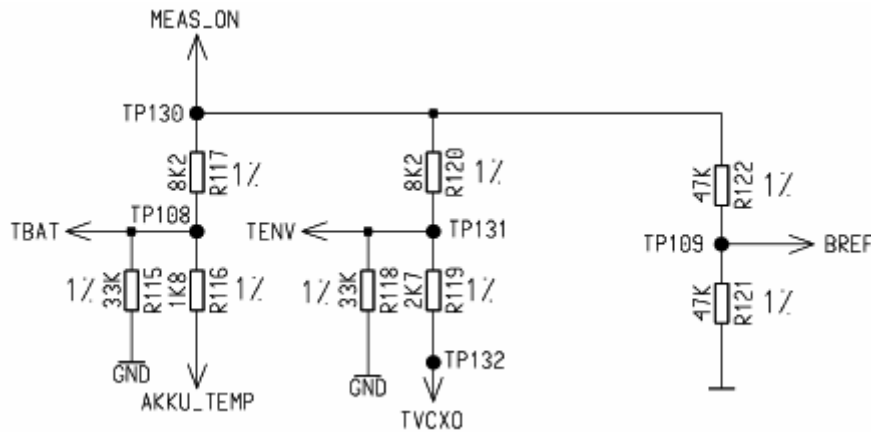

Notes

b) Measurement of the Battery Voltage

The measurement of the battery voltage is done in the Q-branch of the EGAIM. For this **BATT+** is connected via a voltage divider **R113, R114** to the EGOLD+ (**GAIM N2**) (Input limitation 1.33V to 5.91V) .An analog multiplexer does the switching between the baseband signal processing and the voltage measurement.

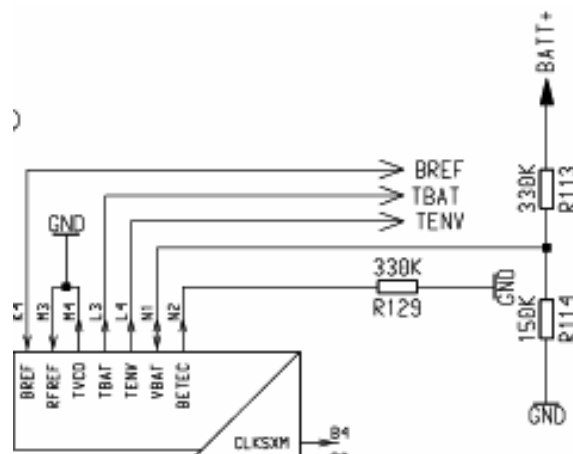

a) A/D conversion of MIC-Path signals incl. coding

The Microphone signals (**HF_MICRO**, **MICN2**, **MICP**, **MICN**) arrive at **Notes** the voiceband part of the EGAIM. For further operations the signals will be converted into digital information, filtered, coded and finally formed into the GMSK-Signal by the internal GMSK-Modulator. This so generated signals (**IT**, **ITX**, **QT**, **QTX**) are given to the SMARI IC (pins 9-12) in the transmitter path.

b) D/A conversion of EP-Path signals incl. decoding

Arriving at the Baseband-Part the demodulated signals (**RX_I**, **RX_IX**, **RX_Q**, **RX_QX**) will be filtered and A/D converted. In the voiceband part after decoding (with help of the uC part) and filtering the signals will be D/A converted amplified and given as (**EPP1**, **EPN1**, **EPP2**, **EPN2**) to the internal earpiece or the external loudspeaker.

c) Generation of the PA Control Signal (PA_RAMP)

The RF output power amplifier needs an analog ramp up/down control voltage. For this the system interface on EGOLD+ generates 10 bit digital values which have to be transferred serially to the power ramping path. After loading into an 10 bit latch the control value will be converted into the corresponding analog voltage with a maximum of ~2V

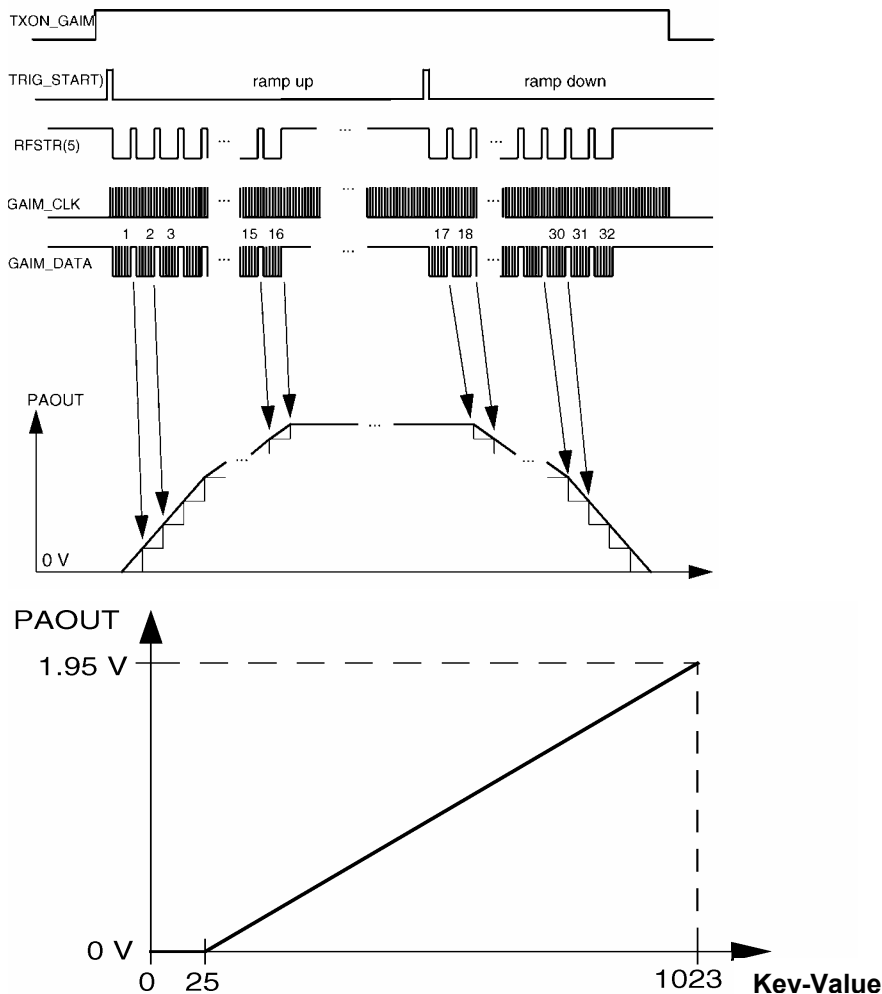

6.4. Overview MMG ASIC

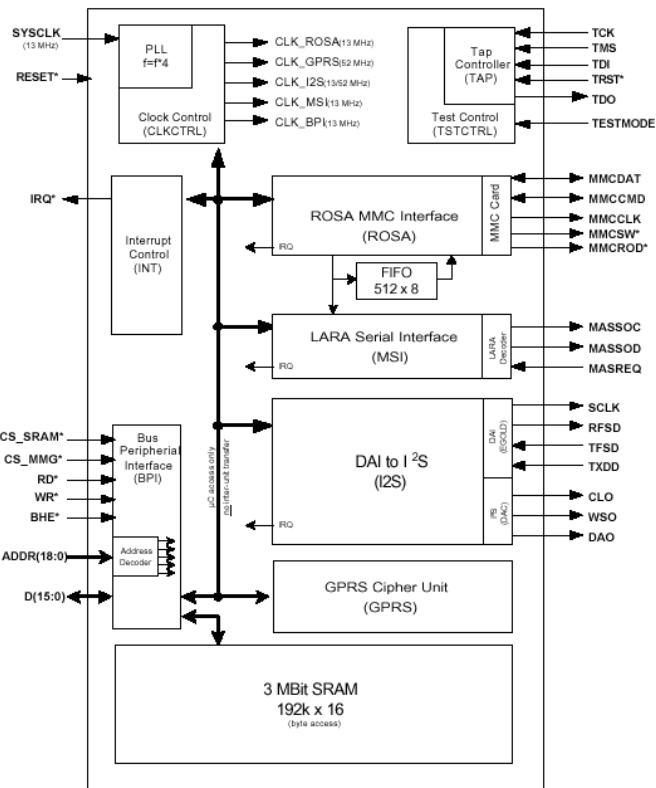

MMG-ASIC components

- Frequency generation
The PLL generates a 52MHz signal based on the 13MHz- (output CLK_SXM EGOLD+). The signal is the reference of all Clock and Timing signals of the ASIC.
- I²S-Interface:
The interface modulate the data of the DAI-Interfaces (EGOLD+) into a I²S-data format, used for the input of the stereo-D/A-converter in the DAC3550.
- MP3 (LARA) - Interface:
Generate a MP3 (LARA) -data current. Conversation of parallel-/serial data of the 16bit-parallelbus
- MMC-Interface:
Access to the MMC via serial HW-Interface. Control commands and data transmission from and to the EGOLD+.
- 3MBit SRAM:
SRAM implemented for write and read access.

Notes

6.5. MP3 (LARA) HW components

- DAC3550

Stereo-D/A-converter analogue - multiplexer are inside, for speech and MP3 (LARA) output. (not simultaneously). Loudness level adjusted via I²C.

Notes

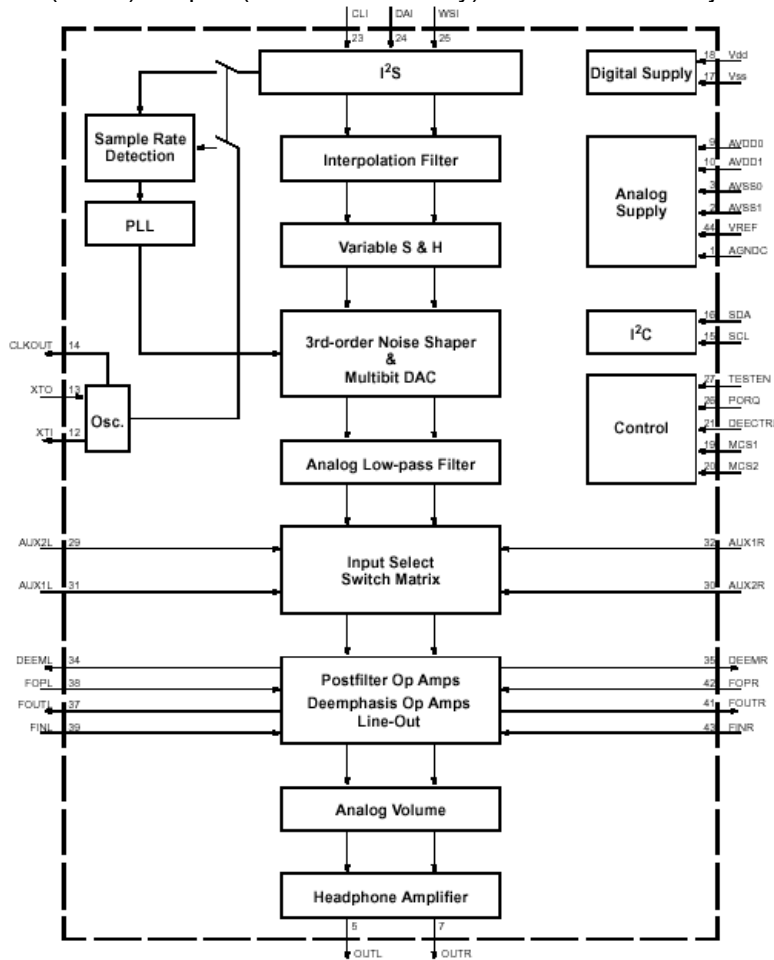

- MAS3507

Decoding off MP3 (LARA) data

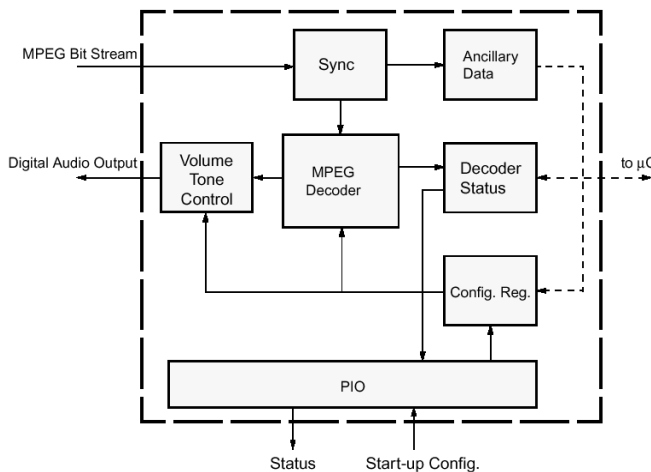

6.6. FLASH memory

Non volatile, but erasable and re-programmable (Software-Update) memory chip of the EGOLD+, also to save user data (menu settings), Voice Memo, adjustment values

Notes

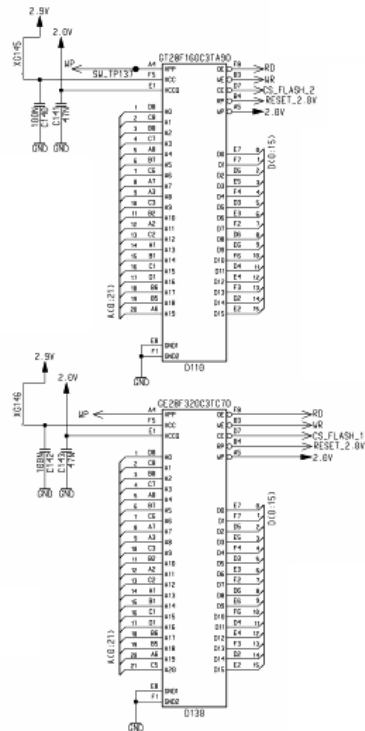

6.7. Real time clock inside the EGOLD+

Real time clock, supplied from a voltage regulator inside the Schalke-ASIC. Also active when mobile phone is switched off. During battery change a capacitor (C258) as power supply is used for minimum 30 sec to save the stored data.

6.8. IrDA

Infrared diode for data transfer to standard IrDa devices.

The vibrator is activated by the transistor V290 via the Signal **Vibra_on** from **EGOLD+**. **Batt+** is required to provide the VIBRA. The diode V292 is used to protect the circuit against over voltage and switching spikes.

Notes

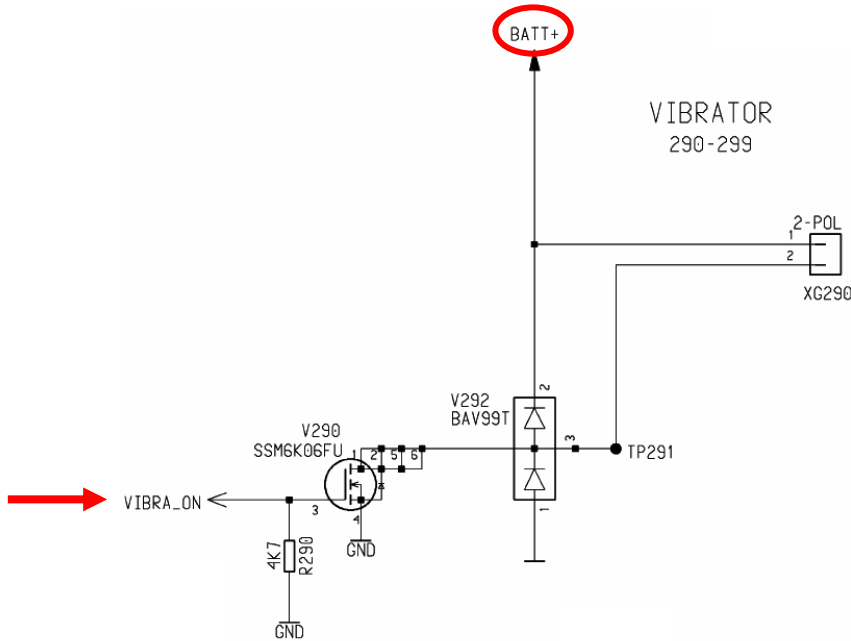

7.3. Microphone

Both Microphones are direct connected to the **EGOLD+**.(Voiceband F1-F4) via the signals **MICN1**, **MICP1** (Internal Microphone)and **MICN2**, **MICP2** (External Microphone/Headset). Power supply for the Microphone is **VMIC** (Voiceband E1)

Internal Microphone

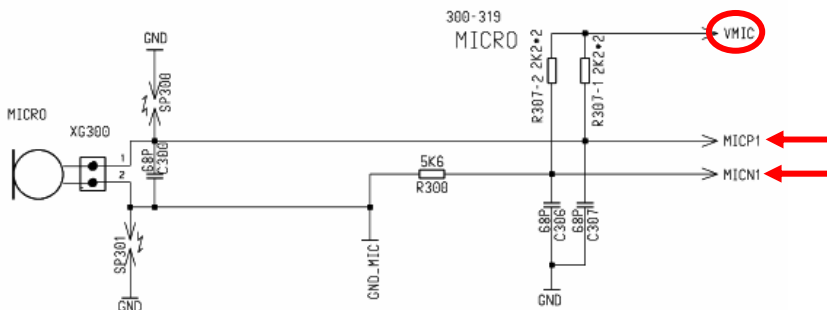

The SL45 has no ringer component. Responsible for the audio output of the ringer tones is the loudspeaker. The ringer tones are generated by a signal **RINGIN** from the **EGOLD+** (**Miscellaneous M11**). This signal goes to the mono audio amplifier inside the Schalke-ASIC.

Notes

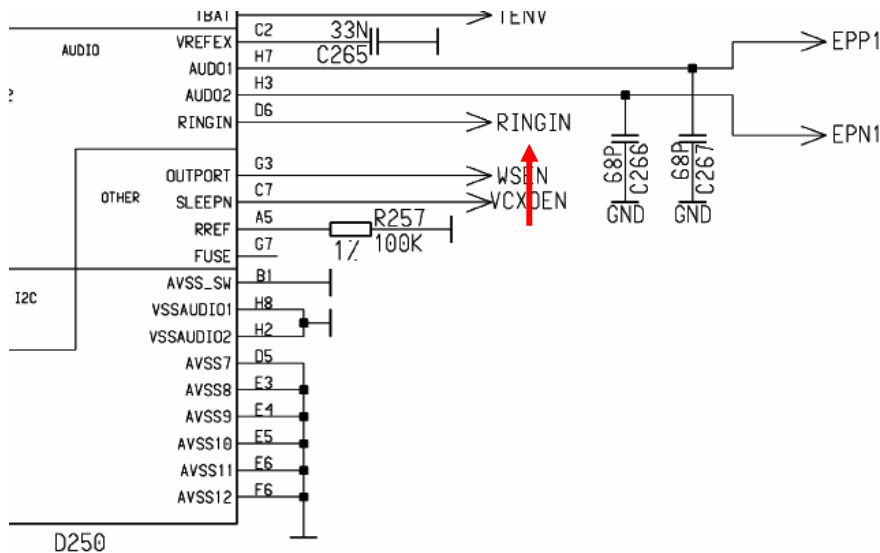
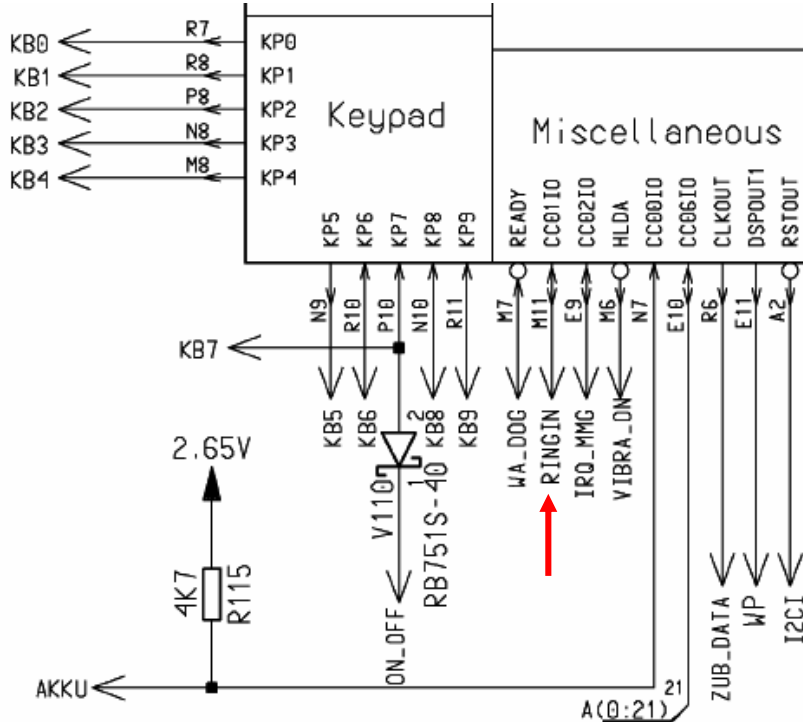

8. Illumination and keyboard:

8.1. Illumination

The Light is switched via an analogue switch inside the **Schalke-ASIC**. It is controlled from the **EGOLD+** with the signal **LIGHT_OFF**. Output is the signal **LIGHT** which is connected via the MMI connector the LEDs.

Notes

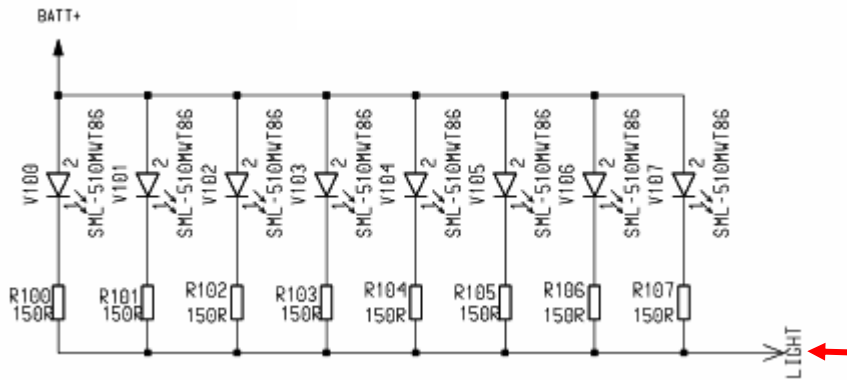
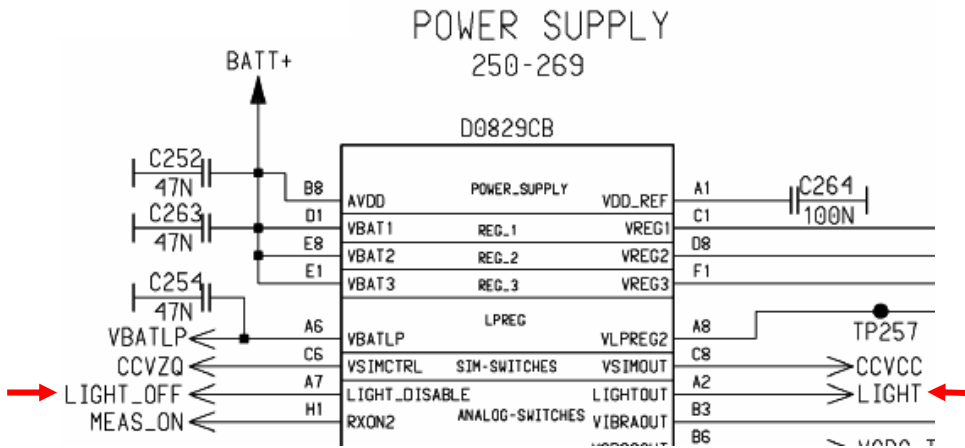

8.2. Keyboard

The keyboard lines are via MMI connector linked to the **EGOLD+** (Keyboard R7/R8/P8/N8/M8/N9/R10/P10/N10/R11). KB (keyboard line) 0 to 5 are outputs, KB 6 to 9 inputs. To make a short cut from an output to an input line with the keypad the **EGOLD+** registered with key is pressed.

Notes

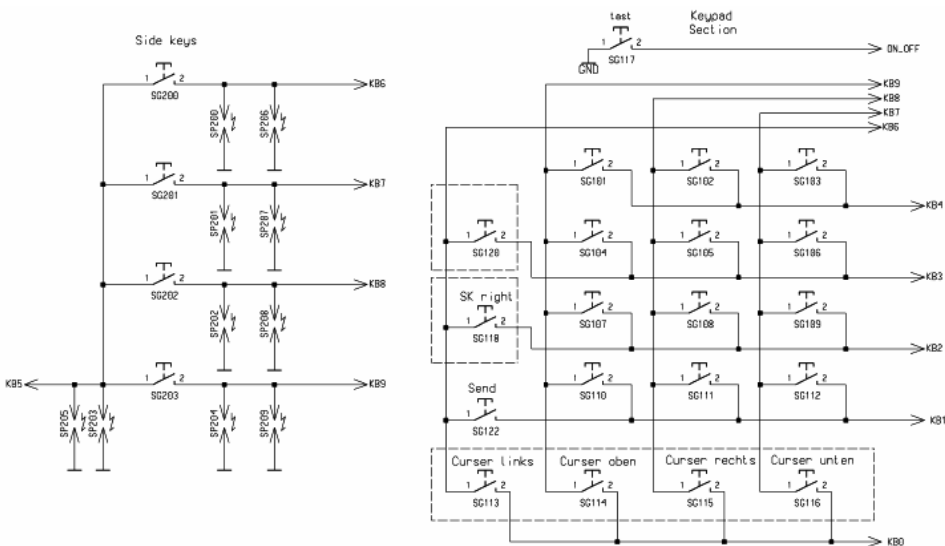

9. Connectors

9.1 I/O connector

Pin	Name	IN/OUT	Notes
1	GND		
2	HS_LEFT	I/O	Output left channel for stereo-headset.
3	POWER	I	Charging Current
4	FBatt+	O	Power supply for the accessories.
5	TX	O	Serial interface
6	RX	I	Serial interface
7	ZUB_CLK	I/O	Clock line for accessory bus Use as DTC In data operation
8	ZUB_DATA	I/O	Data line for accessory bus. Use as CTS in data operation
9	GND_MIC		For external microphone
10	MICP2	I	External microphone
11	HS_RIGHT	O	Output right channel for stereo-headset
12	LGND		For external loudspeaker

Notes

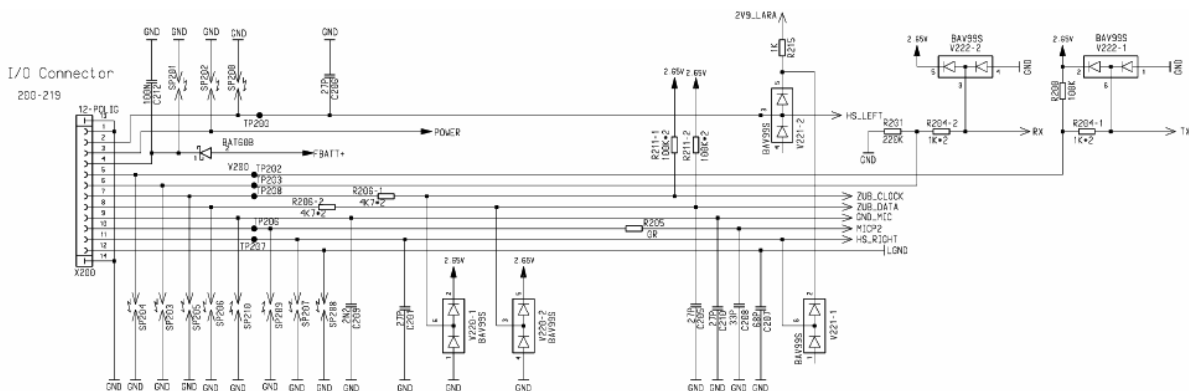

9.2 Battery connector

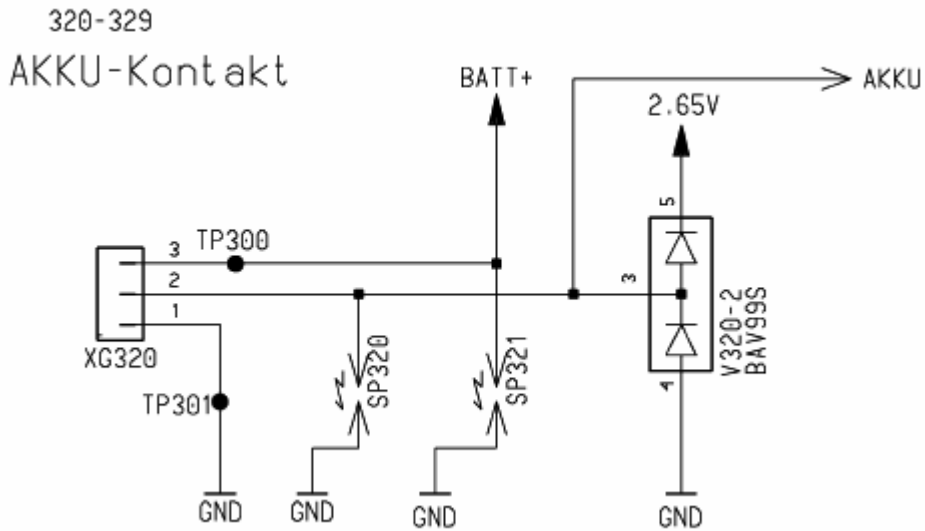

Pin	Name	IN/OUT	Notes
1	GND		
2	Akku_Temp	O	Temperature control of the battery pack.
3	POWER +	I/O	Battery voltage

9.3 Display connector

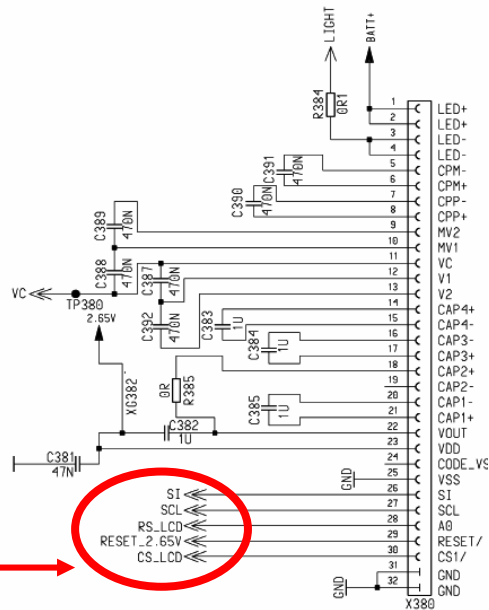

Connection Egold+ to Display-Controller

9.4 MMI connector

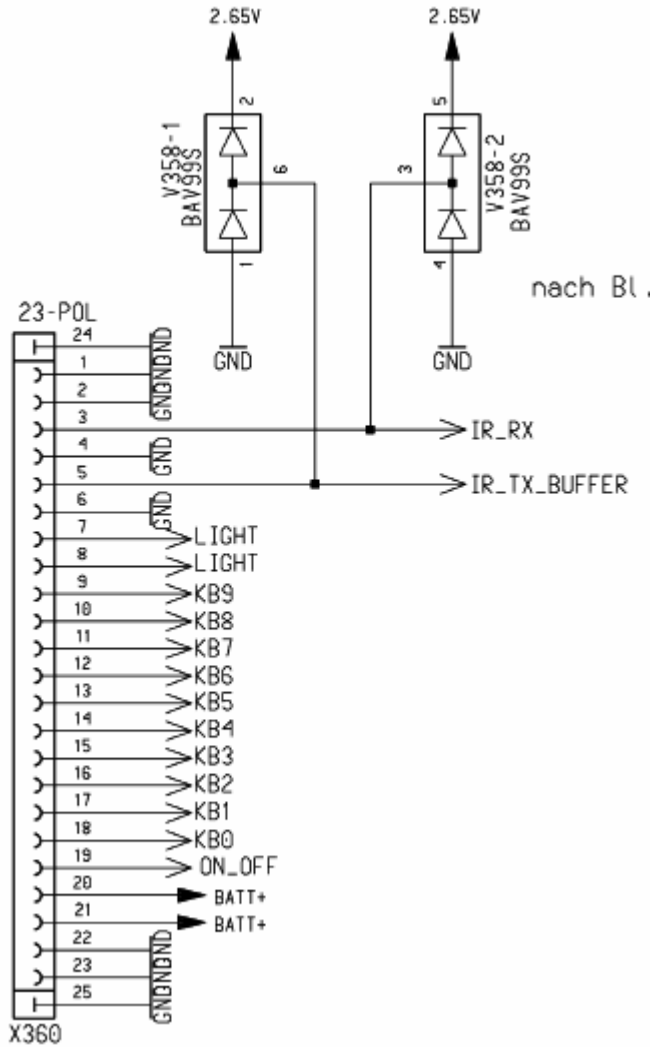

Function	Names
ILLUMINATION	Light
KEYBOARD	KB0 – KB9 / ON_OFF
IrDA INTERACE	IR_RX / IR/TX_BUFFER
BATTERY VOLTAGE	BATT+