



MARITIME GEOTHERMAL LTD.



Installation and Service Manual

EMW-Series
Two-Stage R410a
Model Sizes 45-80

Energy Module Hydronic Geothermal Heat Pumps



Maritime Geothermal Ltd.
P.O. Box 2555
Petitcodiac, N.B. E4Z 6H4
Ph. (506) 756-8135

Email: info@nordicghp.com
Web: www.nordicghp.com
Document Number: 000647MAN-03



SAFETY PRECAUTIONS



WARNING: Ensure all access panels are in place and properly secured before applying power to the unit. Failure to do so may cause risk of electrical shock.

WARNING: Before performing service or maintenance on the heat pump system, ensure all power sources are DISCONNECTED. Electrical shock can cause serious personal injury or death.

WARNING: Heat pump systems contain refrigerant under high pressure and as such can be hazardous to work on. Only qualified service personnel should install, repair, or service the heat pump.

CAUTION: Safety glasses and work gloves should be worn at all times whenever a heat pump is serviced. A fire extinguisher and proper ventilation should be present whenever brazing is performed.

CAUTION: Venting refrigerant to atmosphere is illegal. A proper refrigerant recovery system must be employed whenever repairs require removal of refrigerant from the heat pump.

MODEL NOMENCLATURE

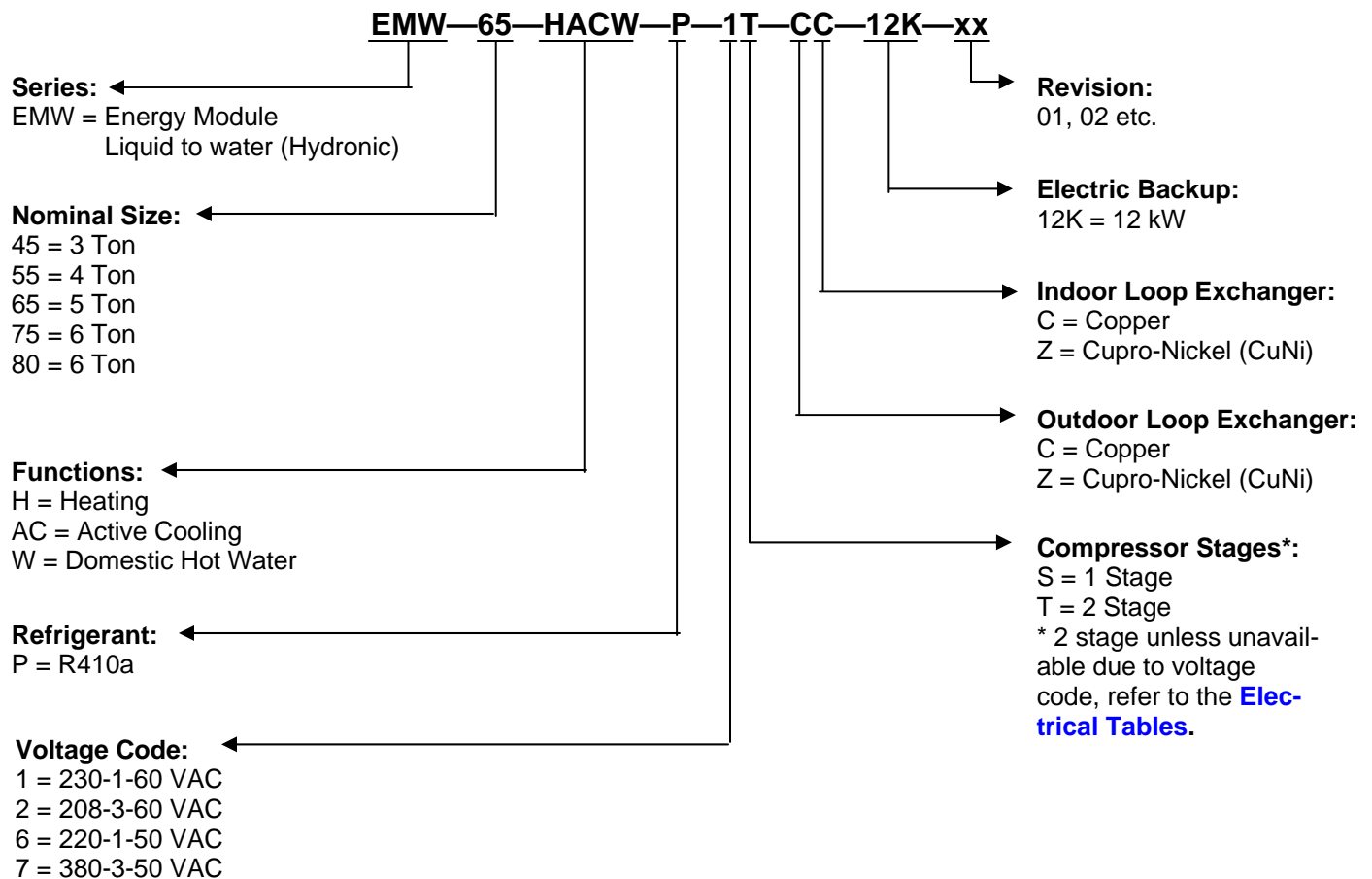

APPLICATION TABLE

SIZE	FUNCTION	REFRIGERANT	VOLTAGE	STAGES	OUTDOOR COIL	INDOOR COIL	ELECTRIC	REVISIONS				
45	HACW	P	1	T	C or Z	C or Z	12K	05				
			2	T				05				
			6	T				05				
			7	T				05				
55	HACW	P	1	T	C or Z	C or Z	12K	05				
			2	T				05				
			6	T				05				
			7	T				05				
65	HACW	P	1	T	C or Z	C or Z	12K	05				
			2	T				05				
			6	T				05				
			7	T				05				
75	HACW	P	1	T	C or Z	C or Z	12K	05				
			2	T				05				
			6	S				05				
			7	T				05				
80	HACW	P	1	S	C or Z	C or Z	12K	05				
			2	S				05				
			7	S				05				

This manual applies only to the models and revisions listed in this table

Table of Contents

INSTALLATION INFORMATION:	PAGE 6
Unit description:	Page 6
Unpacking the unit:	Page 6
Optimum Placement:	Page 6
Electrical Connections:	Page 6
Circulator Pump Module Wiring (Ground Loop Only):	Page 6
Control Requirements:	Page 6
Control Transformer :	Page 7
Safety Controls:	Page 7
Indicator Lights:	Page 8
Loop Terminology:	Page 8
Internal Hydronic Components:	Page 8
Electric Heat:	Page 8
Zone Connections:	Page 8
Purging the Indoor System:	Page 8
Domestic Hot Water Connections:	Page 9
SIZING AND HYDRONIC INFORMATION:	PAGE 13
Heat Pump Sizing:	Page 13
Hydronic Applications General:	Page 13
GROUND WATER SYSTEM INFORMATION:	PAGE 15
General Requirements:	Page 15
Plumbing the Heat Pump:	Page 15
Pipe Insulation:	Page 15
Water Discharge Methods:	Page 15
GROUND LOOP SYSTEM INFORMATION:	PAGE 18
Circulator Pump Module:	Page 18
Flushing & Purging the Ground Loop:	Page 18
Adding Antifreeze Solution:	Page 19
Initial Pressurization:	Page 19
Pipe Insulation:	Page 19
STARTUP PROCEDURE:	Page 21
Pre-start Inspection:	Page 21
Unit Startup:	Page 22
Startup Record:	Page 23
GENERAL MAINTENANCE:	PAGE 24
TROUBLESHOOTING GUIDE:	PAGE 25
Repair Procedures:	Page 34
Refrigeration Circuit Diagrams:	Page 35
MODEL SPECIFIC INFORMATION:	PAGE 37
Refrigerant Charge Chart:	Page 37
Standard Capacity Ratings:	Page 37
Capacity Ratings:	Page 39
Electrical Tables:	Page 44
Electrical Diagrams (230-1-60):	Page 45
Case Details:	Page 47
APPENDIX A: Control Board Specifications:	PAGE 48
WARRANTY INFORMATION:	PAGE 52

Tables, Diagrams and Drawings

TABLES

Table 1 - Control Signal Description:	Page 6
Table 2 - Typical Aquastat Settings:	Page 7
Table 3 - Control Board Fault Codes:	Page 7
Table 4 - Indicator Lights:	Page 8
Table 5 - Heat Pump Size vs. Heated Area for Ground Loop Systems:	Page 13
Table 6 - Heat Pump Size vs. Heated Area for Ground Water Systems:	Page 13
Table 7 - Required Flow and Air Bladder Tank Sizing:	Page 15
Table 8 - Antifreeze Percentages by Volume:	Page 19
Table 9 - Volume of Fluid per 100ft. Of Pipe:	Page 19
Table 10 - Refrigerant Charge Chart:	Page 37
Table 11 - Shipping Information:	Page 37
Table 12 - Standard Capacity Ratings - Ground Loop Heating 60Hz:	Page 37
Table 13 - Standard Capacity Ratings - Ground Water Heating 60Hz:	Page 37
Table 14 - Standard Capacity Ratings - Ground Loop Cooling 60Hz:	Page 38
Table 15 - Standard Capacity Ratings - Ground Water Cooling 60Hz:	Page 38
Table 16 - Heat Pump Electrical Information (230-1-60):	Page 44
Table 17 - Heat Pump Electrical Information (208-3-60):	Page 44
Table 18 - Heat Pump Electrical Information (220-1-50):	Page 44
Table 19 - Heat Pump Electrical Information (380-3-50):	Page 44

DIAGRAMS

Diagram A - B&G NRF-36 Pump Curve:	Page 8
Diagram B - Circulator and Major Component Locations:	Page 9
Diagram C - Typical P/T (Pete's) Plug & Thermometer Stem:	Page 18
Diagram D - Typical Purge Cart:	Page 18

DRAWINGS

000531CDG - Typical Heating Only Zone Wiring Diagram (EM-Series):	Page 10
000583CDG - Typical Heating and Cooling Zone Wiring Diagram (EM-Series):	Page 11
000970PDG - Single Unit Connection to DHW Pre-Heat Tank (Brass FPT):	Page 12
000530PDG - Typical Zone Types for Hydronic Applications:	Page 14
000907CDG - Typical Ground Water Installation for Size 25-75 Heat Pumps (Brass FPT):	Page 16
000619INF - Ground Water Disposal Methods:	Page 17
000906CDG - Geo-Flo Circulator Pump Module Installation (Brass FPT):	Page 20
001047RCD - EMW-HAC* Series Refrigeration Circuit Diagram—Heating Mode:	Page 36
001048RCD - EMW-HAC* Series Refrigeration Circuit Diagram—Cooling Mode:	Page 37
000448SCH - EMW**-HAC*-1T-**-*** Schematic Diagram:	Page 48
000449ELB - EMW**-HAC*-1T-**-*** Electrical Box Diagram:	Page 49

Installation Information

UNIT DESCRIPTION

The EMW-Series unit is a high efficiency R410a refrigerant two-stage geothermal heat pump with built in buffer tank, zone circulator, expansion tank, valves and gauges, and controls. It is a compact stand alone modular system that greatly reduces installation time and space.

The unit has several key features that are described in the specifications document for the particular heat pump. Please request a copy if desired or visit www.nordicghp.com

UNPACKING THE UNIT

When the heat pump reaches its destination it should be unpacked to determine if any damage has occurred during shipment. Any visible damage should be noted on the carrier's freight bill and a suitable claim filed at once.

The heat pump is well constructed and every effort has been made to ensure that it will arrive intact, however it is in the customer's best interest to examine the unit thoroughly when it arrives.

OPTIMUM PLACEMENT

The placement of a hydronic unit has negligible effects on the operation of the system. For ground water systems, the unit can be placed near the well water system, ground loop system units can be placed near where the header pipes enter the structure to keep the ground loop piping, heat pump and circulator pump module in one location. The hydronic layout may make a particular location ideal for the unit installation.

If possible the access panels should remain clear of obstruction for a distance of **two feet** to facilitate servicing and general maintenance.

Raising the heat pump off the floor a few inches is generally a good practice since this will prevent rusting of the bottom panel of the unit. We recommend that the heat pump be placed on a piece of 2" Styrofoam covered with 1/4" plywood. The Styrofoam will smooth out any irregularities in the cement floor while the plywood will distribute the weight of the unit evenly over the Styrofoam. This process will also deaden the compressor noise emitted from the bottom of the cabinet.

ELECTRICAL CONNECTIONS

The heat pump has a concentric 1.093" / 0.875" knockout for power supply connection to the electrical box. There are also two other 0.875" knockouts: one for connections to the indoor circulator; the other for connections to the circulator pump module for ground loop applications. There are three 1/2" openings with plastic grommets (grommet hole is 3/8") in the upper section of the electrical box for connections to the controls.

A schematic diagram and electrical box layout diagram (ELB) can be found inside the electrical box cover of the unit as well as in the [Model Specific](#) section of this manual. The Electrical Tables in the [Model Specific](#) section and the ELB diagram contain information about the size of wire for the connections, as well as the recommended breaker size.

A properly qualified electrician should be retained to make the connections to the heat pump and associated controls. The connections to the heat pump MUST CONFORM TO LOCAL CODES.

CIRCULATOR PUMP MODULE WIRING (GROUND LOOP ONLY)

The heat pump has provisions for connecting the circulator pump module so that the pumps will be turned on whenever the compressor operates. Connect the circulator pump module to the appropriate two terminals of the terminal strip marked **OUTDOOR CIRCULATORS** in the heat pump, as per the voltage of the circulator pump module. Ensure that the total current draw of all circulators connected to the terminal strip does not exceed the value indicated on the label in the heat pump electrical box. Refer to the electrical box drawing on the electrical box cover for more information.

CONTROL REQUIREMENTS

The heat pump comes equipped with a two-stage heating aquastat (and two stage cooling for reversing units). The stages are S1 = Stage 1 compressor, and S2 = Stage 2 compressor, as well as auxiliary heat on a 0-2 hour timer. The EMW unit operation is self sufficient, the only control signals required are to turn on the Zone Circulator(s) located inside the unit, and to switch to cooling mode for reversing units.

The electrical box diagram on the electrical box cover provides a description of the signal connections in the heat pump. They are also listed in **TABLE 1** below.

TABLE 1 - Control Signal Description	
Signal	Description
C	24VAC Common (Ground)
R	24VAC Hot
Z	Zone Circulator
O	Cooling Mode (reversing valve)*

* Reversing units only

The zone circulator is activated by connecting R and Z together via dry contacts. The unit can be switched to cooling mode by connecting R and O together via dry contacts. Dry contacts are used for all heat pump connections to ensure that the heat pump control signals remain isolated from the rest of the system.

Heating/cooling systems should have a method to disable radiant in-floor heating zones while in cooling mode to prevent condensation on the floor. [Drawing 000531CDG](#) show a typical wiring diagram for a heating only setup, while [drawing 000583CDG](#) depicts a heating/ cooling wiring diagram. These drawings represent a basic system, in which heating is the default mode and cooling has priority. It is recommended that the system be designed by a qualified system designer to ensure proper functionality.

TABLE 2 shows typical settings for the aquastats. With these settings, Stage 1 will activate when the tank temperature reaches the activation point. If the load is too great, the tank temperature will continue to drop when heating (rise when cooling) until Stage 2 is activated. As the tank temperature stops dropping and begins to increase when heating (decrease when cooling), Stage 2 will turn off before Stage 1, rather than at the same time as Stage 1. There are three main advantages to this:

- Less aquastat probe lag leading to reduced overshoot as the

tank temperature rate of change is reduced when only Stage 1 is active.

- Prolonged Stage 1 runtime leads to increased overall efficiency as Stage 1 has a higher COP than Stage 2.
- Reduced number of compressor starts.

The settings may be changed as desired; however Stage 1 setpoint for heating should not exceed **120°F (49°C)**; Stage 1 cooling setpoint should not be set below **43°F (6°C)**. Exceeding these setpoint limits will cause the heat pump operating pressures to approach the safety control settings, possibly causing nuisance shut downs.

TABLE 2 - Typical Aquastat Settings				
HEATING AQUASTAT				
	Stage 1		Stage 2	
Item	°F	°C	°F	°C
Setpoint	105	41	100	38
Delta	8	4	8	4
Activation *	97	37	92	34
COOLING AQUASTAT (Reversing units only)				
	Stage 1		Stage 2	
Item	°F	°C	°F	°C
Setpoint	45	7	50	10
Delta	8	4	8	4
Activation *	53	11	58	14
*Activation is indirectly set by the Setpoint and Delta values				

If fan coils are being heated, it may be required to increase the heating setpoints by 10°F (6°C) in order to obtain the required heating capacity.

CONTROL TRANSFORMER

The low voltage controls for 208/230-1-60 and 208-3-60 models are powered by a 100VA class II transformer. The transformer has a resettable breaker on the secondary side for circuit protection. Should the breaker trip, locate and correct the problem and then reset the breaker by pressing in on it.

NOTE: For 208/230VAC-1-60 units, if connecting to 208VAC power supply move the red wire connected to the 240 terminal of the transformer to the 208 terminal of the transformer.

The low voltage controls for 220-1-50 and 380-3-50 models are powered by a 100VA class II transformer with primary and secondary fuses. Should a fuse blow, locate and correct the problem then replace the fuse.

SAFETY CONTROLS

The heat pump has two built in safety controls which are designed to protect the unit from situations which could damage it should the operation of the refrigeration circuit fall outside the allowable operating range.

A. Low Pressure Control

The low pressure control monitors the compressor suction pressure and will shut the compressor down if the refrigerant evaporating pressure becomes too low, risking the danger of freezing conditions in the evaporator.

There are (3) main reasons why this control would activate in response to the operating conditions of the unit while operating in heating mode:

1. Low or no outdoor loop flow.
2. Low Outdoor loop entering liquid temperature.
3. Dirty or fouled Outdoor loop heat exchanger.

B. High Pressure Control

The high pressure safety control monitors the compressor discharge pressure and will shut the compressor down if the condensing pressure becomes too high.

There are (3) main reasons why this control would activate in response to the operating conditions of the unit while operating in heating mode:

1. Low or no Indoor loop flow.
2. High Indoor loop entering liquid temperature.
3. Dirty or fouled Indoor loop heat exchanger.

The unit contains a control board that monitors the safety controls and operates the compressor accordingly. Refer to **APPENDIX A** for control board specifications. The low pressure control is connected to LP1 and LP2. The high pressure control is connected to HP1 and HP2.

The control board also has provisions for a flow switch. The flow switch is unused from the factory and a jumper wire is placed across the FLOW SWITCH terminals. If a flow switch is desired, the jumper can be removed and the two leads from the flow switch can be connected to the FLOW SWITCH terminals on the safety board. The flow switch is ignored for 30 seconds on compressor startup to allow time for flow to be established. The high and low pressure controls are monitored at all times, the compressor will not be able to start if either of them has a fault.

The control board has an on-board LED and a FAULT pin with a 24VAC output. An external indicator or relay can be connected across the FAULT pin and ground if external signaling is desired. Should a fault occur, the LED will flash the code of the fault condition while the safety control in question is open. The codes are shown in **TABLE 3**. The control board will lock out the compressor for five minutes when a fault occurs. Three retries per fault condition are allowed within a 60 minute period.

If the fault condition occurs a fourth time the control board will permanently lock out the compressor and energize the FAULT pin. This can only be reset by powering down the unit. The LED will flash the fault code until the unit is reset.

TABLE 3 - Control Board Fault Codes	
Fault	Code
High Pressure	1
Low Pressure	2
Flow	3

If the control board enters permanent lockout mode there is a serious problem with the system and it must be rectified if the unit is to maintain good service.



WARNING: REPEATED RESETS OF A LOW PRESSURE LOCKOUT COULD CAUSE THE HEAT EXCHANGER TO FREEZE AND RUPTURE, DESTROYING THE HEAT PUMP AND VOIDING THE WARRANTY.

INDICATOR LIGHTS

The EMW-Series unit has three indicator lights on the side of the electrical box. They are described in **TABLE 4**.

TABLE 4 - Indicator Lights	
Colour	Indicates
Green	Compressor ON
Yellow	Electric Elements ON
Red	Trouble (Locked out)

LOOP TERMINOLOGY

The following terms are used to describe the various "loops" of the EMW heat pump system:

- Outdoor Loop—Connections for the ground loop exchanger or ground water system.
- Zone Loop—Connections for building heating/cooling loop. The Zone Circulator provides flow for this loop.
- Indoor Loop—Water loop between the condenser/evaporator and buffer tank.
- DHW Loop—Connections for the Domestic Hot Water.

INTERNAL HYDRONIC COMPONENTS

The EMW-Series unit has virtually everything typically required for a hydronic installation built into it, including the following:

- 50 USGAL (189L) buffer tank with electric backup
- Pre-charged expansion tank
- 125PSIG pressure relief valve
- Zone Circulator (B&G NRF-36) with isolation valves
- Pressure gauges
- Shutoff valves and boiler drains for purging
- Aquastat(s)

Refer to **Diagram B** for the locations of the components. The pump curve for the Zone Circulator is shown in **Diagram A**.

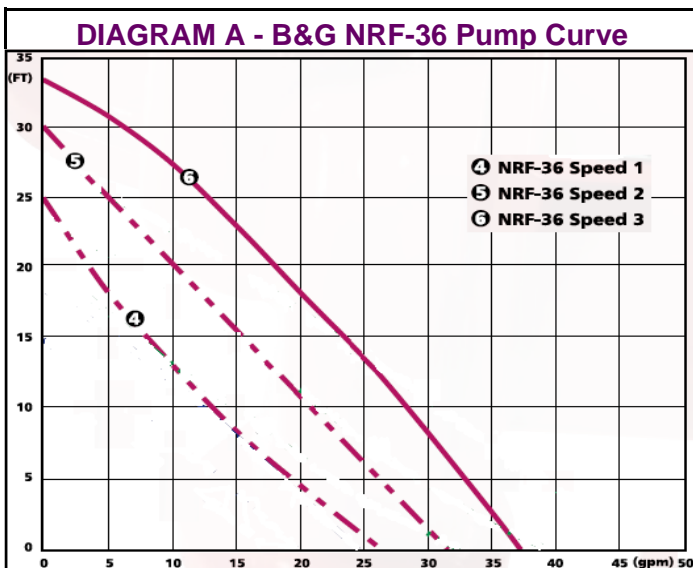

ELECTRIC HEAT

The buffer tank contains electric elements for the purpose of auxiliary / backup heat. The control for the electric heat comes from the Heating Aquastat Stage 2 signal. The signal passes through a 0– 2H timer before reaching the electric heat contactor coil. The timer is set to 1H (one hour) at the factory.

The unit is shipped with the electric heat breaker in the off position. **IT IS VERY IMPORTANT THAT THE INDOOR LOOP IS FLOODED AND PRESSURIZED BEFORE TURNING ON THE ELECTRIC HEAT BREAKER.** An electric element that is not under water will burn out in a matter of seconds.

There is a safety pressure switch mounted to the side of the buffer tank, **the electric heat contactor will not engage unless the pressure in the indoor loop is above 10PSIG.** Should the heat pump require service, the compressor breaker should be turned off. This prevents the refrigeration section from operating but allows the electric heat to continue operating.

ZONE CONNECTIONS

The Zone ports are 1" FPT brass fittings (refer to **CASE DETAILS**). The zone header pipes can be connected to these ports. It is recommended that unions or another type of disconnect be installed to facilitate heat exchanger cleaning should it be required. The Zone Circulator is activated by connecting R and Z together via dry contacts.

PURGING THE INDOOR SYSTEM

There are ball valves and boiler drains inside the unit to facilitate filling and purging. Once the system has been filled with the desired fluid, purging may be done in the following manner:

1. Connect a fill hose to the Zone Boiler Drain.
2. Connect a drain hose to the Indoor Boiler Drain.
3. Close the right isolation valve of the Zone Circulator.
4. Close the right isolation valve of the Indoor Circulator.
5. Open the Zone and Indoor Boiler Drains.
6. Open the fill hose valve.
7. Purge until no air can be heard leaving the drain hose.
8. Close the Indoor Ball Valve and open the right isolation valve of the Indoor Circulator.
9. Purge until no air can be heard leaving the drain hose.
10. Close the Zone Ball Valve and open the right isolation valve of the Zone Circulator.
11. Purge until no air can be heard leaving the drain hose.
12. Close the Indoor Ball Valve and open the right isolation valve of the Indoor Circulator.
13. Purge until no air can be heard leaving the drain hose.
14. Open the right isolation valve of the Indoor Circulator.
15. Open the Zone Ball Valve.
16. Close the Indoor Boiler Drain and then close the Zone Boiler Drain when the desired system pressure is obtained.

Repeat the above procedure as necessary to ensure that all of the air has been removed, then remove the purging equipment.

DOMESTIC HOT WATER CONNECTIONS

A typical piping diagram for a pre-heat tank configuration can be found in **drawing 000970PDG** at the end of this section. Be sure to note the position of the check valve and the direction of water flow. Other configurations are possible, and there may be multiple units tied together in larger buildings.

CAUTION: If two (2) shut-off valves are located on the domestic hot water lines as shown in the diagram, a pressure relief valve must be installed to prevent possible damage to the domestic hot water circulator pump should both valves be closed.



WARNING: USE ONLY COPPER LINES TO CONNECT THE DESUPERHEATER. TEMPERATURES COULD REACH 200F SHOULD THE DHW CUTOUT SWITCH FAIL, POTENTIALLY RUPTURING PEX PIPING.

Ensure the tank is filled with water and under pressure before activating the heat pump. Slightly loosen the boiler drain on the DHW Out pipe to allow air to escape from the system before the unit is started. This step will make certain that the domestic hot water circulator in the unit is flooded with water when it is started.



CAUTION: the domestic hot water pump is water lubricated; damage will occur to the pump if it is run dry for even a short period of time.

Connect the brown wire with the **blue insulated terminal** to L1 of the compressor contactor (fuse terminal for 575-3-60 units). **Ensure the power is off when connecting the wire.**

The DHW loop may have to be purged of air several times before good circulation is obtained. A temperature difference between the DHW In and DHW Out can be felt by hand when the circulator pump is operating properly.

For the pre-heat tank setup, the final tank should be set to **140°F(60°C)**, unless local code requires a higher setting. The pre-heat tank does not require electric elements. This setup takes full advantage of the desuperheater as it is the sole heat provider to the pre-heat tank. The desuperheater remains active during the compressor runtime until the pre-heat tank has been completely heated by the desuperheater alone. This setup is more energy efficient than a single tank setup.

DIAGRAM B - Circulator and Major Component Locations

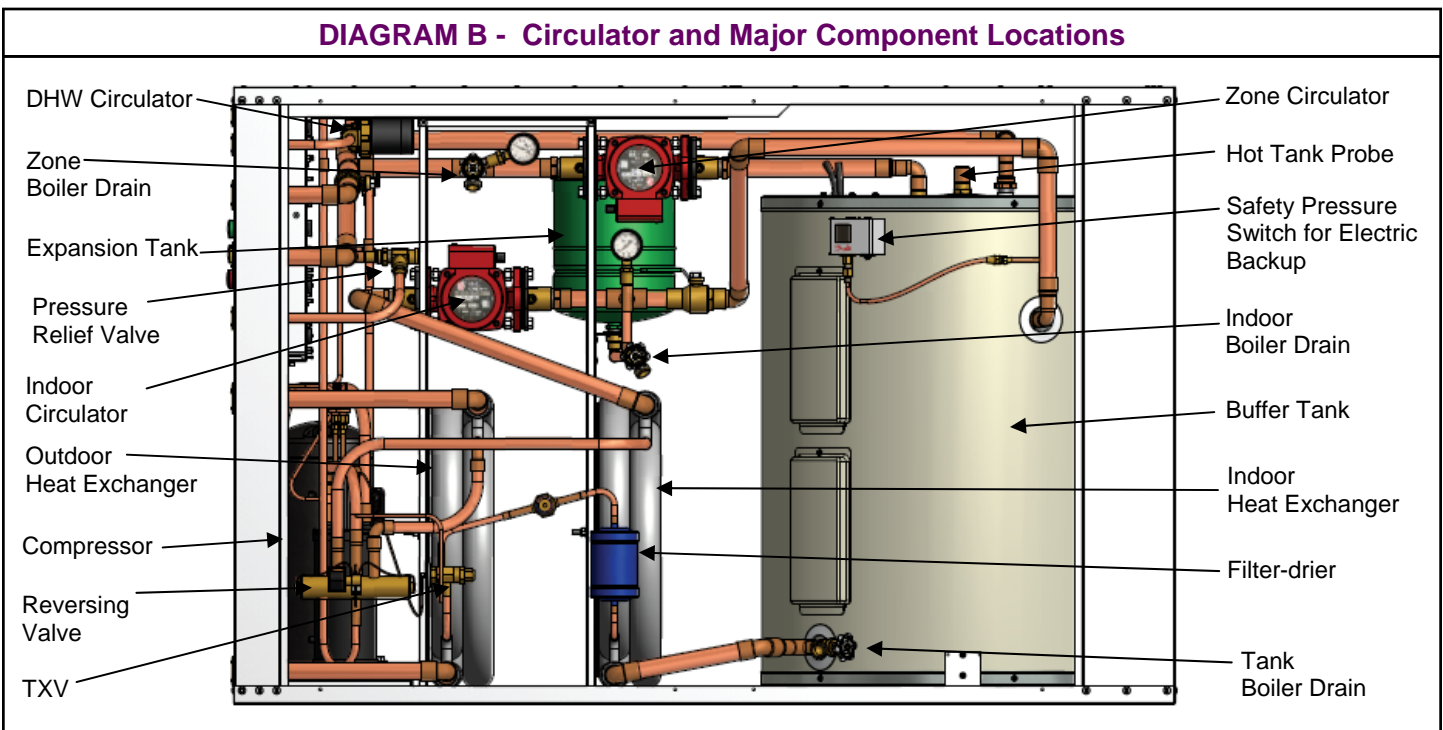

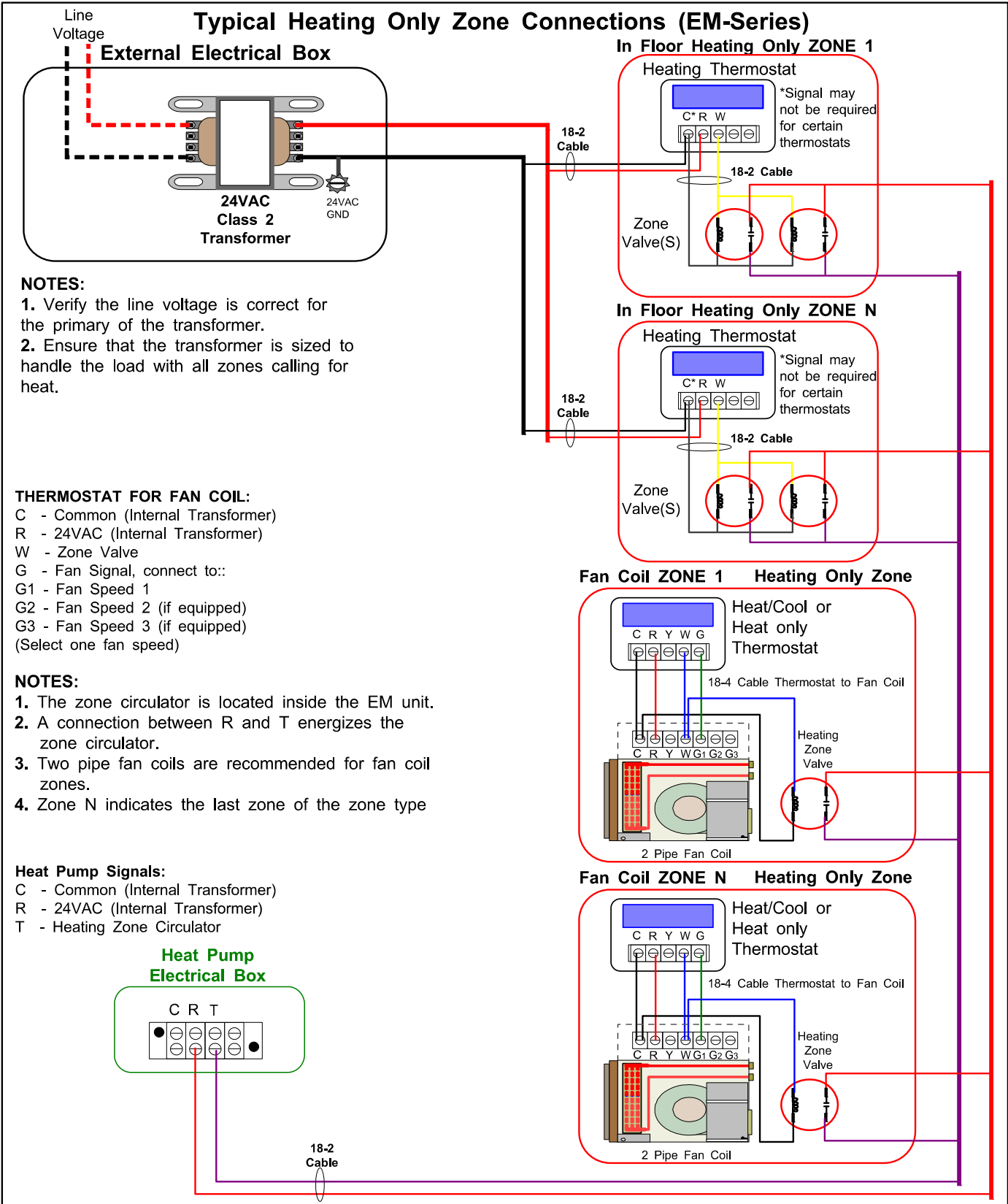

					Drawn By Chris Geddes	Date 07 SEP 07	MARITIME GEOTHERMAL LTD. 170 Plantation Rd. Petitcodiac, NB E4Z 6H4			
					Checked By Chris Geddes	Date 07 SEP 07				
					Approved By Chris Geddes	(ENG) Date 07 SEP 07	Drawing Name Typical Heating Only Zone Wiring Diagram (EM-Series)			
					Approved By (MFG)	Date				
01	Initial Release	C. GEDDES	C. GEDDES	07 SEP 07	Approved By	Date	Size A	Drawing Number 000531CDG	REV 01	SHEET 1 of 1
REV	ECO #	IMPL BY	APVD BY	DATE						

Typical Heating & Cooling Zone Connections (EM-Series)

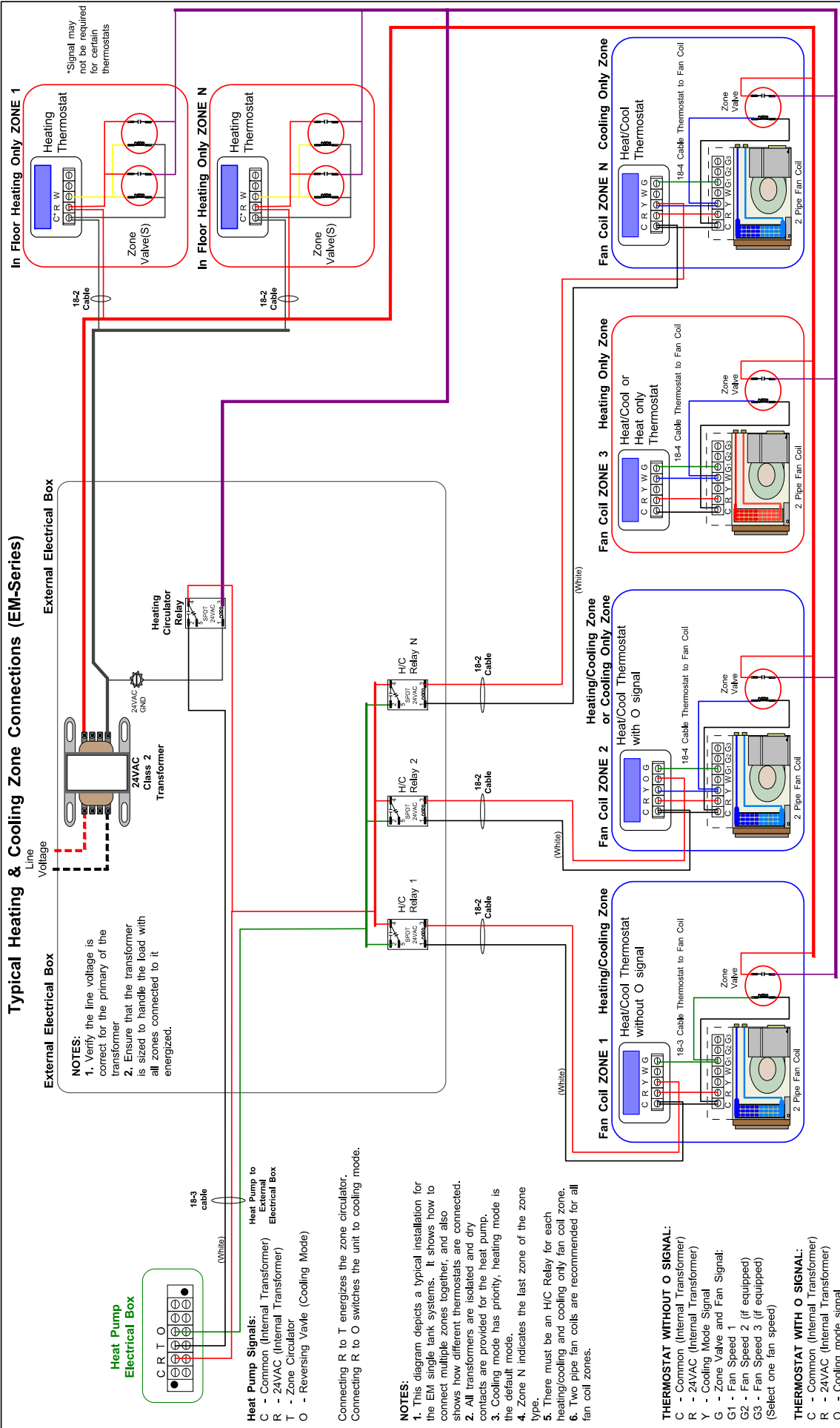

External Electrical Box

- NOTES:**
1. Verify the line voltage is correct for the primary of the transformer
 2. Ensure that the transformer is sized to handle the load with all zones connected to it energized.

Heat Pump Electrical Box

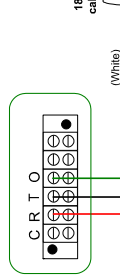

Heat Pump Signals:

- C - Common (Internal Transformer)
- R - 24VAC (Internal Transformer)
- T - Zone Circulator
- O - Reversing Valve (Cooling Mode)

Connecting R to T energizes the zone circulator.
Connecting R to O switches the unit to cooling mode.

NOTES:

1. This diagram depicts a typical installation for the EM single tank systems. It shows how to connect multiple zones together, and also shows how different thermostats are connected.
2. All transformers are isolated and dry contacts are provided for the heat pump.
3. Cooling mode has priority, heating mode is the default mode.
4. Zone N indicates the last zone of the zone type.
5. There must be an H/C Relay for each heating/cooling and cooling only fan coil zone.
6. Two pipe fan coils are recommended for all fan coil zones.

THERMOSTAT WITHOUT O SIGNAL:

- C - Common (Internal Transformer)
- R - 24VAC (Internal Transformer)
- Y - Cooling Mode Signal
- G - Zone Valve and Fan Signal:
- G1 - Fan Speed 1
- G2 - Fan Speed 2 (if equipped)
- G3 - Fan Speed 3 (if equipped)
- (Select one fan speed)

THERMOSTAT WITH O SIGNAL:

- C - Common (Internal Transformer)
- R - 24VAC (Internal Transformer)
- O - Cooling mode signal
- Y - Zone Valve Signal
- G - Fan Signal, connect to:
- G1 - Fan Speed 1
- G2 - Fan Speed 2 (if equipped)
- G3 - Fan Speed 3 (if equipped)
- (Select one fan speed)

Drawn By	Chris Geddes	Date	11 DEC 07
Checked By	Chris Geddes	Drawn Date	11 DEC 07
Approved By	Chris Geddes	Engineering Date	11 DEC 07
Approved By	Chris Geddes	(MFG) Date	
Initial Release	C. GEDDES	DATE	11 DEC 07
APVD BY	C. GEDDES	DATE	
ECO #	IMPL BY	DATE	
REV	ECO #	APVD BY	DATE
01			
Size	B	Drawing Number	000583CDG
REV			
01			
SHEET			
1			
1			
OF			
1			

MARTIME GEOTHERMAL LTD.
 Typical Heating & Cooling Zone Wiring (EM-Series)
 170 Plantation Rd.
 Pelletouche, NB
 E2Z 6K4

Single Unit Connection to Domestic Hot Water Pre-Heat Tank (Brass FPT)

Top Port Configuration

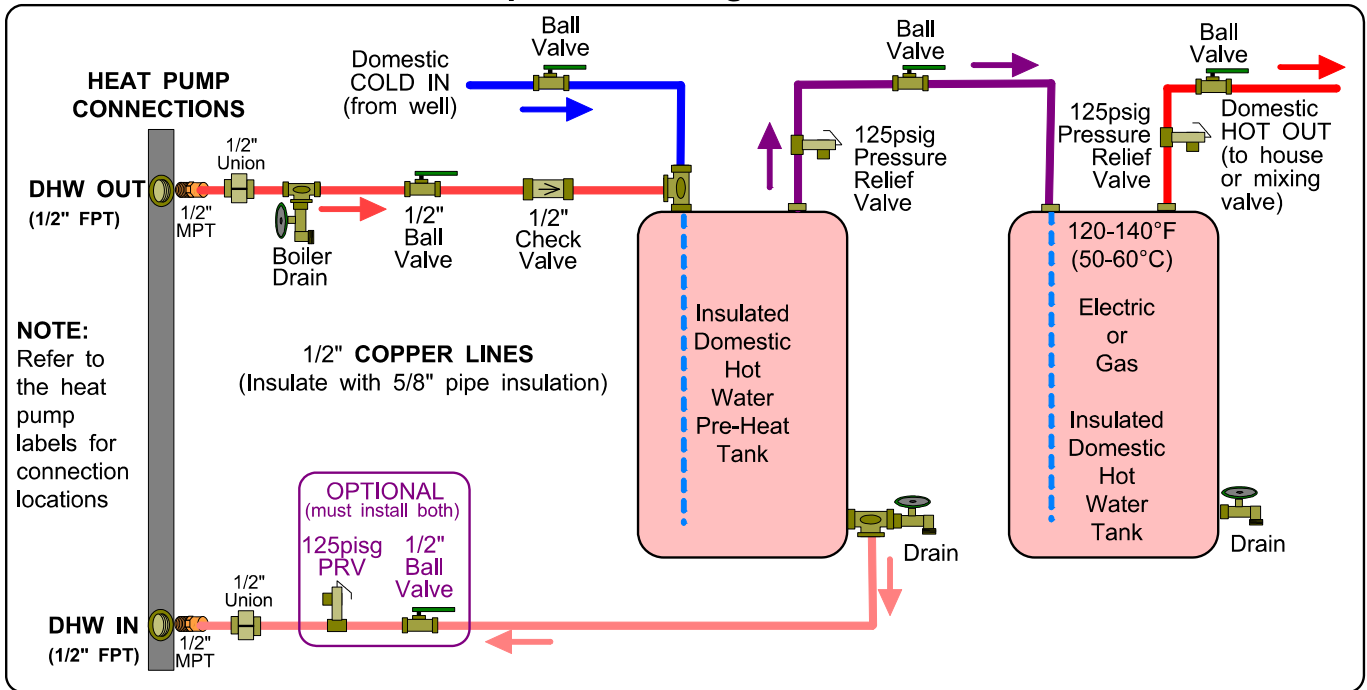

Side Port Configuration

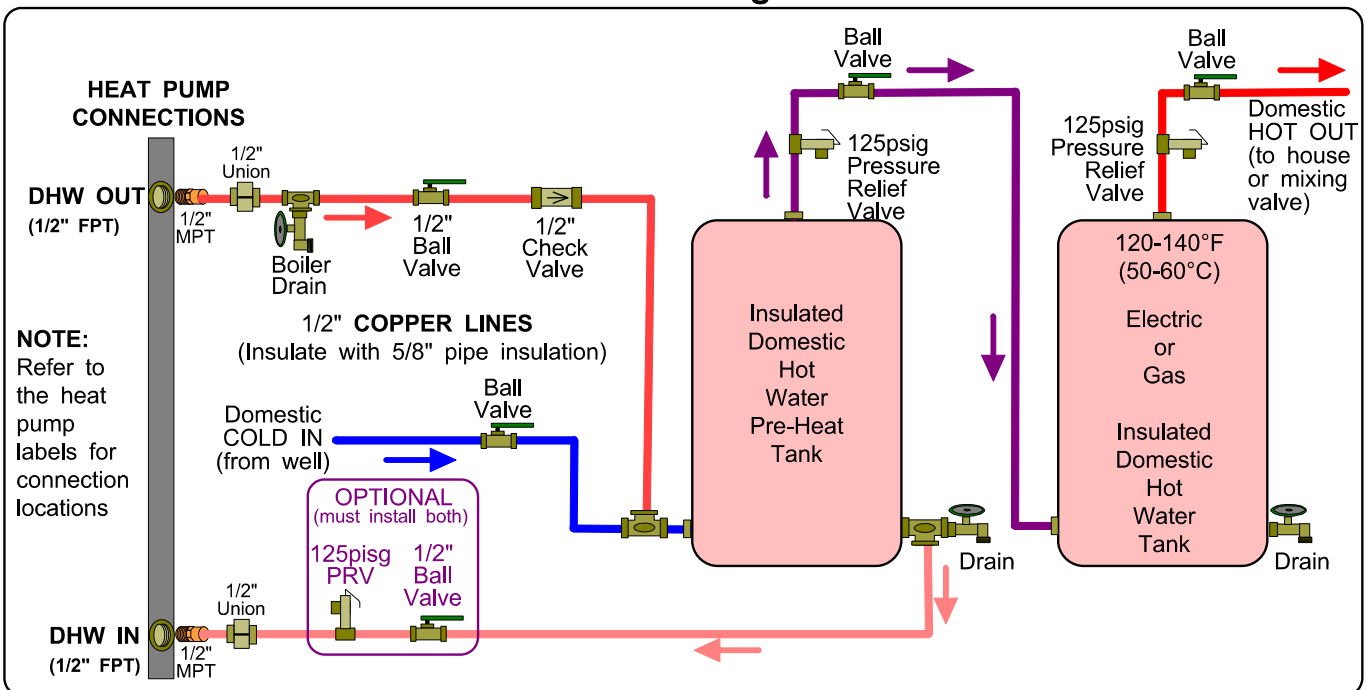

					Drawn By Chris Geddes	Date 10 MAR 09	MARITIME GEOTHERMAL LTD.	170 Plantation Rd. Petitcodiac, NB E4Z 6H4
					Checked By Chris Geddes	Date 10 MAR 09		
					Approved By Chris Geddes (ENG)	Date 10 MAR 09	Drawing Name Single Unit Connection	
					Approved By Chris Geddes (MFG)	Date	to DHW Pre-Heat Tank (Brass FPT)	
01	Initial Release	C. GEDDES	C. GEDDES	10 MAR 09	Approved By	Date	Size A	Drawing Number 000970PDG
REV	ECO #	IMPL BY	APVD BY	DATE				REV 01
								SHEET 1 of 1

Sizing and Hydronic Information

HEAT PUMP SIZING

TABLE 5 depicts a rough guideline as to the size of home each heat pump size can handle for **ground loop** installations.

TABLE 5 - Heat Pump Size vs. Heated Area for a Ground Loop System			
Model	Size (tons)	Sq.ft.	Sq.m.
45	3	1,400	130
55	4	2,000	185
65	5	2,600	240
75	6	3,100	290
80	6	3,500	325

TABLE 6 depicts a rough guideline as to the size of home each heat pump size can handle for **ground water** installations.

TABLE 6 - Heat Pump Size vs. Heated Area for a Ground Water System			
Model	Size (tons)	Sq.ft.	Sq.m.
45	3	1,800	165
55	4	2,500	230
65	5	3,200	295
75	6	3,800	355
80	6	4,200	390

THE TABLES ABOVE ARE FOR INFORMATION ONLY, THEY SHOULD NOT BE USED TO SELECT A UNIT SIZE.

They simply show on average what size unit is required for a typical two-level home (main level and below grade basement) with R-20 walls, R-40 ceiling and average size and number of windows. The Heated Area is the area of the main level, The tables account for a basement the same size as the heated area.

MARITIME GEOTHERMAL LTD. HIGHLY RECOMMENDS THAT A PROPER HEAT LOSS/GAN ANALYSIS BE PERFORMED BY A PROFESSIONAL INSTALLER WITH CSA APPROVED SOFTWARE BEFORE SELECTING THE SIZE OF UNIT REQUIRED FOR THE APPLICATION. For heating dominant areas, we recommend sizing the unit to 100% of the heating design load for maximum long term efficiency with minimal supplementary heat. The unit should be installed as per CSA 448.2-02. For ground loop applications, the ground exchanger should be designed using suitable software with a multi-year analysis.

There are many factors to consider when sizing the heat pump. Some of these factors include the number of levels, the size of the windows, the orientation of the home, attached garage, bonus rooms, walk-in basement, coldest outdoor temperature, etc. The heat loss program will take all of these factors into consideration in its calculations. An undersized installation will require not be as efficient and will require expensive auxiliary heat to maintain a comfortable temperature in the home, and the cost savings of having a geothermal heat pump are greatly reduced.

Once the total heat loss has been calculated, the unit can be sized using the performance tables (from the specifications document) in conjunction with the minimum expected entering liquid temperature of the ground loop (well water temperature for ground water system). The heat pump output must be able to match the total heat loss at the selected entering water temperature in order to provide a comfortable environment with minimal auxiliary heat.

HYDRONIC SYSTEMS - GENERAL

Hydronic systems typically provide heat through two different types of media:

- radiant in-floor heating
- forced air heating via fan coil units

One of the benefits of hydronic systems is the flexibility in setting up the heating system. Whereas a typical forced air system has one central thermostat controlling the entire heating system, the home may be sectioned into several areas called zones with a hydronic system. Each zone has its own thermostat, allowing simple separate temperature control of the individual areas in the home.

There are other uses for hydronic systems, the two most common being on-demand domestic hot water and pool/spa heating. **Drawing 000530PDG** shows the most common types of zones. A typical system consists of the heat pump, the buffer tank and the zones. For the EMW-Series, the buffer tank is part of the heat pump unit. The heat pump's sole purpose is to maintain the buffer tank set point. Its operation is independent of the zone operation.

Fan coils can be used to provide heating and/or cooling for areas that do not have radiant in-floor heating. They provide a means of air heating/cooling with minimal or no ductwork. Note that the buffer tank temperature should be set for **115°F (46°C)** if there are fan coils in the system.

Two port fan coils are recommended for connection to the system as a single tank is used for heating and cooling.

It is recommended that all piping be insulated with 3/8" thick closed cell pipe insulation. This is a **MUST** for any piping that is used for cooling to prevent dripping onto floors and walls. Care should be taken when wiring the system to ensure that radiant in-floor heating zones are disabled whenever the heat pump is switched to cooling mode.

Typical Zone Types for Hydronic Applications

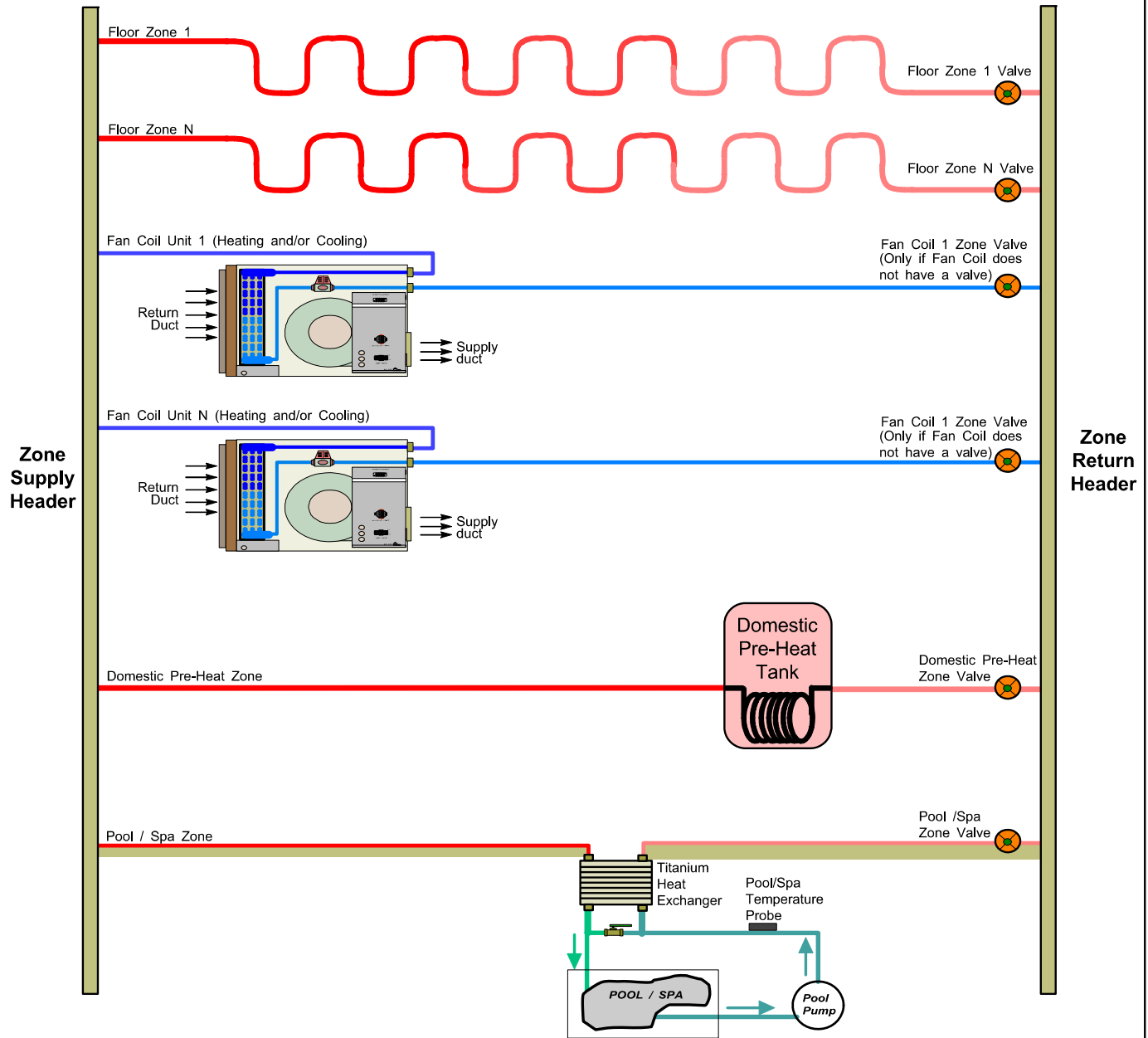

NOTES:

1. Floor zones are heating only. Cooling a floor zone will cause condensation in the floor. Floor zone valves should be wired through a relay that is controlled by the cooling signal (O) that breaks the signal when in cooling mode to ensure that they cannot accidentally be energized.
2. There may be multiple floor zones.
3. There may be multiple fan coil units, (heating and /or cooling). A zone valve is not required if the unit has a internal valve.
4. Domestic Pre-Heat Tank is for on-demand applications. The tank must have a heat exchanger in it or an external one must be used to separate the zone loop from the potable water supply.
5. Ensure the floor circulator is adequately sized to accommodate the type and number of zones connected to the system.
6. The pool aquastat will operate the Pool/Spa Zone Valve.

					Drawn By Chris Geddes Date 06 SEP 07		170 Plantation Rd. Petitcodiac, NB E4Z 6H4		
					Checked By Chris Geddes Date 06 SEP 07		Drawing Name Typical Zone Types for Hydronic Applications		
					Approved By (ENG) Chris Geddes Date 06 SEP 07	Size A	Drawing Number 000530PDG	REV 01	SHEET 1 of 1
01	Initial Release	C. GEDDES	C. GEDDES	06 SEP 07	Approved By (MFG) Approved By Date				
REV	ECO #	IMPL BY	APVD BY	DATE					

Ground Water System Information

GENERAL REQUIREMENTS

1. The temperature of the well water should be a minimum of **39°F (4°C)**, and should normally be **45+°F (7°C)**
2. The well system must be able to supply the required water flow as listed under the Total Flow column in **TABLE 7**.

TABLE 7 - Required Flow and Air Tank Sizing

Heat Pump Model Size	Heat Pump Flow* IGPM (USGPM)	Home Flow IGPM (USGPM)	Total Flow IGPM (USGPM)	Minimum Air Bladder Tank** IGal (USgal)
45	8 (9.6)	3 (3.6)	11(13.2)	22(26)
55	10 (12.0)	3 (3.6)	13(15.6)	26(31)
65	12 (14.4)	3 (3.6)	15(18.0)	30(36)
75	14 (16.8)	3 (3.6)	17(20.4)	34(41)
80	14 (16.8)	3 (3.6)	17(20.4)	34(41)

* These are minimum water requirements based on an entering water temperature of 46° F.

**Based on two-minute well pump run time. Use next size larger tank if there is not a match for the value indicated.

PLUMBING THE HEAT PUMP

Plumbing lines, both supply and discharge, must be of adequate size to handle the water flow necessary for the heat pump. A 1" copper or plastic line should be run to the Outdoor IN (Supply IN) pipe of the heat pump. Similarly, a 1" line should be run from the Outdoor OUT (Supply Out) pipe to the method of disposal. P/T plugs should be installed at each port. See **Diagram C** in the Ground Loop section for a description of P/T plugs. The water valve should be installed in the discharge line. **Refer to drawing 000907CDG at the end of this section** for the recommended setup. Placing the water valve in the discharge line ensures that the heat exchanger inside the heat pump remains full of water when the unit is not running. Unions or some other form of disconnect should be used so that the coaxial heat exchanger may be accessed should it required cleaning.

The heat pump has an electrical connector for the water valve just inside the case. After the water valve is installed, run the valve harness into the case through the hole provided. Remove the jumper plug from the Valve Connector and connect the harness in its place.

Ideally there will be water flow available in excess of the requirement of the heat pump. In such a situation the proper pump can be selected to maintain a pressure of 30 to 40 psig. on the lines when the heat pump is operating. However in some cases a well can supply a heat pump only if the minimum requirement for water is used.

Water flow to the heat pump can be controlled very accurately by the installation of a reverse action refrigeration pressure valve in the discharge line of the unit.

Another more common method of regulating the flow is by the use of a **DOLE** Valve. This valve will automatically control the amount of water flowing through it by varying the diameter of a flexible rubber orifice through which the water passes. This minimizes the water usage of the unit and also prevents a reversing unit from running excessively low discharge pressure when in cooling mode. Dole valves can be noisy, it is recommended that they be installed outside if possible.

Optionally a water flow meter can be installed in the discharge line so that the exact amount of water flowing can be determined at a glance. It should be placed between the Outdoor OUT (Supply OUT) pipe of the heat pump and the water valve.

With proper flow, there should be **5-7°F (3-4°C)** delta T between the IN and OUT water temperatures of the heat pump when operating in the heating mode.

All water line valves on both the supply and discharge lines should be either BALL or GATE valves. GLOBE valves have a higher pressure drop, meaning more pumping power to maintain the required flow to the heat pump.

PIPE INSULATION

All ground water piping to and from the Outdoor Loop ports on the heat pump should be insulated with 3/8" closed cell pipe insulation, to prevent condensation and dripping onto floors or walls.

WATER DISCHARGE METHODS

Water disposal methods vary from area to area. However, some consideration should be made to prevent the cooled discharge water from immediately coming in contact with the supply source. Attempting to return the water to the source well will eventually cool the water so much that the heat pump will shut off on its low pressure safety control.

Acceptable methods for disposing of the waste water are listed below. The waste water is clean, the heat pump has no other effect than reducing the temperature of the water. **Refer to drawing 000619INF** for typical disposal method diagrams.

- Second well (return well)
- Percolation (Drain, ditch, leaching field)
- Pond, river or stream.

ENSURE SELECTED METHOD CONFORMS TO LOCAL CODES.

A return well should be a minimum of **80 ft.** from the supply well for residential applications. The water returned to the well will not necessarily be pumped into the same aquifer, depending on underground conditions. The return must be able to supply at least the same quantity of water as the amount you wish to recharge into it. If the static level (level when not being pumped) of a well is high (10 to 20 ft. from the surface) it may be necessary to place a well cap on the well to keep the return water from flowing out the top of the well. This cap is commonly required since a certain amount of pressure is needed to force the return water back down the well if the static level is high.

Water discharged by percolation will generally soak into the ground within a distance of 50 to 100 ft. If suitable care is taken to ensure that the drain pipe runs downhill and the end of the pipe is protected by a bale of hay or spruce bows etc. the end of the pipe will not freeze as the pipe will empty out when the heat pump shuts off and the water valve closes.

When snow comes it will usually cover the entire process much like a small spring. It is recommended that the pipe be below the frost line when possible for maximum freeze protection.

When discharging into a river or stream, or above the surface of a pond, the same guidelines should be followed as described in the paragraph above for the percolation method.

When discharging the waste water below the surface of a pond, the discharge pipe should be placed below the frost line to prevent the pipe from freezing. As opposed to the percolation method, water will remain in the end of the pipe. It is recommended that the surface of the pond be lower than the installation location of the heat pump where practical. This reduces the back pressure generated by the weight of the water in the pond.

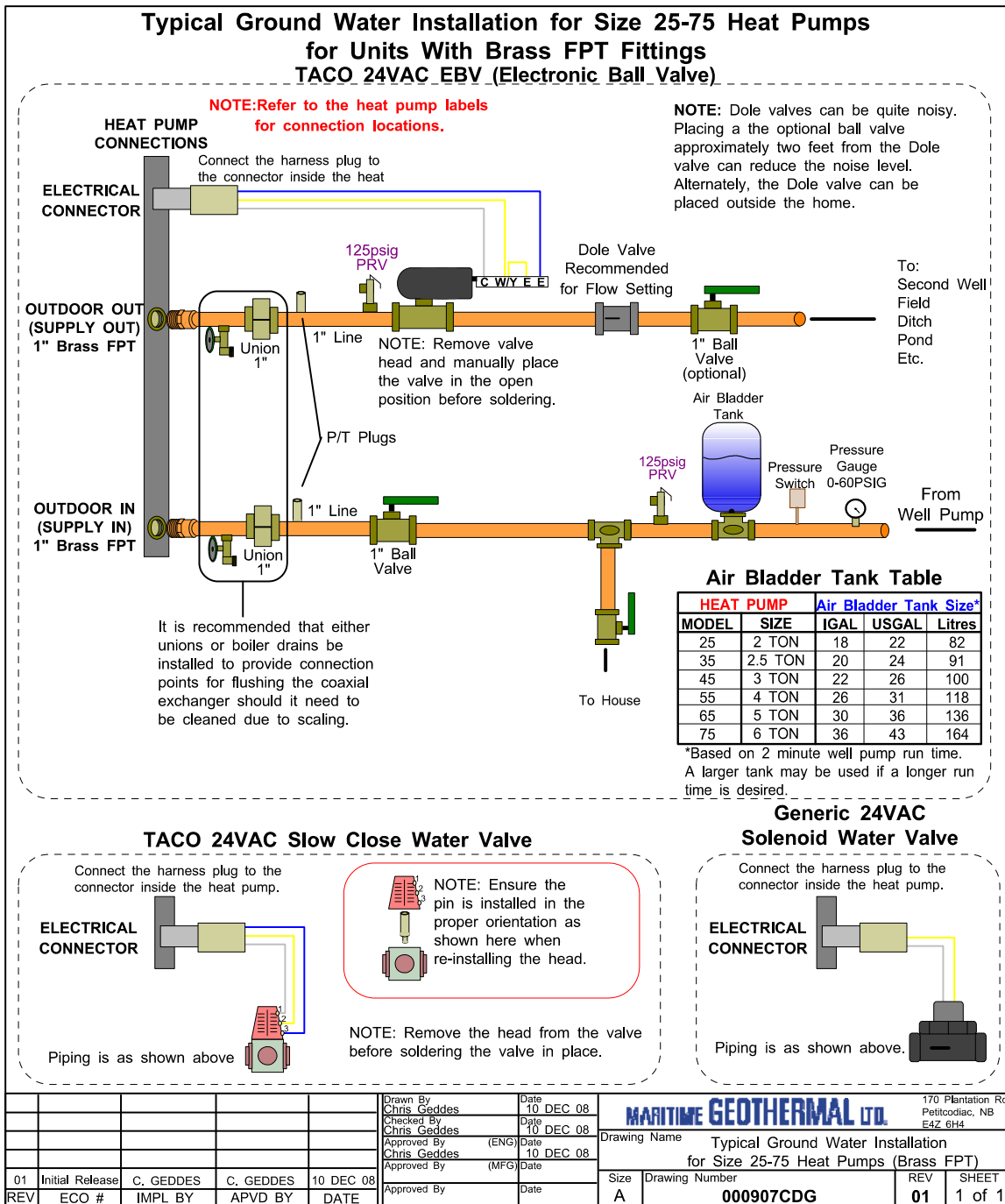

GROUND WATER DISPOSAL METHODS

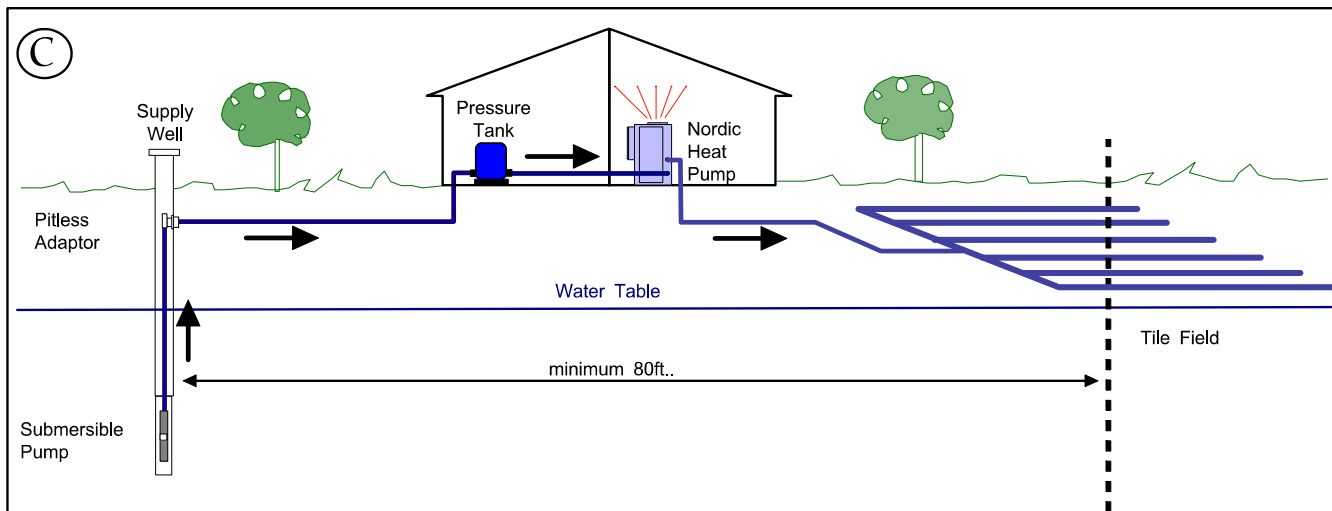
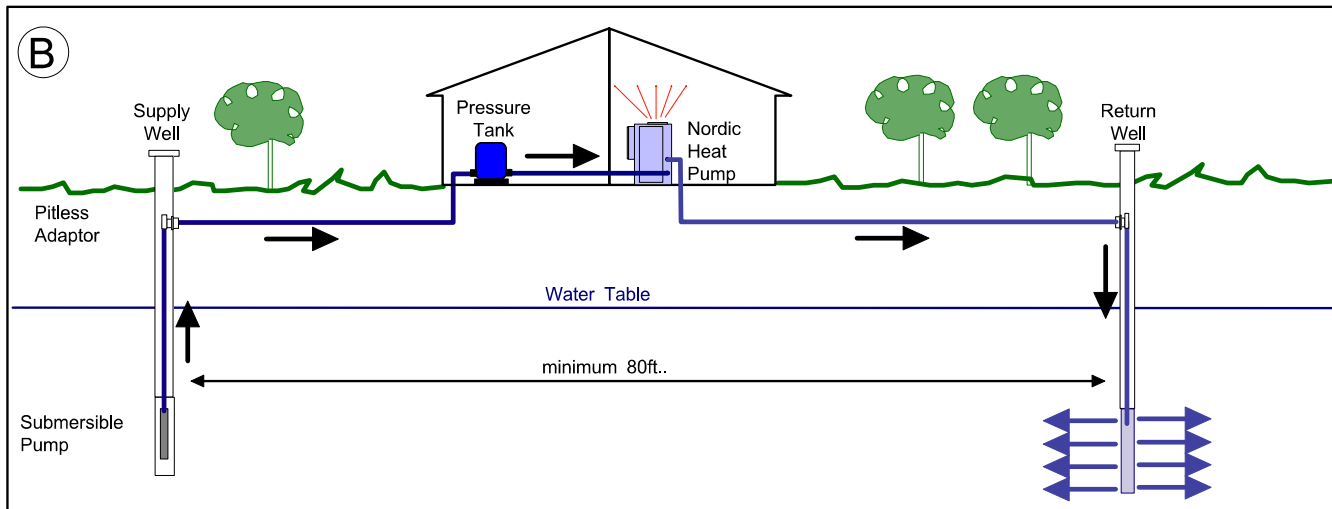
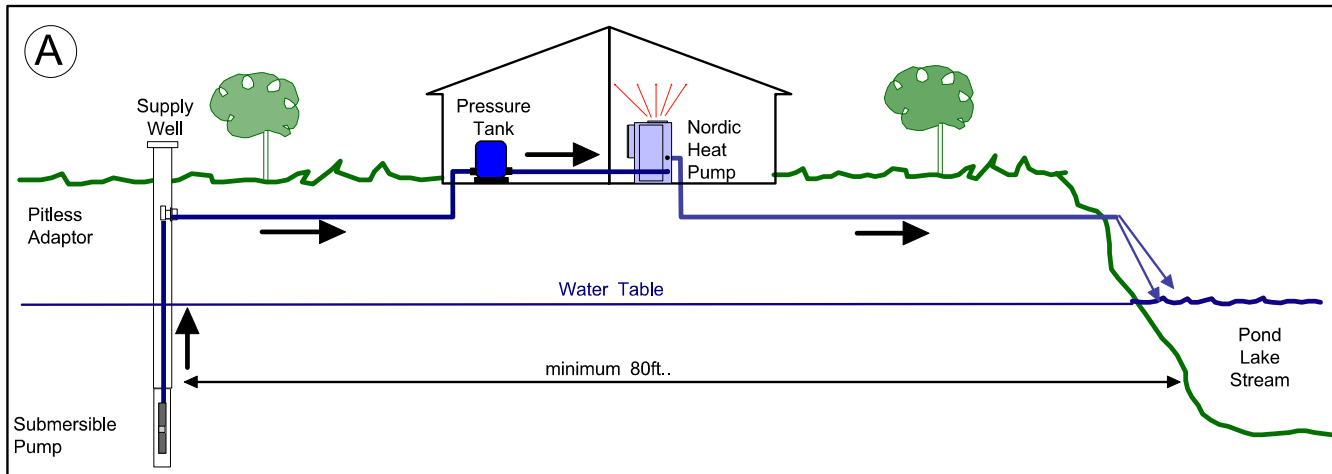

						Drawn By Chris Geddes	Date 04 FEB 08	MARITIME GEOTHERMAL LTD.	170 Plantation Rd. Petitcodiac, NB E4Z 6H4		
					Checked By Chris Geddes	Date 04 JAN 08	Drawing Name				
					Approved By (ENG) Chris Geddes	Date 04 FEB 08	Ground Water Disposal Methods		Size	Drawing Number	REV
01	Initial Release	C. GEDDES	C. GEDDES	04 FEB 08	Approved By (MFG)			A	000619INF	01	1 of 1
REV	ECO #	IMPL BY	APVD BY	DATE	Approved By		Date				

Ground Loop System Information

Once the ground loop has been pressure tested and the header pipes have been connected to the circulator pump module, the heat pump can be connected to the circulator pump module.

CIRCULATOR PUMP MODULE

Maritime Geothermal Ltd. has compact pump modules with built in three way valves to facilitate filling and purging the ground loop. Refer to drawing 000906CDG at the end of this section. Alternatively, Grundfos® Model UPS 26-99 or Taco® Model 0011 pumps or other brands with similar pumping capability may be used. The single pump module will typically handle systems up to 3 tons (model sizes 25, 35, and 45); the two pump module will typically handle 4 to 6 ton systems (model sizes 55, 65, 75, 80). This is based on a typical parallel system with one circuit per ton.

Maritime Geothermal recommends calculating the total pressure drop of the ground loop (including headers, indoor piping and heat pump exchanger drop) based on the antifreeze type and concentration at the desired minimum loop temperature. A pump module that can deliver the flow required for the unit at the calculated total pressure drop should be selected. Refer to the Model Specific Information section for unit flow requirements.

Loop pressure drops can be calculated using software such as those mentioned in the Horizontal Ground loops section, or can be calculated in a spreadsheet using the pipe manufacturer's pressure drop tables for pipe diameter and fittings.

The circulator pump module must be connected to the heat pump Outdoor Loop ports with a lineset suitable for the flow required with minimum pressure drop. 1" rubber or plastic lines should be used. The installation of P/T plugs (pressure / temperature, pronounced "Pete's plugs") is recommended on both the entering and leaving lines at the heat pump (see Diagram C).

DIAGRAM C - Typical P/T - "Pete's" Plug & Thermometer Stems

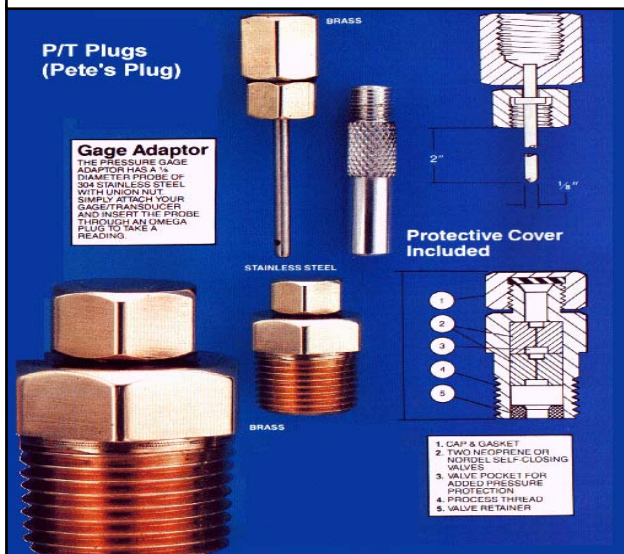

The P/T plug will allow the installer or homeowner to check water flow through the loop by measuring the pressure difference through the heat exchanger and comparing it to that listed in the **Model Specific Information section**, or the specifications document. Optional fittings with P/T ports are available for the circulator pump modules sold by Maritime Geothermal Ltd..

FLUSHING & PURGING THE GROUND LOOP

Once the groundloop has been installed and all connections are completed between the heat pump, circulator pump module and ground loop, the entire ground loop system should be **pressure tested with air to 100 PSIG** to make sure there are no leaks on any of the inside fittings. Soap all joints and observe that the pressure remains constant for 1 hour.

When satisfied that all connections are leak free, release the air pressure and connect a purge cart (see Diagram D) to the flushing access ports at the pump module (refer to drawing 000906CDG). A temporary flushing system can alternately be constructed using a 45 gal. barrel and a pump with sufficient volume and head capability to circulate fluid at a **velocity of at least 2 ft./min.** through all parts of the loop.

DIAGRAM D - Typical Purge Cart

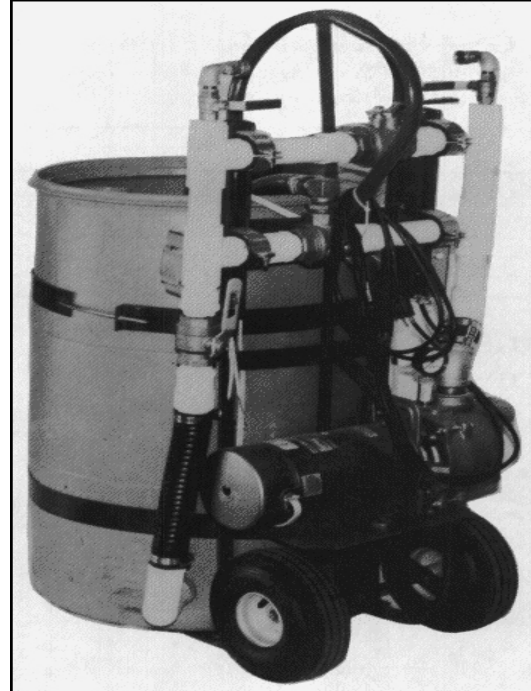

Adjust the circulator pump module valves to connect the purge cart to the ground loop. Begin pumping water through the ground loop, ensuring that the intake of the pump stays submerged at all times by continuously adding water. Water flowing back from the return line should be directed below the water level in the barrel or flush tank to prevent air being mixed with the outgoing water.

Once the lines have been filled and no more air bubbles are appearing in the line, adjust the circulator pump module valves to circulate water through the heat pump using the same technique as described above. When all air is removed reverse the flow of water through the lines by interchanging the flush cart lines and purge again. You will be able to visibly tell when all air is removed.

ADDING ANTIFREEZE SOLUTION

In most mid and northern areas of the US and in all of Canada it is necessary to condition the loop fluid by the addition of some type of antifreeze solution so that it will not freeze during operation in the winter months. This antifreeze is required because the loop fluid will normally reach a low entering temperature of **28°F to 32°F (-2°C to 0°C)** and refrigerant temperatures inside the heat pump's heat exchanger may be as low as **20°F (11°C)** cooler. See **TABLE 8** for details of freeze protection provided by different concentrations.

TABLE 8 - Antifreeze Percentages				
BY VOLUME				
Protection to:	10°F	15°F	20°F	25°F
Methanol	25%	21%	16%	10%
Propylene Glycol	38%	30%	22%	15%
BY WEIGHT				
Protection to:	10°F	15°F	20°F	25°F
Methanol	16.8%	13.6%	10%	6.3%
Propylene Glycol	30%	23.5%	18.3%	12.9%

NOTE: Add enough antifreeze to allow for a temperature 20°F lower than the expected lowest loop fluid temperature entering the heat pump.

Although many different antifreeze solutions have been employed in geothermal systems, the alcohols such as methanol or ethanol have the most desirable characteristics for groundloop applications. The overall heat transfer characteristics of these fluids remain high although care must be taken when handling pure alcohols since they are extremely flammable. Once mixed in a typical 25% by volume ratio with water the solution is not flammable. In situations where alcohols are not allowed as a loop fluid due to local regulations then propylene glycol is a non-toxic alternative which can be substituted. Propylene glycol should only be used in cases where alcohols are not permitted since the heat transfer characteristics are less desirable and it becomes more viscous at low temperatures, increasing pumping power.

The volume of fluid that your loop system holds can be closely estimated by totaling the number of ft. of each size pipe in the system and referencing **TABLE 9** for approximate volume per 100 ft.

When the volume of the loop has been calculated and the appropriate amount of antifreeze is ready for addition by referencing **TABLE 8**, drain the equivalent amount of water from the flush cart or mixing barrel and replace it with the antifreeze.

When using alcohols, be sure to inject below the water line to reduce initial volatility of the pure antifreeze. If the loop is large it may be necessary to refill the tank with antifreeze several times to get all the antifreeze into the loop. Pump the loop for 5 to 10 minutes longer to ensure the remaining fluid has been well mixed.

TABLE 9 - Volume of fluid per 100 ft. of pipe				
		Volume /100ft.		
Type of Pipe	Diameter	Igal	USgal	L
Copper	1"	3.4	4.1	15.5
	1-1/4"	5.3	6.4	24.2
	1-1/2"	7.7	9.2	34.8
Rubber Hose	1"	3.2	3.9	14.8
Polyethylene	3/4" IPS SDR11	2.3	2.8	10.6
	1" IPS SDR11	3.7	4.5	17.0
	1-1/4" IPS SDR11	6.7	8.0	30.3
	1-1/2" IPS SDR11	9.1	10.9	41.3
	2" IPS SDR11	15.0	18.0	68.1
Other Item Volumes				
Heat Exchanger	Average	1.2	1.5	5.7
Purge Cart Tank	See cart manual	TBD		

INITIAL PRESSURIZATION

At this point open all valves in the flow circuit and slowly close off the supply and return flush cart valves in a manner that leaves about **20-30 psig.** on the system. If an air bladder expansion tank is used it should be charged to the above pressure before actual water pressure is put on the system. Systems without an expansion tank will experience greater fluctuations in pressure between the heating and cooling seasons, causing pressure gauges to have different values as the loop temperature changes. This fluctuation is normal since expansion and contraction of the loop fluid must be handled by the elasticity of the plastic loop.

- Pressurize the loop to a static pressure of **45 psig.** when installing a system in the fall going into the heating season.
- Pressurize the loop to a static pressure of **25 psig.** when installing a system in the spring or summer going into the cooling season.

After operating the heat pump for a period of time, any residual air in the system should be bled off and the static pressure should be verified and adjusted if necessary. Add additional water / antifreeze mix with the purge cart to bring the pressure back to the original setting if required.

PIPE INSULATION

All ground loop piping inside the structure (between the structure entry point and the heat pump) should be insulated with 3/8" thick closed cell pipe insulation to prevent condensation and dripping onto floors or walls.

Geo-Flo Circulator Pump Module Installation (Units with Brass FPT Fittings)

2911 - 1" to 1-1/4" PE Socket

1" Fill & Purge access ports
2914 Camlocks can be used for quick connections. Fittings can be removed and reused on other jobs when purging is complete

Connect wiring to appropriate voltage terminals marked **OUTDOOR CIRCULATORS** in the heat pump electrical box

NOTE:
 Refer to the heat pump labels for connection locations

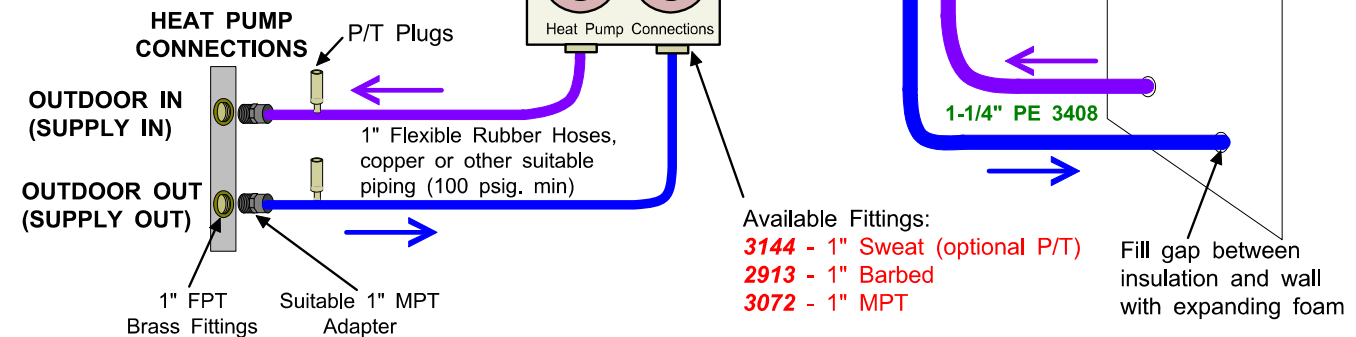

NOTES:

- Circulator Pump Module should be mounted vertically to minimize the possibility of air locking the circulators.
- All lines inside the structure and through the wall should be insulated with 3/8" to 1/2" thick closed cell pipe insulation.
- Holes through the foundation / structure should be filled with expanding foam from both sides to prevent leakage.
- Proper drainage material should be used on the outside of the wall to prevent water buildup.
- Pump module fittings are available from Maritime Geothermal Ltd., Geo-Flo Part Numbers are indicated above (italics).
- A pressure gauge is recommended if P/T plugs are not installed.
- The air bladder tank should be pressurized to the desired static pressure of the ground loop before installation.
- For most applications, a 1 pump module will accommodate NORDIC models sizes 25, 35, and 45, and a 2 pump module will accommodate sizes 55, 65 and 75. The total loop pressure drop including the headers, inside piping and heat exchanger drop should be calculated based on the antifreeze mixture and lowest desired entering water temperature. The pump module selected must provide the required flow at this calculated pressure drop value.

CIRCULATOR PUMP MODULE 3-WAY VALVE POSITIONS (LEFT SIDE VIEW)

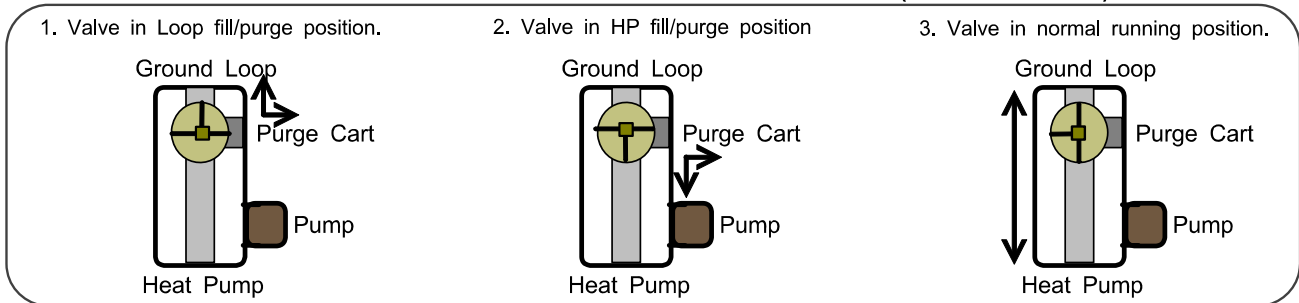

						Drawn By Chris Geddes	Date 09 DEC 08	MARITIME GEOTHERMAL LTD.		170 Plantation Rd. Petitcodiac, NB E4Z 6H4	
						Checked By Chris Geddes	Date 09 DEC 08				
						Approved By Chris Geddes	(ENG) Date 09 DEC 08	Drawing Name Geo-Flo Circulator Pump Module Installation (Brass FPT)			
						Approved By Chris Geddes	(MFG) Date	Size A	Drawing Number 000906PDG	REV 01	SHEET 1 of 1
01	Initial Release	C. GEDDES	C. GEDDES	09 DEC 08		Approved By	Date				
REV	ECO #	IMPL BY	APVD BY	DATE							

Startup Procedure

The following steps describe how to perform the startup procedure of the geothermal heat pump.

The EMW-Series Two-Stage R410a Startup Record located in this manual is used in conjunction with this startup procedure to provide a detailed record of the installation. A completed copy should be left on site, a copy kept on file by the installer and a copy should be sent to Maritime Geothermal Ltd.

Check the boxes or fill in the data as each step is completed. For data boxes, circle the appropriate units. Fill in the top section of all three copies, or one copy if photocopies can be made after the startup has been completed.

PRE-START INSPECTION

Indoor and Zone Loops (Hydronic):

1. Verify that all shutoff valves inside the unit are fully open.
2. Verify that the entire system has been flooded and all the air has been purged as much as possible. Further purging may be required after the system has been operating for a while.
3. Verify that the loop contains the proper mix of antifreeze (if used) for the intended application. If applicable, record the type of antifreeze and the mixture value on the startup sheet, circle % Vol. or % Weight.
4. Record the static loop pressure on the startup sheet. **The value must be above 12PSIG.** The electric heat will not function if the pressure is below this value.

Outdoor Loop (Ground Loop):

1. Verify that all shutoff valves are fully open and there are no restrictions in the piping from the heat pump to the ground loop, and that full flow is available to the heat pump.
2. Verify that the entire system has been flooded and all the air has been purged as much as possible. Further purging may be required after the system has been operating for a while.
3. Verify that the loop contains the proper mix of antifreeze for the intended application. Record the type of antifreeze and the mixture value on the startup sheet; circle % Vol. or % Weight.
4. Record the static loop pressure on the startup sheet.

Outdoor Loop (Ground Water):

1. Verify there are no leaks in the connections to the unit. Verify the water valve is installed and properly oriented in the return line.
2. Verify that there is flow control in the return line.

Domestic Hot Water (if equipped):

1. Verify that all shutoff valves are fully open and there are no restrictions in the piping from the heat pump to the domestic hot water tank.
2. Verify that the entire system has been flooded and all the air has been purged as much as possible. Further purging may be required after the system has been operating for a while.
3. Verify that the brown wire with the insulated terminal is disconnected in the electrical box. Refer to the schematic diagram for more information.

Electrical:

1. **Ensure the power to the unit is off.**
2. Verify all high voltage connections. Ensure that there are no stray wire strands, all connections are tight and the ground wire is connected tightly to the ground connector for the heat pump.
3. Record the fuse / circuit breaker size and wire gauge for the heat pump.
4. Verify that the control connections to the are properly connected and all control signals are off.
5. Turn both breakers off in the unit electrical box , so that the unit will not start when the power is turned on.
6. Verify that the circulator pumps are connected to the proper voltage terminals in the heat pump. Record the voltages of the circulator pumps.
7. Ensure all access panels except the one that provides access to the electrical box are in place.

UNIT STARTUP

The unit is now ready to be started. The steps below outline the procedure for starting the unit and verifying proper operation of the unit. **It is recommended that safety glasses be worn during the following procedures.**

Preparation:

1. Remove the caps from the service ports and connect a refrigeration manifold set to the unit.
2. Turn the power on to the heat pump and set all controls (including all zone thermostats) to OFF.
3. Measure the following voltages on the power block and record them on the startup sheet: L1-L2, L2-L3, L1-L3.
4. Verify that the green light on the side of the cabinet is on.

Heating Mode:

1. Turn the compressor breaker on. The compressor will start (allow 30-60 seconds for the water valve to open for ground water systems) as well as the circulator pumps.
2. Check the refrigeration gauges. The suction and discharge pressures will depend on the loop temperatures, but they should be about **90-110PSIG** and **250-320PSIG** respectively for a typical start-up.
3. Monitoring the refrigeration gauges while the unit runs. Record the following after 10 minutes of runtime:
 1. Suction pressure
 2. Discharge pressure
 3. Outdoor Loop In (Supply In) temperature
 4. Outdoor Loop Out (Supply Out) temperature
 5. Outdoor Delta T (should be between **5-8°F, 3-4°C**)
 6. Outdoor flow (if available)
 7. Compressor L1(C) current (black wire, place meter between electrical box and compressor)
4. Let the unit run through a cycle. Record the setpoint and the discharge pressure when the unit shuts off.
5. For units with a desuperheater, turn the power off to the unit. Connect the brown wire with the blue insulated terminal to the compressor contactor as shown in the electrical box diagram. Turn the power to the unit on.
6. Open a zone (or zones) and let the tank cool down until Stage 2. is activated. Close the zone(s) again.
7. Verify the DHW IN and DHW OUT temperatures (if applicable) by hand (**caution: pipes get hot**). If the DHW OUT line does not become hotter than the DHW IN line the circulator is air locked. Bleed the air from the system and check the temperature differential again to ensure there is flow from the circulator.
8. Turn the electric heat timer knob counter-clockwise as far as it will go. Turn on the electric heat breaker inside the unit. The yellow light on the side of the unit should turn on. Measure the L1 current draw with a clamp meter and record the value. It should be between 45 and 52A.
9. Set the electric heat timer to the desired setpoint (0-2hours). 1 hour is the minimum recommended value.

Cooling Mode (Reversing units only):

1. Turn the compressor breaker inside the unit off. Set a zone thermostat to cooling mode to switch the unit to cooling mode.
2. Turn the compressor breaker on again.
3. Monitoring the refrigeration gauges while the unit runs. Record the following after 10 minutes of runtime:
 1. Suction pressure
 2. Discharge pressure
 3. Outdoor Loop In (Supply In) temperature
 4. Outdoor Loop Out (Supply Out) temperature
 5. Outdoor Delta T
4. Allow the unit to run through a cycle. Record the aquastat setpoint and the suction pressure when the unit shuts off.

Final Inspection:

1. Turn the compressor breaker off. Set the aquastat(s) to the final settings and record the values.
2. Turn the power off to the unit and remove all test equipment. Turn the compressor breaker back on.
3. Install the electrical box cover and the access panel on the heat pump. Install the service port caps securely to prevent refrigerant loss.
4. Do a final check for leaks in the ground water / ground loop system and ensure the area is clean.
5. Turn the power to the unit on. Set all zone thermostats to the desired values.

Startup Record:

1. The startup personnel shall sign and date the Startup Record and have the startup witness or appropriate site personnel sign as well. The startup personnel shall leave the Startup Record with the homeowner, retain a copy for filing and send a copy to Maritime Geothermal Ltd. for warranty registration.

Startup Record Sheet—EMW-Series Two-Stage R410a

Installation Site		Startup Date	Installer	
City			Company	
Province		Check boxes unless asked to record data. Circle data units.	Model	
Country			Serial #	
Homeowner Name		Homeowner Phone #		

PRE-START INSPECTION

Indoor and Zone Loops (Hydronic)	All shut-off valve are open (full flow available)					
	Loop is full and purged of air					
	Antifreeze type					
	Antifreeze concentration		% Volume	% Weight		
	Loop static pressure		PSI	kPa		
Ground Loop System	All shut-off valve are open (full flow available)					
	Loop is full and purged of air					
	Antifreeze type					
	Antifreeze concentration		% Volume	% Weight		
	Loop static pressure		PSI	kPa		
Ground Water System	Water Valve installed in return line					
	Flow control installed in return line					
Domestic Hot Water	All shut-off valves are open					
	Lines are full and purged					
	Desuperheater pump wire is disconnected					
Electrical	High voltage connections are correct and securely fastened					
	Circuit breaker (or fuse) size and wire gauge for Heat Pump		A		Ga.	
	Circulator pump voltages (Outdoor 1, Outdoor 2)		V		V	
	Low voltage connections are correct and securely fastened					

STARTUP DATA

Preparation	Voltage across L1 and L2, L1 and L3, L2 and L3					VAC
	Green Light is ON					
Heating Mode (10 minutes)	Suction Pressure / Discharge Pressure			psig	kPa	
	Outdoor In (Supply In), Outdoor Out (Supply Out), and Delta T	In		Out	°F	°C
	Outdoor Flow	Igpm	USgpm	L/s		
	Compressor L1 (black wire) current	A				
	Heating aquastat setpoint and discharge pressure at cycle end	°F	°C		psig	kPa
	Domestic Hot Water functioning					
	Yellow light is ON. Electric element L1 current draw		A			
Cooling Mode (10 minutes) (HACW only)	Suction Pressure / Discharge Pressure			psig	kPa	
	Outdoor In (Supply In), Outdoor Out (Supply Out), and Delta T	In		Out	°F	°C
	Cooling aquastat setpoint and suction pressure at cycle end	°F	°C		psig	kPa
	Heating S1 Setpoint, S1 Delta, S2 Setpoint, S2 Delta				°F	°C
Final Aquastat Settings	Cooling S1 Setpoint, S1 Delta, S2 Setpoint, S2 Delta				°F	°C

Date:		Startup Personnel Signature:		Witness/Site Signature:	
--------------	--	-------------------------------------	--	--------------------------------	--

A total of three copies are required, one for the site, one for the installer/startup and one to be sent to Maritime Geothermal Ltd.

General Maintenance

GENERAL MAINTENANCE SCHEDULE		
Item	Interval	Procedure
Contactor	1 year	Inspect for pitted or burned points. Replace if necessary.
Heat exchanger	As required*	Clean as per HEAT EXHCANGER FLUSING PROCEDURE below.
Circulators & Valves	1 year	Inspect for leaks.

***Generally not required for closed loop systems. Whenever system performance is reduced for open loop.**

COAXIAL HEAT EXCHANGER FLUSHING PROCEDURE—GROUNDWATER	
STEP 1	Isolate the heat exchanger by closing the valves in the IN and OUT ports to the heat exchanger.
STEP 2	Blow out the heat exchanger into a clean 5 gallon bucket using compressed air.
STEP 3	If a purge cart is not available, use a 5 gallon plastic bucket, a circulator and some plastic piping to create a makeshift pump system. Connect a the inlet and outlet to the heat exchanger ports.*
STEP 4	Place 2 gallons of RYDLYME in the purge cart (or bucket). Circulate the fluid through the heat exchanger for at least 2 hours (3 recommended).
STEP 5	Disconnect the purge system dispose of the solution. RYDLYME is non-toxic and biodegradable and as such can be poured down a drain.
STEP 6	Connect fresh water and a drain to the heat exchanger ports and flush the exchanger for several minutes.
STEP 7	Return the plumbing to its original configuration and open the IN and OUT valves. Operate the system and check for improved performance.

*Depending on the plumbing, there should be either unions or boiler drains for to access the heat exchanger.

COAXIAL HEAT EXCHANGER FLUSHING PROCEDURE—GROUND LOOP	
STEP 1	Isolate the heat exchanger by placing the pump module valves in the exchanger flushing position.
STEP 2	Connect a compressed air and a drain pipe to the pump module purge ports and blow the anti-freeze solution into a clean 5 gallon bucket.
STEP 3	Connect a purge cart to the pump module purge ports.
STEP 4	Place 2 gallons of RYDLYME in the purge cart. Circulate the fluid through the heat exchanger for at least 2 hours (3 recommended).
STEP 5	Disconnect the purge cart and dispose of the solution. RYDLYME is non-toxic and biodegradable and as such can be poured down a drain. Clean the purge cart thoroughly.
STEP 6	Connect fresh water and a drain to the pump module purge ports and flush the exchanger for several minutes.
STEP 7	Blow the heat exchanger out with compressed air as per STEP 2 and dump the water down a drain.
STEP 8	Connect the purge cart to the pump module purge ports. Re-fill and purge the heat exchanger with as per standard procedures (the anti-freeze from STEP 2 can be re-used).
STEP 9	Disconnect the purge cart and set the pump module valves back to the original positions.
STEP 10	Operate the system and check for improved performance.

*Depending on the plumbing, there should be either unions or boiler drains for to access the heat exchanger.

Troubleshooting Guide

The following steps are for troubleshooting the geothermal heat pump. If the problem is with the domestic hot water or the auxiliary/backup electric heat, proceed to the relevant section at the end of the troubleshooting guide. Repair procedures and reference refrigeration circuit diagrams can be found at the end of the troubleshooting guide.

- STEP 1:** Verify that the display is present on the heating or cooling aquastat. If it is not present on either, proceed to POWER SUPPLY TROUBLE SHOOTING, otherwise proceed to STEP 2.
- STEP 2:** Remove the door and electrical box cover and check to see if there is a fault code on the control board. If there is, record the fault code. Turn the power off, wait 10 seconds and turn the power back on. Set the appropriate aquastat for a call for heating or cooling depending on the season.
- STEP 3:** If there is no signal present across Y and C of the safety board, proceed to the AQUASTAT TROUBLE SHOOTING section, otherwise proceed to STEP 4.
- STEP 4:** If a fault code appears once S1 displays on the aquastat and the compressor does not attempt to start, proceed to the FAULT CODE TROUBLESHOOTING section, otherwise proceed to STEP 5.
- STEP 5:** If no fault codes appear and the compressor does not attempt to start, attempts to start but cannot, starts hard, or starts but does not sound normal, proceed to the COMPRESSOR TROUBLESHOOTING section, otherwise proceed to STEP 6.
- STEP 6:** If the compressor starts and sounds normal, this means the compressor is OK and the problem lies elsewhere. Proceed to the OPERATION TROUBLESHOOTING section.
- STEP 7:** If the heat pump appears to be operating properly but no hot or cold water is making it to the zones proceed to the ZONE TROUBLESHOOTING section.
- NOTE:** To speed up the troubleshooting process, the Test Jumper on the safety board can be placed to the YES position to change the anti-short cycle timer to 5 seconds. **Be sure to set it back to NO when servicing is complete.**

POWER SUPPLY TROUBLESHOOTING			
Fault	Possible Cause	Verification	Recommended Action
No power to the heat pump	Disconnect switch open (if installed)	Verify disconnect switch is in the ON position.	Determine why the disconnect switch was opened, if all is OK close the switch.
	Fuse blown / Breaker Tripped.	At heat pump disconnect box, voltmeter shows 230VAC on the line side but not on the load side.	Reset breaker or replace fuse with proper size and type. (Time-delay type "D")
No display on either aquastat.	Transformer breaker tripped.	Breaker on transformer is sticking out.	Push breaker back in. If it trips again locate cause of short circuit and correct.
	Faulty transformer	Transformer breaker is not tripped, 230VAC is present across L1 and L3 of the compressor contactor but 24VAC is not present across R and C of the terminal strip.	Replace transformer.
	Faulty aquastat.	24VAC is present across 24V and COM of the aquastat but there is no display.	Replace aquastat.

AQUASTAT TROUBLESHOOTING

Fault	Possible Cause	Verification	Recommended Action
No signal to Y of safety board	Incorrect aquastat setup.	Aquastat does not indicate S1 on the display.	Correct the setup.
	Faulty aquastat.	No 24VAC between Stage 1 NO and COM of the aquastat when S1 is indicated on the aquastat display.	Replace aquastat.
Setting(s) not retained	Faulty aquastat	E2 error message. Can cause the unit to trip a safety control if the setting is too high or low.	Replace aquastat.

FAULT CODE TROUBLESHOOTING

Fault	Possible Cause	Verification	Recommended Action
Fault Code 1 (High Pressure Control)	Faulty High Pressure Control (open). * Must be a signal present on Y1 for this test. *HP pressures must be at static levels.	Verify if there is 24VAC across HP1 on the control board and C of the terminal strip, as well as HP2 and C.	Replace high pressure control if voltage is present on HP1 but not on HP2.
	Faulty control board.	24VAC is present across HP1 and C1, and HP2 and C, but no voltage is present across CC on the control board and C.	Replace control board.
Fault Code 2 (Low Pressure Control)	Faulty Low pressure control (open). * Must be a signal present on Y1 for this test. *HP pressures must be at static levels.	Verify if there is 24VAC across LP1 on the control board and C of the terminal strip, as well as LP2 and C.	Replace high pressure control if voltage is present on LP1 but not on LP1.
	Faulty control board.	24VAC is present across LP1 and C, and LP2 and C, but no voltage is present across CC on the control board and C.	Replace control board.
	Unit out of refrigerant.	Check static refrigeration pressure of the unit for a very low value.	Locate the leak and repair it. Spray nine, a sniffer and dye are common methods of locating a leak.
Fault Code 3 (Flow Switch)	Flow switch jumper removed or faulty.	Verify jumper is in place between pins marked FLOW SWITCH.	Place a jumper if missing.
	Flow switch faulty. (Only if installed)	Verify 24VAC is present between each flow switch pin on the control board and the C terminal of the terminal strip while there is flow through the unit.	Replace flow switch if signal is not present at both terminals on the control board.
	Faulty control board.	24VAC is present across each FLOW SWITCH terminal and C, but not voltage is present across CC on the control board and C.	Replace control board.

COMPRESSOR TROUBLESHOOTING

Fault	Possible Cause	Verification	Recommended Action
Compressor will not start	Tripped or faulty compressor breaker	Reset if tripped. If not tripped verify that there is 230VAC across L1 and L3 of the compressor contactor.	Determine why breaker was tripped. Replace breaker if faulty.
	Faulty control board.	Measuring from C on the terminal strip, verify there is voltage at Y, HP1, HP2, LP1, LP2, and both flow pins but no voltage present at CC.	Replace control board.
	Faulty run capacitor. (Single phase only)	Check value with capacitance meter. Should match label on capacitor. Compressor will hum while trying to start and then trip its overload.	Replace if faulty.
	Loose or faulty wiring.	Check all compressor wiring, including inside compressor electrical box.	Fix any loose connections. Replace any damaged wires.
	Faulty compressor contactor.	Voltage on line side with contactor held closed, but no voltage on one or both terminals on the load side. Points pitted or burned. Or, 24VAC across coil but contactor will not engage.	Replace contactor.
	Thermal overload on compressor tripped.	Ohmmeter shows reading when placed across R and S terminals and infinity between C & R or C & S. A valid resistance reading is present again after the compressor has cooled down	Proceed to Operation Troubleshooting to determine the cause of the thermal overload trip.
	Burned out motor. (open winding)	Remove wires from compressor. Ohmmeter shows infinite resistance between any two terminals Note: Be sure compressor overload has had a chance to reset. If compressor is hot this may take several hours.	Replace the compressor.
	Burned out motor. (shorted windings)	Remove wires from compressor. Resistance between any two terminals is below the specified value.	Replace the compressor.
	Motor shorted to ground.	Remove wires from compressor. Check for infinite resistance between each terminal and ground.	If any terminal to ground is not infinite replace the compressor.
Seized compressor due to locked or damaged mechanism.	Compressor attempts to start but trips its internal overload after a few seconds. (Run capacitor already verified)	Attempt to "rock" compressor free. If normal operation cannot be established, replace compressor.	
Compressor starts hard	Start capacitor faulty. (Single phase only)	Check with capacitance meter. Check for black residue around blowout hole on top of capacitor.	Replace if faulty. Remove black residue in electrical box if any.
	Potential Relay faulty (Single phase only)	Replace with new one and verify compressor starts properly.	Replace if faulty.
	Compressor is "tight" due to damaged mechanism.	Compressor attempts to start but trips its internal overload after a few seconds. Run capacitor has been verified already.	Attempt to "rock" compressor free. If normal operation cannot be established, replace compressor.
Compressor Stage 2 will not activate	Faulty Stage 2 module.	Verify if 24VAC is present across NO and C of Stage 2 of the aquastat that it powered up..	Replace module if signal is present. Check wiring if signal is not present.

OPERATION TROUBLESHOOTING - HEATING MODE

Fault	Possible Cause	Verification	Recommended Action
High Discharge Pressure	Aquastat set too high.	Verify aquastat setting	Lower aquastat setting to recommended value of 115°F (46°C)
	Low or no flow in heat exchanger to buffer tank circuit.	Check that isolation flanges and any ball valves are open. Verify 115VAC to pump. Check gauges for pressure drop.	Ensure flow path is unrestricted. Replace pump if faulty.
	TXV closed too far.	Verify superheat. It should be between 8-12°F (3-6°C). Superheat will be high if TXV is closed too far.	Adjust TXV to obtain 8-12°F (3-6°C) superheat.
	TXV stuck almost closed or partially blocked by foreign object.	Adjusting the TXV does not affect the superheat or the suction pressure.	Adjust the TXV all the way in and out a few times to loosen it. Replace TXV if this does not work.
	Filter-drier plugged	Feel each end of the filter-drier, it should be the same temperature. If there is a temperature difference then it is plugged. Also causes low suction pressure.	Replace filter-drier.
	Unit is overcharged. (Only possible if unit has been opened in the field and incorrectly charged).	High sub-cooling, low delta T across air coil.	Remove 1/2lb of refrigerant at a time and verify that the discharge pressure reduces.
Low Suction Pressure	Low or no Outdoor liquid flow	Delta T across the Outdoor Loop ports should be between 5-7°F (3-4°C), or compare pressure drop to the tables for the unit.	Determine the cause of the flow restriction and correct it. Verify pumps are working and sized correctly for ground loop systems. Verify well pump and water valve is working for ground water systems.
	Entering liquid temperature too cold.	Measure the entering liquid temperature. Most likely caused by under-sized ground loop.	Increase the size of the ground loop.
	Dirty or fouled coaxial heat exchanger. (typically for ground water, unlikely for ground loop)	Disconnect the water lines and check the inside of the pipes for scale deposits.	Have a qualified service technician backflush the coaxial exchanger.
	Indoor Loop entering liquid temperature too cold	Measure temperature. Should be above 60°F (15°C).	Restrict Indoor liquid flow temporarily until buffer tank comes up to temperature.
	TXV stuck almost closed or partially blocked by foreign object.	Adjusting the TXV does not affect the superheat or the suction pressure. TXV may be frosting up.	Adjust the TXV all the way in and out a few times to loosen it. Replace TXV if this does not work.
	Low refrigerant charge.	Entering liquid temperature, flow and entering air temperature are good but suction is low. Check static refrigeration pressure of the unit for a very low value.	Locate the leak and repair it. Spray nine, a sniffer and dye are common methods of locating a leak.
	Faulty compressor, not pumping.	Pressures change only slightly from static values when compressor is started.	Replace compressor.

OPERATION TROUBLESHOOTING - HEATING MODE

Fault	Possible Cause	Verification	Recommended Action
High Suction Pressure (may appear to not be pumping)	Leaking reversing valve.	Reversing valve is the same temperature on both ends of body, common suction line is warm, compressor is running hot.	Replace reversing valve.
	TXV adjusted too far open.	Verify superheat. It should be between 8-12°F (3-6°C). Superheat will be low if TXV is open too far.	Adjust TXV to obtain 8-12°F (3-6°C) superheat.
	TXV stuck open.	Adjusting the TXV does not affect the superheat or the suction pressure. Low super heat and discharge pressure.	Adjust the TXV all the way in and out a few times to loosen it. Replace TXV if this does not work.
Compressor frosting up	See Low Suction Pressure in this section.		
TXV frosting up	TXV stuck almost closed or partially blocked by foreign object.	Adjusting the TXV does not affect the superheat or the suction pressure.	Adjust the TXV all the way in and out a few times to loosen it. Replace TXV if this does not work.
Random high pressure trip (does not occur while on site)	Faulty compressor contactor.	Points pitted or burned. Contactor sometimes sticks causing the compressor to run without the fan, tripping the high pressure control.	Replace contactor.
	Intermittent Indoor Loop Circulator (heat exchanger to buffer tank).	Verify wiring is good	Correct the wiring or replace the circulator.

OPERATION TROUBLESHOOTING - COOLING MODE

Fault	Possible Cause	Verification	Recommended Action
Heating instead of cooling	Control wiring not set up properly or cooling select relays not functioning.	Verify that there is 24VAC across O and C of the terminal strip when calling for cooling.	Correct control wiring or replace relays.
	Faulty reversing valve solenoid coil.	Verify solenoid by removing it from the shaft while the unit is running. There should be a loud "whoosh" sound when it is removed.	Replace solenoid if faulty.
	Faulty reversing valve.	A click can be heard when the coil is energized but the unit continues to heat instead of cool.	Replace reversing valve.
High Discharge pressure	Low or no Outdoor liquid flow	Delta T across the Outdoor Loop ports should be between 8-12°F (4-7°C), or compare pressure drop to the tables for the unit.	Determine the cause of the flow restriction and correct it. Verify pumps are working for ground loop systems. Verify well pump and water valve is working for ground water systems.
	Entering liquid temperature too warm.	Most likely caused by undersized ground loop.	Verify the ground loop sizing. Increase the size of the ground loop if undersized.
	Dirty or fouled coaxial heat exchanger. (typically for ground water, unlikely for ground loop)	Disconnect the water lines and check the inside of the pipes for scale deposits.	Have a qualified service technician backflush the coaxial exchanger.

OPERATION TROUBLESHOOTING - COOLING MODE

Fault	Possible Cause	Verification	Recommended Action
High Discharge pressure (continued)	Unit is overcharged. (Only possible if unit has been opened in the field and incorrectly charged).	High sub-cooling, low delta T across water coil.	Remove 1/2lb of refrigerant at a time and verify that the discharge pressure reduces.
High Suction Pressure (may appear to not be pumping)	TXV adjusted too far open.	Verify superheat. It should be between 8-12°F (3-6°C). Superheat will be low if TXV is open too far.	Adjust TXV to obtain 8-12°F(3-6°C) superheat.
	TXV stuck open.	Adjusting the TXV does not affect the superheat or the suction pressure. Low super heat and discharge pressure.	Adjust the TXV all the way in and out a few times to loosen it. Replace TXV if this does not work.
	Leaking reversing valve.	Reversing valve is the same temperature on both ends of body, common suction line is warm, compressor is running hot.	Replace reversing valve.
Low Suction Pressure	Aquastat set too low.	Verify aquastat setting	Increase aquastat setting to recommended value of 45°F (7°C)
	Low or no flow in heat exchanger to buffer tank circuit.	Check that isolation flanges and any ball valves are open. Verify 115VAC to pump. Check gauges for pressure drop.	Ensure flow path is unrestricted. Replace pump if faulty.
	TXV stuck almost closed or partially blocked by foreign object.	Adjusting the TXV does not affect the superheat or the suction pressure. TXV may be frosting up.	Adjust the TXV all the way in and out a few times to loosen it. Replace TXV if this does not work.
	Low or no refrigerant charge.	Entering air temperature and airflow are good but suction is low. Check static refrigeration pressure of unit for very low value.	Locate the leak and repair it. Spray nine, a sniffer and dye are common methods of locating a leak.
	Faulty compressor, not pumping.	Pressures change only slightly from static values when compressor is started.	Replace compressor.
Compressor frosting up	See Low Suction Pressure in this section.		
TXV frosting up	TXV stuck almost closed or partially blocked by foreign object.	Adjusting the TXV does not affect the superheat or the suction pressure.	Adjust the TXV all the way in and out a few times to loosen it. Replace TXV if this does not work.
Random Low Pressure trip (does not occur while there)	Faulty compressor contactor.	Points pitted or burned. Contactor sometimes sticks causing the compressor to run without the fan, tripping the low pressure control.	Replace contactor.
	Intermittent Indoor Loop circulator (heat exchanger to buffer tank).	Verify wiring is good.	Correct the wiring or replace the circulator.

ELECTRIC HEAT TROUBLE SHOOTING

Fault	Possible Cause	Verification	Recommended Action
No Electric Heat	Tripped or faulty electric heat breaker.	Reset if tripped. If not tripped verify that there is 230VAC across L1 and L3 of the electric heat contactor.	Determine why breaker was tripped. Replace breaker if faulty.
	Insufficient Indoor Loop pressure.	Verify Indoor loop pressure. Must have at least 12PSIG to engage the safety pressure switch.	Increase Indoor Loop pressure.
	Faulty Timer. (Note: timer is set to 2 hours at factory).	Check timer setting. Adjust to minimum value to test timer. Verify 24VAC across each of the terminals to C on the terminals strip.	Replace timer if faulty.
	Faulty electric heat contactor.	Voltage on line side with contactor held closed, but no voltage on one or both terminals on the load side. Points pitted or burned. Or, 24VAC across coil but contactor will not engage.	Replace contactor.
	Faulty aquastat.	S2 is not showing on the display when it should be according to the settings and tank temperature.	Replace aquastat.
	Faulty aquastat.	S2 is showing on the display but 24VAC is not present across Stage 2 NO and COM in the aquastat.	Replace aquastat.
	Faulty elements.	With power off to the unit, measure the resistance across the T1 and T3 terminals of the electric heat contactor . Under 6 ohms = both elements good Infinity = both elements bad.	Replace the faulty elements.
Low Electric Heat	One faulty element.	With power off to the unit, measure the resistance across the T1 and T3 terminals of the electric heat contactor . 6 to 12ohms = one element bad	Measure each element individually to determine the faulty one and replace it.

ZONE TROUBLE SHOOTING

Fault	Possible Cause	Verification	Recommended Action
No hot/old water to individual zone	Faulty zone thermostat, wiring or zone valve head(s)	No 24VAC signal present across T and C of the heat pump terminal strip.	Locate the problem and correct it.
	Faulty zone valve(s)	Other zones work, 24VAC is present across T and C of the heat pump terminal strip but no hot/cold water reaches the zone.	Clean or replace zone valve(s)
No hot/cold water to any zones	Shut off valve closed.	Verify that all valves in the zone loops are open, including isolation valves at the zone circulator inside the unit.	Open any valves that are closed.
	Faulty zone circulator contactor.	24VAC is present across T and C of the heat pump terminal strip but the contactor does not energize. Or, contactor is energized but 115VAC is not present across the wire on the load terminal and ground.	Replace contactor.
	Faulty zone circulator.	115VAC is present across the wire on the load terminal of the zone circulator contactor and ground but circulator pump is not working.	Close isolation valves and remove circulator pump head. Verify operation of the impeller. Clean or replace if faulty.

DOMESTIC HOT WATER (DHW) TROUBLE SHOOTING

Fault	Possible Cause	Verification	Recommended Action
Insufficient hot water (Tank Problem)	Thermostat on hot water tank set too low. Should be set at 120°F. (140°F if required by local code)	Visually inspect the setting.	Readjust the setting to 120°F. (140°F if required by local code)
	Breaker tripped, or fuse blown in electrical supply to hot water tank.	Check both line and load sides of fuses. If switch is open determine why.	Replace blown fuse or reset breaker.
	Reset button tripped on hot water tank.	Check voltage at elements with multimeter.	Push reset button.
Insufficient hot water (Heat Pump Problem)	Circulator pump not operating.	Visually inspect the pump to see if shaft is turning. Use an amprobe to measure current draw.	Replace if faulty.
	Blockage or restriction in the water line or hot water heat exchanger.	Check water flow and power to pump. Check water lines for obstruction	Remove obstruction in water lines. Acid treat the domestic hot water coil.
	Faulty DHW cutout (failed open).	Check contact operation. Should close at 120°F and open at 140°F.	Replace DHW cutout if faulty.
	Heat pump not running enough hours to make sufficient hot water.	Note the amount of time the heat pump runs in any given hour.	Temporarily turn up the tank thermostats until colder weather creates longer run cycles.
Water is too hot.	Faulty DHW cutout (failed closed).	Check contact operation. Should close at 120°F and open at 140°F.	Replace DHW cutout if faulty.
	Thermostat on hot water tank set too high. Should be set at 120°F. (140°F if required by local code)	Visually inspect the setting.	Readjust the setting to 120°F. (140°F if required by local code)

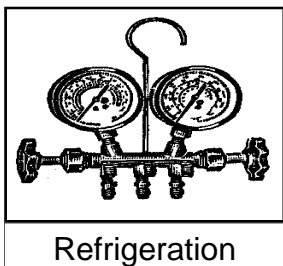

Refrigeration



In-line Flowmeter

Trouble Shooting Tools

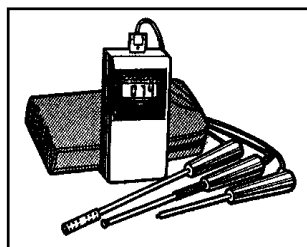

Digital

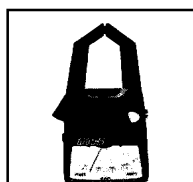

Multimeter - Voltmeter /

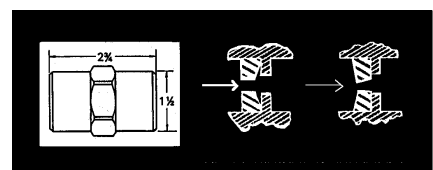

Dole flow control Valve

The Dole® flow control is a simple, self-cleaning device designed to deliver a constant volume of water from any outlet whether the pressure is 15 psig or as high as 125 psi. The controlling mechanism consists of a flexible orifice that varies its area inversely with pressure so that a constant flow is maintained.

REPAIR PROCEDURES

PUMP DOWN PROCEDURE

STEP 1	Connect the refrigerant recovery unit to the heat pump service ports via a refrigeration charging manifold and to a recovery tank as per the instructions in the recovery unit manual. If there was a compressor burn out, the refrigerant cannot be reused and must be disposed of according to local codes.
STEP 2	All water coil heat exchangers must either have full flow or be completely drained of fluid before recovery begins. Failure to do so can freeze and rupture the heat exchanger, voiding its warranty. (Note that this does not apply to double wall domestic hot water exchangers (desuperheater coils))
STEP 3	Ensure all hose connections are properly purged of air. Start the refrigerant recovery as per the instructions in the recovery unit manual.
STEP 4	Allow the recovery unit suction pressure to reach a vacuum. Once achieved, close the charging manifold valves. Shut down, purge and disconnect the recovery unit as per the instructions in its manual. Ensure the recovery tank valve is closed before disconnecting the hose to it.
STEP 5	Connect a nitrogen tank to the charging manifold and add nitrogen to the heat pump until a positive pressure of 5-10PSIG is reached. This prevents air from being sucked into the unit by the vacuum when the hoses are disconnected.
STEP 6	The heat pump is now ready for repairs. Always ensure nitrogen is flowing through the system during any soldering procedures to prevent soot buildup inside the pipes. Maritime Geothermal Ltd. recommends replacing the liquid line filter-drier anytime the refrigeration system has been exposed to the atmosphere.

VACUUM AND CHARGING PROCEDURE

STEP 1	After completion of repairs and nitrogen pressure testing, the refrigeration circuit is ready for vacuuming.
STEP 2	Release the refrigerant circuit pressure and connect the vacuum pump to the charging manifold. Start the vacuum pump and open the charging manifold valves. Vacuum until the vacuum gauge remains at less than 500 microns for at least 1 minute with the vacuum pump valve closed.
STEP 3	Close the charging manifold valves then shut off and disconnect the vacuum pump. Place a refrigerant tank with the proper refrigerant on a scale and connect it to the charging manifold. Purge the hose to the tank.
STEP 4	Weigh in the appropriate amount of refrigerant through the low pressure (suction) service port. Refer to the label on the unit or TABLE 10 - Refrigerant Charge Chart for the proper charge amount.
STEP 5	If the unit will not accept the entire charge, the remainder can be added through the low pressure service port after the unit has been restarted.

REPLACEMENT PROCEDURE FOR A COMPRESSOR BURN-OUT

STEP 1	Pump down the unit as per the Pump Down Procedure above.
STEP 2	Replace the compressor. Replace the liquid line filter-drier.
STEP 3	Vacuum the unit until it remains under 500 microns for several minutes with the vacuum pump valve closed.
STEP 4	Charge the unit and operate it for continuously for 2 hours. Pump down the unit and replace the filter-drier. Vacuum the unit until it remains under 500 microns for several minutes with the vacuum pump valve closed.
STEP 5	Charge the unit (refrigerant can be re-used) and operate it for 2-3 days. Pump down the unit and replace the filter-drier.
STEP 6	Charge the unit (refrigerant can be re-used) and operate it for 2 weeks. Pump down the unit and replace the filter-drier.
STEP 7	Charge the unit a final time. Unit should now be clean and repeated future burn-outs can be avoided.

EMW-HAC* Series Refrigeration Circuit Heating Mode

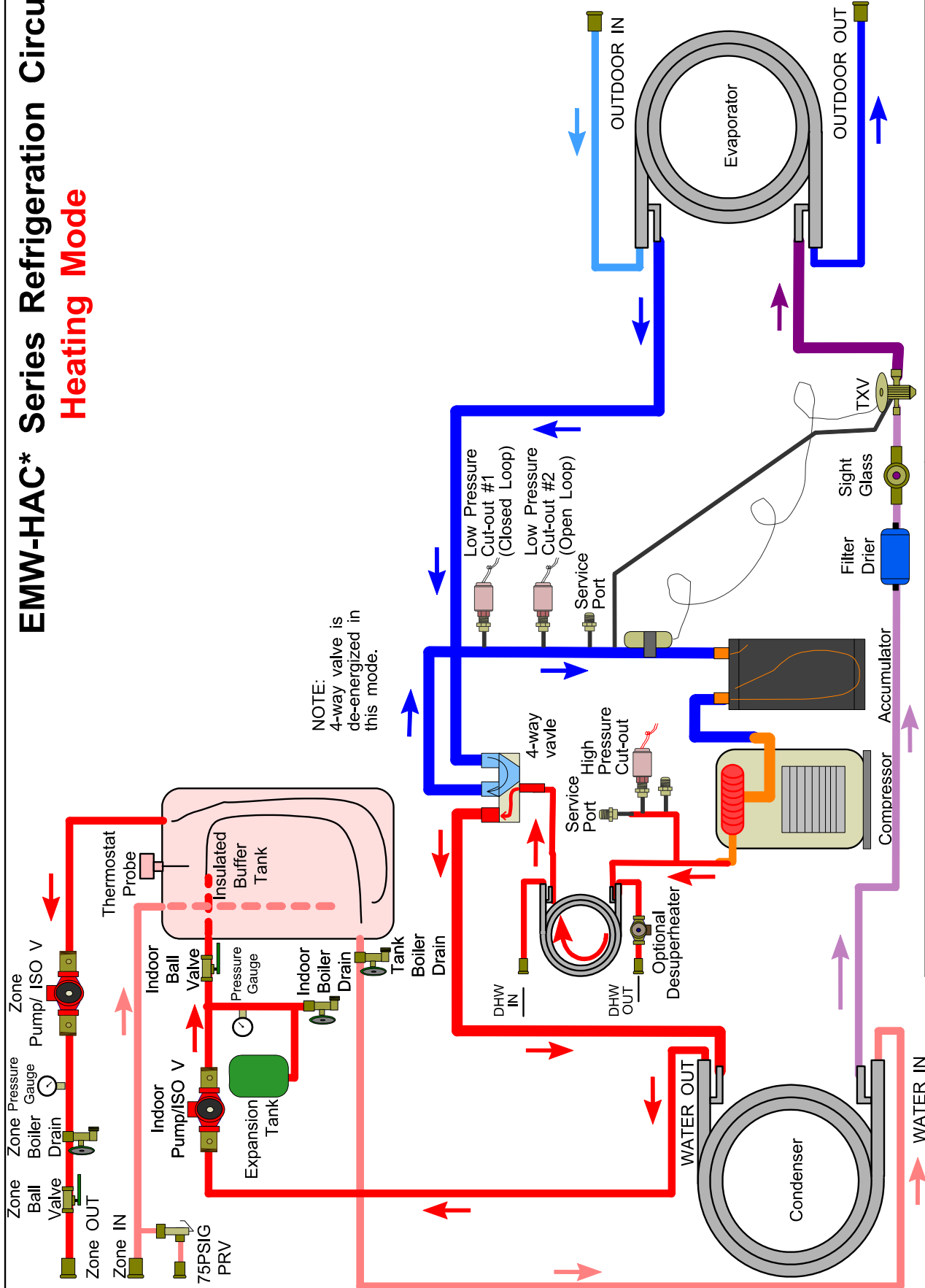

Drawn By	Chris Geddes	Date	12 JUN 09
Checked By	Chris Geddes	Date	12 JUN 09
Approved By (ENG)	Chris Geddes	Date	12 JUN 09
Approved By (MFG)	Chris Geddes	Date	12 JUN 09
Approved By		Date	

ECO #	IMPL BY	APVD BY	DATE
02	C. GEDDES	C. GEDDES	07 MAY 12
01	C. GEDDES	C. GEDDES	12 JUN 09

170 Plantation Rd. Pelletodiac, NB E4Z 6H4	
MARITIME GEOTHERMAL LTD.	
Drawing Name EMW-HAC*-Series Refrigeration	
Circuit Diagram - Heating Mode	
Size	A
Drawing Number	001047RCD
REV	02
SHEET	1 of 1

EMW-HAC* Series Refrigeration Circuit Cooling Mode

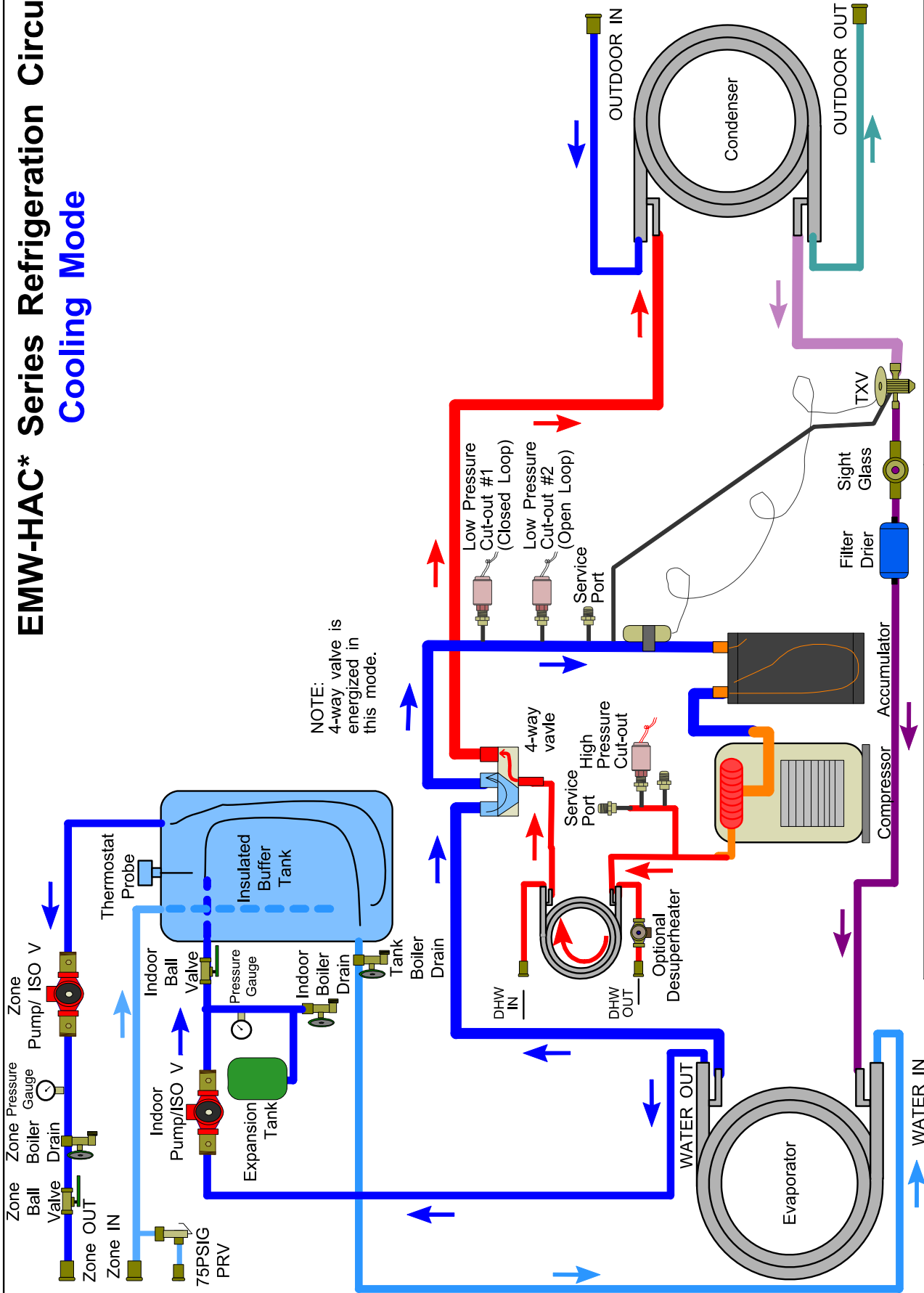

NOTE:
4-way valve is energized in this mode.

Drawn By	Chris Geddes	Date	12 JUN 09
Checked By	Chris Geddes	Date	12 JUN 09
Approved By	Chris Geddes	(ENG) Date	12 JUN 09
Approved By	Chris Geddes	(MFG) Date	

02	000198	C. GEDDES	07 MAY 12	DATE
01	Initial Release	C. GEDDES	12 JUN 09	DATE
REV	ECO #	IMPL BY	APVD BY	DATE

MARITIME GEOTHERMAL LTD. Pelticoctec, NB E5Z 6H4	
Drawing Name	EMW-HAC*-Series Refrigeration
Size	Circuit Diagram - Cooling Mode
REV	02
SHEET	1 of 1

Model Specific Information

This section provides general information particular to each model. For complete specifications please see the specifications document for the desired model.

REFRIGERANT CHARGE CHART

SIZE	Lbs.	kg
45	7.0	3.2
55	7.0	3.2
65	8.0	3.6
75	9.0	4.1
80	10.0	4.5
System contains POE oil.		

SHIPPING INFORMATION

MODEL	WEIGHT Lbs. (kg)	DIMENSIONS in (cm)		
		L	W	H
45	TBD	44 (112)	36 (91)	38 (96)
55	750 (340)	44 (112)	36 (91)	38 (96)
65	TBD	44 (112)	36 (91)	38 (96)
75	855 (388)	44 (112)	36 (91)	38 (96)
80	TBD	44 (112)	36 (91)	38 (96)

STANDARD CAPACITY RATINGS

The tables below depict the results of standard capacity rating tests according to C13256-2, which is identical to ISO13256-2. Stage 1 values do not apply to single stage units. Refer to the [Electrical Tables](#) to determine which models are single stage.

EWT 104°F (40°C)							STAGE 1 - ELT 41°F (5°C) STAGE 2 - ELT 32°F (0°C)			
Model	Liquid Flow (Outdoor & Indoor)			Outdoor Pressure Drop		Mode	Input Energy Watts	Capacity		COP _H W/W
	IGPM	USGPM	L/s	PSI	kPA			BTU/Hr	kW	
45	8	9.6	0.61	4.3	29.5	Stage 1	1,865	20,000	5.9	3.15
						Stage 2	2,580	27,000	7.9	3.07
55	10	12.0	0.76	4.5	30.7	Stage 1	3,685	30,200	8.8	3.29
						Stage 2	3,560	36,500	10.7	3.00
65	12	14.4	0.91	5.6	38.6	Stage 1	3,370	37,600	11.0	3.27
						Stage 2	4,380	45,800	13.4	3.07
75	14	16.8	1.06	5.7	39.5	Stage 1	3,905	45,600	13.3	3.42
						Stage 2	4,740	51,400	15.1	3.18
80	14	16.8	1.06	5.1	35.2	Stage 1	5,525	59,400	17.4	3.15

* 15% NaCl by Weight Ground Loop Fluid

EWT 104°F (40°C)							ELT 50°F (10°C)			
Model	Liquid Flow (Outdoor & Indoor)			Outdoor Pressure Drop		Mode	Input Energy Watts	Capacity		COP _H W/W
	IGPM	USGPM	L/s	PSI	kPA			BTU/Hr	kW	
45	8	9.6	0.61	3.7	25.6	Stage 1	1,815	23,500	6.9	3.78
						Stage 2	2,560	35,300	10.3	4.04
55	10	12.0	0.76	3.9	26.1	Stage 1	2,615	34,300	10.1	3.84
						Stage 2	3,660	47,400	13.9	3.79
65	12	14.4	0.91	4.9	33.0	Stage 1	3,390	42,900	12.6	3.71
						Stage 2	4,545	58,800	17.2	3.79
75	14	16.8	1.06	5.0	34.8	Stage 1	3,860	52,200	15.3	3.96
						Stage 2	4,860	66,300	19.4	4.00
80	14	16.8	1.06	4.6	32.0	Stage 1	5,630	78,200	22.9	4.07

Table 14 - Standard Capacity Ratings - Ground Loop Cooling* 60Hz										
EWT 53.6°F (12°C)						STAGE 1 - ELT 68°F (20°C) STAGE 2 - ELT 77°F (25°C)				
Model	Liquid Flow (Outdoor & Indoor)			Outdoor Pressure Drop		Mode	Input Energy	Capacity		COP _c
	IGPM	USGPM	L/s	PSI	kPA			Watts	BTU/Hr	
45	8	9.6	0.61	3.8	26.2	Stage 1	1,145	23,900	7.0	6.12
						Stage 2	2,025	32,100	9.4	4.64
55	10	12.0	0.76	4.0	27.6	Stage 1	1,720	34,000	10.0	5.79
						Stage 2	2,860	42,300	12.4	4.33
65	12	14.4	0.91	5.0	34.7	Stage 1	2,055	41,300	12.1	5.89
						Stage 2	3,345	51,500	15.1	4.51
75	14	16.8	1.06	5.1	35.2	Stage 1	2,605	48,200	14.0	5.42
						Stage 2	3,895	57,900	17.0	4.36
80	14	16.8	1.06	4.8	33.2					
						Stage 1	4,305	67,100	19.7	4.57

* 15% NaCl by Weight Ground Loop Fluid

Table 15 - Standard Capacity Ratings - Ground Water Cooling 60Hz										
EWT 53.6°F (12°C)						ELT 59°F (15°C)				
Model	Liquid Flow (Outdoor & Indoor)			Outdoor Pressure Drop		Mode	Input Energy	Capacity		COP _c
	IGPM	USGPM	L/s	PSI	kPA			Watts	BTU/Hr	
45	8	9.6	0.61	3.6	25.1	Stage 1	1,000	25,300	7.4	7.39
						Stage 2	1,700	35,100	10.3	6.05
55	10	12.0	0.76	3.8	26.0	Stage 1	1,480	35,300	10.3	6.97
						Stage 2	2,365	47,900	14.0	5.93
65	12	14.4	0.91	4.6	31.9	Stage 1	1,800	42,900	12.6	7.00
						Stage 2	2,785	57,200	16.8	6.02
75	14	16.8	1.06	4.8	33.4	Stage 1	2,350	51,300	15.0	6.40
						Stage 2	3,335	64,900	19.0	5.70
80	14	16.8	1.06	4.5	31.1					
						Stage 1	3,545	73,800	21.6	6.10

CAPACITY RATINGS

Heating Mode

EMW-45-HACW-P-1T						Nominal 3 ton				R410a 60 Hz					
Source Data (Outdoor Loop)						Power Consumption				Sink Data (Indoor Loop)					
ELT	Evap. Temp	Flow	LLT	Delta T	HAB	Total		Effective	COPh	EWT	Cond. Temp.	Flow	LWT	Delta T	Net Output
°F	°F	USGPM	°F	°F	BTU/Hr	Watts	Amps	Watts	W/W	°F	°F	USGPM	°F	°F	BTU/Hr
°C	°C	L/s	°C	°C	Watts					°C	°C	L/s	°C	°C	Watts
25.0	15	9.6	21.4	3.6	16,441	2,438	10.4	2,538	2.87	104.0	113	9.6	109.2	5.2	24,899
-3.9	-9.4	0.606	-5.9	2.0	4,817					40.0	45.0	0.606	42.9	2.9	7,295
31.0	20	9.6	27.0	4.0	18,025	2,478	10.6	2,577	3.03	104.0	114	9.6	109.5	5.5	26,617
-0.6	-6.7	0.606	-2.8	2.2	5,281					40.0	45.6	0.606	43.1	3.1	7,799
37.0	25	9.6	32.6	4.4	19,881	2,484	10.7	2,584	3.23	104.0	114	9.6	109.9	5.9	28,495
2.8	-3.9	0.606	0.4	2.4	5,825					40.0	45.6	0.606	43.3	3.3	8,349
43.0	30	9.6	38.0	5.0	22,752	2,459	10.7	2,558	3.58	104.0	114	9.6	110.5	6.5	31,280
6.1	-1.1	0.606	3.3	2.8	6,666					40.0	45.6	0.606	43.6	3.6	9,165
48.0	35	9.6	42.3	5.7	25,783	2,463	10.9	2,555	3.94	104.0	115	9.6	111.2	7.2	34,320
8.9	1.7	0.606	5.7	3.1	7,554					40.0	46.1	0.606	44.0	4.0	10,056
54.0	40	9.6	47.8	6.2	28,316	2,466	10.9	2,558	4.22	104.0	115	9.6	111.7	7.7	36,864
12.2	4.4	0.606	8.8	3.4	8,297					40.0	46.1	0.606	44.3	4.3	10,801
60.0	45	9.6	53.2	6.8	31,051	2,469	10.9	2,561	4.53	104.0	115	9.6	112.3	8.3	39,609
15.6	7.2	0.606	11.8	3.8	9,098					40.0	46.1	0.606	44.6	4.6	11,605
66.0	50	9.6	58.6	7.4	33,766	2,504	11.1	2,596	4.79	104.0	116	9.6	112.8	8.8	42,443
18.9	10.0	0.606	14.8	4.1	9,893					40.0	46.7	0.606	44.9	4.9	12,436

Compressor: ZPS30K4E-PFV

Cooling Mode

EMW-45-HACW-P-1T						Nominal 3 ton				R410a 60 Hz					
Source Data (Indoor Loop)						Power Consumption				Sink Data (Outdoor Loop)					
ELT	Evap. Temp	Flow	LLT	Delta T	HAB	Total		Effective	Efficiency	ELT	Cond. Temp.	Flow	LLT	Delta T	Rejection
°F	°F	USGPM	°F	°F	BTU/Hr	Watts	Amps	Watts	EER	°F	°F	USGPM	°F	°F	BTU/Hr
°C	°C	L/s	°C	°C	Watts				COPc	°C	°C	L/s	°C	°C	Watts
53.6	36	9.6	46.0	7.6	36,494	1,331	5.4	1,433	25.5	48	65	9.6	57.0	9.0	41,036
12.0	2.4	0.606	7.8	4.2	10,693				7.46	8.9	18.3	0.606	13.9	5.0	12,023
53.6	37	9.6	46.1	7.5	35,894	1,453	5.9	1,555	23.1	53	70	9.6	62.0	9.0	40,852
12.0	2.6	0.606	7.8	4.2	10,517				6.76	11.7	21.1	0.606	16.6	5.0	11,969
53.6	37	9.6	46.2	7.4	35,271	1,575	6.4	1,677	21.0	58	75	9.6	66.9	8.9	40,645
12.0	2.8	0.606	7.9	4.1	10,334				6.16	14.4	23.9	0.606	19.4	5.0	11,909
53.6	38	9.6	46.5	7.1	34,076	1,650	6.9	1,753	19.4	63	80	9.6	71.7	8.7	39,707
12.0	3.1	0.606	8.1	3.9	9,984				5.70	17.2	26.7	0.606	22.1	4.8	11,634
53.6	38	9.6	46.7	6.9	32,872	1,721	7.3	1,826	18.0	69	85	9.6	77.5	8.5	38,745
12.0	3.3	0.606	8.2	3.8	9,631				5.28	20.6	29.4	0.606	25.3	4.7	11,352
53.6	39	9.6	46.9	6.7	32,314	1,843	7.9	1,948	16.6	74	90	9.6	82.5	8.5	38,605
12.0	3.6	0.606	8.3	3.7	9,468				4.86	23.3	32.2	0.606	28.0	4.7	11,311
53.6	39	9.6	47.0	6.6	31,725	1,971	8.4	2,075	15.3	79	95	9.6	87.4	8.4	38,451
12.0	3.9	0.606	8.3	3.7	9,295				4.48	26.1	35.0	0.606	30.8	4.7	11,266
53.6	40	9.6	47.1	6.5	31,104	2,104	9.0	2,208	14.1	84	100	9.6	92.4	8.4	38,284
12.0	4.2	0.606	8.4	3.6	9,113				4.13	28.9	37.8	0.606	33.6	4.7	11,217

Compressor: ZPS30K4E-PFV

CAPACITY RATINGS - continued

Heating Mode

EMW-55-HACW-P-1T						Nominal 4 ton				R410a 60 Hz					
Source Data (Outdoor Loop)						Power Consumption				Sink Data (Indoor Loop)					
ELT	Evap. Temp	Flow	LLT	Delta T	HAB	Total		Effective	COPh	EWT	Cond. Temp.	Flow	LWT	Delta T	Net Output
°F	°F	USGPM	°F	°F	BTU/Hr	Watts	Amps	Watts	W/W	°F	°F	USGPM	°F	°F	BTU/Hr
°C	°C	L/s	°C	°C	Watts					°C	°C	L/s	°C	°C	Watts
25.0	15	12.0	21.3	3.7	21,372	3,379	14.6	3,509	2.76	104.0	117	12.0	109.5	5.5	33,085
-3.9	-9.4	0.757	-6.0	2.1	6,262					40.0	47.2	0.757	43.1	3.1	9,694
31.0	20	12.0	26.8	4.2	23,975	3,430	14.9	3,560	2.95	104.0	118	12.0	110.0	6.0	35,860
-0.6	-6.7	0.757	-2.9	2.3	7,025					40.0	47.8	0.757	43.3	3.3	10,507
37.0	25	12.0	32.3	4.7	27,024	3,439	14.9	3,569	3.20	104.0	118	12.0	110.5	6.5	38,942
2.8	-3.9	0.757	0.1	2.6	7,918					40.0	47.8	0.757	43.6	3.6	11,410
43.0	30	12.0	37.7	5.3	30,337	3,470	15.0	3,600	3.45	104.0	118	12.0	111.1	7.1	42,360
6.1	-1.1	0.757	3.2	3.0	8,889					40.0	47.8	0.757	43.9	3.9	12,411
48.0	35	12.0	42.1	5.9	33,660	3,539	15.2	3,657	3.68	104.0	119	12.0	111.7	7.7	45,918
8.9	1.7	0.757	5.6	3.3	9,862					40.0	48.3	0.757	44.3	4.3	13,454
54.0	40	12.0	47.4	6.6	37,525	3,543	15.2	3,661	3.98	104.0	119	12.0	112.3	8.3	49,798
12.2	4.4	0.757	8.6	3.7	10,995					40.0	48.3	0.757	44.6	4.6	14,591
60.0	45	12.0	52.7	7.3	41,696	3,547	15.3	3,666	4.32	104.0	119	12.0	113.0	9.0	53,984
15.6	7.2	0.757	11.5	4.1	12,217					40.0	48.3	0.757	45.0	5.0	15,817
66.0	50	12.0	58.0	8.0	45,852	3,592	15.5	3,711	4.60	104.0	120	12.0	113.7	9.7	58,293
18.9	10.0	0.757	14.4	4.5	13,434					40.0	48.9	0.757	45.4	5.4	17,080

Compressor: ZPS40K4E-PFV

Cooling Mode (Full Load)

EMW-55-HACW-P-1T						Nominal 4 ton				R410a 60 Hz					
Source Data (Indoor Loop)						Power Consumption				Sink Data (Outdoor Loop)					
ELT	Evap. Temp	Flow	LLT	Delta T	HAB	Total		Effective	Efficiency	ELT	Cond. Temp.	Flow	LLT	Delta T	Rejection
°F	°F	USGPM	°F	°F	BTU/Hr	Watts	Amps	Watts	EER	°F	°F	USGPM	°F	°F	BTU/Hr
°C	°C	L/s	°C	°C	Watts				COPc	°C	°C	L/s	°C	°C	Watts
53.6	37	12.0	45.2	8.4	50,203	1,910	8.5	2,025	24.8	47	70	12.0	57.0	10.0	56,723
12.0	2.6	0.757	7.3	4.7	14,709				7.26	8.3	21.1	0.757	13.9	5.5	16,620
53.6	37	12.0	45.4	8.2	49,282	2,051	9.1	2,166	22.7	52	75	12.0	61.9	9.9	56,284
12.0	2.7	0.757	7.4	4.6	14,440				6.67	11.1	23.9	0.757	16.6	5.5	16,491
53.6	37	12.0	45.5	8.1	48,320	2,194	9.7	2,309	20.9	57	80	12.0	66.8	9.8	55,807
12.0	2.8	0.757	7.5	4.5	14,158				6.13	13.9	26.7	0.757	19.3	5.4	16,351
53.6	37	12.0	45.9	7.7	46,140	2,310	10.3	2,425	19.0	62	85	12.0	71.5	9.5	54,023
12.0	3.0	0.757	7.7	4.3	13,519				5.58	16.7	29.4	0.757	21.9	5.3	15,829
53.6	38	12.0	46.2	7.4	44,119	2,425	10.9	2,557	17.3	67	90	12.0	76.2	9.2	52,397
12.0	3.3	0.757	7.9	4.1	12,927				5.06	19.4	32.2	0.757	24.6	5.1	15,352
54.1	38	12.0	46.9	7.2	43,075	2,574	11.6	2,706	15.9	72	95	12.0	81.1	9.1	51,861
12.3	3.4	0.757	8.3	4.0	12,621				4.66	22.2	35.0	0.757	27.3	5.1	15,195
53.6	39	12.0	46.6	7.0	42,250	2,729	12.3	2,861	14.8	77	100	12.0	86.0	9.0	51,564
12.0	3.7	0.757	8.1	3.9	12,379				4.33	25.0	37.8	0.757	30.0	5.0	15,108
53.6	39	12.0	46.7	6.9	41,455	2,891	13.0	3,022	13.7	82	105	12.0	91.0	9.0	51,321
12.0	4.1	0.757	8.2	3.8	12,146				4.02	27.8	40.6	0.757	32.8	5.0	15,037

Compressor: ZPS40K4E-PFV

CAPACITY RATINGS - continued

Heating Mode

EMW-65-HACW-P-1T						Nominal 5 ton				R410a 60 Hz					
Source Data (Outdoor Loop)						Power Consumption				Sink Data (Indoor Loop)					
ELT	Evap. Temp	Flow	LLT	Delta T	HAB	Total		Effective	COPh	EWT	Cond. Temp.	Flow	LWT	Delta T	Net Output
°F	°F	USGPM	°F	°F	BTU/Hr	Watts	Amps	Watts	W/W	°F	°F	USGPM	°F	°F	BTU/Hr
°C	°C	L/s	°C	°C	Watts					°C	°C	L/s	°C	°C	Watts
25.0	15	14.4	21.0	4.0	27,375	4,172	18.3	4,359	2.81	104.0	115	14.4	109.8	5.8	41,854
-3.9	-9.4	0.908	-6.1	2.2	8,021					40.0	46.1	0.908	43.2	3.2	12,263
31.0	20	14.4	26.5	4.5	30,571	4,187	18.4	4,375	3.02	104.0	115	14.4	110.3	6.3	45,103
-0.6	-6.7	0.908	-3.0	2.5	8,957					40.0	46.1	0.908	43.5	3.5	13,215
37.0	25	14.4	32.1	4.9	33,795	4,251	18.7	4,439	3.20	104.0	116	14.4	110.7	6.7	48,545
2.8	-3.9	0.908	0.0	2.7	9,902					40.0	46.7	0.908	43.7	3.7	14,223
43.0	30	14.4	37.4	5.6	38,187	4,288	18.7	4,476	3.47	104.0	116	14.4	111.4	7.4	53,064
6.1	-1.1	0.908	3.0	3.1	11,189					40.0	46.7	0.908	44.1	4.1	15,548
49.0	35	14.4	42.8	6.2	42,724	4,377	19.0	4,548	3.73	104.0	117	14.4	112.0	8.0	57,907
9.4	1.7	0.908	6.0	3.5	12,518					40.0	47.2	0.908	44.5	4.5	16,967
55.0	40	14.4	48.1	6.9	47,256	4,383	19.0	4,554	4.02	104.0	117	14.4	112.7	8.7	62,459
12.8	4.4	0.908	8.9	3.8	13,846					40.0	47.2	0.908	44.8	4.8	18,300
61.0	45	14.4	53.4	7.6	51,786	4,443	19.3	4,614	4.27	104.0	118	14.4	113.3	9.3	67,194
16.1	7.2	0.908	11.9	4.2	15,173					40.0	47.8	0.908	45.2	5.2	19,688
67.0	50	14.4	58.7	8.3	57,028	4,449	19.3	4,621	4.59	104.0	118	14.4	114.1	10.1	72,457
19.4	10.0	0.908	14.8	4.6	16,709					40.0	47.8	0.908	45.6	5.6	21,230

Compressor: ZPS51K4E-PFV

Cooling Mode (Full Load)

EMW-65-HACW-P-1T										R410a 60 Hz					
Source Data (Indoor Loop)						Power Consumption				Sink Data (Outdoor Loop)					
ELT	Evap. Temp	Flow	LLT	Delta T	HAB	Total		Effective	Efficiency	ELT	Cond. Temp.	Flow	LLT	Delta T	Rejection
°F	°F	USGPM	°F	°F	BTU/Hr	Watts	Amps	Watts	EER	°F	°F	USGPM	°F	°F	BTU/Hr
°C	°C	L/s	°C	°C	Watts				COPc	°C	°C	L/s	°C	°C	Watts
53.6	36	14.4	45.3	8.3	59,576	2,124	9.9	2,304	25.9	47	65	14.4	56.8	9.8	66,825
12.0	2.1	0.908	7.4	4.6	17,456				7.58	8.3	18.3	0.908	13.8	5.4	19,579
53.6	36	14.4	45.4	8.2	58,711	2,322	10.7	2,503	23.5	52	70	14.4	61.7	9.7	66,638
12.0	2.2	0.908	7.5	4.5	17,202				6.87	11.1	21.1	0.908	16.5	5.4	19,525
53.6	36.2	14.4	45.6	8.0	57,685	2,521	11.5	2,702	21.4	57	75	14.4	66.7	9.7	66,290
12.0	2.3	0.908	7.5	4.5	16,902				6.26	13.9	23.9	0.908	19.3	5.4	19,423
53.6	37	14.4	45.9	7.7	55,645	2,661	12.2	2,841	19.6	62	80	14.4	71.5	9.5	64,727
12.0	2.6	0.908	7.7	4.3	16,304				5.74	16.7	26.7	0.908	21.9	5.3	18,965
53.6	37	14.4	46.2	7.4	53,481	2,795	13.0	2,984	17.9	68	85	14.4	77.2	9.2	63,021
12.0	2.7	0.908	7.9	4.1	15,670				5.25	20.0	29.4	0.908	25.1	5.1	18,465
53.6	37	14.4	46.3	7.3	52,252	2,995	13.9	3,184	16.4	73	90	14.4	82.1	9.1	62,474
12.0	2.8	0.908	8.0	4.0	15,310				4.81	22.8	32.2	0.908	27.9	5.1	18,305
53.6	37	14.4	46.5	7.1	51,280	3,202	14.7	3,390	15.1	78	95	14.4	87.1	9.1	62,208
12.0	3.0	0.908	8.0	4.0	15,025				4.43	25.6	35.0	0.908	30.6	5.1	18,227
53.6	38	14.4	46.6	7.0	50,250	3,416	15.6	3,605	13.9	83	100	14.4	92.1	9.1	61,910
12.0	3.2	0.908	8.1	3.9	14,723				4.08	28.3	37.8	0.908	33.4	5.0	18,139

Compressor: ZPS51K4E-PFV

CAPACITY RATINGS - continued

Heating Mode

EMW-75-HACW-P-1T						Nominal 6 ton				R410a 60 Hz					
Source Data (Outdoor Loop)						Power Consumption				Sink Data (Indoor Loop)					
ELT	Evap. Temp	Flow	LLT	Delta T	HAB	Total		Effective	COPh	EWT	Cond. Temp.	Flow	LWT	Delta T	Net Output
°F	°F	USGPM	°F	°F	BTU/Hr	Watts	Amps	Watts	W/W	°F	°F	USGPM	°F	°F	BTU/Hr
°C	°C	L/s	°C	°C	Watts					°C	°C	L/s	°C	°C	Watts
28.0	15	16.8	23.8	4.2	33,649	4,442	20.7	4,685	3.07	104.0	113	16.8	109.9	5.9	49,160
-2.2	-9.4	1.060	-4.6	2.3	9,859					40.0	45.0	1.060	43.3	3.3	14,404
34.0	20	16.8	29.3	4.7	37,338	4,505	21.0	4,748	3.27	104.0	114	16.8	110.3	6.3	53,064
1.1	-6.7	1.060	-1.5	2.6	10,940					40.0	45.6	1.060	43.5	3.5	15,548
40.0	25	16.8	34.8	5.2	41,641	4,516	21.1	4,759	3.53	104.0	114	16.8	110.8	6.8	57,406
4.4	-3.9	1.060	1.5	2.9	12,201					40.0	45.6	1.060	43.8	3.8	16,820
46.0	30	16.8	40.2	5.8	46,389	4,550	21.1	4,793	3.81	104.0	114	16.8	111.4	7.4	62,270
7.8	-1.1	1.060	4.5	3.2	13,592					40.0	45.6	1.060	44.1	4.1	18,245
51.0	35	16.8	44.6	6.4	51,181	4,633	21.4	4,857	4.06	104.0	115	16.8	112.0	8.0	67,336
10.6	1.7	1.060	7.0	3.6	14,996					40.0	46.1	1.060	44.5	4.5	19,729
57.0	40	16.8	49.9	7.1	56,650	4,639	21.5	4,862	4.39	104.0	115	16.8	112.7	8.7	72,824
13.9	4.4	1.060	9.9	3.9	16,598					40.0	46.1	1.060	44.8	4.8	21,337
63.0	45	16.8	55.2	7.8	62,553	4,644	21.5	4,867	4.74	104.0	115	16.8	113.4	9.4	78,745
17.2	7.2	1.060	12.9	4.4	18,328					40.0	46.1	1.060	45.2	5.2	23,072
69.0	50	16.8	60.4	8.6	68,450	4,701	21.8	4,925	5.05	104.0	116	16.8	114.1	10.1	84,839
20.6	10.0	1.060	15.8	4.8	20,056					40.0	46.7	1.060	45.6	5.6	24,858

Compressor: ZPS60K4E-PFV

Cooling Mode

EMW-75-HACW-P-1T						Nominal 6 ton				R410a 60 Hz					
Source Data (Indoor Loop)						Power Consumption				Sink Data (Outdoor Loop)					
ELT	Evap. Temp	Flow	LLT	Delta T	HAB	Total		Effective	Efficiency	ELT	Cond. Temp.	Flow	LLT	Delta T	Rejection
°F	°F	USGPM	°F	°F	BTU/Hr	Watts	Amps	Watts	EER	°F	°F	USGPM	°F	°F	BTU/Hr
°C	°C	L/s	°C	°C	Watts				COPc	°C	°C	L/s	°C	°C	Watts
53.6	36	16.8	45.5	8.1	67,861	2,627	12.1	2,860	23.7	49	65	16.8	58.6	9.6	76,828
12.0	2.4	1.060	7.5	4.5	19,883				6.95	9.4	18.3	1.060	14.8	5.3	22,510
53.6	37	16.8	45.7	7.9	66,602	2,824	13.0	3,057	21.8	54	70	16.8	63.6	9.6	76,241
12.0	2.5	1.060	7.6	4.4	19,514				6.38	12.2	21.1	1.060	17.5	5.3	22,338
53.6	37	16.8	45.8	7.8	65,298	3,022	13.8	3,254	20.1	59	75	16.8	68.5	9.5	75,610
12.0	2.6	1.060	7.7	4.3	19,132				5.88	15.0	23.9	1.060	20.3	5.3	22,154
53.6	37	16.8	46.1	7.5	62,772	3,160	14.6	3,393	18.5	64	80	16.8	73.2	9.2	73,557
12.0	2.7	1.060	7.8	4.2	18,392				5.42	17.8	26.7	1.060	22.9	5.1	21,552
53.6	37	16.8	46.4	7.2	60,359	3,294	15.5	3,535	17.1	69	85	16.8	78.0	9.0	71,602
12.0	2.8	1.060	8.0	4.0	17,685				5.00	20.6	29.4	1.060	25.5	5.0	20,979
53.6	37	16.8	46.6	7.0	59,076	3,494	16.4	3,735	15.8	74	90	16.8	82.9	8.9	71,002
12.0	2.9	1.060	8.1	3.9	17,309				4.63	23.3	32.2	1.060	28.3	4.9	20,803
53.6	37	16.8	46.7	6.9	57,621	3,701	17.3	3,942	14.6	79	95	16.8	87.8	8.8	70,252
12.0	3.0	1.060	8.2	3.8	16,883				4.28	26.1	35.0	1.060	31.0	4.9	20,584
53.6	38	16.8	46.9	6.7	56,226	3,915	18.3	4,156	13.5	84	100	16.8	92.7	8.7	69,589
12.0	3.1	1.060	8.3	3.7	16,474				3.96	28.9	37.8	1.060	33.7	4.8	20,389

Compressor: ZPS60K4E-PFV

CAPACITY RATINGS - continued

Heating Mode

EMW-80-HACW-P-1S						Nominal 6 ton				R410a 60 Hz					
Source Data (Outdoor Loop)						Power Consumption				Sink Data (Indoor Loop)					
ELT	Evap. Temp	Flow	LLT	Delta T	HAB	Total		Effective	COPh	EWT	Cond. Temp.	Flow	LWT	Delta T	Net Output
°F	°F	USGPM	°F	°F	BTU/Hr	Watts	Amps	Watts	W/W	°F	°F	USGPM	°F	°F	BTU/Hr
°C	°C	L/s	°C	°C	Watts					°C	°C	L/s	°C	°C	Watts
24.0	15	16.8	19.8	4.2	33,739	5,313	27.8	5,511	2.77	104.0	113	16.8	110.2	6.2	52,124
-4.4	-9.4	1.060	-6.8	2.3	9,885					40.0	45.0	1.060	43.4	3.4	15,272
30.0	20	16.8	25.1	4.9	38,715	5,343	28.0	5,541	3.02	104.0	114	16.8	110.8	6.8	57,201
-1.1	-6.7	1.060	-3.8	2.7	11,343					40.0	45.6	1.060	43.8	3.8	16,760
36.0	25	16.8	30.5	5.5	43,953	5,369	28.1	5,568	3.29	104.0	115	16.8	111.4	7.4	62,530
2.2	-3.9	1.060	-0.8	3.1	12,878					40.0	46.1	1.060	44.1	4.1	18,321
42.0	30	16.8	35.7	6.3	50,073	5,420	28.2	5,618	3.59	104.0	116	16.8	112.2	8.2	68,823
5.6	-1.1	1.060	2.1	3.5	14,671					40.0	46.7	1.060	44.6	4.6	20,165
48.0	35	16.8	40.9	7.1	56,672	5,467	28.2	5,652	3.92	104.0	117	16.8	113.0	9.0	75,575
8.9	1.7	1.060	4.9	3.9	16,605					40.0	47.2	1.060	45.0	5.0	22,143
54.0	40	16.8	46.1	7.9	63,075	5,484	28.3	5,669	4.24	104.0	118	16.8	113.8	9.8	82,036
12.2	4.4	1.060	7.8	4.4	18,481					40.0	47.8	1.060	45.4	5.4	24,036
60.0	45	16.8	51.2	8.8	69,906	5,497	28.3	5,682	4.58	104.0	119	16.8	114.6	10.6	88,911
15.6	7.2	1.060	10.7	4.9	20,482					40.0	48.3	1.060	45.9	5.9	26,051
66.0	50	16.8	56.3	9.7	77,204	5,506	28.3	5,690	4.96	104.0	120	16.8	115.5	11.5	96,238
18.9	10.0	1.060	13.5	5.4	22,621					40.0	48.9	1.060	46.4	6.4	28,198

Compressor: ZP70KWE-PFV

Cooling Mode

EMW-80-HACW-P-1S						Nominal 6 ton				R410a 60 Hz					
Source Data (Indoor Loop)						Power Consumption				Sink Data (Outdoor Loop)					
ELT	Evap. Temp	Flow	LLT	Delta T	HAB	Total		Effective	Efficiency	ELT	Cond. Temp.	Flow	LLT	Delta T	Rejection
°F	°F	USGPM	°F	°F	BTU/Hr	Watts	Amps	Watts	EER	°F	°F	USGPM	°F	°F	BTU/Hr
°C	°C	L/s	°C	°C	Watts				COPc	°C	°C	L/s	°C	°C	Watts
53.6	34	16.8	41.6	9.0	75,315	2,540	15.8	2,726	27.6	45	65	16.8	55.5	10.5	83,982
12.0	1.0	1.060	5.3	5.0	22,067				8.09	7.2	18.3	1.060	13.1	5.8	24,607
53.6	34	16.8	41.7	8.9	74,294	2,744	16.8	2,931	25.3	50	70	16.8	60.5	10.5	83,660
12.0	1.1	1.060	5.4	4.9	21,768				7.43	10.0	21.1	1.060	15.8	5.8	24,512
53.6	34	16.8	41.9	8.7	73,148	2,951	17.8	3,137	23.3	55	75	16.8	65.4	10.4	83,219
12.0	1.2	1.060	5.5	4.8	21,432				6.83	12.8	23.9	1.060	18.6	5.8	24,383
53.6	34	16.8	42.0	8.6	71,982	3,244	18.8	3,431	21.0	60	80	16.8	70.4	10.4	83,054
12.0	1.3	1.060	5.6	4.8	21,090				6.15	15.6	26.7	1.060	21.3	5.8	24,334
53.6	35	16.8	42.2	8.4	70,676	3,556	19.8	3,752	18.8	66	85	16.8	76.4	10.4	82,814
12.0	1.4	1.060	5.7	4.7	20,708				5.52	18.9	29.4	1.060	24.7	5.8	24,264
53.6	35	16.8	42.4	8.2	69,144	3,798	20.9	3,994	17.3	71	90	16.8	81.3	10.3	82,105
12.0	1.6	1.060	5.8	4.6	20,259				5.07	21.7	32.2	1.060	27.4	5.7	24,057
53.6	35	16.8	42.6	8.0	67,482	4,053	22.0	4,249	15.9	76	95	16.8	86.2	10.2	81,315
12.0	1.7	1.060	5.9	4.5	19,772				4.65	24.4	35.0	1.060	30.1	5.7	23,825
53.6	35	16.8	42.8	7.8	65,688	4,326	23.3	4,522	14.5	81	100	16.8	91.1	10.1	80,451
12.0	1.8	1.060	6.0	4.3	19,246				4.26	27.2	37.8	1.060	32.8	5.6	23,572

Compressor: ZP70KWE-PFV

ELECTRICAL TABLES

Table 16 - Heat Pump Electrical Information (230-1-60)

Model	Compressor		Internal Circulators	Electric Elements	Outdoor Circulators	FLA	MCA	Max Fuse/ Breaker	Wire Size
	RLA	LRA	Amps	Amps	Max A	Amps	Amps	Amps	ga
45	18.6	82	2.5	48	4.0	73.9	90.6	100	#3-3
55	23.6	96	2.5	48	5.0	79.9	97.8	125	#1-3
65	28.6	118	2.5	48	5.0	84.9	104.1	125	#1-3
75	30.4	150	2.5	48	5.0	86.7	106.3	125	#1-3
80*	35.7	148	2.5	48	5.0	92.0	112.9	125	#1-3

* Single Stage unit

Table 17 - Heat Pump Electrical Information (208-3-60)

Model	Compressor		Internal Circulators	Electric Elements	Outdoor Circulators	FLA	MCA	Max Fuse/ Breaker	Wire Size
	RLA	LRA	Amps	Amps	Max A	Amps	Amps	Amps	ga
45	12.4	58	2.5	43	4.0	62.7	76.6	80	#4-4
55	15.0	88	2.5	43	5.0	66.3	80.8	100	#3-4
65	19.6	110	2.5	43	5.0	70.9	86.6	100	#3-4
75	21.2	123	2.5	43	5.0	72.5	88.6	100	#3-4
80*	25.0	149	2.5	43	5.0	76.3	93.3	100	#3-4

* Single Stage unit

Table 18 - Heat Pump Electrical Information (220-1-50)

Model	Compressor		Internal Circulators	Electric Elements	Outdoor Circulators	FLA	MCA	Max Fuse/ Breaker	Wire Size
	RLA	LRA	Amps	Amps	Max A	Amps	Amps	Amps	ga
45*	15.0	67	2.5	46	4.0	68.3	83.6	100	#3-2
55*	17.7	98	2.5	46	5.0	72.0	87.9	100	#3-2
65*	27.3	153	2.5	46	5.0	81.6	99.9	125	#1-2
75*	32.9	176	2.5	46	5.0	87.2	106.9	125	#1-2

* Single Stage unit

Table 19 - Heat Pump Electrical Information (380-3-50)

Model	Compressor		Internal Circulators	Electric Elements	Outdoor Circulators	FLA	MCA	Max Fuse/ Breaker	Wire Size
	RLA	LRA	Amps	Amps	Max A	Amps	Amps	Amps	ga
45	5.0	30	2.5	46	4.0	55.3	67.3	80	#4-4
55	7.1	43	2.5	46	5.0	58.4	70.9	80	#4-4
65	10.0	64	2.5	46	5.0	61.3	74.6	100	#3-4
75	10.9	64	2.5	46	5.0	62.2	75.7	100	#3-4
80*	11.8	74	2.5	46	5.0	63.1	76.8	100	#3-4

* Single Stage unit

ELECTRICAL DIAGRAMS (HAC* 230-1-60) - continued

EMW-Series Schematic Diagram 208/230-1-60 / Single/Two Stage Scroll Reversing

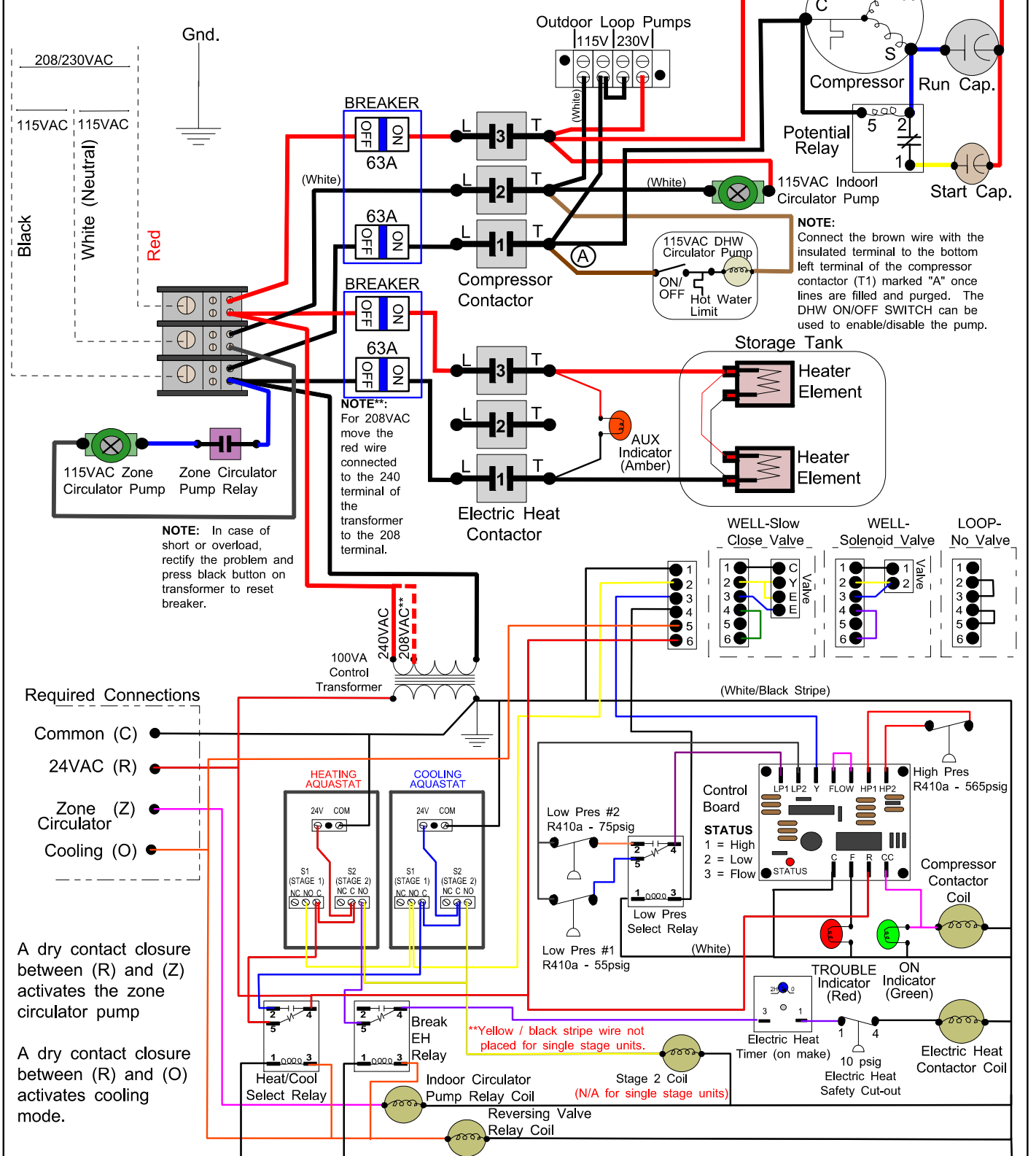

05	000208	C. GEDDES	C. GEDDES	07 MAY 12	Drawn By Chris Geddes	Date 10 MAY 07	MARITIME GEOTHERMAL LTD. 170 Plantation Rd. Petticoiac, NB E4Z 6H4
04	000198	C. GEDDES	C. GEDDES	07 MAY 12	Checked By Chris Geddes	Date 10 MAY 07	
03	000117	C. GEDDES	C. GEDDES	14 MAY 08	Approved By Chris Geddes	Date 10 MAY 07	
02	000110	C. GEDDES	C. GEDDES	25 FEB 08	Approved By (ENG)	Date 10 MAY 07	
01	Initial Release	C. GEDDES	C. GEDDES	10 MAY 07	Approved By (MFG)	Date	
REV	ECO #	IMPL BY	APVD BY	DATE	Approved By	Date	
Drawing Name EMW**-HAC*-**1*-** Schematic Diagram						Size Drawing Number A 000448SCH	
						REV	SHEET
						05	1 of 1

EMW-Series Electrical Box Diagram
208/230-1-60 / Single/Two Stage Scroll / Reversing

Low Voltage Wiring (24VAC)

- C - 24VAC Common
 - R - 24VAC Hot
 - Z - Zone Circulator
 - O - Cooling Mode (Reversing Valve)
- Connect R and Z to turn on the zone circulator.
- Connect R and O to switch to cooling mode.

Field
T'stat
Wiring
24VAC

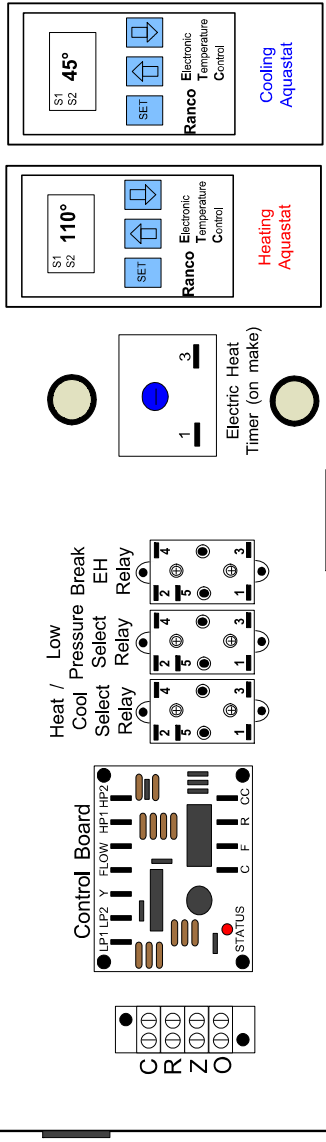

System Internal Voltages

- 208/230-1-60 Compressor
- 208/230-1-60 Hot Water Elements
- 115-1-60 Zone and Indoor Circulators
- 115-1-60 Domestic Hot Water Circulator

208/230VAC / 115VAC Outdoor Loop Circulators

- Connect 115VAC circulators to 115V (LEFT)
- Connect 230VAC circulators to 230V (RIGHT)
- Connect "Gnd" to Gnd. Lug

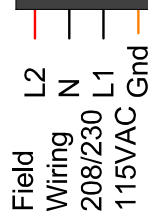

208-230/115VAC CONNECTIONS

Wire	Colour	Contactor
L2	Red	L3
N	White	L2
L1	Black	L1
Connect "Gnd" to Gnd. Lug		

IMPORTANT NOTE
FOR 208-1-60 POWER
Ensure red wire is connected to the 208 terminal on the transformer instead of the 230V terminal.

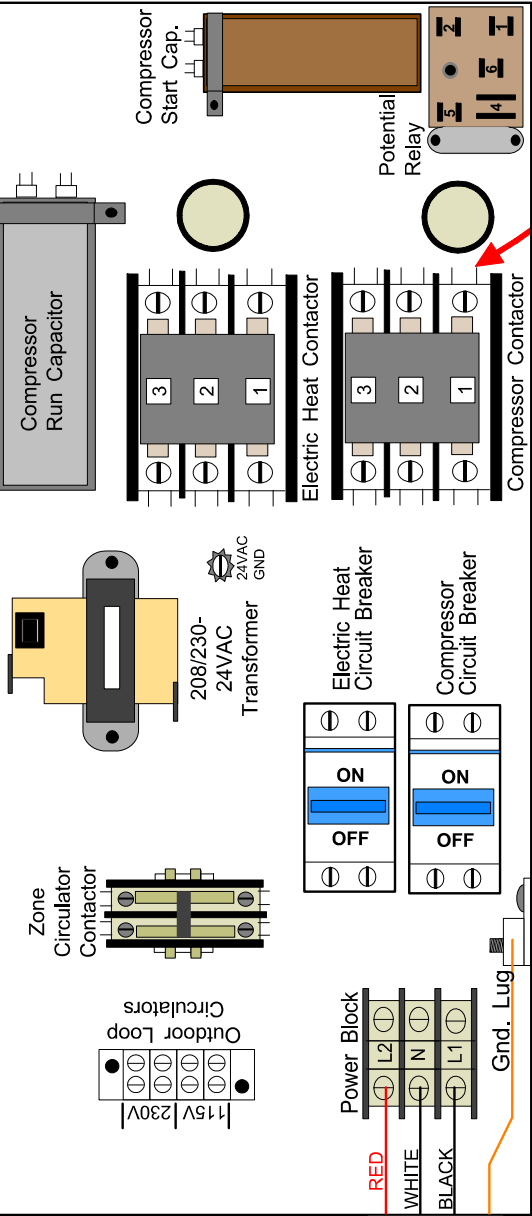

Heat Pump Electrical Service Requirements
208/230VAC Single Phase 60Hz (208/230-1-60)

Model Size	Min. Circuit Ampacity	MIn. Wire Gauge	TD Fuse or Breaker
45	91	#3-3	100
55	98	#3-3	100
65	104	#1-3	125
75	106	#1-3	125
80	113	#1-3	125

Domestic Hot water Circulator Pump Instructions (HACW only):

If heat pump is to be operated without the hot water circulator connected to the water tank and flooded with water, remove the brown wire with the insulated terminal located here. **This pump is water lubricated and must not be run dry.** Once connected the external ON/OFF switch may be used to temporarily turn the pump off.

04	000198	C. GEDDES	C. GEDDES	07 MAY 12	10 MAY 07
03	000117	C. GEDDES	C. GEDDES	14 MAY 08	10 MAY 07
02	000110	C. GEDDES	C. GEDDES	25 FEB 08	10 MAY 07
01	Initial Release	C. GEDDES	C. GEDDES	10 MAY 07	10 MAY 07
REV	ECO #	IMPL BY	APVD BY	DATE	DATE

Drawn By: Chris Gaddes
Checked By: Chris Gaddes
Approved By: Chris Gaddes

Size: A
Drawing Number: 000449ELB
REV: 04
SHEET: 1 of 1

MARITIME GEOTHERMAL LTD.
170 Plantation Rd.
Petitcodiac, NB
E4Z 6H4

CASE DETAILS

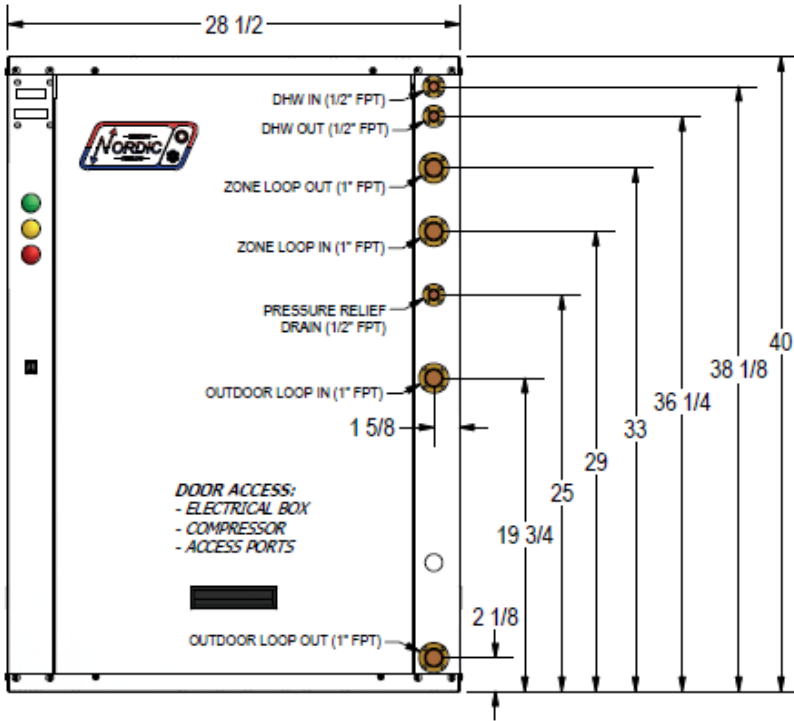

Front View

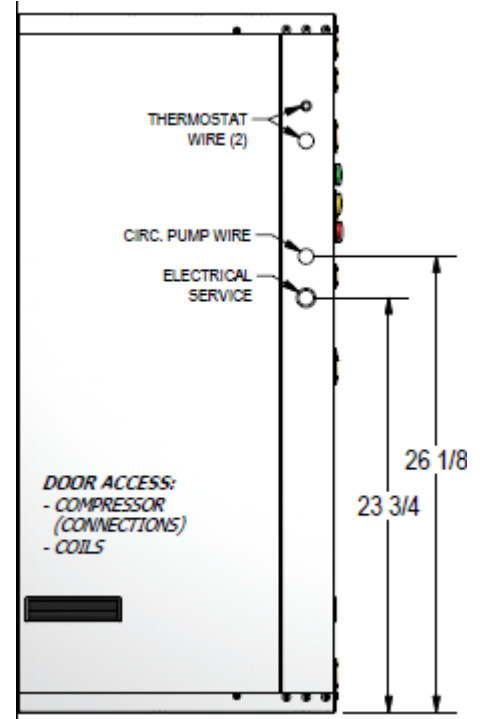

Left View

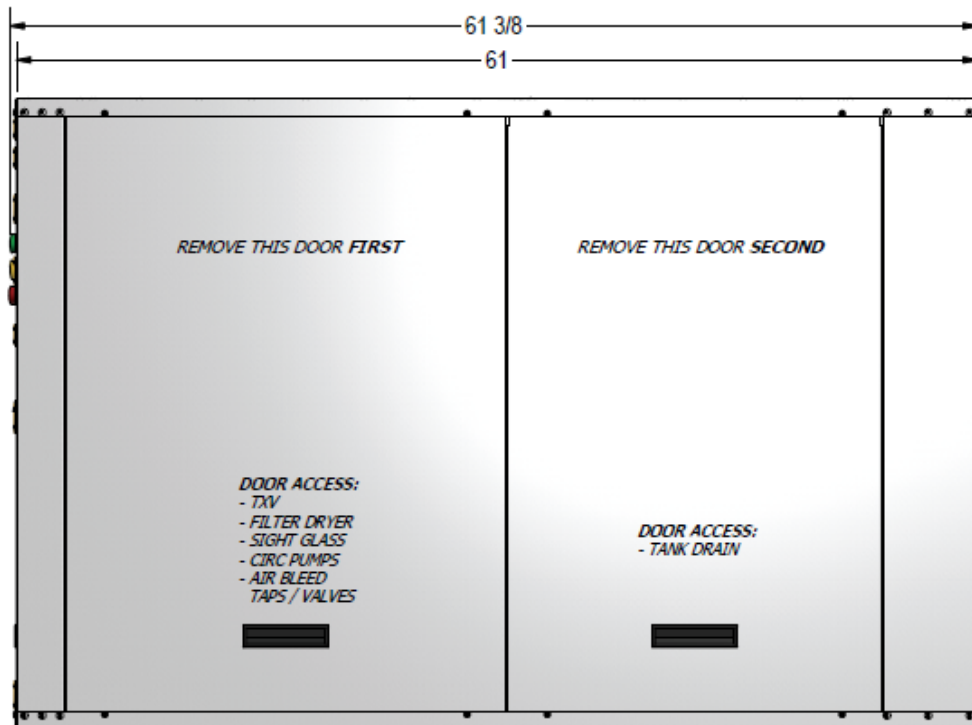

Right View

APPENDIX A - Control Board Specifications

Lockout Protection Module

- Anti-short cycle/lockout control
- Pressure/flow switch monitoring
- Alarm output during lockout
- 5-minute anti-short cycle delay (5-second test mode)
- LED fault codes for lockout status
- Test mode for reduced test time
- Conformally coated for moisture protection

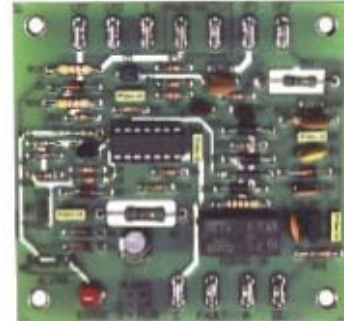

Mode of Operation

The control will begin the 5-minute time delay upon a Y call from the thermostat. After the time delay expires, the compressor contactor will be energized as long as the high and low pressure switches are closed. If either switch is open after the delay expires, the compressor will not energize. If either switch opens while the compressor is energized, it will de-energize immediately and begin the anti-short cycle delay. The compressor will not be allowed to turn on again until the anti-short cycle delay expires and both pressure switches are closed. The flow switch will have a 30-second bypass timer in which the control will ignore an open flow switch for the first 30 seconds. If the flow switch remains open after the 30-second bypass timer expires, the unit will de-energize the compressor and begin the anti-short cycle delay. If the control experiences three high pressure, low pressure, or flow switch faults in a 60-minute period, it will lockout the compressor and energize the fault output. A manual reset of power will be required to reset the lockout condition.

The control has a status LED to indicate which type of fault or lockout has occurred. If a high pressure fault or lockout occurs, the status LED will blink once. If a low pressure fault or lockout occurs, the status LED will blink twice. If a flow switch fault occurs, the status LED will blink three times.

Specifications

Input

- Voltage: 18 to 30 VAC
- Frequency: 50 to 60 Hz

Output

- CC
 - Type: Solid state (Triac)
 - Rating: 1 amp @ 30 VAC
- Fault
 - Type: Relay (SPDT) N.O.
 - Rating: 1 amp @ 30 VAC

Time Delay

- Anti-short cycle time: 5-minutes fixed $\pm 20\%$ (5-second test mode)

Mechanical

- Board dimensions: 3.5" x 3.25" x 1"
- Mounting: Surface mount using (4) #6 or #8 screws

Dimensions

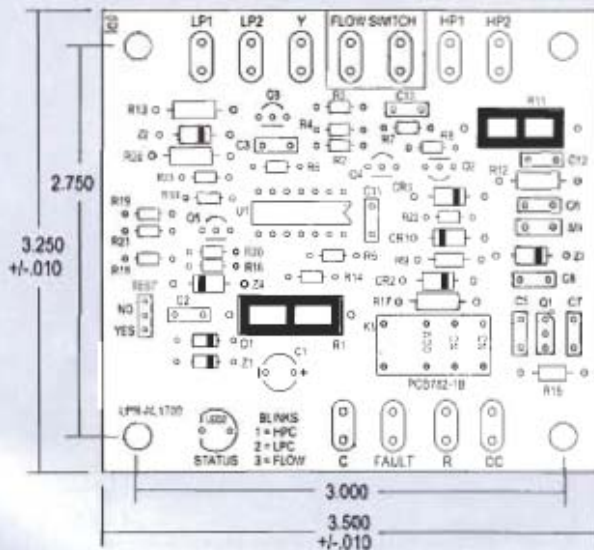

Wiring Diagram

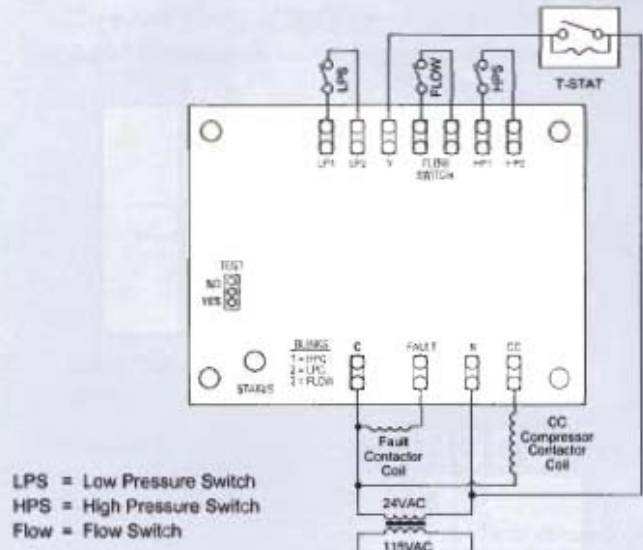

THIS PAGE INTENTIONALLY LEFT BLANK

THIS PAGE INTENTIONALLY LEFT BLANK

THIS PAGE INTENTIONALLY LEFT BLANK

LIMITED EXPRESS WARRANTY

It is expressly understood that unless a statement is specifically identified as a warranty, statements made by Maritime Geothermal Ltd., a corporation registered in New Brunswick, Canada, ("MG") or its representatives, relating to MG's products, whether oral, written or contained in any sales literature, catalogue or agreement, are not express warranties and do not form a part of the basis of the bargain, but are merely MG's opinion or commendation of MG's products.

EXCEPT AS SPECIFICALLY SET FORTH HEREIN, THERE IS NO EXPRESS WARRANTY AS TO ANY OF MG'S PRODUCTS. MG MAKES NO WARRANTY AGAINST LATENT DEFECTS. MG MAKES NO WARRANTY OF MERCHANTABILITY OF THE GOODS OR OF THE FITNESS OF THE GOODS FOR ANY PARTICULAR PURPOSE.

LIMITED EXPRESS RESIDENTIAL WARRANTY - PARTS

MG warrants its Residential Class products, purchased and retained in the United States of America and Canada, to be free from defects in material and workmanship under normal use and maintenance as follows:

- (1) Air conditioning, heating and/or heat pump units built or sold by MG ("MG Units") for five (5) years from the Warranty Inception Date (as defined below).
- (2) Thermostats, auxiliary electric heaters and geothermal pumping modules built or sold by MG, when installed with MG Units, for five (5) years from the Warranty Inception Date (as defined below).
- (3) Sealed refrigerant circuit components of MG Units (which components only include the compressor, refrigerant to air/water heat exchangers, reversing valve body and refrigerant metering device) for ten (10) years from the Warranty Inception Date (as defined below).
- (4) Other accessories and parts built or sold by MG, when installed and purchased with MG Units, for five (5) years from the date of shipment from MG.
- (5) Other accessories, when purchased separately, for (1) year from the date of shipment from MG.

The "Warranty Inception Date" shall be the date of original unit installation, as per the date on the installation Startup Record or six (6) months from date of unit shipment from MG, whichever comes first.

To make a claim under this warranty, parts must be returned to MG in Petitcodiac, New Brunswick, freight prepaid, no later than ninety (90) days after the date of the failure of the part. If MG determines the part to be defective and within MG's Limited Express Residential Warranty, MG shall, when such part has been either replaced or repaired, return such to a factory recognized distributor, dealer or service organization, freight prepaid. The warranty on any part repaired or replaced under warranty expires at the end of the original warranty period.

LIMITED EXPRESS RESIDENTIAL WARRANTY - LABOUR

This Limited Express Residential Labour Warranty shall cover the **labour** incurred by MG authorized service personnel in connection with the installation of a new or repaired warranty part that is covered by this Limited Express Residential Warranty only to the extent specifically set forth in the current **labour** allowance schedule "A" provided by MG's Warranty Department and only as follows:

- (1) MG Units for two (2) years from the Warranty Inception Date.
- (2) Thermostats, auxiliary electric heaters and geothermal pump modules built or sold by MG, when installed with MG Units, for two (2) years from the Warranty Inception Date.
- (3) Sealed refrigerant circuit components of MG Units (which components only include the compressor, refrigerant to air/water heat exchangers, reversing valve body and refrigerant metering device) for five (5) years from the Warranty Inception Date.

Labour costs are not covered by this Limited Express Residential Warranty to the extent they **exceed** the amount allowed under said allowance schedule, they are not specifically provided for in said allowance schedule, they are not the result of work performed by MG authorized service personnel, they are incurred in connection with a part not covered by this Limited Express Residential Warranty, or they are incurred more than the time periods set forth in this paragraph after the Warranty Inception Date.

This warranty does not cover and does not apply to:

- (1) Air filters, fuses, refrigerant, fluids, oil.
- (2) Products relocated after initial installation.
- (3) Any portion or component of any system that is not supplied by MG, regardless of the cause of the failure of such portion or component.
- (4) Products on which the unit identification tags or labels have been removed or defaced.
- (5) Products on which payment to MG, or to the owner's seller or installing contractor, is in default.
- (6) Products subjected to improper or inadequate installation, maintenance, repair, wiring or voltage conditions.
- (7) Products subjected to accident, misuse, negligence, abuse, fire, flood, lightning, unauthorized alteration, misapplication, contaminated or corrosive liquid or air supply, operation at abnormal air or liquid temperatures or flow rates, or opening of the refrigerant circuit by unqualified personnel.
- (8) Mold, fungus or bacteria damage
- (9) Corrosion or abrasion of the product.
- (10) Products supplied by others.
- (11) Products which have been operated in a manner contrary to MG's printed instructions.
- (12) Products which have insufficient performance as a result of improper system design or improper application, installation, or use of MG's products.
- (13) Electricity or fuel, or any increases or unrealized savings in same, for any reason whatsoever.

Except for the limited **labour** allowance coverage set forth above, MG is not responsible for:

- (1) The costs of fluids, refrigerant or system components **supplied by others**, or associated **labour** to repair or replace the same, which is incurred as a result of a defective part covered by MG's Limited Residential Warranty.
- (2) The costs of **labour**, refrigerant, materials or service incurred in diagnosis and removal of the defective part, or in obtaining and replacing the new or repaired part.
- (3) Transportation costs of the defective part from the installation site to MG, or of the return of that part if not covered by MG's Limited Express Residential Warranty.
- (4) The costs of normal maintenance.

This Limited Express Residential Warranty applies to MG Residential Class products manufactured on or after February 15, 2010. MG'S LIABILITY UNDER THE TERMS OF THIS LIMITED WARRANTY SHALL APPLY ONLY TO THE MG UNITS REGISTERED WITH MG THAT BEARS THE MODEL AND SERIAL NUMBERS STATED ON THE INSTALLATION START UP RECORD, AND MG SHALL NOT, IN ANY EVENT, BE LIABLE UNDER THE TERMS OF THIS LIMITED WARRANTY UNLESS THIS INSTALLATION START UP RECORD HAS BEEN ENDORSED BY OWNER & DEALER/INSTALLER AND RECEIVED BY MG LIMITED WITHIN 90 DAYS OF START UP.

Limitation: This Limited Express Residential Warranty is given in lieu of all other warranties. If, notwithstanding the disclaimers contained herein, it is determined that other warranties exist, any such express warranty, including without limitation any express warranties or any implied warranties of fitness for particular purpose and merchantability, shall be limited to the duration of the Limited Express Residential Warranty.

LIMITATION OF REMEDIES In the event of a breach of the Limited Express Residential Warranty, MG will only be obligated at MG's option to repair the failed part or unit, or to furnish a new or rebuilt part or unit in exchange for the part or unit which has failed. If after written notice to MG's factory in Petitcodiac, New Brunswick of each defect, malfunction or other failure, and a reasonable number of attempts by MG to correct the defect, malfunction or other failure, and the remedy fails of its essential purpose, MG shall refund the purchase price paid to MG in exchange for the return of the sold good(s). Said refund shall be the maximum liability of MG. **THIS REMEDY IS THE SOLE AND EXCLUSIVE REMEDY OF THE BUYER OR PURCHASER AGAINST MG FOR BREACH OF CONTRACT, FOR THE BREACH OF ANY WARRANTY OR FOR MG'S NEGLIGENCE OR IN STRICT LIABILITY.**

LIMITATION OF LIABILITY MG shall have no liability for any damages if MG's performance is delayed for any reason or is prevented to any extent by any event such as, but not limited to: any war, civil unrest, government restrictions or restraints, strikes, or work stoppages, fire, flood, accident, shortages of transportation, fuel, material, or labour, acts of God or any other reason beyond the sole control of MG. **MG EXPRESSLY DISCLAIMS AND EXCLUDES ANY LIABILITY FOR CONSEQUENTIAL OR INCIDENTAL DAMAGE IN CONTRACT, FOR BREACH OF ANY EXPRESS OR IMPLIED WARRANTY, OR IN TORT, WHETHER FOR MG'S NEGLIGENCE OR AS STRICT LIABILITY.**

OBTAINING WARRANTY PERFORMANCE Normally, the dealer or service organization who installed the products will provide warranty performance for the owner. Should the installer be unavailable, contact any MG recognized distributor, dealer or service organization. If assistance is required in obtaining warranty performance, write or call: Maritime Geothermal Ltd • Customer Service • PO Box 2555 • Petitcodiac, New Brunswick E4Z 6H4 • (506) 756-8135 • or e-mail to info@nordicghp.com NOTE: Some states or Canadian provinces do not allow limitations on how long an implied warranty lasts, or the limitation or exclusions of consequential or incidental damages, so the foregoing exclusions and limitations may not apply to you. This warranty gives you specific legal rights, and you may also have other rights which vary from state to state and from Canadian province to Canadian province. Please refer to the MG Installation, Installation and Service Manual for operating and maintenance instructions.

An extended warranty option is also available. Please contact Maritime Geothermal Ltd. via the contact information in the previous paragraph for more information.