



# Sun StorageTek™ Crypto Key Management System

Version 2.0

**Installation and Service Manual**

Part Number: 316194902

Revision: B





# Crypto Key Management System

Version 2.0

---

## Installation and Service Manual

Sun Microsystems, Inc.  
[www.sun.com](http://www.sun.com)

Part Number: 316194902  
May 2008  
Revision: B

Copyright © 2008 Sun Microsystems, Inc., 4150 Network Circle, Santa Clara, California 95054, U.S.A. All rights reserved.

Sun Microsystems, Inc. has intellectual property rights relating to technology embodied in the product that is described in this document. In particular, and without limitation, these intellectual property rights may include one or more of the U.S. patents listed at <http://www.sun.com/patents> and one or more additional patents or pending patent applications in the U.S. and in other countries.

**THIS PRODUCT CONTAINS CONFIDENTIAL INFORMATION AND TRADE SECRETS OF SUN MICROSYSTEMS, INC. USE, DISCLOSURE OR REPRODUCTION IS PROHIBITED WITHOUT THE PRIOR EXPRESS WRITTEN PERMISSION OF SUN MICROSYSTEMS, INC.**

Use is subject to license terms. This distribution may include materials developed by third parties. This distribution may include materials developed by third parties. Parts of the product may be derived from Berkeley BSD systems, licensed from the University of California.

UNIX is a registered trademark in the U.S. and in other countries, exclusively licensed through X/Open Company, Ltd. Sun, Sun Microsystems, the Sun logo, Solaris, Sun StorageTek Crypto Key Management Station, StorageTek and the StorageTek logo are trademarks or registered trademarks of Sun Microsystems, Inc. in the U.S. and other countries.

Products covered by and information contained in this service manual are controlled by U.S. Export Control laws and may be subject to the export or import laws in other countries. Nuclear, missile, chemical biological weapons or nuclear maritime end uses or end users, whether direct or indirect, are strictly prohibited. Export or reexport to countries subject to U.S. embargo or to entities identified on U.S. export exclusion lists, including, but not limited to, the denied persons and specially designated nationals lists is strictly prohibited. Use of any spare or replacement CPUs is limited to repair or one-for-one replacement of CPUs in products exported in compliance with U.S. export laws. Use of CPUs as product upgrades unless authorized by the U.S. Government is strictly prohibited.

**DOCUMENTATION IS PROVIDED "AS IS" AND ALL EXPRESS OR IMPLIED CONDITIONS, REPRESENTATIONS AND WARRANTIES, INCLUDING ANY IMPLIED WARRANTY OF MERCHANTABILITY, FITNESS FOR A PARTICULAR PURPOSE OR NON-INFRINGEMENT, ARE DISCLAIMED, EXCEPT TO THE EXTENT THAT SUCH DISCLAIMERS ARE HELD TO BE LEGALLY INVALID.**

Copyright © 2008 Sun Microsystems, Inc., 4150 Network Circle, Santa Clara, California 95054, Etats-Unis. Tous droits réservés.

Sun Microsystems, Inc. détient les droits de propriété intellectuels relatifs à la technologie incorporée dans le produit qui est décrit dans ce document.

En particulier, et ce sans limitation, ces droits de propriété intellectuelle peuvent inclure un ou plus des brevets américains listés à l'adresse <http://www.sun.com/patents> et un ou les brevets supplémentaires ou les applications de brevet en attente aux Etats - Unis et dans les autres pays.

**CE PRODUIT CONTIENT DES INFORMATIONS CONFIDENTIELLES ET DES SECRETS COMMERCIAUX DE SUN MICROSYSTEMS, INC. SON UTILISATION, SA DIVULGATION ET SA REPRODUCTION SONT INTERDITES SANS L'AUTORISATION EXPRESSE, ECRITE ET PREALABLE DE SUN MICROSYSTEMS, INC.**

L'utilisation est soumise aux termes de la Licence. Cette distribution peut comprendre des composants développés par des tierces parties. Cette distribution peut comprendre des composants développés par des tierces parties. Des parties de ce produit pourront être dérivées des systèmes Berkeley BSD licenciés par l'Université de Californie.

UNIX est une marque déposée aux Etats-Unis et dans d'autres pays et licenciée exclusivement par X/Open Company, Ltd. Sun, Sun Microsystems, le logo Sun, Solaris, Sun StorageTek Crypto Key Management Station, StorageTek et le logo StorageTek sont des marques de fabrique ou des marques déposées de Sun Microsystems, Inc. aux Etats-Unis et dans d'autres pays.

Ce produit est soumis à la législation américaine en matière de contrôle des exportations et peut être soumis à la réglementation en vigueur dans d'autres pays dans le domaine des exportations et importations. Les utilisations, ou utilisateurs finaux, pour des armes nucléaires, des missiles, des armes biologiques et chimiques ou du nucléaire maritime, directement ou indirectement, sont strictement interdites. Les exportations ou reexportations vers les pays sous embargo américain, ou vers des entités figurant sur les listes d'exclusion d'exportation américaines, y compris, mais de manière non exhaustive, la liste de personnes qui font objet d'un ordre de ne pas participer, d'une façon directe ou indirecte, aux exportations des produits ou des services qui sont régis par la législation américaine en matière de contrôle des exportations et la liste de ressortissants spécifiquement désignés, sont rigoureusement interdites. L'utilisation de pièces détachées ou d'unités centrales de remplacement est limitée aux réparations ou à l'échange standard d'unités centrales pour les produits exportés, conformément à la législation américaine en matière d'exportation. Sauf autorisation par les autorités des Etats-Unis, l'utilisation d'unités centrales pour procéder à des mises à jour de produits est rigoureusement interdite.

**LA DOCUMENTATION EST FOURNIE "EN L'ETAT" ET TOUTES AUTRES CONDITIONS, DECLARATIONS ET GARANTIES EXPRESSES OU TACITES SONT FORMELLEMENT EXCLUES, DANS LA MESURE AUTORISEE PAR LA LOI APPLICABLE, Y COMPRIS NOTAMMENT TOUTE GARANTIE IMPLICITE RELATIVE A LA QUALITE MARCHANDE, A L'APTITUDE A UNE UTILISATION PARTICULIERE OU A L'ABSENCE DE CONTREFACON.**

We welcome your feedback. Use the OpinionLab [+] feedback system on the documentation Web site or Send your comments to:

Sun Learning Services  
Sun Microsystems, Inc.  
500 Eldorado Blvd.  
Mailstop: UBRM06-307  
Broomfield, CO 80021-6307  
USA

Please include the publication name, part number, and edition number in your correspondence if they are available. This will expedite our response.



Please  
Recycle



Adobe PostScript

# Summary of Changes

---

EC Number	Date	Revision	Description
EC000227	February 2008	A	Initial release.
EC000496	May 2008	B	This revision includes: <ul style="list-style-type: none"><li>■ New documentation feedback system</li><li>■ <a href="#">Additional Information on page xvi</a></li><li>■ <a href="#">Obtain the Drive Data on page 36</a></li><li>■ Support for the T9840D tape drive (throughout)</li><li>■ Reader's comments</li></ul>

**Note** – Change bars are included in this revision.



# Contents

---

**Summary of Changes** iii

**Contents** v

**Figures** ix

**Tables** xi

**Preface** xiii

Organization xiii

Related Information xiv

Documentation Map xv

Documentation Content and Purpose xv

Additional Information xvi

Sun's External Web Site xvi

Documentation and Download Web Sites xvi

Partners Site xvi

## **1. Introduction** 1

Planning 1

Administrator Guide 1

Before Beginning 2

Required Tools 2

Unpack and Inventory the Contents 2

## **2. Key Management Appliances** 3

Overview 3

Front and Rear Views 5

Specifications 6

Installation	7
Configure the ELOM IP Address	8
Start the embedded Lights Out Manager	9
Alternate Method	10
Using a Network Connection	10
QuickStart Program	13
Tips and Notes	14
QuickStart Wizard	15
Configuration Checklist	21
Change the ELOM Password	27
Add KMAs to the Cluster	28
Run the QuickStart Wizard	29
<b>3. Tape Drives</b>	<b>31</b>
Before Beginning	32
Required Tools	32
Tape Drive LEDs	33
Service Representative Work Sheet	34
Customer Work Sheet	35
Obtain the Drive Data	36
Create a Drive Data File Structure	38
License and Enroll the Tape Drives	39
License the Tape Drives	39
Enroll the Tape Drives	41
<b>4. Encryption Hardware Kits</b>	<b>45</b>
SL8500 Library	46
SL8500 Accessory Racks	48
Encryption Hardware	49
Drive Tray	49
External Rack Installations	50
SL3000 Library	51
SL500 Library	52
9310 Library and 9741e Drive Cabinet	53
External Rack Installation	53



Drive Cabinet Ethernet Switch	54
Cable Routing	55
L-Series Libraries	56
L-Series Library Rack Space	56
L700/L1400 Library Encryption Hardware	57
L180 Library Encryption Hardware	58
Rackmount	59
Service Delivery Platform	60
<b>5. Service</b>	<b>61</b>
Field Replaceable Units	62
Account Log	63
Obtaining Support	64
Replacing or Adding a New KMA	65
System Upgrade	67
Restore From Backup	68
System Dump	69
Tape Drives	70
Switch Encryption On and Off	71
KMS Version 1.x Support	72
<b>A. Work Sheets</b>	<b>73</b>
Obtaining Support	74
Initial Configuration Work Sheet	75
User Roles Work Sheet	76
Tape Drives Work Sheet	77
Drive Enrollment Work Sheet	78
<b>B. Migration Instructions</b>	<b>81</b>
Prerequisites	81
Basic Steps	82
Description	82
Stage 1	82
Stage 2	82
Stage 3	82
Instructions	83



# Figures

---

FIGURE 2-1	Key Management Appliance—Front Panel	5
FIGURE 2-2	Key Management Appliance—Rear Panel	5
FIGURE 2-3	embedded Lights Out Manager Login Screen	10
FIGURE 2-4	Power Control	11
FIGURE 2-5	Power Control	12
FIGURE 2-6	ELOM Password Reset	27
FIGURE 2-7	KMA Replacement—Joining a Existing Cluster	29
FIGURE 2-8	KMA Replacement—Joining a Existing Cluster	29
FIGURE 3-1	Tape Drive Serial Number—VOP	36
FIGURE 3-2	Request an Encryption Key Application	36
FIGURE 3-3	Encryption File Request for Drive Data	37
FIGURE 3-4	Encryption File Request for Drive Data	37
FIGURE 3-5	Drive Data File Structure	38
FIGURE 4-1	SL8500 Accessory Rack Guidelines	46
FIGURE 4-2	SL8500 Capabilities with Encryption	47
FIGURE 4-3	T10000 Drive Tray	49
FIGURE 4-4	External Rack Installation	50
FIGURE 4-5	SL3000 Library	51
FIGURE 4-6	SL500 Library	52
FIGURE 4-7	9310–PowderHorn–Library	53
FIGURE 4-8	Drive Cabinet Ethernet Switch Installation	54
FIGURE 4-9	External Rack and Ethernet Cabling	55
FIGURE 4-10	L-Series Libraries	56
FIGURE 4-11	L-Series Libraries	57

FIGURE 4-12	L-Series Libraries	58
FIGURE 4-13	Rackmount Assembly	59
FIGURE 4-14	Rackmount Instructions	59
FIGURE 4-15	Systems Delivery Platform	60
FIGURE 5-1	KMA Replacement—Joining a Existing Cluster	65
FIGURE 5-2	KMA Replacement—Joining a Existing Cluster	66
FIGURE 5-3	System Upgrade	67
FIGURE 5-4	Restore Backup	68
FIGURE 5-5	System Dump	69
FIGURE 5-6	Switch Encryption On and Off	71
FIGURE 5-7	Switch Encryption On and Off	72
FIGURE B-1	Import Keys	83

# Tables

---

TABLE P-1	Documentation and Audience Map	xv
TABLE P-2	Documentation Content and Purpose	xv
TABLE 2-1	Initial Configuration Settings	4
TABLE 2-2	Sun Fire X2100 Specifications	6
TABLE 2-3	KMA LAN Connections	8
TABLE 2-4	Compatible Web Browser and Java Versions	9
TABLE 2-5	Initial Configuration Checklist	21
TABLE 3-1	Tape Drive Support	31
TABLE 3-2	Tape Drive Encryption LED	33
TABLE 3-3	Drive Data Work Sheet	34
TABLE 3-4	Enrollment Data Work Sheet	35
TABLE 4-1	SL8500 Accessory Rack Guidelines	48
TABLE 4-2	SL3000 Module Types	51
TABLE 5-1	FRU Listing	62
TABLE 5-2	Keyboard Monitor Kit	62
TABLE 5-3	KMA Account Log	63
TABLE 5-4	Obtaining Support	64
TABLE 0-1	Obtaining Support	74
TABLE A-1	Initial Configuration Settings—Customer	75
TABLE A-2	User Roles Work Sheet—Customer	76
TABLE A-3	Tape Drive Work Sheet—Service Representative	77
TABLE A-4	Enrollment Data Work Sheet—Customer	78



# Preface

---

This installation and service manual is intended for Sun StorageTek™ service representatives, qualified partners, representatives, and customers doing the installation and initial configuration of the Crypto Key Management System Version 2.0.

The installation is a Multi-Step process that requires **collaboration** between the installers and the customer to complete.

---

## Organization

This guide has the following organization:

Chapter	Use this chapter to:
<a href="#">Chapter 1, "Introduction"</a>	Prepare for the installation
<a href="#">Chapter 2, "Key Management Appliances"</a>	Install the Crypto Key Management Appliance (KMA)—a Sun Fire X2100M2 server.
<a href="#">Chapter 3, "Tape Drives"</a>	<ul style="list-style-type: none"><li>■ Create Agent IDs and passphrases</li><li>■ Obtain the Drive Data—PC Key</li><li>■ License the Tape Drives</li><li>■ Enroll the Tape Drives</li></ul>
<a href="#">Chapter 4, "Encryption Hardware Kits"</a>	Install the additional encryption hardware in supported configurations.
<a href="#">Chapter 5, "Service"</a>	This chapter contains procedures to help maintain the Key Management System Version 2.0.
<a href="#">Appendix A, "Work Sheets"</a>	Help prepare for the installation by completing the work sheets.
<a href="#">Appendix B, "Migration Instructions"</a>	Migrate keys: <ul style="list-style-type: none"><li>■ From a Version 1.x KMS</li><li>■ To a Version 2.0 KMA</li></ul>

## Related Information

These publications contain the additional information mentioned in this guide:

Publication Description	Part Number
Important Safety Information for Sun Hardware Systems	Sun: 816-7190-10
<i>Sun SunFire X2100 Server Installation Guide</i>	Sun: 819-6589-10

These publications are for Sun StorageTek personnel or authorized third parties who install StorageTek brand tape and library products.

Publication Description	Part Number
T10000 Tape Drive Installation Manual	StorageTek: 96173
T10000 Service Manual	StorageTek: 96175
Virtual Operator Panel—Service	StorageTek: 96180
Virtual Operator Panel—Customer	StorageTek: 96179
T9x40 Tape Drive Installation Manual	StorageTek: 95879
T9x40 Service Manual	StorageTek: 95740
SL8500 Modular Library System Installation Manual	StorageTek: 96138
SL3000 Modular Library System Installation Manual	StorageTek: 316194201
SL500 Modular Library System Installation Manual	StorageTek: 96114
L700/1400 Library Installation Manual	StorageTek: 95843
L180 Library Installation Manual	StorageTek: 95896
9310 PowderHorn Library Installation Manual	StorageTek: 9314

These publications are related to the key management system:

Publication Description	Part Number
Crypto Key Management System Administrator Guide	StorageTek: 316195101

When planning to support data encryption, the following documents are available to help identify and define encryption:

- Federal Information Processing Standards Publication FIPS PUB 46-3  
*Data Encryption Standard*
- Federal Information Processing Standards Publication FIPS PUB 140-2  
*Security Requirements for Cryptographic Modules*
- Federal Information Processing Standards Publication FIPS PUB 171  
*Key Management*
- National Institute of Standards and Technology NIST Publication 800-57  
*Recommendation for Key Management Parts 1 and 2*
- International Standard Organization ISO/IEC 1779  
*Security Techniques—Code of Practice for Information Security Management*



## Documentation Map

This table shows the specific documents for the Crypto Key Management System and the audience that document is intended for.

**TABLE P-1** Documentation and Audience Map

Task/Purpose	Documentation & Audience								
	AE	SE	PS	TS	T3	SR	Partner/OEM	Customer	
Site Preparation/Pre-sales	Systems Assurance Guide								
Installation & Service	Installation & Service Manual								
User / Operation	Administrator Guide								
Online Help	Online Help								
<b>Legend:</b> AE = Account executive, sales and marketing SE = Systems engineer PS = Professional services				TS = Technical specialists (NSSE) T3 = Support (Frontline and Backline) SR = Service representative (CSE)					

## Documentation Content and Purpose

This table contains an overview of the Crypto Key Management System documentation, intended audience, general content, and purpose.

**TABLE P-2** Documentation Content and Purpose

Document	Audience	General Content	Purpose
Systems Assurance Guide (PN 316194801)	<ul style="list-style-type: none"> <li>■ Marketing &amp; Sales</li> <li>■ Systems Engineers</li> <li>■ Installation Coordinators</li> <li>■ Professional Services</li> <li>■ Technical Specialists</li> <li>■ Service Representatives</li> <li>■ Customer</li> </ul>	<ul style="list-style-type: none"> <li>■ Product description</li> <li>■ Dimensions</li> <li>■ Weights &amp; measures</li> <li>■ Configurations</li> <li>■ Capacities</li> <li>■ Site preparation</li> <li>■ Models and features</li> <li>■ Order numbers</li> </ul>	<ul style="list-style-type: none"> <li>■ Pre-Sales</li> <li>■ Site Planning</li> <li>■ Product introduction</li> <li>■ Readiness</li> </ul>
Installation and Service Manual (PN 316194901)	<ul style="list-style-type: none"> <li>■ Installation Coordinators</li> <li>■ Technical Specialists</li> <li>■ Service Representatives</li> </ul>	Installation: <ul style="list-style-type: none"> <li>■ Procedures</li> <li>■ Checklists</li> <li>■ Configurations</li> </ul> Service: <ul style="list-style-type: none"> <li>■ Fault isolation</li> <li>■ Removal/Replacement</li> </ul>	<ul style="list-style-type: none"> <li>■ Installation</li> <li>■ Configuration</li> <li>■ embedded Lights Out Manager (ELOM)</li> <li>■ QuickStart</li> </ul>
Administrator Guide (PN 316195101)	<ul style="list-style-type: none"> <li>■ Customer</li> <li>■ Technical Specialists</li> <li>■ Service Representatives</li> </ul>	<ul style="list-style-type: none"> <li>■ Introduction</li> <li>■ Operator Roles</li> <li>■ How to...</li> </ul>	<ul style="list-style-type: none"> <li>■ Usage</li> <li>■ Support</li> <li>■ KMS Manager / GUI</li> </ul>
Online Help	<ul style="list-style-type: none"> <li>■ Customer</li> <li>■ Technical Specialists</li> <li>■ Service Representatives</li> </ul>	<ul style="list-style-type: none"> <li>■ Online help</li> </ul>	<ul style="list-style-type: none"> <li>■ Usage</li> <li>■ Support</li> <li>■ KMS Manager / GUI</li> </ul>

## Additional Information

Sun Microsystems, Inc. (Sun) offers several methods to obtain additional information.

### Sun's External Web Site

Sun's external Web site provides marketing, product, event, corporate, and service information. The external Web site is accessible to anyone with a Web browser and an Internet connection.

The URL for the external Web site is: <http://www.sun.com>

The URL for StorageTek™ brand-specific information is:  
<http://www.sun.com/storagetek/>

### Documentation and Download Web Sites

Web sites that enable customers, members, and employees to search for technical documentation, downloads, patches, features, and articles include:

- Documentation: <http://docs.sun.com/app/docs> (customers)
- Internal access: <http://docs.sfbay.sun.com/app/docs> (internal)
- Sun Download Center: <http://www.sun.com/download/index.jsp> (customers)
- Sun Partner Exchange: <https://spe.sun.com/spx/control/Login> (partners)
- Uniform Software Repository: <http://dlrequest.sfbay.sun.com:88/usr/login> (internal)

If your customer does not already have a Sun Online Account they will need to register. For a new account, go to: <https://reg.sun.com/register>

For more information about Sun StorageTek products, got to:  
[http://sunsolve.sun.com/handbook\\_pub/validateUser.do?target=STK/STK\\_index](http://sunsolve.sun.com/handbook_pub/validateUser.do?target=STK/STK_index)

### Partners Site

The Sun StorageTek Partners site is a Web site for partners with a StorageTek Partner Agreement. This site provides information about products, services, customer support, upcoming events, training programs, and sales tools to support StorageTek Partners. Access to this site, beyond the Partners Login page, is restricted. On the Partners Login page, employees and current partners who do not have access can request a login ID and password and prospective partners can apply to become StorageTek resellers.

The URL for partners with a Sun Partner Agreement is:  
<http://www.sun.com/partners/>

## Introduction

---

Encryption is based on the science of **cryptography** and is one of the most effective ways to achieve data security. To read an encrypted file, you must have access to the key that will enable you to decipher the file.

---

## Planning

Planning and the use of the *Systems Assurance Guide* should have occurred before any equipment arrives on site.

The system assurance process is the exchange of information among team members to ensure that no aspects of the sale, order, **installation** and implementation are overlooked. Information from this guide includes:

- Installation planning checklist
- Conceptual drawings
- Site preparation checklist
- Work Sheets

This information can help promote an error-free installation and contribute to the overall customer satisfaction.

---

## Administrator Guide



Make sure you download and give the customer copies of the *Crypto Key Management System Administrator Guide* PN: 316195101.

The customer requires this guide to complete the configuration, assign roles, and perform daily tasks and functions.

This guide and all KMS Version 2.0 documentation can be downloaded from:  
[docs.sun.com](http://docs.sun.com)

## Before Beginning

Before beginning, survey the installation site and make sure there is:

- Sufficient space to install and maintain the servers.
- Trained representatives to install the equipment. More than one person might be required to install equipment into the rack or to remove equipment from the rack.
- Consider the total weight when you place equipment into the rack. To prevent an unbalanced situation:
  - Load equipment in a rack from the bottom to the top.
  - Install the heaviest equipment on the bottom and the lightest on the top.
  - Install an anti-tilt bar to provide additional stability.

Failure to do so might cause an unstable condition.

- Adequate cooling for the servers.

Ensure that the temperature in the rack does not exceed the maximum ambient rated temperatures for all of the equipment installed in the rack.

Ensure that there is adequate cooling to support all of the equipment in the rack.

- Proper power connections and ground.
  - If installing the servers to support *power redundancy*, make sure there are two separate branch circuits available. Should a power supply or circuit fail, the other server can continue operations until the problem is fixed.
  - If removing power from the servers, the other rack equipment is not affected.

## Required Tools

The required tools to install and initially configure the server are:

- Standard field service tool kit, including both standard and Phillips screwdrivers, Torx driver and bits, and side cutters; tools necessary to mount the servers in a rack.
- Serial or null modem cable (PN: 24100134) with DB-9 connector
- Adapter (PN: 10402019)
- Straight Ethernet cable (PN: 24100216) 10-ft
- Cross-over Ethernet cable (PN: 24100163) 10-ft
- Service laptop (or personal computer)
- Virtual Operator Panel, Version 1.0.11 or higher (service and customer versions)

## Unpack and Inventory the Contents

To begin the installation, unpack and inventory the contents, which includes:

- Sun Fire X2100 server
- Server accessory kit
- Rack mount kits
- Power cables
- Tape drives
- Additional encryption hardware kits

Make sure there is no physical damage or loose parts.

# Key Management Appliances

---

This chapter describes how to install and initially configure the Crypto Key Management Appliance (KMA)—a Sun Fire X2100M2 server.

---

## Overview

The initial setup of a KMA uses a console connection that can be done using a:

- Monitor and keyboard directly connected to the KMA or
- Laptop with the embedded Lights Out Manager (ELOM)

The ELOM remote console function requires a network connection, labeled “ELOM Network” in the diagram [on page 5](#).

The ELOM's IP address must be configured as described later in this document in order to use the remote console function.



Servers *must be* installed in pairs called a cluster. Clusters perform backups of each appliance; therefore, no external hard drives are required.

Each key management appliance has the capability of three network connections that may be used—only one connection is required (LAN 0). These connections are:

- LAN 0 = Management network
- LAN 1 = embedded Lights Out Manager (ELOM) network
- LAN 2 = Service network

Each of these connections (if made) requires an IP address / hostname.

[TABLE 2-1 on page 4](#) provides space to record these connections and initial customer settings. This information is necessary to:

- “[Configure the ELOM IP Address](#)” [on page 8](#)
- Run “[QuickStart Program](#)” [on page 13](#)

**Note** – The customer does not need to record the actual passphrases; this just serves as a reminder of the upcoming requirements.

**TABLE 2-1** Initial Configuration Settings  
 TABLE 2-1 provides space to record information for use with the “QuickStart Program” on page 13.

	First KMA			Second KMA		
	Hostname	IP Address / Netmask	DHCP?¹	Hostname	IP Address / Netmask	DHCP?¹
LAN 0 = Management			Yes <input type="checkbox"/> No <input type="checkbox"/>			Yes <input type="checkbox"/> No <input type="checkbox"/>
LAN 1 = ELOM			Yes <input type="checkbox"/> No <input type="checkbox"/>			Yes <input type="checkbox"/> No <input type="checkbox"/>
LAN 2 = Service			Yes <input type="checkbox"/> No <input type="checkbox"/>			Yes <input type="checkbox"/> No <input type="checkbox"/>
LAN 3 = Reserved						
KMA Name						
Gateway						
DNS Server	Hostname: IP address:			Hostname: IP address:		
Security Officer	Login: Passphrase:			Login: Passphrase:		
Root account Passphrase	Login: Passphrase:			Login: Passphrase:		
ELOM Passphrase	Login: Passphrase:			Login: Passphrase:		
Key Split Credentials						
Autonomous Unlocking ²						
Keyboard Type See the list on page 15						
<p><b>Note:</b></p> <ol style="list-style-type: none"> <li>Addresses assigned using DHCP <b>must be static</b>. The system cannot handle the DHCP server changing the IP addresses once assigned.</li> <li>Autonomous Unlocking allows the KMA to enter a fully operational state after a hard or soft reset without requiring the entry of a quorum of passphrases using the KMS Manager. This information should not be written down and should be entered by the person to which they belong. These entries can be changed in the KMS Manager; so it may be desirable to enter something simple during the configuration, then change it later using the KMS GUI immediately after the KMA is configured.</li> </ol>						

# Front and Rear Views

- FIGURE 2-1 is an example for the front of the appliance
  - FIGURE 2-2 is an example for the rear of the appliance
- Note: The rear of the appliance is where all of the cable connections are made.

FIGURE 2-1 Key Management Appliance—Front Panel

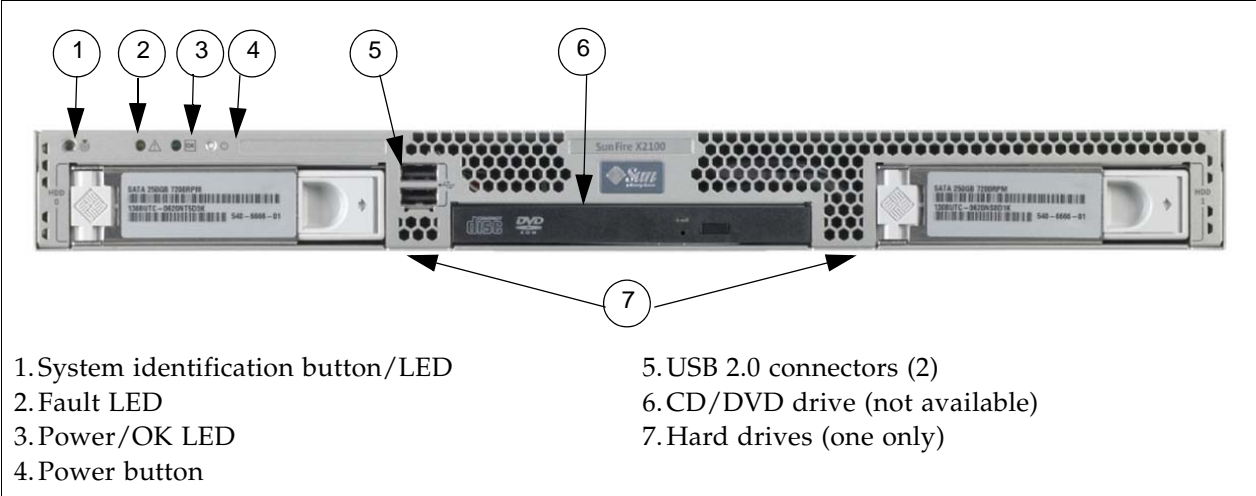
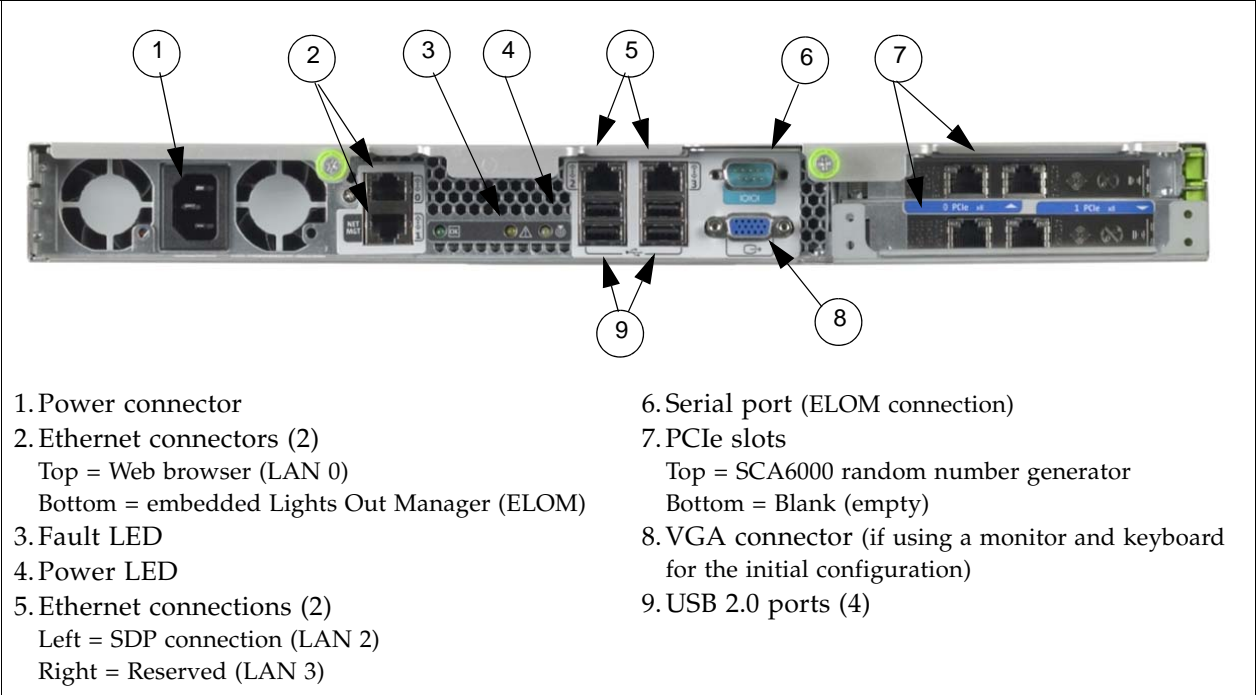

FIGURE 2-2 Key Management Appliance—Rear Panel



**Note** – The ELOM IP address is most easily configured using a serial connection (callout #6) by connecting a DB9-to-DB9 serial null modem cable from a PC serial port to the serial port on the server.

This is a **one time** connection and **one time** configuration requirement.

## Specifications

[TABLE 2-2](#) lists the specifications for the SunFire X2100 server.

**TABLE 2-2** Sun Fire X2100 Specifications

<b>Processor</b>	<ul style="list-style-type: none"> <li>■ One dual-core AMD Operton processor</li> <li>■ Processor frequencies: 2.2 GHz</li> <li>■ Up to 1 MB level 2 cache</li> </ul>
<b>Memory</b>	<ul style="list-style-type: none"> <li>■ Four DIMM slots (up to 4 gigabytes)</li> <li>■ Unbuffered ECC memory</li> </ul>
<b>IPMI 2.0</b>	<ul style="list-style-type: none"> <li>■ Service processor standard</li> <li>■ embedded Lights Out Manager</li> </ul>
<b>Mass storage</b>	One SATA disk drive
<b>PCI Slots</b>	Two PCI-Express slots (PCIe) PCIe-0 contains the Sun Crypto Accelerator 6000 (SCA6000)
<b>Networking</b>	<ul style="list-style-type: none"> <li>■ Four USB 2.0 connectors on the rear panel</li> <li>■ Two USB 2.0 connectors on the front panel</li> <li>■ Two ports: Serial port with DB-9; VGA with DB-15 connectors</li> <li>■ Four 10/100/1000 Base-T Ethernet ports</li> </ul>
<b>Dimensions:</b>	
Height	43 mm (1.7 in.)
Width	425.5mm (16.8 in.)
Depth	633.7 mm (25 in.)
Weight (maximum)	10.7 kg (23.45 lb)
Mounting options	19-inch rackmount kit; Compact 1 rack-unit (1.75 in.) form factor
<b>Environmental parameters:</b>	
Temperature	5°C to 35°C (41°F to 95°F)
Relative humidity	27°C (80°F) max wet bulb
Altitude	Up to 3,000 m (9,000 ft)
Power supply	One 6.5 Amps at 345 Watts Heat output is about 850 BTU/hour
<b>Regulations meets or exceeds the following requirements:</b>	
Acoustic Noise Emissions declared in accordance with ISO 9296	
Safety IEC 60950, UL/CSA60950, EN60950, CB scheme	
RFI/EMI FCC Class A, Part 15 47 CFR, EN55022, CISPR 22, EN300-386:v1.31, ICES-003	
Immunity: EN55024, EN300-386:v1.3.2	
Certifications: Safety CE Mark, GOST, GS Mark, cULus Mark, CB scheme, CCC, S Mark	
EMC CE Mark, Emissions and Immunity Class A Emissions Levels: FCC, C-Tick, MIC, CCC, GOST, BSMI, ESTI, DOC, S Mark	



---

# Installation

Install the servers in a standard 483-mm (19-in.) rack. The rack contains units of measurement called rack units (Us) that equal 44.5 mm (1.75 in.). Become familiar with the rack and look to see how the rack units patterns are separated.

The top cover of the server contains instructions to install the servers in a four post rack or cabinet—two-post racks are *not* compatible.

The slide rails are compatible with a wide range of racks, meets the following standards, and requires:

- Horizontal opening and unit vertical pitch conforming to ANSI/EIA 310-D-1992 or IEC 60927 standards.
- Distance between front and rear mounting planes between 610 mm and 915 mm (24 in. to 36 in.)
- Clearance depth to a front cabinet door must be at least 25.4 mm (1 in.)
- Clearance depth to a rear cabinet door at least 800 mm (31.5 in.) to incorporate cable management or 700 mm (27.5 in.) without cable management.
- Clearance width between structural supports and cable troughs and between front and rear mounting planes is at least 456 mm (18 in.)

Refer to the *Sun Fire X2100 Server Installation Guide* for additional information. This guide is included with the server accessory kit.

1. Install both servers in the rack.

## Configure the ELOM IP Address

To initially configure the ELOM IP address for LAN 1:

- Using [TABLE 2-1](#) and [FIGURE 2-2](#), connect all cables *as required*.

**Note – Wait until instructed to connect the power cable.**

**TABLE 2-3** KMA LAN Connections

LAN 0	<p>Callout 2, top connector is <i>required</i>.</p> <p>This network is called the “<b>management network</b>” and connects to the Key Management System (KMS), graphical user interface (GUI), and is used for encryption key management.</p> <p>This connection is also used to replicate information between KMAs in a KMS Cluster. All KMAs in a KMS Cluster must be connected to each other’s LAN 0 interface.</p> <p>The gateway supplied during the QuickStart program should be reachable using the LAN 0 connection.</p> <p>Tape drives may also be connected on the LAN 0 management network, but may also be connected to the LAN 2 service network.</p>
LAN 1	<p>Callout 2, bottom connector is <i>optional</i>.</p> <p>This connection is called the “<b>NET MGT ELOM</b>” and provides a network connection for the embedded Lights Out Manager.</p>
LAN 2	<p>Callout 6 left connector is <i>optional</i>.</p> <p>This network is called the “<b>service network</b>” and the connection goes to the Service Delivery Platform—SDP—if <i>installed</i>.</p> <p>Tape drives normally connect to this network, which is supplied by Ethernet switches in accessory kits purchased with the KMAs.</p>
LAN 3	<p>Callout 6 right connector is <i>reserved</i> and requires no connection.</p>

- Connect a null modem, serial cable to the DB-9 connector (callout 7).  
Connect the other end to a laptop (PC) serial port.  
  
A connection to the LAN 1 NET MGT interface is required to initially configure the servers using the QuickStart program.
- Start a HyperTerminal session on the laptop.
- Verify the default settings are:
  - 8-bits, No Parity, and 1 stop-bit
  - 9600 baud rate
  - Disable both hardware (CTS/RTS) and software (XON/XOFF) flow control
- Connect the server to the power source ([FIGURE 2-2](#) callout 1).  
**Do not power-on the server.**  
  
The ELOM starts as soon as power is connected, even if the server is powered-off. The boot process can be observed if connected with the HyperTerminal session. Once the boot completes, the ELOM login prompt will be displayed.
  - a. Press [Enter] a few times to get the ELOM login prompt.
  - b. Log in using:
    - Userid = root
    - Password = changeme

6. Using [TABLE 2-1 on page 4](#) as a reference, configure the ELOM IP address:

**Note** – These commands are case sensitive.

Enter:

```
set /SP/AgentInfo DhcpConfigured=disable
set /SP/AgentInfo IpAddress=ipaddress
set /SP/AgentInfo NetMask=netmask
set /SP/AgentInfo Gateway=gateway
reset
```

An informational command you can use is:	<code>show /SP/SystemInfo/CtrlInfo</code>
--	---

7. Log off of the ELOM and exit.

- If you are going to use the network connection (LAN 1 NET MGT ELOM), disconnect and remove the serial cable (*recommended*).
- The alternative to using the network connection to the ELOM is to use a keyboard and monitor connected to a USB port (keyboard) and the VGA port (monitor.)  
Note: The serial connection to the ELOM cannot be used for the QuickStart program.

**Note** – The ELOM is sensitive to Web browser and Java versions.  
The following is a list of supported versions.

**TABLE 2-4** Compatible Web Browser and Java Versions

Client OS	Java Runtime Environment Including Java Web Start	Web Browsers
<ul style="list-style-type: none"> <li>■ Microsoft Windows XP</li> <li>■ Microsoft Windows 2003</li> <li>■ Microsoft Windows Vista</li> </ul>	JRE 1.5 (Java 5.0 Update 7 or later)	<ul style="list-style-type: none"> <li>■ Internet Explorer 6.0 and later</li> <li>■ Mozilla 1.7.5 or later</li> <li>■ Mozilla Firefox 1.0</li> </ul>
<ul style="list-style-type: none"> <li>■ Red Hat Linux 3.0 and 4.0</li> </ul>		<ul style="list-style-type: none"> <li>■ Mozilla 1.7.5 or later</li> <li>■ Mozilla Firefox 1.0</li> </ul>
<ul style="list-style-type: none"> <li>■ Solaris 9</li> <li>■ Solaris 10</li> <li>■ Solaris Sparc</li> <li>■ SUSE Linux 9.2</li> </ul>		<ul style="list-style-type: none"> <li>■ Mozilla 1.7.5</li> </ul>

You can download the Java 1.5 runtime environment at: <http://java.com>

The current version of the ELOM guide is located at: <http://dlc.sun.com/>

## Start the embedded Lights Out Manager

The embedded Lights Out Manager (ELOM) contains a separate processor from the main server. As soon as power is applied (plugged-in), and after a one or two minute boot period, ELOM provides a remote connection to the console allowing you to perform server functions, such as the *QuickStart* program.

**Note** – This manual has some basic ELOM commands to configure the server. Refer to the *embedded Lights Out Manager Administration Guide* for more information.

Connect to the KMA through the embedded Lights Out Manager using either:

- Network connection—LAN 1 NET MGT ELOM interface—(suggested) or
- Keyboard and monitor attached to the KMAs—(alternate method)



**Popup blockers** will prevent windows from launching in the following procedures. Disable the popup blockers before beginning.

If the window appears, but a console window does not, the Web browser or Java version is incompatible with the ELOM. Upgrade to the latest versions of the browser and Java. See [TABLE 2-4 on page 9](#) for a list of compatible versions.

## Alternate Method

Using [FIGURE 2-2 on page 5](#) as a reference, the alternate method to using the network connection is to use a monitor (connected to the VGA connector callout 8) and keyboard (connected to one of the USB ports in callout 9).

An accessory kit is available: XCRYPTO-KEYBD-MONZ Monitor/Keyboard and rack mount accessory kit, or part number 315496601.

Then follow the same procedure as the network connection.

## Using a Network Connection

1. Using another workstation on the network, launch a Web browser.
2. Connect to the KMA ELOM using the IP Address or hostname of LAN 1 (NET MGT)—the address just configured.

Note: Because the certificate in the ELOM will not match the assigned name or IP, you will receive one or more warnings from your web browser.

3. Click OK or Yes to bypass these warnings.

Once past the warnings, you will receive the ELOM login prompt.

**FIGURE 2-3** embedded Lights Out Manager Login Screen

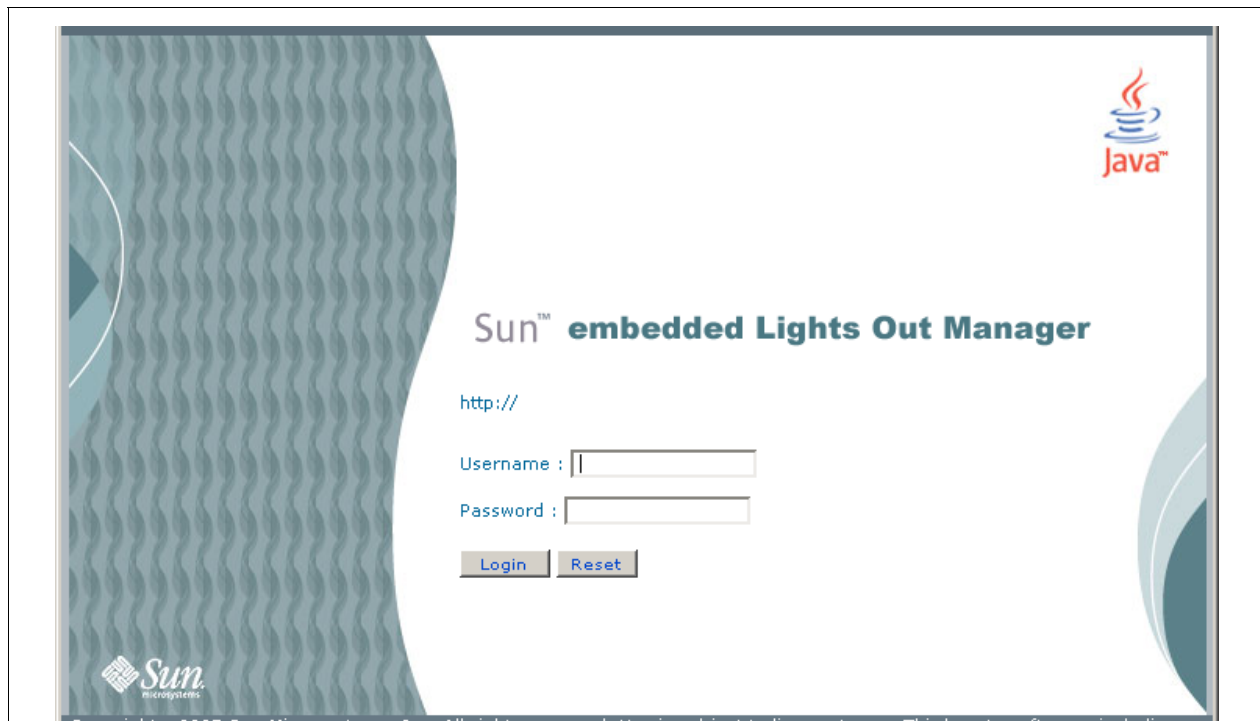

4. Log in using:  
    Userid = root  
    Password = changeme  
  
The next screen is the Manager Screen. If the server has just been connected to power, and it has not been powered on, it will not have completed a system boot.
5. Check the power status by clicking on the “System Monitoring” tab.  
The power status is shown in the table.
6. If the Power Status shows “power off,”  
Click on the “Remote Control” tab to the far right of the upper row of tabs.
7. Click on the “Remote Power Control” tab in the second row of tabs.
8. In the “Select Action” drop-down choose “Power On” and click the “Save” button.  
The KMA will begin powering up. This will take a few minutes; however, you can continue with the KMA configuration.

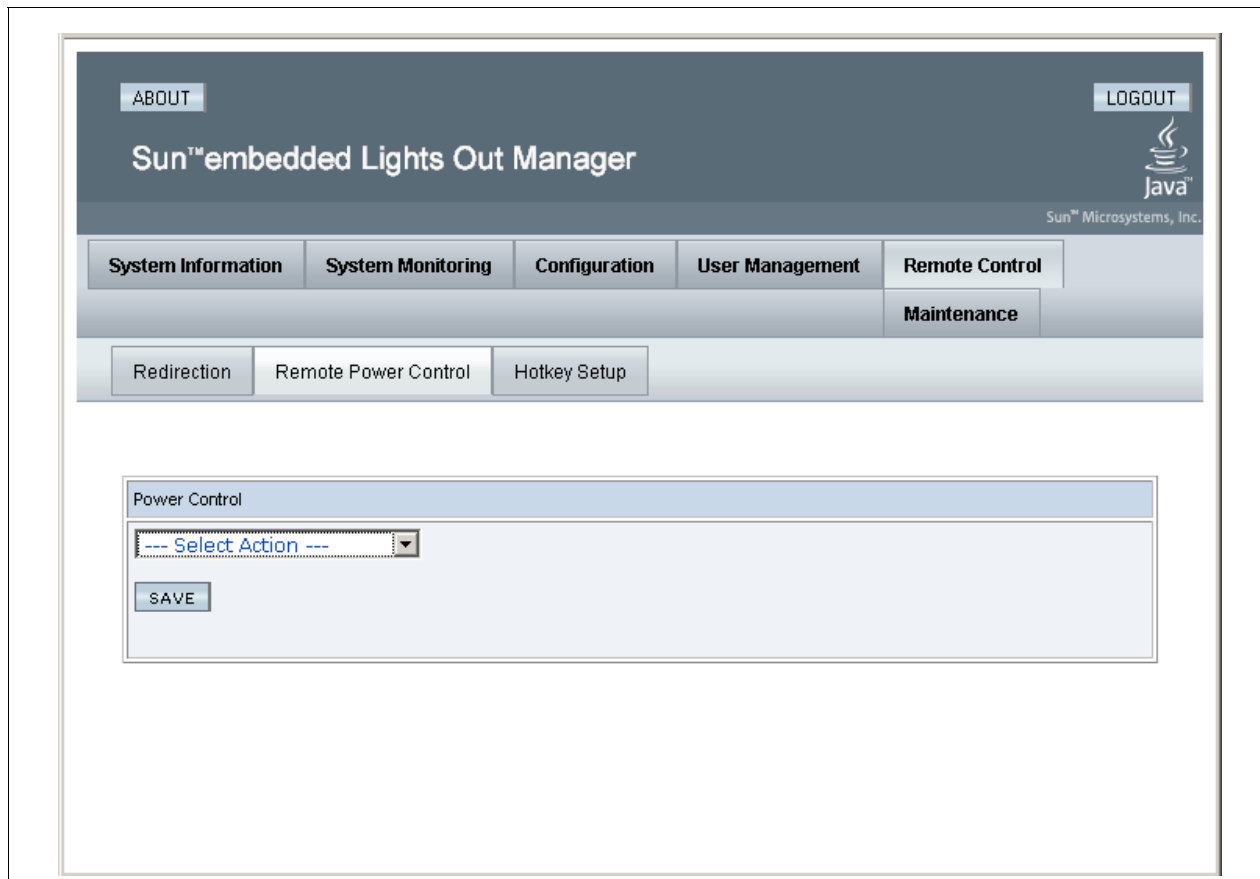
**FIGURE 2-4** Power Control

9. Click on the “Remote Control” tab in the first row of tabs.
10. Click on the “Redirection” tab in the second row of tabs
11. Click on the “Launch Redirection” button.  
This launches the remote console screen in a new window.

**FIGURE 2-5** Power Control

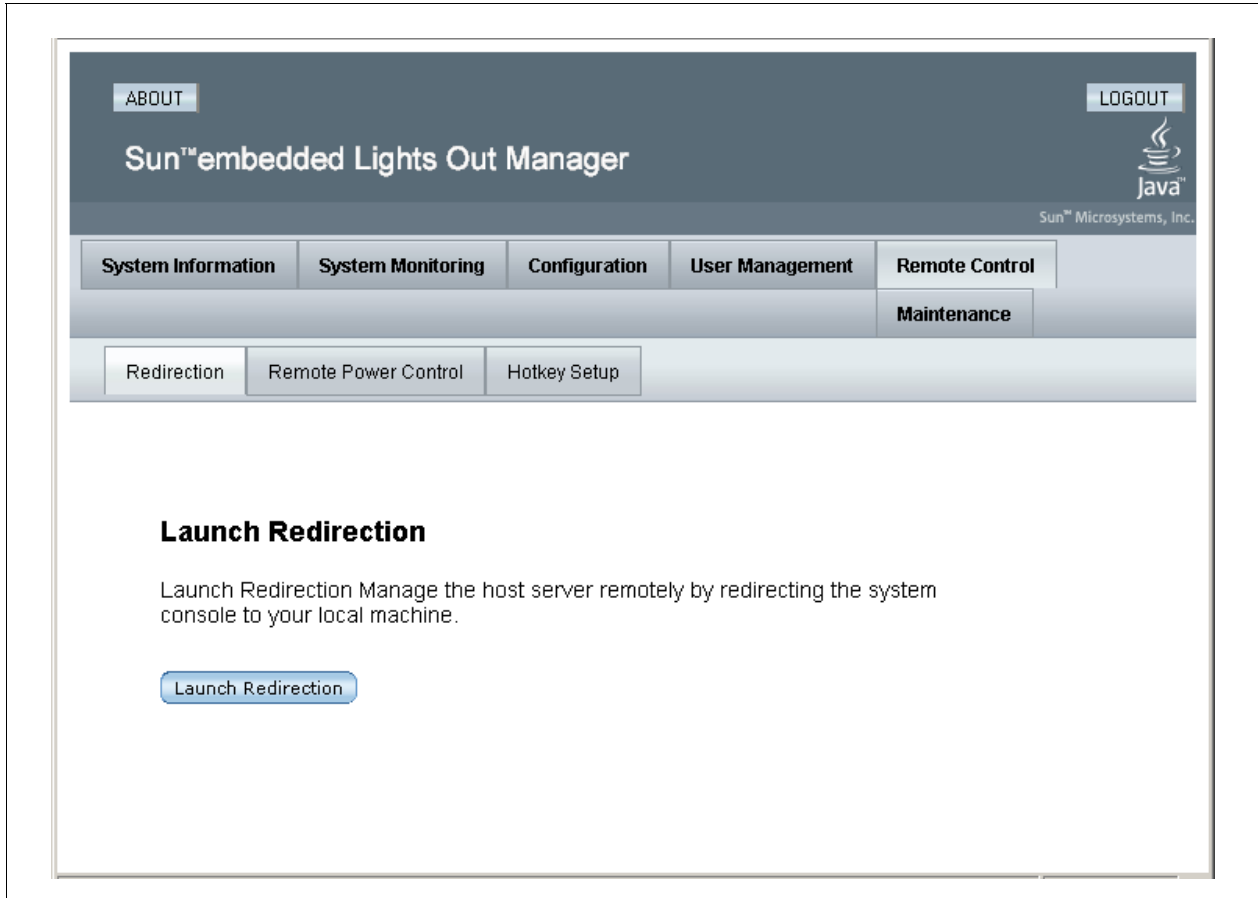

# QuickStart Program

When a new Key Management Appliance with the factory-default settings is powered-on for the first time, a Configuration Menu called QuickStart is automatically executed. QuickStart collects the initial, minimal configuration required to initialize the KMA.



Because of critical security parameters that are established by the QuickStart program, only a Security Officer or qualified representative should execute this program. Once the QuickStart program has been successfully completed, **it cannot be re-executed**. The only way to access this program again is to use the KMA reset command.

**Note** – A reset is performed by typing `reset` at the ELOM prompt after the “`set /SP/Agent...`” commands are complete and the DHCP and network address settings have been entered.

Also, at any point during the QuickStart program, entering [Ctrl+C] will abort the program clearing the settings and requires you to restart the program.

**Use the *Crypto Key Management System Administration Guide* (PN: 316195101) for specific information and instructions about the QuickStart program and Wizard.**

This guide provides configuration and administration information for the Sun Crypto Key Management System software.

This guide is intended for storage administrators, system programmers and operators responsible for configuring and maintaining the KMS software at their site.

The following information is needed before beginning the QuickStart program.



The customer may want to keep the User IDs, Passphrases, and Key Split Credentials defined during the QuickStart program—secret.

Use [TABLE 2-1 on page 4](#) to help record and use this information.

1. Type of keyboard attached to the KMA (select from list).
2. Hostname, IP address, and netmask for the management network (LAN 0) and service network (LAN 2) if connected; DHCP can be used for both if desired.
3. The gateway should be accessible through the management network connection. This address is required if there is a router between the KMA and the KMS Manager.
4. DNS server IP address, if desired (optional).
5. Key split credentials, including the total number of splits, threshold number of splits, plus the userid and passphrase for each of the splits.
  - We recommend keeping this simple.
  - This information **cannot** be recovered from the system if it is lost.
  - Backups **cannot** be restored without this information.
  - Loss of this information **will** result in unrecoverable data.
6. Autonomous unlocking selection.
  - If yes, the KMA will automatically unlock after a reboot.
  - If no, the KMA will remain locked until manually unlocked.

Unlocking requires a quorum.

## Tips and Notes

Knowing the following tips and notes will help during the QuickStart program and initial configuration.

- **Be patient.** It may take one or two minutes for the IP address settings to take effect.
  - The Key Management Systems Manager GUI (graphical user interfaces) uses a customer created network and IP address—this is called the Management Network. The KMS manager interfaces with the KMAs using this interface.
  - The KMAs interface with the tape drives using the Service Network (in general) using the Ethernet switches from the accessory kits. The IP address range for the KMAs use: 172.18.18.2 through 172.18.18.59
  - If a Service Delivery Platform is installed, that IP address is 172.18.18.1
  - The default tape drive IP address is: 10.0.0.1

- **Use a simple set-up to start.**

When entering information such as the key split size, split threshold, and quorum, keep it simple and use initial values such as “1 of 1.” Once the structure of the KMAs and the KMS Cluster are complete, this information can be changed to the production values at a later time using the KMS manager.

This can help with and speed up the installation and configuration of the Key Management System.

For example: All users may not be available at the same time to enter in their IDs and Passphrases.

- The userids and passphrases should be enter by the **appropriate person** to keep them secure; they can also be changed later after the QuickStart program.
- The user names are arbitrary; however, use the conventions defined by security polices or practices.
- The length of the passphrases can be changed in the KMS Manager. The default is eight characters using three of the four styles: Small case, UPPER case, numbers, and special characters.
- KMAs in a Cluster **must** keep their clocks synchronized. Internally, all KMAs use UTC time (coordinated universal time).

If the customer prefers, there is an option in the KMS Manager that allows date and times to be adjusted to local time when displayed.

When the customer is not using an NTP server, the clocks on the KMAs may drift. As a best practices, customers can check and re-sync the clocks at least once a year.



**Important:**

**Do not perform a “Core Security Backup” when using simple settings.**

Wait until all user’s have entered their credentials, passphrases, production settings, and quorum details before creating a Core Security Backup for the first time.



## QuickStart Wizard

The following section shows examples of the QuickStart program for configuring the first KMA in a KMS Cluster.

- Response areas are shown in **bold**.
- The KMA names use **KMA- $x$**  (where  $x$  is a number for that KMA, [ $x$  of  $x$ ]).
- The KMA IP address range is: **172.18.18. $x$** —the default network for the SDP.  
The SDP site unit is 172.18.18.1—KMAs share addresses 172.18.18.2 through 59.
- The subnet mask for SDP is 255.255.254.0
- The KMS management network uses a hostname of: **KMSmgr**
- The KMS management network uses an IP address range of: **129.80.123.xxx**

**The exact prompts shown may differ from this example.**

```
Welcome to QuickStart!
```

```
The QuickStart program will guide you through
the necessary steps for configuring the KMA.
```

```
You may enter Ctrl-c at any time to abort; however,
it is necessary to successfully complete all steps in this initialization
program to enable the KMA.
```

```
Press Enter to continue:
```

```
Set Keyboard Layout
```

---

```
Press Ctrl-c to abort.
```

```
You may change the keyboard layout here.
```

```
Available keyboard layouts:
```

```
( 1) Albanian           ( 2) Belarusian       ( 3) Belgian
( 4) Bulgarian         ( 5) Croatian         ( 6) Danish
( 7) Dutch             ( 8) Finnish          ( 9) French
(10) German            (11) Icelandic        (12) Italian
(13) Japanese-type6   (14) Japanese         (15) Korean
(16) Malta_UK          (17) Malta_US         (18) Norwegian
(19) Portuguese       (20) Russian          (21) Serbia-And-Montenegro
(22) Slovenian        (23) Slovakian        (24) Spanish
(25) Swedish          (26) Swiss-French     (27) Swiss-German
(28) Taiwanese        (29) TurkishQ        (30) TurkishF
(31) UK-English       (32) US-English
```

```
The current layout is US-English.
```

```
Please enter the number for the keyboard layout : 32
```

```
The keyboard layout has been applied successfully.
```

```
Press Enter to continue:
```

**1. Set the KMA IP addresses:**

Note: It may take one or two minutes for these IP address settings to take effect.

A static IP Address configuration must be set in order for the KMA to communicate with other KMAs, Agents, or Users in your system.

Please enter the Management Network Hostname: **KMSmgr**

Do you want to use DHCP to configure the Management Network interface? [y/n]: **n**

Please enter the Management Network IP Address: **129.80.123.32**

Please enter the Management Network Subnet Mask: **255.255.254.0**

Please enter the Service Network Hostname: **SDP**

Do you want to use DHCP to configure the Service Network interface? [y/n]: **n**

Please enter the Service Network IP Address: **172.18.18.1**

Please enter the Service Network Subnet Mask: **255.255.254.0**

Please enter the Gateway IP Address (optional but necessary if this KMA is to communicate with an entity on a different IP Subnet): **129.80.123.254**

Please enter the Primary DNS Server IP Address (optional): **129.80.0.4**

Please enter the DNS Domain: **my.customer.com**

Applying network settings... Done.

The Network Configuration has been updated.

Press Enter to continue:

Press Ctrl-c to abort.

## 2. Initialize the KMA.

The KMA Name is a unique identifier for your KMA. This name should not be the same as the KMA Name for any other KMA in your cluster. It also should not be the same as any User Names or Agent IDs in your system.

Please enter the KMA Name: **KMA-1**

Press Enter to continue:

## 3. Configure the Cluster.

You can now use this KMA to create a new Cluster, or you can have this KMA join an existing Cluster. You can also restore a backup to this KMA or change the KMA Version.

Please choose one of the following:

- (1) **Create New Cluster**
- (2) Join Existing Cluster
- (3) Restore Cluster from Backup

Please enter your choice: **1**

Create New Cluster

#### 4. Enter Key Split Credentials

Notes:

- The key split size and split threshold be changed at a later time using the KMS manager. This allows a setting for "1 of 1."
- The userids and passphrases should be enter by the appropriate person to keep them secure; or they can also be changed later after the QuickStart program.

The Key Split credentials are used to wrap splits of the Core Security Key Material which protects Data Unit Keys.

When Autonomous Unlocking is not enabled, a quorum of Key Splits must be entered in order to unlock the KMA and allow access to Data Unit Keys.

A Key Split credential, consisting of a unique User Name and Passphrase, is required for each Key Split.

The Key Split Size is the total number of splits that will be generated.

This number must be greater than 0 and can be at most 10.

Please enter the Key Split Size: **1**

The Key Split Threshold is the number of Key Splits required to obtain a **quorum**.

Please enter the Key Split Threshold: **1**

Please enter the Key Split User Name #1: **user1**

Passphrases must be at least 8 characters and at most 64 characters in length.

Passphrases must not contain the User's User Name.

Passphrases must contain characters from 3 of 4 character classes (uppercase, lowercase, numeric, other).

Please enter Key Split Passphrase #1: **\*\*\*\*\***

Please re-enter Key Split Passphrase #1: **\*\*\*\*\***

Press Enter to continue:

Press Ctrl-c to abort.

## 5. Enter Initial Security Officer User Credentials

The user names are arbitrary; however, use the conventions defined by security policies or practices.

The Initial Security Officer User is the first User that can connect to the KMA via the KMS Manager. This User can subsequently create additional Users and administer the system.

Please enter a Security Officer User Name: **SecOfficer**

A Passphrase is used to authenticate to the KMA when a connection is made via the KMS Manager.

Passphrases must be at least 8 characters and at most 64 characters in length.

Passphrases must not contain the User's User Name.

Passphrases must contain characters from 3 of 4 character classes (uppercase, lowercase, numeric, other).

Please enter the Security Officer Passphrase: **\*\*\*\*\***

Please re-enter the Security Officer Passphrase: **\*\*\*\*\***

Press Enter to continue:

Press Ctrl-c to abort.

## 6. Enter Autonomous Unlocking Preference

When Autonomous Unlocking is DISABLED, it is necessary to UNLOCK the KMA using a quorum of Key Split Credentials EACH TIME the KMA starts before normal operation of the system can continue. Agents may NOT register Data Units with or retrieve Data Unit Keys from a locked KMA.

When Autonomous Unlocking is ENABLED, the KMA will automatically enter the UNLOCKED state each time the KMA starts, allowing it to immediately service Agent requests.

Do you wish to enable Autonomous Unlocking? [y/n]: **y**

## 7. Set Time Information.

KMAs in a Cluster **must** keep their clocks synchronized. Internally, all KMAs use UTC time (coordinated universal time).

If the customer prefers, there is an option in the KMS Manager that allows date and times to be adjusted to local time when displayed.

```
KMAs in a Cluster must keep their clocks synchronized. Specify an
NTP server if one is available in your network. Otherwise, specify
the date and time to which the local clock should be set.
```

```
Please enter the NTP Server Hostname or IP Address (optional):
```

```
ntp.example.com
```

```
Press Enter to continue:
```

```
Initializing new cluster...
```

```
New KMS cluster has been created.
```

```
Press Enter to continue:
```

```
Key Management System Version Build 321
```

---

```
KMA initialization complete!
```

```
You may now connect to the KMA via the KMS Manager in order to
continue with KMS configuration.
```

```
Press Enter to exit:
```

```
Key Management System Version Build 321 (KMA-1)
```

---

```
Please enter your User Name:
```

## 8. Install the KMS Manager.

# Configuration Checklist

The following is a list of tasks the customer or user would do to configure and use the Sun Crypto Key Management System Version 2.0.

They are listed here as a checklist to assist the user with the initial configuration and familiarization of the KMS Manager.

Make sure the customer or user has a copy of the:

***Crypto Key Management System Administration Guide (PN: 316195101) for specific information and instructions about how to configure the KMA Cluster.***

**TABLE 2-5** Initial Configuration Checklist

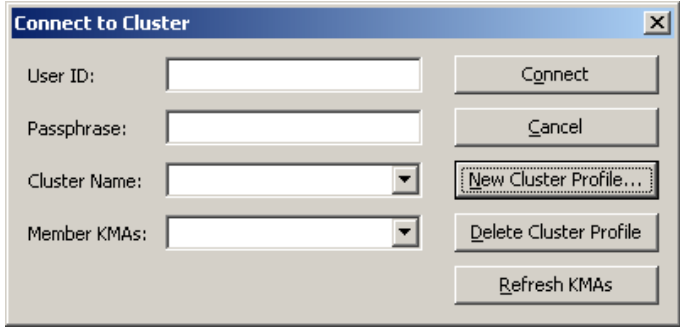
✓	Task	Guidelines
❑	<b>Install the KMS Manager</b>	<p>In order to continue with KMA setup, the KMS Manager GUI must be installed. Currently, only Windows XP, Solaris 10 Update 3x86 and Update 4x86 versions are supported. Windows Vista and Solaris 9 are not supported.</p> <p>Initially, the KMS Manager will be blank until there is a KMA Cluster in which to connect.</p> <p><b>Note:</b> The first time trying to connect you may get a message stating that the:  <b>Web Site Certified By Unknown Authority</b>                      and offer selections to choose from. Select either Accept Temporary or Accept Permanent. Click on one of these options and then click OK. This is a normal message.</p>
❑	<b>Create a KMA Cluster</b>	<ol style="list-style-type: none"> <li>1. Click on the Connect button in the upper left corner.</li> <li>2. Click on New Cluster Profile...</li> </ol> <div style="text-align: center;">  </div> <ol style="list-style-type: none"> <li>3. Enter a name for the cluster</li> <li>4. Enter the IP address or hostname or any KMA in the cluster</li> <li>5. Click OK</li> </ol>
❑	<b>Log in as the Security Officer</b>	<ul style="list-style-type: none"> <li>■ Use the Security Officer login from the QuickStart program.</li> <li>■ Enter the cluster name created above.</li> </ul> <p>The Main GUI screen is displayed.</p>

**TABLE 2-5** Initial Configuration Checklist

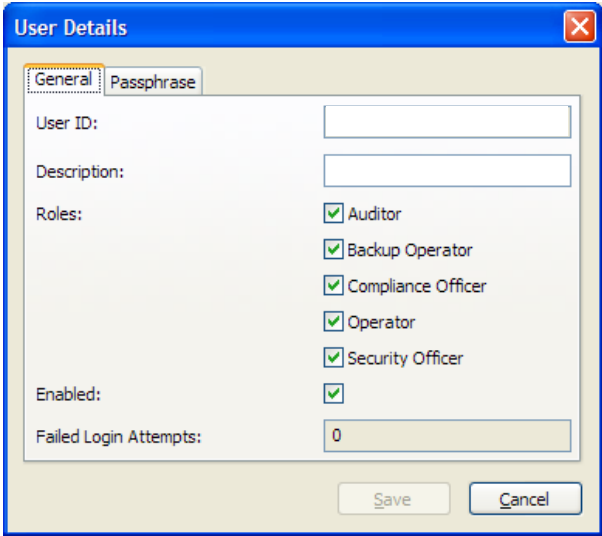
✓	Task	Guidelines
☐	<b>Create additional users</b>	<p>From the Main Screen, in the left pane:</p> <ol style="list-style-type: none"> <li>1. Select: System Management ⇨ User List</li> <li>2. Click Create and complete the necessary information</li> <li>3. Click Save</li> </ol> 
<p>User IDs and Passphrases will be needed for the following roles.                      If all users are not available at the time of this initial configuration, they can add their names and passphrases afterwards.                      However, do not create a Core Security Backup until this has been completed.</p>		
<b>Auditors</b>		Names:
<b>Backup Operators</b>		Names:
<b>Compliance Officers</b>		Names:
<b>Operators</b>		Names:
<b>Security Officers</b>		Names:



**TABLE 2-5** Initial Configuration Checklist

✓	Task	Guidelines
☐	<b>Create Key Policies and Key Group Configurations</b>	<p>You need to create at least:</p> <ul style="list-style-type: none"> <li>■ One key policy</li> <li>■ One key group</li> </ul> <p>Then:</p> <ul style="list-style-type: none"> <li>■ Assign the key group to the key policy</li> </ul>
☐	<b>Enroll Agents</b>	<p>This is a two step process:</p> <ul style="list-style-type: none"> <li>■ One Step is performed at the KMS Manager. <ul style="list-style-type: none"> <li>■ Use <a href="#">TABLE 3-4 on page 35</a> to record the information</li> <li>■ Agent ID and passphrase</li> <li>■ IP address</li> </ul> </li> </ul> <p>At the KMS Manager, navigate to the agent list: Secure Information Management ⇄ Agents ⇄ Agent List</p> <div data-bbox="743 747 1344 1228" style="border: 1px solid black; padding: 5px; margin: 10px 0;"> </div> <ul style="list-style-type: none"> <li>■ The other Step is performed at the Tape Drives <ul style="list-style-type: none"> <li>■ Use <a href="#">TABLE 3-3 on page 34</a> record the information</li> <li>■ Drive serial number</li> <li>■ IP address</li> <li>■ Location</li> </ul> </li> </ul>
☐	<b>Assign Agents to the Key Groups</b>	<p>At the KMS Manager, navigate to: Secure Information Management ⇄ Agents ⇄ Key Group Assignment</p> <ol style="list-style-type: none"> <li>1. Click the Agent in the list to display its key group permissions</li> <li>2. Select the key group</li> <li>3. Click “Default Key Group” button to move this to the key group.</li> </ol>

**TABLE 2-5** Initial Configuration Checklist

✓	Task	Guidelines
		
□	<p><b>Configure the Agent</b></p>	<ol style="list-style-type: none"> <li>1. Set the IP address of the drive</li> <li>2. Provide the Drive ID, Passphrase, and the IP address of one of the KMA's in the cluster. The details are device specific.</li> <li>3. Once this process has been successfully completed, the agent will show as “enrolled” in the agent details screen.</li> </ol> 

TABLE 2-5 Initial Configuration Checklist

✓	Task	Guidelines
<input type="checkbox"/>	<p><b>Preform the Initial Backup</b></p> <p>This is a 2-step process that creates three files:</p> <ul style="list-style-type: none"><li>■ Core Security file</li><li>■ Backup Key file</li><li>■ Backup file</li></ul>	<p>The steps to perform a backup are not necessary for a multi-KMA cluster. They certainly can be done, but they are not required.</p> <p>Before keys can be created and delivered, backups must be performed to ensure they are protected. When the KMA is first brought up, it begins generating keys; Initially 1000 keys.</p> <p>To verify this, from the Main Screen, in the left pane:</p> <ol style="list-style-type: none"><li>1. Select: System Management ⇨ KMA List</li><li>2. Double click on the KMA or click the "Details..." button<ul style="list-style-type: none"><li>■ "Ready Keys" should be 0.</li><li>■ "Generated Keys" should be 1000.</li></ul></li></ol> <p>Later on in the process, this will change (reverse).</p> 

**TABLE 2-5** Initial Configuration Checklist

✓	Task	Guidelines
☐	<b>Backup: First Step</b>	<p>The initial Backup is a two step process.</p> <p>First step of the backup is to create a Core Security Backup.</p> <ol style="list-style-type: none"> <li>1. As the Security Officer, select: System Management ⇨ Security ⇨ Core Security ⇨ Backup Core Security</li> <li>2. Choose a file and click Start. Using the default name is recommended, but any directory can be selected. This creates a Core Security Backup file on the system where the KMS Manager is being used.</li> <li>3. Navigate to the backup list from the Main Screen, select: Secure Information Management ⇨ Backup List</li> </ol>
☐	<b>Backup: Second Step</b>	<p>Second step of the backup is to:</p> <ol style="list-style-type: none"> <li>1. Login using a Backup Operator role.</li> <li>2. Click the Create Backup... button.</li> <li>3. Choose files for the two outputs.</li> <li>4. Use of the defaults for filenames is recommended, but these can be placed in any desired directory.</li> <li>5. Click Start</li> </ol> <div data-bbox="699 957 1398 1339" style="border: 1px solid black; padding: 5px; margin: 10px 0;"> <p><b>Create Backup</b> <span style="float: right;">✕</span></p> <p>Backup File Name:  <input type="text" value="H:\KMS-Backup-[BackupID]-[DateTime].dat"/> <input type="button" value="Browse..."/></p> <p>Backup Wrapping Key File Name:  <input type="text" value="H:\KMS-Backup-Key-[BackupID]-[DateTime].xml"/> <input type="button" value="Browse..."/></p> <p style="text-align: center;"> <input type="button" value="Start"/> <input type="button" value="Close"/> </p> </div> <p><b>Note:</b> Now the system will show:</p> <ul style="list-style-type: none"> <li>■ "Ready Keys" 1000.</li> <li>■ "Generated Keys" 0.</li> </ul>
<p>Note: The frequency for performing backups depends on the number of tape mounts and key usage—how fast are the keys being used? <i>Each</i> KMA starts with 1000 keys—as mounts occur, the keys are used. The systems tracks key usage and adjusts the supply of keys. As a best practices, backups should be taken weekly; however, again, this all depends on key usage.</p>		

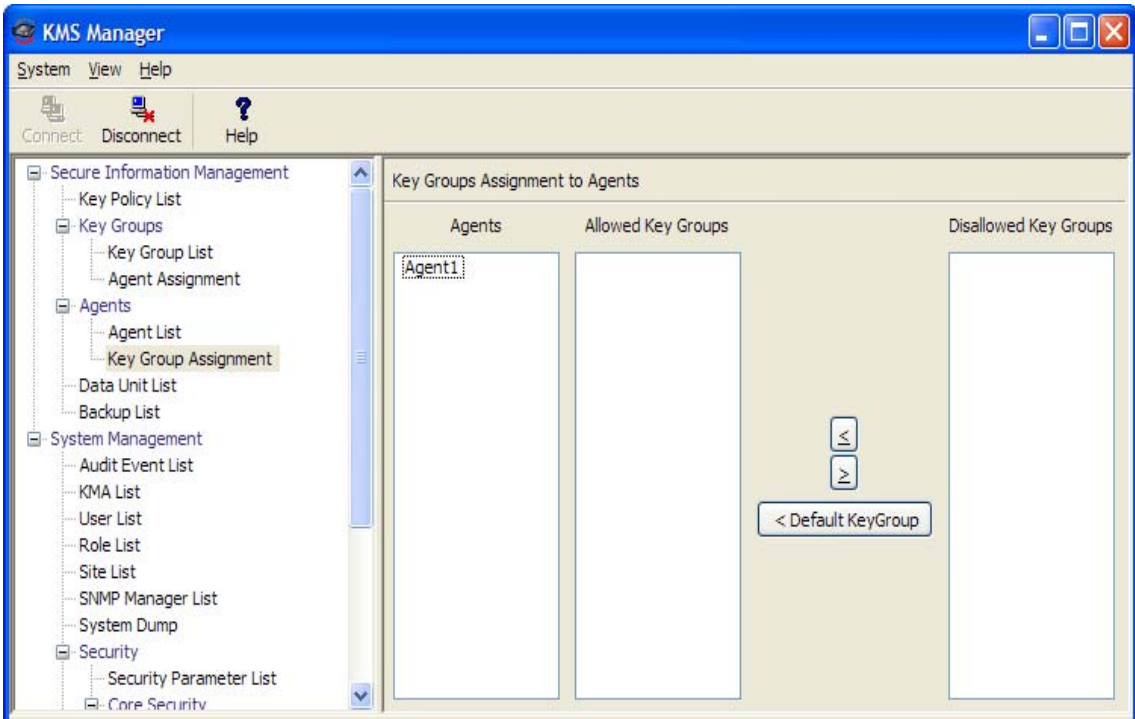
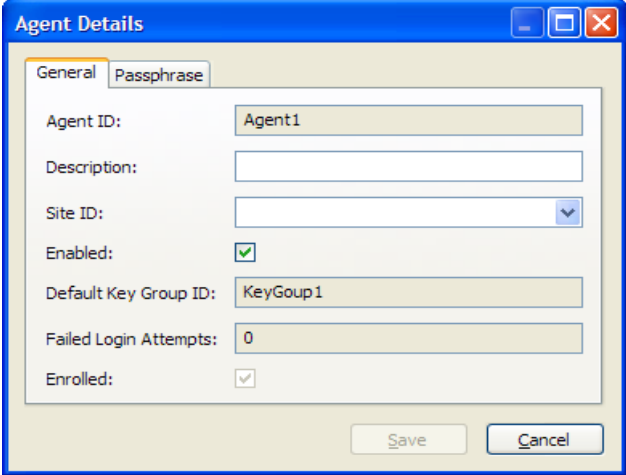
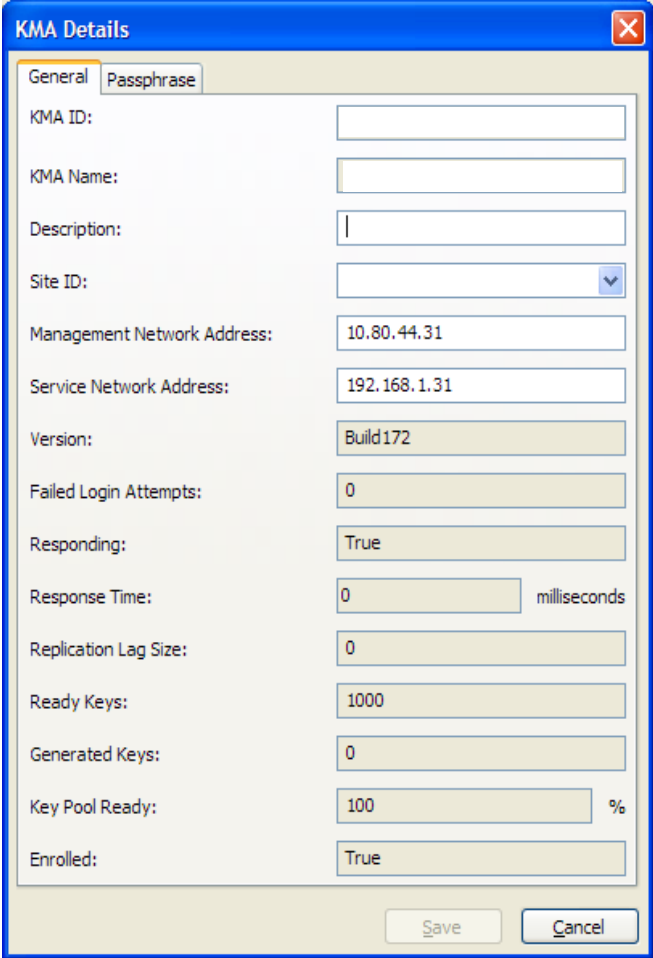
## Change the ELOM Password

For security, at some point, the customer needs to change the ELOM password.

ELOM provides functionality that can be used to perform a network boot of the KMA. This functionality could be exploited and provide access to key material on the KMA hard drive. Because of this potential, the user should change and secure the root password of the ELOM.

A good time to do this is after completing the QuickStart program.

### To change the ELOM password:

1. Access the ELOM network (LAN 1).
2. Select: User Management ⇨ User Account to bring up the account list.
3. Click on the Change Password on the root user name.
4. Enter the Old Password (the default is “changeme”)
5. Enter a new Password and Confirm the password.
6. Click Submit.

**FIGURE 2-6** ELOM Password Reset

The figure consists of two screenshots from the ELOM web interface. The top screenshot shows the navigation menu with 'User Management' selected, leading to the 'User Account' sub-menu. Below this is a 'User List' table with columns for Username, Privilege, and Status. The 'root' user is listed with Administrator privilege and Enabled status. A 'Change Password' button is visible next to the 'root' user, along with an 'Add User' button at the bottom of the table.

Username	Privilege	Status
root	Administrator	Enabled

The bottom screenshot shows the 'Manage User Account' form. It contains three input fields: 'Old Password', 'Password', and 'Confirm'. Below the input fields are 'Submit' and 'Reset' buttons.

## Add KMAs to the Cluster



Servers *must be* installed in pairs called a cluster. Clusters perform backups of each appliance; therefore, no external hard drives are required.

- Adding another KMA to the first one created above requires some steps inside the existing cluster using the KMS Manager (GUI).
- Then, during the QuickStart program for the next KMA, select:
  - (2) **Join Existing Cluster**
- After that, the QuickStart program prompts for the Passphrase and IP address of that existing cluster.

### To create and add another KMA to the cluster:

1. Log in to the KMS manager.
2. Select System Management ⇨ KMA List ⇨ Create button.  
The Create KMA dialog box is displayed, with the General tab active.
3. Complete the following parameters:
  - **KMA Name:** Type a value that uniquely identifies the KMA in a cluster.  
This value can be between 1 and 64 (inclusive) characters.
  - **Description Type:** A value that uniquely describes the KMA.  
This value can be between 1 and 64 (inclusive) characters.
  - **Site ID** Click the down-arrow and select the site to which the KMA belongs.  
This field is optional.
4. Open the Passphrase tab.
5. Enter the Passphrase. Enter from 8 to 64 characters. The default value is 8 characters.
6. Confirm Passphrase. Retype the same value that you entered in the Passphrase field.
7. The KMA record is added to the database and the entry is displayed in the KMA List screen.
8. Add all other KMAs belonging to the Cluster.
9. You must now run the QuickStart program on the KMA(s) you just created so that they can join the Cluster. See [“QuickStart Program” on page 13](#) for information.  
Remember to select Option 2 to Join an Existing Cluster.
10. After completing the QuickStart, the KMA will be locked. You must reconnect to the new KMA (you may need to do a “refresh”) to unlock it.

## Run the QuickStart Wizard

1. You must now run the QuickStart program on the KMA you just created so that they can join the Cluster.

- See “[QuickStart Program](#)” on page 13 for information.
- Remember to select Option 2 to Join an Existing Cluster.

The KMA being added checks the firmware version against the existing versions in the cluster.

If it is not compatible, the new KMA displays an error and gives the user the option of upgrading or downgrading.

**FIGURE 2-7** KMA Replacement—Joining a Existing Cluster

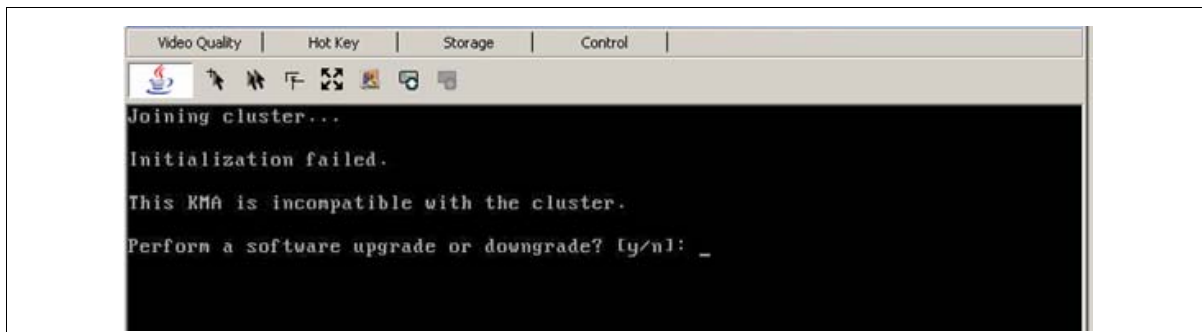

2. If the user selects “Yes”, then the KMA being added:

- Grabs the code from the existing KMA in the cluster,
- Downloads the code for its own, and
- Installs the code.

This process takes about 25 to 30 minutes to complete.

**FIGURE 2-8** KMA Replacement—Joining a Existing Cluster

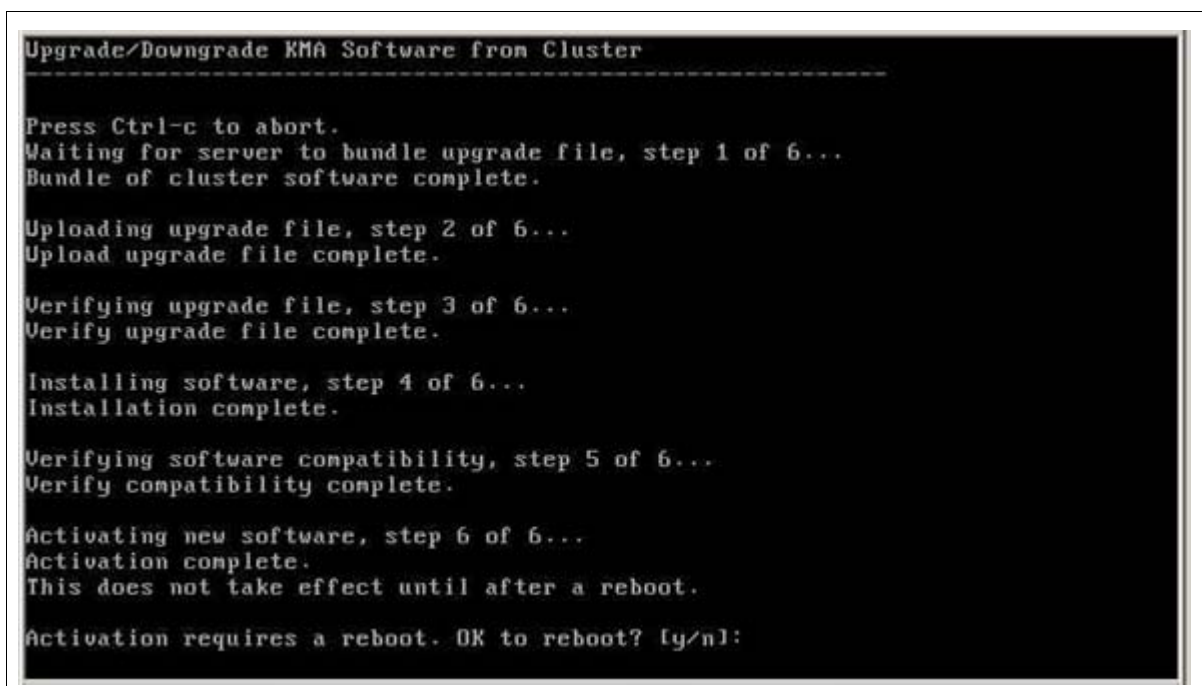

3. Once this process completes, the User needs to reboot the KMA.
4. After the KMA comes back online from the reboot, you need to continue with the QuickStart program.
5. Check that the new KMA is in service, select: System Management ⇔ KMA List.

**Once all the KMAs are in the KMA List, go to:**

- [“Configuration Checklist” on page 21](#) to continue with the initial configuration. This is a list of “user” tasks that the must customer perform. The checklist is provided to assist the service representative and customer as they go through the initial configuration.  
Make sure the KMS Administrator Guide is available for use.
- [Chapter 3, “Tape Drives”](#) to license and enroll the tape drives. This chapter requires both service representative and user tasks to complete.
- [Chapter 4, “Encryption Hardware Kits”](#) to install the additional hardware in the customer-select solution. This chapter requires just the service representative to install the additional hardware (such as Ethernet switches and cables).



## Tape Drives

Currently, the Crypto Key Management Station Version 2.0 supports:

**TABLE 3-1** Tape Drive Support

Tape Drive Type	Interface Type	Firmware Version	Configuration Notes
T10000 A	<ul style="list-style-type: none"> <li>■ Fibre Channel</li> <li>■ FICON</li> </ul>	1.37.108 1.37.114	<ul style="list-style-type: none"> <li>■ Not supported in an SL500 library</li> </ul>
T9840D	<ul style="list-style-type: none"> <li>■ FICON</li> <li>■ ESCON</li> <li>■</li> </ul>	1.42.104	<ul style="list-style-type: none"> <li>■ Not supported in an SL500 library</li> </ul>

This chapter contains information about how to:

- [Obtain the Drive Data](#)—PC Key
- [License the Tape Drives](#)
- [Enroll the Tape Drives](#)—called Agents—on the Key Management Appliances



For specific information about how to install the tape drives in the appropriate configuration, refer to:

<i>T10000 Tape Drive Installation Manual</i>	StorageTek: 96173
<i>T10000 Service Manual</i>	StorageTek: 96175
<i>Virtual Operator Panel—Service</i>	StorageTek: 96180
<i>Virtual Operator Panel—Customer</i>	StorageTek: 96179
<i>T9x40 Tape Drive Installation Manual</i>	StorageTek: 95879
<i>T9x40 Service Manual</i>	StorageTek: 95740
<i>HP LTO4 Documentation</i>	HP Online Site

If the manuals are not on hand, go to the Product Documentation Web site at:

<http://docs.sun.com/app/docs>

## Before Beginning



### Important:

1. The tape drives should be installed and tested in the appropriate configuration before adding the encryption capability to them.
2. To enable and enroll the tape drives requires multiple steps and the **collaboration** between the service representative and the customer to complete.

Responsibility	Steps
Customer	1. Create Agent IDs and passphrases in the KMAs
Service Representative	1. Request the PC Keys from the Web site

Service Representative	2. Download the PC Keys to the tape drives
	3. License the tape drives
Customer	4. Enroll the tape drives
	6. Assign the tape drives to a Key Group

- **The service representatives** will need to create a file on a laptop and use the Virtual Operator Panel (VOP) to transfer the PC Keys to license the tape drives. Record the information in [TABLE 3-3 on page 34](#)
- **The customer** will need to use the Virtual Operator Panel (VOP) to provide an Agent ID and Pass Phrase to enroll the tape drives on the key management appliance (KMA). Gather and record the enrollment data in [TABLE 3-4 on page 35](#)
- Make copies as necessary.

## Required Tools

The required tools to obtain the drive data, license and enroll the tape drives is:

- Straight Ethernet cable, 10 ft (PN: 24100216)  
if using an Ethernet switch to connect to the tape drives
- Cross-over Ethernet cable, 10 ft (PN: 24100163)  
if connecting directly to the tape drives
- Service laptop (or personal computer)
- Virtual Operator Panel, Version 1.0.11 or higher (service and customer versions)

## Tape Drive LEDs

Each encryption-capable tape drive has an LED status light on the rear of the drive and/or drive tray.

**TABLE 3-2** Tape Drive Encryption LED

Encryption Status LED:	Encryption LED
<p><b>Green:</b></p> <ul style="list-style-type: none"> <li>■ Solid—Safe, encryption is <i>not</i> enabled</li> <li>■ Flashing—Reset, encryption was enabled, now it needs keys</li> </ul> <p><b>Amber (orange):</b></p> <ul style="list-style-type: none"> <li>■ Solid—Needs media keys (install the OKT)</li> <li>■ Flashing—Needs device keys (install the EKT). <i>This also indicates a IP address mismatch on the token/drive network.</i></li> </ul> <p><b>Red:</b></p> <ul style="list-style-type: none"> <li>■ Solid—Armed, ready to encrypt</li> <li>■ Flashing—Encrypting, reading and writing in encrypted mode.</li> </ul> <p><b>Cycling:</b></p> <p>The LED is cycling through all colors. This indicates the tape drive is “<b>zeroed</b>,” unusable, and must be returned.</p>	<p>The diagram shows the rear panel of a tape drive. It features a central VHS connector, two circular fan-like components on either side, and a row of ports at the bottom. A small LED is labeled '1' and an Ethernet port is labeled '2'.</p> <p style="text-align: right;">T105_011</p>
<p>1. Encryption LED 2. Ethernet Port</p>	
<p><b>Note:</b> Where there is no cartridge in the tape drive, the drive has no encryption keys stored in memory</p>	

# Service Representative Work Sheet

**TABLE 3-3** Drive Data Work Sheet

SDP IP Address:		File Pathname:	Location:
Serial Number / DMOD (Last 8 digits)	Crypto Serial Number (6 hexadecimal characters)	Drive IP Address	
1.			
2.			
3.			
4.			
5.			
6.			
7.			
8.			
9.			
10.			
11.			
12.			
13.			
14.			
15.			
16.			
17.			
18.			
19.			
20.			

# Customer Work Sheet

TABLE 3-4 Enrollment Data Work Sheet

KMA Hostname: KMA IP Address:		KMA Hostname: KMA IP Address:		KMA Hostname: KMA IP Address:		KMA Hostname: KMA IP Address:	
Drive Address	Drive IP Address	Agent ID	Passphrase	Tokens? (KMS 1.x)	Permanent?		
1.				Yes <input type="checkbox"/> No <input type="checkbox"/>	Yes <input type="checkbox"/> No <input type="checkbox"/>		
2.				Yes <input type="checkbox"/> No <input type="checkbox"/>	Yes <input type="checkbox"/> No <input type="checkbox"/>		
3.				Yes <input type="checkbox"/> No <input type="checkbox"/>	Yes <input type="checkbox"/> No <input type="checkbox"/>		
4.				Yes <input type="checkbox"/> No <input type="checkbox"/>	Yes <input type="checkbox"/> No <input type="checkbox"/>		
5.				Yes <input type="checkbox"/> No <input type="checkbox"/>	Yes <input type="checkbox"/> No <input type="checkbox"/>		
6.				Yes <input type="checkbox"/> No <input type="checkbox"/>	Yes <input type="checkbox"/> No <input type="checkbox"/>		
7.				Yes <input type="checkbox"/> No <input type="checkbox"/>	Yes <input type="checkbox"/> No <input type="checkbox"/>		
8.				Yes <input type="checkbox"/> No <input type="checkbox"/>	Yes <input type="checkbox"/> No <input type="checkbox"/>		
9.				Yes <input type="checkbox"/> No <input type="checkbox"/>	Yes <input type="checkbox"/> No <input type="checkbox"/>		
10.				Yes <input type="checkbox"/> No <input type="checkbox"/>	Yes <input type="checkbox"/> No <input type="checkbox"/>		
11.				Yes <input type="checkbox"/> No <input type="checkbox"/>	Yes <input type="checkbox"/> No <input type="checkbox"/>		
12.				Yes <input type="checkbox"/> No <input type="checkbox"/>	Yes <input type="checkbox"/> No <input type="checkbox"/>		
13.				Yes <input type="checkbox"/> No <input type="checkbox"/>	Yes <input type="checkbox"/> No <input type="checkbox"/>		
14.				Yes <input type="checkbox"/> No <input type="checkbox"/>	Yes <input type="checkbox"/> No <input type="checkbox"/>		
15.				Yes <input type="checkbox"/> No <input type="checkbox"/>	Yes <input type="checkbox"/> No <input type="checkbox"/>		
16.				Yes <input type="checkbox"/> No <input type="checkbox"/>	Yes <input type="checkbox"/> No <input type="checkbox"/>		
17.				Yes <input type="checkbox"/> No <input type="checkbox"/>	Yes <input type="checkbox"/> No <input type="checkbox"/>		
18.				Yes <input type="checkbox"/> No <input type="checkbox"/>	Yes <input type="checkbox"/> No <input type="checkbox"/>		
19.				Yes <input type="checkbox"/> No <input type="checkbox"/>	Yes <input type="checkbox"/> No <input type="checkbox"/>		
20.				Yes <input type="checkbox"/> No <input type="checkbox"/>	Yes <input type="checkbox"/> No <input type="checkbox"/>		

## Obtain the Drive Data

To obtain the drive data for *each* tape drive:

1. Using the Virtual Operator Panel, connect to each tape drive and record the last *eight* digits of the tape drive serial number.
  - Select: File ⇔ Connect to Drive
  - Select: Retrieve ⇔ View Drive Data ⇔ Manufacturing

**FIGURE 3-1** Tape Drive Serial Number—VOP

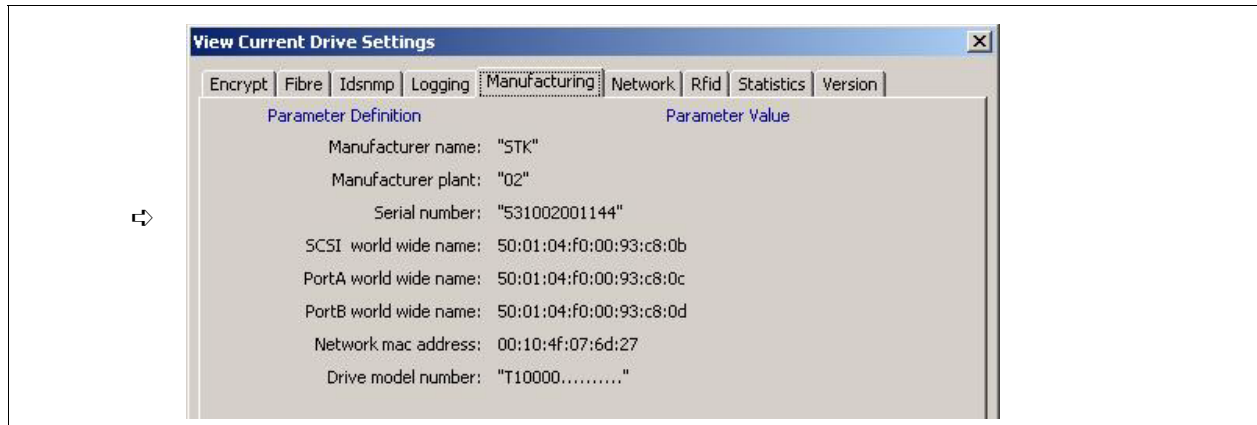

2. Use [TABLE 3-3 on page 34](#) to build information about the tape drives. You will find this information helpful during the installation, licensing, and enrollment process for the tape drives (agents).
3. Request an Encryption Key File:
  - a. Log in to the Applications Web site at: <http://craapplications/keyswebapp/>
  - b. Select Request an Encryption key.

**FIGURE 3-2** Request an Encryption Key Application



**Access is Limited:** You must be a Sun employee, have completed the training courses, and have your name included on the list to access this link.

4. Complete the Encryption Request form.
  - a. First name, last name, and e-mail address are automatically included.
  - b. Provide a site ID and order number.
  - c. Select the tape drive type (T10000A, T10000B, or T9840D).
  - d. Complete the serial number for the selected tape drive.
  - e. Add any optional remarks and click Request Key File.  
 After submitting the Encryption File Request you will be prompted to download the file. This file contains the drive data you need to enable and enroll the drive.

FIGURE 3-3 Encryption File Request for Drive Data

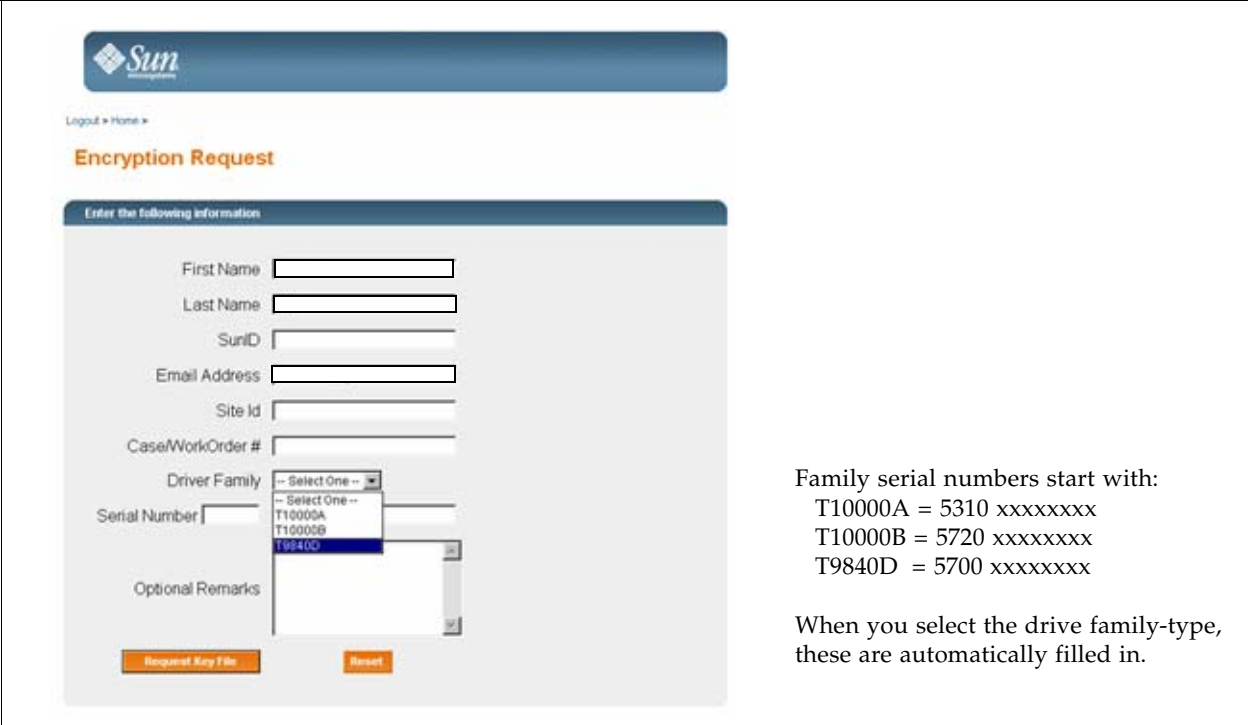

5. Continue with this process until you obtain all the drive data files for each tape drive you are going to enable.
- If you open the drive data file, using WordPad for example, you can see and verify the drive serial number, PCKey, and crypto serial number (CSN).

FIGURE 3-4 Encryption File Request for Drive Data

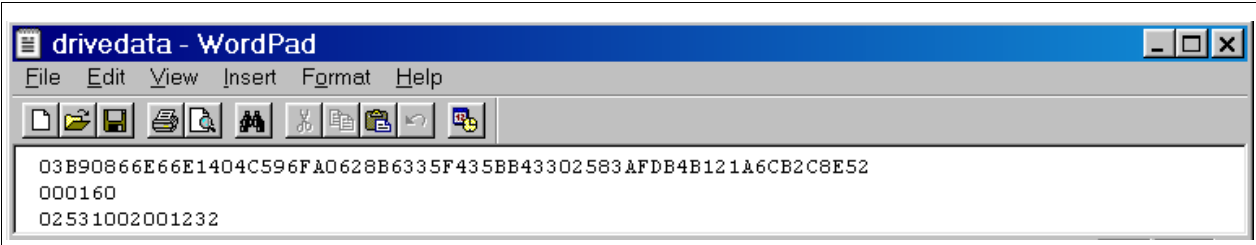

## Create a Drive Data File Structure

When enabling multiple drives, it is best to create a file structure where each tape drive has its own folder. For example:

1. [FIGURE 3-5](#) uses a top-level folder name of **crypto\_drvs** placed on the Desktop. (This is only for grouping of the other folders.)
2. Under **crypto\_drvs** are the folders for each tape drive using the serial numbers.
3. In each serial number folder is the drive data file for that specific tape drive.

**FIGURE 3-5** Drive Data File Structure

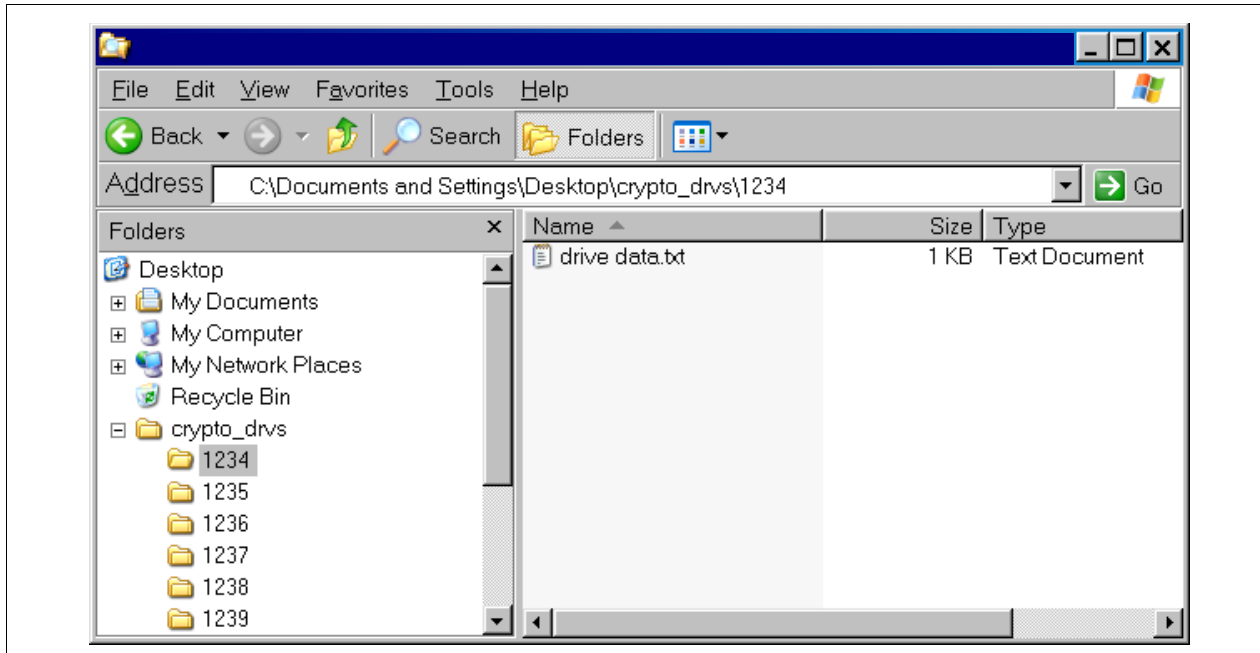

When licensing the tape drives, the VOP requests a download location.

4. Complete [TABLE 3-4 on page 35](#) to help with the licensing and enrollment of the tape drives. What you need to know before beginning:
  - What is the drive number (serial or system) and IP address?
  - What are the Agent IDs and Passphrases?
  - Is this drive going to use **tokens** (KMS Version 1.x) to get media keys (OKT)?  
Or use the **appliance** (KMA Version 2.x) to get the encryption keys?
  - Does the customer want this drive to remain in encryption mode?  
Or do they want the ability to switch encryption on and off?
5. Make copies of this page as necessary.

### Notes:

- Agent names (IDs) cannot be changed; however, an agent can be deleted and re-enrolled it with a different name.
- If you replace the agent, you can reuse the name; however, passphrases can only be used once, you will need to give the agent a new passphrase.
- Which means, the replacement drive will need to be enrolled using the existing name and a new passphrase.



## License and Enroll the Tape Drives

Once the drive data is downloaded for all the tape drives, use the Virtual Operator Panel (VOP) to license and enable encryption on the tape drives.



The following procedures assume you know how to connect to and use the VOP on the T10000 tape drives. If not, refer to the Virtual Operator Panel documentation for help.

The following procedure requires *both* the:

- Service representative: To download the drive data (PC Key) and the
- Customer: To enroll the Agent (ID and Pass Phrase)

### License the Tape Drives

For the service representative:

1. Configure and connect the laptop with the drive data file structure to the:
  - Tape drive network using an Ethernet cable and switch (using the assigned IP addresses for the drives)
  - Tape drive using a cross-over Ethernet cable (using the default IP address 10.0.0.1)
2. Launch VOP and connect to a specific tape drive.
3. On the VOP main screen:
  - Take the drive offline.
  - Pull down the Configure menu.
  - Select Drive Data.

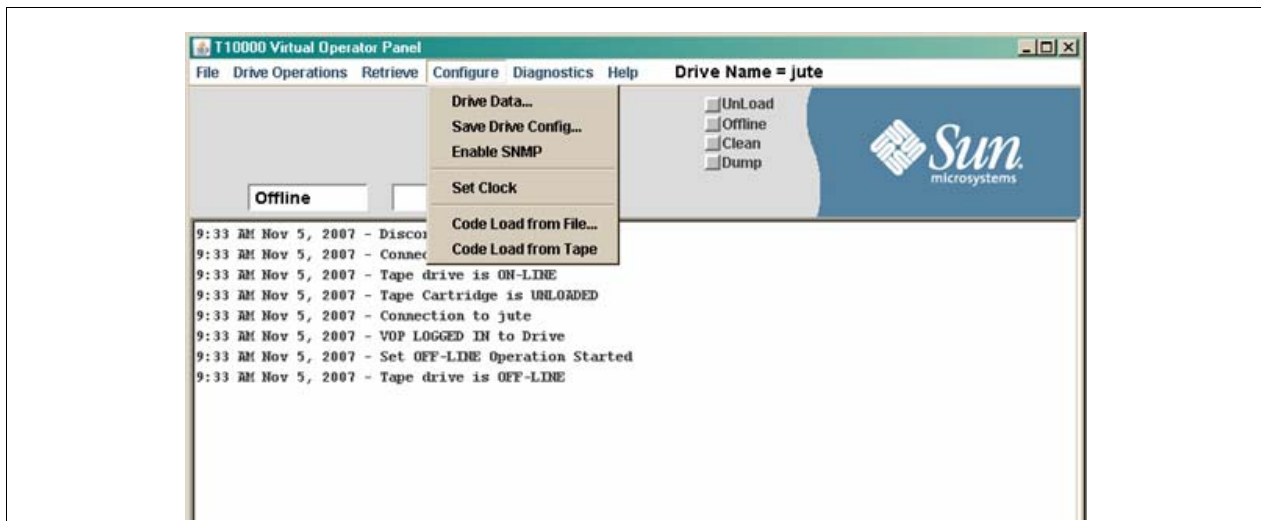

4. Press the License button and a File Open screen appears.

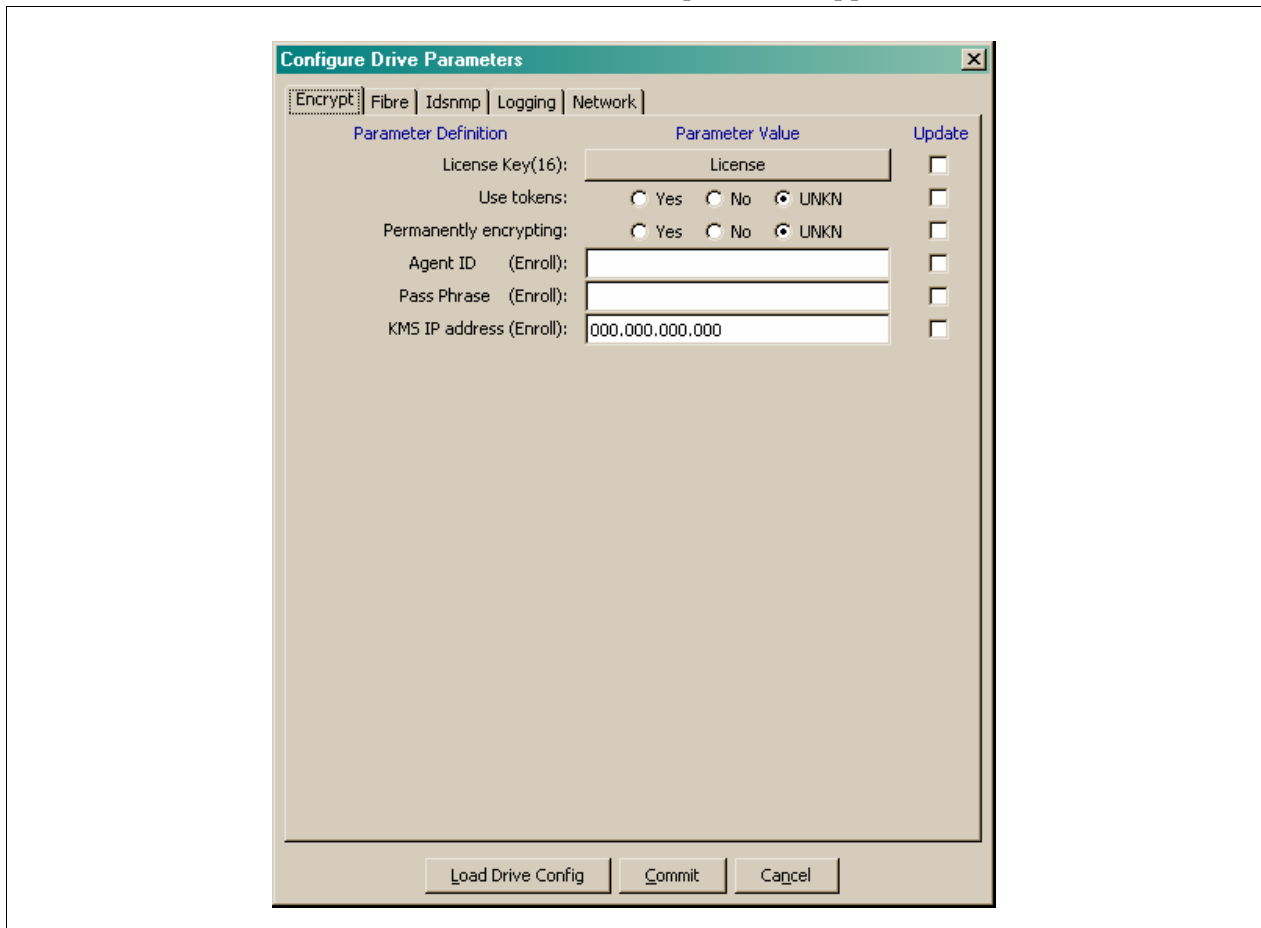

5. Navigate to the drive data file structure and select the folder for that tape drive.

The drive validates the license number:

- If it is not correct licensing will fail and VOP will show an error message.
- If the license number is correct, the drive will reboot.

Depending on the number of tape drives to license, the service representative may want to license all drives before the customer enrolls them.

Depending on the number of tape drives, this can take time to license and enroll all the drives—called Agents.

## Enroll the Tape Drives

### For the service representative:

1. After the drive reboots, on the VOP main screen:

- Take the drive offline.
- Pull down the Configure menu.
- Select Drive Data.

The Configure Drive Parameters screen appears (notice the License button is gone).

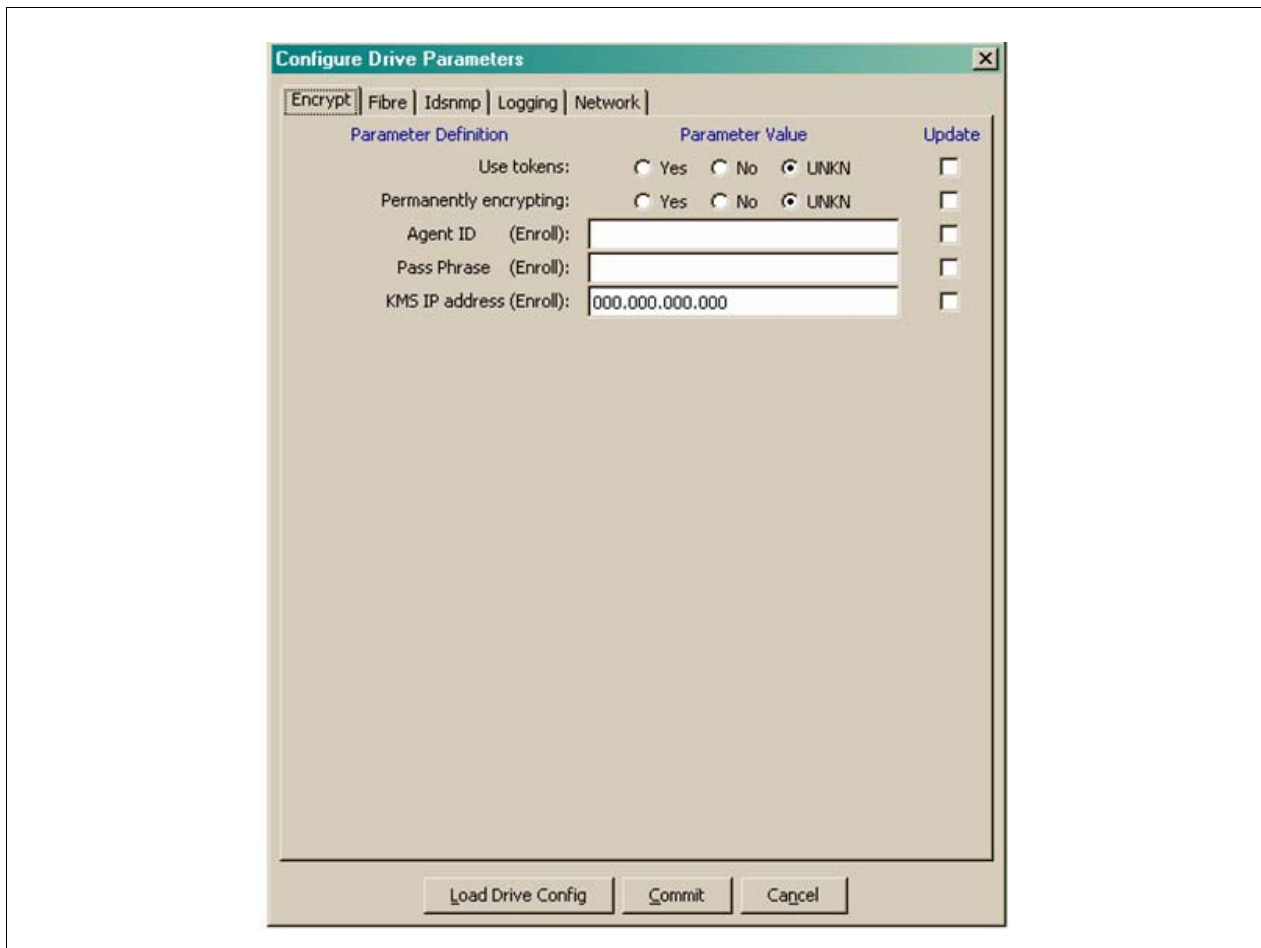

### For the customer:

2. Select if this drive is going to use tokens:

Yes , using tokens (KMS Version 1.x)

No , not using tokens (KMA Version 2.x)

3. Select if this drive is going a permanently encrypting tape drive:

Yes , permanent

No , switchable

4. Enter both the:

Agent ID:

Pass Phrase:

KMS IP address of the appliance:

5. Click on the Commit button. The tape drive will reboot.

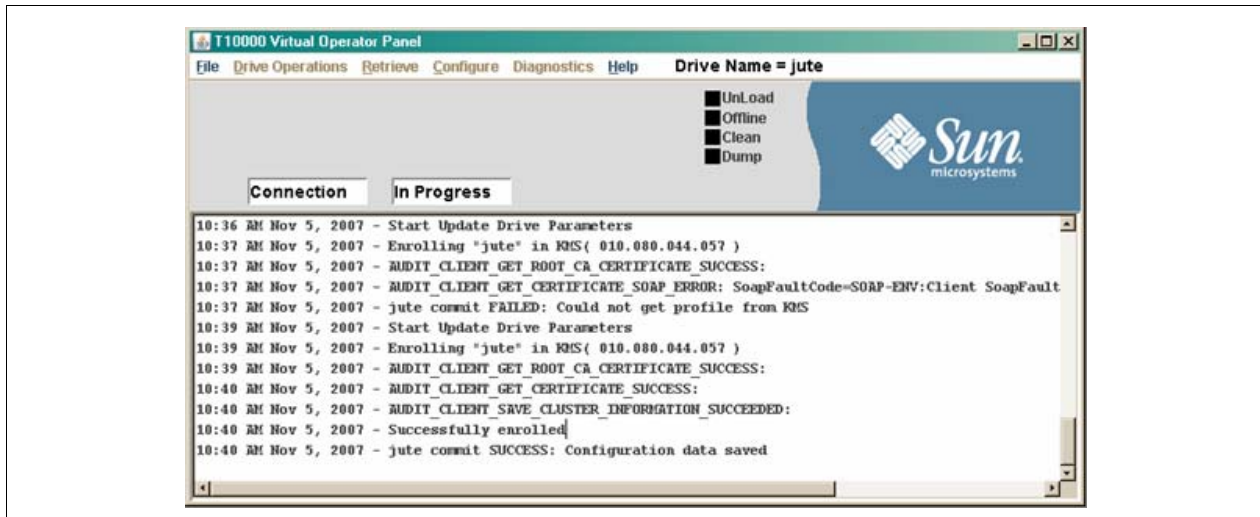

The Configuration menu Drive Settings screen shows the drive is licensed, enrolled, and needs media keys.

Manufacturing	Missing	Network	Rfid	Statistics	Version
Encrypt	Fibre	Idsnmp	Keyid	Logging	
<b>Parameter Definition</b>		<b>Parameter Value</b>			
Crypto Serial Number:		000000f2			
Device zeroed:		No			
Device reset:		No			
Encryption active:		Yes			
Licensed:		Yes			
Use tokens:		No			
Permanently encrypting:		No			
Agent ID (Enroll):		"jute"			
KMS IP address (Enroll):		010.080.044.057			
Active media keys:		No			
Key Load Number:		0			
Number of media keys:		0			
Need media keys:		Yes			
Rcvd media keys:		No			

Crypto Serial Number (CSN)

Encryption active = Yes  
 Licensed = Yes  
 Use tokens = No  
 Permanently encrypting = no (switchable)  
 Agent ID = jute  
 KMA IP address: 10.80.44.57  
 Needs keys

The VOP main screen now shows that the drive is Online and that the Media will be encrypted (Red LED by the Media icon).

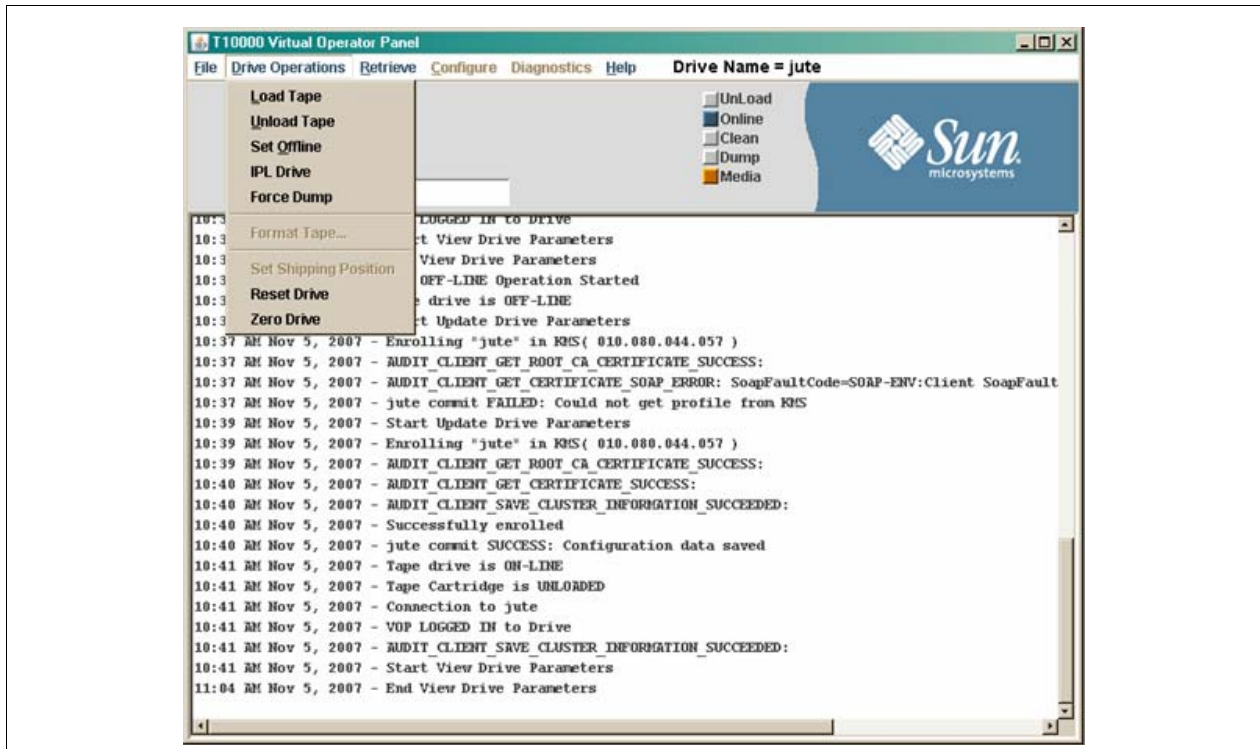

6. In the KMS Manager, assign the tape drives (agents) to the Key Groups.

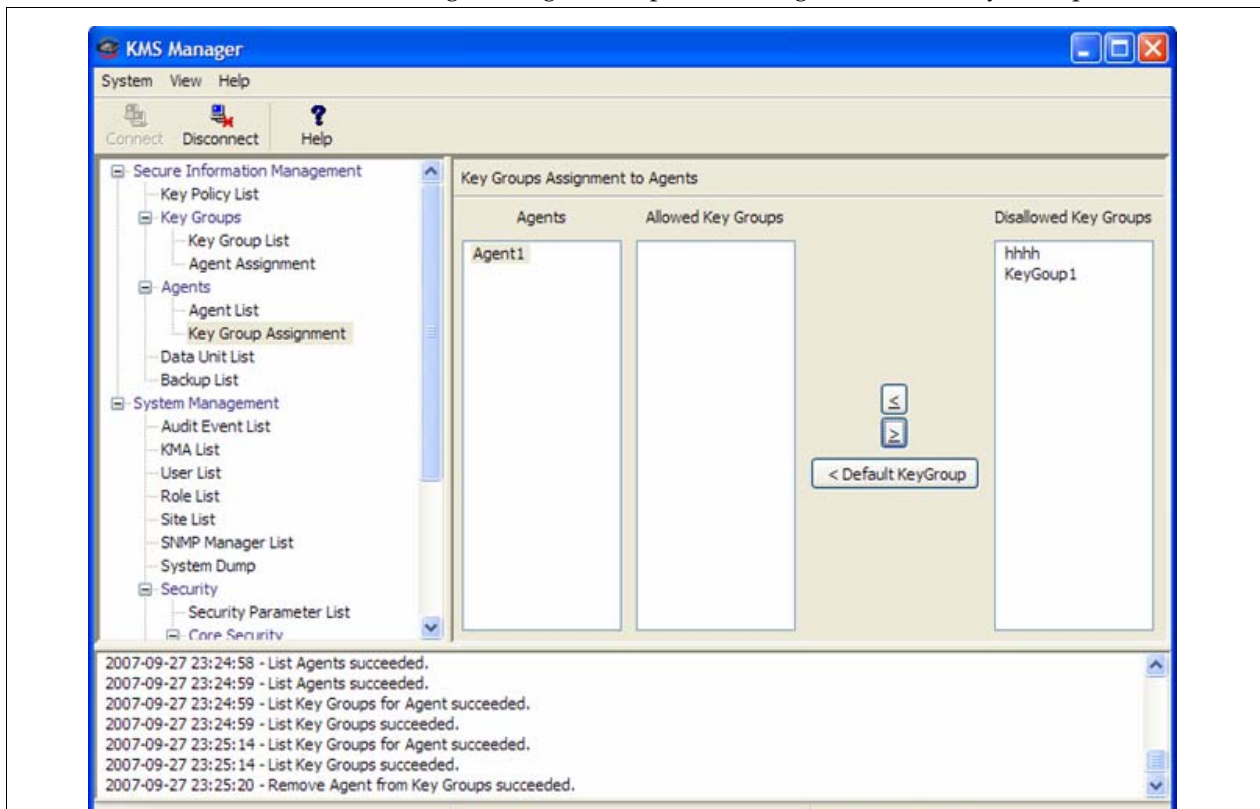



## Encryption Hardware Kits

---

This chapter contains information and instructions for the additional hardware kits.



For specific instructions about how to install the selected configuration, refer to:

<i>T10000 Tape Drive Installation Manual</i>	StorageTek: 96173
<i>SL8500 Modular Library System Installation Manual</i>	StorageTek: 96138
<i>SL3000 Modular Library System Installation Manual</i>	StorageTek: 316194201
<i>SL500 Modular Library System Installation Manual</i>	StorageTek: 96114
<i>L700/1400 Library Installation Manual</i>	StorageTek: 95843
<i>L180 Library Installation Manual</i>	StorageTek: 95896
<i>9310 PowderHorn Library Installation Manual</i>	StorageTek: 9314

If the manuals are not on hand, go to the Product Documentation Web site at:  
<http://docs.sun.com/app/docs>

The information in this chapter includes:

- “SL8500 Library” on page 46
- “External Rack Installations” on page 50
- “SL3000 Library” on page 51
- “SL500 Library” on page 52
- “9310 Library and 9741e Drive Cabinet” on page 53
- “L-Series Libraries” on page 56
- “Rackmount” on page 59

---

## SL8500 Library

Encryption-capable tape drives adds another element to the design for content management in an SL8500 library installation. Some considerations include:

- You may need to order multiple kits or additional Ethernet switches to support all of the encryption-capable tape drives in an SL8500 library or a library complex.
  - A single SL8500 library can support up to 64 tape drives in 4 groups of 16 drives.
  - An SL8500 Library Complex with multiple libraries joined together using pass-thru-ports can have a capacity of several hundred tape drives.
- The SL8500 can provide AC and DC power redundancy with the proper features.
- The SL8500 library contains internal accessory racks to install the key management appliances (KMAs) and additional hardware. These racks are an optional feature, and if the customer wants power redundancy, a minimum of two racks is required.
- The SL8500 supports all versions of the encryption-capable tape drives within the same library or library complex.
- The SL8500 supports partitioning, with up to four partitions using rail boundaries.
- The SL8500 supports multiple operating systems with multiple host connections.

See [FIGURE 4-2 on page 47](#) as an example.

This section contains information to install the encryption hardware in an SL8500 library.

**FIGURE 4-1** SL8500 Accessory Rack Guidelines



The SL8500 library encryption hardware kit is: **CRYPTO-2X-SL8500-Z**  
Verify that all components are available.

**Note** – For power redundancy, APC Switches PN: XSL8500-AC-SW-Z are required. Make sure these are available if the customer has ordered the power redundancy feature.

Also, if installing this in the internal racks, a 2N power configuration is required.



FIGURE 4-2 SL8500 Capabilities with Encryption

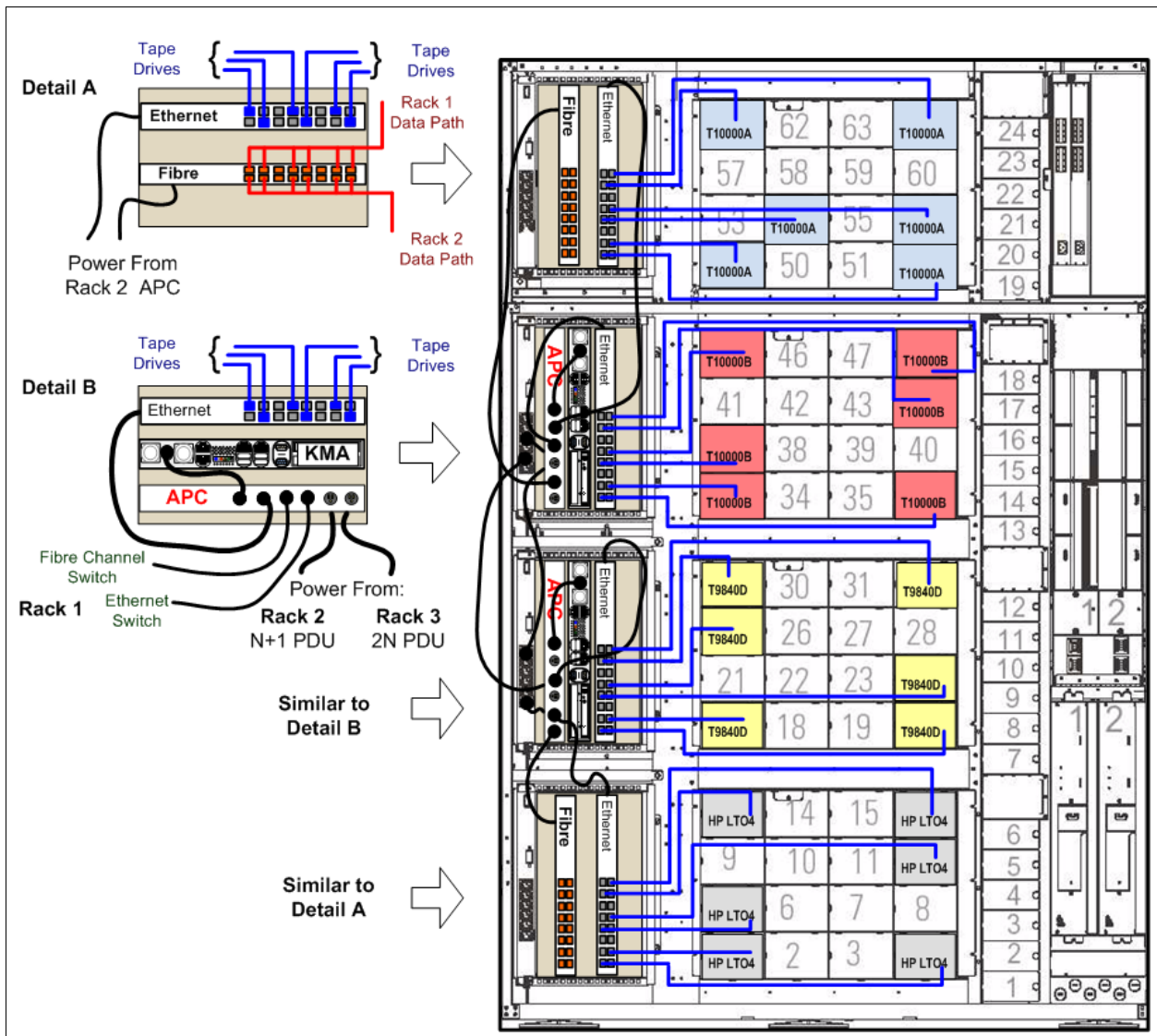

This example shows an SL8500 library with:

- 4 internal accessory racks installed
- 2N power for both AC and DC redundancy
- 4 partitions using rail boundaries

- Encryption Tape Drives:
  - T10000 models A and B
  - T9840D
  - HP LTO4

- Racks 2 and 3 contain:
  - 2 KMAs (encryption appliances)
  - 2 APCs (power distribution units)
  - 2 Ethernet switches (encryption and SDP)

- Racks 1 and 4 contain:
  - 2 Ethernet switches (encryption and SDP)
  - 2 Fibre Channel switches for the Data Paths to the tape drives (cabling not shown)

Notes:

APC = American Power Conversion.

PDU = power distribution units.

To show the connections, cable routing is exaggerated.

Tape drive interfaces are fiber-optic (Fibre Channel, 2 Gb and 4 Gb rates).

## SL8500 Accessory Racks

The SL8500 library provides space where up to four standard RETMA<sup>1</sup> 19-inch racks can be installed. These racks are oriented so the components mount *vertically* instead of horizontally. Each rack can hold up to 6 units—called Us<sup>2</sup>—of equipment, such as the key management appliances and the 24-port Ethernet switches.

Each rack has a six-connector power distribution unit (PDU) that provides AC power, and two cooling fans that provides additional air flow, for the equipment in the rack. Because of the numerous types of equipment, Sun StorageTek cannot mandate what the customer installs in these racks; therefore, certain guidelines should be followed. [Table 4-1](#) lists these guidelines.

**TABLE 4-1** SL8500 Accessory Rack Guidelines

Guideline	Descriptions
Rack numbering	Rack numbering is top-down from 1 to 4. Rack 1 is on the top; Rack 4 is on the bottom.
Rack mounting	Components must be able to function in a vertical orientation. Heavy components (such as Fibre Channel switches) must have threaded holes in the sides to attach rack slides. Light weight components (such as the Ethernet switches) may be mounted with a bracket.
Dimensional restrictions	Rack module depth is 72 cm (28 in.). Recommended safe length is 66 cm (26 in.).
Equipment weight	The accessory rack itself is mounted on slides rated for 80 kg (175 lb). The recommended safe load is 64 kg (140 lb). <b>The KMA is 10.7 kg (23.45 lb), the Ethernet switch is 1.5 kg (3.1 lb)</b>
Power consumption	Per rack module is 4 Amps (maximum). Per outlet strip is 200–240 VAC, 50 to 60 Hz. <b>The KMA is 185 W, the Ethernet Switch is 20 W.</b>
Power cord	Power plug to connect to the rack PDU is: IEC320 C13 shrouded male plug. Minimum cord length is component <i>plus</i> 46 cm (18 in.) for a service loop.
Thermal requirements	Maximum power dissipation is 880 watts (3,000 Btu/hr) per rack module.
Air flow	Generally from non-port end to port end of component. Maximum volume per 6U rack module is 241 scfm (standard cubic feet per minute) at 0 inches of water static pressure to a minimum of 0 scfm at 0.60 inches of water static pressure depending upon the devices and equipment installed blocking the fan air flow.
Regulatory compliance	Minimum requirements are: Safety—UL or CSA certification and Electromagnetic—Class A certification from agencies such as FCC or BSMI.

### Important:

When planning to install encryption hardware in an accessory rack, remember:

- Two of the racks (2 and 4) receive power from the primary N+1 AC power grid.
- The other two racks (1 and 3) *require* the 2N power configuration.

1. RETMA = Radio Electronics Television Manufacturers Association.

2. U stands for rack units. One unit is equal to 4.4 cm (1.75 in.).

## Encryption Hardware

To install the encryption hardware in an accessory rack:

1. Attach the mounting brackets to the KMAs and Ethernet switches. Hardware is provided with each unit and in the hardware kit.
2. Install the rack module rails and slides.
3. Install the:
  - Ethernet switch to the right of the bay, connections facing out
  - KMA to the left of the Ethernet switch, connections facing out
  - If installing power distribution units, place them next to the rack power units
4. Using [FIGURE 4-2 on page 47](#) as an example:
  - a. Connect the power cords.
 

**Important:** See [Chapter 2, “Key Management Appliances”](#) and [“Configure the ELOM IP Address” on page 8](#) **before** you plug power cables into the KMAs.
  - b. Connect the Ethernet cables from the dedicated customer network—with access to the Key Management System (KMS)—to each KMA and the Ethernet switches.
  - c. Connect the Ethernet cables from the switch to the tape drives.

## Drive Tray

The drive tray for the T10000 in an SL8500 library provides:

- Dual port interface connections
- Ethernet connection
- Drive status indicators:
  - Status (activity)
  - Maint (Maintenance switch)
  - **Crypt** (Encryption-capability)
  - PWR (Power)
  - Fault

**FIGURE 4-3** T10000 Drive Tray

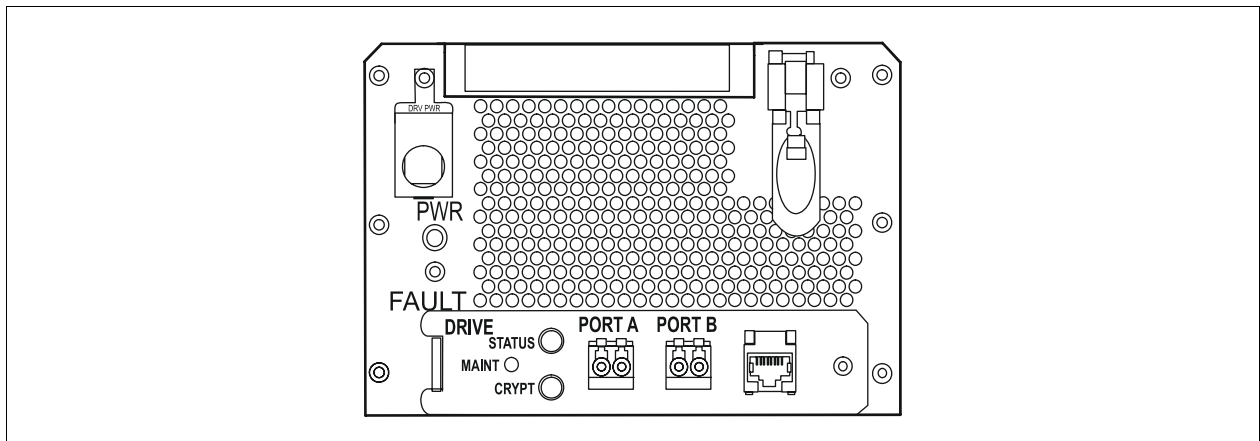

## External Rack Installations

**FIGURE 4-4** External Rack Installation

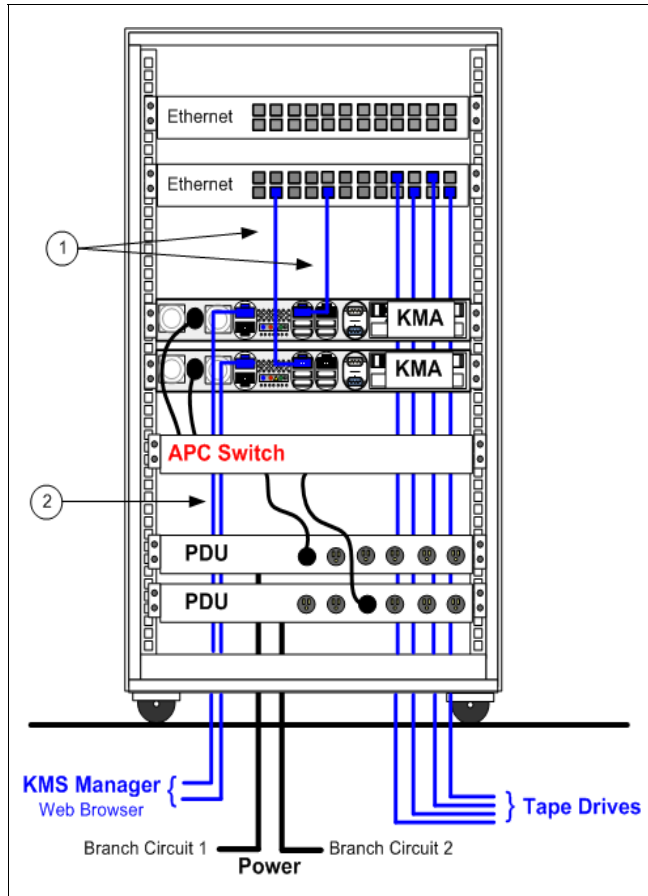

Because some configurations may have limited rack space, an external rack is available to install the encryption hardware.

**Note** – The 9310 / 9741e Drive Cabinets will require an external rack installation.

### Tape drives:

Depending on the number of tape drives, you may need more than one Ethernet switch. Each tape drive needs an Ethernet connection. More than one Ethernet switch can also be used to provide redundancy.

**Kit:** CRYPTO-20U-Z is a half-high rack. This external rack is:

- 20-units high (approximately 3 ft)
- 19-inches wide

### Power redundancy:

APC Switch PN: XSL8500-AC-SW-Z

### Callouts:

1. Service Network (KMA to drives)
2. KMS Manager and the Management Network

### To install the encryption hardware in an external rack:

1. Attach the mounting brackets to the KMAs, Ethernet switches, and PDUs. Hardware is provided with each unit and in the hardware kit.
2. Install the rack module rails and slides.
3. Install the equipment in this order:
  - PDU on the bottom of the rack.
  - KMAs above the PDUs.
  - Ethernet switch on the top of the rack.
4. Using [FIGURE 4-4](#) as an example, connect the following cables:
  - PDU power cords to the customer branch circuits (for redundancy).
  - Internal equipment power cords to the PDU.
  - Ethernet cables from the Management Network to the KMAs.
  - Ethernet cables from the KMAs to the switch. From the switch to the tape drives.

## SL3000 Library

This section contains information to install the encryption hardware in an SL3000 library.

**FIGURE 4-5** SL3000 Library



The SL3000 library maintains the fundamentals of a modular design using four types of modules; two of them that can have tape drives.

**TABLE 4-2** SL3000 Module Types

Module Type	Quantity Per Library	Capacity	
		Slots <sup>1</sup>	Tape Drives <sup>2</sup>
Base Module (required)	One only	205 or more	24
Drive Expansion Module (increases drive and cartridge capacity)	One only Left of Base	153 or more	32
Cartridge Expansion Module (increases cartridge capacity)	Variable	438 or more	—
Parking Expansion Module (dual-robotics requirement)	Two only (optional)	620 for both	—

1) Slots = Minimum capacity listed.  
2) Tape Drives = Maximum capacity listed. From 1 to 56.

There are elements that you need to consider to design for content management and encryption in an SL3000 library. Some considerations include:

- Because the SL3000 library has limited rack space, an external rack may be required to install the encryption hardware.
- The SL3000 supports all versions of the encryption-capable tape drives.
- The SL3000 supports partitioning.
- The SL3000 supports multiple operating systems with multiple host connections.

## SL500 Library

This section contains information to install the encryption hardware for an SL500 library.

**FIGURE 4-6** SL500 Library



The SL500 library is a rack-installed, modular design that consists of one *required* base module (shown above). To a total configuration of five modules, by adding up to four *optional* drive and cartridge expansion modules (shown to the right).

A customer configuration that includes an SL500 library plus the encryption hardware would be:

- One base module
- Up to three expansion modules
- Encryption hardware

If a fourth expansion module is installed, an external rack will be required for the encryption hardware.

There are elements that you need to consider to design for content management and encryption in an SL500 library. Some considerations include:

- Because the SL500 library is a rack-installed library, there may be limited space to install the additional hardware, an external rack may be required to install the encryption hardware.
- The SL500 supports:
  - Only LTO-type tape drives (HP LTO4 encryption-capable)
  - SCSI-direct attachments to the tape drives
  - From 1 to 18 tape drives
  - Partitioning
  - Open Systems platforms

The encryption hardware kits are:

- **CRYPTO-2X-SL500B-Z** (for the base module)
- **CRYPTO-2X-SL500X-Z** (one for each drive expansion module)

Verify that all components are available.

---

## 9310 Library and 9741e Drive Cabinet

The 9310—PowderHorn—automated cartridge system (ACS) is an enterprise-class library that offers up to 6,000 data cartridges. Each library storage module (LSM) can have up to four drive cabinets that contain up to 20 drives per cabinet (80 drives total).

This section contains information to install the encryption hardware in a 9741e Drive Cabinet for a 9310 library.

Because the 9310 library and the 9741e Drive Cabinet have no additional rack space, an external rack is required to install the encryption hardware. Use a customer provide rack or an external rack kit. See [“External Rack Installations”](#) on page 50.

**FIGURE 4-7** 9310–PowderHorn–Library



The encryption hardware kits are:

- **CRYPTO-2X-9310-Z** (for the first 9741e Drive Cabinet)
- **CRYPTO-2X-9741E-Z** (for each additional drive cabinet)

Verify that all components are available.

### External Rack Installation

The 9310 and 9741e Drive cabinet will require an external rack.

See [“External Rack Installations”](#) on page 50 for more information.

## Drive Cabinet Ethernet Switch

**FIGURE 4-8** Drive Cabinet Ethernet Switch Installation

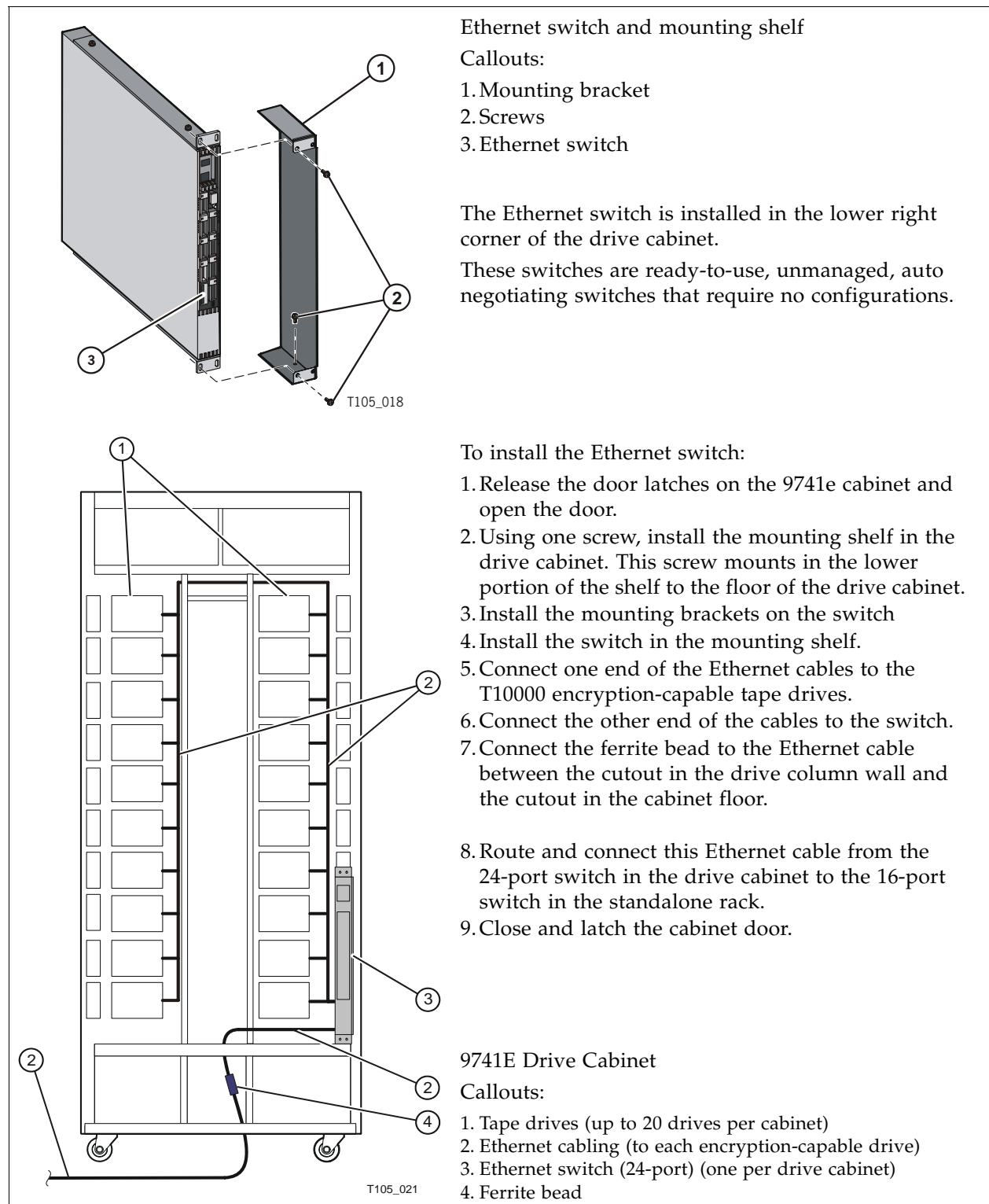



## Cable Routing

Route and connect one Ethernet cable from the 24-port switch in the drive cabinet to the 16-port switch in the standalone rack.

**FIGURE 4-9** External Rack and Ethernet Cabling

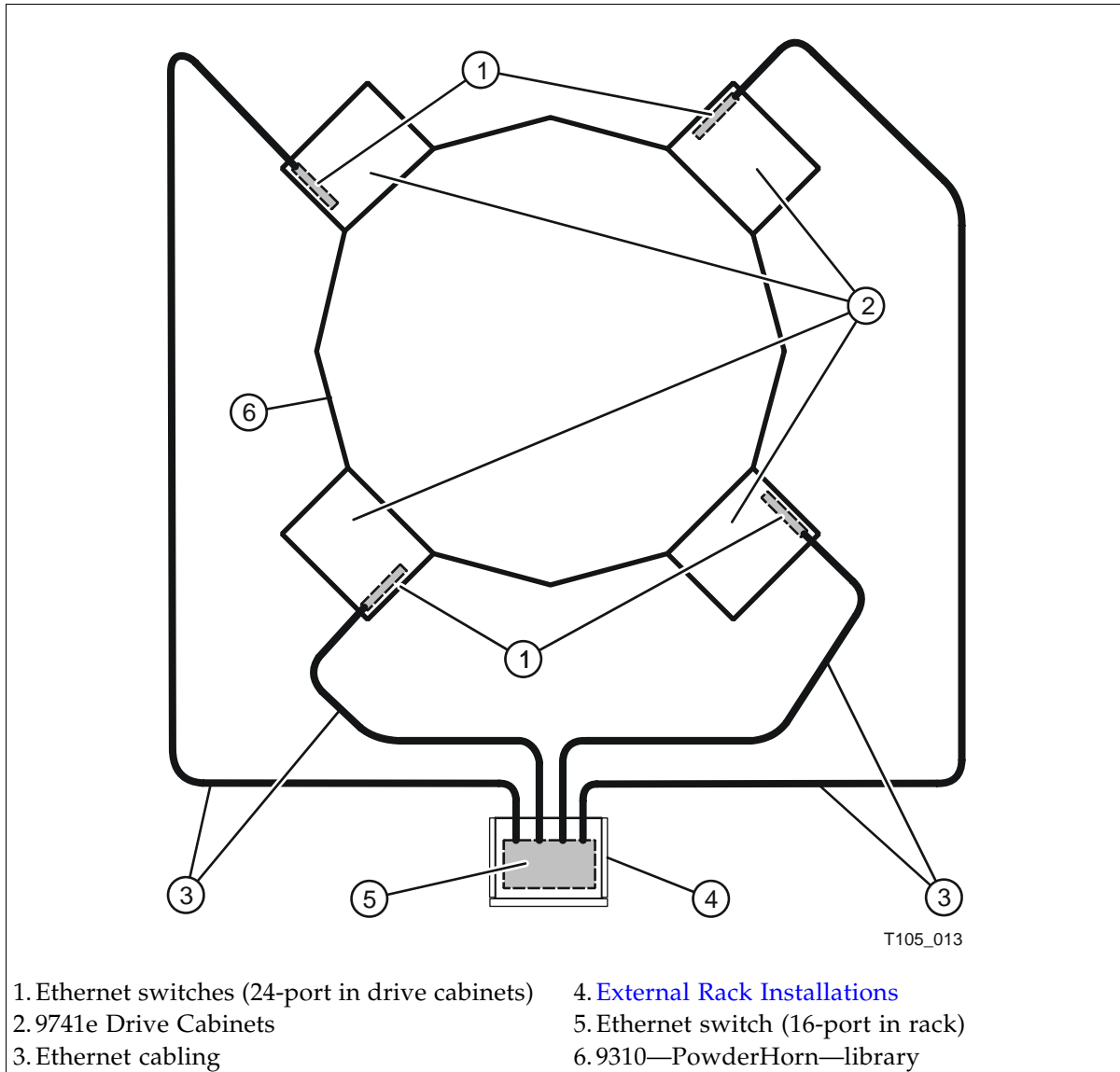

---

## L-Series Libraries

The Sun StorageTek L-Series libraries offer low-end, enterprise-class and mid-range, automated tape solutions that fit a variety of customer needs.

This section contains information to install the encryption hardware in an L-Series library.

**FIGURE 4-10** L-Series Libraries



The encryption hardware kit is:

- **CRYPTO-2X-L7/14-Z** (Ethernet switch and cables)

Verify that all components are available.

### L-Series Library Rack Space

The L-Series libraries come equipped with internal rack space that can be used to install the encryption hardware.

Cooling considerations should be made based upon the power dissipation within the rack space, as well as the external library room ambient conditions.

Additional cooling is recommended for high power dissipation components such as multi-processor servers; however, additional cooling it should not be required for the encryption hardware kits.

## L700/L1400 Library Encryption Hardware

The L700 and L1400 libraries have an internal, 13-unit, rack “area” accessible from behind the right front door or the left rear door of the library. The encryption hardware can be installed from either the front or the rear; however, a rear installation offers more space for cabling.

Rack area requirements:

- Total maximum weight in this location cannot exceed 136 kg (300 lb).
- Power cable space is provided in the cutout area of the rear door.
- Ventilation openings in the rear of the cabinet must have at least 100 mm (4 in.) clearance for proper air flow.

**FIGURE 4-11** L-Series Libraries

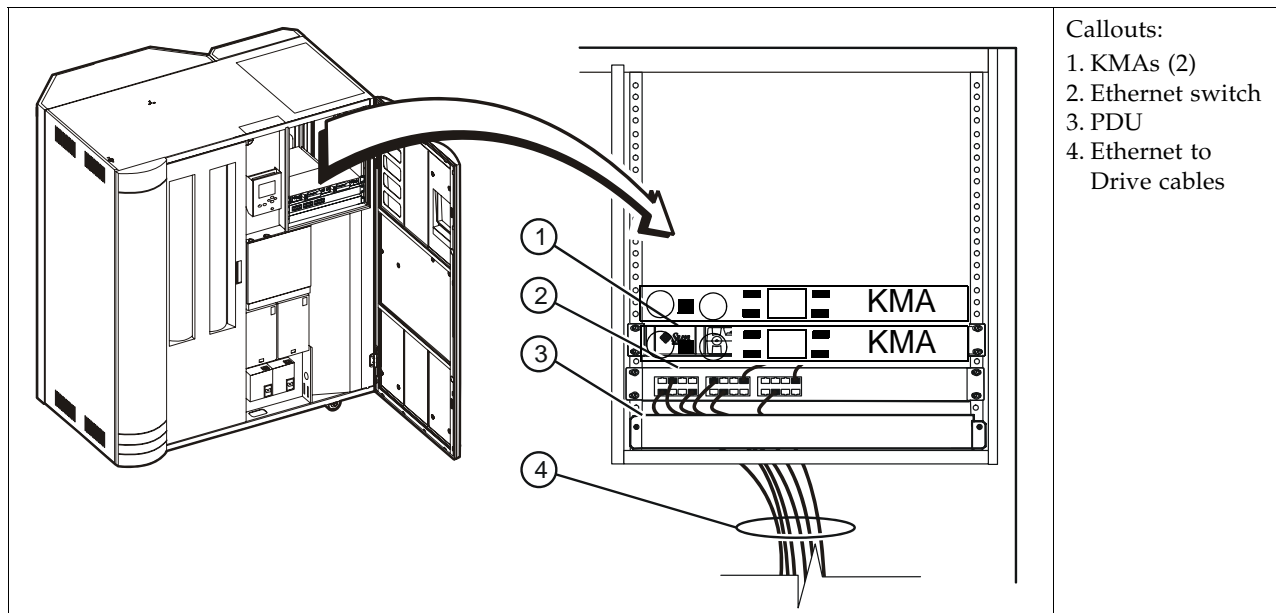

To install the encryption hardware in the L700/L1400 internal rack area:

1. Attach the mounting brackets to the KMAs, Ethernet switch, and PDU. Hardware is provided with each unit and in the hardware kit.
2. Install the rack module rails and slides.
3. Install the equipment in this order:
  - KMAs on top.
  - Ethernet switch above the PDUs.
  - PDU on the bottom of the rack area.
4. Connect the power cords.
 

**Important:** See [Chapter 2, “Key Management Appliances”](#) and [“Configure the ELOM IP Address” on page 8](#) before you plug power cables into the KMAs.
5. Connect the Ethernet cables from the dedicated customer network—with access to the Key Management System Manager—to each KMA and the Ethernet switch.
6. Connect the Ethernet cables from the switch to the tape drives.

**Note** – Because the Ethernet switch was previously installed in this configuration, the KMAs are installed above the switch.

## L180 Library Encryption Hardware

The L180 libraries have an internal, 6-unit, rack “area” accessible from behind the right front door of the library.

**FIGURE 4-12** L-Series Libraries

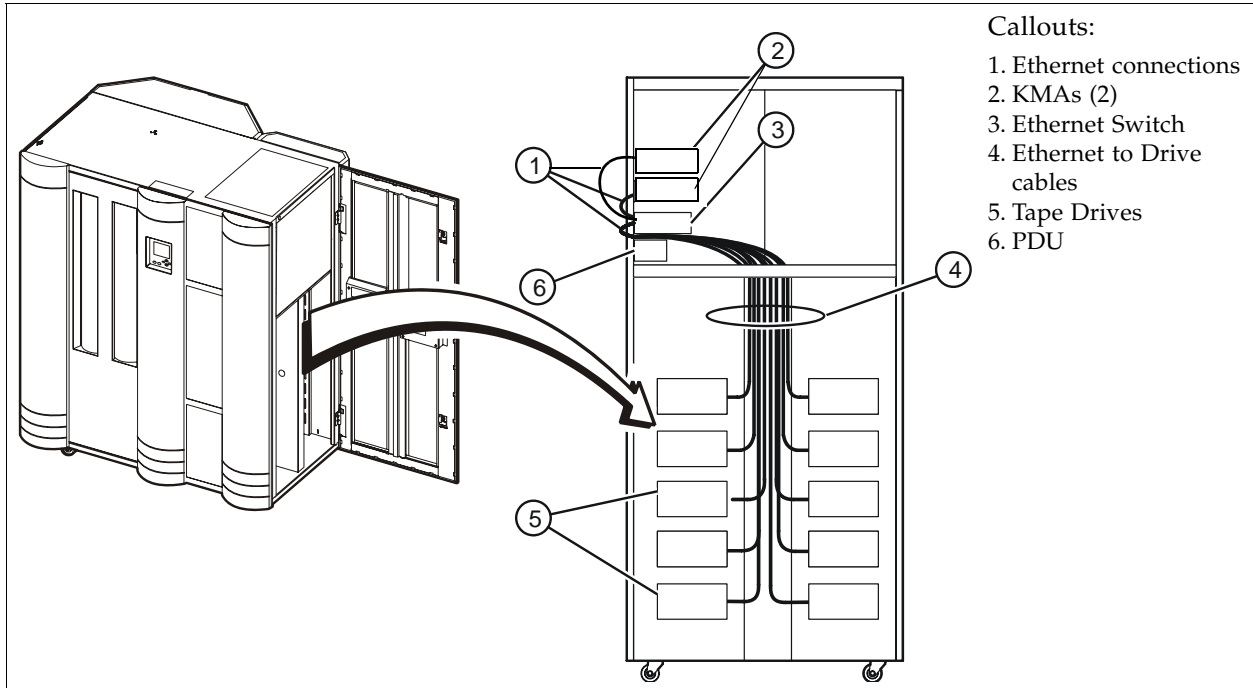

To install the encryption hardware in the L180 internal rack area:

1. Install the equipment in this order:
  - KMAs on top.
  - Ethernet switch above the PDUs.
  - PDU on the bottom of the rack area.
2. Connect the PDU power cables to the customer’s power source.
3. Connect the power cords.
 

**Important:** See [Chapter 2, “Key Management Appliances”](#) and [“Configure the ELOM IP Address” on page 8](#) before you plug power cables into the KMAs.
4. Connect an Ethernet cable from the dedicated customer network—with access to the KMS Manager—to each KMA and the Ethernet switch.
5. Connect the Ethernet cables between the switch and the tape drives.
6. Connect the Ethernet cables between the switch and the KMAs.

**Note** – Because the Ethernet switch was previously installed in this configuration, the KMAs are installed above the switch.

# Rackmount

This section contains information to install the encryption hardware for rack-mounted tape drives.

**FIGURE 4-13** Rackmount Assembly



The encryption hardware kits **CRYPTO-2X-RACK-Z** includes:

- Rack-mounting hardware
- Ethernet switch and cables

Verify that all components are available.

**To install the encryption hardware:**

**FIGURE 4-14** Rackmount Instructions

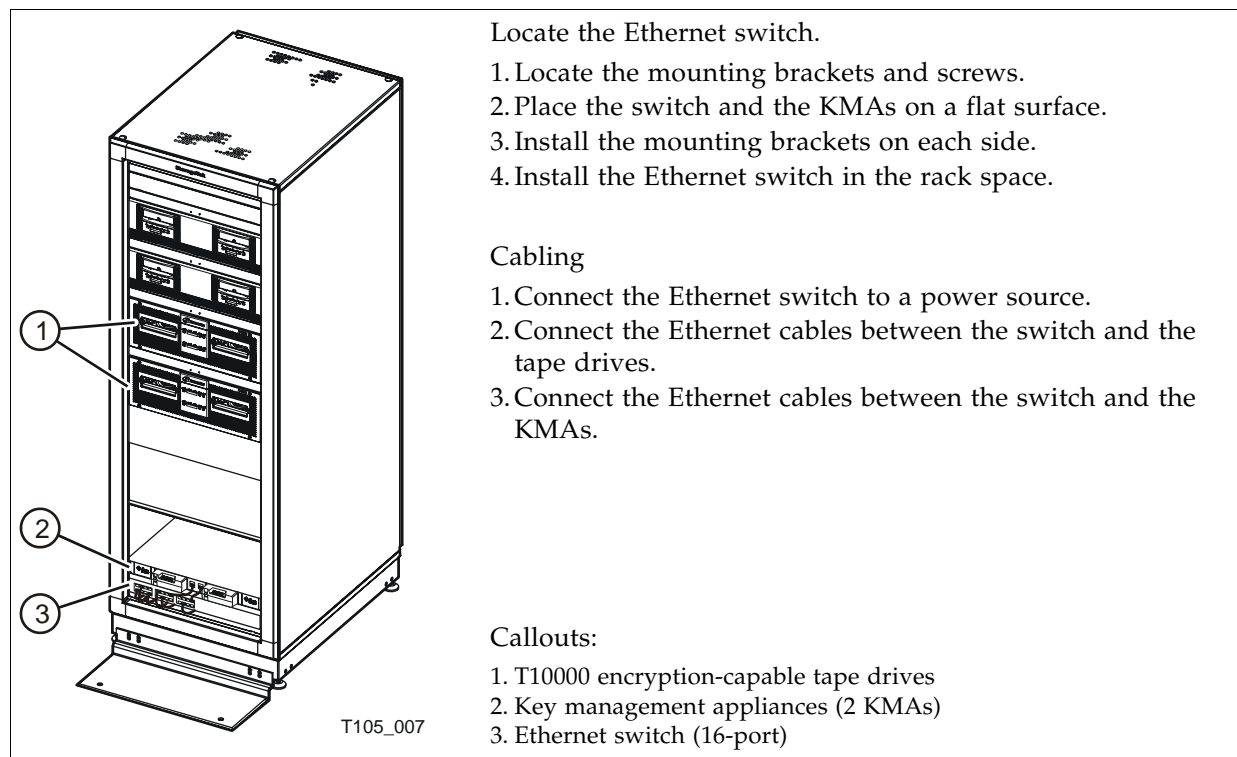

## Service Delivery Platform

The Service Delivery Platform (SDP) is a support solution for Sun StorageTek libraries and tape drives that consists of a smart appliance and dedicated network.

The Key Management Appliance includes a specific Ethernet connection (LAN 2 port) for connection to this network.

The SDP appliance uses the Dynamic Host Configuration Protocol (DHCP) to automate the assignment of IP addresses for device connections. When incorporating the KMAs into an SDP network, it is best to use the established addresses provided by the SDP; the IP address range is 172.18.18.xxx.

FIGURE 4-15 shows an example of an SDP network with connection to a KMA cluster.

**FIGURE 4-15** Systems Delivery Platform

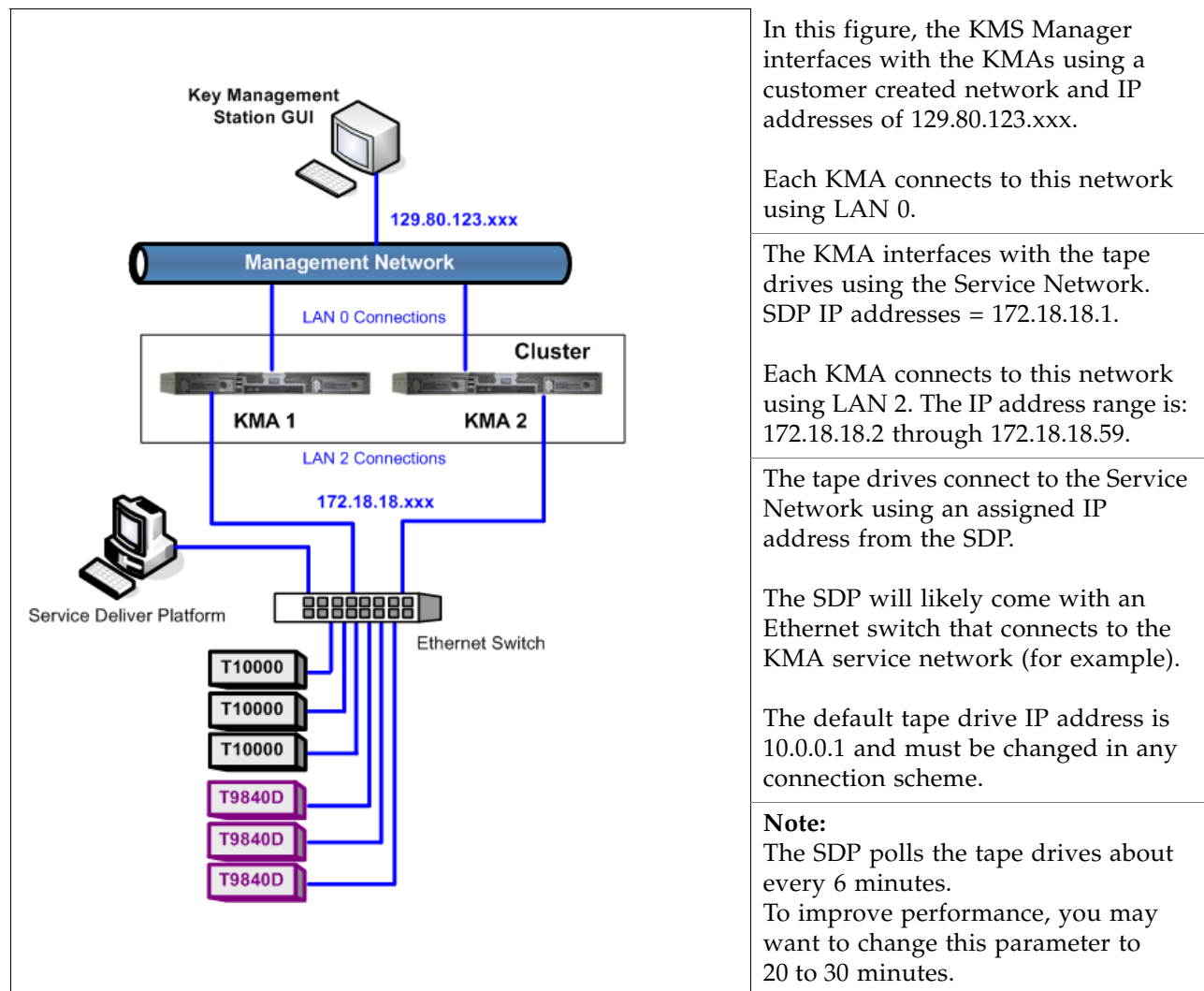

For more information, go to: <http://csa-wiki.central.sun.com/display/SDP>

## Service

---

This chapter describes the service tasks for the components in the Key Management System Version 2.0, which includes:

- [“Field Replaceable Units” on page 62](#)
- [“Obtaining Support” on page 64](#)
- [“System Upgrade” on page 67](#)
- [“Restore From Backup” on page 68](#)
- [“System Dump” on page 69](#)
- [“Tape Drives” on page 70](#)
- [“Switch Encryption On and Off” on page 71](#)
- [“KMS Version 1.x Support” on page 72](#)

## Field Replaceable Units

Currently, the only field replaceable units (FRUs) are the:

- **Key Management Appliance (KMA)** PN: #3154936-Z  
If the KMA fails, replace the entire server and for security reasons, scrap onsite.
- **Tape drive (Agents).**  
If a tape drive fails, replace the tape drive using the drive service manual.
- **Ethernet switch.**  
If an Ethernet switch fails, replace the switch.

**TABLE 5-1** FRU Listing

Vendor	Part	Number	Description
Sun	KMA 2.0	#3154936-Z	CRYPTO-KMA-2-Z FRU, KEY MANAGEMENT APPLIANCE
3-Com	16-port Switch 3C16470	260800489	CRYPTO-X-16PT ETHERNET SWITCH, 16 Port, RJ-45, 10B-T/100B-TX
3-Com	24-port Switch 3C16471	0800492	CRYPTO-X-24PT ETHERNET SWITCH 24 Port, RJ-45, 10B-T/100B-TX

A Keyboard and Monitor is available and consists of these part numbers:

**TABLE 5-2** Keyboard Monitor Kit

315497101	Monitor/Keyboard, Rack Mount, US
315497201	Slide Kit, Monitor/Keyboard, Rack Mount
315497301	Cable, Monitor, Rack Mount
315497401	Cable, keyboard, rack mount



# Account Log

**TABLE 5-3** KMA Account Log

<b>Account Name:</b>			
<b>KMA</b>			
<b>Site Location:</b>	<b>KMA S/N:</b>	<b>KMA Name:</b>	<b>KMA Firmware Level:</b>
<b>KMA IP Address:</b>		<b>Service Network IP:</b>	
<b>KMS Manager IP:</b>		<b>ELOM IP:</b>	
<b>NTP   <input type="checkbox"/> Yes <input type="checkbox"/> No:</b>		<b>DHCP   <input type="checkbox"/> Yes <input type="checkbox"/> No:</b>	
<b>Gateway   <input type="checkbox"/> Yes <input type="checkbox"/> No:</b>		<b>DNS   <input type="checkbox"/> Yes <input type="checkbox"/> No:</b>	
<b>KMA Number:</b>		<b>Number of KMAs in Cluster:</b>	
<b>KMA Location:</b>			
<b>KMS Manager Location:</b>			
<b>Configuration Types:</b>	<input type="checkbox"/> SL8500 library <input type="checkbox"/> SL3000 library <input type="checkbox"/> SL500 library <input type="checkbox"/> 9310 library <input type="checkbox"/> L700/1400 library <input type="checkbox"/> L180 library	<b>Tape Drive Types:</b>	<input type="checkbox"/> T10000A tape drive <input type="checkbox"/> T10000B tape drive <input type="checkbox"/> T9840D tape drive <input type="checkbox"/> LTO4 tape drive
<b>Location:</b>		<b>Location:</b>	
<b>KMA</b>			
<b>Site Location:</b>	<b>KMA S/N:</b>	<b>KMA Name:</b>	<b>KMA Firmware Level:</b>
<b>KMA IP Address:</b>		<b>Service Network IP:</b>	
<b>KMS Manager IP:</b>		<b>ELOM IP:</b>	
<b>NTP   <input type="checkbox"/> Yes <input type="checkbox"/> No:</b>		<b>DHCP   <input type="checkbox"/> Yes <input type="checkbox"/> No:</b>	
<b>Gateway   <input type="checkbox"/> Yes <input type="checkbox"/> No:</b>		<b>DNS   <input type="checkbox"/> Yes <input type="checkbox"/> No:</b>	
<b>KMA Number:</b>		<b>Number of KMAs in Cluster:</b>	
<b>KMA Location:</b>			
<b>KMS Manager Location:</b>			
<b>Configuration Types:</b>	<input type="checkbox"/> SL8500 library <input type="checkbox"/> SL3000 library <input type="checkbox"/> SL500 library <input type="checkbox"/> 9310 library <input type="checkbox"/> L700/1400 library <input type="checkbox"/> L180 library	<b>Tape Drive Types:</b>	<input type="checkbox"/> T10000A tape drive <input type="checkbox"/> T10000B tape drive <input type="checkbox"/> T9840D tape drive <input type="checkbox"/> LTO4 tape drive
<b>Location:</b>		<b>Location:</b>	

## Obtaining Support

Technical support is available 24 hours a day, seven days a week and begins with a telephone call from you to Sun Microsystems StorageTek Support. You will receive immediate attention from qualified personnel, who record problem information and respond with the appropriate level of support.

To contact Sun Microsystems—StorageTek Support about a problem:

1. Use the telephone and call:
  - 800.525.0369 (inside the United States) or
  - Contact any of Sun's worldwide offices to discuss support solutions for your organization. You can find address and telephone number information at: <http://www.sun.com/worldwide/>
2. Describe the problem to the call taker. The call taker will ask several questions then:
  - Route your call to the appropriate level of support  
or
  - Dispatch a service representative.

If you have the following information when you place a service call, the process will be much easier. Complete as much information as possible—if known.

**TABLE 5-4** Obtaining Support

<b>Account name</b>			
<b>Site location number</b>			
<b>Contact name</b>			
<b>Telephone number</b>			
<b>Equipment model number</b>	<input type="checkbox"/> KMA (Appliance) <input type="checkbox"/> KMS Manager (GUI) <input type="checkbox"/> SL8500 library <input type="checkbox"/> SL3000 library	<input type="checkbox"/> SL500 library <input type="checkbox"/> 9310 library <input type="checkbox"/> L700/1400 library <input type="checkbox"/> L180 library	<input type="checkbox"/> T10000A tape drive <input type="checkbox"/> T10000B tape drive <input type="checkbox"/> T9840D tape drive <input type="checkbox"/> LTO4 tape drive <input type="checkbox"/> Network
<b>Device address</b>			
<b>Urgency of problem</b>			
<b>Fault symptom code (FSC) or Error Code</b>			
<b>Problem description</b>			

## Replacing or Adding a New KMA

- When replacing a replacement KMA (or adding another KMA to the cluster) some initial steps are required using the KMS Manager (GUI).
- Then, during the QuickStart program for the next KMA, select:
  - (2) Join Existing Cluster
- After that, the QuickStart program for the new KMA prompts for the Passphrase and IP address of that existing cluster.

### To replace or add a KMA:

1. Log in to the KMS manager.
2. Select: System Management ⇨ KMA List ⇨ Create button.  
The Create KMA dialog box is displayed, with the General tab active.
3. Complete the following parameters:
  - **KMA Name:** Type a value that uniquely identifies the KMA in a cluster. This value can be between 1 and 64 (inclusive) characters.
  - **Description Type:** A value that uniquely describes the KMA. This value can be between 1 and 64 (inclusive) characters.
  - **Site ID** Click the down-arrow and select the site to which the KMA belongs. This field is optional.
4. Open the Passphrase tab.
5. Enter the Passphrase and Confirm the Passphrase.  
Enter from 8 to 64 characters. The default value is 8 characters.  
The KMA record is added to the database and displayed in the KMA List screen.
6. You must now run the QuickStart program on the KMA you just created so that they can join the Cluster.  
See [“QuickStart Program” on page 13](#) for information. Remember to select Option 2 to Join an Existing Cluster.

The KMA being replaced or added checks the firmware version against the existing versions in the cluster.

If it is not compatible, the new KMA displays an error and gives the user the option of upgrading or downgrading.

**FIGURE 5-1** KMA Replacement—Joining a Existing Cluster

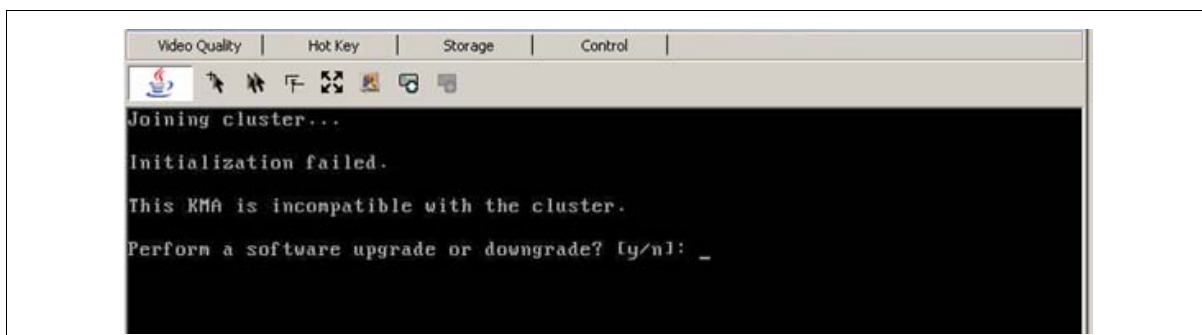

7. If the user selects “Yes”, then the KMA being added:
  - Grabs the code from the existing KMA in the cluster,
  - Downloads the code for its own, and
  - Installs the code.

This process takes about 25 to 30 minutes to complete.

**FIGURE 5-2** KMA Replacement—Joining a Existing Cluster

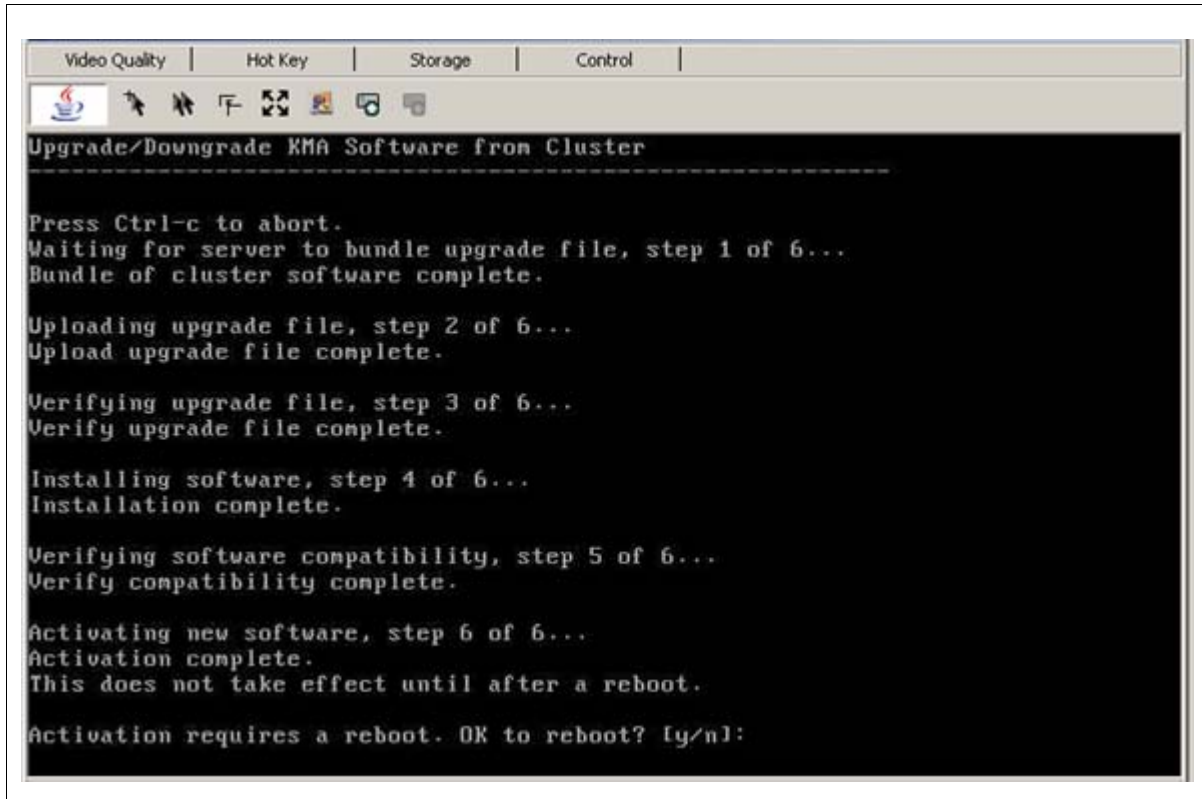

8. Once this process completes, the User needs to reboot the KMA.
9. After the KMA comes back online from the reboot, you need to continue with the QuickStart program.
10. Check that the new KMA is in service, select: System Management ⇔ KMA List.

# System Upgrade

To upgrade the KMA firmware, refer to the *KMS Administrator Guide* and:

1. Download the new firmware from (location not determined yet) onto a laptop.  
Refer to the instructions or Release Notes that come with the new firmware.
2. From the KMS Manager GUI, select:  
System Management ⇨ Local Configuration ⇨ Software Upgrade.

**FIGURE 5-3** System Upgrade

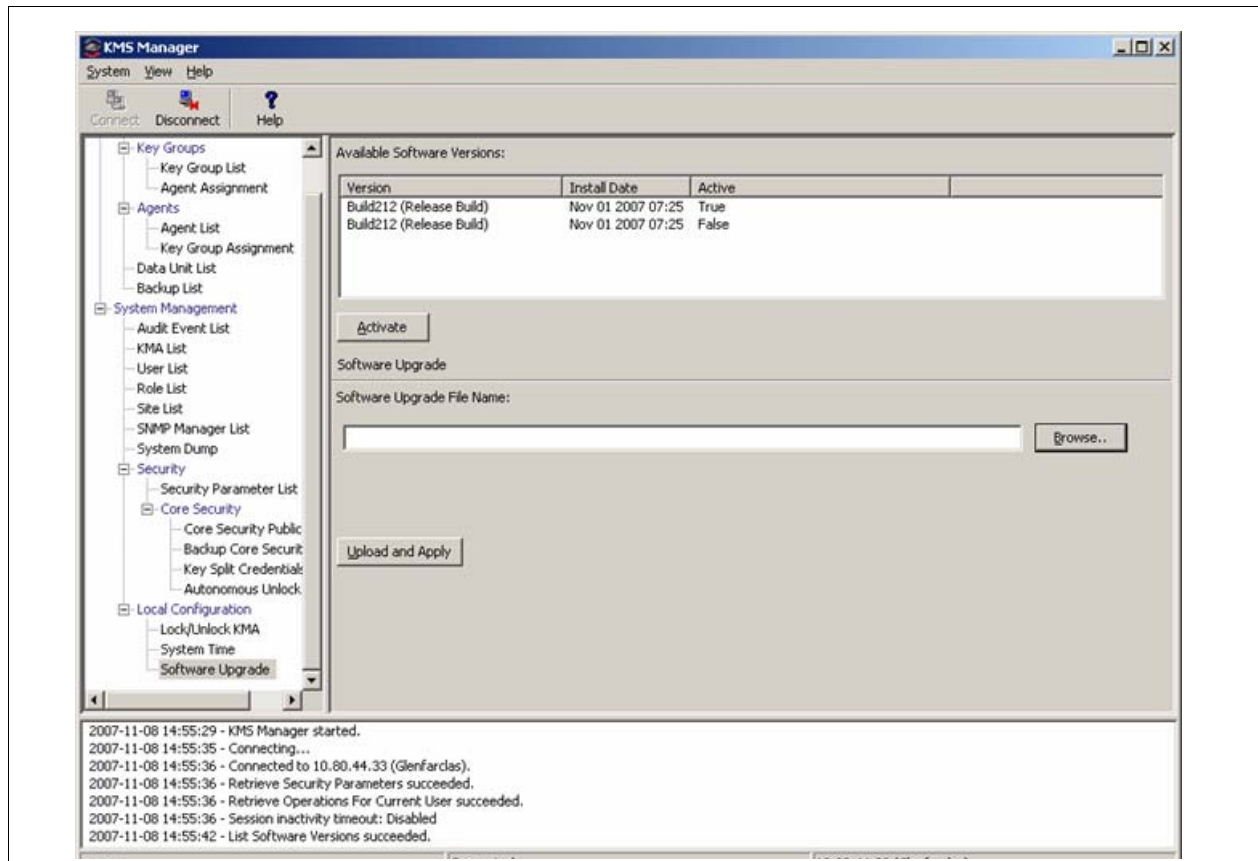

3. Click the Browse button to bring up a Choose File dialog.
4. Navigate to the new file, select it, and click OK.
5. Click the Upload and Apply button.  
This begins the upload process. When the upload and apply is complete, the new version will show up in the version list.
6. Select the new version and click the Activate button.  
The system will now reboot and start the new version.

**Note** – Most upgrades are going to require a new version of the KMS Manager GUI. Download and install the new GUI version.

You will need to reconnect to the system using the new version of the GUI.

---

## Restore From Backup



Restoring the system from a backup requires the use of a quorum.

Make sure the required number of users are available. The quorum must enter their user names and passphrases to authenticate the operation.

**Note** – Backup files are created and restored on the KMA.

To restore the system from a backup, refer to the *KMS Administrator Guide* and:

1. Select: Secure Information Management ⇄ Backup List.  
This allows you to view the history and details of the backup files.  
To identify the restore you want to use, double-click the Backup entry.  
The Backup Details dialog box is displayed for review.
2. From the Backup List screen, highlight the Backup you want to restore from.
3. Click on the Restore button. The Restore Backup dialog box is displayed.

**FIGURE 5-4** Restore Backup

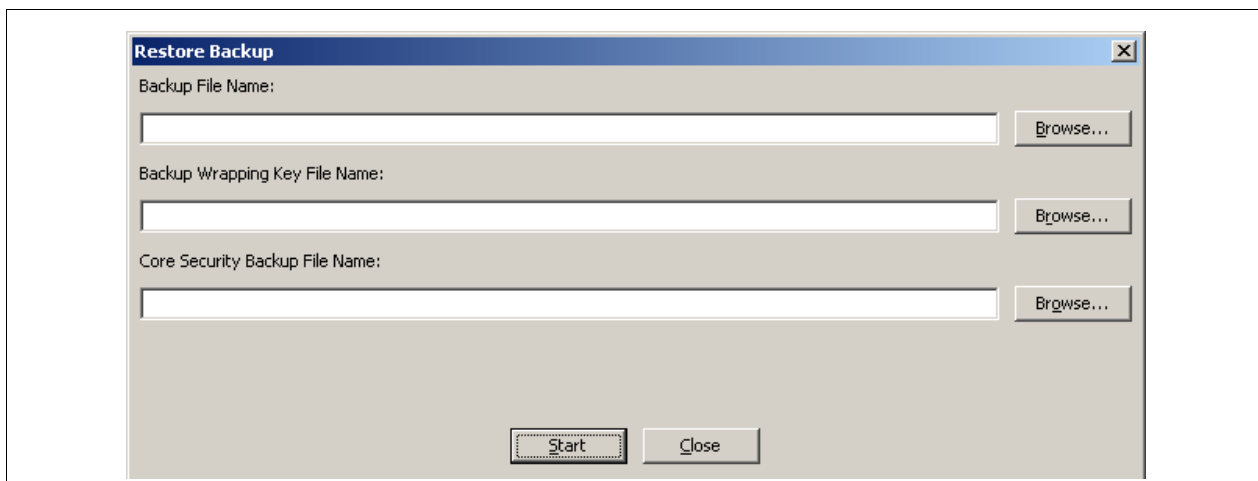

4. Click on the Start button.  
When the upload completes, the Key Split Quorum Authentication dialog box appears. The quorum must type their user names and passphrases to authenticate the operation.
5. Click on the OK button.  
A progress display of the restore is indicated.

# System Dump

A system dump is a user-invoke operation that results in a snapshot of all relevant data collected into a single file. You may be asked to provide a system dump to aide engineering in the analysis of a problem.

**Note** – A system dump does not contain any keys or key material.

To obtain a system dump:

1. From the KMS Manager GUI, select:  
System Management ⇄ System Dump.
2. Provide a system dump file location and name.
3. Click on the Start button.

**FIGURE 5-5** System Dump

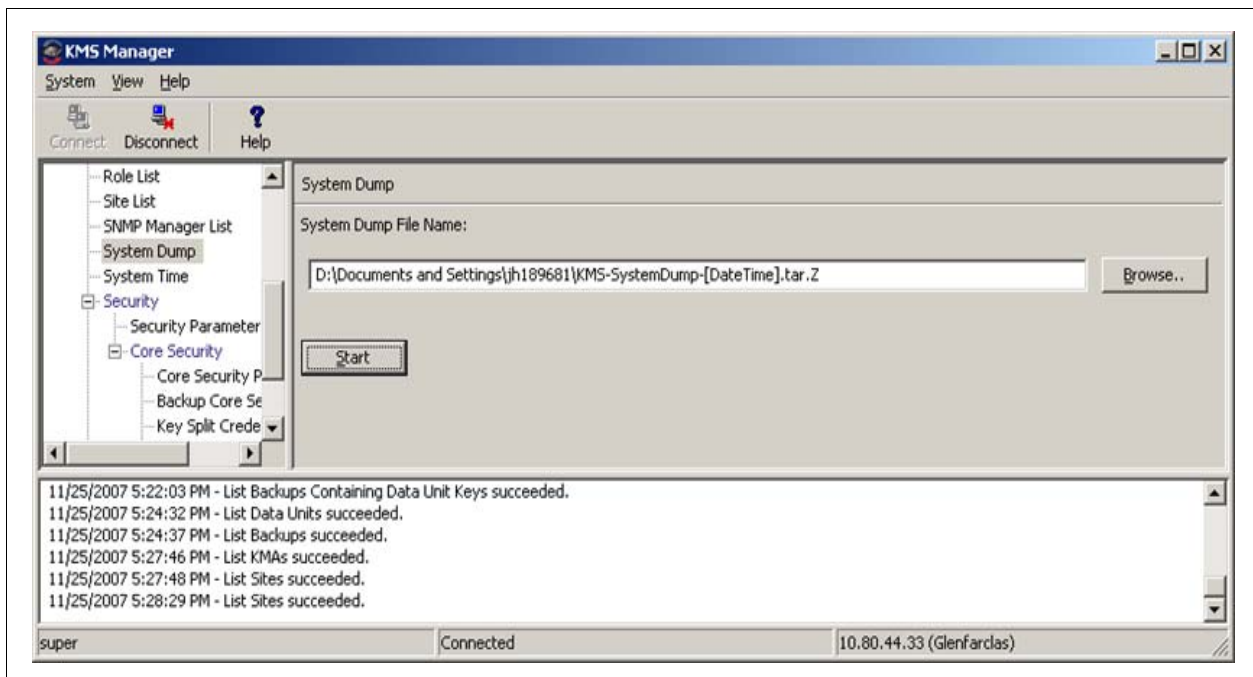

---

## Tape Drives



For specific information about how to service the tape drives, refer to:

<i>T10000 Tape Drive Installation Manual</i>	StorageTek: 96173
<i>T10000 Service Manual</i>	StorageTek: 96175
<i>Virtual Operator Panel—Service</i>	StorageTek: 96180
<i>Virtual Operator Panel—Customer</i>	StorageTek: 96179
<i>T9x40 Tape Drive Installation Manual</i>	StorageTek: 95879
<i>T9x40 Service Manual</i>	StorageTek: 95740
<i>HP LTO4 Documentation</i>	HP Online Site

If the manuals are not on hand, go to the StorageTek Customer Resource Center (CRC).



## Switch Encryption On and Off

With Version 2.0, the customer is capable of selecting which version and configuration, to permanently encrypt or not, and to switch encryption on and off per tape drive.

During tape drive enrollment, the customer can choose if they want the tape drives to have the capability of switching between encryption-capable and non-encryption.

If the customer selected “No” for Permanently Encrypting, they can switch the tape drives to non-encryption at a later date.

This is very beneficial and extremely cost-effective for disaster recovery sites that provide their customers with a choice of encryption and non-encryption.

To turn encryption off:

**FIGURE 5-6** Switch Encryption On and Off

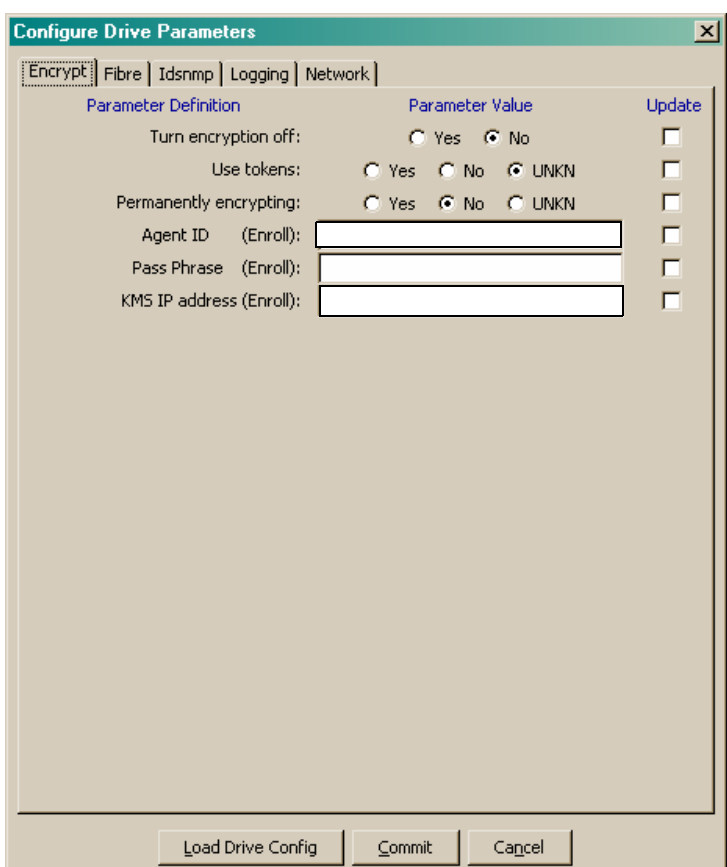

1. Using the Virtual Operator Panel, connect to the desired tape drive.
2. Select: Drive Operations ⇄ Reset Drive. Reply “Yes” to the Are You Sure? dialog box.  
The drive must be in the RESET state to turn encryption off.
3. For the **Turn encryption off:** Parameter Value, click “Yes.”
4. Click Commit.

The tape drive will reboot and be non-encrypting.

You can turn encryption back on from the Configuration menu.

## KMS Version 1.x Support

With Version 2.0, the customer is capable of selecting which version of the KMS to support—Version 2.0 or Version 1.x.

During tape drive enrollment, the customer can choose if they want the tape drives to support KMS Version 1.x and the use of Tokens to transfer the encryption keys.

**FIGURE 5-7** Switch Encryption On and Off

Parameter Definition	Parameter Value	Update
Use tokens:	<input type="radio"/> Yes <input type="radio"/> No <input checked="" type="radio"/> UNKN	<input type="checkbox"/>
Permanently encrypting:	<input type="radio"/> Yes <input type="radio"/> No <input checked="" type="radio"/> UNKN	<input type="checkbox"/>
Agent ID (Enroll):	<input type="text"/>	<input type="checkbox"/>
Pass Phrase (Enroll):	<input type="text"/>	<input type="checkbox"/>
KMS IP address (Enroll):	000.000.000.000	<input type="checkbox"/>

1. Using the Virtual Operator Panel, connect to the desired tape drive.
2. Select: Configure ⇌ Drive Data.
3. For the **Use tokens:** Parameter Value, click "Yes."
4. Click Commit.

## Work Sheets

---

The following pages contain work sheets that can help prepare for the installation of a Sun StorageTek encryption solution.

These work sheets include:

- [“Obtaining Support” on page 74](#)
- [“Initial Configuration Work Sheet” on page 75](#)
- [“User Roles Work Sheet” on page 76](#)
- [“Tape Drives Work Sheet” on page 77](#)
- [“Drive Enrollment Work Sheet” on page 78](#)

Make copies as necessary.

## Obtaining Support

Technical support is available 24 hours a day, seven days a week and begins with a telephone call from you to Sun Microsystems StorageTek Support. You will receive immediate attention from qualified personnel, who record problem information and respond with the appropriate level of support.

To contact Sun Microsystems—StorageTek Support about a problem:

1. Use the telephone and call:
  - 800.525.0369 (inside the United States) or
  - Contact any of Sun's worldwide offices to discuss support solutions for your organization. You can find address and telephone number information at: <http://www.sun.com/worldwide/>
2. Describe the problem to the call taker. The call taker will ask several questions then:
  - Route your call to the appropriate level of support  
or
  - Dispatch a service representative.

If you have the following information when you place a service call, the process will be much easier. Complete as much information as possible—if known.

**TABLE 0-1** Obtaining Support

<b>Account name</b>			
<b>Site location number</b>			
<b>Contact name</b>			
<b>Telephone number</b>			
<b>Equipment model number</b>	<input type="checkbox"/> KMA (Appliance) <input type="checkbox"/> KMS Manager (GUI) <input type="checkbox"/> SL8500 library <input type="checkbox"/> SL3000 library	<input type="checkbox"/> SL500 library <input type="checkbox"/> 9310 library <input type="checkbox"/> L700/1400 library <input type="checkbox"/> L180 library	<input type="checkbox"/> T10000A tape drive <input type="checkbox"/> T10000B tape drive <input type="checkbox"/> T9840D tape drive <input type="checkbox"/> LTO4 tape drive <input type="checkbox"/> Network
<b>Device address</b>			
<b>Urgency of problem</b>			
<b>Fault symptom code (FSC) or Error Code</b>			
<b>Problem description</b>			

# Initial Configuration Work Sheet

**TABLE A-1** Initial Configuration Settings—Customer

	KMA _____			KMA _____		
	Hostname	IP Address / Netmask	DHCP?1	Hostname	IP Address / Netmask	DHCP?1
<b>LAN 0 = Management</b>			Yes <input type="checkbox"/> No <input type="checkbox"/>			Yes <input type="checkbox"/> No <input type="checkbox"/>
<b>LAN 1 = ELOM</b>			Yes <input type="checkbox"/> No <input type="checkbox"/>			Yes <input type="checkbox"/> No <input type="checkbox"/>
<b>LAN 2 = Service</b>			Yes <input type="checkbox"/> No <input type="checkbox"/>			Yes <input type="checkbox"/> No <input type="checkbox"/>
<b>LAN 3 = Reserved</b>						
<b>KMA Name</b>						
<b>Gateway</b>						
<b>DNS Server</b>	Hostname: IP address:			Hostname: IP address:		
<b>Security Officer</b>	Login: Passphrase:			Login: Passphrase:		
<b>Root account Passphrase</b>						
<b>ELOM Passphrase</b>						
<b>Key Split Credentials</b>						
<b>Autonomous Unlocking 2</b>						
<b>Keyboard Type</b>						
<b>Note:</b>	1. Addresses assigned using DHCP <b>must be static</b> . The system cannot handle the DHCP server changing the IP addresses once assigned. 2. Autonomous Unlocking allows the KMA to enter a fully operational state after a hard or soft reset without requiring the entry of a quorum of passphrases using the KMS Manager. This information should not be written down and should be entered by the person to which they belong. These entries can be changed in the KMS Manager; so it may be desirable to enter something simple during the configuration, then change it later using the KMS GUI immediately after the KMA is configured.					



# Tape Drives Work Sheet

**TABLE A-3** Tape Drive Work Sheet—Service Representative

SDP IP Address:		File Pathname:		Location:
Serial Number / DMOD (Last 8 digits)	Drive Type	Crypto Serial Number (6 hexadecimal characters)	Drive IP Address	Location
1.				
2.				
3.				
4.				
5.				
6.				
7.				
8.				
9.				
10.				
11.				
12.				
13.				
14.				
15.				
16.				
17.				
18.				
19.				
20.				

# Drive Enrollment Work Sheet

**TABLE A-4** Enrollment Data Work Sheet—Customer

KMA Hostname:				KMA Hostname:			
KMA IP Address:				KMA IP Address:			
Drive Address	Drive Type	Drive IP Address	Agent ID	Passphrase	Tokens? (KMS 1.x)	Permanent?	
1.					Yes <input type="checkbox"/> No <input type="checkbox"/>	Yes <input type="checkbox"/> No <input type="checkbox"/>	
2.					Yes <input type="checkbox"/> No <input type="checkbox"/>	Yes <input type="checkbox"/> No <input type="checkbox"/>	
3.					Yes <input type="checkbox"/> No <input type="checkbox"/>	Yes <input type="checkbox"/> No <input type="checkbox"/>	
4.					Yes <input type="checkbox"/> No <input type="checkbox"/>	Yes <input type="checkbox"/> No <input type="checkbox"/>	
5.					Yes <input type="checkbox"/> No <input type="checkbox"/>	Yes <input type="checkbox"/> No <input type="checkbox"/>	
6.					Yes <input type="checkbox"/> No <input type="checkbox"/>	Yes <input type="checkbox"/> No <input type="checkbox"/>	
7.					Yes <input type="checkbox"/> No <input type="checkbox"/>	Yes <input type="checkbox"/> No <input type="checkbox"/>	
8.					Yes <input type="checkbox"/> No <input type="checkbox"/>	Yes <input type="checkbox"/> No <input type="checkbox"/>	
9.					Yes <input type="checkbox"/> No <input type="checkbox"/>	Yes <input type="checkbox"/> No <input type="checkbox"/>	
10.					Yes <input type="checkbox"/> No <input type="checkbox"/>	Yes <input type="checkbox"/> No <input type="checkbox"/>	
11.					Yes <input type="checkbox"/> No <input type="checkbox"/>	Yes <input type="checkbox"/> No <input type="checkbox"/>	
12.					Yes <input type="checkbox"/> No <input type="checkbox"/>	Yes <input type="checkbox"/> No <input type="checkbox"/>	
13.					Yes <input type="checkbox"/> No <input type="checkbox"/>	Yes <input type="checkbox"/> No <input type="checkbox"/>	
14.					Yes <input type="checkbox"/> No <input type="checkbox"/>	Yes <input type="checkbox"/> No <input type="checkbox"/>	
15.					Yes <input type="checkbox"/> No <input type="checkbox"/>	Yes <input type="checkbox"/> No <input type="checkbox"/>	
16.					Yes <input type="checkbox"/> No <input type="checkbox"/>	Yes <input type="checkbox"/> No <input type="checkbox"/>	
17.					Yes <input type="checkbox"/> No <input type="checkbox"/>	Yes <input type="checkbox"/> No <input type="checkbox"/>	
18.					Yes <input type="checkbox"/> No <input type="checkbox"/>	Yes <input type="checkbox"/> No <input type="checkbox"/>	
19.					Yes <input type="checkbox"/> No <input type="checkbox"/>	Yes <input type="checkbox"/> No <input type="checkbox"/>	
20.					Yes <input type="checkbox"/> No <input type="checkbox"/>	Yes <input type="checkbox"/> No <input type="checkbox"/>	



# Migration Instructions

---

This appendix contains instructions to migrate keys:

- **From a:** Key Management Station Version 1.x
- **To a:** Key Management System Version 2.0 system

---

## Prerequisites

A file of key data exported from a KMS 1.2 or later version database. This can be on any media, such as a CD-Rom, memory stick, or external hard drive.

**Note** – The Key Management Appliance (KMA) does not have a functioning CD- or DVD-drive. If exporting keys, make sure there is a system (PC or workstation) available that can connect to the Encryption Management Network, the KMS Manager, and the Key Management Appliances.

### Input File Format:

A KMS 1.x file containing exported keys will have the following format:

<Key ID>, <Key Value> [, <Description>]

Where:

- **Key ID** = A 64 character (hexadecimal) value that uniquely identifies each key;
- **Key Value** = A 64 character (hexadecimal) value that is the cypher value of the key;
- **Description** = An optional word or sentence used to describe each key.

**T10000** A tape drive firmware must be at **1.37.108** or higher to support KMS Version 2.0.

To upgrade the firmware in a T10000 tape drive, refer to:

<i>T10000 Service Manual</i>	StorageTek: 96175
<i>Virtual Operator Panel—Service</i>	StorageTek: 96180

## Basic Steps

- Export Keys from 1.0 KMS
- Do not create any new keys in 1.0 system after this  
Note: Keys are cleartext, protect them appropriately
- Import Keys into 2.0 KMS Cluster
- Upgrade Drive firmware
- Enroll drives with KMS Version 2.0 Cluster
- Agent configuration and VOP
- Drives begin using KMS Version 2.0
- Ensure that tapes written in 2.0 drives do not get loaded into 1.0 drives

---

# Description

The process is performed in three stage.

## Stage 1

The entire file is read and each line checked to ensure that the Key ID and Key Value are the appropriate length and format.

The first 4 characters of the Key ID are stripped off, as the KMS 2.0 Key ID is 30 bytes rather than the 32 bytes in the KMS 1.2 format. In addition, the Key ID is checked against the KMS 2.0 database to ensure it is unique.

- If the Key ID is not unique, the Key Value is checked against the KMS 2.0 Keystore for that Key ID.
- If a key exists in the KMS 2.0 database with the same Key ID and Key Value, that Key ID is noted and processing continues. When importing the keys has completed, the number of duplicate keys is returned.
- If a key exists in the KMS 2.0 database with the same Key ID but a different Key Value, then the operation is aborted and an error is returned immediately on the assumption that the KMS 1.2 file may be corrupt.

## Stage 2

The list of keys are processed, wrapping and adding the Key Value to the Keystore, and the Key data to the database.

Any errors in this stage result in the termination and proceed directly to Stage 3.

## Stage 3

This stage is only performed if there were any errors in Stage 2.

This stage removes the Key Values from the Keystore and rolls back the transaction to insert the Key data into the database.

In addition, an error message is returned to the GUI.

# Instructions

1. Mount the media containing the exported keys.
2. From the KMS Manager, select Import 1.0 Keys.
3. Enter the Key Group ID that these keys will be associated with.
4. Enter the path and file name for the key file.  
The status will be displayed upon completion.

**FIGURE B-1** Import Keys

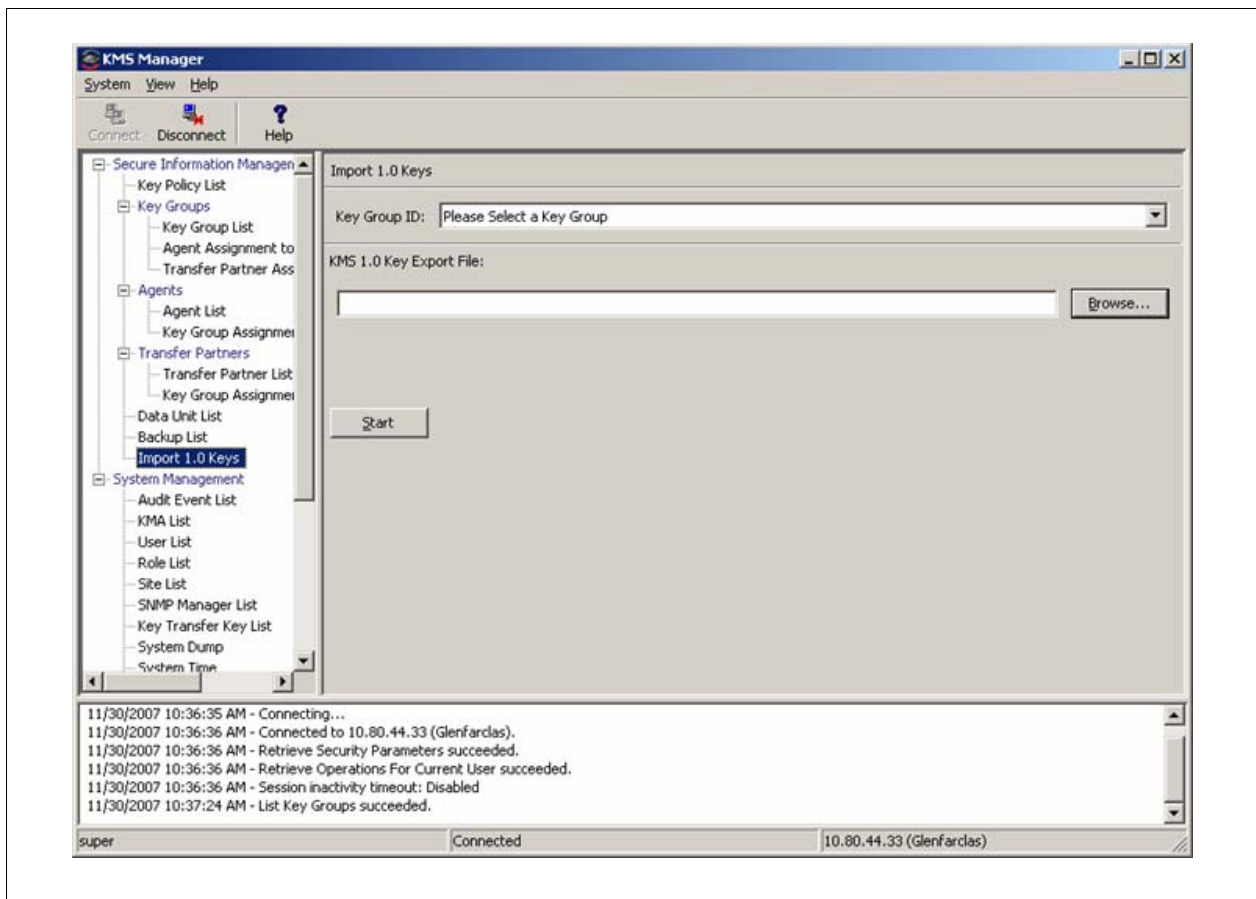



# Index

---

## Numerics

10000 rack kit, 59  
1400 library kit, 57  
180 library kit, 58  
3000 library kit, 51  
500 library kit, 52  
700 library kit, 57  
8500 library kit, 46  
9310 library kit, 53  
9741e drive cabinet kit, 53

## A

accessory racks, 48  
adapter, serial cable, 2  
adding  
    to a cluster, 28, 65  
    users, 22  
administrator guide, download site, 1  
agents  
    assign, 23  
    configure, 24  
    enroll, 23  
altitude, 6  
amber LED, 33  
APC switch, 50  
assign agents, 23  
auditors, 22  
autonomous unlocking preference, 19

## B

backup, 25  
    core security, 26  
    operators, 22  
    restore from, 68  
before beginning, 2

buttons, 5

## C

cabinet  
    9741e, 53  
    specifications, 7  
cable adapter, 2  
call center, 64, 74  
checklists  
    configuration, 21  
    enrollment, 35  
    preparation, 1  
    tape drives, 34  
cluster  
    adding to, 28, 65  
    how to create, 17  
compliance officers, 22  
conceptual drawings, 1  
configuration checklist, 21  
configure agents, 24  
connectors, 5  
core security backup, 26  
create a cluster, 17  
creating users, 22  
cross-over cable, 2  
cryptography, 1  
Customer Resource Center (CRC), xvi  
customer, satisfaction, 1  
customer-initiated maintenance, 64, 74  
cycling LEDs, 33

## D

depth, 6  
DHCP, 60  
dimensions, KMA, 6  
disable encryption, 71

- dispatch, 64, 74
- drawings, 1
- drive data, 36
- drive file structure, 38
- drive tray example, 49
- dump, system, 69
- Dynamic Host Configuration Protocol, 60

## E

### ELOM

- change password, 27
- commands, 9
- how to start, 9
- IP address, 8
- log in, 10
- network connection, 8, 9
- power control, 11
- QuickStart, 13
- redirection, 12
- remote control, 12
- start, 9

embedded Lights Out Manager *See* ELOM

encryption, 1

encryption LED, 33

enroll agents, 23

enrollment

- checklist, 35
- work sheet, 78

environmental parameters, 6

error-free installation, 1

Ethernet cable, 2

Ethernet connectors, 5

external rack installation, 50

## F

Fault LED, 5

Federal Information Processing Standards Publications, xiv

field replaceable units, 62

firmware upgrade, 67

front panel, 5

## G

graphical user interface, 8

green LED, 33

GUI

- installation, 21

- LAN connection, 8
- guides, xiv

## H

hardware kits, 45

heat output, 6

height, 6

help center, 64, 74

HyperTerminal session, 8

## I

indicators, tape drive, 33

initial configuration work sheet, 4, 36, 75

initial settings, 18

installation planning checklist, 1

IP addresses

- ELOM, 8
- initial set-up, 15
- KMS Manager, 16
- SDP, 60
- tape drives, 39

## J

Java, supported versions, 9

join a cluster, 17

## K

key groups, 23

Key Management Appliance *See* KMA

key migration, 81

key policies, 23

key split credentials, how to create, 18

keyboard, 10

keyboard entry, 15

KMA

- autonomous unlocking, 19
- backups, 25
- clusters, how to create/join, 17
- dimensions, 6
- front view, 5
- initial backup, 25
- initial configuration settings, 4
- installation tips, 14
- IP address range, 15
- key split credentials, 18
- QuickStart, 13
- rear view, 5

- Security Officer set-up, 19
- specifications, 6
- system upgrade, 67
- time settings, 20
- tips, 14
- KMS Manager
  - installation, 21
  - network connection, 8

## L

- L1400 library, 57
- L180 library, 58
- L700 library, 57
- LAN connections, 8
- LED for encryption, 33
- LEDs, 5, 33
- LEDs, tape drive status, 33
- license, tape drives, 39
- lights, 33
- local area network connections, 8
- L-Series library, 56

## M

- management network
  - LAN Connection, 8
- manual organization, xiii
- manuals, xiv
- mass storage, 6
- memory, 6
- migrate keys, 81
- monitor, 10
- monitor connector, 5
- mounting options, 6

## N

- null modem cable, 2

## O

- on/off switch
  - encryption, 71
- on/off switch, power, 5
- operators, 22
- organization of this manual, xiii

## P

- panel views, 5

- part numbers, tools, 2
- Partner Agreement, xvi
- Partners Web site, xvi
- parts, 62
- PC Key request form, 36
- PCIe, 6
- PCI-Express slots, 6
- permanently encrypting, 71
- planning for encryption, 1
- popup blockers, disable, 10
- PowderHorn library, 53
- power
  - button, 5
  - ELOM, 11
  - LED, 5
  - supply, 6
- power redundancy
  - SL8500, 46
  - switch, 50
- preparation checklist, 1
- processor, 6
- programs
  - embedded Lights Out Manager, 8
  - QuickStart, 13
  - wizard, 15
- publications, xiv

## Q

- QuickStart, 13
- quorum, 18

## R

- rack installation, 50
- rack space, L-Series libraries, 56
- rack specifications, 7
- rackmounted tape drives, 59
- rear panel, 5
- red LED, 33
- redirection, ELOM, 12
- related publications, documents, xiv
- relative humidity, 6
- remote control, ELOM, 12
- required tools, 2
- resellers, xvi
- restore
  - a cluster, 17
  - from backup, 68

## S

- SATA disk drive, 6
- SCA6000, 6
- SDP, 60
- Security Officer, initial settings, 19
- security officers, 22
- serial cable, 2
- serial port connector, 5
- service, 64, 74
- Service Delivery Platform, 60
- service network
  - LAN connection, 8
- SL3000 library, 51
- SL500 library, 52
- SL8500 library, 46
  - cabling example, 47
  - power redundancy, 46
  - racks, 48
- software upgrade, 67
- spares, 62
- specifications
  - KMA, 6
  - rack, 7
- split threshold, 18
- steps for partitioning, 76
- StorageTek
  - Customer Resource Center (CRC), xvi
  - Partners site, xvi
  - Web site, xvi
- subnet mask, SDP, 15
- Sun
  - Customer Resource Center (CRC), xvi
  - Partners Web site, xvi
  - Web site, xvi
- Sun Crypto Accelerator 6000, 6
- Sun Fire X2100 Specifications, 6
- support, 64, 74
- switch encryption off/on, 71
- system assurance, 1
- system dump, 69
- system upgrade, 67

## T

- T10000 rack kit, 59
- tape drives
  - 9741e cabinet, 53
  - checklist, 34
  - default IP address, 39

- drive tray, 49
- LED status, 33
- license, 39
- rackmount, 59
- work sheet, 77
- tasks for partitioning, 76
- technical support, 64, 74
- temperature, 6
- tokens, 72
- tools, 2
- trace dump, 69

## U

- upgrade, firmware, 67
- USB connectors, 5
- use roles work sheet, 76
- user IDs, 22

## V

- VGA connector, 5
- Virtual Operator Panel *See* VOP
- VOP
  - enroll tape drives, 41
  - license tape drives, 40
  - switch off encryption, 71
  - tokens, 72

## W

- Web browser, supported versions, 9
- Web sites, xvi
- weight, 6
- width, 6
- wizard, QuickStart program, 15
- work sheets, 73
  - enrollment, 78
  - initial configuration, 36, 75
  - preparation, 1
  - user roles, 76
- works sheets
  - tape drives, 77





Sun Microsystems, Inc. 4150 Network Circle, Santa Clara, CA 95054 USA Phone 1-650-960-1300 or 1-800-555-9SUN Web [sun.com](http://sun.com)



ARGENTINA: 5411-4317-5636 • AUSTRALIA: 1-800-550-786 • AUSTRIA: 43-1-601-26-0 • BALKANS: 301-6188-111 • BELGIUM: 32-2-704 89 83 • BRAZIL: 55-11-51872100 • BRUNEI: 65-216-8333 • CANADA: 1-800-422-8020 (GENERAL); 416-964-2001 (LEARNING MANAGEMENT SYSTEM SALES, TORONTO) • CHILE: 562-372-4500 • COLOMBIA: 571-629-2323  
CZECH REPUBLIC: 420-2-33009311 • DENMARK: 45-4556-5040 • EGYPT: 00-202-570-9442 • FINLAND: 358-9-525-551 • FRANCE: 33-1-41-33-17-17 • GERMANY: 49-89-460-08-2788 • GREECE: 30-01-6188101 • HONG KONG: 852-2877-7077 • HUNGARY: 361-202-4415 • INDIA: 91-80-229-8989 • INDONESIA: 65-216-8333 • IRELAND: 353-1-668-4377  
ISRAEL: 972-9-9710500 • ITALY: 39-02-9259511 • JAPAN: 81-3-5779-1820 • KOREA: 82-2-3453-6602 • MALAYSIA: 603-2116-1887 • MIDDLE EAST: 00-9714-3366333 • MEXICO: 525-261-0344 • NETHERLANDS: 31-33-4515200 • NEW ZEALAND: 0800-786-338 • NORTH WEST AFRICA: 00-9714-3366333 • NORWAY: FROM NORWAY: 47-22023950, TO NORWAY: 47-23369650 • PAKISTAN: 00-9714-3366333 • PEOPLE'S REPUBLIC OF CHINA: 8610-6803-5588 • PHILIPPINES: 632-885-7867 • POLAND: 48-22-8747848 • PORTUGAL: 351-21-413-4000 • RUSSIA: 7-095-935-8411 • SAUDI ARABIA: 00-9714-3366333 • SINGAPORE: 65-216-8300 • SOUTH AFRICA: 27-11-256-6300 • SPAIN: 34-902-210-412 • SRI LANKA: 65-2168333 • SWEDEN: 46-8-631-22-00 • SWITZERLAND: 41-1-908-90-50 (GERMAN) 41-22-999-0444 (FRENCH) • TAIWAN: 886-2-25185735 • THAILAND: 662-344-6855 • TURKEY: 90-212-335-22-00 • UNITED KINGDOM: 44-1276-416-520 • UNITED STATES: 1-800-422-8020 • VENEZUELA: 582-905-3800 • VIETNAM: 65-216-8333 • WORLDWIDE HEADQUARTERS: 1-650-960-1300

**SUN™** THE NETWORK IS THE COMPUTER ©2006 Sun Microsystems, Inc. All rights reserved. Sun, Sun Microsystems, and the Sun logo are trademarks or registered trademarks of Sun Microsystems, Inc. in the United States and other countries.