

---

# INSTALLATION INSTRUCTIONS

---

## Universal Pitch-Adjustable Wall Mount For Flat Panel Display PLP-91/D

Your new Wall Mount (PLP-91/D) is a quick disconnect mounting system with adjustability between 0 and 15 degrees pitch.

Once the Universal Flat Panel Display Wall Mount Bracket is attached to your display, simply attach the mount securely on a wall, lock the display in place using the convenient Q-latch, and attach your audio/video cables.

The PLP-91/D is virtually invisible when your display is mounted.

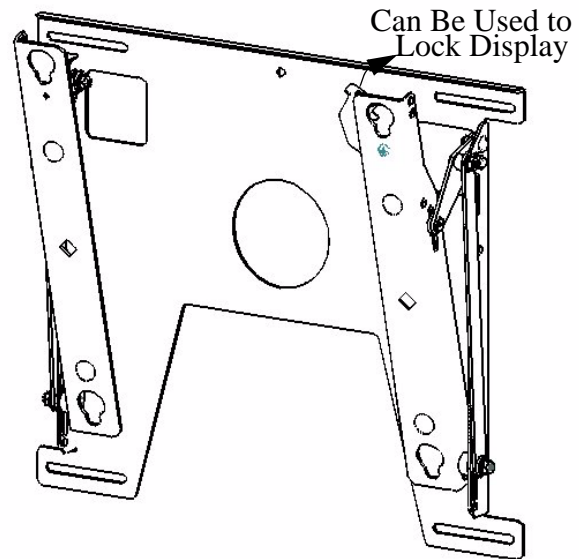

### BEFORE YOU BEGIN

---

- **Caution:** To prevent damage to the PLP-91/D, which could affect or void the Factory warranty, and to the equipment that will be attached to it, thoroughly study all instructions and illustrations before you begin the installation. Pay particular attention to the “Important Warnings and Precautions” on Page 1.
- The mount is designed to be installed using wall studs or supporting framework. The fasteners used to anchor the mount must be capable of supporting five times the total weight of the equipment.
- The maximum weight to be installed on the Universal Pitch-Adjustable Wall Mount is 125 pounds (56.7 Kg).

---

Sony Electronics Inc. 8805-000087  
1 Sony Drive  
Park Ridge, NJ 07656  
201-930-1000  
[www.sony.com/displaysystems](http://www.sony.com/displaysystems)

---



## IMPORTANT WARNINGS AND PRECAUTIONS!

- WARNING:** A **WARNING** alerts you to the possibility of serious injury or death if you do not follow the instructions.
- CAUTION:** A **CAUTION** alerts you to the possibility of damage or destruction of equipment if you do not follow the corresponding instructions.
- **WARNING:** Improper installation can result in serious personal injury! Make sure that the structural members can support a weight factor *five times* the total weight of the equipment. If not, reinforce the structure before installing the mount.
  - **WARNING:** Be aware also of the potential for personal injury or damage to the unit if it is not adequately mounted.
  - **WARNING:** The installer is responsible for verifying that the wall to which the mount is anchored will safely support the combined load of all attached components or other equipment.
  - **WARNING:** Watch for pinch points. Do not put your fingers between movable parts.
  - **WARNING:** Make sure the mount and brackets are correctly oriented.
  - **WARNING:** Make sure the latching flag securing the display is completely engaged at all times *except* when removing or installing the display. The latching flag must be all completely engaged when installing/removing cables.
  - **CAUTION:** Check the unit for shipping damage before you begin the installation.
  - **CAUTION:** Use only the mounting screws provided and **DO NOT OVER TIGHTEN** mounting screws.

## CONTENTS

DIMENSIONAL DRAWING .....	3
INSTALL MOUNT .....	4
INSTALL PSB-91/D DISPLAY BRACKETS.....	4
MOUNT THE DISPLAY .....	6

## TOOLS REQUIRED FOR INSTALLATION

- Phillips screwdrivers, No. 1 and No. 2 TIP
- Drill and bit set
- Wrench set

**NOTE:** Other tools may be required depending on the method of installation.

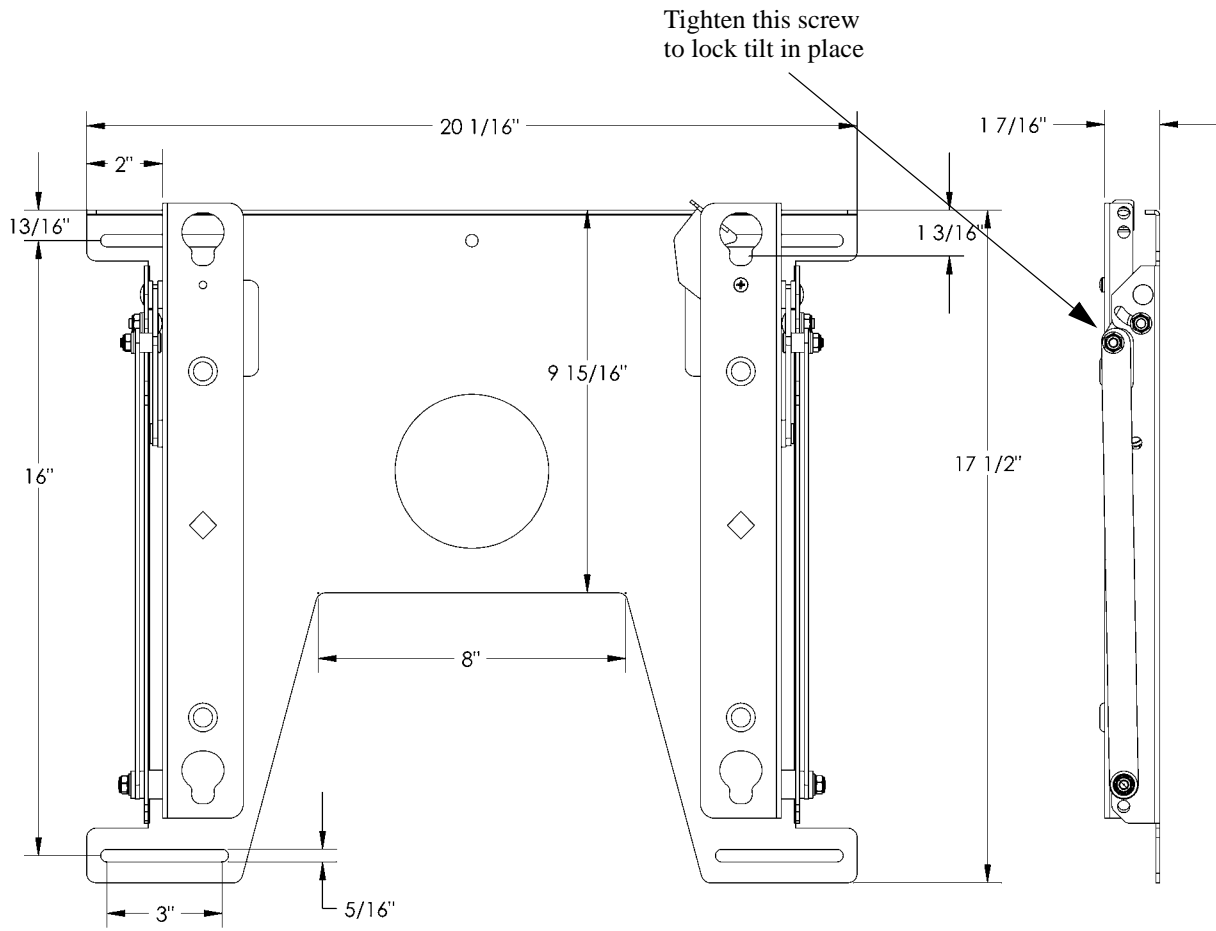

DIMENSIONAL DRAWING

## INSTALL MOUNT

Install the mount as follows:

1. Determine the exact mounting location prior to installation and draw a level line to indicate the desired height for the top of the mounting plate.

**WARNING: Improper installation can result in serious personal injury! Make sure that the structural framework can support a weight factor five times the total weight of the equipment. If not, reinforce the structure before installing the mount.**

2. With the mount correctly oriented and level, secure the mount to the wall (see Figure 1) using four fasteners (not included). Fasteners must be driven into the supporting wall studs or other supporting framework.
3. Check mount to ensure it is level and adjust to level if necessary.

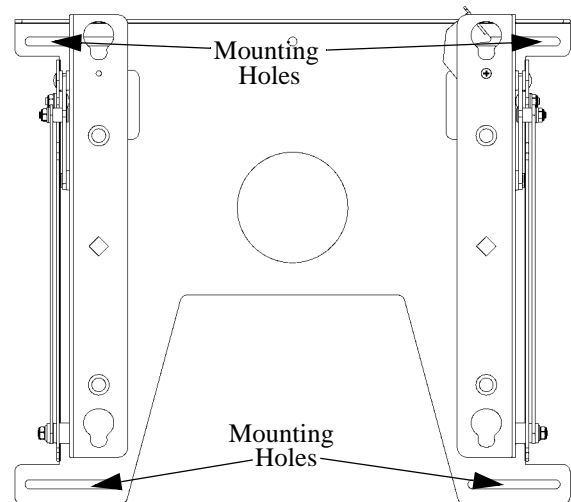

Figure 1. Mounting Hole Locations

## INSTALL PSB-91/D DISPLAY BRACKETS

1. Using a 10-24 button head cap screw inserted from the back side of the bracket, secure the mounting button, with chamfered hole of mounting button (larger surface) facing the bracket, to bracket (four places) (see Figure 2 and Figure 3).
2. Place Nylon spacers over the mounting holes on the back of the screen.

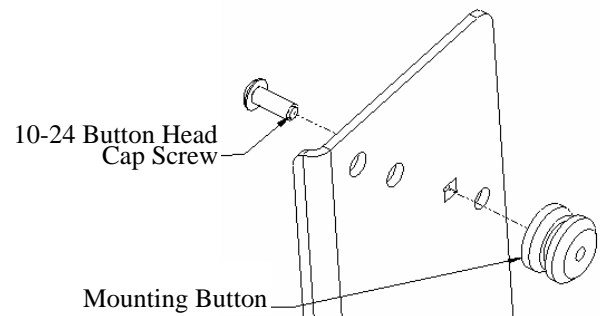

Figure 2. Mounting Button Attachment

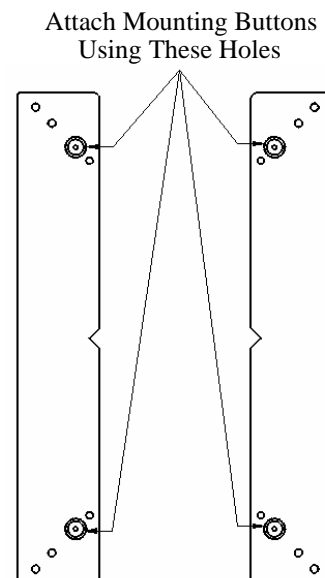

Figure 3. Mounting Button Location

- 3. Attach mounting brackets to the display using the M5 screws for 32" screen or M6 for the 42" and 50" screens (see Figure 4 and Figure 5).

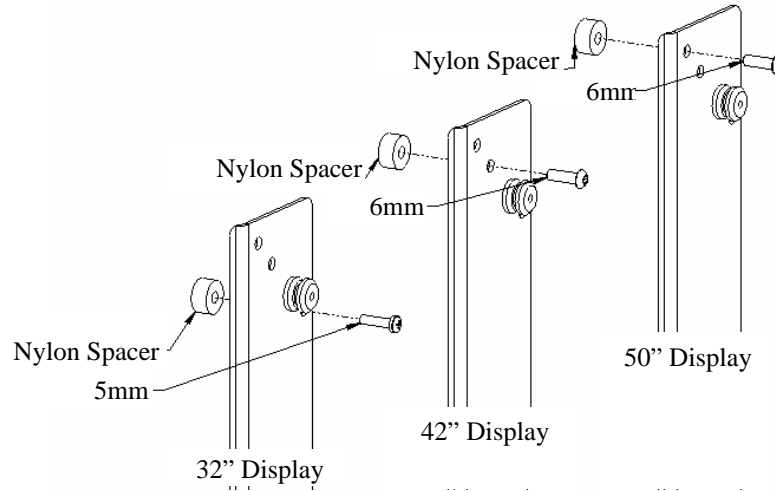

Figure 4. Bracket Hole Location

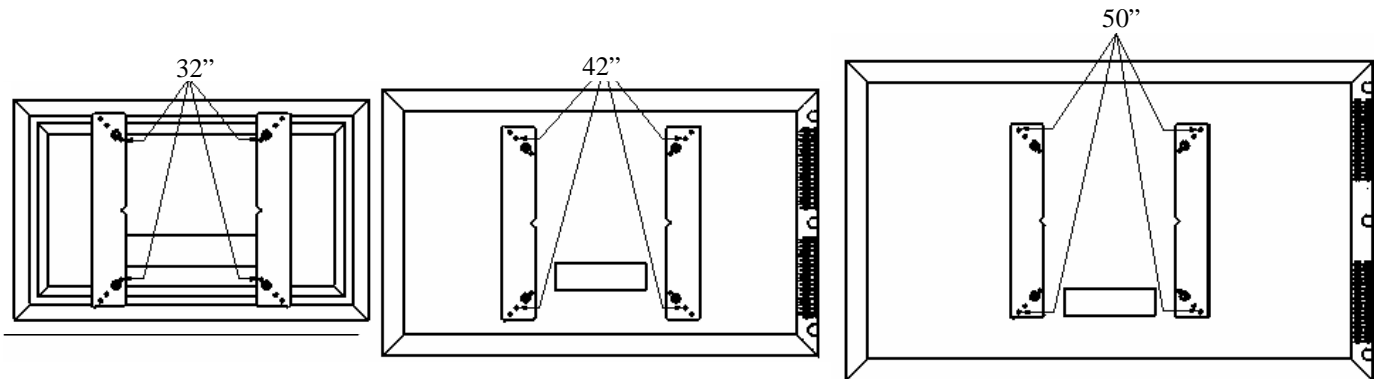

Figure 5. Bracket Attachment Location

## MOUNT THE DISPLAY

Mount the display as follows:

1. Make sure no power is supplied to the display and the flag is in the lowered (open) position before attempting to mount the display.
2. Using two people, slide the display down over the mount. Make sure all four Q-buttons of the display engage all four slots in the mount.
3. With the Q-buttons of the display fully engaged in the slots of the mount, secure the display on the mount by raising the flag all the way to their locked position. *If the flag does not fully engage, remove the display and make sure the brackets are correctly installed.*

**NOTE:** A security lock may be installed through the hole in the locking flag for additional security (see Figure 6).

**NOTE:** If display does not remain at desired tilt setting, tighten the nut and bolt on tilt arms on each side (see Figure 7).

**WARNING:** Make sure the flag securing the display is completely lowered at all times except when removing or installing the display. The flag must be all the way down when installing/removing cables.

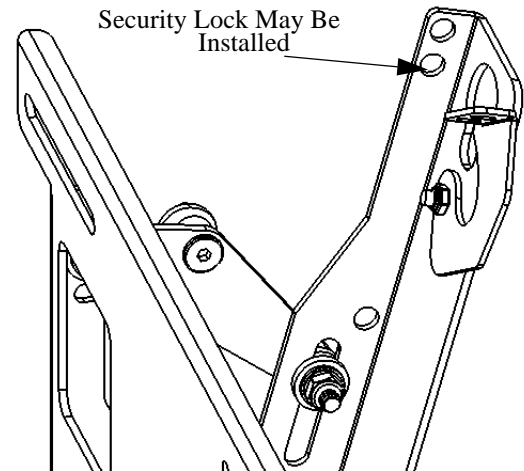

Figure 6. Optional Security

Loosen or tighten  
this bolt  
to adjust tilt tension  
or lock in place

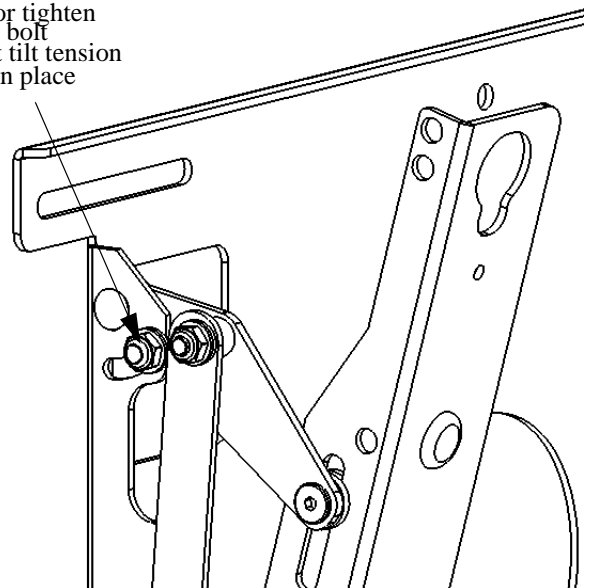

Figure 7. Tilt Tension Adjustment