

EXECUTIVE

By **PRO-FORM**®

Model No. HGBE8991.1

Serial No. _____

Write the serial number in the space above for reference.

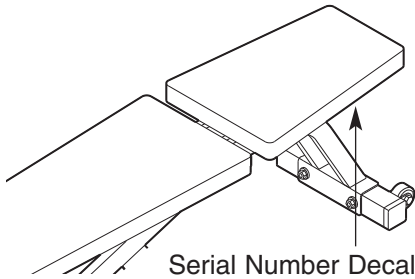

USER'S MANUAL

QUESTIONS?

As a manufacturer, we are committed to providing complete customer satisfaction. If you have questions, or if a part is damaged or missing, PLEASE CONTACT OUR CUSTOMER SERVICE DEPARTMENT DIRECTLY.

CALL TOLL-FREE:

1-888-553-1333

Mon.–Fri., 6 a.m.–6 p.m. MST

ON THE WEB:

www.proformservice.com

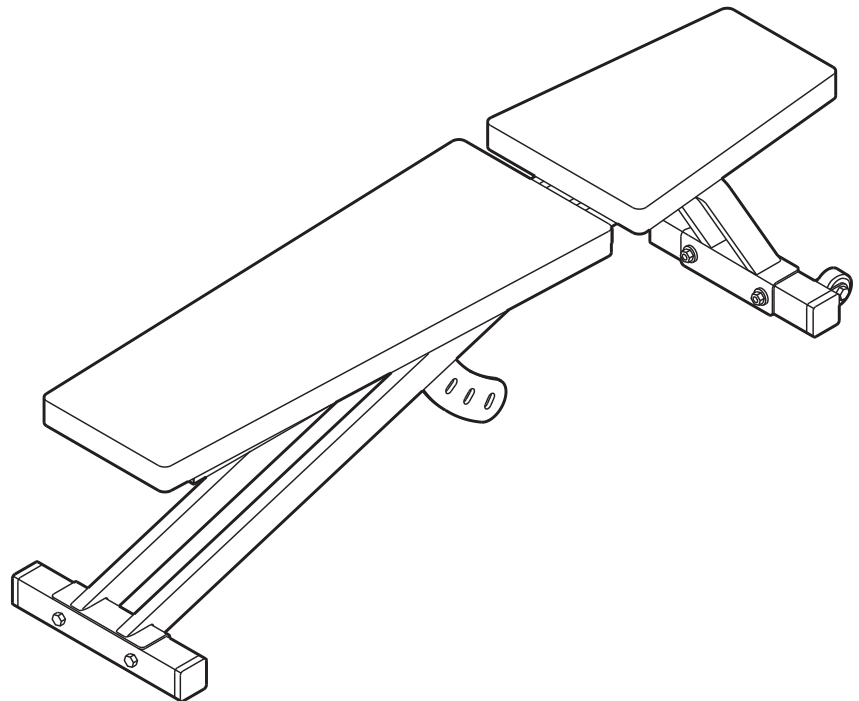

CAUTION

Read all precautions and instructions in this manual before using this equipment. Save this manual for future reference.



Visit our website at

www.proform.com

*new products, prizes,
fitness tips, and much more!*

TABLE OF CONTENTS

WARNING DECAL PLACEMENT	2
IMPORTANT PRECAUTIONS	3
BEFORE YOU BEGIN	4
PART IDENTIFICATION CHART	5
ASSEMBLY	6
ADJUSTMENTS	9
EXERCISE GUIDELINES	11
PART LIST	14
EXPLODED DRAWING	15
ORDERING REPLACEMENT PARTS	Back Cover
LIMITED WARRANTY	Back Cover

WARNING DECAL PLACEMENT

The decal shown here has been placed on the weight bench in the indicated location. If the decal is missing or illegible, please call the toll-free telephone number on the front cover of this manual and order a free replacement decal. Apply the decal in the location shown.

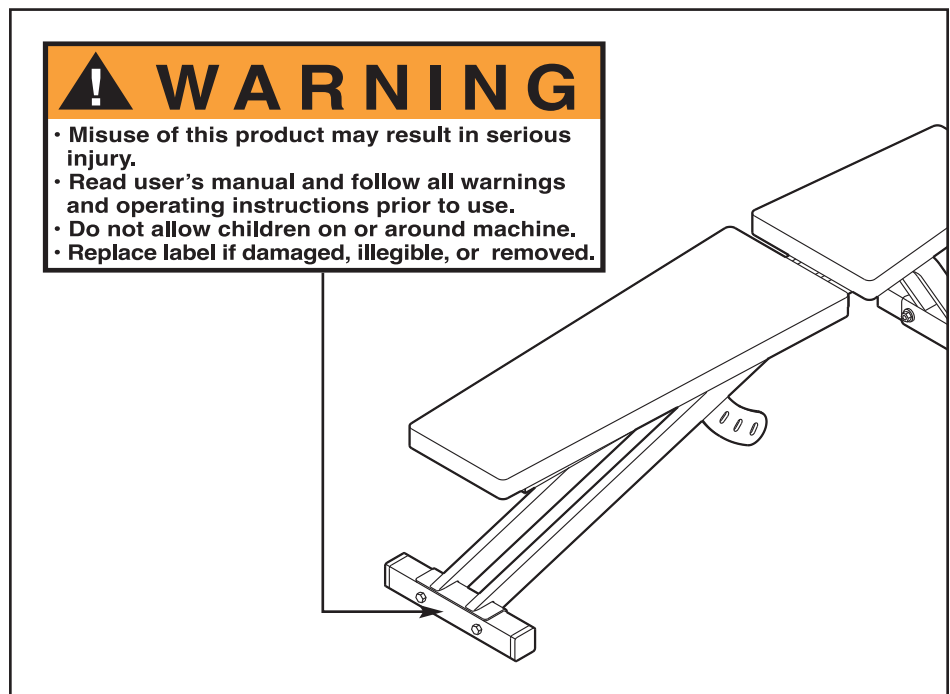

IMPORTANT PRECAUTIONS

⚠️ WARNING: To reduce the risk of serious injury, read the following important precautions before using the weight bench.

1. Read all instructions in this manual and all warnings on the weight bench before using the weight bench. Use the weight bench only as described in this manual.
2. It is the responsibility of the owner to ensure that all users of the weight bench are adequately informed of all precautions.
3. The weight bench is intended for home use only. Do not use the weight bench in a commercial, rental, or institutional setting.
4. Keep the weight bench indoors, away from moisture and dust. Place the weight bench on a level surface, with a mat beneath it to protect the floor or carpet. Make sure that there is enough clearance around the weight bench to mount, dismount, and use the weight bench.
5. Keep children under 12 and pets away from the weight bench at all times.
6. Inspect and properly tighten all parts regularly. Replace any worn parts immediately.
7. Make sure the adjustment knobs are fully engaged into the adjustment brackets before using the weight bench.
8. Always wear athletic shoes for foot protection while exercising.
9. The weight bench is designed to support a maximum user weight of 250 pounds and a maximum of 210 pounds of weights.
10. If you feel pain or dizziness at any time while exercising, stop immediately and begin cooling down.

⚠️ WARNING: Before beginning this or any exercise program, consult your physician. This is especially important for persons over the age of 35 or persons with pre-existing health problems. Read all instructions before using. ICON assumes no responsibility for personal injury or property damage sustained by or through the use of this product.

BEFORE YOU BEGIN

Thank you for selecting the versatile EXECUTIVE BY PROFORM® weight bench. The weight bench is designed to help you develop the major muscle groups of the upper body. Whether your goal is a shapely figure, an increase in muscle size and strength, or a healthier cardiovascular system, the weight bench will help you achieve the specific results you want.

For your benefit, read this manual carefully before using the weight system. If you have questions after reading this manual, see the front cover of this manual. To help us assist you, please note the product

model number and serial number before calling. The model number is HGBE8991.1. The serial number can be found on a decal attached to the weight bench (see the front cover of this manual).

To avoid a registration fee for any service needed under warranty, you must register the weight bench at www.proformservice.com/registration.

Before reading further, please review the drawing below and familiarize yourself with the parts that are labeled.

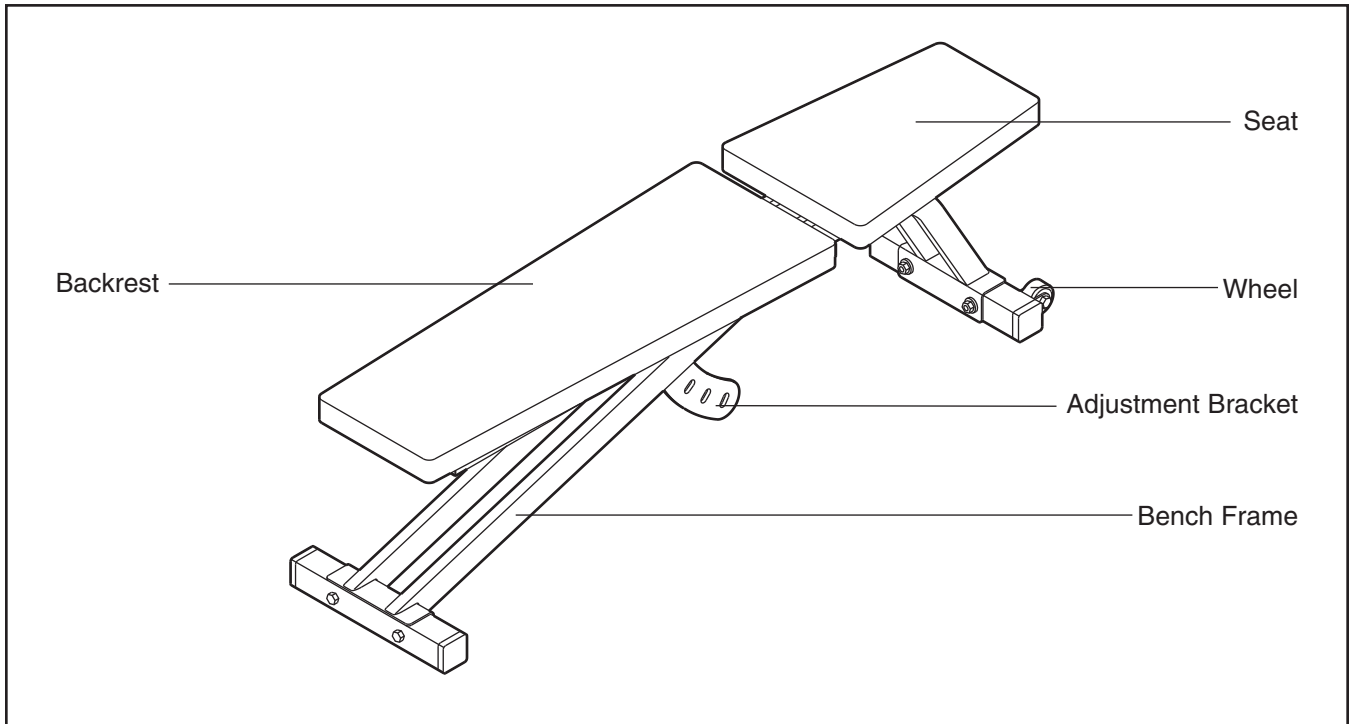

PART IDENTIFICATION CHART

This chart is provided to help you identify the small parts used in assembly. The number in parentheses below each part is the key number of the part from the PART LIST on page 14 of this manual. **Important: Some parts may have been pre-assembled for shipping purposes. If you cannot find a part in the parts bags, check to see if it has been pre-assembled.**

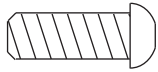

M6 x 16mm Screw (17)



M6 x 38mm Screw (21)

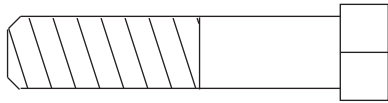

M10 x 44mm Bolt (15)

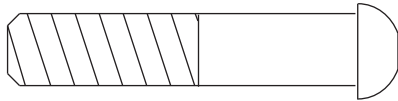

M10 x 46mm Button Bolt (18)



M6 x 63mm Screw (19)

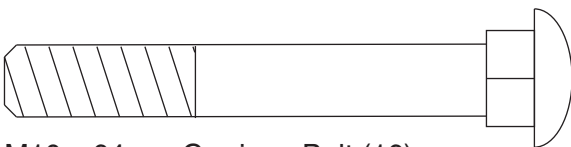

M10 x 64mm Carriage Bolt (16)

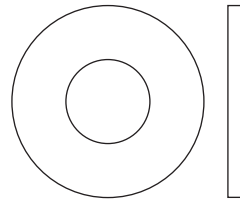

M10 Washer (22)

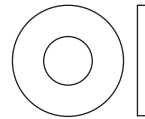

M6 Washer (23)

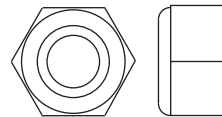

M10 Nylon Locknut (20)



M10 x 231mm Hex Bolt (14)

ASSEMBLY

Make Things Easier for Yourself

This manual is designed to ensure that the weight bench can be assembled successfully by anyone. Most people find that by setting aside plenty of time, assembly will go smoothly.



To hire an authorized service technician to assemble the weight system, call toll-free 1-800-445-2480.

Before beginning assembly, carefully read the following information and instructions:

- Assembly requires two people.
- Place all parts in a cleared area and remove the packing materials. Do not dispose of the packing materials until assembly is completed.

- For help identifying small parts, use the **PART IDENTIFICATION CHART** on page 5.
- As you assemble the weight bench, make sure all parts are oriented as shown in the drawings.
- Tighten all parts as you assemble them, unless instructed to do otherwise.

In addition to the included allen wrench, assembly requires the following tools (not included):

- Two adjustable wrenches 
- One rubber mallet 
- Lubricant, such as grease or petroleum jelly.

Assembly will be more convenient if you have a socket set, a set of open-end or closed-end wrenches, or a set of ratchet wrenches.

1. Before beginning, make sure that you understand the information in the box above. Note: Some parts described in the assembly steps may be pre-assembled.

Press a 50mm Square Inner Cap (10) into each end of the Rear Stabilizer (1).

Attach the Rear Stabilizer (1) to the indicated end of the Bench Frame (2) with two M10 x 64mm Carriage Bolts (16) and two M10 Nylon Locknuts (20).

2. Press a 50mm Square Inner Cap (10) into each end of the Front Stabilizer (3).

Attach the two Wheels (13) to the brackets on the Front Stabilizer (3) with two M10 x 46mm Bolts (18) and two M10 Nylon Locknuts (20).

Attach the Front Stabilizer (3) to the indicated end of the Bench Frame (2) with two M10 x 64mm Carriage Bolts (16) and two M10 Nylon Locknuts (20).

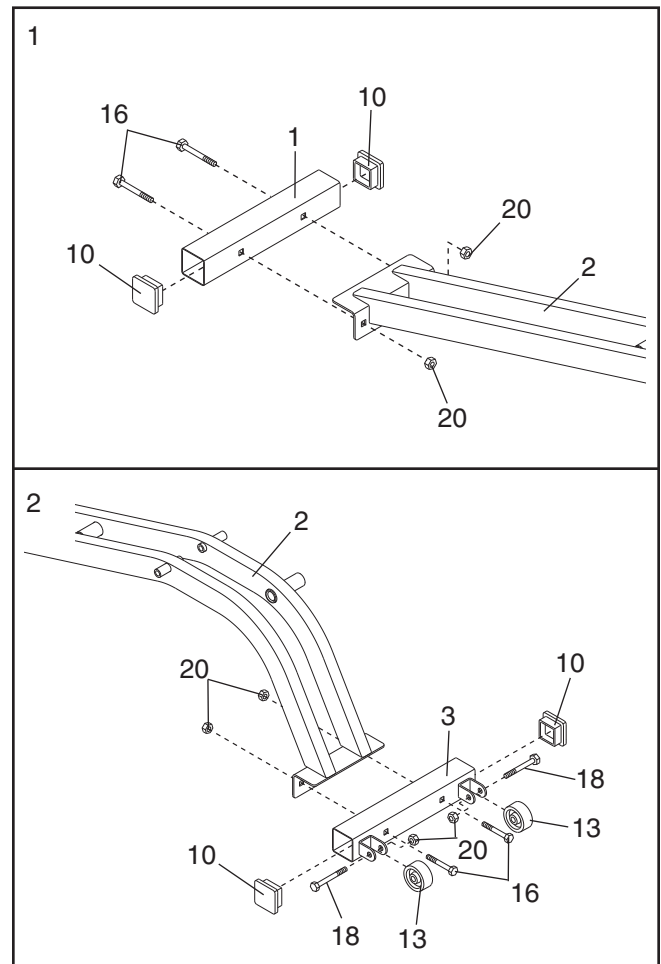

3. Press a 50mm Thick Square Inner Cap (11) into each end of the Seat Frame (4).

Orient the Seat (7) as shown. Attach the Seat to the Seat Frame (4) with two M6 x 16mm Screws (17), an M6 x 63mm Screw (19), and an M6 Washer (23).

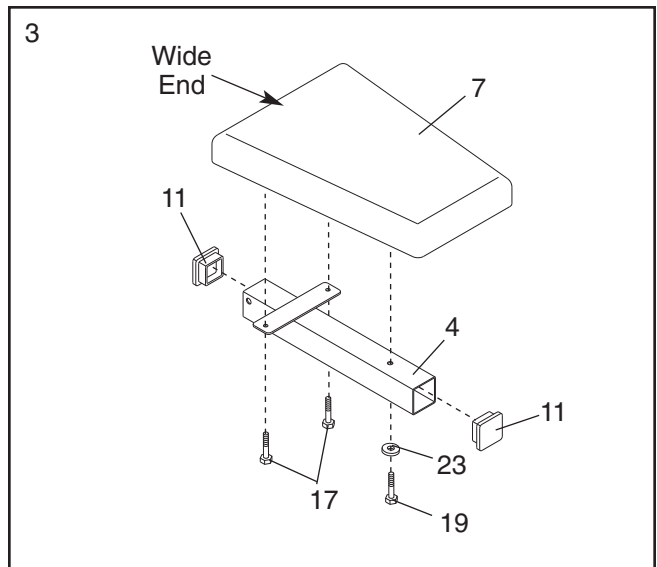

4. Press two 1" Square Inner Caps (12) into each Backrest Frame (6).

Orient the Backrest Frames (6) exactly as shown. Attach the Adjustment Bracket (5) to the Backrest Frames with four M10 x 44mm Bolts (15) and four M10 Nylon Locknuts (20).

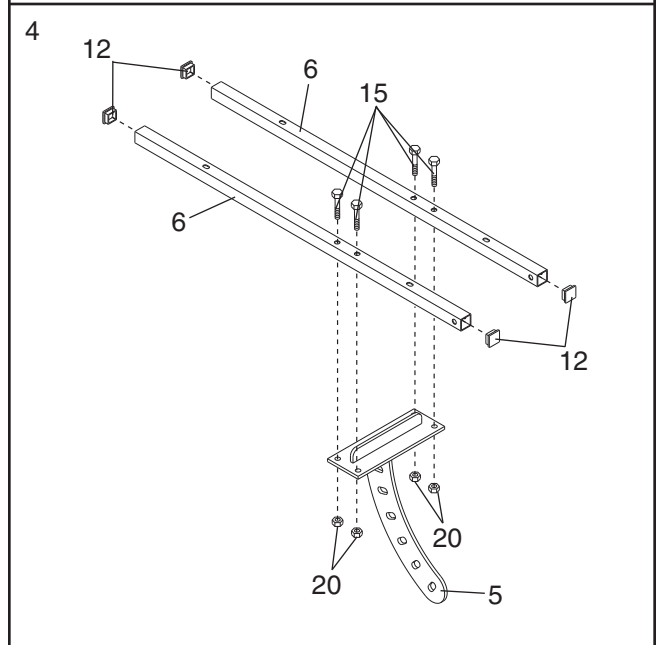

5. Orient the Backrest (8) as shown. Attach the Backrest to the Backrest Frames (6) with four M6 x 38mm Screws (21) and four M6 Washers (23). Note: If the holes in the Backrest Frames do not line up with the holes in the Backrest, go back to assembly step 4, loosen the M10 Nylon Locknuts (20), adjust the positions of the Backrest Frames, and then retighten the Nylon Locknuts.

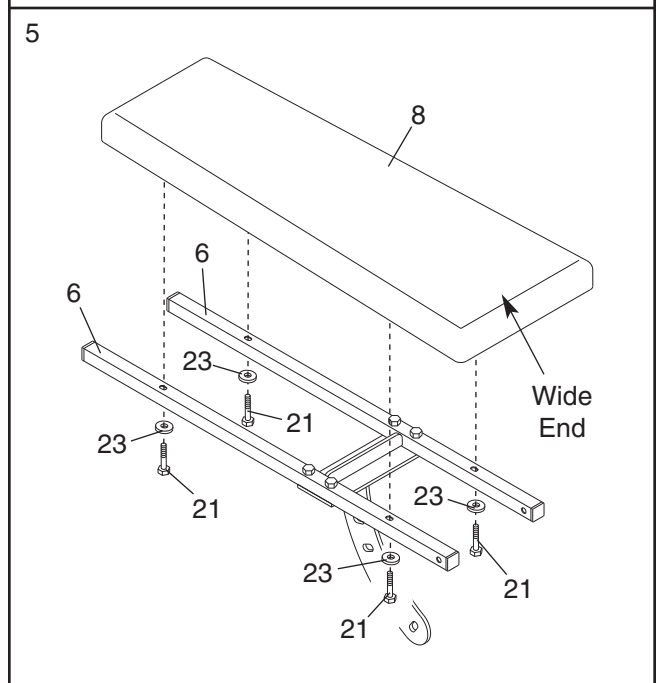

6. **Refer to the inset drawing.** Pull out the indicated Adjustment Knob (9) as far as possible. Tip the Seat (7) toward the Knob, and insert the Seat Frame (4) between the two tubes of the Bench Frame (2) as shown. **Make sure that the pin on the Seat Frame is under the right tube.** Next, slide the Seat Frame forward until the indicated hole is aligned with the small tube on the Bench Frame. Then, release the Adjustment Knob so that it engages one of the adjustment holes in the Seat Frame.

Next, pull out the other Adjustment Knob (9) as far as possible. Insert the Adjustment Bracket (5) between the two tubes of the Bench Frame (2), and then release the Adjustment Knob so that it engages one of the middle adjustment holes in the Adjustment Bracket.

Lubricate the M10 x 231mm Hex Bolt (14). Attach the Backrest Frames (6) and the Seat Frame (4) to the Bench Frame (2) with the Bolt, two M10 Washers (22), and an M10 Nylon Locknut (20). **Do not overtighten the Nylon Locknut; the Seat Frame and the Backrest Frames must be able to pivot easily.**

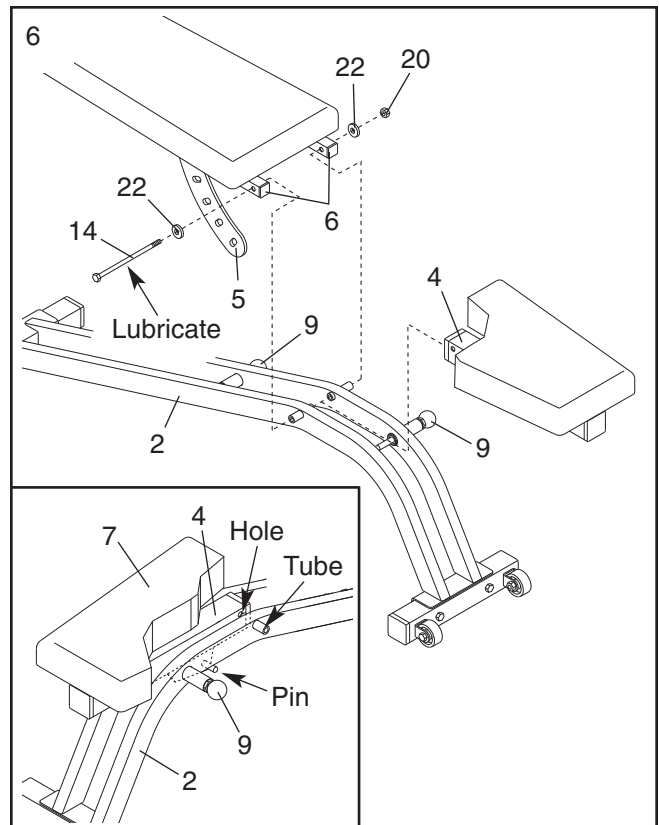

7. **Make sure that all parts are properly tightened before you use the weight bench. The use of the remaining parts will be explained in ADJUSTMENTS, starting on the following page.**

ADJUSTMENTS

The weight bench is designed to be used with the weight rack (HGBC5991/HGBM5991/HGBO5991) and set of dumbbells (HGWT0591) included with the HIDDEN GROVE furniture. The steps below explain how the weight bench can be adjusted. See EXERCISE GUIDELINES on page 11 for important exercise information.

Make sure that all parts are properly tightened each time the weight bench is used. Replace any worn parts immediately. The weight bench can be cleaned with a damp cloth and a mild, non-abrasive detergent. **Do not use solvents.**

ADJUSTING THE SEAT

To adjust the Seat (7), pull out the front Adjustment Knob (9) as far as possible. Move the Seat to the desired position, and then release the Adjustment Knob so that it engages one of the adjustment holes in the Seat Frame.

⚠ WARNING: Make sure that the Adjustment Knob (9) is fully inserted into an adjustment hole in the Seat Frame (4) before using the weight bench.

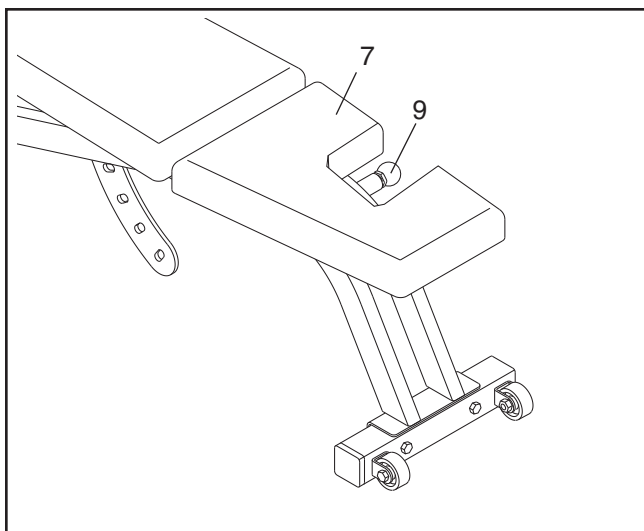

ADJUSTING THE BACKREST

The Backrest (8) can be used in a declined position, a level position, or one of four inclined positions. To adjust the Backrest, pull out the rear Adjustment Knob (9) as far as possible. Move the Backrest to the desired position, and then release the Adjustment Knob so that it engages one of the adjustment holes in the Adjustment Bracket.

⚠ WARNING: Make sure that the Adjustment Knob (9) is fully inserted into an adjustment hole in the Adjustment Bracket (5) before using the weight bench.

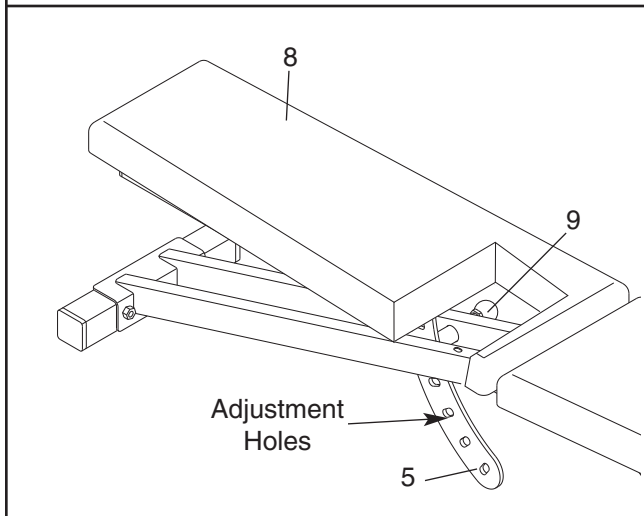

STORING THE WEIGHT BENCH

To store the weight bench, place the Wheels (13) in the base bracket on the weight rack included with the HIDDEN GROVE furniture. Lift the Rear Stabilizer (1) so that it rests between the uprights.

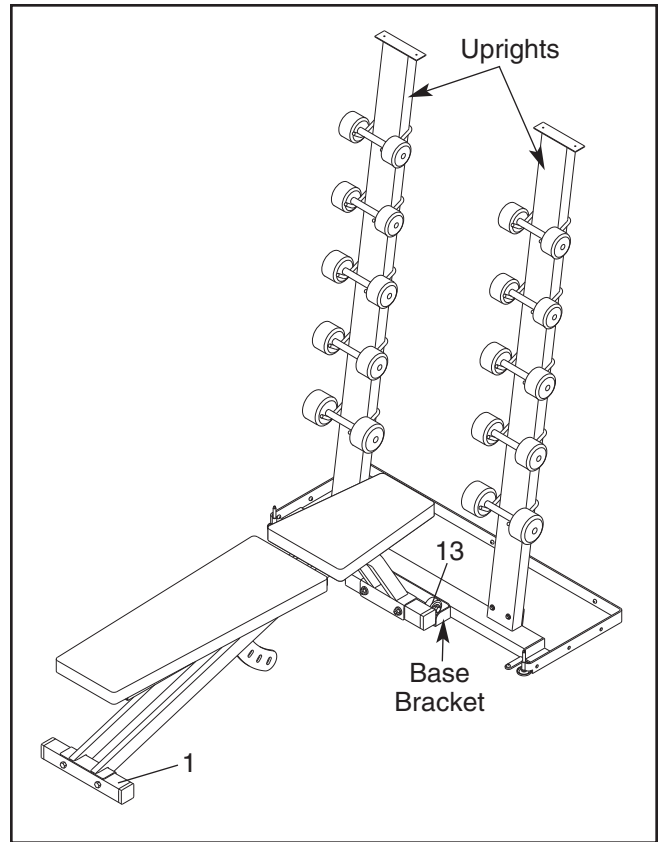

EXERCISE GUIDELINES

THE FOUR BASIC TYPES OF WORKOUTS

Muscle Building

To increase the size and strength of your muscles, push them close to their maximum capacity. Your muscles will continually adapt and grow as you progressively increase the intensity of your exercise. You can adjust the intensity level of an individual exercise in two ways:

- by changing the amount of weight used
- by changing the number of repetitions or sets performed. (A “repetition” is one complete cycle of an exercise, such as one sit-up. A “set” is a series of repetitions.)

The proper amount of weight for each exercise depends upon the individual user. You must gauge your limits and select the amount of weight that is right for you. Begin with 3 sets of 8 repetitions for each exercise you perform. Rest for 3 minutes after each set. When you can complete 3 sets of 12 repetitions without difficulty, increase the amount of weight.

Toning

You can tone your muscles by pushing them to a moderate percentage of their capacity. Select a moderate amount of weight and increase the number of repetitions in each set. Complete as many sets of 15 to 20 repetitions as possible without discomfort. Rest for 1 minute after each set. Work your muscles by completing more sets rather than by using high amounts of weight.

Weight Loss

To lose weight, use a low amount of weight and increase the number of repetitions in each set. Exercise for 20 to 30 minutes, resting for a maximum of 30 seconds between sets.

Cross Training

Cross training is an efficient way to get a complete and well-balanced fitness program. An example of a balanced program is:

- Plan weight training workouts on Monday, Wednesday, and Friday.
- Plan 20 to 30 minutes of aerobic exercise, such as cycling or swimming, on Tuesday and Thursday.
- Rest from both weight training and aerobic exercise for at least one full day each week to give your body time to regenerate.

The combination of weight training and aerobic exercise will reshape and strengthen your body, plus develop your heart and lungs.

PERSONALIZING YOUR EXERCISE PROGRAM

Determining the exact length of time for each workout, as well as the number of repetitions or sets completed, is an individual matter. It is important to avoid overdoing it during the first few months of your exercise program. You should progress at your own pace and be sensitive to your body’s signals. If you experience pain or dizziness at any time while exercising, stop immediately and begin cooling down. Find out what is wrong before continuing. Remember that adequate rest and a proper diet are important factors in any exercise program.

WARMING UP

Begin each workout with 5 to 10 minutes of stretching and light exercise to warm up. Warming up prepares your body for more strenuous exercise by increasing circulation, raising your body temperature and delivering more oxygen to your muscles.

WORKING OUT

Each workout should include 6 to 10 different exercises. Select exercises for every major muscle group, emphasizing areas that you want to develop most. To give balance and variety to your workouts, vary the exercises from session to session.

Schedule your workouts for the time of day when your energy level is the highest. Each workout should be followed by at least one day of rest. Once you find the schedule that is right for you, stick with it.

EXERCISE FORM

Maintaining proper form is an essential part of an effective exercise program. This requires moving through the full range of motion for each exercise, and moving only the appropriate parts of the body. Exercising in an uncontrolled manner will leave you feeling exhausted.

The repetitions in each set should be performed smoothly and without pausing. The exertion stage of each repetition should last about half as long as the return stage. Proper breathing is important. Exhale during the exertion stage of each repetition and inhale during the return stroke. Never hold your breath.

Rest for a short period of time after each set. The ideal resting periods are:

- Rest for three minutes after each set for a muscle building workout.

- Rest for one minute after each set for a toning workout.
- Rest for 30 seconds after each set for a weight loss workout.

Plan to spend the first couple of weeks familiarizing yourself with the equipment and learning the proper form for each exercise.

COOLING DOWN

End each workout with 5 to 10 minutes of stretching. Include stretches for both your arms and legs. Move slowly as you stretch and do not bounce. Ease into each stretch gradually and go only as far as you can

without strain. Stretching at the end of each workout is an effective way to increase flexibility.

STAYING MOTIVATED

For motivation, keep a record of each workout. The chart on page 13 of this manual can be photocopied and used to schedule and record your workouts. List the date, the exercises performed, the weight used, and the numbers of sets and repetitions completed. Record your weight and key body measurements at the end of every month. Remember, the key to achieving the greatest results is to make exercise a regular and enjoyable part of your everyday life.

MUSCLE CHART

- A. Sternomastoid (neck)
- B. Pectoralis Major (chest)
- C. Biceps (front of arm)
- D. Obliques (waist)
- E. Brachioradials (forearm)
- F. Hip Flexors (upper thigh)
- G. Abductor (outer thigh)
- H. Quadriceps (front of thigh)
- I. Sartorius (front of thigh)
- J. Tibialis Anterior (front of calf)
- K. Soleus (front of calf)
- L. Rectus Abdominus (stomach)
- M. Adductor (inner thigh)
- N. Trapezius (upper back)
- O. Rhomboideus (upper back)
- P. Deltoid (shoulder)
- Q. Triceps (back of arm)
- R. Latissimus Dorsi (mid back)
- S. Spinae Erectors (lower back)
- T. Gluteus Medius (hip)
- U. Gluteus Maximus (buttocks)
- V. Hamstring (back of leg)
- W. Gastrocnemius (back of calf)

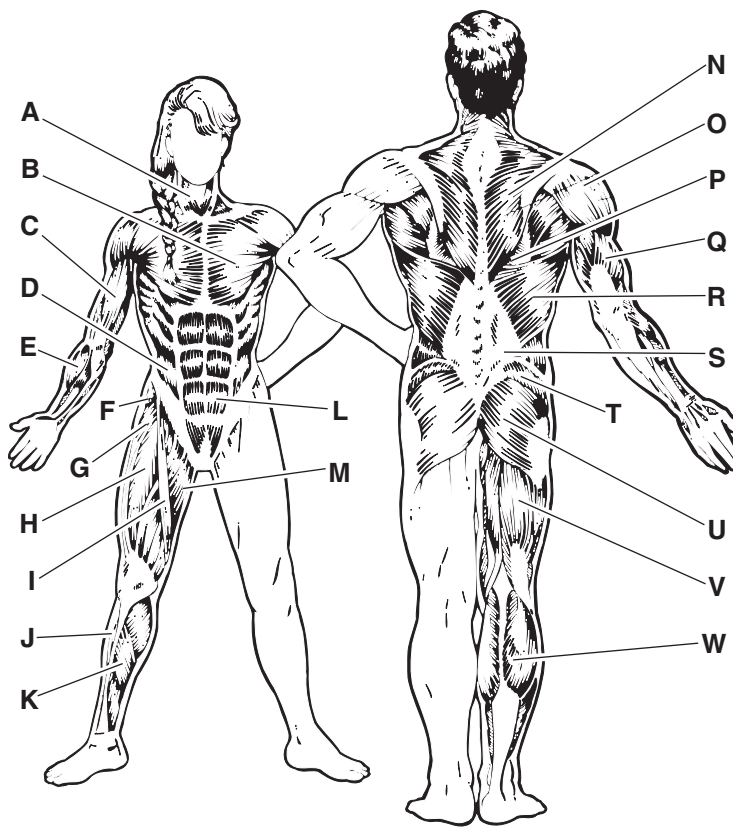

MONDAY	EXERCISE	WEIGHT	SETS	REPS
Date: _____ / _____ / _____				

TUESDAY AEROBIC EXERCISE

Date: _____ / _____ / _____

WEDNESDAY	EXERCISE	WEIGHT	SETS	REPS
Date: _____ / _____ / _____				

THURSDAY AEROBIC EXERCISE

Date: _____ / _____ / _____

FRIDAY	EXERCISE	WEIGHT	SETS	REPS
Date: _____ / _____ / _____				

Make photocopies of this page for scheduling and recording your workouts.

PART LIST—Model No. HGBE8991.1

R0305A

Key No.	Qty.	Description	Key No.	Qty.	Description
1	1	Rear Stabilizer	13	2	Wheel
2	1	Bench Frame	14	1	M10 x 231mm Hex Bolt
3	1	Front Stabilizer	15	4	M10 x 44mm Bolt
4	1	Seat Frame	16	4	M10 x 64mm Carriage Bolt
5	1	Adjustment Bracket	17	2	M6 x 16mm Screw
6	2	Backrest Frame	18	2	M10 x 46mm Button Bolt
7	1	Seat	19	1	M6 x 63mm Screw
8	1	Backrest	20	11	M10 Nylon Locknut
9	2	Adjustment Knob	21	4	M6 x 38mm Screw
10	4	50mm Square Inner Cap	22	2	M10 Washer
11	2	50mm Thick Square Inner Cap	23	5	M6 Washer
12	4	1" Square Inner Cap	#	1	User's Manual

Note: “#” indicates a non-illustrated part. Specifications are subject to change without notice. See the back cover of this manual for information about ordering replacement parts.

EXPLODED DRAWING—Model No. HGBE8991.1

R0305A

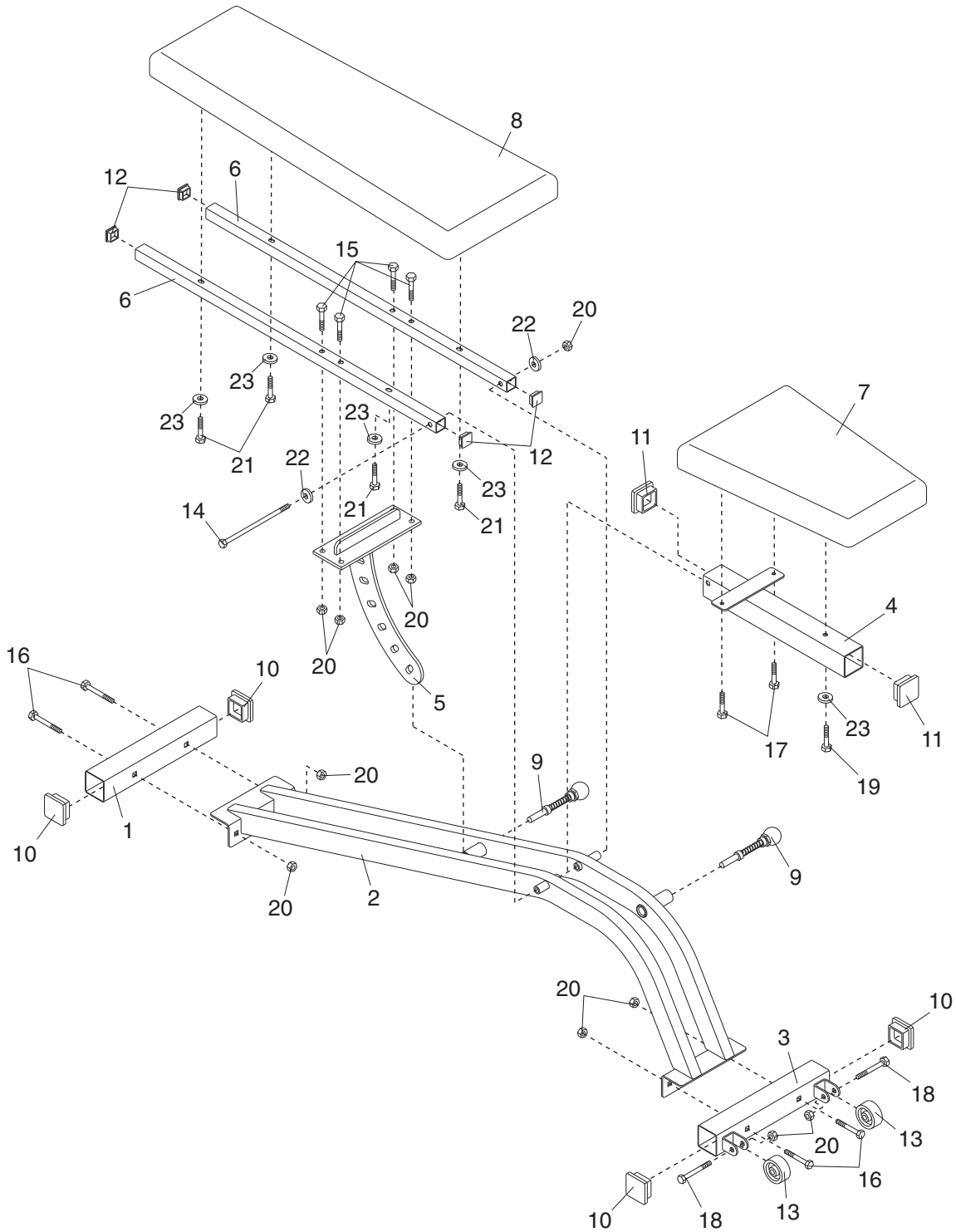

ORDERING REPLACEMENT PARTS

To order replacement parts, see the front cover of this manual. To help us assist you, please be prepared to give the following information when calling:

- The MODEL NUMBER of the product (HGBE8991.1)
- The NAME of the product (EXECUTIVE BY PROFORM weight bench)
- The SERIAL NUMBER of the product (see the front cover of this manual)
- The KEY NUMBER and DESCRIPTION of the desired part(s) (see the PART LIST and the EXPLODED DRAWING on pages 14 and 15 of this manual)

LIMITED WARRANTY

ICON Health & Fitness, Inc. (ICON), warrants this product to be free from defects in workmanship and material, under normal use and service conditions, for a period of ninety (90) days from the date of purchase. This warranty extends only to the original purchaser. ICON's obligation under this warranty is limited to replacing or repairing, at ICON's option, the product through one of its authorized service centers. All repairs for which warranty claims are made must be pre-authorized by ICON. If the product is shipped to a service center, freight charges to and from the service center will be the customer's responsibility. For in-home service, the customer will be responsible for a minimal trip charge. This warranty does not extend to any product or damage to a product caused by or attributable to freight damage, abuse, misuse, improper or abnormal usage or repairs not provided by an ICON authorized service center; products used for commercial or rental purposes; or products used as store display models. No other warranty beyond that specifically set forth above is authorized by ICON.

ICON is not responsible or liable for indirect, special or consequential damages arising out of or in connection with the use or performance of the product or damages with respect to any economic loss, loss of property, loss of revenues or profits, loss of enjoyment or use, costs of removal or installation or other consequential damages of whatsoever nature. Some states do not allow the exclusion or limitation of incidental or consequential damages. Accordingly, the above limitation may not apply to you.

The warranty extended hereunder is in lieu of any and all other warranties and any implied warranties of merchantability or fitness for a particular purpose is limited in its scope and duration to the terms set forth herein. Some states do not allow limitations on how long an implied warranty lasts. Accordingly, the above limitation may not apply to you.

This warranty gives you specific legal rights. You may also have other rights which vary from state to state.

ICON HEALTH & FITNESS, INC., 1500 S. 1000 W., LOGAN, UT 84321-9813